

User Guide to the Magellan Synthetic Aperture Radar Images

Stephen D. Wall

Shannon L. McConnell

Craig E. Leff

Richard S. Austin

Kathi K. Beratan

Mark J. Rokey



National Aeronautics and
Space Administration
Scientific and Technical
Information Branch

Jet Propulsion Laboratory
California Institute of Technology
Pasadena, California

NASA Reference Publication 1356
March 1995

*This publication was prepared at the Jet Propulsion Laboratory, California Institute of Technology,
under a contract with the National Aeronautics and Space Administration.*

Contents

1	Introduction	1
2	The Spacecraft	2
3	Mission Design	4
4	Experiment Description	15
5	Mission Operations	17
6	Notable Events and Problems	21
7	Data Product Description	37
8	Ordering Products	64

Appendixes

1	Acronyms and Abbreviations	65
2	References	66
3	Magellan Resources Document	67
4	SIS Reverse Reference List	101
5	MIDR Browse Images	136

Figures

2.1.	The Magellan Spacecraft	2
2.2.	Spacecraft Coordinate System	3
3.1.	Magellan Coverage (All Cycles)	5
3.2.	Planning Chart for Cycles 1 and 2	7
3.3.	Planning Chart for Cycles 2 and 3	11

3.4. Cursor for Use with Planning Charts	13
4.1. SAR Imaging Geometry	16
5.1. Uplink and Downlink Processes	18
7.1. Magellan Image Products	39

Tables

5.1. Upload Identifiers	19
5.2. Upload Number versus Orbit Number	19
6.1.A. Comments on Individual Swaths (Cycle 1)	24
6.1.B. Comments on Individual Swaths (Cycle 2)	28
6.1.C. Comments on Individual Swaths (Cycle 3)	30
6.2. DMS Gaps	35
6.3. Special Tests	36
7.1. Magellan SIS Documents	43
7.2. Begin and End Latitudes for BIDRs	46
7.3. BIDR File Structure	47
7.4. Engineering F-MIDR Label Identifications	47
7.5. CD-ROM File Structure	48
7.6. Cycle-1 Cn-MIDRs by Compact Disk	51
7.7. Cycle-1 F-MIDRs by Compact Disk	52
7.8. Cycle-2 Cn-MIDRs by Compact Disk	56
7.9. Cycle-2 F-MIDRs by Compact Disk	57
7.10. Cycle-3 Cn-MIDRs by Compact Disk	58
7.11. Cycle-3 F-MIDRs by Compact Disk	59
7.12. Magellan Data Product List	60

Introduction

*T*he Magellan mission acquired a data set impressive not only because it contains new data to be used by the scientific community for analysis of Venus, but also for its sheer size. As such, the newcomer is faced with the formidable task of understanding how the data set is structured before beginning any investigation of the information contained in the data set. As with most planetary missions, along with this acquisition of data have come a myriad of acronyms, procedures, programs, and documents, which contain some information useful to the researcher and much that, while it was necessary to the operation of Magellan, may be of little interest to the postmission researcher.

It has been the desire of the Magellan operations personnel to make the task of getting acquainted with this data set as painless as possible. The first and most time-consuming part of that task is being completed at this writing, as the archiving of the data themselves is accomplished. Yet we wish also to place in the hands of future analysts a summary of information which is not archived elsewhere (or difficult to obtain or interpret) to help him or her access the Magellan data archive.

This document is designed as a guide to the synthetic aperture radar (SAR), or imaging, data acquired by the Magellan Project during its mapping of Venus. Although the other experiments — altimetry, radiometry, and gravity — are mentioned, and their basic data records are described, the details of their data products are left for another volume. Within that limitation, the emphasis here is on subjects likely to be of interest to those who do not have firsthand experience with the Magellan mission. It is hoped that this document will provide them with enough information about the data set and its acquisition to allow best use of the data collected by the mission, without extensive reference to the Project's primary documentation. References are provided to more detailed information about how the Project was organized and run, but only minimal description is included.

This guide begins with brief descriptions of the Magellan spacecraft (Section 2) and the overall design of its mission (Section 3), including an overview of each mapping cycle's goals. Section 4 provides a summary of the experiments which were performed by the mission and their scientific objectives. Section 5 contains relevant information about how the mission was run. Section 6 describes events occur-

ring during the mission that may enhance or affect interpretation of the data. In Section 6, special tests of different acquisition modes, performed as precursors to subsequent cycle operations, are described with pointers to the data acquired, regardless of whether or not the modes were used in subsequent cycles. Spacecraft anomalies — including the well-publicized "walkabouts" — which had an effect on the data are also described in this section. Section 6 also includes a table of lower-level comments on each orbit's data. Section 7 provides information on the actual planetary coverage obtained and describes each product type. Some of the more highly processed products, such as the Stanford-produced Surface Characteristics Data Records and the U.S. Geological Survey's F-Maps, have not yet been completed and are only generally described here, but the basic SAR, altimetry, and radiometry products are treated in detail. Finally, Section 8 gives information on where data products may be ordered. For ease of use, acronyms and abbreviations are listed in Appendix 1; referenced documents are listed in Appendix 2.

For the most part, this guide is not an original work, but a compilation of summaries and excerpts from the various Project reports, both internal and in the public press, that in our opinion the analyst will need. As the ex-members of the Magellan Mission Operations Science Support Team and as the authors of this guide, we accept final responsibility for any errors or omissions, but we would like to express sincere appreciation to the many hundreds of individuals who made up the entire Magellan Team — they designed, coded, built, tested, programmed, and operated Magellan. In particular, it was the inspiration provided by Project Scientist Dr. R. Stephen Saunders that led to Magellan becoming a reality, and the leadership of Project Managers John Gerpheide, Anthony Spear, James Scott, and Douglas Griffith that made the mission a success. Joseph Boyce, David Okersen, Elizabeth Byers, Wesley Huntress, Lennard Fisk, and others at the National Aeronautics and Space Administration (NASA), which sponsored the Magellan mission, were ultimately responsible for providing resources and, often, much of the hard work as well. But the real utility of all this effort will not be measured by us but by future analysts, who will ultimately determine the value of the data. It is to those future analysts that this book is dedicated.

The Spacecraft

The Magellan spacecraft is shown in Figure 2.1. The high-gain antenna (HGA) was used both for communications with Earth and for transmitting radar signals to and receiving reflected radar signals from the surface of Venus. The low-gain omnidirectional command receipt antenna was used for emergency commanding. The altimeter antenna (ALTA), a long narrow structure fixed at a permanent angle to the HGA boresight, was used to determine the distance between the spacecraft and Venus' surface. The coordinate system used to refer to the spacecraft body is shown in Figure 2.2.

The forward equipment module (FEM) was approximately half occupied by the electronics for the radar and altimeter. The star scanner, an optical telescope with an electronic detector at the focal plane, looked out of the side of the FEM visible in the drawing. On the opposite side of the FEM from the star scanner was the medium-gain antenna (MGA), which was used for communications during cruise and was available for emergency downlink. The remainder of the components that resided in the FEM were the radio electronics, two batteries, the star scanner electronics, the gyroscopes and their associated attitude reference unit

electronics, and three momentum wheels for turning the spacecraft. At the base of the FEM, on either side, were the arms for the solar panels, with the articulation devices at each end. The two solar panels were deployed shortly after launch and remained deployed for the remainder of the mission.

Next to the FEM was the 10-sided structural bus, a spare from the Voyager program. The various bays of the bus contained the controls for the solar array drive motors, the two attitude control computers, the two command and data system computers, two tape recorders (generally referred to as Data Management Subsystems-A and -B [DMS-A and DMS-B]), four bulk utility memories, the power switching unit, and the power distribution unit. In the middle of the hollow bus ring was the hydrazine propellant tank. The engines and thrusters of the propulsion module were at the ends of the struts below the bus. Each of the four rocket engine modules contained two 440-N engines, a 22-N thruster, and three 0.9-N thrusters, which were used for midcourse trajectory corrections and orbit trim maneuvers (OTMs), and to desaturate the momentum wheels.

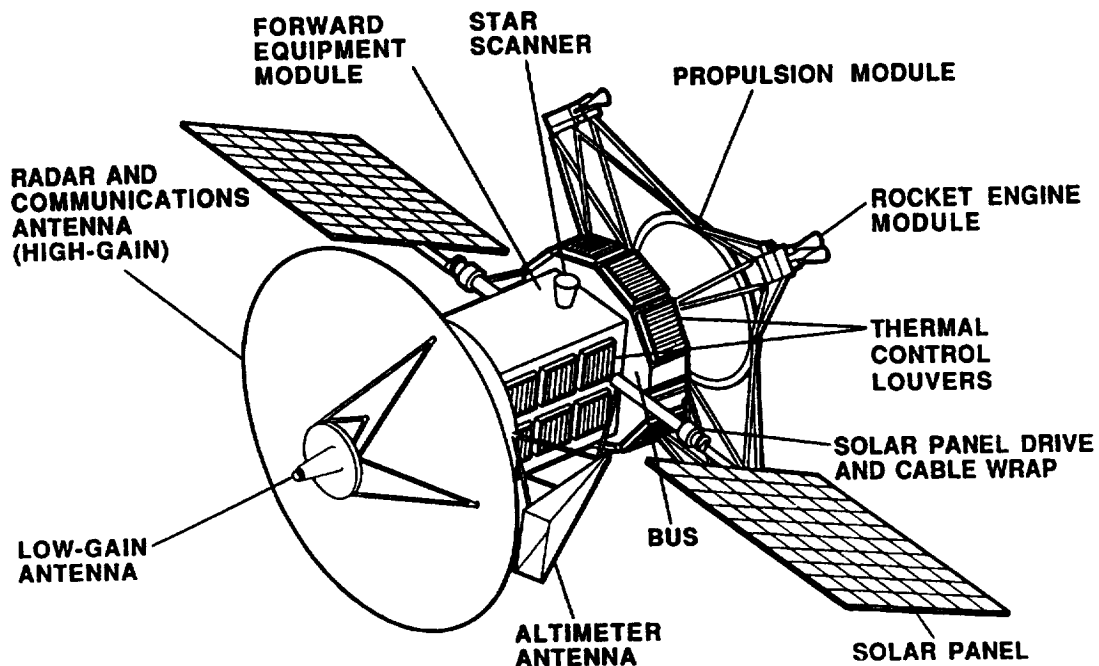

Figure 2.1. The Magellan Spacecraft.

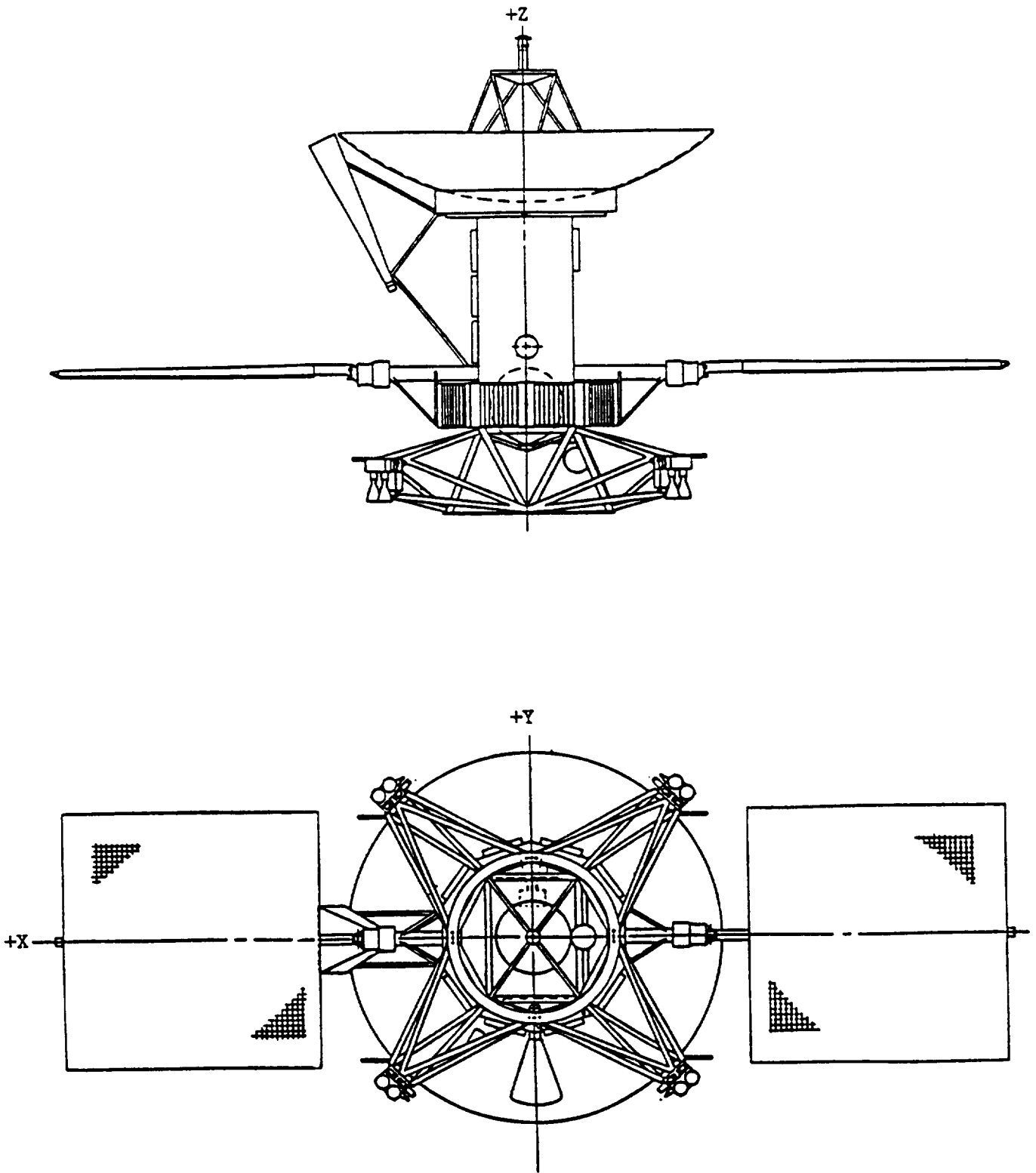

Figure 2.2. Spacecraft Coordinate System.

Mission Design

Much of the design effort for Magellan was dedicated to safely and accurately placing the spacecraft into its mapping orbit. Since this is now an accomplished fact, we will not discuss it here. The interested reader is referred to Wall, 1989, for an overview, and to Saunders et al., 1992, and other listed references for more detailed information.

After its cruise from Earth to Venus, the spacecraft was injected into an elliptical orbit around the planet using a burn of the main engine called Venus Orbit Insertion (VOI). The elliptical orbit was a design necessity largely for cost reasons (Wall, 1989); the less expensive solid-fuel main engine could only be ignited once, and a single-burn VOI can only produce an elliptical orbit.

ORBIT STRATEGY

Magellan's orbit was intentionally offset from polar so that the side-looking SAR could image Venus' north pole. Since the orbit plane was fixed in inertial space, the planet rotated under it once approximately every 243 Earth days. This period defined one Magellan mapping "cycle." As a result of the elliptical orbit, mapping of the surface was only possible on the side of the orbit containing periapsis, and during mapping swaths the distance from spacecraft to surface varied greatly. The portion of the orbit containing apoapsis was used to replay the recorded radar data to Earth, to perform star calibrations, and for other engineering purposes.

As the spacecraft approached the north pole, at about a 2200-km range, it turned its HGA toward the pole, pointing at a look angle of about 15° with respect to nadir and perpendicular to the direction of motion; then it began to take radar data, storing them on flight tape recorders at 806 kbits/s. As the spacecraft approached periapsis (about 290 km) it gradually rolled the HGA away from nadir to increase the imaging incidence angle, then pulled the HGA back toward nadir as the spacecraft neared the south pole. This slow change in angle with latitude is referred to as the "desired look-angle profile," or DLAP. For a more complete discussion of look angle, incidence angle, and other radar-imaging parameters, see Section 4.

Each mapping pass, or "swath," generated about 1.8 billion bits. At the conclusion of a mapping pass, the spacecraft turned the HGA to point to Earth. After a short period to allow the NASA Deep Space Network (DSN) antenna on the ground to acquire telemetry lock, the onboard tape re-

orders began to play back the recorded science data at 269 kbits/s. Near apoapsis, the playback was temporarily halted as the spacecraft updated its attitude knowledge by scanning a preselected pair of reference stars, and despun its momentum wheels if necessary; playback was then resumed. The spacecraft concluded playback in time to reorient itself over the Venusian north pole for the next mapping pass. Note that during the mapping pass the spacecraft was completely out of contact with Earth.

To maximize Venus data coverage in Cycle 1, Magellan alternated between imaging the north pole and imaging the southern latitudes. Orbits imaging the north pole begin at +90° and image Venus to about -55°. These orbits are called "immediate orbits" and are even-numbered. "Delayed orbits" image Venus from +55° to -89° and are odd-numbered. This rule applies throughout all mapping cycles. Coverage ranges for all orbits are listed in Section 7.

MISSION PHASES

Following VOI the mission proceeded in its nominal mapping phase for one cycle, obtaining images from about 78% of the planet. As described in Section 4, the SAR imaging principle requires images to be taken looking to one side of the spacecraft nadir track. Early in the planning phase it was decided to begin the mission "left looking" (i.e., with the radar antenna pointed to the spacecraft's left) and to cover the north pole first. The first cycle coverage, then, extended from +90° to about -78° latitude (with some variation in the southern limit required during thermally difficult periods). Cycle 1 succeeded in mapping most of the planet, interrupted only by the time periods listed in Section 6.

In Cycle 2 the SAR was used to look to either left or right side, so that the larger gaps in the Cycle-1 coverage could be filled while a view of the south polar area was obtained. Since right-looking coverage north of the Cycle-1 southern limit was redundant, mission planners decided to change that portion of the look-angle profile which involved the repeat coverage to be different than that of Cycle 1, to give a different perspective in the redundant data. Note also that during Cycle 2 several special tests were performed using other DLAPs and other look directions. These tests are described in Section 6.

Cycle-2 right-looking SAR data are not, however, an exact match for the Cycle-1 left-looking data, and Cycle 3 was used to cover some portions of the planet once again with

left-looking geometry, to search for changes in the surface. Additional data for stereo were also obtained. At the conclusion of Cycle 3 the spacecraft periapsis was lowered and radar-mapping operations terminated so that higher resolution gravity information could be collected by careful tracking of the spacecraft orbit for Cycle 4.

Total Magellan coverage, irrespective of cycle or look angle, exceeded 98% of the surface area of Venus. Combined coverage is shown in Figure 3.1.

ORBIT NUMBERING SCHEME

During the cruise period, several tests were organized to prepare both the spacecraft and ground teams for the mapping phase. These tests produced telemetry data (with no meaningful science data) which were labeled with orbit numbers beginning with 1. To avoid confusion with these test data, the first Magellan orbit around Venus is numbered 100. However, no archivable science data were produced until the completion of an in-orbit checkout period of 275 orbits. Mapping Cycle 1, therefore, begins with orbit number 376. Orbit numbers corresponding to other cycles are shown in Section 6.

PLANNING CHARTS

To the analyst, image data are usually associated with their location on the planet surface, in terms of latitude and longitude. However, to the mission planner, these data are more often associated with acquisition time (either absolute or relative to periapsis passage), spacecraft position, or other variables. In order to easily visualize the relationship between these two viewpoints, planning charts were devised by the Magellan operations teams. As an aid to the analyst these planning charts are reproduced in Figures 3.2 and 3.3. The SAR and altimeter ground tracks, which moved along these charts as a function of time, can be overlain by reproducing Figure 3.4 onto a transparency and using the appropriate section as a cursor on the planning charts, aligning the index mark with the acquisition date on the lower scale. In this way individual locations on the planet can be easily related to date of uplink, date of acquisition, upload number, and time since periapsis (TSP). Analysts can use Figure 3.4 as a guide to determine which orbits contain the desired data and to get a feel for the different DLAPs which were used to maximize the radar mapping.

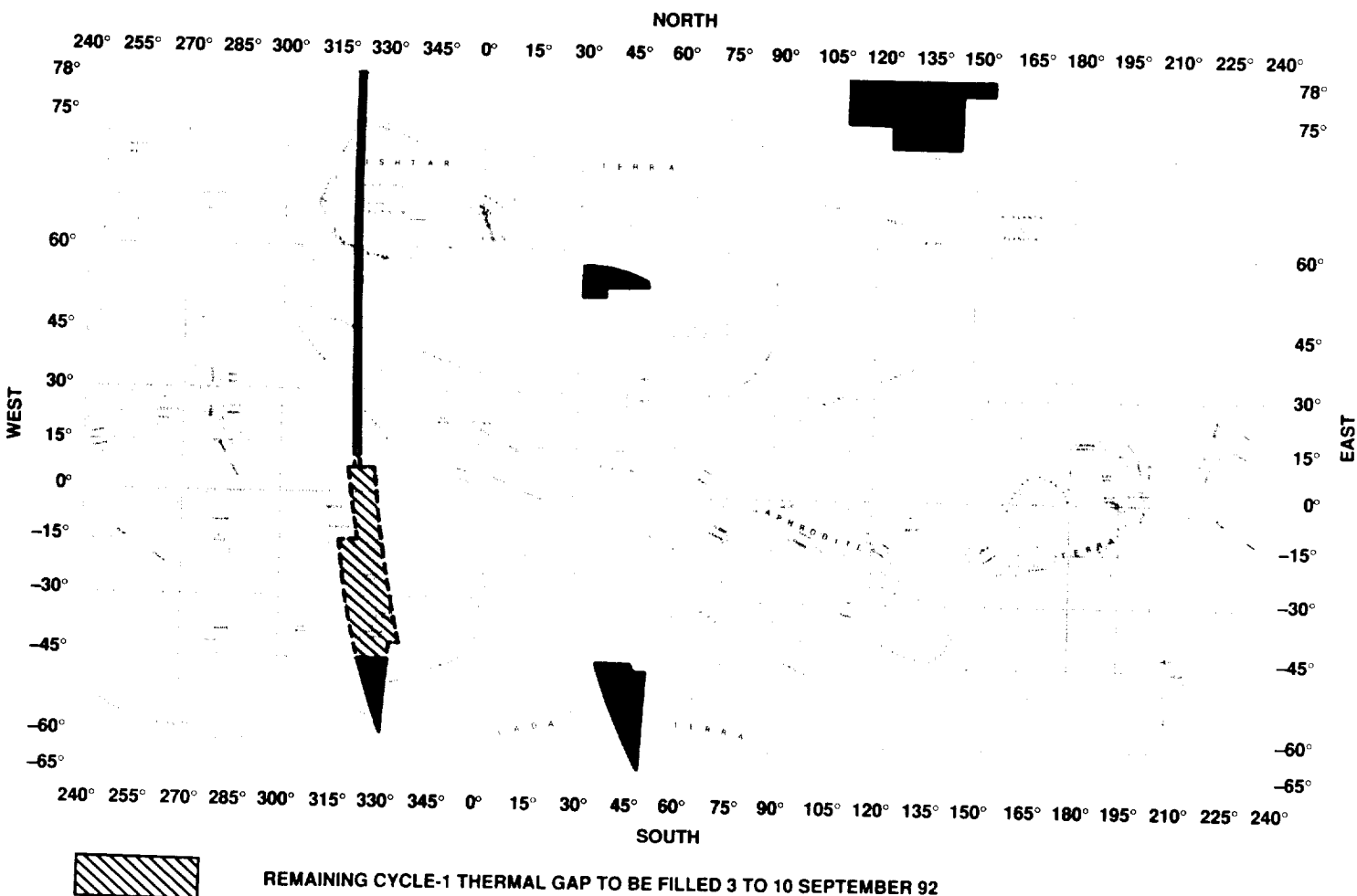

Figure 3.1. Magellan Coverage (All Cycles).

HOW TO USE THIS CHART

This planning chart was prepared for the purpose of tracking the mapping coverage of the Magellan Mission. Current or expected mapping coverage may be found by keying the overlay to the desired map scale, e.g., longitude or days past VOI. The current version of this map was updated from Revision A (dated May, 1990) with most of the changes being direct results of the delay in the start of mapping. This version assumes that mapping begins on September 15, 1990.

The overlay depicts both altimeter (nadir-looking) and SAR (left-looking) boresight tracks. The long vertical marks at the top and bottom of the overlay should be aligned with the desired date or other scale. The altimeter and SAR boresight tracks should then be in the correct position for that time in the mission.

Two important details should be noted:

- 1) The tick marks on the boresight tracks are placed at the equator and NOT at periapsis, 10°N. This was done to take advantage of the more detailed longitudinal information along the equator in the base map.

Periapsis information may be obtained by using the true anomaly scales running vertically on both sides of the chart. True anomaly is the angle formed by a line running from the center of the planet to the spacecraft with respect to periapsis.

Thus, for Magellan, when the spacecraft is at periapsis, its true anomaly is 0°, at the north pole, the true anomaly is -80° and at the south pole the true anomaly is +100°.

- 2) The boresight tracks are wider than an actual F-BIDR would be at this scale. The width of an F-BIDR at the equator is only 20-25 km, or about 0.2°. It is not possible to represent this width accurately on a map of 1:50M scale, and the user should not be misled into believing that the boresight track widths are accurate on the overlay.

This map is accurate to the extent possible given the resolution of the base map. Figures presented are correct as of the printing date. Errors or omissions should be brought to the attention of the preparer.

SEQUENCE INFORMATION

RADAR PARAMETER UPDATES

- 1) Uploads are on indicated dates.
- 2) Tweaks are on upload +3 days.
- 3) Last chance to change sequences is an upload -8 days.

LEGEND

AO	Apoapsis Occultation
C1, C2, C3	C1-, C2-, C3-MIDRs
DOY	Day of Year
F-BIDR	Full-Resolution Basic Image Data Record
SC	Superior Conjunction
VOI	Venus Orbit Insertion

Note: All dates refer to the nominal mapping mission (Cycle 1) unless otherwise noted.

Prepared by: Shannon McConnell & Craig Leff

Rev. B
November 1990

FOLDOUT FRAME

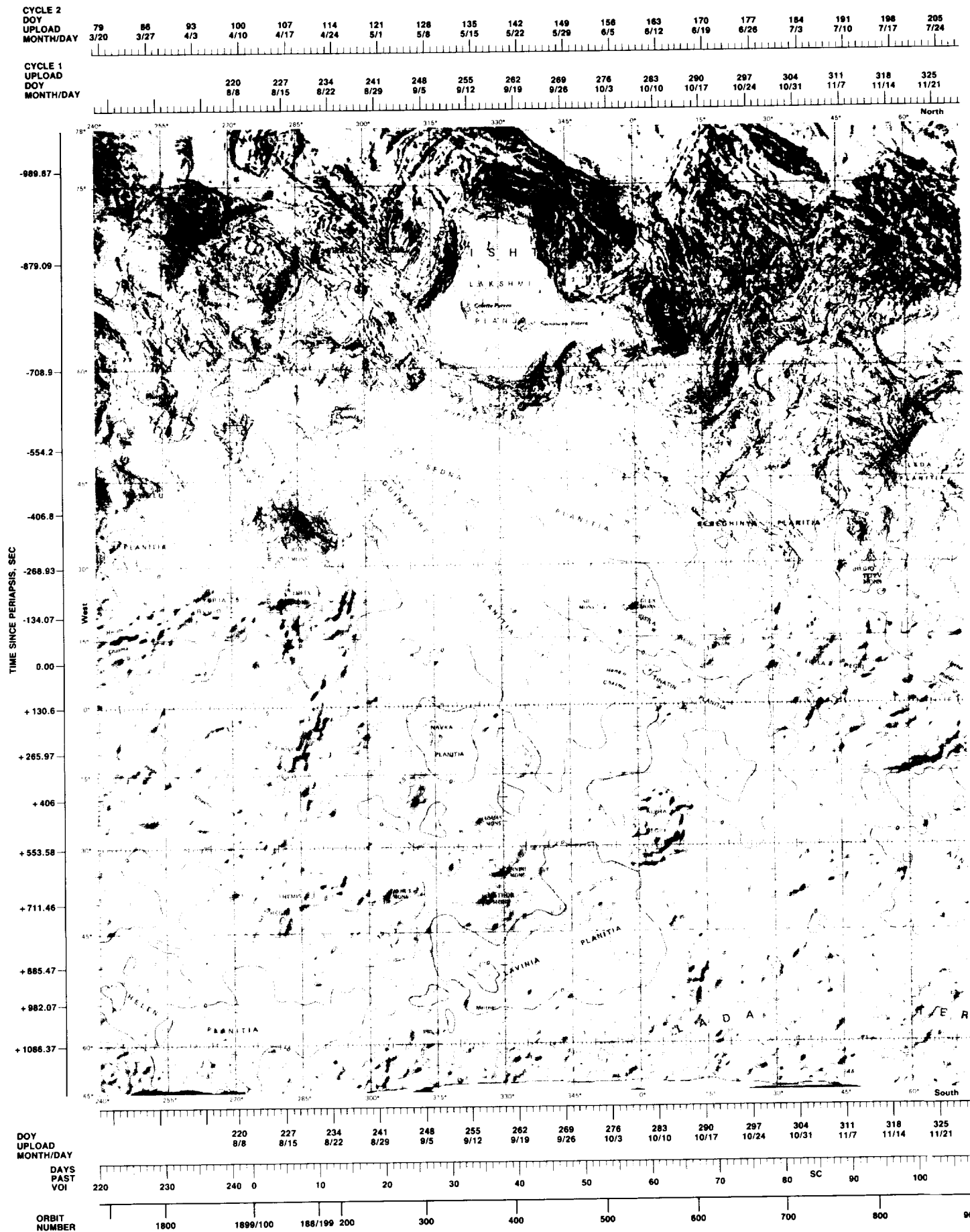

Figure 3.2. Planning Chart for Cycles 1 and 2.

HOW TO USE THIS CHART

This planning chart was prepared for the purpose of tracking the mapping coverage of the Magellan Mission. Current or expected mapping coverage may be found by keying the overlay to the desired map scale, e.g., longitude, days past VOI, or orbit number. The current version of this map was updated from Revision B (November, 1990) and is designed specifically to pertain to Cycle 3 of the Magellan Mission.

The overlay depicts both Altimeter and SAR boresight tracks for left-looking and right-looking mapping profiles. The long vertical marks at the top and bottom of the overlay should be aligned with the desired date or other scale. The corresponding altimeter and SAR boresight tracks should be in the correct position for that time in the mission.

The Cycle 3 DOY scale begins at VOI + one year, wraps around to the top scale, and then returns to the bottom scale, finishing up in the same place as it began. In addition, on the Orbit Number scale, orbit numbers are included for Cycle 3. Keep in mind that orbit numbers are linear and ascending beginning at VOI (orbit number 100).

Two important details should be noted:

- 1) The tick marks on the boresight tracks are placed at the equator and NOT at periapsis, 10°N. This was done to take advantage of the more detailed longitudinal information along the equator in the base map.

Periapsis information may be obtained by using the true anomaly scales running vertically on both sides of the chart. True anomaly is the angle formed by a line running from the center of the planet to the spacecraft with respect to periapsis.

Thus, for Magellan, when the spacecraft is at periapsis, its true anomaly is 0°, at the north pole, the true anomaly is -80° and at the south pole the true anomaly is +100°.

- 2) The boresight tracks are wider than an actual F-BIDR would be at this scale. The width of an F-BIDR at the equator is only 20-25 km, or about 0.2°. It is not possible to represent this width accurately on a map of 1:50M scale, and the user should not be misled into believing that the boresight track widths are accurate on the overlay.

This map is accurate to the extent possible given the resolution of the base map. Figures presented are correct as of the printing date. Errors or omissions should be brought to the attention of the preparer.

LEGEND

AO	Apoapsis Occultation
CY3	Cycle 3
DOY	Day of Year
F-BIDR	Full Resolution Basic Image Data Record
SC	Superior Conjunction
VOI	Venus Orbit Insertion 10 August, 1990

Prepared by: Shannon McConnell
Rev. C
December 1991

COLDOUT FRAME

2

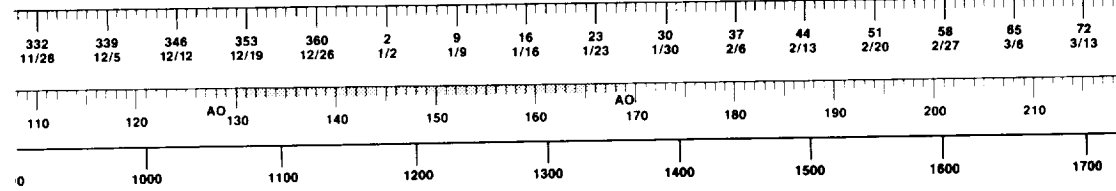
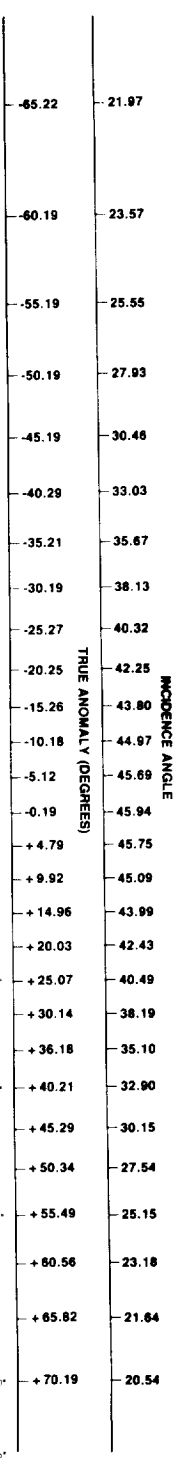
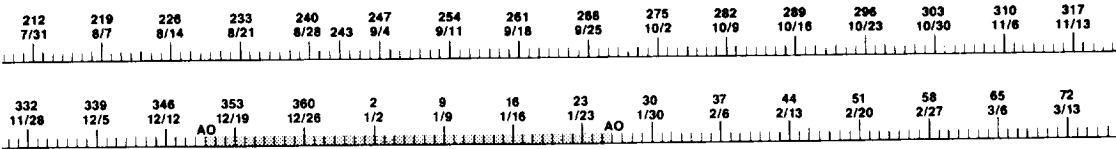



WELDOUT FRAME 1.

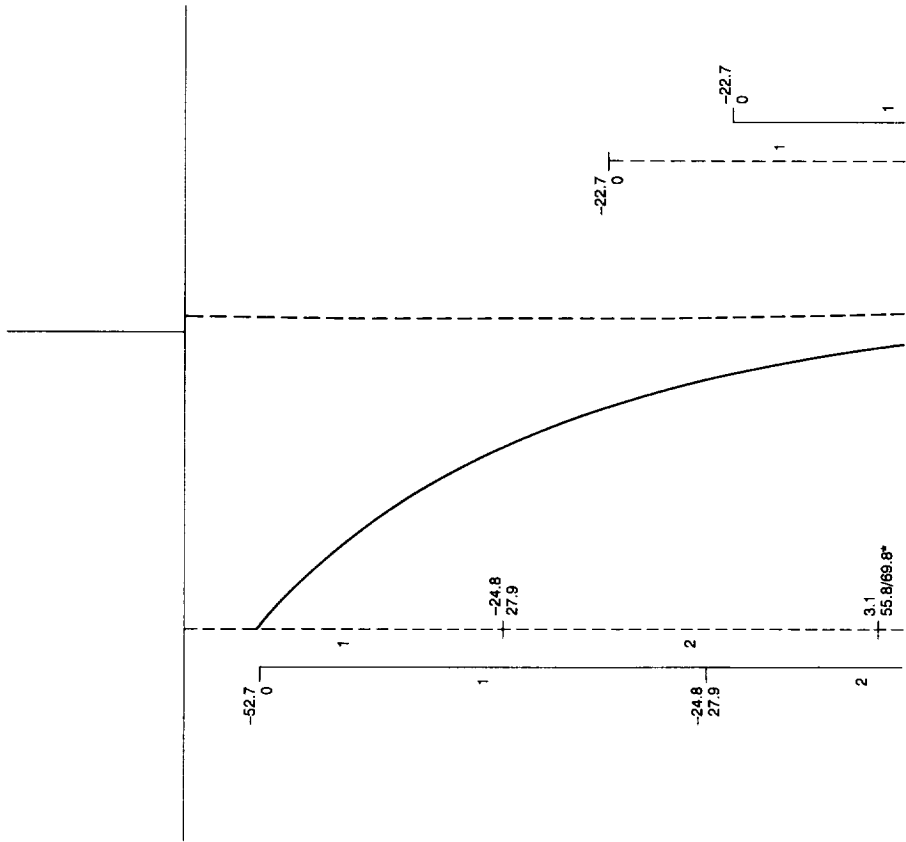
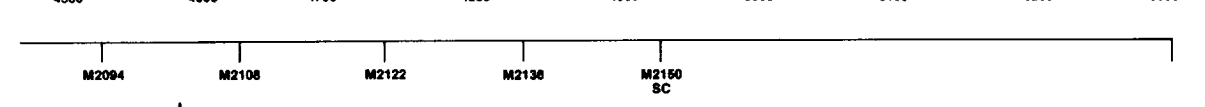
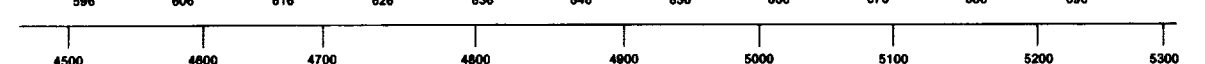
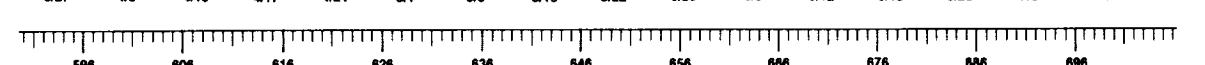
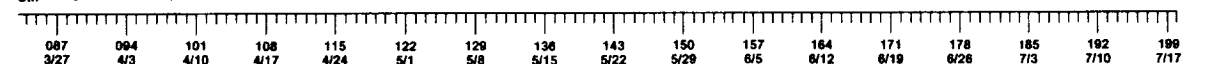
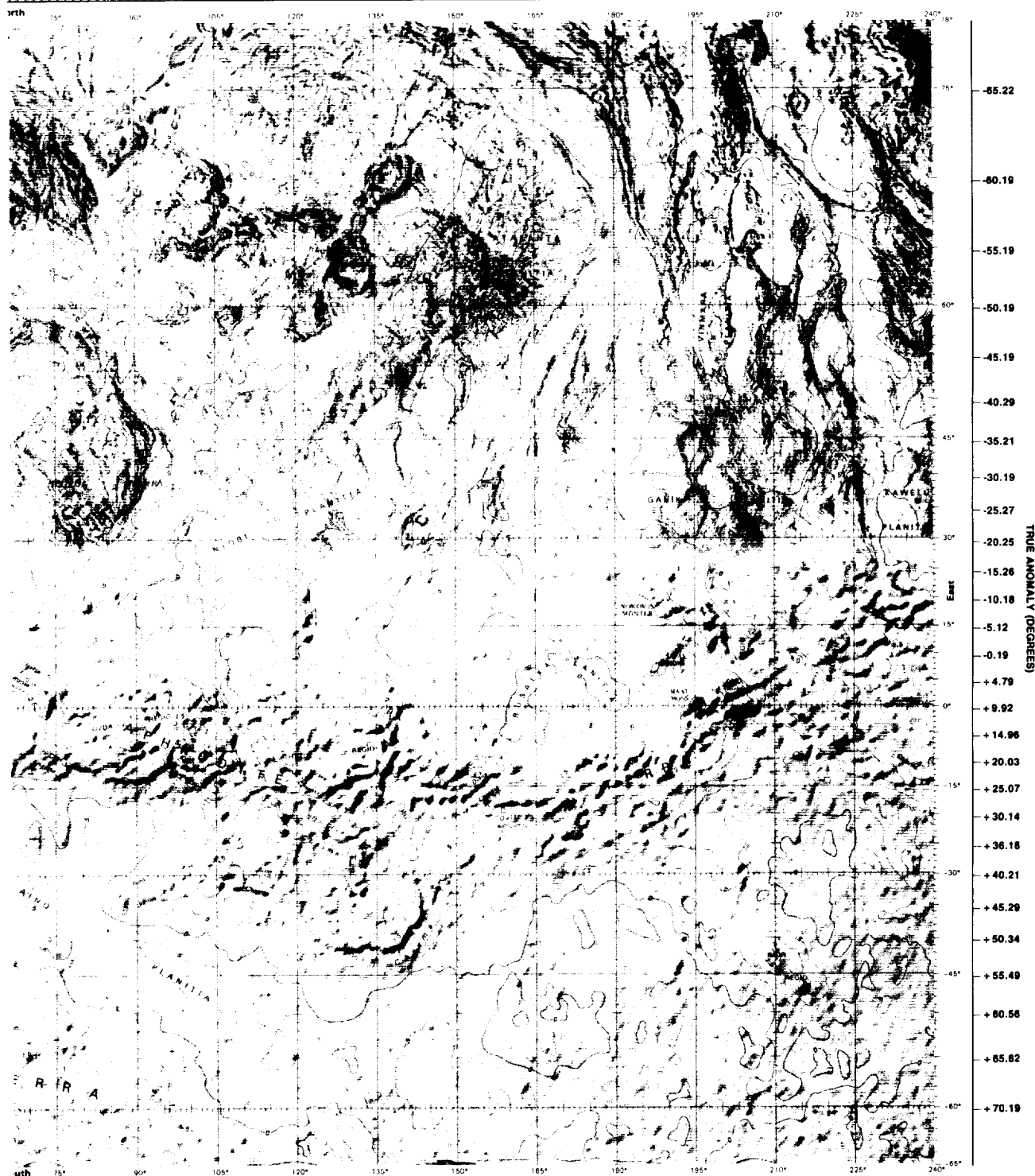
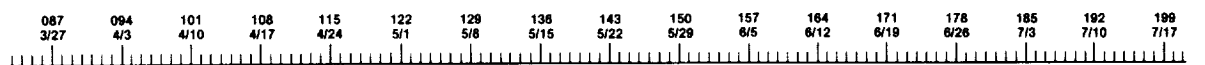
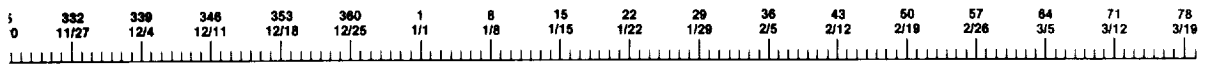

Figure 3.4. Cursor for Use with Planning Charts.

15 2



COLDOUT FRAME

2.

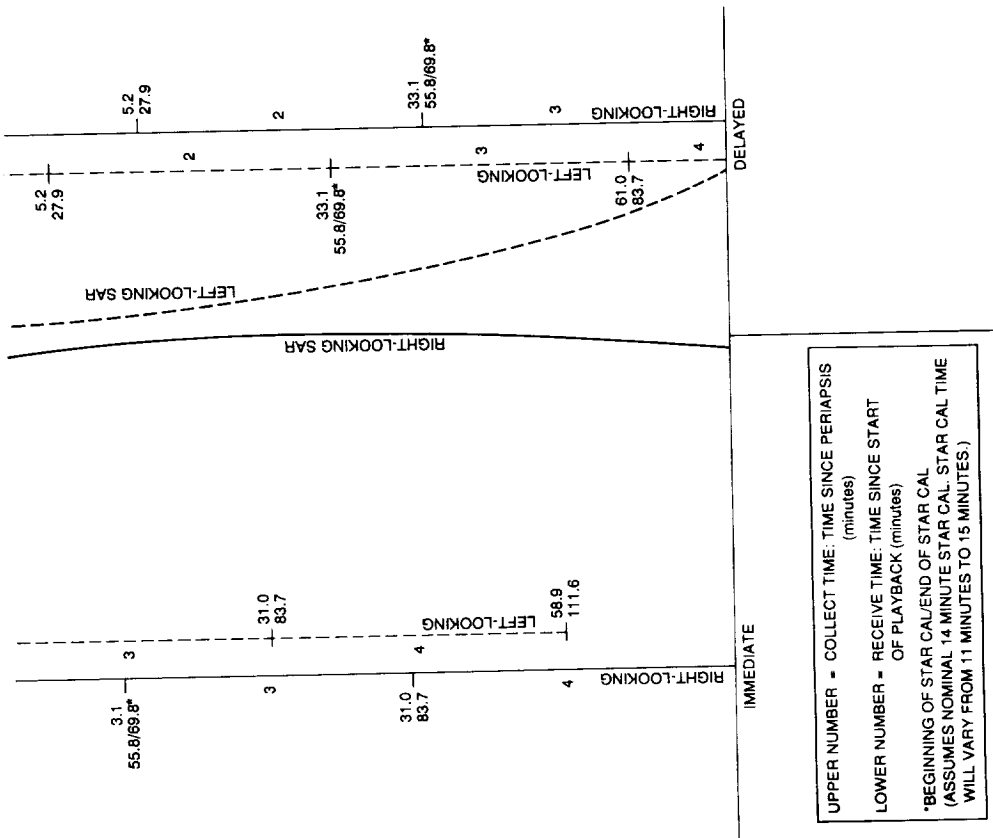

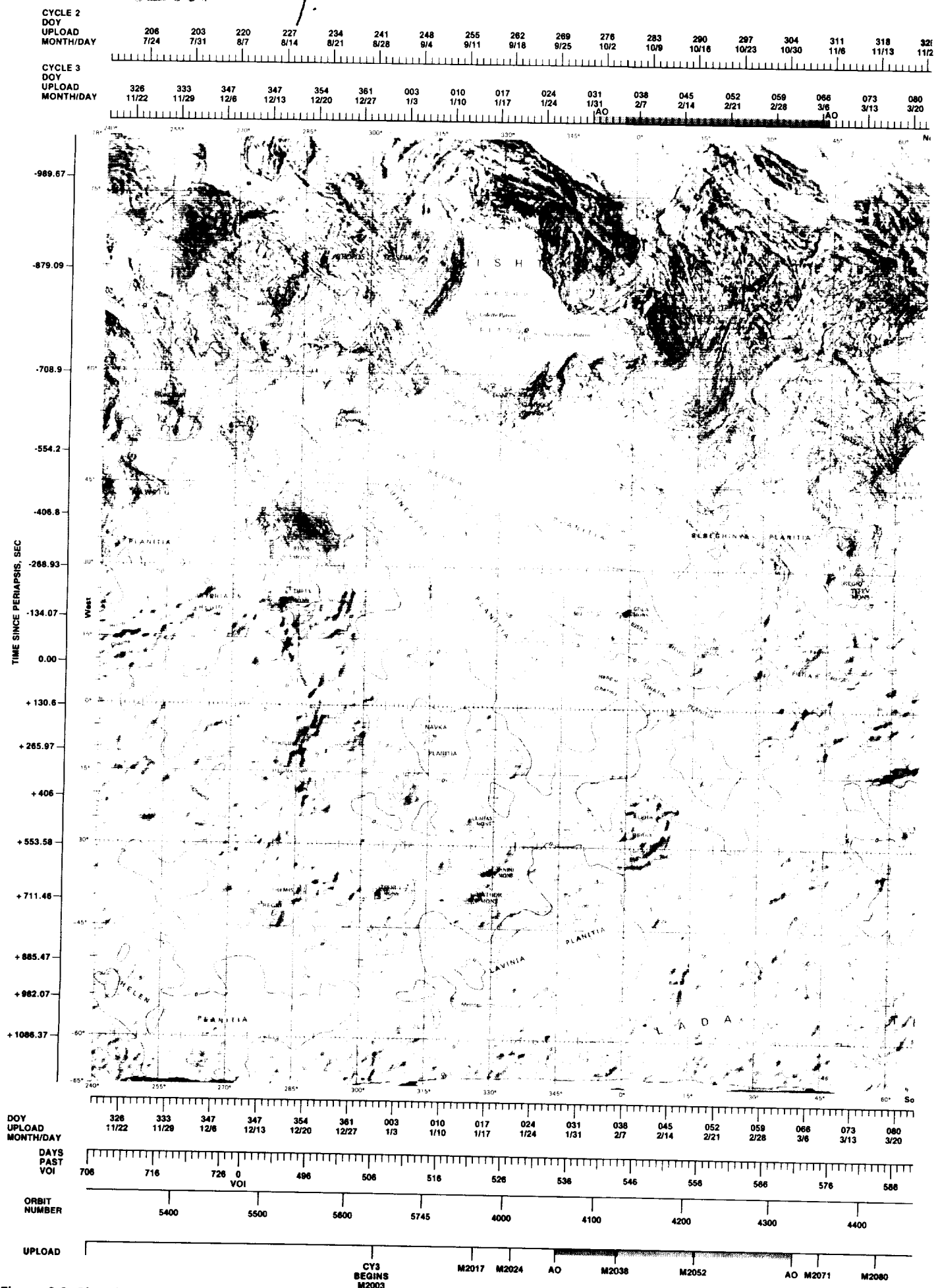

Figure 3.3. Planning Chart for Cycles 2 and 3.

Experiment Description

The Magellan spacecraft payload consisted of a single radar instrument which served three of its four experiments (Johnson, 1991). The instrument used a single microwave S-band (12-cm-wavelength) receiver and transmitter,¹ and the HGA. These elements acted in different ways to perform the different investigations. The SAR experiment mapped the HH (horizontally polarized transmit, horizontally polarized receive, where "horizontal" is with reference to the planet surface) S-band backscatter of the surface of Venus (e.g., Ulaby et al., 1982). An additional investigation, the gravity-mapping study, used the entire spacecraft and its radio telemetry system to measure small perturbations in the spacecraft orbit and thus infer details about the planetary gravity field. Analyses of Magellan data by the Magellan science teams are reported by Saunders et al., 1991, and Saunders et al., 1992; see also other articles in the same volumes. Pre-Magellan knowledge of Venus is summarized by Hunten et al., 1983.

During mapping, the radar sent out a series of "bursts," each consisting of a series of pulses, at a rate called the pulse repetition frequency (PRF). The first pulses were sent out through the HGA, directed to one side of nadir by an amount referred to as the look angle² (see Figure 4.1). The value of the look angle and the spacecraft location also determined the SAR incidence angle — the angle between local vertical (assuming a spherical surface) and the spacecraft as seen from the surface. Between pulses, the radar receiver, also attached to the HGA, listened for previously emitted pulses, or "echoes," returned from the Venusian surface. By a technique called SAR correlation, these echoes were then transformed into images (Curlander et al., 1991). A natural trade-off exists between low look-angle imaging geometry, which returns stronger echoes and thus less-noisy images, and higher look angles, in which the perspective generally allows better image interpretation. Magellan's choice was to always use the greatest possible look angle consistent with a

minimum signal-to-noise ratio in the returned signal. Given the spacecraft's elliptical orbit, this choice had the look angle varying from about 17° at the north pole to about 45° near periapsis (+10° latitude) and back to lower angles in the southern latitudes. In Magellan documentation this variation in look angle with latitude is frequently referred to as the DLAP (see Section 3).

Because of this variation in range, the number of "looks" (defined as independent observations of the surface element) and resolution of the Magellan SAR images also varied as a function of latitude on the surface of Venus and of the DLAP used while imaging. The predicted resolution cell size for specific orbits can be found in the Experimenters' Notebook, an archive of Magellan orbital data (for general contact information, see Appendix 3). For a discussion of "looks" in SAR images, see Elachi, 1988, page 80.

At the end of the SAR burst another antenna was selected which emitted a fan-shaped beam directed to nadir. This antenna is often referred to as the altimeter antenna (ALTA). More pulses were then sent and returned, but this time the objective was to record the time of flight of the pulses so that the distance to the planet could be determined. The amplitude of the returned echoes was also recorded to infer the low-angle scattering properties of the surface. Finally, a brief time period was reserved for the receiver alone to record the natural Venusian microwave emissions, allowing determination of the surface brightness temperature.

Magellan's original goal was to systematically map Venus. It was hoped that in the first cycle of mapping it would be possible to cover over 70% of the surface. This goal defined Magellan's primary mission. The strategy devised to accomplish this goal had Magellan begin radar bursts over the north pole on even-numbered orbits and continue until the spacecraft's tape recorders were filled with data; on odd orbits the start of this imaging "swath" was delayed and thus extended further south. In this way the swaths neatly covered the surface at both northern and southern extremes. The even swaths were labeled "immediate" swaths, and the odd swaths "delayed."

¹ The radar's receiver, transmitter, and other essential elements were actually redundant, but only one of each was employed at a time.

² The orientation of the plane in which the look angle was measured is referred to as either the look azimuth angle or the look direction angle. This angle also was varied with latitude.

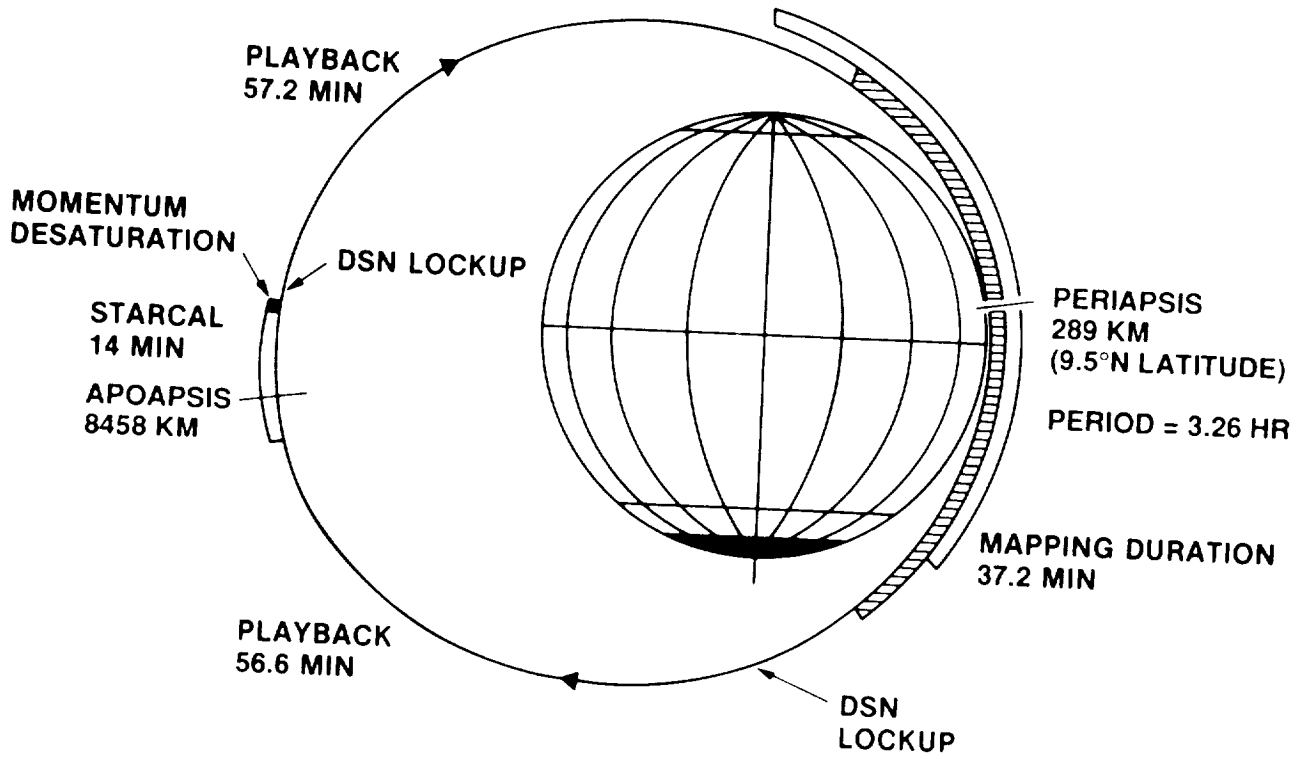

Figure 4.1. SAR Imaging Geometry.

Mission Operations

The Magellan mission was operated in two functional divisions or processes, called uplink and downlink. Although these were by no means independent, it is convenient to describe them separately. More complete description of Magellan operations can be found in Chapter 7 of Wall et al., 1992.

THE UPLINK PROCESS

Magellan's uplink process satisfied mission objectives by developing and uploading sequences of platform and payload activities that responded to requests for user or engineering data, interspersed with supporting ground events. The process was divided into a number of tasks which defined the sequence design steps. These were advanced sequence planning, sequence planning, sequence generation, and command processing. In advance sequence planning, a time-ordered list of activities was developed based on a mission plan, which was composed of requirements and constraints at a high level. A sequence was then formed which flowed from task to task where the sequence was repetitively refined. In the command-processing task, a command file of intended activities was radiated to the spacecraft.

Figure 5.1 shows how the uplink and downlink processes worked together. The Mission Plan was periodically updated, generally once per mission phase. Thus, a Mission Plan was written for cruise, updated for the first cycle, updated again for the second cycle, and so on. Each version of the Mission Plan was used to generate advanced sequence planning. An advanced sequence plan was combined with ground events such as ground antenna coverage requirements and sent to the first phase of sequence planning. In sequence planning, the preliminary sequence of commands was produced. Some iteration was commonly required between the sequence designers and the sequence builders as a thorough review of the preliminary sequence was conducted and the details in the sequence were filled in. After such iteration a final sequence design was produced, along with two levels of printed schedules. The final sequence was transformed into a command file and, together with the schedules, was transferred to the DSN. Each upload file was assigned a number, constructed as shown in Table 5.1. This number identifies the date of the upload event, the upload type, and the cycle number. A list of which orbits were executed in which sequence is contained in Table 5.2. This table was compiled chronologically and is divided into Cycle 1, Cycle 2, and Cycle 3.

Even though Magellan was not, by nature, adaptive to science discoveries, science data analysis results were considered on a long-term basis. Engineering data analysis results were also considered at all levels of sequence design, since non-nominal conditions on the spacecraft affected subsequent commanding. Anomalies resulting in data gaps were logged so that in the following cycles, the sequences could be modified to recover the lost data. All of these factors affected sequence planning during the mission.

As the upload was completed, a brief description of the goals, problems, and other items of interest was compiled and entered into the Experimenters' Notebook. These comments can be accessed either by use of the Magellan Hypermap, described in Section 7, or by referring to Section 6.

THE DOWNLINK PROCESS

Magellan's downlink process began with production of the radar data and spacecraft engineering data on board. During mapping, radar data were recorded onto the DMS-A and -B tape recorders at 806 kbits/s. Each DMS had four tracks. Odd- and even-numbered tracks were generally played in opposite directions to minimize motion of the tape. Since time was required to switch from, for example, track-1 forward motion to track-2 reverse motion, the nominal data-recording strategy involved alternating tracks from DMS-A to DMS-B to avoid loss of data during the track-switching time. For example, data might be recorded on DMS-A track 1 in the forward direction, followed by DMS-B track 1 forward, followed by DMS-A track 2 reverse, etc. Playback of the data was accomplished in the same sequence, but at 269 kbits/s. Note, however, that due to a failure in DMS-A during Cycle 1 this strategy was modified for much of the mission as described in Section 6.

The playback rate from the DMS units was higher than the capability of the DSN to transmit data from its station complexes to the network control center at the Jet Propulsion Laboratory (JPL). Therefore, most of Magellan's science data were transferred to JPL on computer tapes called original data records (ODRs) which were shipped from the individual DSN complexes. In order to verify that the sensor was healthy and properly commanded, a small percentage was

selected at the individual stations and transferred by electronic means at a lower rate. This created two situations which complicated the mission operation. First, a significant percentage of the radar data was handled twice — once for health analysis and again to process the science data. Second, much of the mapping data arrival was delayed by up to several weeks. As tapes arrived from the DSN complexes (in California, Spain, and Australia), the data were received in an unpredictable order and had to be staged until mosaics could be assembled in the order in which the individual mapping strips were taken.

Independent of the science high-rate operation was a lower rate telemetry channel, at 1.2 kbits/s, of engineering telemetry and ground-processing monitor data which were transferred to the operations center in real time to monitor the health of all spacecraft subsystems, especially those critical to current operations. These data were decommutated,

decalibrated, and alarm limit checked as they were displayed on screens in front of spacecraft controllers who monitored the health of the spacecraft and its instrumentation 24 hours per day.

ODRs received at the operations center at JPL were processed by the ground data system into images and other data products. The ODRs were first read into the Magellan High-Rate Processor (MHR), which synchronized the data stream into frames and removed periods during which two DSN stations were simultaneously receiving data. Engineering data were removed from the data stream for use by spacecraft teams, and ancillary data (such as spacecraft ephemerides produced from tracking data) were added, producing three different types of tapes called the experiment data records (EDRs). Image data, contained on the SAR-EDRs, were read into the SAR Data-Processing Subsystem (SDPS), which produced individual image strips called full-resolution basic image data records (F-BIDRs). Section 7 describes the data products created from these tapes.

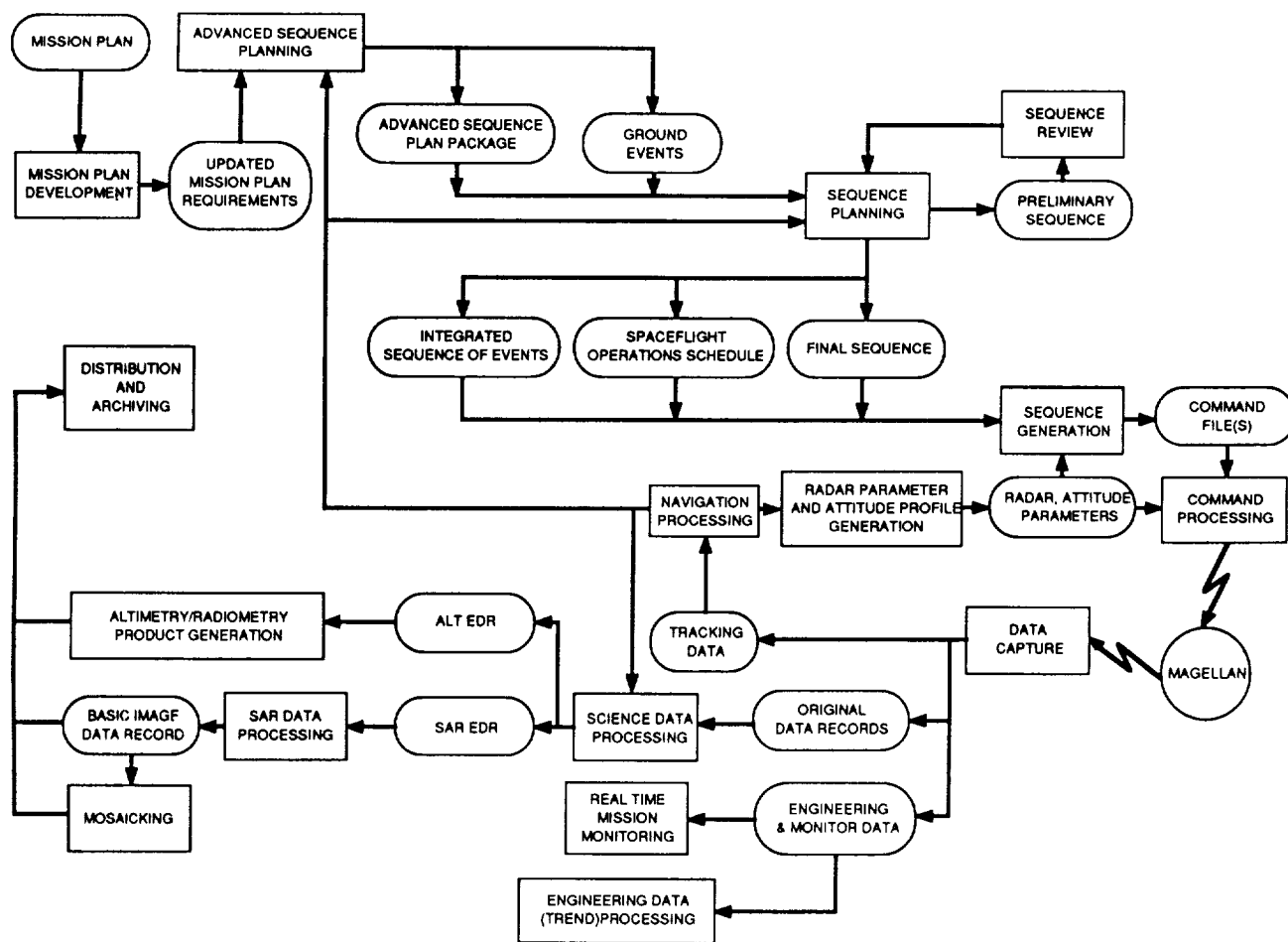

Figure 5.1. Uplink and Downlink Processes.

Table 5.1. Upload Identifiers.

General format: *Tnnnn*

where

T = one of the following:

M, which identifies a normal mapping upload

P, *D*, or *Q*, which identifies a sequence modifying an onboard mapping sequence

nnnn = 4-digit number in which the first character indicates the cycle number as follows:

0 = Cycle 1

1 = Cycle 2

2 = Cycle 3

The last three characters represent the calendar day of the year on which the sequence was uploaded. For example: M0268 was a mapping upload for Cycle 1 which was uploaded on day 268 (September 25) of the year.

Table 5.2. Upload Number versus Orbit Number.

CYCLE 1		CYCLE 2		CYCLE 3	
UPLOAD	ORBITS	UPLOAD	ORBITS	UPLOAD	ORBITS
M0258	376-403	M1138	2176-2218	M2024	4031-4057
M0262	404-424	M1143	2219-2234	D2028	4058-4079
M0265	425-446	M1145	2235-2269	D2031	4080-4108
M0268	447-455	M1150	2270-2293	D2035	4109-4131
M0269	456-476	M1154	2294-2313	M2038	4132-4160
M0272	477-506	M1156	2314-2337	D2042	4161-4182
M0276	507-527	M1160	2338-2365	D2045	4183-4211
M0279	528-558	M1163	2366-2389	D2049	4212-4234
M0283	559-579	M1167	2390-2416	M2052	4235-4263
M0286	580-609	M1170	2417-2440	D2056	4264-4285
M0290	610-630	M1174	2441-2464	D2059	4286-4314
M0293	631-661	M1177	2465-2488	D2063	4315-4336
M0297	662-682	M1180	2489-2519	D2066	4337-4367
M0300	683-698	M1184	2520-2543	M2070	4368-4388
M0311	765-785	M1188	2544-2581	D2073	4389-4417
M0314	787-816	M1193B	2582-2586	D2077	4418-4440
M0318	817-837	M1193E	2587-2612	M2080	4441-4455
M0321	838-867	M1197	2613-2642	D2082	4456-4458
M0325	868-888	M1201	2643-2673	D2083	4459-4491
M0328	889-919	M1205	2674-2681	D2087	4492-4520
M0332	920-940	M1206	2682-2688	D2091	4521-4543
M0335	941-970	M1207	2689-2716	M2094	4544-4566
M0339	971-991	M1211	2717-2740	D2097	4567-4574
M0342	992-1022	M1214	2741-2768	D2098	4575-4594

Table 5.2. Upload Number versus Orbit Number (Cont.).

CYCLE 1		CYCLE 2		CYCLE 3	
UPLOAD	ORBITS	UPLOAD	ORBITS	UPLOAD	ORBITS
M0346	1023-1045	M1218	2769-2791	D2101	4595-4623
M0349	1046-1073	M1221	2792-2819	D2105	4624-4646
M0353	1074-1097	M1225	2820-2843	M2108	4647-4675
M0356	1098-1117	M1228	2844-2871	D2112	4676-4684
M0359	1118-1147	M1232	2872-2894	Q2113	4685-4697
M0363	1148-1168	M1235	2895-2922	D2115	4698-4726
M1001	1169-1199	M1239	2923-2936	D2119	4727-4749
M1005	1200-1227	M1241	2937-2974	M2122	4750-4778
M1009	1228-1250	M1246	2975-2998	D2126	4779-4800
M1012	1250-1278	M1249	2999-3025	D2129	4801-4829
M1016	1279-1301	M1253	3026-3049	D2133	4830-4852
M1019	1302-1330	M1256	3050-3077	M2136	4853-4881
M1023	1331-1354	M1260	3078-3101	D2140	4882-4903
M1026	1355-1382	M1263	3102-3128	D2143	4904-4918
M1030	1383-1403	M1267	3129-3152	D2145	4919-4921
M1033	1404-1434	M1270	3153-3180	D2146	4922-4955
M1037	1435-1455	M1274	3181-3204	D2150	4956-4985
M1040	1456-1477	M1277	3205-3231	M2178	5164-5190
M1043	1478-1485	M1281	3232-3255	D2182	5191-5205
M1044	1486-1507	M1284	3256-3283	D2184	5206-5242
M1047	1508-1537	M1288	3284-3307	D2189	5243-5265
M1051	1538-1558	M1289C	3291-3298	M2192	5266-5293
M1054	1559-1588	M1291	3308-3335	D2196	5294-5315
M1058	1589-1610	R1295	3336-3358	M2234	5574-5669
M1061	1611-1640	M1298	3359-3386	M2247	5670-5694
M1065	1641-1661	R1302	3387-3409	M2250	5692-5713
M1068	1662-1692	D1305	3410-3438	M2253	5714-5728
M1072	1693-1713	D1309	3439-3461	M2255	5729-5747
M1075	1714-1743	M1312	3462-3490		
M1079	1744-1764	R1316	3491-3513		
M1082	1765-1795	D1319	3514-3541		
M1086	1796-1816	D1323	3542-3564		
M1089	1817-1846	M1326	3565-3593		
M1093	1847-1868	M1330	3594-3616		
M1096	1869-1898	M1333	3617-3644		
M1100	1899-1919	D1337	3644-3667		
M1103	1920-1949	M1340	3668-3696		
M1107	1950-1970	M1344	3697-3715		
M1110	1971-2001	M1347B	3716-3719		
M1114	2002-2022	M1347D	3720-3747		
M1117	2023-2054	M1351	3748-3770		
M1121	2055-2078	M1354	3771-3807		
M1124	2079-2106	M1359	3808-3828		
M1128	2107-2130	M1362	3829-3858		
M1131	2131-2158	M2001	3859-3881		
M1135	2159-2175	M2004	3882-3902		
		M2007	3903-3924		
		M2014	3925-3976		

Notable Events and Problems

*I*n the early planning stages Magellan was seen as a highly repetitive mission that would not require performance of unique sequences. In retrospect, much of the mission proceeded that way. There were, however, a number of special occurrences that required special attention and deviation from the nominal plan described in Section 3. These occurrences fell into three categories: spacecraft- or command-related problems which had to be accommodated, planetary geometries which created thermal or other environmental conditions from which the spacecraft required protection, and special tests done by the Project to evaluate new data collection techniques for possible use later in the mission. In this section we describe all such events that had a significant effect on the science data and provide specific references to times of collection and effect on collection.

Tables 6.1.A through 6.1.C contain a summary of orbits which had problems, unexpected data outages, special tests, or milestones achieved. The notes in these tables are selected from more complete observations contained in the Experimenters' Notebook. The orbits are segregated by cycle and are listed chronologically.

SPACECRAFT-RELATED EVENTS

Fault Protection Events

Magellan experienced loss of computer control (termed "walkabouts") three times during its mapping mission, which resulted in a preprogrammed "safing" maneuver. Briefly, this maneuver was executed whenever the central computer (the Command and Data Subsystem, or CDS) failed to exchange a periodic signal from another computer charged with maintaining attitude control. The spacecraft then assumed that a fault had occurred and began sweeping the HGA in a cone centered in the direction of the Sun with a central angle equal to the current angular distance from Sun to Earth. After several hours in this maneuver, a second level of safing pointed the HGA directly at the Sun and held it there. These events were eventually traced to a timing problem in the attitude control system, which was fixed.

Tape Recorder DMS-A Failure and Subsequent Mapping Strategies

Two months into Magellan's mapping mission (Cycle 1), beginning with the image swath taken in orbit 650, a small patch of noisy data (in which features are difficult or impossible to see) appeared. This patch extended over approximately 0.3° in latitude at -16° latitude for immediate swaths and at -58° latitude for delayed swaths. As mapping continued, the length of this patch grew. By orbit 800, a small data gap (in which there is no image present in the swath) began to appear within these bad data. The length and frequency of these data gaps grew until, by orbit 1003, approximately one-third of each mapping orbit was lost.

The cause of the problem was traced to DMS-A, one of the two onboard tape recorders used for collecting mapping data during each orbit. The playback bit stream from DMS-A was sometimes a corrupted form of the stream recorded. The corruption took the form of an inverted bit followed by a missing bit. Thus, the bit pattern 1001 was sometimes played back as 111. Records containing corrupted data were not properly synchronized by the Magellan ground data system, and the result on the EDR tapes (see Section 5) was either corrupted records or, in some cases, missing records. The effect on image data after subsequent processing by the SDPS can be seen as some combination of loss of resolution, increase in noise, and data gaps. Later in the mission an improvement was made in the ground data system software (specifically, to the MHR) which enabled mildly corrupted data to be reconstructed (Scott et al., 1993). The affected EDRs were later recreated from the ODR data and reprocessed into new F-BIDRs. Some mosaicked image data records (MIDRs) were remade from the new F-BIDR data.

After the DMS-A problem was discovered, mission planners developed a substitute scheme called the single-DMS strategy whereby a full orbit could be mapped and recorded on DMS-B. The new scheme allowed the data to be recorded

on one track of DMS-B until it reached the end. Then the tape recorder stopped momentarily in order to align the next track on the tape before data were recorded on this next track. A full orbit could then fit onto one tape by using all of the available tracks. However, a small data gap (up to 0.5° in latitude) occurred each time a track switch was performed. Although switching to one tape recorder did not affect the length of the SAR swaths, it did cause a series of small gaps to appear in each swath since, after filling a track, the tape recorder stopped and realigned itself to record in the opposite direction. The resulting gaps extend approximately 0.3° in latitude. Table 6.2 lists the latitudinal extent of the DMS gaps.

Beginning with orbit 1098, this alternate mapping scheme was implemented with success. Zero to three of these small data gaps (called "DMS gaps" throughout this guide) are present in each orbit following 1098. In order to minimize the effect of these DMS gaps on science data, the gaps were at first shifted in latitude between uploads. Beginning with upload M1026 (orbit 1355), however, DMS gaps were not switched between uploads. Immediate and delayed orbits, of course, may still have different latitude ranges.

It should be noted that not all gaps listed actually appear in the image data. Due to record time, the number of looks varied with latitude. The Magellan science requirement was a minimum of four looks. Any area imaged in less than four looks was considered a gap. Therefore, if the number of looks failed to drop below four during any of these track switches, no visible gap occurred in the data.

The Extra DMS Gap

In uploads M1012 and M1019 (orbits 1252 through 1354) a different strategy was employed whereby the tape recorder was "slewed" prior to the playback of data. To slew the tape recorder meant to position the tape to the location desired. This strategy made it difficult for the DSN stations to acquire the high-rate data signal. As a result, these orbits contain an extra gap approximately 1° in length. The problem was rectified beginning with orbit 1355 (upload M1026) and did not recur.

Early Turn from Mapping

An onboard thermal emergency was the cause of a southern hemisphere data loss for uploads M1044 and M1058. Prior to these uploads, thermal sensors on the instrument panels were recording excessive temperatures. A quick change in the upload sequence caused the spacecraft to turn away

from mapping prior to the time of maximum heating. The tape recorder and SAR were left running. As a result, for swaths associated with these orbits the data became blurred and then faded to black as the spacecraft rotated for cooling below -52° latitude.

Thermal Hide Strategies

A thermal problem arose at the end of Cycle 1 in which the instruments were exceeding their safe heat limits. In an attempt to cool the instruments as much as possible and still collect mapping data, a thermal strategy was employed whereby the HGA was used to shield, or "hide," the rest of the spacecraft from the Sun to allow cooling. Beginning with orbit 1950 (upload M1107), each mapping pass was shortened so that the spacecraft could be rotated and the instrument panels shaded. For each successive upload after M1107, the mapping passes became shorter. This allowed the instruments to be shaded from the Sun by the HGA. A variation of this technique, which was referred to as "two hides," provided two such cooling periods.

Transmitter-A Failure

On January 4, 1992, transmitter A on board the spacecraft failed during the playback of orbit 3880. The redundant transmitter B had previously been shut down in March 1991 when a narrow-band spurious oscillation began appearing in the telemetry signal. This so-called "spike" was probably the result of a thermal problem which had allowed the transmitter to become too hot. As a result of the failure of transmitter A, mapping data from orbit 3881 through the end of Cycle 2 (orbit 3962) were lost. Transmitter B was used for the remainder of the SAR data collection, and the quality of received data continued to degrade throughout, despite efforts by DSN personnel to maximize collection.

After the behavior of transmitter B was studied, the transmitter was turned off with the hope that its operative capability would be preserved until the only significant remaining gap could be filled in September 1992. Thus, mapping for uploads M2192, M2206, and M2220 was sacrificed.

ASTRONOMICAL EVENTS

Superior Conjunction during Cycle 1

Superior Conjunction occurs once every 583.92 days for Venus. Superior Conjunction affected telemetry quality when the Sun-Earth-spacecraft (more generically, the Sun-Earth-

probe, or SEP, angle) was less than about 5°. During this period, transmissions could not be received from or sent to Magellan. Superior Conjunction occurred during the end of October and the beginning of November 1990. The result was a loss of 110 orbits (orbits 677 through 786). Another Superior Conjunction occurred at the end of Cycle 3, affecting orbits 4986 through 5163.

Apoapsis Occultation

Apoapsis Occultation occurred approximately once every one and one-half cycles (2700 orbits). During this period, the spacecraft's signal on Earth was blocked by Venus during data playback, making communication with the spacecraft impossible. During Cycle 1, Apoapsis Occultation affected data during orbits 1046 through 1354, resulting in a shortening of the playback of mapping data. Apoapsis Occultation occurred again around orbit 3700, but at this time, mapping was heavily constrained from the transmitter failure and was not, therefore, affected by Apoapsis Occultation.

SPECIAL TESTS

Throughout Cycles 1 and 2, Magellan performed several special tests aimed at collecting different types of scientific and engineering information. The goal of these tests was to examine candidates for different data collection modes that might be used later in the mission.

Interferometry Test

The interferometry test bridged the end of Cycle 1 and the beginning of Cycle 2, orbits 2159 through 2171, in upload M1135. This upload contained radar commands designed to lengthen the burst period in a portion of each orbit to enhance the possibility of producing data that would coherently interfere with those acquired at the beginning of Cycle 1. If burst echoes could be made to interfere, the phase history of each pixel involved could be preserved, and pixel elevation information could be derived. Thus, the interferometric mode could potentially produce limited but high-resolution surface topographic information (Li et al., 1990). The basic image data records (BIDRs) associated with these orbits were processed with the standard SDPS software, which was not designed to properly use the longer bursts, and therefore the image data in the affected area (extending approximately from +50° to +45° latitude) are substandard.

High-Resolution Radar Test

The second test performed during Cycle 2 used a SAR mode with PRFs and burst lengths modified to improve azimuth resolution from the nominal 120 m to 60 m at the expense of reduced swath width, which would produce higher resolution image data. This test was executed during special upload M1193B covering orbits 2582 through 2586, from the start of mapping to -30° latitude. The BIDR products generated from these orbits have the exact same format as the normal BIDR except in the following areas on image files 13 and 15:

- The pixel spacing for the "Hi-Res" image data is 25 m in each dimension instead of the usual 75 m. Therefore, the image line length is much greater. The line length in the "Hi-Res" F-BIDR varies from one image block to another, but the maximum line length is capped at 3200 pixels.
- The number of image lines per image block in the "Hi-Res" F-BIDR also varies from image block to image block. However, the maximum number of pixels per image block is capped at 640,000.

Stereo Test

The third test performed during Cycle 2 was executed during upload M1205 and covered orbits 2674 through 2681. This was an evaluation of Magellan's stereo abilities. A special left-looking DLAP was designed for this test to yield stereo pairs when used with the nominal left-looking DLAP (see Section 4).

Polarimetry Test

For a series of four consecutive orbits (3716 through 3719), the spacecraft was rotated 90° about the HGA boresight as a test of the utility of polarimetric data. The resulting data are VV (vertically polarized transmit, vertically polarized receive) with the electric field vector oriented 90° to the nominal left-looking data acquired over the same terrain during Cycle 1 (Giuli, 1986). The coverage extended over Theia Mons and Rhea Mons in Beta Regio. Due to the 90° rotation, no altimetry data were taken over these orbits. A second polarimetry test was conducted during Cycle 3, covering orbits 4567 through 4574 (upload M2097).

Table 6.3 summarizes the orbit range and upload number for each of the special tests discussed.

Table 6.1.A. Comments on Individual Swaths (Cycle 1).

ORBIT(S)	LONGITUDE(S),* DEGREES	UPLOAD NUMBER(S)	NOTES
376	332.2	M0258	First mapping orbit in Cycle 1.
416	340.4	M0262	ALT-EDRs for this orbit are mislabeled.
452-455	247.3-347.9	M0268	Radar Test 5: no mapping data exist for these orbits.
467	350.0	M0269	ALT-EDRs for this orbit are mislabeled.
475	351.8	M0269	ALT-EDRs for this orbit are mislabeled.
489	354.8	M0272	ALT-EDRs for this orbit are mislabeled.
490-491	355.0-355.2	M0272	The majority of data in these orbits were lost due to a DSN power outage at the Madrid DSN station.
577	12.6	M0283	ALT-EDRs for this orbit are mislabeled.
589	15.2	M0286	ALT-EDRs for this orbit are mislabeled.
650-1097	26.9-117.0	M0293- M0353	Gradual degradation of the DMS-A tape recorder resulted in an increase in corrupted data and gaps.
677-786	32.6-64.5	M0297- M0311	Superior Conjunction; there are no data for these orbits.
787	54.7	M0311	First mapping orbit after Superior Conjunction.
787-816	54.7-60.5	M0314	A bad threshold caused a white patch in these orbits at approximately 14°. The patches were approximately 0.5° in length.
788	54.9	M0314	This orbit was severely off-pointed due to Superior Conjunction. As a result, the orbit was disapproved by MOSST for inclusion in mosaicked products.
788	54.9	M0314	Significant degradation of the DMS-A tape recorder.
789	55.1	M0314	This orbit contains much bad data due to low SNR at the DSN station.
813	59.9	M0314	This orbit ended 25° early due to a DSN outage.
814	60.1	M0314	This orbit was lost due to a DSN outage.
815	60.3	M0314	The first 20° of this orbit is missing due to the DSN outage associated with orbits 813-814.
825-826	62.3-62.5	M0318	These orbits were lost in a spacecraft emergency on November 15, 1990.

* These are equatorial longitudes covered by the orbit(s) listed.

Table 6.1.A. Comments on Individual Swaths (Cycle 1) (Cont.).

ORBIT(S)	LONGITUDE(S),* DEGREES	UPLOAD NUMBER(S)	NOTES
827-828	62.7-62.9	M0318	These orbits were processed but they contain severe problems as a result of the November 15, 1990, spacecraft emergency. These orbits were disapproved by MOSST for inclusion in mosaicked products.
849	67.1	M0321	Although this was a successful mapping orbit, version 1 of the F-BIDR was only processed to -60°. Version 2 was processed to -79° (the complete orbit).
850	67.3	M0321	Although this was a successful mapping orbit, version 1 of the F-BIDR was only processed to -20°. Version 2 was processed to -52° (the complete orbit).
888-891	75.0-75.6	M0325- M0328	These orbits were lost during a spacecraft commanding error on November 23, 1990.
929	83.2	M0332	Approximately 9° of data is missing due to the DMS-A tape recorder problem.
941-970	85.6-91.5	M0335	A misplaced burst caused image discontinuity at +89.5°. This was the effect of a commanding error associated with upload M0335.
942	85.8	M0335	Approximately one-half of this orbit was lost in a bad star calibration on December 1, 1990.
943-945	86.0-86.4	M0335	These three orbits were lost during a bad star calibration on December 1, 1990.
946	86.6	M0335	This orbit contains cross-track shading throughout the entire swath due to an approximate 0.7° antenna off-point. In addition, the first 10° of this orbit was lost in the bad star calibration on December 1, 1990.
1020	101.3	M0342	Beginning of irrecoverable DMSA data.
1046-1354	106.7-168.6	M0349- M1023	Apoapsis Occultation. Subsequently, these orbits begin at +71° instead of +89°. These orbits also have a broader swath beginning at -42.5° and continuing to the bottom of the orbits.
1098	116.5	M0356	This was the first orbit that used the one-tape-recorder (DMS-B) strategy instead of the two-tape-recorder strategy used previously.
1245	146.7	M1009	Three-minute gap at the beginning of this orbit was due to an onboard switch of the TWTA.

* These are equatorial longitudes covered by the orbit(s) listed.

Table 6.1.A. Comments on Individual Swaths (Cycle 1) (Cont.).

ORBIT(S)	LONGITUDE(S), * DEGREES	UPLOAD NUMBER(S)	NOTES
1250	147.7	M1009	This orbit was only processed through the EDR stage. Subsequent processing was not done because of an approximate three-minute change in radar commanding relative to spacecraft location.
1251-1301	147.9-157.9	M1012- M1016	These orbits contain an extra tape recorder gap that is approximately 1° in length due to the DMS block strategy used in the command procedure.
1302	158.1	M1019	To avoid a miscalculation discovered late in the sequence generation process, this orbit was recorded as a delayed orbit, thus making 1301-1303 all delayed mapping swaths. Orbit 1302 has begin and end latitudes of +54.5° and -61° instead of the +77.4° and -39.9° typical of immediate orbits in this upload.
1302-1354	158.1-168.6	M1019- M1023	These orbits contain an extra tape recorder gap that is approximately 1° in length due to the DMS block strategy used in the command procedure.
1341	165.9	M1023	21° of data was lost due to a late lockup at the DSN.
1355-1403	168.8-178.4	M1026- M1030	Swaths within this range are 35 km wide from +90° to +80° in order to support pole location studies.
1390	175.8	M1030	This orbit contains seven minutes of missing data.
1415	180.8	M1033	Approximately one-quarter of this orbit was lost due to a power outage at the DSN station.
1486-1607	195.3-219.5	M1044- M1058	These orbits are missing the final 10 minutes of mapping playback. This is due to the early turn from mapping to fix the thermal problem. However, the radar was left on after the early turn.
1508	199.5	M1047	Forty-five minutes of playback were lost due to weather conditions at the DSN station.
1564-1588	210.8-215.6	M1054	Orbits in this range are approximately 0.2° off-pointed.
1630	224.1	M1061	The second half of this orbit was lost due to a bad star calibration on March 4, 1991.

* These are equatorial longitudes covered by the orbit(s) listed.

Table 6.1.A. Comments on Individual Swaths (Cycle 1) (Cont.).

ORBIT(S)	LONGITUDE(S),* DEGREES	UPLOAD NUMBER(S)	NOTES
1631-1633	224.3-224.7	M1061	These orbits were lost during a bad star calibration on March 4, 1991.
1634	224.9	M1061	Approximately one-half of this orbit was lost during a bad star calibration on March 4, 1991.
1674-1698	232.9-237.7	M1068- M1072	A transmitter problem (transmitter B) caused significant portions of these orbits to contain corrupted data and gaps.
1739	245.9	M1075	2.7 minutes of data were lost due to wind and snow at the DSN station.
1740	246.1	M1075	2.5 minutes of data were lost due to wind and snow at the DSN station.
1746	247.4	M1079	18.2 minutes of data were lost due to wind and snow at the DSN station.
1761	250.4	M1079	This orbit was off-pointed by approximately 0.3° due to missed star calibrations in previous orbits.
1798	257.8	M1086	22.9 minutes of data were lost due to snow at the DSN station.
1799	258.0	M1086	1.8 minutes of data were lost due to snow at the DSN station.
1950-2165	288.2-331.6	M1107- M1135	Thermal hiding period; swath shortened and all swaths begin at north pole.
1971	292.6	M1110	This orbit contains 12 minutes of missing playback due to a missing ODR.
2119-2127	322.4-324.0	M1128	These orbits were lost during a spacecraft walkabout on May 10, 1991.
2128	324.2	M1128	This orbit was off-pointed by 1.7° due to the May 10, 1991, spacecraft walkabout.
2159-2171	330.4-332.8	M1131- M1135	A radar/interferometry test was performed during these orbits. Consequently, these orbits contain bad radar data between +50° and +45°.
2165	331.6	M1135	Final orbit in Cycle 1.

* These are equatorial longitudes covered by the orbit(s) listed.

Table 6.1.B. Comments on Individual Swaths (Cycle 2).

ORBIT(S)*	UPLOAD NUMBER(S)	NOTES
2149–2175	M1135	Interferometry test: bad SAR data 50° N to 45° N latitude.
2159–2175	M1135	Interferometry test: bad SAR data 50° N to 45° N latitude.
2166	M1135	First orbit which intersects 376.
2166–2218	M1135–M1138	Left-looking mapping, nominal mapping.
2172–2175	M1135	Orbit trim maneuver (see description in Section 6).
2219	M1143	First right-looking orbit.
2219–2464	M1143–M1174	Right-looking mapping.
2270	M1150	This orbit was lost due to wind at the DSN.
2338–2365	M1160	Possible pointing error could result in bad SAR data.
2465–2581	M1177–M1188	Filling the Cycle-1 Superior Conjunction gap. Left-looking mapping with nominal Cycle-1 parameters.
2582–2586	M1193B	High-resolution test.
2587	M1193E	Switched back to right-looking parameters.
2587–2673	M1193E–M1201	Right-looking mapping.
2649	M1201	Lost in spacecraft anomaly.
2674–2681	M1205	Stereo test.
2682	M1206	Right-looking mapping resumes.
2682–3211	M1206–M1277	Right-looking mapping.
2682–3300	M1206–M1288	Used topographic model 5.2 which caused a processing problem.
2775–2850	M1218–M1228	Correlation problem caused small gaps surrounding equator (recoverable); also shading problem due to topographical error.
2913–2936	M1235	Shortened swath due to DMS heating.
2926–2936	Q1239	180° roll around radar boresight prior to mapping start — loss of altimetry data.
2937–2998	M1241	20-minute “two-hides.”
2939–2974	Q1241	180° roll around boresight prior to mapping start — loss of altimetry data.

* Right-looking orbits during Cycle 2 did not cover the equatorial region of Venus. Therefore, no equatorial longitude is included for these orbits.

Table 6.1.B. Comments on Individual Swaths (Cycle 2) (Cont.).

ORBIT(S)*	UPLOAD NUMBER(S)	NOTES
2975–2976	R1246	180° roll around boresight prior to mapping start — loss of altimetry data.
3212–3213	M1277	Radio-science experiment —no effect on normal mapping.
3214–3668	M1277–M1340	Right-looking mapping.
3256	M1284	Orbit was off-pointed.
3256–3283	M1284	Modified to start mapping five minutes early to cover Maat Mons; later adjusted to optimize radar over steepest part of Maat Mons.
3291–3298	M1289C	Modified radar parameters in order to image the steepest portion of Maat Mons.
3669–3715	M1340–M1344	Left-looking nominal mapping.
3716–3719	M1347B	Polarimetry test.
3720–3954	M1347D–M2014	Left-looking nominal mapping resumes following polarimetry test.
3801	M1354	Lost in DSN Christmas shutdown.
3856–3858	M1362	Lost in DSN New Year’s shutdown.
3880	M2001	Final orbit prior to the failure of transmitter A. The remainder of the BIDs in Cycle 2 were disapproved.
3954	M2014	1546 SAR bursts on the XEDR.
3955	M2014	1379 SAR bursts on the XEDR.
3958	M2014	808 SAR bursts on the XEDR.
3962	M2014	Final orbit in Cycle 2 — two SAR bursts on the XEDR.

* Right-looking orbits during Cycle 2 did not cover the equatorial region of Venus. Therefore, no equatorial longitude is included for these orbits.

Table 6.1.C. Comments on Individual Swaths (Cycle 3).

ORBIT(S)*	UPLOAD NUMBER(S)	NOTES
4037	M2024	0.66 minute of data missing from start.
4043	M2024	First 3.8 minutes missing — late lock.
4080	M2024	Some trouble locking up after occultation.
4089	M2024	Last 37 seconds missing from the XEDR.
4091	M2024	About 65 seconds of gap at the 43/63 transition. (Latitude range +64.6° to +60.4°.) First 2.3 minutes of 63 data are corrupted (1/3 bursts are missing), but improves after occultation.
4094	M2024	Only partly covered by DSS 12; last 7.3 minutes gone.
4108	D2031	First 1.8 minutes not covered by DSS 15. Data corrupted before occultation gap.
4109–4131	D2035B	Special left-looking, high incidence angle DLAP to cover the territory over Maxwell Montes.
4132–4160	M2038	Left-looking, stereo incidence angle mapping.
4145	M2038	Unexpected 43-second gap at latitude +8.7°.
4156	M2038	Rain at DSS 42 caused negative SNRs at the beginning of the orbit.
4172	D2042	First 2.8 minutes not covered by DSS 63. Following this, there are 1.2 minutes of corrupted data.
4178	D2042	0.65 minute of the missing data is from a single gap as the DSN tried to get lock following occultation.
4209	D2045	Low SNRs (SNR < 0 dB) at the start of the pass.
4210	D2045	Somewhat low SNRs (SNR < 2 dB).
4223	D2049	A 0.61-minute gap at the B2–B3 track transition.
4317	D2063	Only the last 80 seconds were covered by DSS 43.
4318	D2063	Only the first 7.8 minutes (record time) were covered by DSS 43.
4330	D2063	First 14.3 minutes missing (includes occultation).
4331	D2063	First 14.4 minutes missing (includes occultation).
4353	D2066	Data very bad at the end as the SNRs dropped below –1.0 dB. Trouble locking up after occultation.
4355	D2066	Poor data overall; end of orbit very bad with SNRs < –1.0 dB.
4356	D2066	Only six bursts in the orbit.
4360	D2066	Only partially played back; 3.9 minutes missing at the start; 2.4 minutes missing at the end.

* Orbits during Cycle 3 did not cover the equatorial region of Venus. Therefore, no equatorial longitude is included for these orbits.

Table 6.1.C. Comments on Individual Swaths (Cycle 3) (Cont.).

ORBIT(S)*	UPLOAD NUMBER(S)	NOTES
4361	D2066	First .77 minute missing; last 7.93 minutes missing.
4367	D2066	First 5.92 minutes missing.
4368	M2070	First 3.51 minutes missing.
4379	M2070	Track 4 bad.
4384	M2070	Track 4 poor (Standard Station).
4385	M2070	Track 4 completely gone; track 3 poor.
4417	D2073	Track 4 poor, others good.
4421	D2077	Track 4 poor.
4455	M2080	Poor data (Standard Station). 1.8-minute gap at start; late lock.
4456	D2082	Poor data; track 4 completely gone (Standard Station).
4462	D2083	Trouble locking up on first half of the orbit; first two tracks completely gone.
4482	D2083	Gap in Track 1 due to low elevation plus TPA trouble.
4483	D2083	DSS 65 reported snow.
4487	D2083	Poor data (Standard Station) on first two DMS tracks.
4488	D2083	Poor data (Standard Station).
4508	D2087	Good data except for DMS track 4.
4523	D2091	Poor data except for DMS track 4.
4581	D2098	Last track missing.
4592	D2098	Standard Station — no data.
4593	D2098	Standard Station — no data.
4610	D2101	Very poor data (90% missing).
4611	D2101	Very poor data (90% missing).
4619	D2101	Very poor data (95% missing).
4620	D2101	Very poor data (95% missing).
4630	D2105	34-m HEF station — no data.
4631	D2105	34-m HEF station — no data.
4632	D2105	Array test, DSS 12 and 15 — First 0.7 minute missing. SNR down in track 4.

* Orbits during Cycle 3 did not cover the equatorial region of Venus. Therefore, no equatorial longitude is included for these orbits.

Table 6.1.C. Comments on Individual Swaths (Cycle 3) (Cont.).

ORBIT(S)*	UPLOAD NUMBER(S)	NOTES
4639	D2105	Swapped to TWTA-B. Data quality improved. SNR approximately -0.5 dB for first two tracks, lower after star calibration. Track 4 — SNRs very low.
4640	D2105	Continued with TWTA-B.
4647–4675	M2108	No good high rate; 180° rolled left stereo.
4676–4684	D2112	No good high rate; 180° rolled left stereo.
4685–4697	D2113	No good high rate; -90° rolled left stereo.
4698–4726	D2115	Some good high rate; -90° rolled left stereo.
4728	D2119	Very poor data. SNRs -1.0 to -1.6 dB.
4729	D2119	Very poor data. SNRs -1.2 to -2.0 dB.
4737	D2119	Poor data. SNRs -0.5 to -1.0 dB. About half of the data is present for the last two tracks.
4738	D2119	First two tracks have about 60% of the data present. SNRs start at around -0.3 dB, sink to -1.8 dB by the end of the orbit.
4742	D2119	This orbit used for DSN test. The test raised SNR to +1.5 dB on track 3, which is why this track is only missing 1.38 minutes.
4743	D2119	Good data. Phase adjustment at DSS 15 kept SNR around +1.5 dB for most of the orbit.
4750–4778	M2122	-90° rolled left stereo.
4766	M2122	Poor data; SNRs -0.3 to -1.3 dB. Tracks 2 and 3 might be okay. (No phase tweak this orbit.)
4767	M2122	Poor data. SNRs -0.2 to -0.8 dB. Track 3 may have some decent image data, however. (No phase tweak this orbit.)
4772	M2122	Good data. SNRs +0.2 to +1.2 dB.
4773	M2122	Very good data. SNRs +0.6 to +1.6 dB.
4779–4800	D2126	-90° rolled left stereo.
4781	D2126	Very good data. SNRs +0.9 to +1.8 dB.
4782	D2126	Very good data. SNRs +0.6 to +1.6 dB.
4801–4829	D2129	-90° rolled left stereo.
4813	D2129	First DMS track and part of the second were not covered by DSS 61/65.
4830–4852	D2133	-90° rolled left stereo.

* Orbits during Cycle 3 did not cover the equatorial region of Venus. Therefore, no equatorial longitude is included for these orbits.

Table 6.1.C. Comments on Individual Swaths (Cycle 3) (Cont.).

ORBIT(S)*	UPLOAD NUMBER(S)	NOTES
4833-4834	D2133	Good data. Most SNRs +2.0 to +2.5 dB; short SNR drop before star calibration.
4840	D2133	Very good data. SNRs +1.2 to +2.1 dB. (First 16 seconds during lockup.)
4853-4881	M2136	-90° rolled left stereo.
4882-4903	D2140	-90° rolled left stereo.
4904-4918	D2143	-90° rolled left stereo.
4913	D2143	0.58-minute gap at the very start.
4919-4920	D2145	SNRs around +5 dB, but still missing > 1 minute.
4919-4921	D2145	High-resolution altimetry.
4922-4955	D2146	-90° rolled left stereo.
4936	D2146	3.24-minute gap at start.
4956-4985	D2150	-90° rolled left stereo.
4986-5163	M2154	Superior Conjunction.
5179	M2178	Very poor data. SNRs -2.0 to -0.5 dB.
5180	M2178	Poor data; okay for track 4.
5189	M2178	Late lock due to TPA (DSN) trouble.
5190	M2178	Missing more bursts and RCDs than expected given the high SNRs.
5194	D2182	Poor data. SNRs -1 to 0 dB.
5195	D2182	Poor data. SNRs -1.5 to 0 dB.
5200	D2182	Poor data. SNRs -1.8 to -0.8 dB.
5201	D2182	Very poor data. SNRs -1.8 to -1.2 dB
5245	D2189	Almost completely gone. Except small portion of track 4, SNR < -2 dB.
5253	D2189	Almost completely gone. Except small portion of track 4, SNR < -2 dB.
55XX	M2234	End of mapping until thermal gap fill.
5670-5747	M2247-M2255	Filling of thermal gap.
5671	M2247	Missing last 30 seconds.
5672	M2247	Missing first 35 seconds.

* Orbits during Cycle 3 did not cover the equatorial region of Venus. Therefore, no equatorial longitude is included for these orbits.

Table 6.1.C. Comments on Individual Swaths (Cycle 3) (Cont.).

ORBIT(S)*	UPLOAD NUMBER(S)	NOTES
5687	M2247	Missing last 30 seconds.
5695	M2250	Missing first 22 seconds and last 30 seconds.
5705	M2250	Missing first 75 seconds and last 30 seconds.
5706	M2250	Missing first 17 seconds.
5743	M2255	Missing last 30 seconds.
5747	M2255	Last SAR orbit.
7625	—	Last gravity orbit prior to aerobraking.
7626	—	Beginning of aerobraking.

* Orbits during Cycle 3 did not cover the equatorial region of Venus. Therefore, no equatorial longitude is included for these orbits.

Table 6.2. DMS Gaps.

UPLOAD NUMBER(S)	ORBIT RANGE	IMMEDIATE SWATH GAPS, DEGREES	DELAYED SWATH GAPS, DEGREES
M0356	1098–1147	18.4 to 18.0, 40.7 to 40.4, –4.5 to –4.9	12.4 to 12.1, –10.3 to –10.8, –31.4 to –31.6
M0363, M1005	1148–1250	17.3 to 17.0, 38.7 to 38.0, –4.4 to –4.0	–9.3 to –9.7, 12.4 to 12.1, –29.4 to –29.7
M1012	1251–1301	–10.6 to –10.9, 21.6 to 21.2, 52.0 to 51.8	24.5 to 24.2, –37.0 to –37.2, –7.7 to –8.0
M1019	1302–1354	–9.1 to –9.5, 25.0 to 24.0, 56.6 to 56.0	–41.8 to –42.0, –11.4 to –11.8, 22.7 to 22.3
M1026–M1103	1355–1949	25.1 to 24.8, 63.2 to 63.0, –16.6 to –17.0	15.6 to 15.2, –58.2 to –58.6, –25.5 to –25.8
M1107–M1110	1950–2001	31.3 to 31.0, –7.1 to –7.0	8.0 to 30.5, –7.6 to –7.9
M1114–M1117	2002–2054	–0.3 to –0.6, 35.6 to 35.0	–0.7 to –1.0, 35.2 to 35.0
M1121–M1124	2055–2106	16.6 to 16.3, 46.1 to 45.0	16.2 to 15.9, 45.7 to 45.5
M1128–M1135	2107–2175	55.8 to 55.6, 33.2 to 32.0	55.5 to 55.3, 32.8 to 32.4
M1143	2219–2234	–51.65 to –51.75, –58.95 to –59.05	–84.75 to –85.4
M1145–M1150	2235 to 2293	–51.65 to –51.75	–73.85 to –74.35, –58.95 to –59.0
M1154	2294–2313	–51.75 to –51.85	–75.0 to –75.24
M1156–M1160	2314–2365	–51.8 to –52.05, –59.15 to –59.2	–74.1 to –74.5
M1163–M1174	2366–2464	–46.05 to –46.30, –54.55 to –54.75	–72.3 to –72.7
M1177–M1180	2465–2519	27.7 to 28.0, 1.8 to 2.2, –22.65 to –23.0	27.7 to 28.0, 1.8 to 2.2, –22.65 to –23.0
M1184–M1193B	2520–2586	28.5 to 29.0, 1.85 to 2.3, –23.3 to –23.6	28.5 to 29.0, 1.85 to 2.3, –23.3 to –23.6
M1193E–M1197	2587–2642	–37.5 to –37.6	–55.8 to –55.9
M1201–M1206	2643–2688	–19.5 to –20.15	–20.0 to –20.2, –49.75 to –50.5
M1207–M1239	2689–2936	44.6 to 44.75, 3.4 to 3.8, –36.1 to –36.25	0.75 to 1.10, –38.4 to –38.6

Table 6.2. DMS Gaps (Cont.).

UPLOAD NUMBER(S)	ORBIT RANGE	IMMEDIATE SWATH GAPS, DEGREES	DELAYED SWATH GAPS, DEGREES
M1241–M1246	2937–2998	–77.4 to –77.9, –61.1 to –61.3, –41.3 to –41.35	–77.4 to –77.9, –61.1 to –61.3, –41.3 to –41.35
M1249–M1260	2999–3101	–25.75 to –26.0	–25.75 to –26.0
M1263–M1267	3102–3152	–31.0 to –31.2, –55.7 to –55.9	–31.0 to –31.2, –55.7 to –55.9
M1270–M1274	3153–3204	–30.9 to –31.2	–30.9 to –31.2, –75.6 to –75.8, –55.6 to –56.0
M1277–M1281	3205–3255	–33.6 to –33.75, –57.2 to –57.5	–33.6 to –33.75, –57.2 to –57.5
M1284–M1295	3256–3358	–20.3 to –20.6, –64.0 to –64.5, –44.4 to –45.0	–20.3 to –20.6, –64.0 to –46.5, –44.4 to –45.0
M1298–M1309	3359–3461	–32.5 to –32.7, –56.6 to –57.0, –75.8 to –76.0	–32.5 to –32.7, –56.6 to –57.2, –75.8 to –76.5
M1312–D1337	3462–3667	–36.2 to –36.3, –50.7 to –51.0, –63.2 to –63.0	–61.5 to –62.3, –72.7 to –73.3, –82.9 to –83.4
M1340–M1344	3668–3715	–28.8 to –28.9, –50.4 to –50.0, –67.1 to –67.0	–28.8 to –28.9, –50.4 to –50.7, –67.1 to –67.4
M1347B	3716–3719	No gaps — polarimetry test.	
M1347D–M1351	3720–3770	–28.9 to –29.0, –50.5 to –50.0, –67.5 to –67.0	–28.9 to –29.0, –50.5 to –50.8, –67.5 to –67.8
M1354–M2001	3771–3880	–21.6 to –21.8, –46.7 to –46.0	–21.6 to –21.8, –46.7 to –46.9

Table 6.3. Special Tests.

TEST	ORBIT RANGE	UPLOAD NUMBER
Interferometry Test	2166–2175	M1135
High-Resolution Radar Test	2582–2586	M1193B
Stereo Test	2674–2681	M1205
Radio-Science Test	3212–3213	M1277
Polarimetry Test	3716–3719 4567–4574	M1347B M2097C

Data Product Description

A large number of data products come from the data acquired by the Magellan spacecraft. For the purposes of this guide, the SAR-related products fall into three general categories: interim products used in the production of uploads or other Project needs; products directly useful for science or engineering analysis; and products that, while not useful for analysis, may be required indirectly by data analysts. An example of the latter category is the archive engineering data record (AEDR), which contains the spacecraft's engineering telemetry. This product might be required if it were necessary to determine whether a peculiarity in the science data is related to some spacecraft activity or is related to the Venusian surface. Those products deemed useful for science analysis and most of those that might be required indirectly are cataloged and archived, and are available to the public through NASA archive facilities.

The NASA archiving system has three components: the Regional Planetary Image Facilities (RPIFs), the Planetary Data System (PDS), and the National Space Science Data Center (NSSDC). Briefly, RPIFs are centers located around the world where planetary data may be browsed but generally may not be removed. PDS is a catalog center that can help the investigator locate specific pieces of information. Finally, NSSDC is the location of planetary data archives. For more information about using these three facilities, see Appendix 3.

Each of the separate data product types is described in detail by a document called a Software Interface Specification (SIS). A list of Magellan-specific SISs is shown in Table 7.1. The SISs are written with two objectives. First, the SIS and its references contain all information required to write software to read the data product. The file and record structures are described at the bit level. Second, the SIS provides low-level information about the meaning of the data. Units, derivation methods, processing algorithms, and references to such information are contained in the product SIS. Product SISs may be ordered from the PDS Geosciences Node or from NSSDC, as explained in Appendix 3.

As the Magellan data processing proceeded from one step to the next, many data segments were transferred intact from one data product to the next, either unchanged or slightly modified. In order to reduce duplication, SISs for data products containing inherited files or data simply make reference to other SISs. As a result it may be necessary for the analyst to obtain several SISs to fully understand one product, and the full list of required SISs might not be clear

from the outset. To make this process simpler, a cross-index of SISs which refer to each other is provided in Appendix 4.

Magellan imaging data were acquired by the DSN as they were played back from the spacecraft. Each one-hour playback period was simultaneously recorded on ODRs, which were shipped to JPL. ODR tapes and other ancillary files were used to generate EDRs, which contain no multiple copies of data (as might have existed, for example, when multiple DSN stations received Magellan's telemetry). Three distinct types of EDRs were made. They are as follows:

- The SAR-EDR, which contains not only SAR data from the radar sensor but also all ancillary data necessary to turn SAR data into images, including navigation data, sensor engineering data, and information from the radar control parameter generation task.
- The altimeter experiment data record (ALT-EDR), which similarly contains all data necessary to process the altimetry and radiometry data.
- The AEDR, which contains all spacecraft and radar engineering data for placement into the Project archive.

The SAR echoes contained on each SAR-EDR were transformed into a single strip of image data representing a Venusian surface area about 20 km wide and about 15 by 1000 km long, which is the F-BIDR. The F-BIDR, which is discussed in detail in the following section, is the most basic Magellan image data product. On the F-BIDR, each 8-bit byte contains one pixel, which represents a 75-m patch of surface area. Pixels on the F-BIDR are located on the planet in latitude and longitude, calculated from navigation data contained on the SAR-EDR.

The Magellan data types thought to be most useful for science analysis are described in the following sections, beginning with the most common image data products. For all products, the respective SIS should be consulted when attempting to make quantitative use of the data.

BASIC IMAGES (BIDRS)

The BIDR is the most basic form of the Magellan SAR image data. As well as forming the foundation for all other image products, the BIDR is also the only product which contains a full set of ancillary data. In the files surrounding the image data on the BIDR are contained such supporting data as eph-

emerides, data quality, spacecraft pointing, SAR-processing inputs and output parameters, telemetry stream (including DSN) monitor data, and the like (see Table 7.2). The BIDR also preserves the Project's best efforts at radiometric and geometric calibration, and it provides tables translating from the natural coordinates of the SAR (for range and Doppler, see, e.g., Elachi, 1988) into the latitude/longitude coordinates. Location information on the BIDR was used to lay each pixel into image mosaics at various resolutions, as described in the following sections. The BIDR also contains radiometer measurements and data necessary for the calibration of those data.

There are actually many different forms of BIDRs (see Table 7.1), only two of which will be of common interest to the data analyst. The F-BIDR is the first product typically produced. It represents the full-resolution capability of the processed data. Arrays of 3-by-3 F-BIDR pixels were converted to power and averaged into single pixels on the compressed basic image data record (C-BIDR), whose pixel widths represent 225 m on the surface of the planet. The C-BIDR was produced as an interim product for production of mosaics, but the compression may be useful if full resolution is not desired.

The BIDRs, however, are extremely narrow swaths of image data. A typical F-BIDR may contain about 300 pixels east-west and 200,000 pixels north-south. Since they do not exactly represent a swath of constant longitude, the data within individual records on the BIDR are offset to avoid the use of excessive filler pixels, which prevents most conventional image-processing software from producing reasonable displays from them. An additional complication is that the offset for the first line in each image block is copied from the second line in the block. Refer to the BIDR SIS documents (listed in Table 7.1) for further details on reading BIDR data.

From a computer standpoint, an F-BIDR is a recording on 2400-foot reels of 6250-characters-per-inch (cpi) computer-compatible nine-track magnetic tape using the 6250-cpi Group Coding Recording Method (known as the GCR format) as specified by American National Standard (ANSI) X3.54-1976. A typical F-BIDR contains approximately 106 million bytes of image data and approximately 39 million bytes of ancillary data, and each product represents a single orbit. The SAR experiment was active for about 5630 orbits, most of which produced archivable F-BIDRs. At this writing an effort is being made to put the F-BIDR data set onto more dense media at the PDS Geosciences Node at Washington University, but the status of that effort is unclear.

As represented on the BIDR, pixels are a measure of the reflectance of the represented surface element, of diameter 75 m,¹ expressed in decibels, relative to a model of the average Venusian reflectance. Thus the byte representation of

each pixel (often referred to as the "data number," or DN) in the BIDR represents a number linear with the ratio of measured backscatter to modeled backscatter at the measurement's incidence angle (where incidence angle is relative to a spherical planet). The model, which varies with incidence angle, is used to compress the required dynamic range, which is largely due to the incidence angle variation with latitude (see Section 4). It was the Project's intention to use the model proposed by Muhleman, 1964, with parameters generated by Pettengill et al., 1988. The actual model in the SAR processor was different because of an error (Saunders et al., 1992, page 13,079), but the difference is slight, and as long as the correct function is used to decompress the data there is no additional loss of accuracy. Because the decibel scale is nonlinear, however, it is necessary to convert the pixel values into a value linear with measured power (or backscatter) before performing arithmetic operations such as averaging. Radiometric and geometric calibration accuracy of the BIDR data set is also discussed by Saunders et al., 1992.

To convert DNs from the BIDR into normalized radar backscatter cross-sections (Ulaby et al., 1982), use the following code fragment. This code correctly accommodates the model error and another lookup table error that was discovered in the SAR processor. Note also that a DN = 0 can represent either a valid measurement, processor underflow, or filler pixel, and that DNs from 252 through 255 are not used.

```

REAL THETA, DN, SIGNORM, MUHL, SIGMA, SIGDB
C
C ACCOMMODATE FOR SAR PROCESSOR ERROR IN INCIDENCE
C ANGLE LOOKUP C TABLE (ASSUMES THETA IS IN DEGREES).
NOTE ** DENOTES
C EXPONENTIATION.
C
C THETA = THETA + 0.5
C SIGNORM = 10 ** (((DN-1)/5 - 20) * .1)
C
C USE OF 0.0118 TERM MATCHES ERROR IN SAR
C PROCESSOR ALGORITHM. 0.0118 IS CORRECT
C MUHLEMAN LAW VALUE
C FOR AVERAGE VENUS. NOTE THAT THE FUNCTIONS SIND
C AND COSD ARE TRIGONOMETRIC SINE AND COSINE OF THE
C ARGUMENT IN
C DEGREES.
C
C MUHL = (0.0118 * COSD(THETA))/((SIND(THETA) +
C 0.111 * COSD(THETA)) ** 3)
C
C UNDO MUHLEMAN FUNCTION NORMALIZATION
C
C SIGMA = SIGNORM * MUHL
C SIGDB = 10 * ALOG10(SIGMA)

```

¹ The surface area represented by a pixel differs from the radar resolution, which varies with latitude (see Section 4).

where

THETA = incidence angle in degrees (see preceding discussion)

DN = the data number (0–251)

SIGMA = the normalized radar backscatter coefficient, in power-linear units

SIGDB = the normalized radar backscatter coefficient, expressed in decibels (Ulaby et al., 1982)

Geometrically, the BIDR contains two different projections. From +89° to –89° latitude, pixels are presented in equal-area sinusoidal projection, offset as already noted. From +80° to +90° latitude and from –80° to –90° latitude, the data are presented in oblique sinusoidal projection. The projection origin latitude for sinusoidal data is always the equator (0°). The projection longitude is given in the Data Annotation Label of the image files.

Begin and end latitudes vary for the BIDRs, both because of the immediate and delayed swath mission design (see Section 3) and because of various problems encountered during the mission (see Section 6). Table 7.2 shows the begin and end latitudes for BIDRs, and the associated longitudes can be determined from Table 6.1.A. Table 7.3 shows the BIDR file structure.

MOSAICKED IMAGES (MIDRS)

In order to maximize the scientific value of Magellan data, individual orbits were assembled to produce mosaicked products. Mosaicked products were created on several scales to illustrate areas of the surface ranging from a single feature to large volcanic flows. The smallest-scale mosaic corresponds to the scale of an F-BIDR. Mosaicked images produced from F-BIDRs are called full-resolution mosaicked image data records (F-MIDRs). To provide coverage for larger areas, the BIDR data were averaged in successive operations in which a single mosaic pixel was replaced by the average of nine pixels, creating compressed-once MIDRs (C1-MIDRs) with 225-m pixels, compressed-twice MIDRs (C2-MIDRs) with 675-m pixels, and compressed-thrice MIDRs (C3-MIDRs) with 2-km pixels. These mosaics allow scientists to have both high-resolution and more synoptic views (see Figure 7.1). Each MIDR frame is approximately 8000 pixels on each side, covering varying amounts of the surface according to the resolution of each pixel. Each C3-MIDR, for example, covers about one-sixth of the planet's surface. The C1-MIDRs, C2-MIDRs, and C3-MIDRs are often collectively called the C_n-MIDRs.

MIDRs are labeled according to the convention

aMIDR.bRc;v

where

a = "F," "C1," "C2," or "C3," according to the type of MIDR

b = the (nearest integer) center latitude of the frame (always positive)

R = "N" or "S," indicating whether b is north or south of the equator

c = the (nearest integer) center longitude of the frame, 0 < c < 360, positive east

v = the version number

During each mapping cycle, MIDRs were produced using the same grid centerpoints. To distinguish MIDRs from different cycles, the following procedure was implemented: Any MIDR whose version number is "1" or "10x" (where x is any digit from 1 to 9) was produced with Cycle-1 data. Beginning with data collected in Cycle 2, a three-digit cycle/version number was always employed. The resulting label identifications are in the form "aMIDR.bRc;dw" where d is the cycle in which the data used in that MIDR were collected and w is the version of that product. Versions range from "01" (the first version produced using data from that cycle) to "99."

For example, FMIDR.27S339;201 is an F-MIDR centered at 27° S latitude, 339° E longitude. Data in the MIDR were collected during Cycle 2, and this MIDR is the first version produced. In other examples, FMIDR.20N200;201 is the first version produced using Cycle-2 data, and FMIDR.20N200;202 is the second version produced using Cycle-2 data.

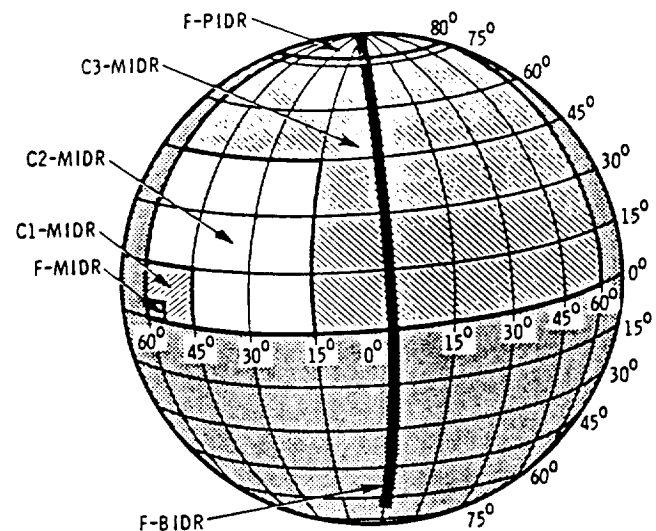

Figure 7.1. Magellan Image Products.

Largely for financial reasons, F-MIDRs were only produced over areas chosen by the science team; a total of about 25% of the planet was covered by these mosaics. However, the surface is fully represented in the *C_n*-MIDR set excluding only the polar areas where the polar mosaicked image data records (P-MIDRs) are used instead to allow the more convenient polar projection. A standard grid for mosaicked images of all scales was produced prior to the start of mapping, providing a basis by which products were created.

Engineering MIDRs

Prior to the start of standard MIDR production, a set of eight F-MIDRs was produced as a test of processing capabilities. These eight F-MIDRs were called "Engineering F-MIDRS" and are accessible digitally on MIDRCD.001. The label identifications of these Engineering F-MIDRs are as follows:

FMIDR.27S339;1	FMIDR.20N334;1
FMIDR.75N332;1	FMIDR.55N337;1
FMIDR.05S335;1	FMIDR.30N334;1
FMIDR.40S342;1	FMIDR.50S345;1

There are four distinguishing features of Engineering F-MIDRs: Engineering F-MIDRs consist of 20 orbits whereas standard F-MIDRs contain 24 orbits. Second, Engineering F-MIDRs are not necessarily complete on the trailing (right) edge and may contain missing orbits within the body of the mosaic that were processed later. The gap at the trailing edge of some of the F-MIDRs is a start of a mapping gap and is present because processing began with orbit 376. Gaps in the bodies of the F-MIDRs may be present because of the desire to process these mosaics early. Therefore, orbits that were more difficult to process appear as gaps in the Engineering F-MIDRs even though the orbit may have been processed later. Third, Engineering F-MIDRs were processed with earlier software versions and thus may not meet radiometric or other standards. Finally, the Engineering F-MIDRs which are included in MIDRCD.001 contain special processing label identifications (they were produced as "special products" as opposed to "standard products"). While standard F-MIDRs are identified through the MIDR label identifications (the MIDR type, centerpoint, and version of the product — such as FMIDR.10N200;1), the Engineering F-MIDRs are identified through the special product label identifications, as shown in Table 7.4.

MIDR Compact Disks

Magellan MIDRs are archived on compact optical disks, more commonly referred to as compact disks (CDs) or compact disk read-only memories (CD-ROMs). Other Magellan products — such as the altimeter/radiometer composite data record (ARCDR), the gridded global emissivity data record (GEDR), the global altimeter data record (GADR), the global

radiometer data record (GRDR), the global reflectivity data record (GREDR), the global slope data record (GSDR), and the global topography data record (GTDR) (which are often referred to collectively as the GxDRs) — are also archived on CDs. More than 100 such CDs contain the SAR images, and an additional set of more than 20 CDs contains the other data sets. Any of the CDs can be ordered from NSSDC, and specific ordering information is contained in Section 8 and Appendix 3. The CD-ROMs are largely self-documenting, with many included text files. The following excerpts, taken from the CD-ROM files, will give the prospective user an idea as to their structure.

The CD-ROMs are formatted so that a variety of currently popular computer systems (e.g., IBM personal computer [PC], Macintosh, Sun, and VAX) may access the data, and the format is general enough that future systems should be able to read them with little problem as long as the medium remains viable. Specifically, the CDs are formatted according to the International Standards Organization (ISO) 9660 level-1 Interchange Standard, and file attributes are specified by extended attribute records (XARs). For computer software that fully supports XARs, access to the CD-ROM volume will be straightforward; the disk will appear to the user to be identical to a file system of directories, subdirectories, and data files. Some computer systems that do not support XARs will ignore them; others will append the XAR to the beginning of the file. In the latter case the user must ignore the first 512 bytes of the file. For further information, refer to the ISO 9660 Standard Document (RF# ISO 9660-1988, April 15, 1988). All data formats are based on the *Planetary Data System Data Preparation Workbook* (Jet Propulsion Laboratory, 1991). For information specific to Magellan, refer to SISs IDPS-145, IDPS-107, and IDPS-109.

Each F-MIDR and *C_n*-MIDR is divided into an array of 56 framelets, arranged in seven rows and eight columns. The framelets are numbered in increasing order from left to right, top to bottom. Each framelet is 1024 lines by 1024 samples, with one byte per sample, and is stored in a separate file. The framelet files contain embedded VICAR2 labels and have detached PDS labels in accompanying files. The framelet files and supplementary data files for each MIDR are stored in a separate subdirectory. The MIDRs are all in sinusoidal equal-area map projection except P-MIDRs, which are in polar stereographic map projection.

Additional general information about each product is found in a *LABEL* directory. The *.*LBL* files in that directory contain the PDS catalog information for the Magellan mission, the spacecraft, the radar instrument, and the data sets.

Subsampled "browse" versions of the MIDRs are provided for quick inspection of the images, both in digital form on each CD and in photographic form in Appendix 5 of this guide. On the CDs, the browse version of each MIDR is found in the subdirectory for that MIDR. The file name for the browse image is *BROWSE.IMG*. Each browse image is 896 lines by 1024 samples and was created by averaging groups of 8-by-8 pixels in the original 7168-by-8192 MIDR. Browse images contain embedded VICAR2 labels and have detached PDS labels. The VICAR2 label is from the original 7168-by-8192 MIDR; therefore, corner points, map projection, and pixel size for label items may be inappropriate for the *BROWSE.IMG*.

All document files and detached label files contain 80-byte fixed-length records, with a carriage return character (ASCII 13) in the 79th byte and a line-feed character (ASCII 10) in the 80th byte. This allows the files to be read by the MacOS, DOS, UNIX, and VMS operating systems. All tabular files are also described by PDS labels, either embedded at the beginning of the file or detached. If detached, the PDS label file has the same name as the data file it describes, with the extension *.LBL*; for example, the file *CONTENTS.TAB* is accompanied by the detached label file *CONTENTS.LBL* in the same directory. The detached labels for MIDRs and GxDRs also contain PDS-defined map projection keywords that provide information needed to extract latitude and longitude values from given line and sample locations. Tabular files are formatted so that they may be read directly into many database management systems on various computers. All fields are separated by commas, and character fields are enclosed in double quotation marks (" "). Character fields are left justified, and numeric fields are right justified. The "start byte" and "bytes" values listed in the labels do not include the commas between fields or the quotation marks surrounding character fields. The records are of fixed length, and the last two bytes of each record contain the ASCII carriage return and line-feed characters. This allows a table to be treated as a fixed-length record file on computers that support this file type and as a normal text file on other computers.

PDS labels are object-oriented. The object to which the label refers (IMAGE, TABLE, etc.) is denoted by a statement of the form

`^object = location`

in which the caret character ("^," also called a pointer in this context) indicates that the object starts at the given location. In an embedded label, the location is an integer repre-

senting the starting record number of the object (the first record in the file is record 1). In a detached label, the location denotes the name of the file containing the object, along with the starting record or byte number if there is more than one object. For example:

```
^IMAGE_HEADER = ("C1F02.IMG",1)
^IMAGE = ("C1F02.IMG",3)
```

indicates that the IMAGE object begins at record 3 of the file *C102.IMG*, in the same directory as the detached label file. The following is a list of the possible formats for the ^object definition:

```
^object = n
^object = n<BYTES>
^object = ("filename.ext")
^object = ("filename.ext",n)
^object = ("dirlist]filename.ext",n)
^object = ("filename.ext",n<BYTES>)
^object = ("dirlist]filename.ext",n<BYTES>)
```

where

n = the starting record or byte number of the object, counting from the beginning of the file (record 1, byte 1)

<BYTES> indicates that the number is given in bytes

filename = the upper-case file name

ext = the upper-case file extension

dirlist = a period-delimited path-list of parent directories, in upper case, that specifies the object file directory (used only when the object is not in the same directory as the label file)

The list begins on the directory level below the root directory of the CD-ROM. [*dirlist*] may be omitted when the object being described is located either in the same directory as the detached label or in a subdirectory named *LABEL*, located one level below the CD-ROM root directory.

Files are organized in one top-level directory with several subdirectories. Table 7.5 shows the structure and content of these directories. In the table, directory names are enclosed in square brackets ([]), upper-case letters indicate an actual directory or file name, and lower-case letters indicate the general form of a set of directory or file names.

Cn-MIDRs and *F*-MIDRs are listed in Tables 7.6–7.11. Each table is segregated by MIDR type (*Cn*-MIDR or *F*-MIDR) and by mapping cycle. Within each table, the MIDRs are ordered first by degrees of latitude beginning at the equator and moving toward the poles — then by longitude from 0° to 360°.

For computers in common use in 1992, the following CD-ROM drives and driver software were tested and found to properly read the Magellan CD-ROMs. Information regarding appropriate driver software was current as of 1992, but subsequent drivers may be compatible as well.

- VAX/VMS

Drive: Digital Equipment Corporation (DEC) RRD40, RRD42, or RRD50.

Driver: DEC VFS CD-ROM driver V4.7 or V5.2 and up.

- VAX/Ultrix

Drive: DEC RRD40, RRD42, or RRD50.

Driver: Supplied with ULTRIX 3.1. Note: Use the *cdio* software package (in *~ftp/src/cdio.shar* from the *space.mit.edu* server).

- IBM PC

Drive: Toshiba, Hitachi, Sony, or compatible brand.

Driver: Microsoft MSCDEX 2.2. Note: The newest version of MSCDEX (released in February 1990) is generally available.

- Apple Macintosh

Drive: Apple CD SC (Sony) or Toshiba.

Driver: Apple CD-ROM driver. Note: The Toshiba drive requires a separate driver, which may be obtained from Toshiba.

- Sun Micro

Drive: Delta Microsystems SS-660 (Sony).

Driver: Delta Microsystems driver or SUN CD-ROM Driver.

Locating Data on the MIDRs

Because the MIDR data set is so large, and because the individual frames are placed on the disks by order of production, it can be difficult to locate specific features or locations without aid. Two computer-based aids have been created. The Magellan Hypermap, written at the Massachusetts Institute of Technology (MIT), locates features by name or by center latitude and longitude. The program lists MIDRs containing the requested site and identifies the proper CD for a selected MIDR. After the proper CD is mounted the program will launch another program which displays the image and allows basic image processing to be done or a separate file to be written in raw pixel, TIFF, PICT, PICS, or other file formats.

The Magellan Hypermap and the associated notepad stacks are available from the PDS Geosciences Node, whose address is listed in Appendix 3. The stacks are also available via Internet in electronic form from the *delcano.mit.edu* File Transfer Protocol (FTP) server; log on as an "anonymous" user in the *mgn/software* directory. You may also contact

Dr. Peter G. Ford
MIT Microwave Subnode
Tel: (617) 253-6485
Fax: (617) 253-0861
E-mail: pgf@space.mit.edu
or JPLPDS::PFORD

These stacks require HyperCard version 2.1 or later. The image display functions require at least 5 Mbytes of random access memory (RAM), an 8-bit (or deeper) frame buffer, and a floating-point unit (FPU).

Those wishing to implement the capability to access MIDRs by latitude and longitude in their own analysis programs may follow the following code fragments. (The quantities in bold type are available in the *.LBL* file accompanying each of the MIDR files on the CD.)

For a given F- or Cn-MIDR, the line and sample (i.e., the y and x coordinates in the image file, respectively) can be calculated from the desired latitude (LAT) and longitude (LON) using the following code:

```
SCALE = 6051000/MAP_SCALE
LINE = X_AXIS_PROJECTION_OFFSET-LAT*SCALE+0.5
SAMPLE = Y_AXIS_PROJECTION_OFFSET
        +(LON-CENTER_LONGITUDE)*SCALE*COS(LAT)+0.5
```

For the P-MIDRs, the corresponding codes depend on whether the frame is for the north or south pole. For the north pole,

```
PI = 3.1415926
SCALE = 6051000/MAP_SCALE
SAMPLE = Y_AXIS_PROJECTION_OFFSET+2*SCALE*SIN(LON-
CENTER_LONGITUDE)*TAN(PI/4-LAT/2)+0.5
LINE = X_AXIS_PROJECTION_OFFSET+2*SCALE*COS(LON-
CENTER_LONGITUDE)*TAN(PI/4-LAT/2)+0.5
```

For the south pole,

```
PI = 3.1415926
SCALE = 6051000/MAP_SCALE
SAMPLE = Y_AXIS_PROJECTION_OFFSET+2*SCALE*SIN(LON-
PROJ_LON)*TAN(PI/4+LAT/2)+0.5
LINE = X_AXIS_PROJECTION_OFFSET-2*SCALE*COS(LON-
CENTER_LONGITUDE)*TAN(PI/4+LAT/2)+0.5
```

ALPHABETICAL PRODUCT LISTING

Table 7.12 provides a complete list of products generated by the Magellan Project. For more information, refer to Yewell, 1993. Note that in the following descriptions, "tape" refers to 2400-foot reels of 6250-cpi computer-compatible nine-track magnetic tape using the 6250-cpi GCR format as specified by ANSI X3.54-1976. The CD-ROMs listed in the table are written in ISO 9660 format.

Table 7.1. Magellan SIS Documents.

ACRONYM	PRODUCT NAME	DOCUMENT NUMBER(S)	RELEASE DATE(S)
AEDR	Archive engineering data record	TPS-140	—
ALT-EDR	Altimeter experiment data record	TPS-101	—
ALT-TEDR	Temporary altimeter experiment data record	TPS-101	—
ALT-XEDR	Altimeter expedited experiment data record	TPS-101	—
AOEDR	Averaged orbital elements data record	NAV-136	—
ARCDR	Altimeter/radiometer composite data record	MIT-002	—
ARCDRCD	Altimeter/radiometer composite data record CD-ROM	IDPS-146	8/27/91
ARCDRW	Altimeter/radiometer composite data record WORM	MIT-002	—
ATDFDR	Archival tracking data record	TRK-105	—
BADR	Basic altimeter data record	IDPS-119	2/14/90, 8/7/90
BADRW	Basic altimeter data record WORM	IDPS-119	—
BOUGDR	Bouguer map data record	SCI-GRAV-104	—
BOUGMAP	Bouguer map	N/A	—
BRDR	Basic radiometer data record	IDPS-123	9/14/88, 8/31/90, 1/17/91
BRDRW	Basic radiometer data record WORM	IDPS-123	—
C-BIDR	Compressed basic image data record	IDPS-102	8/10/90, 1/17/91, 5/31/91
C-BIDRW	Compressed basic image data record WORM	IDPS-102	—
C1-MIDR	Compressed-once mosaicked image data record	IDPS-109	—
C1-MIDRW	Compressed-once mosaicked image data record WORM	IDPS-109	—
C2-MIDR	Compressed-twice mosaicked image data record	IDPS-109	—
C2-MIDRW	Compressed-twice mosaicked image data record WORM	IDPS-109	—
C3-MIDR	Compressed-thrice mosaicked image data record	IDPS-109	—
C3-MIDRW	Compressed-thrice mosaicked image data record WORM	IDPS-109	2/17/88, 1/16/91, 10/2/91
EPHEMDR	Ephemeris data record	—	—
F-BIDR	Full-resolution basic image data record	SDPS-101	5/10/90, 2/14/91, 6/30/91, 10/18/91
F-BIDRW	Full-resolution basic image data record WORM	SDPS-101	—

Table 7.1. Magellan SIS Documents (Cont.).

ACRONYM	PRODUCT NAME	DOCUMENT NUMBER(S)	RELEASE DATE(S)
F-MAPDRCD	Full-resolution map data record CD-ROM	—	—
F-MIDR	Full-resolution mosaicked image data record	IDPS-109	2/17/88, 1/16/91 10/2/91
F-MIDRW	Full-resolution mosaicked image data record WORM	IDPS-109	—
F-SBIDR	Full-resolution special basic image data record	SDPS-101	—
F-TBIDR	Full-resolution temporary basic image data record	SDPS-101	—
F-UBIDR	Full-resolution engineering test basic image data record	SDPS-101	—
F-XBIDR	Full-resolution expedited basic image data record	SDPS-101	—
GADR	Global altimeter data record	IDPS-135	2/14/90, 1/17/91
GADRW	Global altimeter data record WORM	IDPS-135	—
GEDR	Global emissivity data record	MIT-001	—
GEOIDR	Geoid map data record	SCI-GRAV-102, CNES-002	—
G-MAPDR	Global map data record	—	—
G-MAPDRCD	Global map data record CD-ROM	—	—
GRAVDR	Gravity data record	—	—
GRDR	Global radiometer data record	IDPS-124	2/14/90, 1/16/91
GREDR	Global reflectivity data record	MIT-001	—
GSDR	Global slope data record	MIT-001	—
GTDR	Global topography data record	MIT-001	—
GxDRCD	global <i>x</i> data record CD-ROM (<i>x</i> = altimeter, emissivity, radiometer, reflectivity, slope, or topography)	IDPS-147	2/7/92, 4/24/92
IDR	Intermediate data record	TPS-130	—
LOSAPDR	Line-of-sight acceleration profiles data record	SCI-GRAV-103	—
LTMAGCDR	Limb track maneuver and S-band AGC data record	—	—
MCFDR	Media calibration file data record	TRK-103	—
MIDRCD	Mosaicked image data record: CD composite	IDPS-145	7/3/91, 4/24/92
MSAWORM	MSA WORM disk	—	—
NCFDR	Navigation constants file data record	NAV-103	—
NPDR	Experimenters' notepad data record	—	—

Table 7.1. Magellan SIS Documents (Cont.).

ACRONYM	PRODUCT NAME	DOCUMENT NUMBER(S)	RELEASE DATE(S)
ODFDR	Orbit data file data record	TRK-101	—
ODR	DSN original data record	TPS-102	—
ODRVALDR	ODR validation data record	TLM-317	—
PIDR	Polar image data record	IDPS-107	9/14/88, 1/28/91
PIDRW	Polar image data record WORM	IDPS-107	—
P-MIDR	Polar mosaicked image data record	IDPS-142	—
P-MIDRW	North polar mosaicked data record WORM	IDPS-142	—
RADARCALDR	Radar calibration data record	—	—
RADR	Radio-science data record	—	—
RSODR	Radio-science original data record	—	—
RUSDR	Radar upload summary data record	—	—
SAFDR	SEGS archival file data record	—	—
SAR-EDR	SAR experiment data record	TPS-101	—
SAR-TEDR	SAR temporary experiment data record	TPS-101	—
SAR-XEDR	SAR expedited experiment data record	TPS-101	—
SCEDR	Spacecraft ephemeris data record	NAV-124	—
SCVDR	Surface characteristics vector data record	—	—
SFFDR	Small forces file data record	SES-121	—
SHDR	Spherical harmonics data record	SCI-GRAV-101, CNES-001	—
SOPDR	Skeleton orbit profile data record	MSDS-106	—
SPCFDR	Station polynomial coefficients file data record	NAV-110	—
SPEDR-N	Spacecraft planetary ephemeris data record—NAIF	NAV-135	—
SPEDR-S	Spacecraft planetary ephemeris data record—special	—	—
SPSDR	SAR Data-Processing Team—produced special data record	—	—
TAEDR	Temporary archive engineering data record	—	—
TOPODR	Topographic model data record	—	—
TPCFDR	Tie-point coefficient file data record	IDPS-143	—
TPMFDR	Timing and polar motion file data record	TRK-104	—
VPDR	Very Long Baseline Interferometry products data record	NAV-137	—

Table 7.2. Begin and End Latitudes for BDRs.

ORBIT RANGE	UPLOAD(S)	BEGIN/END LATITUDE (IMMEDIATE ORBITS), DEGREES	BEGIN/END LATITUDE (DELAYED ORBITS), DEGREES
376-403	M0258	89.0/-51.0	69.0/-71.0
404-558	M0262-M0279	89.0/-51.0	54.9/-79.0
559-661	M0283-M0293	90.0/-52.0	69.0/-71.5
662-676	M0297	89.0/-51.5	54.7/-79.2
787-1045	M0314-M0346	89.0/-52.0	54.5/-79.0
1046-1097	M0349-M0353	81.4/-19.0	52.0/-51.0
1098-1147	M0356-M0359	75.0/-42.4	52.0/-62.5
1148-1250	M0363-M1009	73.0/-42.0	52.0/-61.0
1251-1301	M1012-M1016	77.5/-40.0	54.5/-61.0
1302-1354	M1019-M1023	82.3/-40.5	54.5/-65.5
1355-1485	M1026-M1043	89.0/-51.5	55.4/-79.0
1486-1607	M1044-M1058	89.0/-52.0	54.8/-60.0
1608-1949	M1058-M1103	89.0/-52.0	55.0/-79.0
1950-2001	M1107-M1110	89.0/-42.0	89.0/-42.0
2002-2054	M1114-M1117	89.0/-34.0	89.0/-34.0
2055-2106	M1121-M1124	89.0/-14.0	89.0/-14.0
2107-2165	M1128-M1135	89.0/8.0	89.0/8.0
2166-2175	M1135	89.0/8.0	89.0/8.0
2176-2218	M1138	89.0/14.0	89.0/14.0
2219-2337	M1143-M1156	-44.0/-72.0	-68.0/-89.0
2366-2464	M1163-M1174	-37.0/-70.0	-65.0/-89.0
2465-2586	M1177-M1193B	52.0/-45.0	52.0/-45.0
2587-2642	M1193E-M1197	-20.0/-79.0	-41.0/-89.0
2643-2673	M1201	14.0/-89.0	14.0/-89.0
2674-2681	M1205	14.0/-80.0	14.0/-80.0
2682-2688	M1206	14.0/-89.0	14.0/-89.0
2689-2936	M1207-M1239	75.0/-67.0	42.0/-89.0
2937-2998	M1241-M1246	-18.0/-89.0	-18.0/-89.0
2999-3101	M1249-M1260	5.0/-90.0	5.0/-90.0
3102-3204	M1263-M1274	-2.0/-89.0	-2.0/-89.0
3205-3255	M1277-M1281	-5.5/-89.0	-5.5/-89.0
3256-3358	M1284-R1295	6.0/-80.0	6.0/-80.0
3359-3461	M1298-D1309	-4.0/-89.0	-4.0/-89.0
3462-3667	M1312-D1337	-20.0/-73.0	-49.0/-89.0
3668-3715	M1340-M1344	-4.0/-80.0	-4.0/-80.0
3716-3719	M1347B	57.0/-65.0	57.0/-65.0
3720-3770	M1347D-M1351	-4.0/-80.0	-4.0/-80.0
3771-3880	M1354-M2001	7.0/-79.0	7.0/-79.0

Table 7.3. BIDR File Structure.

FILE NAME	FILE IDENTIFICATION	NUMBER OF TRAILING BLANKS	FILE SEQUENCE NUMBER	DESCRIPTION
BIDR Header	'FILE_01'	10	'0001'	Summary BIDR volume information
File 2	'FILE_02'	10	'0002'	Orbit header
File 3	'FILE_03'	10	'0003'	EDR data quality summary
File 4	'FILE_04'	10	'0004'	Spacecraft ephemeris file (orbit description)
File 5	'FILE_05'	10	'0005'	SCLK/SCET conversion coefficients
File 6	'FILE_06'	10	'0006'	DSN monitor records
File 7	'FILE_07'	10	'0007'	Quaternion pointing coefficients
File 8	'FILE_08'	10	'0008'	Processing bandwidths
File 9	'FILE_09'	10	'0009'	Decommutation and decalibration data
File 10	'FILE_10'	10	'0010'	Engineering data
File 11	'FILE_11'	10	'0011'	Radar header records
File 12	'FILE_12'	10	'0012'	Per-orbit parameters
File 13	'FILE_13'	10	'0013'	Image data in oblique sinusoidal projection
File 14	'FILE_14'	10	'0014'	Processing parameters for oblique sinusoidal data
File 15	'FILE_15'	10	'0015'	Image data in sinusoidal projection
File 16	'FILE_16'	10	'0016'	Processing parameters for sinusoidal data
File 17	'FILE_17'	10	'0017'	Processed radiometer data
File 18	'FILE_18'	10	'0018'	Cold-sky calibration results
File 19	'FILE_19'	10	'0019'	Processing monitor results
BIDR Trailer	'FILE_20'	10	'0020'	Additional BIDR volume information

Table 7.4. Engineering F-MIDR Label Identifications.

F-MIDR	PRODUCT LABEL IDENTIFICATION
FMIDR.27S339;1	IPSP.34528-214;1
FMIDR.05S335;1	IPSP.34535-214;1
FMIDR.40S342;1	IPSP.34536-214;1
FMIDR.30N334;1	IPSP.33698-98;1
FMIDR.50S345;1	IPSP.34537-214;1
FMIDR.55N337;1	IPSP.34531-214;1
FMIDR.20N334;1	IPSP.34534-214;1
FMIDR.75N332;1	IPSP.34518-214;1

Table 7.5. CD-ROM File Structure.

FILE	CONTENTS
Top-level directory	
AAREADME.TXT	General text (from which this selection is taken).
MCUMCOMM.TXT	A cumulative listing of comments concerning all MIDR CD-ROMs published so far.
GEO.TAB	A table of Venus geologic features.
GEO.LBL	A PDS detached label that describes GEO.TAB.
VOLDESC.SFD	A description of the contents of this CD-ROM volume in a format readable by both humans and computers.
[INDEX]	A directory containing index files for searching specific MIDR or GxDR products.
MCUMDIR.TAB	A table listing all MIDR and GxDR products published so far, including the MIDRs on this CD-ROM.
MCUMDIR.LBL	A PDS detached label that describes MCUMDIR.TAB.
CONTENTS.TAB	A tabular listing of each MIDR frame on this disk, the directory in which it is located, and its extent in latitude and longitude. Also includes whether MIDR has had seam removal procedures applied.
CONTENTS.LBL	A PDS detached label that describes CONTENTS.TAB.
[LABEL]	A directory containing catalog information describing the major Magellan data products that will be submitted to PDS. This information can be used to gain a top-level understanding of the Magellan mission, radar experiment, processing, and data products.
CATALOG.LBL	PDS high-level experiment-description catalog information.
C1MIDRDS.LBL	PDS high-level data-set catalog information for C1-MIDR.
C2MIDRDS.LBL	PDS high-level data-set catalog information for C2-MIDR.

Table 7.5. CD-ROM File Structure (Cont.).

FILE	CONTENTS
 - C3MIDRDS.LBL 	PDS high-level data-set catalog information for C3-MIDR.
 - FBIDRDS.LBL 	PDS high-level data-set catalog information for F-BIDR. The F-BIDR is the basic image data product. This file provides the information on how to extract radar backscatter cross-sections from MIDRs, given the incidence angle information from GEOM.TAB and the image data.
 - FMIDRDS.LBL 	PDS high-level data-set catalog information for F-MIDR.
 - xPMIDRDS.LBL 	PDS high-level data-set catalog information for P-MIDR, where x is N (north) or S (south).
 - DSMAPC1.LBL 	PDS high-level data-set catalog information describing C1-MIDR cartographic projections and references. This and following map projection files allow computation of latitude and longitude from image line and sample, using either the VICAR2 or PDS label information.
 - DSMAPC2.LBL 	PDS high-level data-set catalog information describing C2-MIDR cartographic projections and references.
 - DSMAPC3.LBL 	PDS high-level data-set catalog information describing C3-MIDR cartographic projections and references.
 - DSMAPP.LBL 	PDS high-level data-set catalog information describing P-MIDR cartographic projections and references.
 - DSMAPF.LBL 	PDS high-level data-set catalog information describing F-MIDR cartographic projections and references.
 - [x(y)nnzmmm] 	Directories containing framelets that make up a single 7168 line by 8192 sample mosaic, where x is either C (compressed mosaic) or F (full mosaic); y is either 1, 2, or 3 (C1-MIDR, C2-MIDR, or C3-MIDR, i.e., once, twice, or thrice compressed using 3-by-3 moving averages), or not present; nn is the middle latitude of the mosaic; z is N or S (north or south latitude); and mmm is the middle longitude of the mosaic. Both middle latitude and longitude have been rounded off to the nearest integer number.
 - BROWSE.IMG 	The browse version of the MIDR, 896 lines by 1024 samples, created by averaging groups of 8-by-8 pixels in the original MIDR.

Table 7.5. CD-ROM File Structure (Cont.).

FILE	CONTENTS
- BROWSE.LBL	A PDS detached label that describes BROWSE.IMG.
- FRAME.TAB	A table describing the range of latitude and longitude within each image framelet.
- FRAME.LBL	A PDS detached label that describes FRAME.TAB.
- GEOM.TAB	Selected entries from the Magellan Experimenters' Notebook. The Notebook is generated from the Magellan Radar Mapping Sequencing Software and is based on predicted information. Included in GEOM.TAB is information on orbit numbers for which data were acquired and used in the MIDR, together with information on radar viewing geometry and image quality.
- GEOM.LBL	A PDS detached label that describes GEOM.TAB.
- HIST.TAB	A binary histogram of pixel values in each 7168-by-8192 MIDR.
- HIST.LBL	A PDS detached label that describes HIST.TAB.
- x(y)Fnn.LBL	PDS detached labels describing the framelet files, where x is C (compressed mosaic) or F (full mosaic); y is 1, 2, or 3 (C1-MIDR, C2-MIDR, or C3-MIDR), or not present; and nn is the framelet number (01 through 56).
- x(y)Fnn.IMG	A 1024-by-1024 image framelet, where x, y, and nn are the same as in the preceding entry.

Table 7.6. Cycle-1 Cn-MIDRs by Compact Disk.

Cn-MIDR	COMPACT DISK IDENTIFICATION	Cn-MIDR	COMPACT DISK IDENTIFICATION	Cn-MIDR	COMPACT DISK IDENTIFICATION
00N009;1	MIDRCD.014	15N197;1	MIDRCD.033	30N189;1	MIDRCD.031
00N026;1	MIDRCD.012	15N215;1	MIDRCD.034	30N207;1	MIDRCD.033
00N026;2	MIDRCD.112	15N232;1	MIDRCD.037	30N225;1	MIDRCD.034
00N028;1	MIDRCD.037	15N249;1	MIDRCD.041	30N232;1	MIDRCD.043
00N060;1	MIDRCD.014	15N266;1	MIDRCD.041	30N243;1	MIDRCD.040
00N077;1	MIDRCD.016	15N283;1	MIDRCD.043	30N261;1	MIDRCD.040
00N080;1	MIDRCD.030	15N300;1	MIDRCD.047	30N279;1	MIDRCD.043
00N095;1	MIDRCD.019	15N317;1	MIDRCD.048	30N284;1	MIDRCD.051
00N095;2	MIDRCD.112	15N335;1	MIDRCD.002	30N284;2	MIDRCD.061
00N112;1	MIDRCD.019	15N335;2	MIDRCD.057	30N297;1	MIDRCD.047
00N112;2	MIDRCD.096	15N352;1	MIDRCD.002	30N315;1	MIDRCD.048
00N129;1	MIDRCD.019	15S009;1	MIDRCD.014	30N333;1	MIDRCD.002
00N131;1	MIDRCD.034	15S026;1	MIDRCD.012	30N333;2	MIDRCD.057
00N146;1	MIDRCD.022	15S026;2	MIDRCD.097	30N335;2	MIDRCD.051
00N163;1	MIDRCD.031	15S060;1	MIDRCD.016	30N351;1	MIDRCD.012
00N180;1	MIDRCD.030	15S077;1	MIDRCD.019	30S009;1	MIDRCD.014
00N183;1	MIDRCD.034	15S095;1	MIDRCD.019	30S026;1	MIDRCD.037
00N197;1	MIDRCD.033	15S095;2	MIDRCD.097	30S027;1	MIDRCD.014
00N215;1	MIDRCD.033	15S112;1	MIDRCD.020	30S027;2	MIDRCD.100
00N232;1	MIDRCD.034	15S112;2	MIDRCD.096	30S045;1	MIDRCD.037
00N234;1	MIDRCD.043	15S129;1	MIDRCD.019	30S063;1	MIDRCD.016
00N249;1	MIDRCD.040	15S146;1	MIDRCD.022	30S078;1	MIDRCD.037
00N266;1	MIDRCD.041	15S163;1	MIDRCD.030	30S081;1	MIDRCD.020
00N283;1	MIDRCD.043	15S180;1	MIDRCD.030	30S099;1	MIDRCD.020
00N286;1	MIDRCD.051	15S197;1	MIDRCD.033	30S099;2	MIDRCD.096
00N300;1	MIDRCD.047	15S215;1	MIDRCD.033	30S117;1	MIDRCD.021
00N317;1	MIDRCD.048	15S232;1	MIDRCD.034	30S117;2	MIDRCD.096
00N335;1	MIDRCD.002	15S249;1	MIDRCD.040	30S129;1	MIDRCD.037
00N337;2	MIDRCD.051	15S266;1	MIDRCD.041	30S135;1	MIDRCD.021
00N352;1	MIDRCD.002	15S283;1	MIDRCD.041	30S153;1	MIDRCD.022
14N060;1	MIDRCD.078	15S300;1	MIDRCD.047	30S171;1	MIDRCD.031
14N180;1	MIDRCD.069	15S317;1	MIDRCD.048	30S181;1	MIDRCD.037
14N300;1	MIDRCD.078	15S335;1	MIDRCD.002	30S189;1	MIDRCD.031
14S060;1	MIDRCD.078	15S352;1	MIDRCD.002	30S207;1	MIDRCD.033
14S180;1	MIDRCD.078	30N009;1	MIDRCD.012	30S225;1	MIDRCD.034
14S300;1	MIDRCD.078	30N026;1	MIDRCD.034	30S232;1	MIDRCD.043
15N009;1	MIDRCD.014	30N027;1	MIDRCD.012	30S243;1	MIDRCD.040
15N026;1	MIDRCD.012	30N027;2	MIDRCD.112	30S261;1	MIDRCD.040
15N026;2	MIDRCD.112	30N063;1	MIDRCD.016	30S279;1	MIDRCD.041
15N060;1	MIDRCD.016	30N078;1	MIDRCD.033	30S284;1	MIDRCD.051
15N077;1	MIDRCD.019	30N081;1	MIDRCD.020	30S297;1	MIDRCD.043
15N095;1	MIDRCD.019	30N099;1	MIDRCD.020	30S315;1	MIDRCD.047
15N095;2	MIDRCD.112	30N099;2	MIDRCD.097	30S333;1	MIDRCD.002
15N112;1	MIDRCD.020	30N117;1	MIDRCD.021	30S335;2	MIDRCD.126
15N112;2	MIDRCD.097	30N129;1	MIDRCD.034	30S351;1	MIDRCD.002
15N129;1	MIDRCD.020	30N135;1	MIDRCD.030	45N011;1	MIDRCD.014
15N146;1	MIDRCD.022	30N153;1	MIDRCD.022	45N032;1	MIDRCD.012
15N163;1	MIDRCD.031	30N171;1	MIDRCD.031	45N053;1	MIDRCD.016
15N180;1	MIDRCD.030	30N181;1	MIDRCD.043	45N074;1	MIDRCD.020

Table 7.6. Cycle-1 Cn-MIDRs by Compact Disk (Cont.).

Cn-MIDR	COMPACT DISK IDENTIFICATION	Cn-MIDR	COMPACT DISK IDENTIFICATION	Cn-MIDR	COMPACT DISK IDENTIFICATION
45N096;1	MIDRCD.020	45S286;1	MIDRCD.043	60S093;1	MIDRCD.054
45N096;2	MIDRCD.097	45S350;1	MIDRCD.002	60S097;1	MIDRCD.022
45N117;1	MIDRCD.021	60N014;1	MIDRCD.012	60S125;1	MIDRCD.022
45N117;2	MIDRCD.097	60N033;1	MIDRCD.043	60S153;1	MIDRCD.022
45N138;1	MIDRCD.021	60N033;2	MIDRCD.061	60S153;1	MIDRCD.054
45N159;1	MIDRCD.030	60N042;1	MIDRCD.016	60S180;1	MIDRCD.033
45N180;1	MIDRCD.030	60N070;1	MIDRCD.019	60S208;1	MIDRCD.034
45N202;1	MIDRCD.031	60N093;1	MIDRCD.051	60S213;1	MIDRCD.054
45N223;1	MIDRCD.037	60N097;1	MIDRCD.021	60S236;1	MIDRCD.037
45N244;1	MIDRCD.040	60N097;2	MIDRCD.097	60S263;1	MIDRCD.041
45N265;1	MIDRCD.041	60N125;1	MIDRCD.021	60S273;1	MIDRCD.054
45N286;1	MIDRCD.047	60N153;1	MIDRCD.031	60S291;1	MIDRCD.047
45N307;1	MIDRCD.047	60N153;1	MIDRCD.051	60S333;1	MIDRCD.069
45N329;1	MIDRCD.047	60N153;2	MIDRCD.061	60S347;1	MIDRCD.031
45N329;2	MIDRCD.060	60N180;1	MIDRCD.030	75N029;1	MIDRCD.016
45N350;1	MIDRCD.012	60N208;1	MIDRCD.037	75N029;2	MIDRCD.069
45S011;1	MIDRCD.012	60N213;1	MIDRCD.054	75N074;1	MIDRCD.022
45S032;1	MIDRCD.014	60N236;1	MIDRCD.040	75N119;1	MIDRCD.030
45S032;2	MIDRCD.112	60N263;1	MIDRCD.041	75N164;1	MIDRCD.037
45S074;1	MIDRCD.016	60N273;2	MIDRCD.061	75N209;1	MIDRCD.041
45S096;1	MIDRCD.019	60N291;1	MIDRCD.047	75N254;1	MIDRCD.048
45S096;2	MIDRCD.097	60N319;1	MIDRCD.048	75N299;1	MIDRCD.048
45S117;1	MIDRCD.021	60N333;1	MIDRCD.051	75N338;1	MIDRCD.014
45S117;2	MIDRCD.096	60N347;1	MIDRCD.014	75N338;2	MIDRCD.069
45S138;1	MIDRCD.021	60N347;2	MIDRCD.054	75S023;1	MIDRCD.054
45S159;1	MIDRCD.022	60S014;1	MIDRCD.016	75S068;1	MIDRCD.051
45S180;1	MIDRCD.069	60S033;1	MIDRCD.054	75S113;1	MIDRCD.051
45S202;1	MIDRCD.031	60S042;1	MIDRCD.020	75S203;1	MIDRCD.048
45S223;1	MIDRCD.033	60S042;2	MIDRCD.054	75S248;1	MIDRCD.048
45S244;1	MIDRCD.040	60S042;3	MIDRCD.097	75S293;1	MIDRCD.048
45S265;1	MIDRCD.040	60S070;1	MIDRCD.021	75S338;2	MIDRCD.078

Table 7.7. Cycle-1 F-MIDRs by Compact Disk.

F-MIDR	COMPACT DISK IDENTIFICATION	F-MIDR	COMPACT DISK IDENTIFICATION	F-MIDR	COMPACT DISK IDENTIFICATION
00N059;1	MIDRCD.059	00N189;1	MIDRCD.024	05N070;1	MIDRCD.009
00N065;1	MIDRCD.009	00N194;1	MIDRCD.024	05N076;1	MIDRCD.008
00N070;1	MIDRCD.009	00N200;1	MIDRCD.025	05N082;1	MIDRCD.010
00N076;1	MIDRCD.009	00N205;1	MIDRCD.027	05N087;1	MIDRCD.015
00N082;1	MIDRCD.010	00N217;1	MIDRCD.027	05N093;1	MIDRCD.120
00N087;1	MIDRCD.010	00N279;1	MIDRCD.046	05N098;1	MIDRCD.015
00N093;1	MIDRCD.120	00N284;1	MIDRCD.049	05N132;1	MIDRCD.017
00N104;1	MIDRCD.104	00N290;1	MIDRCD.093	05N177;1	MIDRCD.023
00N132;1	MIDRCD.017	00N318;1	MIDRCD.093	05N183;1	MIDRCD.077
00N138;1	MIDRCD.124	00N357;1	MIDRCD.005	05N188;1	MIDRCD.024
00N149;1	MIDRCD.111	05N020;1	MIDRCD.110	05N194;1	MIDRCD.024
00N155;1	MIDRCD.111	05N065;1	MIDRCD.009	05N200;1	MIDRCD.025

Table 7.7. Cycle-1 F-MIDRs by Compact Disk (Cont.).

F-MIDR	COMPACT DISK IDENTIFICATION	F-MIDR	COMPACT DISK IDENTIFICATION	F-MIDR	COMPACT DISK IDENTIFICATION
05N205;1	MIDRCD.027	10N188;1	MIDRCD.025	15N197;1	MIDRCD.025
05N217;1	MIDRCD.029	10N194;1	MIDRCD.024	15N203;1	MIDRCD.035
05N228;1	MIDRCD.032	10N200;1	MIDRCD.025	15N220;1	MIDRCD.066
05N239;1	MIDRCD.036	10N205;1	MIDRCD.032	15N237;1	MIDRCD.035
05N273;1	MIDRCD.045	10N211;1	MIDRCD.029	15N249;1	MIDRCD.036
05N284;1	MIDRCD.045	10N217;1	MIDRCD.032	15N260;1	MIDRCD.036
05N290;1	MIDRCD.046	10N228;1	MIDRCD.038	15N266;1	MIDRCD.045
05N301;1	MIDRCD.052	10N234;1	MIDRCD.032	15N283;1	MIDRCD.093
05N307;1	MIDRCD.053	10N267;1	MIDRCD.045	15N312;1	MIDRCD.053
05N318;1	MIDRCD.053	10N273;1	MIDRCD.045	15N340;1	MIDRCD.003
05N357;1	MIDRCD.005	10N279;1	MIDRCD.049	15S020;1	MIDRCD.105
05S059;1	MIDRCD.059	10N284;1	MIDRCD.045	15S077;1	MIDRCD.066
05S065;1	MIDRCD.010	10N290;1	MIDRCD.059	15S094;1	MIDRCD.120
05S070;1	MIDRCD.009	10N301;1	MIDRCD.093	15S106;1	MIDRCD.104
05S076;1	MIDRCD.009	10N307;1	MIDRCD.052	15S123;1	MIDRCD.018
05S082;1	MIDRCD.008	10S031;1	MIDRCD.106	15S129;1	MIDRCD.094
05S087;1	MIDRCD.010	10S059;1	MIDRCD.059	15S134;1	MIDRCD.094
05S098;1	MIDRCD.015	10S065;1	MIDRCD.010	15S140;1	MIDRCD.093
05S104;1	MIDRCD.104	10S070;1	MIDRCD.009	15S146;1	MIDRCD.122
05S132;1	MIDRCD.015	10S076;1	MIDRCD.009	15S152;1	MIDRCD.125
05S149;1	MIDRCD.111	10S082;1	MIDRCD.009	15S157;1	MIDRCD.023
05S155;1	MIDRCD.093	10S087;1	MIDRCD.010	15S163;1	MIDRCD.023
05S155;2	MIDRCD.107	10S093;1	MIDRCD.080	15S169;1	MIDRCD.065
05S177;1	MIDRCD.024	10S098;1	MIDRCD.015	15S174;1	MIDRCD.068
05S183;1	MIDRCD.026	10S104;1	MIDRCD.104	15S180;1	MIDRCD.025
05S189;1	MIDRCD.093	10S132;1	MIDRCD.015	15S214;1	MIDRCD.029
05S205;1	MIDRCD.028	10S144;1	MIDRCD.120	15S220;1	MIDRCD.067
05S211;1	MIDRCD.029	10S155;1	MIDRCD.023	15S226;1	MIDRCD.067
05S217;1	MIDRCD.028	10S177;1	MIDRCD.024	15S237;1	MIDRCD.035
05S222;1	MIDRCD.032	10S183;1	MIDRCD.026	15S243;1	MIDRCD.038
05S239;1	MIDRCD.035	10S188;1	MIDRCD.025	15S249;1	MIDRCD.038
05S250;1	MIDRCD.036	10S200;1	MIDRCD.027	15S254;1	MIDRCD.038
05S279;1	MIDRCD.046	10S211;1	MIDRCD.029	15S260;1	MIDRCD.038
05S284;1	MIDRCD.070	10S245;1	MIDRCD.039	15S277;1	MIDRCD.070
05S290;1	MIDRCD.070	10S250;1	MIDRCD.039	15S283;1	MIDRCD.046
05S295;1	MIDRCD.050	10S267;1	MIDRCD.036	15S289;1	MIDRCD.046
05S312;1	MIDRCD.059	10S273;1	MIDRCD.045	20N003;1	MIDRCD.007
05S357;1	MIDRCD.005	10S279;1	MIDRCD.070	20N080;1	MIDRCD.015
10N014;1	MIDRCD.010	10S284;1	MIDRCD.046	20N097;1	MIDRCD.015
10N020;1	MIDRCD.008	10S290;1	MIDRCD.046	20N145;1	MIDRCD.017
10N065;1	MIDRCD.013	10S301;1	MIDRCD.050	20N174;1	MIDRCD.062
10N076;1	MIDRCD.066	10S307;1	MIDRCD.052	20N186;1	MIDRCD.025
10N082;1	MIDRCD.120	15N014;1	MIDRCD.011	20N192;1	MIDRCD.024
10N093;1	MIDRCD.120	15N020;1	MIDRCD.011	20N198;1	MIDRCD.025
10N098;1	MIDRCD.017	15N111;1	MIDRCD.013	20N204;1	MIDRCD.028
10N132;1	MIDRCD.017	15N129;1	MIDRCD.015	20N227;1	MIDRCD.032
10N166;1	MIDRCD.065	15N169;1	MIDRCD.065	20N233;1	MIDRCD.036
10N172;1	MIDRCD.065	15N174;1	MIDRCD.065	20N239;1	MIDRCD.035
10N177;1	MIDRCD.024	15N186;1	MIDRCD.032	20N269;1	MIDRCD.044
10N183;1	MIDRCD.077	15N191;1	MIDRCD.025	20N275;1	MIDRCD.093

Table 7.7. Cycle-1 F-MIDRs by Compact Disk (Cont.).

F-MIDR	COMPACT DISK IDENTIFICATION	F-MIDR	COMPACT DISK IDENTIFICATION	F-MIDR	COMPACT DISK IDENTIFICATION
20N280;1	MIDRCD.046	25S003;1	MIDRCD.006	30S268;1	MIDRCD.042
20N286;1	MIDRCD.046	25S009;1	MIDRCD.007	30S275;1	MIDRCD.045
20N292;1	MIDRCD.044	25S034;1	MIDRCD.105	30S287;1	MIDRCD.094
20N328;1	MIDRCD.053	25S082;1	MIDRCD.013	30S357;1	MIDRCD.005
20N351;1	MIDRCD.004	25S095;1	MIDRCD.125	35N077;1	MIDRCD.011
20N357;1	MIDRCD.005	25S101;1	MIDRCD.110	35N083;1	MIDRCD.119
20S003;1	MIDRCD.006	25S131;1	MIDRCD.013	35N090;1	MIDRCD.108
20S033;1	MIDRCD.105	25S137;1	MIDRCD.094	35N150;1	MIDRCD.106
20S103;1	MIDRCD.108	25S156;1	MIDRCD.023	35N157;1	MIDRCD.080
20S121;1	MIDRCD.017	25S162;1	MIDRCD.023	35N163;1	MIDRCD.065
20S127;1	MIDRCD.080	25S168;1	MIDRCD.071	35N170;1	MIDRCD.103
20S139;1	MIDRCD.094	25S174;1	MIDRCD.071	35N197;1	MIDRCD.027
20S145;1	MIDRCD.018	25S192;1	MIDRCD.074	35N210;1	MIDRCD.080
20S156;1	MIDRCD.023	25S198;1	MIDRCD.071	35N230;1	MIDRCD.035
20S162;1	MIDRCD.024	25S247;1	MIDRCD.039	35N270;1	MIDRCD.044
20S168;1	MIDRCD.070	25S253;1	MIDRCD.042	35N277;1	MIDRCD.044
20S174;1	MIDRCD.065	25S259;1	MIDRCD.042	35N283;1	MIDRCD.044
20S180;1	MIDRCD.026	25S296;1	MIDRCD.050	35N290;1	MIDRCD.036
20S204;1	MIDRCD.029	25S302;1	MIDRCD.052	35N297;1	MIDRCD.050
20S210;1	MIDRCD.029	25S345;1	MIDRCD.003	35N303;1	MIDRCD.063
20S221;1	MIDRCD.029	25S357;1	MIDRCD.005	35N330;1	MIDRCD.052
20S227;1	MIDRCD.067	30N066;1	MIDRCD.080	35S003;1	MIDRCD.006
20S233;1	MIDRCD.035	30N085;1	MIDRCD.111	35S083;1	MIDRCD.011
20S245;1	MIDRCD.039	30N123;1	MIDRCD.013	35S090;1	MIDRCD.011
20S251;1	MIDRCD.039	30N161;1	MIDRCD.065	35S130;1	MIDRCD.013
20S257;1	MIDRCD.038	30N167;1	MIDRCD.065	35S137;1	MIDRCD.077
20S280;1	MIDRCD.070	30N174;1	MIDRCD.065	35S143;1	MIDRCD.053
20S286;1	MIDRCD.039	30N237;1	MIDRCD.038	35S157;1	MIDRCD.076
20S357;1	MIDRCD.005	30N256;1	MIDRCD.038	35S163;1	MIDRCD.023
25N003;1	MIDRCD.007	30N262;1	MIDRCD.036	35S170;1	MIDRCD.076
25N028;1	MIDRCD.105	30N269;1	MIDRCD.044	35S203;1	MIDRCD.094
25N082;1	MIDRCD.120	30N275;1	MIDRCD.044	35S243;1	MIDRCD.035
25N089;1	MIDRCD.120	30N281;1	MIDRCD.042	35S250;1	MIDRCD.094
25N119;1	MIDRCD.017	30N287;1	MIDRCD.044	35S270;1	MIDRCD.067
25N143;1	MIDRCD.093	30N294;1	MIDRCD.050	35S277;1	MIDRCD.071
25N174;1	MIDRCD.064	30N300;1	MIDRCD.052	35S283;1	MIDRCD.071
25N186;1	MIDRCD.026	30S003;1	MIDRCD.006	35S290;1	MIDRCD.049
25N205;1	MIDRCD.070	30S009;1	MIDRCD.007	35S297;1	MIDRCD.124
25N211;1	MIDRCD.027	30S022;1	MIDRCD.010	35S357;1	MIDRCD.005
25N223;1	MIDRCD.032	30S085;1	MIDRCD.121	40N018;1	MIDRCD.007
25N229;1	MIDRCD.032	30S104;1	MIDRCD.105	40N025;1	MIDRCD.008
25N259;1	MIDRCD.070	30S129;1	MIDRCD.013	40N081;1	MIDRCD.103
25N272;1	MIDRCD.087	30S136;1	MIDRCD.015	40N088;1	MIDRCD.011
25N278;1	MIDRCD.050	30S142;1	MIDRCD.053	40N138;1	MIDRCD.124
25N284;1	MIDRCD.042	30S155;1	MIDRCD.107	40N159;1	MIDRCD.066
25N296;1	MIDRCD.050	30S161;1	MIDRCD.023	40N166;1	MIDRCD.103
25N333;1	MIDRCD.053	30S205;1	MIDRCD.026	40N194;1	MIDRCD.028
25N345;1	MIDRCD.004	30S212;1	MIDRCD.028	40N230;1	MIDRCD.035
25N351;1	MIDRCD.004	30S218;1	MIDRCD.071	40N244;1	MIDRCD.042
25N357;1	MIDRCD.006	30S262;1	MIDRCD.042	40N251;1	MIDRCD.044

Table 7.7. Cycle-1 F-MIDRs by Compact Disk (Cont.).

F-MIDR	COMPACT DISK IDENTIFICATION	F-MIDR	COMPACT DISK IDENTIFICATION	F-MIDR	COMPACT DISK IDENTIFICATION
40N272;1	MIDRCD.044	50N054;1	MIDRCD.013	60N164;1	MIDRCD.026
40N279;1	MIDRCD.045	50N147;1	MIDRCD.026	60N207;1	MIDRCD.028
40N286;1	MIDRCD.046	50N163;1	MIDRCD.066	60N270;1	MIDRCD.042
40N321;1	MIDRCD.052	50N172;1	MIDRCD.027	60N281;1	MIDRCD.045
40S004;1	MIDRCD.006	50N180;1	MIDRCD.066	60N302;1	MIDRCD.059
40S011;1	MIDRCD.080	50N197;1	MIDRCD.027	60N312;1	MIDRCD.050
40S074;1	MIDRCD.018	50N205;1	MIDRCD.028	60N323;1	MIDRCD.053
40S131;1	MIDRCD.018	50N247;1	MIDRCD.039	60N334;1	MIDRCD.003
40S138;1	MIDRCD.013	50N264;1	MIDRCD.042	60N344;1	MIDRCD.004
40S145;1	MIDRCD.018	50N297;1	MIDRCD.049	60N355;1	MIDRCD.006
40S166;1	MIDRCD.121	50N306;1	MIDRCD.052	60S005;1	MIDRCD.005
40S201;1	MIDRCD.067	50N356;1	MIDRCD.006	60S016;1	MIDRCD.008
40S208;1	MIDRCD.067	50S013;1	MIDRCD.018	60S164;1	MIDRCD.063
40S222;1	MIDRCD.029	50S021;1	MIDRCD.039	60S175;1	MIDRCD.077
40S230;1	MIDRCD.032	50S088;1	MIDRCD.011	60S185;1	MIDRCD.077
40S244;1	MIDRCD.035	50S147;1	MIDRCD.076	60S196;1	MIDRCD.070
40S272;1	MIDRCD.067	50S180;1	MIDRCD.076	60S207;1	MIDRCD.026
40S279;1	MIDRCD.049	50S188;1	MIDRCD.076	60S355;1	MIDRCD.003
40S286;1	MIDRCD.049	50S230;1	MIDRCD.070	65N006;1	MIDRCD.008
40S293;1	MIDRCD.071	50S272;1	MIDRCD.039	65N018;1	MIDRCD.007
40S300;1	MIDRCD.050	50S345;1	MIDRCD.003	65N102;1	MIDRCD.015
40S349;1	MIDRCD.004	50S356;1	MIDRCD.004	65N114;1	MIDRCD.017
45N004;1	MIDRCD.007	55N023;1	MIDRCD.008	65N126;1	MIDRCD.013
45N019;1	MIDRCD.011	55N060;1	MIDRCD.011	65N162;1	MIDRCD.026
45N080;1	MIDRCD.011	55N152;1	MIDRCD.023	65N186;1	MIDRCD.027
45N088;1	MIDRCD.070	55N171;1	MIDRCD.066	65N198;1	MIDRCD.028
45N119;1	MIDRCD.017	55N180;1	MIDRCD.066	65N294;1	MIDRCD.058
45N126;1	MIDRCD.017	55N208;1	MIDRCD.028	65N306;1	MIDRCD.056
45N157;1	MIDRCD.066	55N236;1	MIDRCD.036	65N318;1	MIDRCD.058
45N188;1	MIDRCD.066	55N263;1	MIDRCD.042	65N330;1	MIDRCD.003
45N195;1	MIDRCD.026	55N291;1	MIDRCD.049	65N342;1	MIDRCD.004
45N211;1	MIDRCD.027	55N319;1	MIDRCD.053	65N354;1	MIDRCD.006
45N241;2	MIDRCD.038	55N328;1	MIDRCD.052	65S005;2	MIDRCD.005
45N249;1	MIDRCD.039	55N337;1	MIDRCD.003	65S114;1	MIDRCD.067
45N295;1	MIDRCD.049	55N346;1	MIDRCD.004	65S186;1	MIDRCD.094
45S012;1	MIDRCD.080	55S014;1	MIDRCD.018	65S354;1	MIDRCD.003
45S019;1	MIDRCD.018	55S097;1	MIDRCD.077	70N007;1	MIDRCD.007
45S111;1	MIDRCD.098	55S171;1	MIDRCD.077	70N296;1	MIDRCD.049
45S142;1	MIDRCD.038	55S180;1	MIDRCD.077	70N310;1	MIDRCD.050
45S211;1	MIDRCD.028	55S199;1	MIDRCD.076	70N324;1	MIDRCD.052
45S218;1	MIDRCD.029	55S355;1	MIDRCD.004	70N339;1	MIDRCD.004
45S226;1	MIDRCD.076	60N005;1	MIDRCD.008	70N353;1	MIDRCD.006
45S234;1	MIDRCD.067	60N016;1	MIDRCD.007	75N237;1	MIDRCD.036
45S280;1	MIDRCD.049	60N026;1	MIDRCD.008	75N313;1	MIDRCD.056
45S349;1	MIDRCD.003	60N111;1	MIDRCD.018	75N332;1	MIDRCD.003
50N021;1	MIDRCD.008	60N132;1	MIDRCD.018	75N351;1	MIDRCD.007

Table 7.8. Cycle-2 Cn-MIDRs by Compact Disk.

Cn-MIDR	COMPACT DISK IDENTIFICATION	Cn-MIDR	COMPACT DISK IDENTIFICATION	Cn-MIDR	COMPACT DISK IDENTIFICATION
00N028;201	MIDRCD.083	15S146;201	MIDRCD.061	30S335;201	MIDRCD.082
00N028;201	MIDRCD.084	15S163;201	MIDRCD.090	30S335;202	MIDRCD.081
00N043;201	MIDRCD.057	15S180;201	MIDRCD.090	45N032;201	MIDRCD.054
00N060;201	MIDRCD.057	15S197;201	MIDRCD.090	45N053;201	MIDRCD.060
00N060;202	MIDRCD.060	15S215;201	MIDRCD.089	45N074;201	MIDRCD.126
00N077;201	MIDRCD.079	15S232;201	MIDRCD.079	45N096;201	MIDRCD.061
00N080;201	MIDRCD.084	15S283;201	MIDRCD.126	45N117;201	MIDRCD.079
00N080;202	MIDRCD.083	15S300;201	MIDRCD.089	45N329;201	MIDRCD.079
00N095;201	MIDRCD.089	15S317;201	MIDRCD.089	45S011;201	MIDRCD.060
00N112;201	MIDRCD.088	30N026;201	MIDRCD.126	45S032;201	MIDRCD.095
00N131;201	MIDRCD.081	30N027;201	MIDRCD.060	45S032;202	MIDRCD.092
00N146;201	MIDRCD.061	30N045;201	MIDRCD.057	45S053;201	MIDRCD.060
00N163;201	MIDRCD.089	30N078;201	MIDRCD.083	45S053;202	MIDRCD.061
00N180;201	MIDRCD.088	30N078;202	MIDRCD.084	45S074;201	MIDRCD.092
00N183;201	MIDRCD.081	30N081;201	MIDRCD.126	45S096;201	MIDRCD.092
00N197;201	MIDRCD.088	30N099;201	MIDRCD.061	45S117;201	MIDRCD.078
00N215;201	MIDRCD.088	30N117;201	MIDRCD.069	45S138;201	MIDRCD.092
00N234;201	MIDRCD.081	30N129;201	MIDRCD.083	45S159;201	MIDRCD.092
00N283;201	MIDRCD.088	30N333;201	MIDRCD.079	45S180;201	MIDRCD.092
00N286;201	MIDRCD.083	30N335;201	MIDRCD.126	45S202;201	MIDRCD.092
00N286;202	MIDRCD.084	30S026;201	MIDRCD.084	45S223;201	MIDRCD.078
00N300;201	MIDRCD.088	30S026;202	MIDRCD.081	45S244;201	MIDRCD.085
00N317;201	MIDRCD.088	30S045;201	MIDRCD.057	45S265;201	MIDRCD.091
00N337;201	MIDRCD.126	30S063;201	MIDRCD.069	45S286;201	MIDRCD.091
14N060;201	MIDRCD.085	30S063;202	MIDRCD.091	45S307;201	MIDRCD.091
14N060;202	MIDRCD.126	30S078;201	MIDRCD.084	45S329;201	MIDRCD.085
14N180;201	MIDRCD.126	30S078;202	MIDRCD.081	45S350;201	MIDRCD.060
14N300;201	MIDRCD.084	30S081;201	MIDRCD.091	60N033;201	MIDRCD.083
14S060;201	MIDRCD.084	30S099;201	MIDRCD.091	60N033;202	MIDRCD.084
14S300;202	MIDRCD.126	30S117;201	MIDRCD.079	60N070;201	MIDRCD.089
15N043;201	MIDRCD.057	30S129;201	MIDRCD.082	60N093;202	MIDRCD.083
15N060;201	MIDRCD.089	30S135;201	MIDRCD.079	60N097;201	MIDRCD.089
15N060;202	MIDRCD.092	30S153;201	MIDRCD.091	60N153;202	MIDRCD.082
15N077;201	MIDRCD.078	30S171;201	MIDRCD.091	60N333;201	MIDRCD.081
15N095;201	MIDRCD.089	30S181;201	MIDRCD.081	60N347;201	MIDRCD.069
15N112;201	MIDRCD.061	30S189;201	MIDRCD.091	60S014;202	MIDRCD.060
15N129;201	MIDRCD.069	30S207;201	MIDRCD.091	60S033;201	MIDRCD.082
15N335;201	MIDRCD.089	30S225;201	MIDRCD.079	60S033;202	MIDRCD.083
15S026;201	MIDRCD.090	30S232;201	MIDRCD.081	60S042;202	MIDRCD.057
15S043;201	MIDRCD.057	30S243;201	MIDRCD.090	60S070;201	MIDRCD.085
15S060;201	MIDRCD.057	30S261;201	MIDRCD.079	60S093;202	MIDRCD.082
15S060;202	MIDRCD.060	30S279;201	MIDRCD.090	60S097;201	MIDRCD.095
15S077;201	MIDRCD.078	30S284;201	MIDRCD.082	60S125;201	MIDRCD.095
15S095;201	MIDRCD.090	30S284;202	MIDRCD.081	60S153;201	MIDRCD.082
15S112;201	MIDRCD.079	30S297;201	MIDRCD.090	60S153;201	MIDRCD.095
15S129;201	MIDRCD.069	30S315;201	MIDRCD.090	60S208;201	MIDRCD.095

Table 7.8. Cycle-2 Cn-MIDRs by Compact Disk (Cont.).

Cn-MIDR	COMPACT DISK IDENTIFICATION	Cn-MIDR	COMPACT DISK IDENTIFICATION	Cn-MIDR	COMPACT DISK IDENTIFICATION
60S213;202	MIDRCD.082	60S333;201	MIDRCD.082	75S158;201	MIDRCD.096
60S236;201	MIDRCD.095	60S333;202	MIDRCD.083	75S203;201	MIDRCD.084
60S263;201	MIDRCD.085	60S347;201	MIDRCD.060	75S248;201	MIDRCD.085
60S273;201	MIDRCD.082	75N074;201	MIDRCD.069	75S293;201	MIDRCD.085
60S273;202	MIDRCD.083	75S023;201	MIDRCD.085	75S338;201	MIDRCD.095
60S291;201	MIDRCD.095	75S068;201	MIDRCD.096	75S338;202	MIDRCD.097
60S319;201	MIDRCD.092	75S113;201	MIDRCD.085		

Table 7.9. Cycle-2 F-MIDRs by Compact Disk.

F-MIDR	COMPACT DISK IDENTIFICATION	F-MIDR	COMPACT DISK IDENTIFICATION	F-MIDR	COMPACT DISK IDENTIFICATION
00N037;201	MIDRCD.055	10N076;201	MIDRCD.080	25N046;201	MIDRCD.055
00N042;201	MIDRCD.055	10S054;201	MIDRCD.056	25N052;201	MIDRCD.062
00N048;201	MIDRCD.058	10S087;201	MIDRCD.072	25N119;201	MIDRCD.068
00N054;201	MIDRCD.062	10S115;201	MIDRCD.068	25N333;201	MIDRCD.058
00N070;201	MIDRCD.072	10S177;201	MIDRCD.072	25S131;201	MIDRCD.068
00N115;201	MIDRCD.064	10S183;201	MIDRCD.072	25S168;201	MIDRCD.074
00N149;201	MIDRCD.110	15N037;201	MIDRCD.056	25S168;202	MIDRCD.107
00N155;201	MIDRCD.119	15N043;201	MIDRCD.055	25S174;201	MIDRCD.074
00N189;201	MIDRCD.064	15N049;201	MIDRCD.055	25S198;201	MIDRCD.074
00N194;201	MIDRCD.064	15N054;201	MIDRCD.062	25S198;202	MIDRCD.123
00N200;201	MIDRCD.072	15N112;201	MIDRCD.063	30N035;201	MIDRCD.056
05N048;201	MIDRCD.055	15S049;201	MIDRCD.053	30N041;201	MIDRCD.056
05N054;201	MIDRCD.062	15S054;201	MIDRCD.058	30N047;201	MIDRCD.055
05N087;201	MIDRCD.111	15S060;201	MIDRCD.073	30N054;201	MIDRCD.063
05N115;201	MIDRCD.067	15S077;202	MIDRCD.103	30S041;201	MIDRCD.058
05N194;201	MIDRCD.064	15S112;201	MIDRCD.064	30S098;201	MIDRCD.064
05N200;201	MIDRCD.072	15S117;201	MIDRCD.063	30S142;201	MIDRCD.063
05S031;201	MIDRCD.059	15S157;201	MIDRCD.073	30S142;202	MIDRCD.068
05S037;201	MIDRCD.055	15S163;201	MIDRCD.064	30S205;201	MIDRCD.074
05S042;201	MIDRCD.055	15S169;201	MIDRCD.073	30S218;201	MIDRCD.074
05S054;201	MIDRCD.062	15S174;201	MIDRCD.073	35N050;201	MIDRCD.062
05S087;201	MIDRCD.072	15S180;201	MIDRCD.073	35N077;201	MIDRCD.080
05S093;201	MIDRCD.072	15S214;201	MIDRCD.073	35S043;201	MIDRCD.074
05S093;202	MIDRCD.102	20N038;201	MIDRCD.056	35S137;201	MIDRCD.063
05S099;201	MIDRCD.072	20N044;201	MIDRCD.058	35S143;201	MIDRCD.063
05S099;202	MIDRCD.108	20N050;201	MIDRCD.056	35S143;202	MIDRCD.068
05S115;201	MIDRCD.064	20N080;201	MIDRCD.087	40N046;201	MIDRCD.056
05S149;201	MIDRCD.105	20N080;202	MIDRCD.098	40N053;201	MIDRCD.062
05S155;201	MIDRCD.108	20N334;201	MIDRCD.056	40N088;201	MIDRCD.072
05S205;201	MIDRCD.068	20S109;201	MIDRCD.074	40S138;201	MIDRCD.063
05S205;202	MIDRCD.119	20S162;201	MIDRCD.064	40S145;201	MIDRCD.068
10N031;201	MIDRCD.058	20S168;201	MIDRCD.074	45N081;201	MIDRCD.071
10N042;201	MIDRCD.058	20S174;201	MIDRCD.073	45N088;201	MIDRCD.071
10N048;201	MIDRCD.055	20S180;201	MIDRCD.073	45S019;201	MIDRCD.075
10N054;201	MIDRCD.062	20S221;201	MIDRCD.073	45S211;201	MIDRCD.075
10N065;201	MIDRCD.059	20S227;201	MIDRCD.073	45S218;201	MIDRCD.068

Table 7.9. Cycle-2 F-MIDRs by Compact Disk (Cont.).

F-MIDR	COMPACT DISK IDENTIFICATION	F-MIDR	COMPACT DISK IDENTIFICATION	F-MIDR	COMPACT DISK IDENTIFICATION
45S226;201	MIDRCD.098	55N337;201	MIDRCD.058	60S175;201	MIDRCD.094
45S234;201	MIDRCD.074	55S014;201	MIDRCD.075	60S185;201	MIDRCD.076
45S234;202	MIDRCD.121	55S097;201	MIDRCD.094	60S196;201	MIDRCD.075
45S349;201	MIDRCD.062	55S097;202	MIDRCD.106	60S207;201	MIDRCD.075
50S013;201	MIDRCD.080	55S199;201	MIDRCD.075	65N102;201	MIDRCD.068
50S021;201	MIDRCD.075	55S319;201	MIDRCD.075	65S006;201	MIDRCD.111
50S230;201	MIDRCD.075	55S328;201	MIDRCD.075	65S114;201	MIDRCD.076
50S230;202	MIDRCD.121	55S356;201	MIDRCD.063	65S186;201	MIDRCD.077
50S348;201	MIDRCD.059	60S016;201	MIDRCD.077		
50S356;201	MIDRCD.059	60S101;201	MIDRCD.076		

Table 7.10. Cycle-3 Cn-MIDRs by Compact Disk.

Cn-MIDR	COMPACT DISK IDENTIFICATION	Cn-MIDR	COMPACT DISK IDENTIFICATION	Cn-MIDR	COMPACT DISK IDENTIFICATION
00N009;301	MIDRCD.114	15S009;301	MIDRCD.115	30S153;301	MIDRCD.116
00N026;301	MIDRCD.114	15S026;301	MIDRCD.115	30S171;301	MIDRCD.099
00N028;301	MIDRCD.096	15S060;301	MIDRCD.113	30S181;301	MIDRCD.118
00N060;301	MIDRCD.113	15S077;301	MIDRCD.114	30S315;301	MIDRCD.100
00N077;301	MIDRCD.114	15S095;301	MIDRCD.117	30S333;301	MIDRCD.100
00N080;301	MIDRCD.092	15S112;301	MIDRCD.115	30S335;301	MIDRCD.119
00N095;301	MIDRCD.116	15S129;301	MIDRCD.099	45N032;301	MIDRCD.116
00N112;301	MIDRCD.085	15S146;301	MIDRCD.117	45N053;301	MIDRCD.116
00N129;301	MIDRCD.112	15S163;301	MIDRCD.117	45N074;301	MIDRCD.113
00N131;301	MIDRCD.118	15S180;301	MIDRCD.099	45N096;301	MIDRCD.114
00N146;301	MIDRCD.114	15S232;301	MIDRCD.113	45N138;301	MIDRCD.115
00N163;301	MIDRCD.116	15S317;301	MIDRCD.100	45N159;301	MIDRCD.099
00N180;301	MIDRCD.117	15S335;301	MIDRCD.100	45N180;301	MIDRCD.117
00N183;301	MIDRCD.118	30N009;301	MIDRCD.115	45N350;301	MIDRCD.088
00N317;301	MIDRCD.100	30N045;301	MIDRCD.113	45S053;301	MIDRCD.116
00N335;301	MIDRCD.100	30N063;301	MIDRCD.113	45S074;301	MIDRCD.096
00N373;302	MIDRCD.118	30N078;301	MIDRCD.119	45S096;301	MIDRCD.114
14N060;301	MIDRCD.119	30N081;301	MIDRCD.115	45S138;301	MIDRCD.117
14N160;301	MIDRCD.119	30N099;301	MIDRCD.114	45S159;301	MIDRCD.116
14N300;301	MIDRCD.119	30N135;301	MIDRCD.114	45S180;301	MIDRCD.099
15N009;301	MIDRCD.116	30N153;301	MIDRCD.116	45S244;301	MIDRCD.113
15N026;301	MIDRCD.115	30N171;301	MIDRCD.099	45S329;301	MIDRCD.099
15N043;301	MIDRCD.113	30N181;301	MIDRCD.112	60N014;301	MIDRCD.115
15N060;301	MIDRCD.114	30N335;301	MIDRCD.090	60N033;301	MIDRCD.118
15N077;301	MIDRCD.113	30N335;301	MIDRCD.118	60N042;301	MIDRCD.115
15N095;301	MIDRCD.115	30N335;302	MIDRCD.112	60N093;301	MIDRCD.118
15N129;301	MIDRCD.112	30N351;301	MIDRCD.088	60N153;301	MIDRCD.118
15N146;301	MIDRCD.116	30S063;301	MIDRCD.117	60N333;301	MIDRCD.118
15N163;301	MIDRCD.099	30S078;301	MIDRCD.096	60N347;301	MIDRCD.113
15N180;301	MIDRCD.099	30S081;301	MIDRCD.117	75N029;301	MIDRCD.100
15N317;301	MIDRCD.099	30S099;301	MIDRCD.117	75N344;301	MIDRCD.100
15N335;301	MIDRCD.100	30S129;301	MIDRCD.118		
15N352;301	MIDRCD.088	30S135;301	MIDRCD.117		

Table 7.11. Cycle-3 F-MIDRs by Compact Disk.

F-MIDR	COMPACT DISK IDENTIFICATION	F-MIDR	COMPACT DISK IDENTIFICATION	F-MIDR	COMPACT DISK IDENTIFICATION
00N159;301	MIDRCD.122	10S155;301	MIDRCD.109	25S327;301	MIDRCD.098
00N065;301	MIDRCD.087	10S177;301	MIDRCD.101	30N054;301	MIDRCD.121
00N070;301	MIDRCD.123	10S324;301	MIDRCD.098	30N085;301	MIDRCD.120
00N076;301	MIDRCD.124	15N014;301	MIDRCD.087	30N161;301	MIDRCD.106
00N082;301	MIDRCD.086	15N020;301	MIDRCD.086	30N167;301	MIDRCD.101
00N087;301	MIDRCD.124	15N037;301	MIDRCD.107	30S136;301	MIDRCD.110
00N093;301	MIDRCD.121	15N043;301	MIDRCD.086	30S142;301	MIDRCD.111
00N132;301	MIDRCD.108	15N049;301	MIDRCD.086	30S161;301	MIDRCD.109
00N138;301	MIDRCD.125	15N054;301	MIDRCD.122	30S325;301	MIDRCD.103
00N149;301	MIDRCD.106	15N169;301	MIDRCD.102	30S332;301	MIDRCD.103
00N155;301	MIDRCD.104	15N174;301	MIDRCD.101	35N077;301	MIDRCD.123
05N020;301	MIDRCD.121	15S094;301	MIDRCD.121	35N083;301	MIDRCD.123
05N065;301	MIDRCD.086	15S134;301	MIDRCD.108	35N090;301	MIDRCD.121
05N070;301	MIDRCD.123	15S140;301	MIDRCD.109	35N150;301	MIDRCD.120
05N082;301	MIDRCD.086	15S157;301	MIDRCD.102	35N157;301	MIDRCD.109
05N087;301	MIDRCD.106	15S163;301	MIDRCD.102	35N163;301	MIDRCD.102
05N093;301	MIDRCD.124	15S169;301	MIDRCD.102	35N170;301	MIDRCD.111
05N099;301	MIDRCD.104	15S174;301	MIDRCD.101	35S083;301	MIDRCD.122
05N132;301	MIDRCD.108	15S323;301	MIDRCD.098	35S090;301	MIDRCD.101
05N329;301	MIDRCD.103	15S329;301	MIDRCD.103	35S137;301	MIDRCD.104
05S059;301	MIDRCD.122	20N003;301	MIDRCD.087	35S143;301	MIDRCD.109
05S065;301	MIDRCD.123	20N003;302	MIDRCD.125	35S157;301	MIDRCD.105
05S070;301	MIDRCD.106	20N038;301	MIDRCD.122	35S163;301	MIDRCD.102
05S076;301	MIDRCD.123	20N044;301	MIDRCD.086	35S170;301	MIDRCD.102
05S082;301	MIDRCD.087	20N080;301	MIDRCD.125	35S323;301	MIDRCD.110
05S087;301	MIDRCD.124	20N097;301	MIDRCD.098	35S330;301	MIDRCD.103
05S093;301	MIDRCD.107	20N145;301	MIDRCD.109	40N088;301	MIDRCD.104
05S099;301	MIDRCD.105	20N351;301	MIDRCD.125	40N138;301	MIDRCD.093
05S132;301	MIDRCD.110	20N357;301	MIDRCD.087	40N159;301	MIDRCD.109
05S149;301	MIDRCD.119	20S139;301	MIDRCD.110	40N166;301	MIDRCD.119
05S155;301	MIDRCD.111	20S145;301	MIDRCD.109	40S074;301	MIDRCD.124
05S177;301	MIDRCD.101	20S156;301	MIDRCD.107	40S138;301	MIDRCD.108
10N014;301	MIDRCD.098	20S162;301	MIDRCD.106	40S145;301	MIDRCD.109
10N020;301	MIDRCD.086	20S168;301	MIDRCD.107	40S328;301	MIDRCD.103
10N065;301	MIDRCD.086	20S174;301	MIDRCD.101	40S321;301	MIDRCD.110
10N076;301	MIDRCD.107	20S322;301	MIDRCD.098	45S218;301	MIDRCD.068
10N082;301	MIDRCD.123	25N003;301	MIDRCD.087	45S234;301	MIDRCD.108
10N093;301	MIDRCD.121	25N003;302	MIDRCD.125	45S349;301	MIDRCD.062
10N132;301	MIDRCD.108	25N082;301	MIDRCD.123	50N356;301	MIDRCD.098
10N166;301	MIDRCD.102	25N089;301	MIDRCD.125	50S348;301	MIDRCD.059
10N172;301	MIDRCD.101	25N143;301	MIDRCD.109	50S356;301	MIDRCD.059
10S059;301	MIDRCD.122	25N345;301	MIDRCD.086	55N337;301	MIDRCD.058
10S065;301	MIDRCD.124	25N351;301	MIDRCD.107	55S356;301	MIDRCD.063
10S070;301	MIDRCD.106	25N357;301	MIDRCD.124	60N005;301	MIDRCD.122
10S076;301	MIDRCD.123	25S082;301	MIDRCD.111	60N026;301	MIDRCD.087
10S082;301	MIDRCD.087	25S137;301	MIDRCD.110	60N355;301	MIDRCD.105
10S087;301	MIDRCD.107	25S156;301	MIDRCD.105	65N102;301	MIDRCD.068
10S093;301	MIDRCD.125	25S162;301	MIDRCD.102	65N354;301	MIDRCD.106
10S099;301	MIDRCD.104	25S168;301	MIDRCD.101	70N353;301	MIDRCD.122
10S132;301	MIDRCD.104	25S174;301	MIDRCD.101	75N351;301	MIDRCD.122
10S144;301	MIDRCD.125	25S320;301	MIDRCD.110		

Table 7.12. Magellan Data Product List.

DATA PRODUCT	RECORDED MEDIUM	DESCRIPTION	ARCHIVE FACILITY
AEDR (Archive engineering data record)	Tape	All spacecraft engineering data. DSN Monitor data, data number-to-engineering-unit conversion tables, and decommutation maps. Note: this product is for archive purposes only.	PDS Imaging Node
ALT-EDR (Altimeter experiment data record)	Tape	Digital data recorded by the altimeter on board Magellan. This product includes altimeter data plus echo data, radiometer data, and ancillary data. Each ALT-EDR contains data from one Magellan orbit; seven ALT-EDRs are contained on each tape.	—
ANTL (Telecommunications antenna pattern listings)	Tape	X- and S-band antenna patterns generated from data collected during near-field test of the antenna.	—
APIOP (Annotated Public Information Office photographs)	Photographic print/negative	Images that have been released to the public.	—
ARCDR (Altimeter/radiometer composite data record)	CD-ROM	Altimeter and radiometer data in time sequence, orbit by orbit.	NSSDC
BADR (Basic altimeter data record)	Tape	A compilation of range measurements to the Venusian surface as well as terrain elevation measurements from each altimeter burst. Note: this product was produced in Cycle 1 only.	—
BOUGDR (Bouguer map data record)	Tape	Contains the digital data necessary to contour a Bouguer map on a plotting system.	PDS Geophysics Node; NSSDC
BRDR (Basic radiometer data record)	Tape	Contains brightness temperature and effective black-body source temperature information derived from the radiometer data samples. It also contains ancillary, engineering, calibration, and ephemeris data. Note: this product was produced in Cycle 1 only.	—
C-BIDR (Compressed basic image data record)	Tape	Contains all F-BIDR data compressed from 75-m pixel spacing to 225-m pixel spacing by averaging 3-by-3 arrays of F-BIDR pixels. Each C-BIDR contains data from one Magellan orbit; five C-BIDRs are contained on each tape.	—

Table 7.12. Magellan Data Product List (Cont.).

DATA PRODUCT	RECORDED MEDIUM	DESCRIPTION	ARCHIVE FACILITY
<i>C_n</i> -MIDR (Compressed < <i>n</i> times> resolution mosaicked image data record)	CD-ROM	Mosaicked images produced from C-BIDRs or from lower-order <i>C_n</i> -MIDRs by combining multiple orbits of C-BIDR data. Edge effects from the combination may or may not be removed. C1-MIDRs have 225-m pixels and cover 15° of latitude; C2-MIDRs, 675-m pixels and 45° of latitude; C3-MIDRs, 2025-m pixels and 80° of latitude.	—
<i>C_n</i> -MIDRP (Compressed < <i>n</i> times> resolution mosaicked image data record photoproduct)	Photographic print/negative	Photoproduct associated with <i>C_n</i> -MIDRs.	—
DSNCL (DSN controllers' logs)	Hardcopy	Log sheets describing details of each DSN pass with Magellan.	—
EPHEMDR (Ephemeris data record)	Tape	Navigation and ephemeris files associated with the radio-science experiment. Note: these products were collected during the radio-science experiments.	—
F-BIDR (Full-resolution basic image data record)	Tape	SAR image containing 75-m pixel spacing. Each tape contains one Magellan orbit of SAR data and its corresponding ancillary data.	NSSDC
F-MIDR (Full-resolution mosaicked image data record)	CD-ROM	Mosaicked images produced from F-BIDRs by combining multiple orbits of F-BIDR data. Edge effects from the combination may or may not be removed. Each F-MIDR covers 5° of latitude.	NSSDC
F-MIDRP (Full-resolution mosaicked image data record photoproduct)	Photographic print/negative	Photoproduct associated with F-MIDRs.	—
GADR (Global altimeter data record)	Tape	Global map of topographic and backscatter information derived from altimetry data. Note: this product was produced in Cycle 1 only.	—
GEOIDR (Geoid map data record)	Tape	Contains digital data necessary to contour a geoid map on a plotting system.	PDS Geophysics Node; NSSDC
GRDR (Global radiometer data record)	Tape	Contains BRDR data compiled into global maps of brightness temperatures with 10-km-pixel spacing. The data corresponding to each quarter of Venus are contained on separate tapes.	—
GRDRP (Global radiometer data record photoproduct)	Photographic print/negative	Photoproduct of the GRDRs.	—
GREDR (Global reflectivity data record)	CD-ROM	Contains resampled reflectivity data from the ARCDR. These products are sinusoidal equal-area map projections with 5-km-pixel spacing.	—

Table 7.12. Magellan Data Product List (Cont.)

DATA PRODUCT	RECORDED MEDIUM	DESCRIPTION	ARCHIVE FACILITY
GREDRP (Global reflectivity data record photoproduct)	Photographic print/negative	Photoproduct of the GREDRs.	—
GSDR (Global slope data record)	CD-ROM	Contains root-mean-square (rms) meter-scale roughness derived using the Hagfors, 1970, model of radar surface scattering.	—
GSDRP (Global slope data record photoproduct)	Photographic print/negative	Photoproduct of the GSDRs.	—
GTDR (Global topography data record)	CD-ROM	Contains topography data from the ARCDR. These products are sinusoidal equal-area map projections with 5-km-pixel spacing.	—
GTDRP (Global topography data record photoproduct)	Photographic print/negative	Photoproduct of the GTDRs.	—
LOSAPDR (Line-of-sight acceleration profiles data record)	Tape	Contains digital data of line-of-sight accelerations on an orbit-by-orbit basis. Note: this was a special data product in Cycle 2.	PDS Geophysics Node; NSSDC
LTMAGCDR (Limb track maneuver and S-band AGC data record)	Tape	Data to indicate the direction and orientation of the high-gain antenna boresight.	—
MCFDR (Media calibration file data record)	Tape	Contains corrections for the effects of transmission media on the Doppler data.	PDS Geophysics Node; JPL RPIF
MPL (Maneuver profile list)	Hardcopy	Delta-velocity maneuvers, timing, and associated information for midcourse and trim maneuvers.	PDS Geophysics Node; NAIF
NCFDR (Navigation constants file data record)	Tape	Contains the navigation constants file.	PDS Geophysics Node; NAIF
NPDR (Experimenters' notepad data record)	3.5-in. floppy disk	Scaled-down version of the Experimenters' Notebook containing a subsampling of the information supplied in the Notebook. The intent of this product is to supply pertinent spacecraft information to individuals who have no access to the Notebook.	—
ODFDR (Orbit data file data record)	Tape	Contains the DSN Doppler observables.	PDS Geophysics Node; NSSDC
PIDR (Polar image data record)	Tape	Contains full-resolution SAR image strips for the latitude range 80° to 90° N and 80° to 90° S. Each PIDR contains one orbit of polar SAR data; each tape contains 20 PIDRs.	—
P-MIDR (Polar mosaicked image data record)	CD-ROM	Mosaicked images covering the north and south poles.	—

Table 7.12. Magellan Data Product List (Cont.).

DATA PRODUCT	RECORDED MEDIUM	DESCRIPTION	ARCHIVE FACILITY
P-MIDRP (Polar mosaicked image data record photoproduct)	Photographic print/negative	Photoproduct of the P-MIDRs.	—
RADR (Radio-science data record)	Tape	Processed radio-science data, which were collected during the radio-science experiments.	NSSDC; ATMOS
RDR (Residuals data record)	Tape	Contains observations and residuals for requested time periods. Note: this was a special data product in Cycle 2.	—
RSODR (Radio-science original data record)	Tape	All raw Magellan radio-science data transmitted to Earth along with selected ancillary data regarding the DSN station configuration.	ATMOS
SAR-EDR (SAR experiment data record)	Tape	Complete, nonredundant set of SAR, altimetry, radiometry, and ancillary data. The recorded data associated with each SAR burst are synchronously packed into the SAR-EDR, along with spacecraft engineering, DSN configuration, ephemeris, and other ancillary data necessary for radar data processing.	—
SCVDR (Surface characteristics vector data record)	Tape	Contains sorted scattering function segments from altimetry and SAR analysis, electrical properties estimates from altimetry and SAR analysis, plus radiometer and confidence estimates (Tyler et al., 1992). Digital data represent averages over surface elements of approximately 20 by 20 km.	NSSDC
SFFDR (Small forces file data record)	Tape	Lists known forces other than gravitation acting on the spacecraft.	PDS Geophysics Node; NAIF
SHDR (Spherical harmonics data record)	Tape	Contains digital tabulation of the spherical harmonic coefficients estimated from the Doppler data. Note: this was a special data product in Cycle 2.	—
SPEDR-N (Spacecraft planetary ephemeris data record—NAIF)	Tape	Contains data equivalent to the SPEDR-S, but in a format compatible with the Navigation Ancillary Archive Files. Note: this product was deleted during Cycle 1.	—
SPEDR-S (Spacecraft planetary ephemeris data record—special)	Tape	Contains special data for geodetic control network including SAR, altimetry, and Doppler inputs. Note: this was a special product in Cycle 2.	NAIF; PDS Imaging Node
TPMFDR (Timing and polar motion file data record)	Tape	Contains the timing and polar motion files.	PDS Geophysics Node; NAIF

Ordering Products

*M*agellan data products can be ordered through a variety of sources (see Appendix 3). NSSDC, PDS, and RPIFs all have access to Magellan data products; however, NSSDC is the primary contact for ordering specific products. NSSDC can be reached as follows:

National Space Science Data Center (NSSDC)
Goddard Space Flight Center
Greenbelt, Maryland 20771

Tel: (301) 286-6695
E-mail: request@nssdc.gsfc.nasa.gov

NSSDC can also be reached by logging onto their computer. In order to log onto the NSSDC computer, telnet to *NSSDC.GSFC.NASA.GOV* (or 128.183.36.25) and give the user name *NSSDC*. You will then be connected to a menu system which allows you to use the master directory or to leave questions or product orders for the NSSDC staff. If this is the first time you have used the NSSDC NODIS system, you will be asked for information that will be added to a database of NSSDC users.

Besides offering Magellan data products, NSSDC also provides the following software to display digital images:

- IMDISP (IBM PC)
- Browser (Macintosh)
- Pixel Pusher (Macintosh)
- True Color (Macintosh)

MIDRs can be ordered in both digital and hardcopy versions. When ordering hardcopies, the label identification is all that is needed to fill a request. An exception to this rule exists when ordering the Engineering F-MIDRs (see Section 7).

When ordering digital versions of MIDRs, use the appropriate CD-ROM identification listed for that image in the tables in Section 7. Each CD-ROM contains 10 MIDR images which were determined when the disk was first produced.

Many additional Magellan products are available through other sources. Appendix 3 describes some of these sources and provides contact information.

This publication is available from PDS and NSSDC, and from the following:

NASA Center for AeroSpace Information
800 Elkridge Landing Rd.
Linthicum Heights, Maryland 21090-2934

Tel: (301) 621-0390
E-mail: help@sti.nasa.gov

Acronyms and Abbreviations

Note: For a complete listing of Magellan data product acronyms, see Table 7.12.

AEDR	archive engineering data record	GxDR	global x data record (x = altimeter, emissivity, radiometer, reflectivity, slope, or topography)
ALTA	altimeter antenna	HGA	high-gain antenna
ALT-EDR	altimeter experiment data record	HH	horizontally polarized transmit, horizontally polarized receive
ANSI	American National Standard	ISO	International Standards Organization
ARCDR	altimeter/radiometer composite data record	JPL	Jet Propulsion Laboratory
BIDR	basic image data record	MGA	medium-gain antenna
C-BIDR	compressed basic image data record	MHR	Magellan High-Rate Processor
CD	compact disk	MIDR	mosaicked image data record
CD-ROM	compact disk read-only memory	MIT	Massachusetts Institute of Technology
CDS	Command and Data Subsystem	NASA	National Aeronautics and Space Administration
Cn-MIDRs	compressed <n times> resolution mosaicked image data records, denoting compressed-once MIDRs (C1-MIDRs), compressed-twice MIDRs (C2-MIDRs), and compressed-thrice MIDRs (C3-MIDRs)	NSSDC	National Space Science Data Center
DLAP	desired look-angle profile	ODR	original data record
DMS-A or -B	data management subsystem—A or -B	OTM	orbit trim maneuver
DN	data number	PC	personal computer
DSN	Deep Space Network	PDS	Planetary Data System
DSS	deep space station	P-MIDR	polar mosaicked image data record
EDR	experiment data record	PRF	pulse repetition frequency
F-BIDR	full-resolution basic image data record	RAM	random access memory
FEM	forward equipment module	rms	root-mean-square
F-MIDR	full-resolution mosaicked image data record	RPIF	Regional Planetary Image Facility
FPU	floating-point unit	SAR	synthetic aperture radar
FTP	File Transfer Protocol	SAR-EDR	SAR experiment data record
GCR	Group Coding Recording (Method)	SDPS	SAR Data-Processing Subsystem
GADR	global altimeter data record	SEP	Sun-Earth-probe
GEDR	global emissivity data record	SIS	Software Interface Specification
GRDR	global radiometer data record	TSP	time since periapsis
GREDR	global reflectivity data record	VOI	Venus orbit insertion
GSDR	global slope data record	VV	vertically polarized transmit, vertically polarized receive
GTDR	global topography data record	XAR	extended attribute record

References

- Curlander, J., and McDonough, R., 1991. *Synthetic Aperture Radar: Systems and Signal Processing*, John Wiley and Sons, New York.
- Elachi, C., 1988. *Spaceborne Radar Remote Sensing: Applications and Techniques*, IEEE Press, New York.
- Giuli, D., 1986. "Polarization Diversity in Radars," *Proc. IEEE* 74, 245–269.
- Hagfors, T., 1970. "Remote Probing of the Moon by Infrared and Microwave Emissions and by Radar," *Radio Sci.* 5, 189–227.
- Hunten, D. M., Colin, L., Donahue, T. M., and Moroz, V. I., eds., 1983. *Venus*, University of Arizona, Tucson.
- Jet Propulsion Laboratory, 1991. *Planetary Data System Data Preparation Workbook*, JPL Internal Document D-7669.
- Johnson, W., 1991. "Magellan Imaging Radar Mission to Venus," *Proc. IEEE* 79, 6.
- Li, F., and Goldstein, R., 1990. "Studies of Multibaseline Spaceborne Interferometric Synthetic Aperture Radars," *IEEE Trans. Geosci. Rem. Sens.* 28, 1.
- Muhleman, D. O., 1964. "Radar Scattering from Venus and the Moon," *Astron. J.* 69, 34–41.
- Pettengill, G. H., Ford, P. G., and Chapman, B. D., 1988. "Venus: Surface Electromagnetic Properties," *J. Geophys. Res.* 93, B12, 14,881–14,892.
- Saunders, R. S., and Pettengill, G. H., 1991. "Magellan Mission Summary," *Science* 252, 247.
- Saunders, R. S., Spear, A. J., Allin, P. C., Austin, R. S., Berman, A. L., Chandler, R. C., Clark, J., de Charon, A. V., de Jong, E. M., Griffith, D. G., Gunn, J. M., Hensley, S., Johnson, W. T. K., Kirby, C. E., Leung, K. S., Lyons, D. T., Michaels, G. A., Miller, J., Morris, R. B., Morrison, A. D., Piereson, R. G., Scott, J. F., Shaffer, S. J., Slonski, J. P., Stofan, E. R., Thompson, T. W., and Wall, S. D., 1992. "Magellan Mission Summary," *J. Geophys. Res.* 97, E8. (See also articles in *J. Geophys. Res.* 97, E10.)
- Scott, C., Shaffer, S., and Nussbaum, H., 1993. "Magellan Recorder Data Recovery Algorithms," *Proc. Int. Telemetry Conf.*, Las Vegas, Nevada.
- Tyler, G. L., Simpson, R. A., Maurier, M. J., and Holmann, E., 1992. "Scattering Properties of the Venusian Surface: Preliminary Results from Magellan," *J. Geophys. Res.* 97, E8.
- Ulaby, F. T., Moore, R. K., and Fung, A. K., 1982. *Microwave Remote Sensing, Volume II: Radar Remote Sensing and Surface Scattering and Emission Theory*, Addison-Wesley, Massachusetts.
- Wall, S. D., 1989. "Venus Unveiled," *Astronomy* (April issue).
- Wall, S. D., and Ledbetter, K. W., 1992. *Design of Mission Operations Systems for Scientific Remote Sensing*, Taylor & Francis, London.
- Yewell, S., 1993. *The Magellan Data Product Information Handbook*, Jet Propulsion Laboratory Internal Document 630-512 (D-11020).

3

Magellan Resources Document

MGN 1630-114

**MAGELLAN
RESOURCES**

ACCESS TO MAGELLAN PROJECT
INFORMATION AND SCIENCE DATA

AUGUST 1992



JPL D-9934

MGN 1630-114

MAGELLAN RESOURCES

ACCESS TO MAGELLAN PROJECT
INFORMATION AND SCIENCE DATA

PREPARED BY

DAVID OKERSON

MAGELLAN PROJECT ENGINEER,
SCIENCE APPLICATIONS
INTERNATIONAL CORP.

AUGUST 1992

JPL D-9934

PRECEDING PAGE BLANK NOT FILMED

(Appendix) 69

PAGE 68 INTENTIONALLY BLANK



TABLE OF CONTENTS

How To Get Magellan Materials	1
Summary	1
Members of the Public	1
Educators	4
Members of the Press or Writers	5
Researchers	6
Products Available	8
On-Line Computer Access	9
Other Sources	10
NASA Teacher Resource Centers	11
NASA Education Division	11
NASA Teacher Resource Center Network	11
Teacher Resource Centers	11
Regional Teacher Resource Centers	11
Central Operation of Resources for Educators (CORE)	11
Other Specialized Resource Centers	12
TRCs/RTRCs	12
User Information	16
Using The Magellan CD-ROMS	19
Getting Started	19
What Are All These Files?	20
IBM-Type Personal Computers	20
Macintosh Computers	21
Try Before You Buy	21
For Further Help	22
Magellan Data Products Support Office	23
Appendix A – Regional Planetary Image Facilities	25
Appendix B – Planetary Data System Nodes	27

PRECEDING PAGE BLANK NOT FILMED

▶ HOW TO GET MAGELLAN MATERIALS

Summary

NASA's Magellan mission has mapped almost all of the planet Venus using a high-resolution radar instrument. Hundreds of photographs, more than 48 CD-ROMs, and many other Magellan materials are available through a number of different sources. This resource guide describes the most appropriate routes through which different products can be obtained by the public, educators, the press and writers, and researchers.

Although these descriptions specifically address Magellan products, the same sources also provide access to products from most of NASA's other missions. Choosing the most appropriate source will depend on the type of requesters, the product they want, and their location.

Members of the Public

Members of the public interested in information about the Magellan mission will find the following sources most useful. Those with particular interest in photographic or digital materials from Magellan may find the additional sources listed in the section for Researchers useful. A list of sources outside NASA with Magellan materials available to the public is included at the end of this document, as well as a list of on-line computer sources.

▶ **Jet Propulsion Laboratory**
4800 Oak Grove Drive
Pasadena, California 91109
(818) 354-4321

The Magellan mission is managed by NASA's Jet Propulsion Laboratory (JPL) in Pasadena, California. JPL supports several major sources through which Magellan materials can be obtained. The mail stop of each source should be added to JPL's general address.

▶ **Public Information Office**
Mail Stop 180-200
(818) 354-5011

The Public Information Office (PIO) can provide most available information about the Magellan mission. The office's primary responsibility is to provide Magellan materials to the working press. It maintains a list of recognized press to whom it sends advance

notice of Magellan press conferences. Official PIO materials released at press conferences are given to those members of the press who attend the conferences and are sent simultaneously to those on the list who do not attend. Additional materials shown at press conferences or otherwise released by the Magellan Project are also available if specifically requested. All Magellan images carry captions describing the area covered and the features of particular scientific interest.

The recognized press list is limited in size. Currently, the list is limited to organizations in the United States. In order to assist those not on the list, JPL has arranged for released materials to be available quickly through contractors.

All released Magellan images are available to anyone (both press and the public) at nominal cost through the JPL contractor listed below. The images are provided to the contractor simultaneously with their release, and are available in a variety of formats. The contractor maintains and sells to requestors a catalog of available images which is updated periodically. Contact:

Newell Color
221 North Westmoreland Avenue
Los Angeles, California 90064-4892
(213) 380-2980 ext 269
Facsimile: (213) 739-6984

Videotapes of released Magellan materials can be purchased at nominal cost from a second JPL contractor listed below. Copies can be produced in a variety of video formats and standards, including PAL and SECAM. A list of the titles, identifying numbers, and running times of current Magellan videos is noted below. Contact:

The Videotape Company

10523-45 Burbank Blvd.
North Hollywood, California 91601
(818) 985-1666, Facsimile: (818) 985-1013,
Att: David Rodgers

The current tapes are:

- AVC092-01 Ten minute "Magellan: Mapping the Planet Venus"; narrated
- AVC91-091 Four 2-3 minute computer-generated flyovers; music only
- AVC90-180 Earlier computer-generated flyovers; music only



Magellan Project Office

Mail Stop 230-201
(818) 393-0600

The Magellan Project Office can provide assistance with questions which none of the other sources listed in this document can answer. However, in order to allow the Project to conduct the important work of operating the spacecraft and processing the data, please treat this source as your last, rather than your first, alternative.

Suggestions of appropriate names for Venus features can be sent to the Project Office for possible nomination to the International Astronomical Union. Names should honor women who have been dead at least 3 years and been notable and worthy of the honor. Political or military figures of the 19th and 20th centuries are not permitted, nor are notable representatives of religious faiths.



NASA Headquarters

Washington, DC 20546
(202) 453-1000

NASA Headquarters in Washington can provide some Magellan materials, assist in answering questions, and help in locating sources. The specific address of each source should be added to the general NASA Headquarters address.



Public Affairs Office

Code S
(202) 453-1547

The Public Affairs Office (PAO) can provide some Magellan materials, including lithographed prints of some of the imagery, and can assist in answering questions.



**Public Services Division
Public Inquiry Coordinator**

Code PO
(202) 453-8315

The Public Services Division can assist with inquiries about the Magellan mission and direct them to the appropriate sources.



Publications

Code FEP
(202) 453-8332

The Publications office can provide printed materials on the Magellan mission.



Magellan Program Office

Code SL

(202) 453-1587

The Magellan Program Office can provide assistance with questions which none of the other sources listed in this document can answer. However, in order to allow the Program Office to conduct the important work of managing the Magellan program, please treat this source as your last, rather than your first, alternative.

A "Traveling Exhibit" of Magellan images, videotapes, and digital imagery is available for public display to libraries, museums, and other public groups through a NASA Headquarters contractor. Contact:

Science Applications International Corporation

400 Virginia Avenue, SW, Suite 810

Washington, DC 20024

(202) 479-0750, Facsimile (202) 479-0856

Educators

Educators interested in additional information about the Magellan mission will find the following sources most useful.

▶ **Teacher Resource Centers**

NASA's Education Division supports Teacher Resource Centers (TRCs) at each NASA Center, as well as a large number of Regional TRCs in cooperation with educational organizations around the country. It also supports a center for distribution of audiovisual materials, the Central Operation of Resources for Educators (CORE). A list of all the TRCs can be found on pages 14 to 17.

The TRC at NASA's Jet Propulsion Laboratory usually has a wider variety of planetary material than the other Teacher Resource Centers. It can be reached at:

Jet Propulsion Laboratory Teacher Resource Center

Mail Stop CS-530
4800 Oak Grove Drive
Pasadena, California 91109
(818) 354-6916, Facsimile: (818) 354-8080

TRCs provide teachers with access to NASA's materials, including Magellan materials. In general, visiting teachers can browse through the materials, and the center can assist in duplicating materials, including slides and videotapes, in their collection. (In particular, centers can copy videotapes onto a blank tape provided by the teacher.) TRCs can also respond to requests by mail or telephone.

TRCs should be the principal source for educators interested in teaching material or suggestions for approaches to using the Magellan materials. The TRCs should also be able to provide assistance to teachers in understanding and using the materials beyond the ability of the National Space Science Data Center. Each TRC should have some Magellan materials. Because of the logistical difficulties of distributing some of the materials, such as posters, the

JPL TRC usually has a wider selection of materials on planetary exploration than other TRCs.

▶ **NASA Headquarters**
Education Division
Educational Publications
Code FEP
Washington, DC 20546
(202) 453-8332

Requests for information about education programs based on the Magellan mission or for additional educational material to support teaching based on the Magellan mission can be answered by NASA's Education Division. In particular, the Educational Publications branch can provide a wide range of printed materials.

▶ **SPACELINK**

SPACELINK is an electronic information system for educators (a computer bulletin board) particularly oriented toward teachers interested in using NASA materials in their classes. It is operated by NASA's Marshall Space Flight Center in Alabama. SPACELINK can be reached by a telephone modem or through the Internet network. It contains a wide variety of information, as well as software and digital image files in the GIF format, which are suitable for classroom computer display. Contact:

telnet: spacelink.msfc.nasa.gov (192.149.89.61)
modem: (205) 895-0028

Members of the Press or Writers

Members of the Press or writers interested in additional information about the Magellan mission will find the following sources most useful. The first points of contact should be the Public Information Offices of the Jet Propulsion Laboratory or NASA Headquarters listed in the section above for the general public. In addition to the sources of images shown in the general public section, NASA maintains an image library particularly for the use of the Press and writers.

▶ **NASA Headquarters**
Photographic Library
Code PMD
Washington, DC 20546
(202) 453-8375

NASA Headquarters maintains a library of publicly released images from all NASA programs, including Magellan. Requests from the press or requests from publishers or authors preparing books for print can be provided without charge as 4x5 inch positive color or black and white transparencies. Requests for other formats or requests from other members of the public may be supplied at nominal cost. Visitors can browse through the collection to select images. Requests for assistance in obtaining images by mail or telephone can be supported to a limited extent.

Researchers

Researchers interested in additional information about the Magellan mission, access to imagery or data collected, or detailed catalog information will find the following sources most useful.

▶ **National Space Science Data Center**

Goddard Space Flight Center
Coordinated Request and User Support Office
Mail Code 933.4

Greenbelt, Maryland 20771
(301) 286-6695, Facsimile: (301) 286-4952

On-line Catalog: NSSDC::

or nssdc.gsfc.nasa.gov
(128.183.36.25)

Username: nssdc

E-mail: NSSDC::REQUEST

or request@nssdc.gsfc.nasa.gov

The National Space Science Data Center (NSSDC) at NASA's Goddard Space Flight Center is the principal archive and distribution center for all NASA missions. It has all of Magellan's standard mosaic image products that have been released by the Project in both photographic and digital form on CD-ROMs. It also has press-released images, videotapes, software with which to display the CD-ROM digital images, planning maps of Venus, a fact sheet, and documentation.

NSSDC's principal charter is to support data distribution to researchers. Requests from NASA centers, Federal, State, and local governments, and NASA-funded researchers are supplied without charge. Other requests are supplied at a nominal charge. NSSDC will consider waiving these charges for educational requests for a limited quantity of material if the requestor explains the need for such treatment.

NSSDC has the equipment necessary to supply special requests, such as large photographic enlargements. It has a limited staff able to assist with questions about the products or the identification of products showing a specific feature. It is not, however, able to support requests for extensive assistance either by researchers, the public, or teachers.

A general catalog showing the classes of materials available through NSSDC is available for on-line computer access. Requests for materials can be made through the on-line catalog, by electronic mail, or by telephone.

▶ **Regional Planetary Image Facilities**

NASA's Planetary Geology and Geophysics program supports a group of Regional Planetary Image Facilities (RPIFs) around the United States, as well as overseas. A list of these facilities is attached in Appendix A.

The RPIFs have a charter to support researchers in planetary science. In practice, they are open by appointment to members of the public. Each RPIF maintains a complete photographic library of NASA's lunar and planetary exploration, including Magellan materials. Visitors can browse through Magellan materials, including the CD-ROM digital imagery collection and videotapes. Although the RPIF cannot provide copies of this material, its manager can assist visitors in ordering the materials they have selected.

The RPIF at NASA's Jet Propulsion Laboratory may have the broadest collection of Magellan materials available most quickly. In practice, it is open by appointment on Monday, Wednesday, and Friday to both researchers and members of the public. The RPIF houses a complete image library of NASA's lunar and planetary missions, including Magellan. Visitors can browse through Magellan materials, including the CD-ROM digital imagery collection and videotapes.

Jet Propulsion Laboratory

Regional Planetary Image Facility

Mail Stop 202-101

4800 Oak Grove Drive

Pasadena, California 91109

(818) 354-3343

Facsimile: (818) 354-3437

► Planetary Data System

Jet Propulsion Laboratory
4800 Oak Grove Drive
Mail Stop 525-3610
Pasadena, California 91109
(818) 306-6130, Facsimile: (818) 306-6929
E-mail: JPLPDS::PDS_OPERATOR or
pds_operator@jplpds.jpl.nasa.gov
(137.79.104.100)

Researchers funded by NASA's Solar System Exploration Division can obtain Magellan materials through the Planetary Data System (PDS). PDS consists of a central on-line catalog at the Jet Propulsion Laboratory and a number of "nodes" located at research facilities with particular expertise in specific planetary research areas. The Geosciences Node at Washington University is particularly responsible for cataloging and supporting Magellan data. A list of the current Planetary Data System nodes for different research areas is attached in Appendix B.

PDS provides an on-line central catalog showing the general classes of Magellan material available, and allowing the user to identify specific digital and photographic products. Requests for materials can be made through this central catalog. The requests are typically fulfilled by forwarding the request to NSSDC. Contact PDS to request an account.

The Geosciences Node provides a much more detailed catalog of the Magellan materials. This node can be reached through the central PDS catalog or directly. The Geophysics Node also supports visiting researchers and provides image processing capabilities to use the digital imagery. Contact:

Planetary Data System, Geosciences Node
Earth and Planetary Remote Sensing Laboratory
Washington University, Campus Box 1169
One Brookings Drive
St. Louis, Missouri 63130-4899
(314) 935-5493, Facsimile: (314) 935-7361
E-mail: WURST::MGNSO or
mgns0@wurst.wustl.edu
(128.252.135.4)

The Washington University PDS Node provides a direct and knowledgeable source of assistance in using Magellan data through a Magellan Data Products Support Office. The purpose of the Support Office is to provide users with information about and assistance in getting Magellan data. Standard and special data products are supported, including digital products, photographs, slides, videotapes, and NASA Public Information Office (PIO) products. The Support Office serves NASA-sponsored scientists, other researchers and educators, and the general public.

The Support Office is staffed by researchers experienced in working with Magellan data products. The primary contact is Dr. Edward Guinness. The Office can answer questions such as what data products exist, where they can be obtained and at what cost, and how to read digital data products. The Office can provide the information necessary to complete an NSSDC order form and will help users place an order.

In general, a user is referred to NSSDC when the Support Office is certain that NSSDC has the product in question. The Support Office gives the user the phone number and/or electronic mail address of NSSDC, and helps the user determine exactly what to request. For a non-standard product, or when the Support Office is not certain that NSSDC has a product, the Office tries to locate information about the product and then calls the user back. It then does whatever it can to help the user obtain the product.

NSSDC personnel will refer a user to the Magellan Data Products Support Office in cases where they cannot help the user and know the Support Office can. If NSSDC is not sure the Support Office has the answer, it will work directly with the Support Office to find the information, and then get back to the user.

The Support Office does not:

- ❑ Fill orders for standard products from the Geosciences Node inventory when the orders can be filled by NSSDC. Exceptions are made in special cases, for example if NSSDC is temporarily out of stock and the Geosciences Node can easily provide the product.

-
- Provide users with accounts on Geosciences Node computers. The Office will help users obtain accounts on the Planetary Data System computer in order to use the Magellan Detailed-Level Catalog or other parts of the PDS Catalog.

► U.S. Geological Survey

The U.S. Geological Survey (USGS) has a program to produce maps of the planets based on the best available data from NASA and foreign missions, including Soviet missions. The Venus maps currently available from USGS are based on data from NASA's Pioneer Venus Orbiter and the Soviet Venera 15/16 missions. New maps will be produced and made available based on the Magellan data over the next several years. NASA-funded researchers can obtain maps directly by contacting:

Ms. Jody Swann
Planetary Data Facility
U.S. Geological Survey
2255 North Gemini Drive
Flagstaff, Arizona 86001-1698
(602) 556-7262, Facsimile: (602) 556-7090

All interested persons can obtain a listing of planetary maps from the same address. Those not funded by NASA can order maps by writing:

U.S. Geological Survey
Mail Stop 306
Branch of Distribution
Denver Federal Center
P.O. Box 25286
Denver, Colorado 80225

For more information, contact:

Earth Science Information Center
U.S. Geological Survey
507 National Center
Reston, Virginia 22092
(703) 860-6045

Products Available

The following Magellan materials are currently available:

- Fact sheet
- Photographic standard map mosaic images
- CD-ROMs (standard map mosaic images in digital form)
- Software with which to use the CD-ROMs
- Released (press release) images
- Digital images available over computer networks
- Videotapes
- Venus maps
- Magellan Mapping Mission Planning Chart
- 35 mm slide set (20 slides)
- Lithographed prints of images
- Magellan spacecraft paper model
- Poster on Venus volcanism
- Traveling Exhibit

On-Line Computer Access

In addition to the on-line computer catalogs provided by NSSDC and PDS described above, Magellan information and digital imagery can be obtained through several computer networks.

SPACELINK is an electronic information system for educators (a computer bulletin board) particularly oriented toward teachers interested in using NASA materials in their classes. It is operated by NASA's Marshall Space Flight Center in Alabama. SPACELINK can be reached by a telephone modem or through the Internet network. It contains a wide variety of information, as well as software and digital image files in the GIF format, which are suitable for classroom computer display. Contact:

telnet: `spacelink.msfc.nasa.gov` (192.149.89.61)
modem: (205) 895-0028

NASA's Ames Research Center in California allows public access through the Internet network to a large collection of information on NASA's missions, as well as image display software, digital image files in a variety of formats, and captions for all the released (press) images. Magellan imagery is available in GIF and VICAR formats. In addition, the Magellan CD-ROMs are available in rotation with other NASA image CD-ROMs as a pair of publicly accessible directories. Contact:

ftp: `ames.arc.nasa.gov` (128.102.18.3)
user: `anonymous`
cd: `pub/SPACE/MAGELLAN, VICAR, GIF, CDROM, CDROM2, SOFTWARE`

The PDS Geosciences Node at Washington University (described earlier) permits access through the Internet network to selected Magellan data and documentation. Contact:

ftp: `wuarchive.wustl.edu` (128.252.135.4)
user: `anonymous`
cd: `graphics/magellan`

Other Sources

The Astronomical Society of the Pacific, a non-profit scientific and educational organization, sells a number of Magellan materials, including a set of 20 slides with an information booklet, a teacher's newsletter, and a videotape. Contact:

Astronomical Society of the Pacific
390 Ashton Avenue
San Francisco, California 94112
(415) 337-1100, Facsimile: (415) 337-5205

Sets of 35mm slides with a short printed description of the images, or sets of slides with audio cassette tape narrations can be purchased from:

Finley Holiday Film Corporation
12607 E. Philadelphia St.
Whittier, California 90601
(213) 945-5325, Facsimile: (213) 693-4756

JPL's Employee Recreation Club sells some Magellan materials, currently including a slide set with a short description of the images and a paper model of the spacecraft. The materials available change with time, and may include pins, badges, and other unique items.

Jet Propulsion Laboratory
Employee Recreation Club
Mail Stop 114-104
4800 Oak Grove Drive
Pasadena, California 91109
(818) 354-6120, Facsimile: (818) 393-6632

The Planetary Society, a non-profit organization interested in supporting the nation's planetary research program, sells a number of materials, including a videotape of Magellan computer-generated flights over the surface of Venus. Contact:

The Planetary Society
65 North Catalina Avenue
Pasadena, California 91106
(818) 793-1675
Facsimile: (800) 966-STAR or (818) 793-5528

The Smithsonian's Air and Space Museum sells a wide variety of unusual materials, including slide sets and videotapes on planetary exploration. Contact:

Smithsonian Institution
Air and Space Museum Shop
4th and Independence Avenue, SW
Washington, DC 20560
To obtain a catalog: (703) 455-1700
To order from the catalog: (202) 357-1826
To order from the shop (items not yet in the catalog): (703) 603-6041
Attention: Susie or Yvonne

NASA TEACHER RESOURCE CENTERS

NASA Education Division

NASA's Education Division provides educational programs and materials for teachers and students from the elementary to the university level. The NASA Teacher Resource Center Network, a dissemination mechanism to provide educators with NASA educational materials, is one of the programs that has helped science and mathematics teachers over the years.

NASA Teacher Resource Center Network

Teachers need immediate access to the information that is generated by NASA programs, technologies, and discoveries, so they can bring that excitement into their classrooms. NASA educational materials are related to art, mathematics, energy, physics, careers, spaceflight, aeronautics, technology utilization, physical science, and social science. They are a valuable supplement to the curriculum.

To help disseminate these materials to elementary and secondary educators, the NASA Education Division has established the NASA Teacher Resource Center Network (TRCN). The Network comprises Teacher Resource Centers (TRCs) located at NASA centers, Regional Teacher Resource Centers (RTRCs) at colleges and museums, and the Central Operation of Resources for Educators (CORE).

Teacher Resource Centers

Located at the nine NASA research centers, TRCs have a variety of NASA-related educational materials in several formats: videotapes, slides, audio tapes, publications, lesson plans, and activities. NASA educational materials are available to be copied at the TRCs.

Regional Teacher Resource Centers

To offer more educators the opportunity to visit the TRCN, NASA forms partnerships with universities and museums to serve as RTRCs and plans to have RTRCs as broadly distributed geographically as possible. Teachers may preview NASA materials at these RTRCs or make copies of the materials.

Central Operation of Resources for Educators (CORE)

Designed for the national and international distribution of aerospace educational materials to enhance the NASA Teacher Resource Center Network, CORE provides educators with another source for NASA educational audiovisual materials. CORE will process teacher requests by mail for a minimal fee. On school letterhead, educators can request a catalogue and order form from:

Ms. Tina Salyer
NASA CORE
Lorain County Joint Vocational School
15181 Route 58 South
Oberlin, OH 44074
(216) 774-1051, ext 293/294
Fax: (216) 774-2144

Other Specialized Resource Centers

Serving inquiries related to space exploration and other activities:

NASA Jet Propulsion Laboratory

Teacher Resource Center
JPL Educational Outreach
4800 Oak Grove Drive
Mail Code CS-530
Pasadena, CA 91109
(818) 354-6916 Fax: (818) 354-8080

Serving all states through workshops and materials:

National Air and Space Museum

Smithsonian Institution
Education Resource Center, MRC 305
Washington, DC 20560
(202) 786-2109 Fax: (202) 786-2262

NASA TRCs/RTRCs

Delaware
District of Columbia
Maine
Maryland
Massachusetts
New Hampshire
New Jersey
New York
Pennsylvania
Rhode Island
Vermont

NASA Goddard Space Flight Center

Teacher Resource Laboratory
Mail Code 130.3
Greenbelt, MD 20771
(301) 286-8570 Fax: (301) 286-2184

Delaware Teacher Center/NASA Regional Teacher Resource Center

Newark High School
Newark, DE 19711
(302) 736-6723 Fax: none

The City College

NASA Regional Teacher Resource Center
NAC Building, Room 5/224
Convent Avenue at 138th Street
New York, NY 10031
(212) 650-6993 Fax: none

NASA Teacher Resource Center

823 William Pitt Union
University of Pittsburgh
Pittsburgh, PA 15260
(412) 648-7008 Fax: (412) 648-7003

University of the District of Columbia

NASA Regional Teacher Resource Center
Mail Stop 4201
4200 Connecticut Ave., N.W.
Washington, DC 20008
(202) 282-7338 Fax: (202) 282-3677

Vermont College

NASA Regional Teacher Resource Center
Schulmier Hall
Montpelier, VT 05602
(802) 828-8845 Fax: (802) 828-8855

Wallops Flight Facility

Education Complex--Visitor Center
NASA Teacher Resource Center
Bldg. J-17
Wallops Island, VA 23337

Florida
Georgia
Puerto Rico
Virgin Islands

NASA

John F. Kennedy Space Center
Educators Resources Laboratory
Mail Code ERL
Kennedy Space Center, FL 32899
(407) 867-4090 Fax: none

Alaska
Arizona
California
Hawaii
Idaho
Montana
Nevada
Oregon
Utah
Washington
Wyoming

NASA Ames Research Center
Teacher Resource Center
Mail Stop TO-25
Moffett Field, CA 94035
(415) 604-3574 Fax: (415) 604-3445

**NASA Dryden Flight
Research Facility**
Public Affairs Office (Trl. 42)
NASA Teacher Resource Center
Edwards AFB, CA 93523
(805) 258-3456 Fax: (805) 258-3566

Flandrau Science Center
NASA Regional Teacher Resource Center
University of Arizona
Tucson, AZ 85721
(602) 621-4515 Fax: (602) 621-8451

NASA Johnson Space Center
Teacher Resource Center
Mail Code AP-4
Houston, TX 77058
(713) 483-8696 Fax: (713) 483-4876

**Kansas Cosmosphere and Space
Center**
NASA Regional Teacher Resource Center
1100 North Plum
Hutchinson, KS 67501
(316) 662-2305/665-3387
Fax: (316) 662-3693

Oklahoma State University
NASA Regional Teacher Resource Center
300 North Cordell
Stillwater, OK 74078-0422
(405) 744-7015 Fax: (405) 744-7785

University of Washington
NASA Regional Teacher Resource Center
AK-50, c/o Geophysics Department
Seattle, WA 98195
(206) 543-1943 Fax: (206) 685-3815

University of Wyoming
NASA Regional Teacher Resource Center
Learning Resource Center
P.O. Box 3374 University Station
Laramie, WY 82071-3374
(307) 766-2527 Fax: (307) 766-3062

U.S. Space Foundation
NASA Regional Teacher Resource Center
1525 Vapor Trail
Colorado Springs, CO 80916
(719) 550-1000 Fax: (719) 550-1011

University of New Mexico
NASA Regional Teacher Resource Center
University College
Albuquerque, NM 87131
(505) 277-2631 Fax: (505) 277-3173

Colorado
Kansas
Nebraska
New Mexico
North Dakota
Oklahoma
South Dakota
Texas

Kentucky
North Carolina
South Carolina
Virginia
West Virginia

NASA Langley Research Center
Teacher Resource Center
Mail Stop 146
Hampton, VA 23665-5225
(804) 727-0900 Fax: (804) 727-0898

Murray State University
NASA Regional Teacher Resource Center
Waterfield Library
Murray, KY 42071
(502) 762-4420 Fax: (502) 762-3736

**University of North Carolina -
Charlotte**
NASA Regional Teacher Resource Center
J. Murrey Atkins Library
Charlotte, NC 28223
(704) 547-2559 Fax: (704) 547-3050

Wheeling Jesuit College
NASA Regional Teacher Resource Center
220 Washington Avenue
Wheeling, WV 26003
(304) 243-2388 Fax: (304) 243-2497

Illinois
Indiana
Michigan
Minnesota
Ohio
Wisconsin

NASA Lewis Research Center
Teacher Resource Center
Mail Stop 8-1
21000 Brookpark Road
Cleveland, OH 44135
(216) 433-2017 Fax: (216) 433-8000

Central Michigan University
NASA Regional Teacher Resource Center
Ronan Hall, Room 101
Mount Pleasant, MI 48859
(517) 774-4387 Fax: (517) 774-3152

Mankato State University
NASA Regional Teacher Resource Center
Department of Curriculum and Instruction
MSU Box 52/P.O. Box 8400
Mankato, MN 56002-8400
(507) 389-5710 or -1516
Fax: (507) 389-5853

**Chicago Museum of Science
and Industry**
NASA Regional Teacher Resource Center
57th Street and Lakeshore Drive
Chicago, IL 60637-2093
(312) 684-1414 x429 Fax: (312) 684-5580

Northern Michigan University
NASA Regional Teacher Resource Center
Olson Library Media Center
Marquette, MI 49855
(906) 227-2270 Fax: (906) 227-1333

Oakland University
NASA Regional Teacher Resource Center
O'Dowd Hall, Room 216
Rochester, MI 48309-4401
(313) 370-2485 Fax: (313) 370-4226

Parks College of St. Louis University
NASA Regional Teacher Resource Center
500 Falling Springs Road
Cahokia, IL 62206
(618) 337-7500 Fax: (618) 332-6802

St. Cloud State University
Center for Information Media
NASA Regional Teacher Resource Center
720 4th Avenue South
St. Cloud, MN 56301-4498
(612) 255-2062 Fax: (612) 255-4778

University of Evansville
NASA Regional Teacher Resource Center
School of Education
1800 Lincoln Avenue
Evansville, IN 47722 (812) 479-2393
Fax: none

University of Wisconsin at LaCrosse
NASA Regional Teacher Resource Center
Morris Hall, Room 200
LaCrosse, WI 54601
(608) 785-8148 or -8650
Fax: (608) 785-8909

Alabama
Arkansas
Iowa
Louisiana
Missouri
Tennessee

U. S. Space and Rocket Center
NASA Teacher Resource Center
1 Tranquility Base
Huntsville, AL 35807
(205) 544-5812 or
(205) 837-3400, Ext 115

Southern University
NASA Regional Teacher Resource Center
Downtown Metro Center
610 Texas Street
Shreveport, LA 71101 (318) 674-3444
Fax: (318) 674-3385

Bossier Parish Community College
NASA Regional Teacher Resource Center
2719 Airline Drive
Bossier City, LA 71111
(318) 746-7754 Fax: (318) 742-8664

University of Northern Iowa
NASA Regional Teacher Resource Center
Curriculum Laboratory Room 222
Schindler Education Center
Cedar Falls, IA 50614-0609
(319) 273-6066 Fax: (319) 273-6997

Mississippi

NASA Stennis Space Center
Teacher Resource Center
Building 1200
Stennis Space Center, MS 39529-6000
(601) 688-3338 Fax: (601) 688-7528

Tri-State Learning Center (SSC-TRC)
NASA Teacher Resource Center
P. O. Box 508
Iuka, MS 38852-508
(601) 423-4373 Fax: (601) 423-4375

Mississippi Delta Community College
NASA Regional Teacher Resource Center
P.O. Box 668
Moorehead, MS 38761
(601) 246-5631 x126 Fax: (601) 246-8627

User Information

For more information, contact the Center Education Program Officer (CEPO) for the region in which the TRC/RTRC is located.

Alaska
Arizona
California
Hawaii
Idaho

Montana
Nevada
Oregon
Utah
Washington
Wyoming

Mr. Garth A. Hull, Chief
Educational Programs Branch
Mail Stop TO-25
NASA Ames Research Center
Moffett Field, CA 94035
Phone: (415) 604-5543 Fax: (415) 604-3445

Connecticut
Delaware
District of Columbia
Maryland
Massachusetts
Maine

New Hampshire
New Jersey
New York
Pennsylvania
Rhode Island
Vermont

Mr. Elva Bailey
Educational Programs Public Affairs
Officer (130.3)
NASA Goddard Space Flight Center
Greenbelt, MD 20771
Phone: (301) 286-7207 Fax: (301) 286-8142

Colorado
Kansas
Nebraska
New Mexico

North Dakota
Oklahoma
South Dakota
Texas

Dr. Robert W. Fitzmaurice
Center Education Programs Officer
Public Affairs Office (AP-4)
NASA Johnson Space Center
Houston, TX 77058
Phone: (713) 483-1257 Fax: (713) 483-4876

Florida
Georgia

Puerto Rico
Virgin Islands

Mr. Raymond R. Corey
Chief, Education and Awareness Branch
Mail Code PA-EAB
NASA Kennedy Space Center
Kennedy Space Center, FL 32899
Phone: (407) 867-4444 Fax: (407) 867-3395

Kentucky
North Carolina
South Carolina

Virginia
West Virginia

Dr. Karen R. Credeur
Head, Office of Public Services
Mail Stop 154
NASA Langley Research Center
Hampton, VA 23665-5225
Phone: (804) 864-3307/3312
Fax: (804) 864-7732

Illinois
Indiana
Michigan

Minnesota
Ohio
Wisconsin

Dr. Lynn Bondurant
Chief, Office of Educational Programs
Mail Stop 7-4
NASA Lewis Research Center
21000 Brookpark Road
Cleveland, OH 44135
Phone: (216) 433-5583 Fax: (216) 433-3344

Alabama
Arkansas
Iowa

Louisiana
Missouri
Tennessee

Mr. Bill Anderson
Chief, Education Branch
Public Affairs Office (CA21)
NASA Marshall Space Flight Center
Marshall Space Flight Center, AL 35812
Phone: (205) 544-7391 Fax: (205) 544-5852

Mississippi

Dr. Marco Giardino
Center Education Program Officer
Mail Stop HA 00
NASA John C. Stennis Space Center
Stennis Space Center, MS 39529
Phone: (601) 688-2739 Fax: (601) 688-1925

The Jet Propulsion Laboratory
can provide special assistance
with questions about NASA's
planetary exploration program
and other JPL activities.

Mr. Richard Alvidrez
Public Education Office
Jet Propulsion Laboratory
Mail Code 180-205
4800 Oak Grove Drive
Pasadena, CA 91109
Phone: (818) 354-8592 Fax: (818) 354-8080



▶ USING THE MAGELLAN CD-ROMS

The current Magellan CD-ROMs contain the digital image mosaics produced by the spacecraft's synthetic aperture radar instrument during the first 243-day cycle around Venus. Individual disks contain Full-Resolution Mosaic Image Data Records (F-MIDRs), which show the imagery at full resolution, or Compressed (Once or Twice) Mosaic Image Data Records (C1-MIDRs, C2-MIDRs) which cover larger areas at lower resolution. The C-MIDRs cover the entire planet, while the F-MIDRs cover selected areas of probable interest, comprising in total about 15 percent of the planet.

These disks are the basic archive of Magellan's scientific data for both research and public interest. They have been designed to be usable on all types of computers. The National Space Science Data Center (NSSDC) is the principal distributor of the CD-ROM disks. NSSDC can also provide software to display the images on most computers. NSSDC can be reached at:

National Space Science Data Center

Goddard Space Flight Center
Coordinated Request and User Support Office
Mail Code 933.4
Greenbelt, Maryland 20771
(301) 286-6695, Facsimile: (301) 286-4952

On-line Catalog: NSSDC::
or nssdc.gsfc.nasa.gov (128.183.36.25)
Username: nssdc
E-mail: NSSDC::REQUEST
or request@nssdc.gsfc.nasa.gov

The CDs have been produced in approximately the order in which their imagery was collected by the Magellan spacecraft. However, identifying the precise disk which is needed to view a specific feature or area can be difficult. NSSDC can also provide a simple program which tells the latitude and longitude of any named feature on Venus, and then shows the specific CD-ROM(s) and mosaic images which cover that area.

The images are stored in directories named by the latitude and longitude at which the mosaic is centered. Each directory contains a "browse" image, which shows the entire mosaic at reduced resolution, and 56 "tiles," which show the mosaic broken into smaller pieces of 7 rows by 8 columns. Each image consists of a pair of files, named *.img and *.lbl, the "image" and "label" files.

Each digital image is in VICAR format, the standard Jet Propulsion Laboratory format for digital imagery. VICAR stores individual pixels by row and column, with a single extra initial row describing the image in ASCII text. If you wish, you can read this first row (the "VICAR label") as text. You can also read as text the *.lbl file, which contains a complete description of the image file in a form which both you and your computer can understand. You can convert the imagery from VICAR into other formats (GIF, PICT, ...) for use with other software.

Getting Started

The first necessity is a CD-ROM reader. It is important that the drivers for the CD-ROM reader properly support the ISO-9660 standard. Older drivers which do not properly implement this standard will typically show the disks or subdirectories (folders) to be empty. Since drivers are specific to different CD-ROM readers, you should first contact your hardware supplier. Appropriate drivers for some of the most common CD-ROM readers can be obtained from NSSDC.

IBM-type personal computers need both a driver for the CD-ROM player and Microsoft's CD-ROM extensions for DOS. The driver is typically placed in the CONFIG.SYS file in your C:\ directory. The CD-ROM extensions are typically invoked through a batch file, either the AUTOEXEC.BAT file which runs as the computer starts, or a separate batch file run just before using the CD-ROM player. These two pieces of software use parts of the computer's memory, and may interfere with running other programs which use very large amounts of memory.

Macintosh computers need a set of CD-ROM files placed into their System folder in order to use the CD-ROM drive. After loading these files, the computer must be re-started, with the CD-ROM drive turned on before the computer itself. Since Macintosh CD-ROM drives are normally SCSI devices, it is important to avoid conflicts in the cabling, addressing, or termination with other SCSI devices connected to the computer.

Once you have the appropriate software installed, you can "open" the CD-ROM disk just as you would any other computer disk. On an IBM-type machine, you can change to the CD disk, change to a subdirectory, display the contents, or type a file. On a Macintosh, you can double-click on the CD icon to open the disk. CD-ROMs' particular strength is the amount of data they contain, rather than their speed. If you are going to work extensively with any file or image, it may be wise to copy it onto your hard disk first and use it there in order to speed up your work.

You might find it interesting that the Magellan CD-ROMs can actually be played in your audio CD player. Be sure to turn the volume down to minimum before you try this. The sound you hear will be a fairly loud buzz; it is the same data used to store the images for your computer, interpreted as though it were music.

What Are All These Files?

The Magellan CD-ROMs contain a number of files besides the image files themselves. The most useful is a file in the top directory of the CD named "AAREAD.ME", which describes the disk's contents in considerable detail. Like the other non-image files, it can be read with any word processor. If you are using a Macintosh, you may find that the file contains characters at the end of each line which the Macintosh doesn't recognize (linefeeds) and shows as "boxes." You can either ignore them, or remove them with your word processor.

Each disk contains a file that can act as an index of the named geologic features on Venus. This file can be loaded into a spreadsheet or database and used to locate features. (This function can also be performed using the special program from NSSDC described

above.) Each disk also has a set of the accumulated "problem reports" for earlier disks.

IBM-Type Personal Computers

IMDISP, the IBM-type personal computer image display software available from NSSDC, should be loaded into a directory on your hard disk. This directory should be added to the "path" specified in your AUTOEXEC.BAT file, so that IMDISP can be executed easily. Alternatively, use a batch file in a common batch directory which is on the path to locate and run IMDISP. The program is distributed in a compressed form which needs to be de-compressed with the program PKUNZIP before it can be run.

IMDISP works with IBM-type personal computers with at least EGA display cards. Much better results are obtained with VGA displays, and still better with Super-VGA displays. IMDISP can be adjusted to work with a variety of different Super-VGA displays, as explained in its documentation. To see the up-to-date list of displays supported, type "help set" at the IMDISP prompt. If your display system is one of those specifically listed, you can type "set display ..." (where ... represents one of the possible choices, such as ATI800) at IMDISP's prompt to configure the display, or enter the line "set imdisp=..." in your CONFIG.SYS file. If your Super-VGA display is not one of those listed and you wish to experiment, type "set disp ..." and observe whether the screen is readable, or stays blank. If it stays blank, type "set disp vga" (in the blind) and the display will return. Work your way through the list until you find one which works.

IMDISP will use very large amounts of expanded memory if it is available. This memory will be used to buffer the data read from the CD-ROM, so that subsequent manipulation of the image is much faster. However, the program will run in machines with only 640K of memory.

To start the program, type "imdisp". Change drives to the CD-ROM drive just as you would in DOS. That is, if you set up the CD-ROM to be drive "H", type "H:" at the IMDISP prompt. Then type "files". Use the display of directory and file names to move to the image which you wish to view. If you wish at first to

see only the browse images, rather than the long list of tiles, type "file browse.*". For the best performance, rather than selecting the *.img file which you wish to view, select the corresponding *.lbl file. The label file gives IMDISP extra information about the image which allows it to work more effectively.

If you are viewing a browse image, you may use the cursor (controlled by either the arrow keys or a mouse) to mark a particular region, and then ask IMDISP to call up the higher-resolution "tile" of the area selected. Type "cursor", move the cursor until it is on the area which interests you, and then hit the "period" key. Then type "disp source" to bring up the high resolution image centered on the cursor.

IMDISP allows a wide range of image processing procedures, including zooming, changing the brightness and contrast, and coloring the image. The command "help" and the IMDISP documentation explain these capabilities. In addition, IMDISP can be commanded to "browse" through all of a set of images (including the entire disk), or to perform a set of commands repeatedly in order to cycle through a display of images. IMDISP can save an image which has been processed, either as a VICAR image or in the GIF format, if the file name chosen is *.gif. The GIF format can be displayed on a very wide range of computers, including many inexpensive types.

Macintosh Computers

In order to display the Magellan images, you will need a Macintosh computer with at least an 8-bit color display card (although it may have a grey-scale monochrome display). You need the file "32-bit Quickdraw" in your System folder. You will also need as much memory as possible; at least 4 megabytes is recommended. Your computer should have a numeric co-processor. If not, it will be necessary to use a special file placed into your System folder to cause the computer to emulate the co-processor in software. Such emulation will reduce the speed of the program markedly.

Several programs are available for the Macintosh to display the Magellan images. The newest and most flexible is "Image4PDS" (Image for Planetary Data System CD-ROMs). This is a modified version of

"Image 1.41," which was developed by the National Institutes of Health. The modification allows the program to open the Magellan images by "opening" the *.lbl file corresponding to the image. Unmodified versions of Image have difficulty opening the CD-ROM files directly.

Place the Image program into a folder on your hard disk. The program is distributed in compressed form and needs to be de-compressed with STUFFIT before it can be run. If you are running under Multifinder, it is wise to allocate as much memory as possible to Image through its Information box. When you first open Image, you may wish to adjust the sizes of the Cut and Paste buffers, set them as the default, and then restart the program. Large buffers are necessary if you wish to extract part of the image into a new image. Small buffers allow you to open large images in a machine with limited memory.

Use the "Open" command (Command-O) to select the CD-ROM drive, the desired folder, and the desired image. (Select the *.lbl, not the *.img file.) You can use normal Macintosh commands to adjust the size of the image window, or move it on the screen. A selection of "tools" lets you scroll the image within the window, adjust its brightness and contrast, change the magnification, and color the image. You can have multiple images open simultaneously in separate windows. Image lets you save the file in a number of formats, including PICT, which can be used by many different Macintosh programs.

Try Before You Buy

It is possible to try out some of the Magellan images even if you don't yet own a CD-ROM drive. You will need the display software from NSSDC appropriate for your computer and either a modem or a connection to the Internet computer network. Alternatively, you may be able to ask a friend to copy the images onto a diskette for you. The limitation of this approach is that the Magellan image files are quite large, and therefore take time to move electronically (or fill diskettes quickly). CD-ROMs are particularly effective for distributing such large sets of data easily. Some sources of Magellan images are the following:

- ❑ SPACELINK is intended to provide information useful for school teachers and contains a collection of digital images, as well as some of the "browse" images showing the standard mosaic images. SPACELINK's images are in GIF format, which helps to make them smaller and suitable for display on a variety of inexpensive classroom computers. They are accompanied by text files which give the captions released with the images. IMDISP will display the GIF images on IBM-type computers; a variety of GIF viewers exist for the Macintosh. You can connect to SPACELINK either through the Internet or by modem.

telnet: spacelink.msfc.nasa.gov (192.149.89.61)
modem: (205) 895-0028

- ❑ NASA's Ames Research Center in California allows public access through the Internet network to a large collection of information on NASA's missions, as well as image display software, digital image files in a variety of formats, and captions for all the released (press) images. Magellan imagery is available in GIF and VICAR formats. In addition, the Magellan CD-ROMs are available in rotation with other NASA image CD-ROMs as a pair of publicly accessible directories. Contact:
ftp: ames.arc.nasa.gov (128.102.18.3)
user: anonymous
cd: pub/SPACE/MAGELLAN, VICAR, GIF, CDROM, CDROM2, SOFTWARE
- ❑ The PDS Geosciences Node at Washington University permits access through the Internet network to selected Magellan data and documentation. Contact:
ftp: wuarchive.wustl.edu (128.252.135.4)
user: anonymous
cd: graphics/magellan

- ❑ If your problem is difficulty in understanding how to install your CD-ROM drive and its drivers, you need to consult your hardware supplier or a friend who has experience with such hardware.
- ❑ If the CD-ROM disks appear to be blank, or you cannot open the sub-directories (folders), you probably have old driver software which cannot handle the ISO-9660 standard and need to obtain up-to-date versions.
- ❑ If you cannot read a software diskette from NSSDC, please try it in another machine, check that it is intended for your machine, and ensure that you are not placing a high-density diskette into a low-density drive.
- ❑ Ensure that you have the appropriate hardware with which to actually show the images. Older personal computers, particularly IBMs with mono chrome (Hercules) displays, will not work, nor will small monochrome Macintoshes (Mac Plus, SE, ...). IBMs with EGA displays will work, but the images shown will be very discouraging. It is possible to show GIF images on inexpensive machines, but it is difficult to obtain results which really show the Magellan imagery satisfactorily.
- ❑ If you are a teacher, the system of NASA Teacher Resource Centers may have a center near you which could provide assistance. In addition to helping you display the imagery, they may be able to assist with other material to use in incorporating the Magellan data into your teaching.
- ❑ NSSDC is not able to provide detailed assistance to users in making the Magellan CD-ROMs work. A special Magellan Support Office has been established at Washington University to provide more assistance than NSSDC can supply.

For Further Help

The best source for further help will depend on your problem, your location and what type of user you are.

- ❑ The Lord created documentation to be read. (He didn't promise it would be easy to read, but ...)

Magellan Data Products Support Office

Planetary Data System, Geosciences Node
Earth and Planetary Remote Sensing Laboratory
Washington University, Campus Box 1169
One Brookings Drive
St. Louis, Missouri 63130-4899
(314) 935-5493, Facsimile: (314) 935-7361
E-mail: WURST::MGNSO or
mgnso@wurst.wustl.edu
(128.252.135.4)

The Washington University PDS node provides a direct and knowledgeable source of assistance in using Magellan data through a Magellan Data Products Support Office. The purpose of the Support Office is to provide users with information about and assistance in getting Magellan data. Standard and special data products are supported, including digital products, photoproducts, slides, videotapes, and NASA Public Information Office (PIO) products. The Support Office serves NASA-sponsored scientists, other researchers and educators, and the general public.

The Support Office is staffed by researchers experienced in working with Magellan data products. The primary contact is Dr. Edward Guinness. The Office can answer questions such as what data products exist, where they can be obtained and at what cost, and how to read digital data products. The Office can provide the information necessary to complete an NSSDC order form and will help users place an order.

In general, a user is referred to NSSDC when the Support Office is certain that NSSDC has the product in question. The Support Office gives the user the phone number and/or electronic mail address of NSSDC, and helps the user determine exactly what to request. For a non-standard product, or when the Support Office is not certain that NSSDC has a product, the Office tries to locate information about the product and then calls the user back. It then does whatever it can to help the user obtain the product.

NSSDC personnel will refer a user to the Magellan Data Products Support Office in cases where they cannot help the user and know the Support Office can. If NSSDC is not sure the Support Office has the answer, it will work directly with the Support Office to find the information, and then get back to the user. The Support Office does not:

- ❑ Fill orders for standard products from the Geosciences Node inventory when the orders can be filled by NSSDC. Exceptions are made in special cases, for example if NSSDC is temporarily out of stock and the Geosciences Node can easily provide the product.
- ❑ Provide users with accounts on Geosciences Node computers. The Office will help users obtain accounts on the Planetary Data System computer in order to use the Magellan Detailed-Level Catalog or other parts of the PDS Catalog.



▶ APPENDIX A – REGIONAL PLANETARY IMAGE FACILITIES

The Planetary Geology and Geophysics Program co-sponsors an international system of regional planetary image facilities (RPIFs). These facilities function as a library of planetary image data and associated information. Each of the 15 facilities contains nearly half a million planetary images. The facilities maintain photographic copies and digital data. In addition, several RPIFs offer workstations for users to conduct on-site image and cartographic processing. Each facility's general holdings, containing images of planets and their satellites taken from both Earth and space, together with topographic and geologic maps produced from these images, include the following:

▶ The Moon

Selected Earth-based telescopic photos
Ranger 7 through 9
Surveyor 1, 3, 5 through 7
Lunar Orbiter 1 through 5
Apollo 8, 10 through 17

▶ Mercury

Mariner 10

▶ Venus

Mariner 10
Pioneer Venus
Magellan

▶ Mars and Its Satellites

Mariner 4, 6, 7, and 9
Viking Orbiter 1 and 2
Viking Lander 1 and 2

▶ Jupiter and Its Satellites

Voyager 1 and 2
Pioneer 10 and 11

▶ Saturn and Its Satellites

Voyager 1 and 2
Pioneer 11

▶ Uranus, Neptune and their Satellites

Voyager 2

Each facility has a video disk system that allows users to rapidly scan a collection of images. Additionally, holdings may be searched through an on-line data catalog that is supported by the network of RPIFs. Because the RPIFs are reference centers for studying and selecting lunar and planetary images, images are not permitted to leave except under exceptional circumstances. Reproductions of a few photographs at the user's expense may be possible, however, data managers are available to assist with the ordering of materials for user's retention from the National Space Science Data Center (NSSDC) in Greenbelt, Maryland.

Regional Planetary Image Facilities are located at the following institutions in the United States and Overseas:

Space Imagery Center

Lunar and Planetary Laboratory
University of Arizona
Tucson, AZ 85721
(602) 621-4861 Fax: (602) 621-4933

Arizona State University

Space Photography Laboratory
Department of Geology
Tempe, AZ 85287-1404
(602) 965-7029 Fax: (602) 965-8102

Planetary Data Center

Brown University
Department of Geological Sciences
Box 1846
Providence, RI 02912
(401) 863-3243 Fax: (401) 863-3978

Cornell University

Spacecraft Planetary Imaging Facility
317 Space Sciences Building
Ithaca, NY 14853-6801
(607) 255-3833 Fax: (607) 255-9002

University of Hawaii

Pacific Regional Planetary Data Center
Planetary Geosciences
2525 Correa Road
Honolulu, HI 96822
(808) 956-3131 Fax: (808) 956-6322

Jet Propulsion Laboratory

California Institute of Technology
Mail Stop 202-101
4800 Oak Grove Drive
Pasadena, CA 91109
(818) 354-3343 Fax: (818) 354-3437

Lunar and Planetary Institute

Center for Research and Information Services
3600 Bay Area Blvd.
Houston, TX 77058-1113
(713) 486-2136 or -2182 Fax: (713) 486-2186

Center for Earth and Planetary Studies

National Air and Space Museum
4th & Independence Avenue, S.W.
Room 3790
Smithsonian Institution
Washington, DC 20560
(202) 357-1457 Fax: (202) 786-2566

U.S. Geological Survey

Branch of Astrogeology
2255 North Gemini Drive
Flagstaff, AZ 86001
(602) 556-7262 Fax: (602) 556-7090

Department of Earth and Planetary Sciences

Campus Box 1169
Washington University
St. Louis, MO 63130
(314) 935-6652 Fax: (314) 935-7361

OVERSEAS FACILITIES**DFVLR Oberpfaffenhofen**

RPIF
NE-OE-PE
8031 Wessling
Germany
011 (49) 89 520-2417
Fax: 011 (49) 8153-2476

ISAS

Division of Planetary Science
3-1-1 Yoshinodai
Sagamihara
Kanagawa 229
Japan
011 (81) 427-51-3925
Fax: 011 (81) 427-59-4237

Phototheque Planetaire d'Orsay

Laboratoire de Geologie Dynamique Interne
Batiment 509
Universite Paris-Sud
F-91405 Orsay Cedex
France
011 (33) 1 69-41-61-49 or
51 Fax: 011 (33) 1 60-19-14-46
TELEX: FACORS 602166F

Southern-Europe RPIF

c/o Istituto di Astrofisica Spaziale-CNR
Reparto di Planetologia
Viale dell'Universita' n. 11
00185 Rome
Italy
011 (39) 6 49-56-951

University of London Observatory

Observatory Annex and ULO Planetary Image
Center
33-35 Daws Lane
Mill Hill
London NW7 4SD
England
011 (44) 81 959 0421
Fax: 011 (44) 71 380 7145

APPENDIX B – PLANETARY DATA SYSTEM NODES

Central Node

- ▶ **Planetary Data System**
Jet Propulsion Laboratory
4800 Oak Grove Drive
Mail Stop 525-3610
Pasadena, California 91109
(818) 306-6130
Facsimile: (818) 306-6929
VAXmail: jplpds::pds_operator
- ▶ Andrea Alazard
PDS Administrator
(818) 306-6028
VAXmail: jplpds::pdssa

Atmospheres Node

- ▶ **University of Colorado**
LASP Campus Box 392
Boulder, CO 80309
- ▶ Steve Lee
(303) 492-5348
Fax: (303) 492-6946
NASAmail: SWLEE
VAXmail: oroin::lee
- ▶ Randy Davis
(303) 492-5081
Fax: (303) 492-5105
NASAmail: RLDAVIS
VAXmail: aquila::davis

Geosciences Node

- ▶ **Washington University**
Campus Box 1169
One Brookings Drive
St. Louis, MO 63130-4899
Fax: (314) 935-7361
- ▶ Ray Arvidson
(314) 935-5609
NASAmail: RARVIDSON
VAXmail: wurst::arvidson
- ▶ Ed Guinness
(314) 935-5493
NASAmail: EGUINNESS
VAXmail: wurst::guinness

Imaging Node

- ▶ **USGS Astrogeology**
2255 N. Gemini Dr.
Flagstaff, AZ 86001
Fax: (602) 556-7014
- ▶ Larry Soderblom
(602) 556-7018
NASAmail: LSODERBLOM
VAXmail: astrog::lsoderblom
- ▶ Eric Eliason
(602) 556-7113
NASAmail: EELIASON
VAXmail: astrog:eeliason

NAIF Node

- ▶ **JPL**
MS 301-125L
4800 Oak Grove Dr.
Pasadena, CA 91109
(818) 354-3869
Fax: (818) 393-6388
- ▶ Chuck Acton
NASAmail: CACTON
VAXmail: naif::cha
- ▶ **Planetary Plasma Interactions**
UCLA IGPP
Los Angeles, CA 90024
Fax: (310) 206-8042
- ▶ Ray Walker
(310) 825-7685
NASAmail: RAYWALKER
VAXmail: uclasp::rwalker
- ▶ Steve Joy
(310) 206-6073
NASAmail: SJOY
VAXmail: uclasp::sjoy

Rings Node

- ▶ **NASA/AMES Research Center**
MS 245-3
Moffett Field, CA 94035
Fax: (415) 604-6779

- ▶ Jeff Cuzzi
(415) 604-6343
NASAmail: JNCUZZI
VAXmail: gal::cuzzi

- ▶ Mark Showalter
(415) 604-3382
NASAmail: MSHOWALTER
VAXmail: gal::showalter

Small Bodies Node

- ▶ **University of Maryland**
Astronomy Program
College Park, MD 20742
Fax: (301) 314-9067

- ▶ Michael A'Hearn
(301) 405-6076
NASAmail: MAHEARN
VAXmail: east:"ma@astro.umd.edu"

- ▶ Ed Grayzeck
(301) 405-1539
VAXmail: nssdca::grayzeck

SIS Reverse Reference List

SIS Reverse Reference List (RRL)

Introduction: Science readers and users of Magellan Software Interface Specifications (SISs) and related documentation have expressed concern over the nested and/or hierarchical structure with which the overall package has been put together. Two problem situations are readily identified:

(1) The user of a SIS must locate and read other SISs in order to discover the format and content of the data product of interest. In some cases the nesting is several layers deep, meaning that considerable time may be lost as these documents are retrieved one at a time and found to be insufficient (because of further nesting).

(2) When one SIS changes, it is difficult (and sometimes impossible) to anticipate consequences to other SISs and to end users. When the nesting is several layers deep, the end user may be completely unaware that a change has taken place in either the format or the content of the data product.

Overview: The following pages contain a reverse reference list to the SIS documents of most interest to science users. That is, each document listed is followed by a list of other documents which reference it. The full list has been culled from Magellan science (and supporting) SISs. An appendix gives single page summaries for each SIS included in the compilation. The complete Reverse Reference List (RRL) is more comprehensive than most science users will require, but all of the data have been retained so that (1) the magnitude of the problem may be appreciated and (2) the impact of supposedly distant documents may be judged.

Caveats: Users of this list should be aware of its limitations. In particular these include:

(1) This list was compiled by hand from SIS documents available in late May 1990. Only TPS-140 (AEDR SIS) had not been signed off at that time, but several documents were undergoing post-approval change. Major changes in applicable document lists or in SIS organization seem unlikely, but that cannot be ruled out. Thus, because of the continued evolution of the SISs and because there are no real checks built into the compilation, the RRL should be used with some respect for its limitations. It should be, however, better than having no list at all.

(2) The same document is often given different identification codes by different organizations, i.e. the Magellan Project, SFOC, HAC, NAIF, MIT, etc. There are also two cases where the Magellan Project has collected several documents under the same code (NAV-135 and TPS-113). In the current document, the Magellan Project code is used whenever it is available. Cross-references to the other names are to be found in the Reverse Reference List, e.g.

JPL D-2719
see PD 630-530

(3) In general the reverse referencing goes to only one level of depth. The heritage of a file which has been simply copied from one product to another to a third, etc. will not be apparent from a casual

glance at the RRL. For example, the Spacecraft and Planet Ephemeris File is specified by SIS NAV-135. This (disk) file is copied to several tapes, including the SAR-EDR (SIS TPS-101) from which it is copied to the F-BIDR (SIS SDPS-101) and thence to the C-BIDR (SIS IDPS-102). The situation is more confusing since the TPS-101 document refers to NAV-135 by its SFOC designation: SFOC-2-DPS-CDB-Ephemeris, which is only one part of NAV-135, the Magellan Project designation. The RRL shows the pairwise reverse referencing but the user must, in general, query the RRL repeatedly (in conjunction with the relevant pages in the appendix) to discover that NAV-135 is needed to interpret the C-BIDR ... or that a change in NAV-135 will be carried to (at least) the C-BIDR product. Limited multi-level reverse referencing has been included (through use of [] notation) where direct copies are involved (in fact, the example given here is covered by this exception).

(4) SIS documents rarely describe more than format. The user should realize that some quantities will be passed on from one product to another even though the format changes. MIDR tapes, for example, are derived from F-BIDR and C-BIDR tapes. The MIDR format is defined almost entirely by IDPS-109. The MIDR user should be aware, however, that there may be circumstances in which some of the MIDR contents will change if the parent F-BIDR or C-BIDR changes.

Dick Simpson and Peter Ford
June 90

Mapping Between MGN Data Product and SIS

The following table shows Magellan data product in the left column and the primary Software Interface Specification (SIS) in the right column.

The user can find the primary SIS in the appendix, which follows, and identify additional SISs which may be needed to unpack the data.

<u>Name</u>	<u>Description</u>	<u>SIS ID</u>
AEDR	Archive Engineering Data Record	TPS-140
ARCDR	Altimetry and Radiometry Composite Data Record	SCI-002
ATDF	Archival Tracking Data File	TRK-105
BADR	Basic Altimetric Data Record	IDPS-119
BRDR	Basic Radiometer Data Record	IDPS-123
C-BIDR	Compressed-Resolution Basic Image Data Record	IDPS-102
F-BIDR	Full-Resolution Basic Image Data Record	SDPS-101
GADR	Global Altimetric Data Record	IDPS-135
GRDR	Global Radiometric Data Record	IDPS-124
GxDR	Global Image Data Record (x = T, S, RE, E)	SCI-001
MIDR	Mosaicked Image Data Record	IDPS-109
ODF	Orbit Data File	TRK-101
PIDR	Polar Image Data Record	IDPS-107
SCI-EDR	Science (SAR or ALT) Experiment Data Record	TPS-101

Simplified Reference List

The following table shows the Software Interface Specification documents that are *absolutely* necessary in order to understand the *format*, but not necessarily the *content*, of each of the Magellan radar data products distributed to the scientific community. A more complete list is to be found in the Appendix, but that list shows only direct dependencies, which must be iterated in order to locate all source documents. The simplified table shows *all* dependencies.

<u>Product</u>	<u>SIS ID</u>	<u>Depends on</u>
ARCDR	SCI-002	NAV-135
BADR	IDPS-119	
BRDR	IDPS-123	SDPS-101
C-BIDR	IDPS-102	SDPS-101, TPS-101, Aux
F-BIDR	SDPS-101	TPS-101, Aux
GADR	IDPS-135	
GRDR	IDPS-124	
GxDR	SCI-001	
MIDR	IDPS-109	
PIDR	IDPS-107	NAV-135, TPS-101
SCI-EDR	TPS-101	Aux

The following documents (shown above as **Aux**) are required in order to read SCI-EDR tapes and several products derived from them.

<u>Mgn ID</u>	<u>Subsystem SIS ID</u>
MON-105	SFOC-1-GIF-DSN-MgnGCFMon
NAV-135	(SFOC-2-DPS-CDB-Ephemeris, NAIF-167.0, NAIF-168.0, NAIF-169.0)
RES-101	SFOC-1-CDB-Mgn-Bandwidth
RES-104	SFOC-1-CDB-MGN-Quaterni
SES-112	SFOC-1-CDB-MGN-SCLKvSCET
SES-115	SFOC-1-DMD-Mgn-DECAL
TPS-113	(SFOC-5-SYS-*DU-NJPL, SFOC-5-TIS-*DU-MgnSFDU, SFOC-5-TIS-*DU-SFDU)
TPS-129	SFOC-1-TIS-Any-DecomRpt

All users of Magellan products should have copies of PD 630-79. In addition, recipients of tape products (all the above except MIDR, ARCDR, and GxDR) will require copies of ANSI X3.27-1978 and ANSI X3.54-1976.

Reverse Reference List

Each entry in the Reverse Reference List includes:

- [1] SIS or document code (if any), **[bold]**
- [2] document title (if any), and **[bold, italicized]**
- [3] other documents (if any) in which it is referenced

If a document is known by more than one code, all the recognized ones are given after the "most commonly encountered" code. For example, the SCIEDR product is described by a SIS known as TPS-101 in some circles and as SFOC-1-MHR-Mgn-SCIEDR in others. The "most commonly encountered" code (for science purposes) is TPS-101, so the SIS is listed in the RRL under that. The other code (SFOC-1-MHR-Mgn-SCIEDR) appears separately in the list, but only with a pointer to TPS-101.

Documents are listed in alpha/numerical order. Where both a document and a section within that document (e.g., 820-13, Rev. A and its sections) are identified separately, the full document appears first and the sections, in alpha/numerical order, follow.

Note that SFOC apparently uses "temporary" codes like SXXXnnnn-nn-nn-nn to designate SISs which are in the process of being written. Designations starting with "SFOC0038-" are particularly common. It was found in compiling the RRL that these were not unique. For example, the code SFOC0038-01-04-01 referred to at least two different SISs. All of the "SFOC0038-" entries have been purged from the RRL, but they remain in the appendix listings. Users of the RRL and appendix should be wary of the others; the preferred (stable and unique) designation for these SISs starts with "SFOC-".

In the few cases where reverse referencing is shown to more than one depth, the additional references are shown set off by square brackets []. For the example above involving the ephemeris file to C-BIDR propagation, the TPS-101 entry is modified to

TPS-101 [SDPS-101 [IDPS-102] [IDPS-107]]

to indicate that the file is copied with at most minor changes through to the C-BIDR (and also to the PIDR, described by IDPS-107). Where more than minor modifications take place, multiple reverse referencing has not been attempted.

ANSI X3.27-1978

American National Standards Institute, Magnetic Tape Label for Information Exchange

IDPS-102
IDPS-107
IDPS-109
IDPS-119
IDPS-123
IDPS-124
IDPS-135
SCI-001
SCI-002
SDPS-101
TPS-101
TPS-140

ANSI X3.54-1976

American National Standards Institute, Recorded Magnetic Tape for Information Interchange (6250 cpi, Group-Coded Recording)

IDPS-102
IDPS-107
IDPS-109
IDPS-119
IDPS-123
IDPS-124
IDPS-135
SDPS-101

DDN Protocol Handbook

NAV-135

DMD SDD

Channel Conversion Language

SES-115

DPTRAJ and ODP (4 volumes)

see PD 630-336

DS 32466-101

VRM Radar System Sensor Subsystem Development Specification

PD 630-204

DS 32466-111

Venus Radar Mapper PRF/Timing Unit Development Specification

PD 630-204

DS 32466-121

Venus Radar Mapper Data Formatter Unit Development Specification

PD 630-204

DS 32466-141

Venus Radar Mapper Telemetry and Command Unit Development Specification

PD 630-204

DS 32466-402
*MGN Software Requirements Document, Radar Mapping Sequencing
Software*

RES-101
RES-104

HS 513-034E
MGN Radar System Software Management Plan
RES-101
RES-104

HS 513-088
VRM Radar System Design Description
PD 630-204

IDPS-102
Compressed-Resolution Basic Image Data Record
SCI-002

IDPS-107
Polar Image Data Record

IDPS-109
Mosaicked Image Data Record

IDPS-119
Basic Altimetric Data Record
IDPS-135

IDPS-123
Basic Radiometer Data Record
IDPS-124

IDPS-124
Global Radiometric Data Record

IDPS-135
Global Altimetric Data Record

JJPL0006-00-02
unknown title
(referenced in RES-101 page 4-1; perhaps it should be JJPL0006-01-00)

JJPL0006-01-00

JPL Standard Formatted Data Unit (SFDU) Usage and Description

IDPS-102
IDPS-107
IDPS-109
IDPS-119
IDPS-123
IDPS-124
IDPS-135
NAV-135
RES-101
RES-104
SCI-001
SCI-002
SDPS-101
NAV-135
TPS-113

JPL D-2560

Multimission Image Processing Laboratory Requirements Document

IDPS-109

JPL D-2719

see PD 630-530

JPL D-2769

see PD 630-300

JPL D-3198

JPL Standard Formatted Data Unit Description and Draft Standard

IDPS-102
IDPS-107
IDPS-109
IDPS-119
IDPS-123
IDPS-124
IDPS-135

JPL D-4037

***Space Flight Operations Center, Telemetry Input Subsystem,
Functional Requirement***

TPS-113

JPL D-4186

VICAR User's Manual, Issue 1

IDPS-109
IDPS-124
IDPS-135
SCI-001

JPL D-4421

see STIS0007-00-06

JPL D-4683

Standards for the Preparation and Interchange of Data Sets

SCI-001

MSDS-104

Average Orbital Elements

TPS-101

NAIF Document 167.0

Double Precision Array Files (DAF) Specification and User's Guide

see NAV-135

NAIF Document 168.0

S- and P-Kernel (SPK) Specification and User's Guide

see NAV-135

NAIF Document 169.0

SPACEIT Version 1.0 User's Guide

see NAV-135

(The) NAIF Ephemeris System

NAV-135

NAV-103

Navigation Constants File

NAV-134

REGRESS (Residual Data) File

NAV-135

**NAIF Ephemeris File (a collection of the following documents:
SFOC-2-DPS-CDB-Ephemeris, NAIF 167.0, 168.0, and 169.0)**

TPS-101 [SDPS-101 [IDPS-102] [IDPS-107]]

SCI-002

NAV-136

Average Orbital Elements

RES-104

OPS-6-8

(Probably a subsection of 820-13, Rev. A)

MON-105

PD 630-52

VRM Information System Plan

PD 630-204

PD 630-79

JPL D-2300

Planetary Constants and Models

IDPS-102

IDPS-107

IDPS-109

IDPS-119

IDPS-123

IDPS-124

IDPS-135

RES-104

SCI-001

SCI-002

SDPS-101

PD 630-100
VRM Spacecraft System Requirements
 PD 630-204

PD 630-104
Spacecraft System - Radar System IRD
 PD 630-204

PD 630-105
 see VRM-SE-004-014

PD 630-200
VRM Radar System Requirements
 PD 630-204

PD 630-202, Rev. B
Venus Radar Mapper Radar Data Processing Subsystem Functional Requirements
 IDPS-109

PD 630-204
MGN Mission Operations System, Radar System Interface Requirements Document
 SFOC-1-MHR-Mgn-SABHdr
 TPS-101

PD 630-258
SDPS Software Design Document, Offline Analysis
 SDPS-101

PD 630-300 JPL D-2769
Venus Radar Mapper, Mission Design Functional Requirements
 PD 630-204
 TPS-101
 TPS-140

PD 630-300, 2-100
MGN MOS Requirements, Uplink Process
 PD 630-204
 RES-104

PD 630-300, 2-200
MGN MOS Requirements, Downlink Process
 PD 630-204

PD 630-300, 3-200
MGN MOS Requirements, Ground Data System
 RES-104

PD 630-300, 4-130
MGN MOS Requirements, Radar System Engineering Team
 PD 630-204
 RES-101
 RES-104

PD 630-300, 4-170
MGN MOS Requirements, Radar Data Processing Team
 PD 630-204

PD 630-300, 4-230
MGN MOS Requirements, GDS Radar Engineering Subsystem
PD 630-204
RES-101
RES-104

PD 630-300-VRM-MOS-004-240
see MGN-MOS-4-240

PD 630-300, 4-251
MGN MOS Requirements, Telemetry Processing Subsystem Functional Requirements
PD 630-204
SES-115

PD 630-300, 4-270
MGN MOS Requirements, Radar Data Processing Subsystem
PD 630-204

PD 630-300-VRM-MOS-004-251
see PD 630-300, 4-251

PD 630-336
DPTRAJ and ODP (4 volumes)
NAV-103
NAV-134

PD 630-369
SDPS Functional Design Document
SDPS-101

PD 630-530 **JPL D-2719**
Magellan Altimeter Processing: Algorithms and Constants
IDPS-119

PD 630-610
see SES-112

RES-101 **SFOC-1-CDB-Mgn-Bandwidth**
Radar Processing Bandwidths File
TPS-101 [SDPS-101 [IDPS-102]]

RES-102
Radar Control Parameter File
PD 630-204

RES-104 **SFOC-1-CDB-MGN-Quaterni**
Mapping Quaternions Polynomial Coefficients File
TPS-101 [SDPS-101 [IDPS-102]]

SCDA 0007-00-03
Common Data Access Software Specification Document
NAV-135

SCDA 0007-00-04
see SCDA 0007-00-03

SCI-001 MIT-MGN-GxDR
MIT Global Image Data Records
 SCI-002

SCI-002 MIT-MGN-ARCDR
Altimetry and Radiometry Composite Data Record
 SCI-001

SDPS-101
Full-Resolution Basic Image Data Record
 IDPS-102
 IDPS-107
 IDPS-123

SDTS0008-00-02-05 SFOC-6-DTS-DTS-GlobalDa
Programmer's Note
 TPS-129

SES-112 SFOC-1-CDB-MGN-SCLKvSCET PD 630-610
Magellan SCLK/SCET Coefficients File
 TPS-101 [SDPS-101 [IDPS-102]]

SES-115 SFOC-1-DMD-Mgn-DECAL
MGN Decalibration File to DMD
 TPS-101 [SDPS-101 [IDPS-102]]

SFOC-TISMGN--9
 see MGN SRD WE2-03

SFOC-1-CDB-Mgn-Bandwidth
 see RES-101

SFOC-1-CDB-MGN-Quaterni
 see RES-104

SFOC-1-CDB-MGN-SCLKvSCET
 see SES-112

SFOC-1-CDB-Mgn-Timesfile
Processing Times File
 NAV-135

SFOC-1-DMD-Mgn-ChnlProc
Processing and Decom Map Data
 TPS-140

SFOC-1-DPS-MGN-EPHEMERIS
Spacecraft Ephemeris File
 NAV-135

SFOC-1-DMD-Mgn-DECAL
 see SES-115

SFOC-1-GIF-DSN-MgnGCFMon
 see MON-105

SFOC-1-GIF-DSN-MgnGIFMon
Magellan DSN Monitor Data
TPS-101

SFOC-1-MHR-Mgn-ArEngDR
see TPS-140

SFOC-1-MHR-Mgn-SABHdr
SAB Headers

SFOC-1-MHR-Mgn-SCIEDR
see TPS-101

SFOC-1-TIS-AnyDecomMap
title unknown
TPS-129

SFOC-1-TIS-Any-DecomRpt
Decommutation Report Form
TPS-101 [SDPS-101 [IDPS-102]]
TPS-140

SFOC-2-CDB-AnyAncillary
Ancillary Files
NAV-135

SFOC-2-CDB-ANY-Ancillary
title unknown (see also SFOC-2-CDB-AnyAncillary)
TPS-129
NAV-135

SFOC-2-CDB-ANY-Catalog
title unknown
TPS-129

SFOC-2-DPS-CDB-Ephemeris
Spacecraft and Planet Ephemeris, NAIF S and P Kernels
see NAV-135

SFOC-2-TIS-Any-DecomRpt
see TPS-129

SFOC-2-TIS-Any-MgnTelem
Magellan Telemetry Formats Generated by Telemetry Input Subsystem
TPS-101

SFOC-2-TIS-Any-Telem
Telemetry Minor Frame Formats from Telemetry Input Subsystem
TPS-101
TPS-113

SFOC-2-TIS-CDB-Telem
title unknown
TPS-113

SFOC-2-TIS-DMD-Telem
title unknown
TPS-113

SFOC-2-TIS-MPL-Telem
title unknown
TPS-113

SFOC-5-SYS-*DU-NJPL
see TPS-113

SFOC-5-TIS-*DU-MgnSFDU
see TPS-113

SFOC-5-TIS-*DU-SFDU
see TPS-113

SFOC-6-DTS-DTS-GlobalDa
see SDTS0008-00-02-05

SGS-107
Standard Sequence Data File
RES-104

SGS-108: Phase 1
Key Spacecraft Events Times File
TPS-101

STISMG06-02-00-09
see MGN SRD WE2-03

STISMG06-01-00-15
Trickle Telemetry Processing
TPS-113

STIS0004-02-01
see JPL D-4037

STIS0007-00-06 **JPL D-4421**
Spaceflight Operations Center, Telemetry Input Subsystem Software
Specification Document
TPS-129

TPS-101 **SFOC-1-MHR-Mgn-SCIEDR**
SAR and Altimeter EDR/TEDR Tapes
IDPS-119
SCI-002
SDPS-101
SFOC-1-MHR-Mgn-SABHdr
NAV-135

TPS-110
Engineering Telemetry File
SES-115

TPS-113

Magellan SFDU Formats

(includes 3 SFOC documents: SFOC-5-SYS-*DU-NJPL,
SFOC-5-TIS-*DU-MgnSFDU, and SFOC-5-TIS-*DU-SFDU)

RES-101

RES-104

SFOC-1-MHR-Mgn-SABHdr

TPS-101

TPS-129

TPS-140

TPS-129

SFOC-2-TIS-Any-DecomRpt

EDR Decom Map Report Form

SFOC-2-CDB-ANY-Ancillary

SFOC-2-CDB-ANY-CatalogDa

TPS-113

TPS-140

SFOC-1-MHR-Mgn-ArEngDR

Archival Engineering Data Record

TRK-101

820-13, Rev. A; TRK-2-18

Orbit Data File

TRK-103

820-13, Rev. A; TRK-2-23

Media Calibration Data

TRK-104

820-13, Rev. A; TRK-2-21

Timing and Polar Motion File

TRK-105

820-13, Rev. A; TRK-2-25

Archival Tracking Data File

UP 4144.31

Sperry Unisys 1100 Series Executive Vol 3

SES-112

USGS Bulletin 1532

Map Projections Used by the U.S. Geological Survey

IDPS-109

IDPS-124

IDPS-135

SCI-001

VAX Architecture Handbook

IDPS-102

IDPS-107

IDPS-109

IDPS-119

IDPS-124

IDPS-135

SDPS-101

VICAR User's Guide

see JPL D-4186

VICAR Run-Time Reference Manual, Rev. 1

IDPS-109

IDPS-124

IDPS-135

SCI-001

VRM-MOS-4-271

Magellan MOS Requirements, SAR Data Processing Subsystem (SDPS)

SDPS-101

VRM-SE018

Telemetry Calibration Report

SES-115

VRM-SE-001-002, VRM-2-270

Spacecraft System and Subsystem Design Book: Data System Bus

PD 630-204

VRM-SE-001-002, VRM-2-280

**Spacecraft System and Subsystem Design Book: Telemetry
Measurements and Data Formats**

PD 630-204

SES-115

TPS-113

TPS-113

TPS-101

VRM-SE-001-002, VRM-2-290

**Spacecraft System and Subsystem Design Book: Command Structures
and Assignments**

PD 630-204

TPS-140

VRM-SE-003-010

Spacecraft System - Radar System ICD

PD 630-204

VRM-SE-004-014

Spacecraft Flight System - MOS IRD

PD 630-204

VRM-2-280

see VRM-SE-001-002, VRM-2-280

820-13, Rev. A

DSN System Requirements, Detailed Interface Design

TPS-101

820-13, Rev. A; MON-5-12

see Mon-105

820-13, Rev. A; TLM 3-17

DSN Telemetry Interface with SFOC - Magellan

TPS-101

820-13, Rev. A; TLM-3-17
DSN Telemetry Interface with SFOC - Magellan
TPS-113

820-13, Rev. A; TRK-2-18
see TRK-101

820-13, Rev. A; TRK-2-21
see TRK-104

820-13, Rev. A; TRK-2-23
see TRK-103

820-13, Rev. A; TRK-2-25
see TRK-105

956572
JPL Magellan Radar System Full Scale Development Contract
PD 630-204

Appendix

Science Software Interface Specifications (references to Applicable Documents)

On the following pages data needed in compiling the Reverse Reference Listing have been abstracted. For each SIS of interest to science, the list of applicable documents has been reproduced. Where a specific file structure is relevant, that has been shown as well.

Pages are ordered by the Magellan SIS code.

SIS IDPS-102

Product: C-BIDR

Applicable Documents (AD):

- | | | |
|---|---------------------------|------------|
| 1 | SDPS-101 | |
| 2 | ANSI X3.54-1976 | |
| | ANSI X3.27-1978 | |
| 3 | JJPL0006-01-00 | |
| 4 | JPL D-3198 | |
| 5 | PD 630-79 | JPL D-2300 |
| 6 | VAX Architecture Handbook | |
| 7 | MOS-4-272 | JPL D-6425 |

Files:

F-BIDR tape in, C-BIDR tape out. Many files are simply copied over. Image files have been compressed from F-BIDR resolution.

- | | | |
|---------------------------------------|-------------------------------|-------------------------------|
| 1 | Volume Header File | Defined here |
| *** Start repeated set of files ***** | | |
| 2 | Orbit Header File | Copied from F-BIDR (see AD#1) |
| 3 | Data Quality File | Copied from F-BIDR (see AD#1) |
| 4 | Spacecraft Ephemeris File | Copied from F-BIDR (see AD#1) |
| 5 | SCLK/SCET Coefficients File | Copied from F-BIDR (see AD#1) |
| 6 | DSN Monitor File | Copied from F-BIDR (see AD#1) |
| 7 | MQPC File | Copied from F-BIDR (see AD#1) |
| 8 | Processing Bandwidths File | Copied from F-BIDR (see AD#1) |
| 9 | Decom/Decal File | Copied from F-BIDR (see AD#1) |
| 10 | Engineering Data File | Copied from F-BIDR (see AD#1) |
| 11 | SAB Header Records File | Copied from F-BIDR (see AD#1) |
| 12 | Per-orbit Parameters File | Copied from F-BIDR (see AD#1) |
| 13 | Oblique Sinusoidal Image Data | Defined here |
| 14 | Processing Parameters for 13 | Copied from F-BIDR (see AD#1) |
| 15 | Sinusoidal Image Data | Defined here |
| 16 | Processing Parameters for 15 | Copied from F-BIDR (see AD#1) |
| *** End repeated set of files ***** | | |
| n | Volume Trailer File | Defined here |

SIS: IDPS-107

Product: PIDR

Applicable Documents (AD):

1	SDPS-101	
2	VAX Architecture Handbook	
3	ANSI X3.54-1976	
	ANSI X3.27-1978	
4	JPL D-3198	
5	JJPL0006-01-00	
6	PD 630-79	JPL D-2300

Files:

F-BIDR tape in, PIDR tape out. Many files are simply copied over. Image files have been compressed from F-BIDR resolution.

1	Volume Header File	Defined here
*** Start repeated sets of files (up to 24 sets) *****		
2	Spacecraft Ephemeris File	Copied from F-BIDR (see AD#1)
3	Per-orbit Parameters File	Copied from F-BIDR (see AD#1)
4	Oblique Sinusoidal Image Data	Copied from F-BIDR (see AD#1)
5	Processing Parameters for 13	Copied from F-BIDR (see AD#1)
*** End repeated sets of files *****		
n	Volume Trailer File	Defined here

SIS: IDPS-109

Product: MIDR

Applicable Documents (AD):

1	PD 630-202, Rev. B	
2	JPL D-2560	
3	VICAR Run-Time Reference Manual, Rev. 1	
4	VICAR User's Guide, Issue 1	JPL D-4186
5	ANSI X3.54-1976	
6	ANSI X3.27-1978	
7	JJPL0006-01-00	
8	JPL D-3198	
9	VAX Architecture Handbook	
10	USGS Bulletin 1532	
11	PD 630-79	JPL D-2300

Files:

F-BIDR or C-BIDR tapes in; F-MIDR, C1-MIDR, C2-MIDR, or C3-MIDR tape out. Image data are stored on output tape as subframes, one subframe per tape file.

NB: The Seam Locations File does not appear on C2-MIDR and C3-MIDR tapes.

1	SFDU Header File	Defined here
2	Tape Header File	Defined here
3-58	Subframes #1-56	Defined here
59-114	Subframes #1-56	Defined here
115	Seam Locations File	Defined here
116	SFDU Trailer File	Defined here

SIS: IDPS-119

Product: BADR

Applicable Documents (AD):

1	MOS-4-272	
2	ANSI X3.54-1976	
3	ANSI X3.27-1978	
4	JJPL0006-01-00	
5	JPL D-3198	
6	VAX Architecture Handbook	
7	PD 630-79	JPL D-2300
8	TPS-101	SFOC-1-MHR-SCIEDR
9	PD 630-530	JPL D-2719

Files:

Up to 40 ALT-EDR tapes in; BADR tape out.

1	SFDU Header File	Defined here
2-41	Altimetry Files	Defined here
42	SFDU Trailer File	Defined here

SIS: IDPS-123

Product: BRDR

Applicable Documents (AD):

1	SDPS-101	
2	ANSI X3.54-1976	
	ANSI X3.27-1978	
3	JPL D-3198	
4	JJPL0006-01-00	
5	PD 630-79	JPL D-2300

Files:

UP to 232 F-BIDR tapes in, BRDR tape out.

1	Volume Header File	Defined here
2-233	Processed Radiometer Data	Copied from F-BIDR (see AD#1)
234	Cold Sky Calibrations	Copied from F-BIDR (see AD#1)
235	Volume Trailer File	Defined here

SIS: IDPS-124

Product: GRDR

Applicable Documents (AD):

1	MOS-4-272	
2	VICAR Run-Time Reference Manual, Rev. 1	
3	VICAR User's Guide, Issue 1	JPL D-4186
4	ANSI X3.54-1976	
5	ANSI X3.27-1978	
6	JJPL0006-01-00	
7	JPL D-3198	
8	VAX Architecture Handbook	
9	USGS Bulletin 1532	
10	PD 630-79	JPL D-2300
11	IDPS-123	

Files:

BRDR tape in; GRDR tape out.

1	Header File	Defined here
2	Data Header File	Defined here
3	Black Body Temperature	See AD#11 for BBT definition
4	Equivalent Surface Brightness	See AD#11 for ESB definition
5	Trailer File	Defined here

SIS: IDPS-135

Product: GADR

Applicable Documents (AD):

1	MOS-4-272	
2	VICAR Run-Time Reference Manual, Rev. 1	
3	VICAR User's Guide, Issue 1	JPL D-4186
4	ANSI X3.54-1976	
5	ANSI X3.27-1978	
6	JJPL0006-01-00	
7	JPL D-3198	
8	VAX Architecture Handbook	
9	USGS Bulletin 1532	
10	PD 630-79	JPL D-2300
11	IDPS-119	

Files:

BADR tapes in; GADR tape out.

1	Header File	Defined here
2	Data Header File	Defined here
3	Global Terrain Elevation Image	Defined here
4	Trailer File	Defined here

SIS: MON-105 820-13, Rev. A; MON-5-12,
SFOC-1-GIF-DSN-MgnGCFMon
Product: DSN Monitor Data File

Applicable Documents (AD):

1 Module OPS-6-8

Note: Any early version of this SIS was also labeled SFOC-1-GIF-DSN-MgnGCFMon

SIS: NAV-103
Product: Navigation Constants File

Applicable Documents (AD):

1 PD 630-336, Volumes 1-4

SIS: NAV-134
Product: REGRES (Residual Data) File

Applicable Documents (AD):

1 DPTRAJ and ODP (PD 630-336) (4 volumes)

SIS: NAV-135

Product: NAIF Ephemeris File

Note: This document is a collection of 4 lower-level SIS documents:

SFOC-2-DPS-CDB-Ephemeris
NAIF-167.0
NAIF-168.0
NAIF-169.0

Applicable Documents (AD):

1	SCDA 0007-00-04	
2	DDN Protocol Handbook	
3	JJPL0006-01-00	
4a	SFOC-2-CDB-Any-Ancillary	
4b	SFOC-1-MHR-Mgn-SCIEDR	
4c	NAV-135	SFOC-1-DPS-MGN-Ephemeris
4d	SFOC-1-CDB-MGN-TimesFile	
4e	SFOC-1-MHR-MGN-SCIEDR	

SIS: PD 630-204

Product: MOS/Radar System IRD

Applicable Documents (AD):

1a	PD 630-52
1b	PD 630-100
1c	PD 630-104
1d	PD 630-200
1e	PD 630-300
1f	RES-102
2a	VRM-SE-004-014
2b	VRM-SE-003-010
2c	VRM-SE-001-002
3a	956572
3b	DS 32466-101
3c	DS 32466-111
3d	DS 32466-121
3e	DS 32466-141
3f	HS 513-088

SIS: RES-101
Product: Processing Bandwidths File

SFOC-1-CDB-Mgn-Bandwidth

Applicable Documents (AD):

- 1 PD 630-300, 4-130
- 2 PD 630-300, 4-230
- 3 DS 32466-402
- 4 HS 513-034E
- 5 JJPL0006-01-00
- 6 TPS-113
- 7 JJPL0006-00-02

SFOC-5-SYS-*DU-NJPL

SIS: RES-104
Product: MQPC File

SFOC-1-CDB-MGN-Quaterni

Applicable Documents (AD):

- 1a PD 630-300, 2-100
- 1b PD 630-300, 3-200
- 1c PD 630-300, 4-130
- 1d PD 630-300, 4-230
- 2 NAV-136
- 3 SGS-107
- 4 DS 32466-402
- 5 PD 630-79
- 6 HS 513-034E
- 7 JJPL0006-01-00
- 8 TPS-113

JPL D-2300

SFOC-5-SYS-*DU-NJPL

SIS: SCI-001

MIT-MGN-GxDR

Products:

GTDR	Global Topographic Data Record
GREDR	Global Reflectivity Data Record
GSDR	Global Slope Data Record
GEDR	Global Emissivity Data Record

Applicable Documents (AD):

1	ANSI X3.27-1978	
2	JJPL0006-01-00	
3	MIT-MGN-SDMP	
4	MIT-MGN-SDMP	
5	SCI-002	MIT-MGN-ARCDR
6	JPL D-4311	
7	JPL D-4186	
8	USGS GSB-1532	
9	PD 630-79	JPL D-2300
10	JPL D-4683	

Files:

ARCDR tapes in, GxDR tapes out, subsequently copied to a single CD-ROM containing all 4 data types as VICAR-2 image frames in 4 cartographic projections. GTDR includes a 5th image of radius error.

1	Volume Header File	Defined here
2	Sinusoidal Header File	Defined here
3-34	Sinusoidal Image Frames	Defined Here
35	North Polar Header File	Defined Here
36-39	Stereographic Image Files	Defined Here
40	South Polar Header File	Defined Here
41-44	Stereographic Image Files	Defined Here
45	Mercator Header File	Defined Here
46-77	Mercator Image Frames	Defined Here

*** For GTDR only *****

78	Error Header File	Defined Here
79-110	Error Image Frames	Defined Here

*** End of GTDR only *****

78		Defined here
or	Volume Trailer File	
111		

SIS: SCI-002 MIT-MGN-ARCDR

Product: ARCDR

Applicable Documents (AD):

- | | | |
|----|--------------------|--------------------------|
| 1 | ANSI X3.27-1978 | |
| 2 | JJPL0006-01-00 | |
| 3 | TPS-101 | SFOC-1-MHR-MGN-SCIHDR |
| 4 | NAV-135 | SFOC-2-DPS-CDB-Ephemeris |
| 5 | IDPS-102 | |
| 6 | MIT-MGN-SDMP | |
| 7 | MIT-MGN-SDD | |
| 8 | SCI-001 | MIT-MGN-GxDR |
| 9 | PD 630-79 | JPL D-2300 |
| 10 | USGS Bulletin 1532 | |
| 11 | MIT-MGN-ERR | |

Files:

ALT-EDR tapes in, ARCDR tape out, subsequently copied to CD-ROM. SPK ephemeris files are simply copied over. The other files are the result of processing at MIT.

- | | | |
|--|---------------------------|---|
| 1 | Volume Header File | Defined here |
| *** Start repeated sets of files (up to 60 sets) ***** | | |
| 2 | Orbit Header File | Defined here |
| 3 | Spacecraft Ephemeris File | Copied from ALT-EDR
(see AD#3, AD#4) |
| 4 | Altimetry Data File | Defined here |
| 5 | Radiometry Data File | Defined here |
| *** End repeated sets of files ***** | | |
| n | Volume Trailer File | Defined here |

SIS: SDPS-101

Product: F-BIDR

Applicable Documents (AD):

1	TPS-101	SFOC-1-MHR-MGN-SCIEDR
2	ANSI X3.54-1976	
	ANSI X3.27-1978	
3	VAX Architecture Handbook	
4	JJPL0006-01-00	
5	VRM-MOS-4-271	
6	PD 630-79	JPL D-2300
7	PD 630-258	
8	PD 630-369	
9	MGN-SFOP-10-220, SDPT-SP-12	

Files:

SAR-EDR tape in, F-BIDR tape out. Many files are simply copied over. Image and radiometry files represent results of processing. Parameter and processing monitor files provide view into processing.

1	BIDR Header File	Defined here
2	Orbit Header File	Copied from SAR-EDR (see AD#1)
3	Data Quality File	Copied from SAR-EDR (see AD#1)
4	Spacecraft Ephemeris File	Copied from SAR-EDR (see AD#1)
5	SCLK/SCET Coefficients File	Copied from SAR-EDR (see AD#1)
6	DSN Monitor File	Copied from SAR-EDR (see AD#1)
7	MQPC File	Copied from SAR-EDR (see AD#1)
8	Processing Bandwidths File	Copied from SAR-EDR (see AD#1)
9	Decom/Decal File	Copied from SAR-EDR (see AD#1)
10	Engineering Data File	Copied from SAR-EDR (see AD#1)
11	SAR Header Records File	Copied from SAR-EDR (see AD#1)
12	Per-orbit Parameters File	Defined here
13	Oblique Sinusoidal Image Data	Defined here
14	Processing Parameters for 13	Defined here
15	Sinusoidal Image Data	Defined here
16	Processing Parameters for 15	Defined here
17	Processed Radiometer Data	Format defined here Algorithms in AD#5
18	Cold Sky Calibrations	Defined here
19	Processing Monitor Results	Defined here
20	BIDR Trailer File	Defined here

SIS: SES-112 SFOC-1-CDB-MGN-SCLKvSCET

Product: SCLK/SCET Coefficient File

Applicable Documents (AD):

- 1 MGN-MOS-4-240
- 2 UP 4144.31

SIS: SES-115 SFOC-1-DMD-Mgn-DECAL

Product: Telemetry Decommuation/Decalibration Data

Applicable Documents (AD):

- 1 PD 630-300-VRM-MOS-004-240
- 2 PD 630-300-VRM-MOS-004-251
- 3 VRM-SE018
- 4 TPS-110
- 5 VRM-SE-001-002
- 6 DMD SDD

SIS: SFOC-1-MHR-Mgn-SABHdr

Product: SAB Headers

Applicable Documents (AD):

- 1 TPS-113 SFOC-5-TIS-*DU-Mgn.SFDU
- 2 TPS-113 SFOC-5-TIS-*DU-SFDU
- 3 SMHR0007-00-03-00 MHR SSD
- 4 TPS-113 SFOC-5-SYS-*DU-NJPL
- 5 PD 630-204
- 6 TPS-101 SFOC-1-MHR-Mgn-SCIEDR

SIS: TPS-101 SFOC-1-MHR-Mgn-SCIEDR

Product: ALT-EDR or SAR-EDR

Applicable Documents (AD):

1	PD 630-300	
2	820-13, Rev. A	
3	ANSI X3.27-1978	
4	MSDS-104	
5	SGS-108: Phase 1	
6	RES-101	SFOC-1-CDB-Mgn-Bandwidth
7	SES-112	SFOC-1-CDB-MGN-SCLKvSCET
8	RES-104	SFOC-1-CDB-MGN-Quaterni
9	TPS-129	SFOC-1-TIS-Any-DecomRpt
10	SES-115	SFOC-1-DMD-Mgn-DECAL
11	NAV-135	SFOC-2-DPS-CDB-Ephemeris
12	SFOC-5-TIS-Any-MgnTelem	
13	SFOC-5-TIS-Any-Telem	
14	TPS-113	SFOC-5-SYS-*DU-NJPL
15	TPS-113	SFOC-5-TIS-*DU-MgnSFDU
16	TPS-113	SFOC-5-TIS-*DU-SFDU
17	VRM 2-280	
18	MON-105	SFOC-1-GIF-DSN-MgnGIFMon
19	PD 630-204	
20	820-13, Module TLM 3-17	

Files:

ODR tape(s) plus many disk files in; ALT-EDR or SAR-EDR tape out. Disk files are reformatted as a result of the change in media; content is as given in the Applicable Document (AD).

ALT-EDR contains data from up to 7 orbits (in repeating sets of files as per below); SAR-EDR contains data from only one orbit. ALT-EDR does not have Processing Bandwidths File (File 8 below).

1	Volume Header File	Defined here
*** Start repeating sets of files (ALT-EDR only) *****		
2	Orbit Header Record File	Defined here
3	Data Quality Summary File	Defined here
4	Spacecraft Ephemeris File	AD#11
5	SCLK/SCET Coefficients File	AD#7, 11
6	DSN Monitor File	AD#16, 18
7	MQPC File	AD#8, 14
8	Processing Bandwidths File	AD#6, 14
9	Decom/Decal File	AD#9, 10
10	Engineering Data File	AD#14, 15, 16, 17
11	SAB Header Records File	AD#14, 15, 16, 17, 19
12	ALT or SAR Data File	AD#15, 16, 19
*** End repeating sets of files (ALT-EDR only) *****		
n	Volume Trailer File	Defined here

SIS: TPS-113

Product: SFDU Header Reference

Note: This is a set of 3 subsystem interface specifications:

SFOC-5-SYS-*DU-NJPL	NJPL SFDU Global Definitions
SFOC-5-TIS-*DU-MgnSFDU	SFDUs Generated from TIS for Magellan
SFOC-5-TIS-*DU-SFDU	SFDUs Generated/Received by TIS

Applicable Documents (AD):

SFOC-5-SYS-*DU-NJPL
1 JJPL0006-01-00

SFOC-5-TIS-*DU-MgnSFDU
1 MGN SRD WE2-03 STISMG06-02-00-09
2 SFOC-2-TIS-DMD-Telem
3 SFOC-2-TIS-CDB-Telem
4 SFOC-2-TIS-MPL-Telem
7 STISMG06-01-00-15
8 VRM 2-280

SFOC-5-TIS-*DU-SFDU:
1 VRM 2-280
2a 820-13, Rev. A; TLM-3-17
2b 820-13, Rev. A; MON-5-12
3 MO 642-530 JPL D-1672
5 JPL D-4037
6 MGN SRD WE2-03 SFOC-TISMGN-09

SIS: TPS-129

SFOC-1-TIS-Any-DecomRpt

Product: EDR Decom Map Report Form

Applicable Documents (AD):

1a	TPS-113	SFOC-5-TIS-*DU-SFDU
1b	TPS-129	SFOC-1-TIS-AnyDecomMap
1c	SFOC-2-CDB-ANY-Ancillary	
1d	SFOC-2-CDB-ANY-Catalog	
1e	TPS-113	SFOC-5-SYS-*DU-NJPL
2	STIS0007-00-06	JPL D-4421
3	SDTS0008-00-02-05	SFOC-6-DTS-DTS-GlobalDa

SIS: TPS-140 SFOC-1-MHR-Mgn-ArEngDR

Product: AEDR

Applicable Documents (AD):

- 1 ANSI X3.27-1978
- 2 820-13, Rev. A; MON-5-12
- 3 PD 630-300 JPL D-2769
- 4 VRM-2-280
- 5a TPS-129 SFOC-1-TIS-Any-DecomRpt
- 5b TPS-113 SFOC-5-TIS-*DU-MgnSFDU
- 5c TPS-113 SFOC-5-TIS-*DU-SFDU
- 5d SFOC-1-DMD-Mgn-ChnlProc
- 5e TPS-113 SFOC-5-SYS-*DU-NJPL

Files:

Engineering and Monitor files from CDB are input; AEDR tape is output. Approximately 72 hrs of spacecraft time per AEDR tape.

- 1 Volume Header File Defined here
- *** Start repeating set of files *****
- 2 Decom Map File
- 3 Decal Data File
- 4 Engineering Minor Frames
- 5 Monitor 5-15 File
- *** End repeating set of files *****
- n Volume Trailer File Defined here

SIS: TRK-101 820-13, Rev.A; TRK-2-18
Product: Orbit Data File
Applicable Documents (AD):
none

SIS: TRK-103 820-13, Rev. A; TRK-2-23
Product: Media Calibration Data
Applicable Documents (AD):
none

SIS: TRK-104 820-13, Rev. A; TRK-2-21
Product: Timing and Polar Motion File
Applicable Documents (AD):
none

SIS: TRK-105 820-13, Rev. A; TRK-2-25
Product: Archival Tracking Data File
Applicable Documents (AD):
none

5

MIDR Browse Images

*E*ach CD-ROM contains 10 MIDRs. For each of the first 69 CD-ROMs produced, Browse Brochures were created. These images serve as a hardcopy index to the CD-ROMs and can be used to quickly locate a particular region of interest. The following pages contain the Browse Brochures for the first 69 CD-ROMs. Each image is annotated with the Magellan

CD-ROM identification number and version, the production date, and the type of MIDR on the CD-ROM (F-MIDR or *Cn*-MIDR) — as well as the MIDR identification numbers for the individual products. Tables 7.6–7.11 should be used to locate images on the CD-ROMs beyond MIDR CD-ROM 69.

1) 75N332



2) 60N334

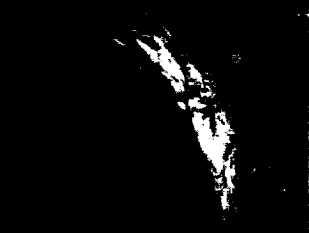

3) 65N330

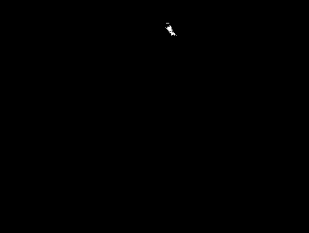

4) 05S335



5) 20N334

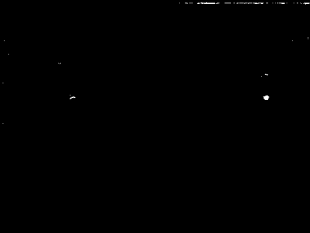

6) 27S339

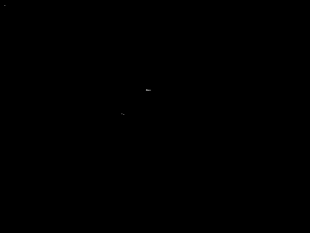

7) 30N334

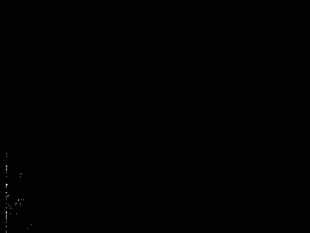

8) 40S342



9) 50S345

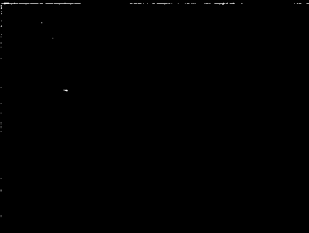

10) 55N337

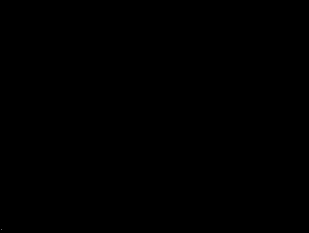

MAGELLAN
MIDRCD.001;2
TEN TEST F-MIDR'S

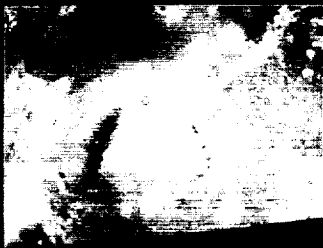

(1) 00N335



(2) 00N352

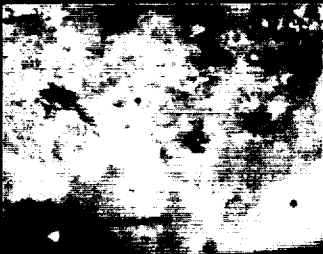

(3) 15N335



(4) 15N332

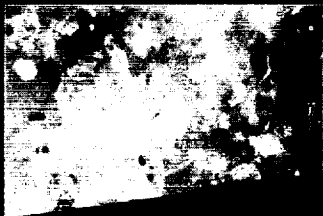

(5) 15S335



(6) 15S352

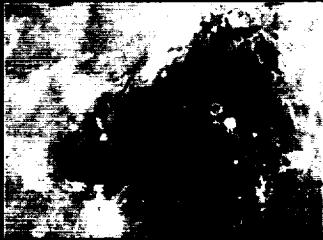

(7) 30N333



(8) 30S333



(9) 30S351



(10) 45S350

MAGELLAN
MIDRCD.002;1
TEN C1 - MIDR'S
August 1991



(1) 15N340



(5) 75N332

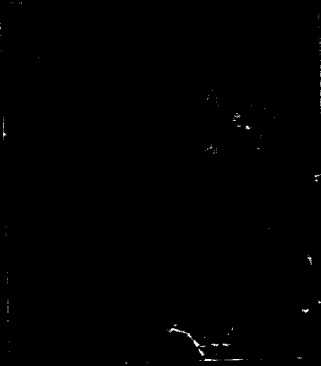

(2) 55N337



(6) 25S345



(3) 60N334



(7) 45S349

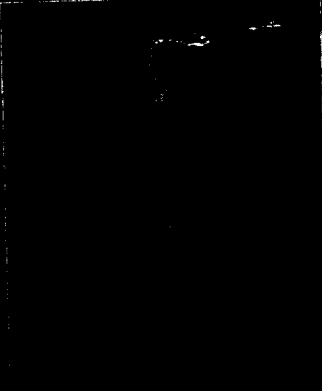

(10) 65S354

MAGELLAN
MIDRCD.003;1
TEN C1 - MIDR'S
August 1991



(4) 65N330

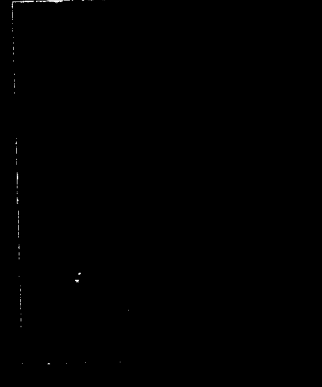

(9) 60S355

(8) 50S345

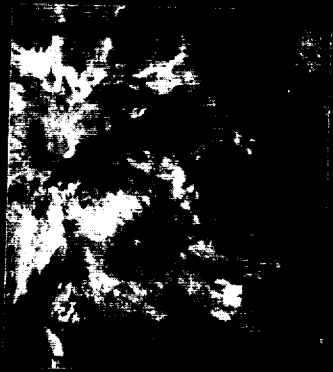

(1) 20N351



(2) 25N345



(3) 25N351



(4) 40S349



(5) 50S356



(6) 55N346

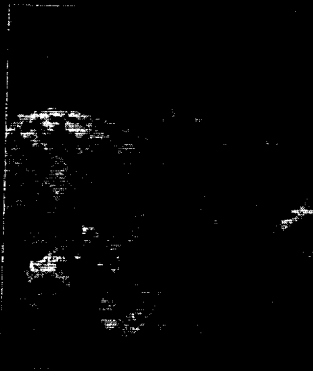

(7) 55S355



(8) 60N344



(9) 65N342



(10) 70N339

MAGELLAN
MIDRCD.004;1
TEN F-MIDR'S
August 1991



(1) 00N357



(2) 05N357

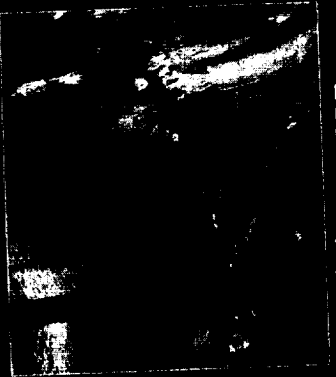

(3) 05S357

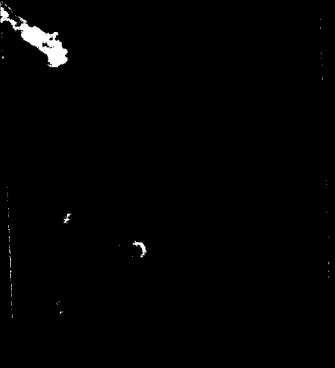

(4) 20N357

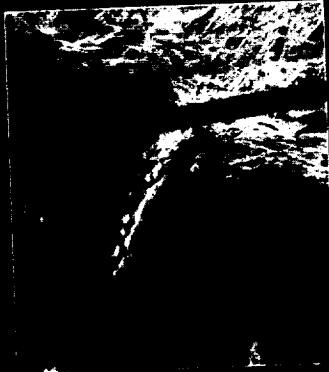

(5) 20S357

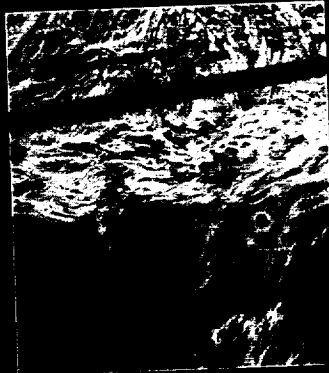

(6) 25S357



(7) 30S357



(8) 35S357

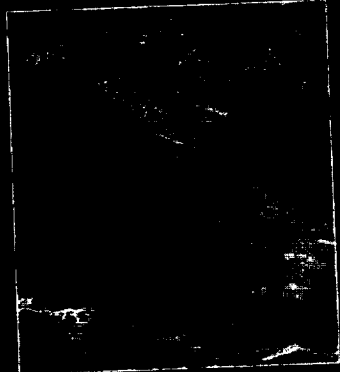

(10) 65S005



(9) 60S005

MAGELLAN
MIDRCD.005;1
TEN F-MIDR'S
August 1991



(1) 20S003



(3) 25S003



(4) 30S003

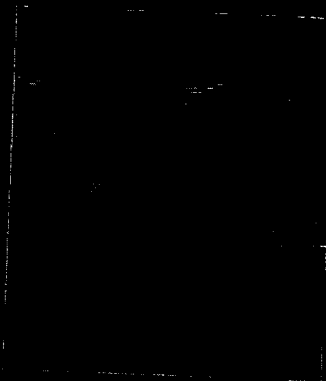

(5) 35S003



(6) 40S004



(7) 50N356



(9) 65N354

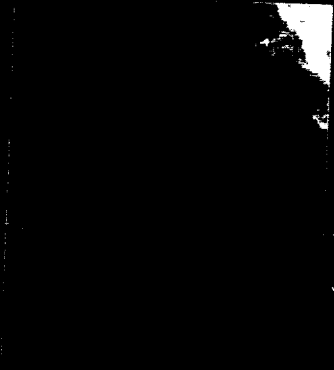

(10) 70N353

MAGELLAN
MIDRCD.006;1
TEN F-MIDR'S
August 1991

(8) 60N355

(1) 75N351

(2) 70N007

(3) 65N018

(5) 45N004

(6) 40N018

(7) 25N003

(9) 25S009

(10) 30S009

MAGELLAN
MIDRCD.007;1
TEN F-MIDR'S
September 1991

010000Z

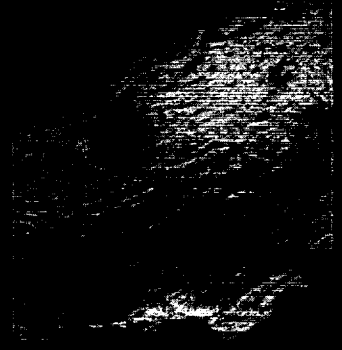

(1) 65N006 (2) 60N026 (3) 60N005 (4) 55N013

(5) 50N021 (6) 40N025 (7) 10N020 (8) 05N018

MAGELLAN
MIDRCD.008;1
TEN F-MIDR'S
September 1991

(9) 60S016 (10) 05S082

(1) 05N070

(2) 05N065

(3) 00N076



(5) 00N065

(6) 10S082

(7) 10S076



(9) 05S076

(10) 05S070

MAGELLAN
MIDRCD.009;1
TEN F-MIDR'S
September 1991

(1) 10N014



(5) 00N082



(9) 05S087

(2) 05N087



(6) 30S022

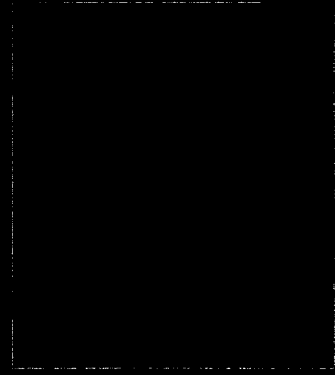

(10) 05S065

(3) 05N082



(7) 10S087

MAGELLAN
MIDRCD.010;1
TEN F-MIDR'S
September 1991

(8) 10S065

(4) 00N087

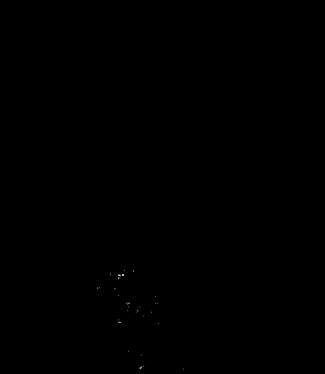



(1) 55N060

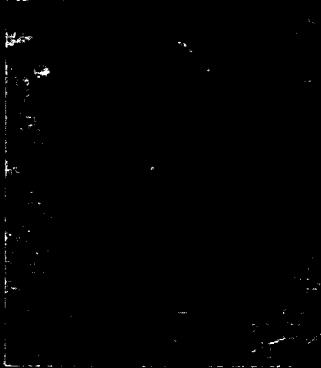

(2) 45N080



(3) 45N019



(4) 40N088



(5) 35N077



(6) 15N020



(7) 15N014

(8) 50S088



(9) 35S090

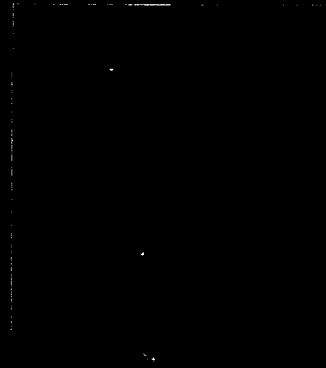

(10) 35S083

MAGELLAN
MIDRCD.011;1
TEN F-MIDR'S
September 1991



(1) 60N014



(2) 45N350

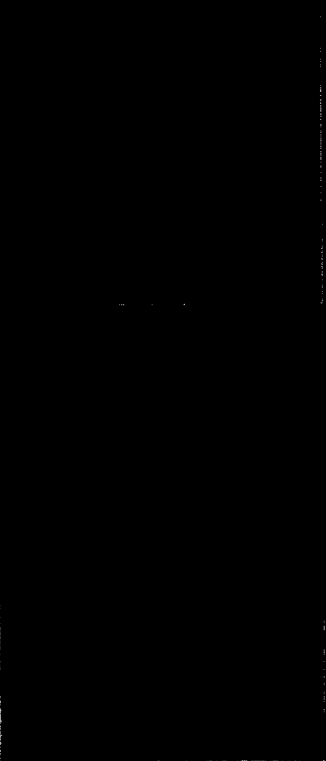

(3) 45N032
(4) 30N351



(5) 30N027

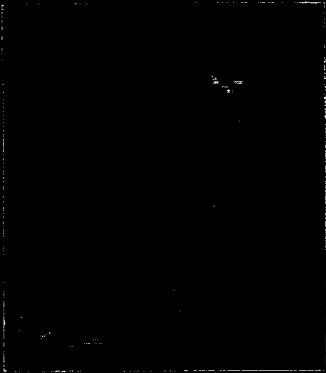

(6) 30N009

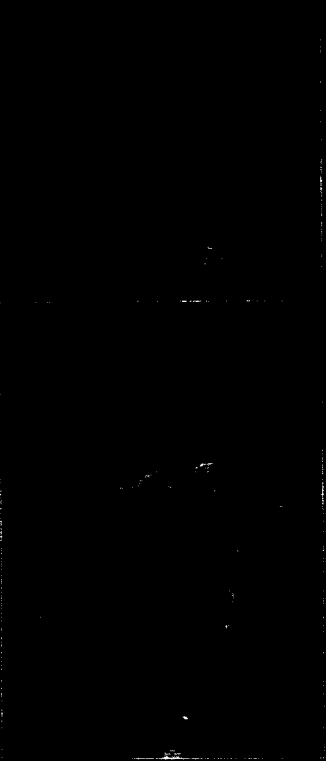

(7) 15N026
(8) 00N026



(9) 45S011



(10) 15S026

MAGELLAN
MIDRCD.012;1
TEN C1-MIDR'S
September 1991

(1) 65N126

(2) 50N054

(3) 30N123

(4) 15N111

(5) 10N065

(6) 40S138

(7) 35S130

(8) 30S129

(9) 25S131

(10) 25S082

MAGELLAN
MIDRCD.013;1
TEN F-MIDR'S
September 1991

(1) 75N338

(2) 60N347

(3) 45N011

(4) 15N009

(5) 00N060

(6) 00N009

(7) 45S032

(8) 30S027

(9) 30S009

(10) 15S009

MAGELLAN
MIDRCD.01 4;1
TEN C1 -MIDR'S
September 1991

(1) 65N102

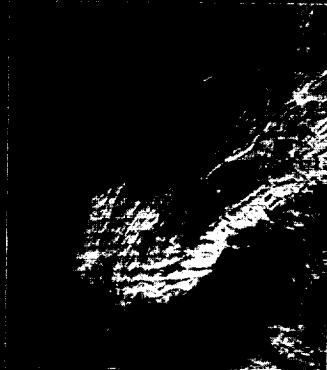

(5) 05N098

(2) 20N097

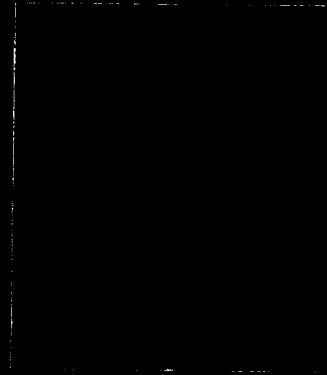

(6) 30S136

(3) 20N080



(7) 10S132

(4) 15N129

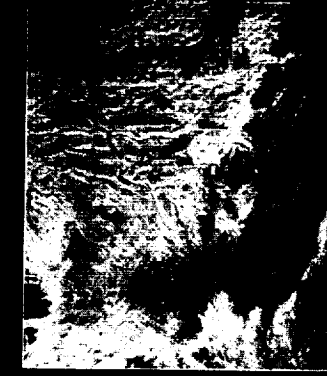

(8) 10S098



(9) 05S132



(10) 05S098

MAGELLAN
MIDRCD.015;1
TEN F-MIDR'S
September 1991

(1) 75N029

(2) 60N042

(3) 45N053

(4) 30N063

(5) 15N060

(6) 00N077

(7) 60S014

(8) 45S074

(9) 30S063

(10) 15S060

MAGELLAN
MIDRCD.016;1
TEN C1-MIDR'S
September 1991



(1) 20S121



(2) 00N132



(3) 05N132

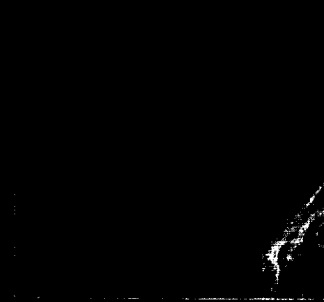

(4) 10N098



(5) 10N132

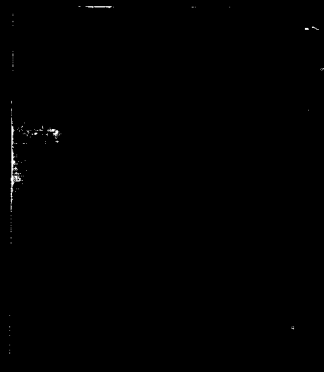

(6) 20N145



(7) 25N119

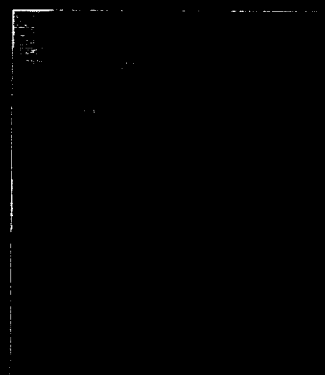

(9) 45N126



(10) 65N114

MAGELLAN
MIDRCD.017;1
TEN F-MIDR'S
September 1991

(8) 45N119

(1) 60N312

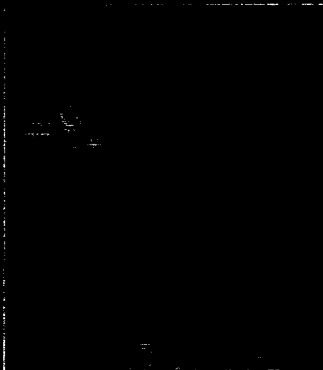

(5) 45S019



(9) 20S145

(2) 60N111

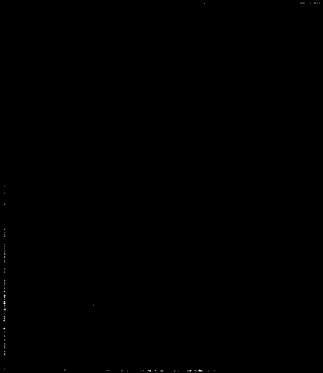

(6) 40S145



(10) 15S123

(3) 55S014

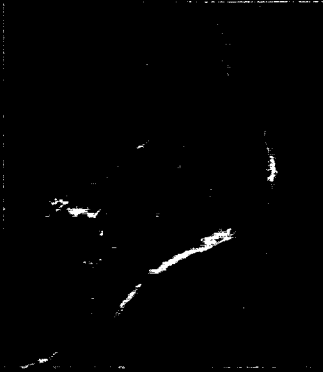

(7) 40S131

MAGELLAN
MIDRCD.018;1
TEN F-MIDR'S
September 1991

(4) 50S013

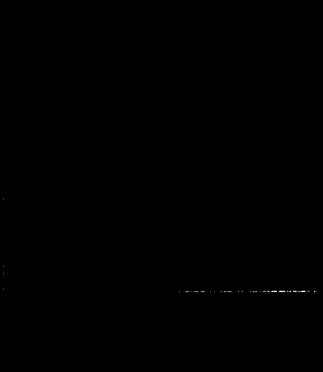

(8) 40S074

(1) 60N070

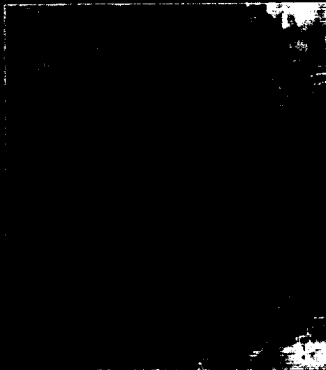

(5) 00N112



(9) 15S095

(2) 15N095



(6) 00N095

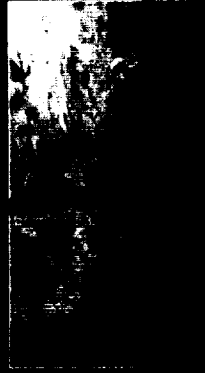

(10) 15S077

(3) 15N077

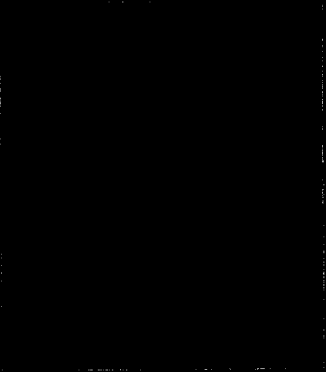

(7) 45S096



MAGELLAN
MIDRCD.019;1
TEN C1-MIDR'S
September 1991

(4) 00N129



(8) 15S129



(1) 45N096

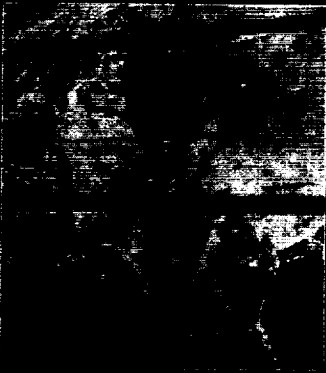

(2) 45N074

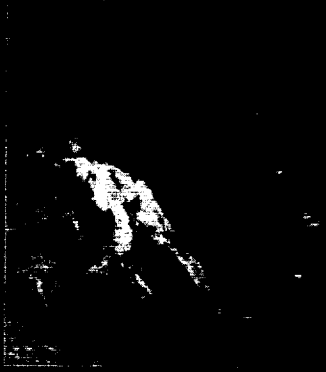

(3) 30N099



(4) 30N081



(5) 15N129

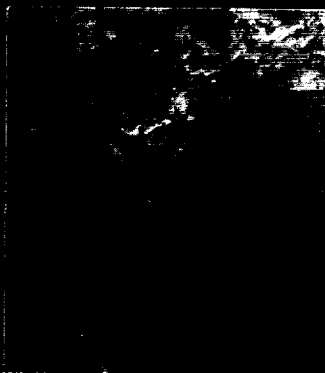

(6) 15N112



(7) 60S042



(8) 30S099



(9) 30S081



(10) 15S112

MAGELLAN
MIDRCD.020;1
TEN C1-MIDR'S
September 1991

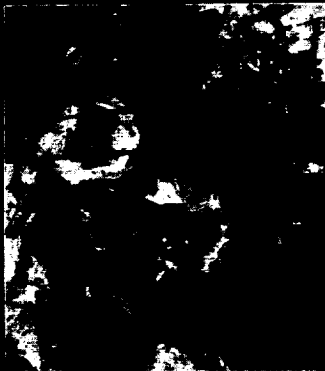

(1) 60N125



(2) 60N097



(3) 45N138



(4) 45N117



(5) 30N117



(6) 60S070



(7) 45S138



(8) 45S117

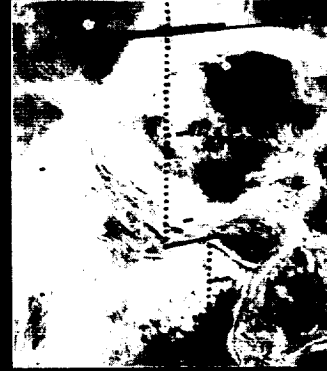

(9) 30S135



(10) 30S117

MAGELLAN
MIDRCD.021;1
TEN C1-MIDR'S
September 1991

(1) 60S097

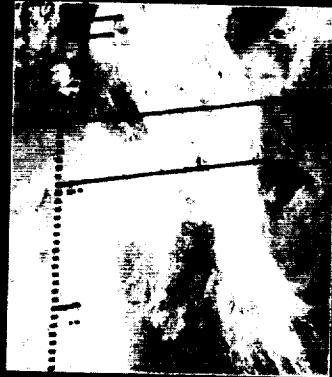

(5) 15S146



(9) 15N146

(2) 60S125

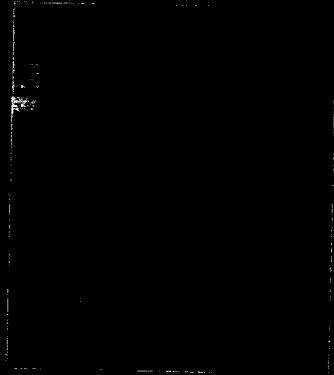

(6) 45S159

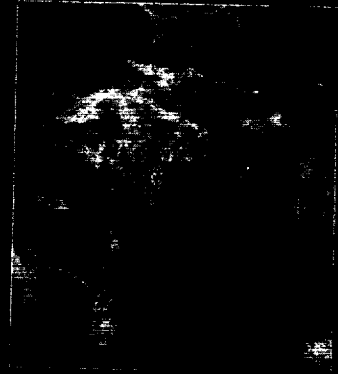

(10) 30N153

(3) 75N074



(7) 00N146

MAGELLAN
MIDRCD.022;1
TEN C1-MIDR'S
September 1991

(4) 60S153



(8) 30S153

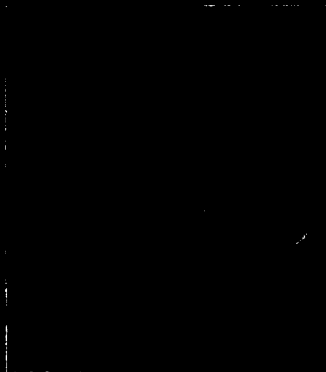

(1) 55N152

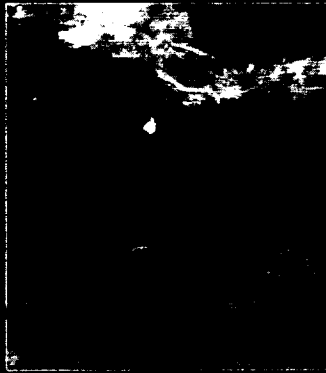

(2) 05N177



(3) 10S155



(4) 15S157



(5) 15S163



(6) 20S156



(7) 25S156



(8) 25S162



(9) 30S161

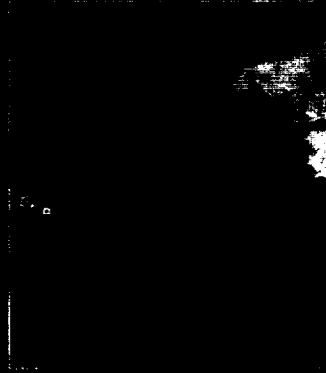

(10) 35S163

MAGELLAN
MIDRCD.023;1
TEN F-MIDR'S
December 1991



(1) 20N192



(2) 10N194

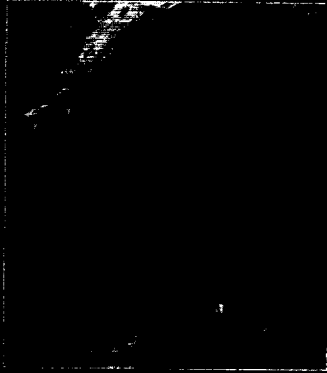

(3) 10N177

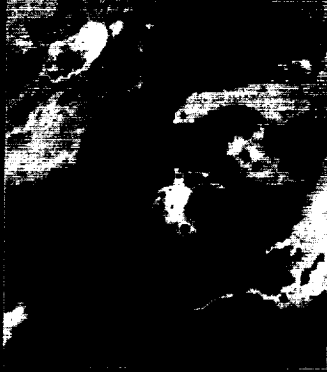

(4) 05N194

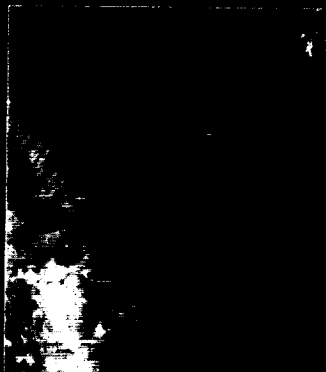

(5) 05N188



(6) 00N194

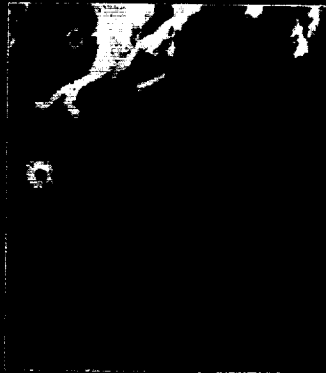

(7) 00N189



(8) 05S177



(9) 10S177



(10) 20S162

MAGELLAN
MIDRCD.024;1
TEN F-MIDR'S
December 1991



(1) 20N198



(2) 20N186



(3) 15N197



(4) 15N191

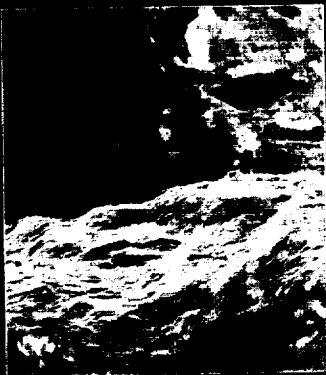

(5) 10N200



(6) 10N188

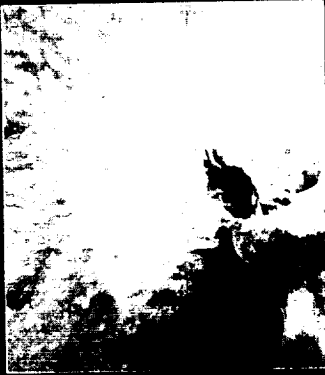

(7) 05N200



(8) 00N200



(10) 15S180



(9) 10S188

MAGELLAN
MIDRCD.025;1
TEN F-MIDR'S
December 1991

(1) 65N162



(5) 25N186

(2) 60N164



(6) 05S183

(3) 50N147



(7) 10S183

(4) 45N195



(8) 20S180

MAGELLAN
MIDRCD.026;1
TEN F-MIDR'S
December 1991

(9) 30S205

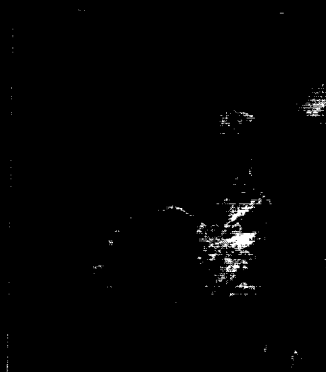

(10) 60S207



(4) 45N211



(8) 00N217

(3) 50N172



(7) 05N205

(2) 50N197



(6) 25N211



(10) 10S200

(1) 65N186



(5) 35N197

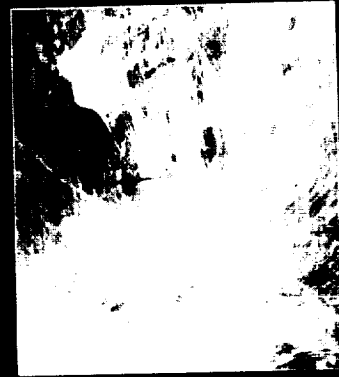

(9) 00N205

MAGELLAN
MIDRCD.027;1
TEN F-MIDR'S
December 1991

(1) 65N198

(2) 60N207

(3) 55N208

(4) 50N205



(5) 40N194



(6) 20N204



(7) 05S205



(8) 05S217

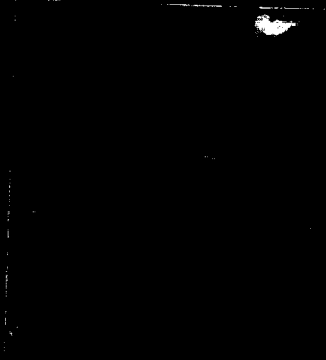

(9) 30S212

(10) 45S211

MAGELLAN
MIDRCD.028;1
TEN F-MIDR'S
December 1991



(1) 10N211



(2) 05N217



(3) 05S211

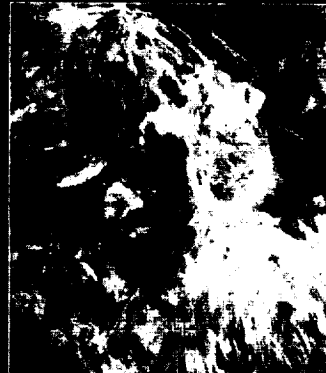

(4) 10S211



(5) 15S214



(6) 20S204



(7) 20S210



(8) 20S221

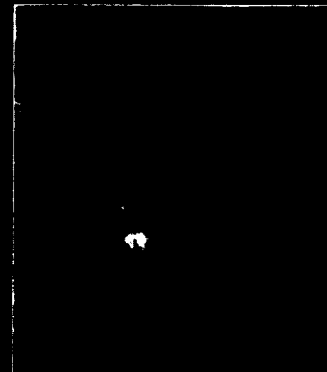

(9) 40S222



(10) 45S218

MAGELLAN
MIDRCD.029;1
TEN F-MIDR'S
December 1991



(1) C1-75N119

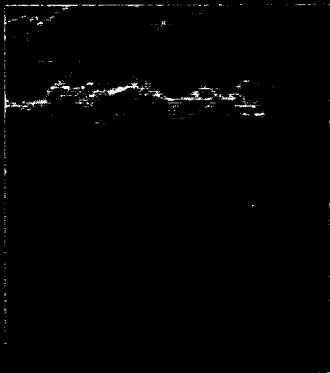

(2) C1-60N180

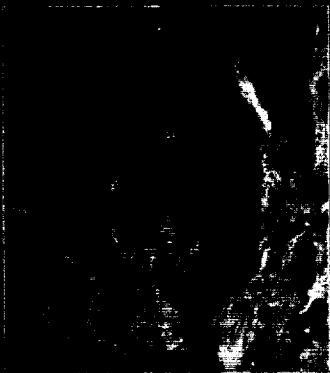

(3) C1-45N180

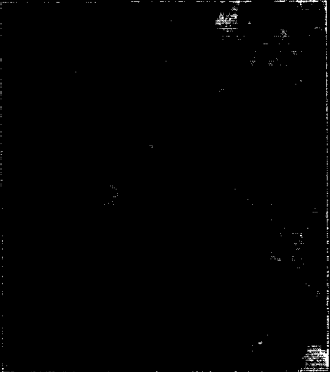

(4) C1-45N159

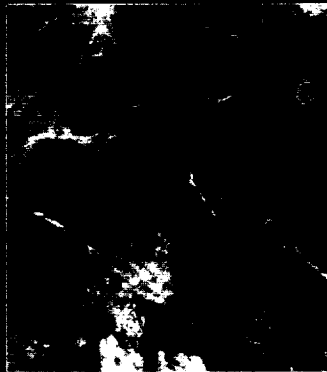

(5) C1-30N135



(6) C1-15N180



(7) C1-00N180



(8) C2-00N080



(9) C1-15S163



(10) C1-15S180

MAGELLAN
MIDRCD.030;1
TEN Cx-MIDR'S
December 1991

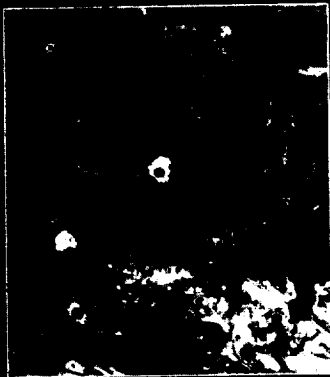

(1) C1-60N153



(2) C1-45N202



(3) C1-30S189



(4) C1-30N189



(5) C1-30N171



(6) C1-15N163



(7) C1-00N163



(8) C1-30S171



(9) C1-45S202



(10) C1-60S347

MAGELLAN
MIDRCD.031;1
TEN C1-MIDR'S
December 1991



(2) 25N223



(3) 20N227



(5) 10N234



(6) 10N217

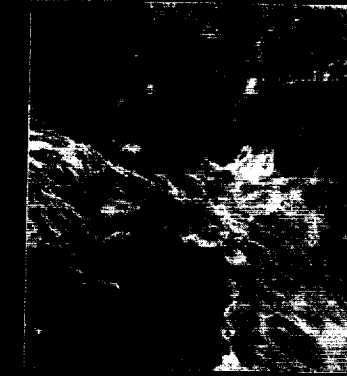

(7) 10N205

(4) 15N186



(8) 05N228



(9) 05S222

MAGELLAN
MIDRCD.032;1
TEN F-MIDR'S
December 1991

(10) 40S230



(1) C1-00N215



(2) C1-00N197



(3) C2-30N078

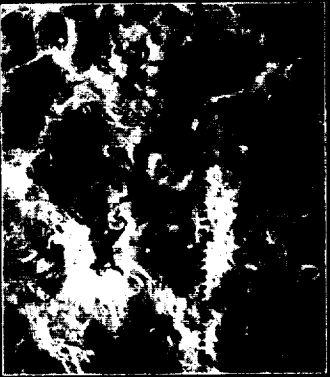

(4) C1-15S215



(5) C1-15S197

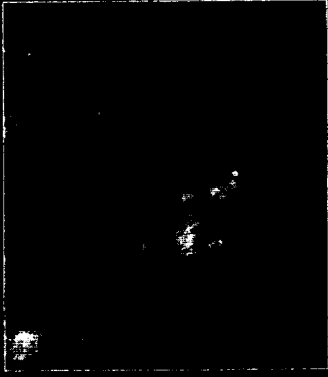

(6) C1-30S207

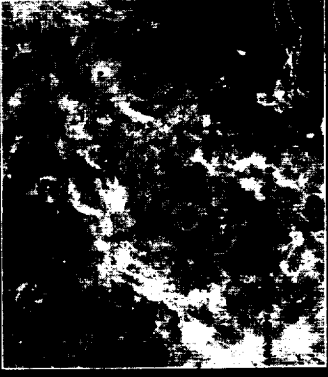

(7) C1-30N207



(8) C1-15N197



(9) C1-60S180

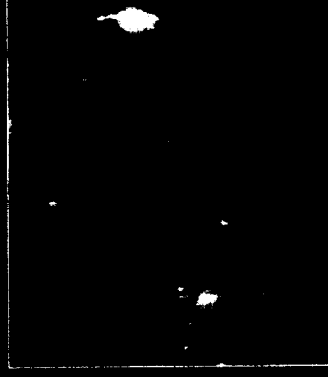

(10) C1-45S223

MAGELLAN
MIDRCD.0333;1
TEN Cx-MIDR'S
December 1991



(1) C1-15N215



(2) C2-30N129



(3) C2-30N026



(4) C2-00N131

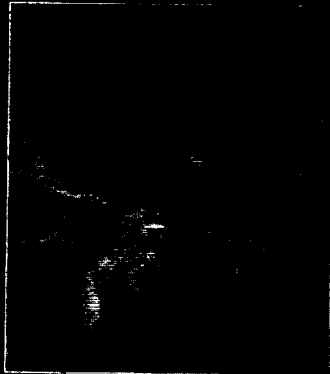

(5) C1-60S208

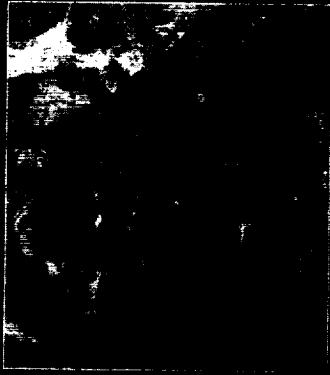

(6) C1-30S225

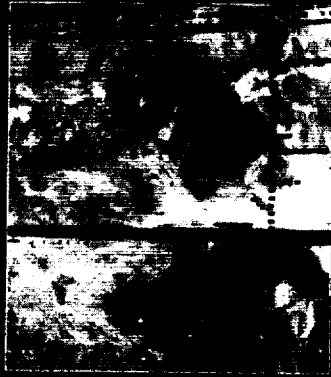

(7) C1-30N225



(8) C1-15S232



(9) C1-00N232

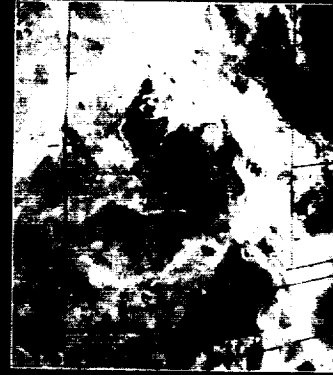

(10) C2-00N183

MAGELLAN
MIDRCD.034;1
TEN Cx-MIDR'S
December 1991



(2) 15N203



(3) 20S233



(4) 05S239

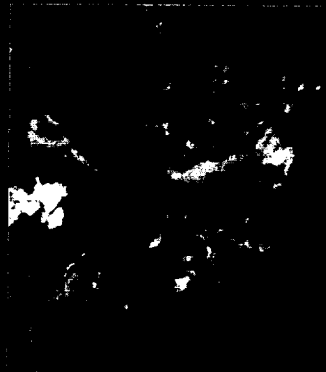

(6) 35N230



(7) 35S243



(8) 20N239



(5) 15N237



(10) 15S237

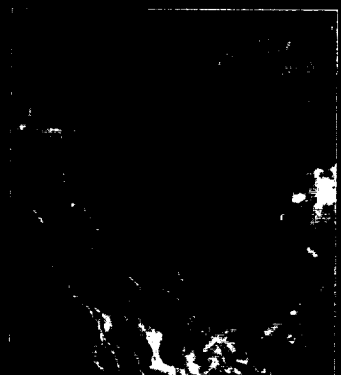

(9) 40N230

MAGELLAN
MIDRCD.035;1
TEN F-MIDR'S
December 1991



(4) 20N253



(3) 15N249



(8) 05S250



(7) 05N239

MAGELLAN
MIDRCD.036;1
TEN F-MIDR'S
December 1991

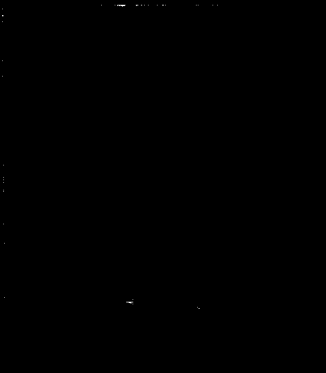

(2) 75N237



(6) 35N290



(10) 15N260



(1) 55N236



(5) 30N262



(9) 10S267



(1) C2-30S026



(2) C1-45N223



(3) C1-75N164

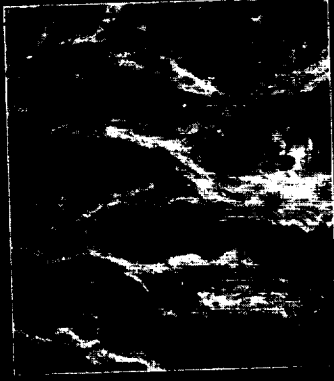

(5) C1-60N208



(6) C1-15N232



(7) C2-30S129



(8) C2-30S078



(9) C2-00N028



(10) C2-30S181

MAGELLAN
MIDRCD.037;1
TEN Cx-MIDR'S
December 1991



(2) 15S249

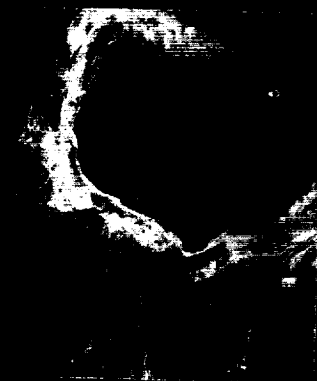

(1) 15S243



(6) 45N241



(5) 30N256



(9) 20S257



(4) 30N237



(7) 10N228



(8) 15S254

MAGELLAN
MIDRCD.038;1
TEN F-MIDR'S
December 1991

(10) 45S142

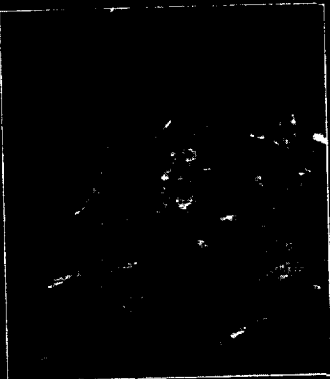

(1) 45N249

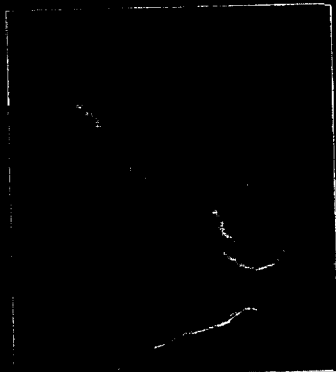

(2) 50N247



(3) 10S245



(4) 10S250



(5) 20S245



(6) 20S151

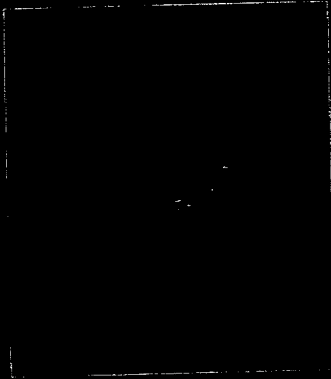

(7) 50S272

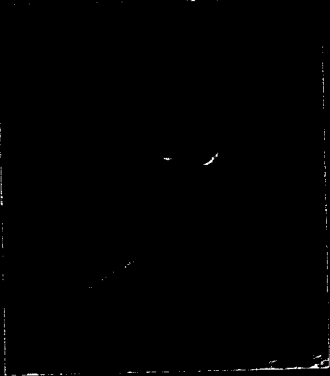

(8) 50S021



(9) 20S286



(10) 25S247

MAGELLAN
MIDRCD.039;1
TEN F-MIDR'S
December 1991



(1) 60N236



(2) 45S244



(3) 30S243



(4) 15S249



(5) 45N244



(6) 00N249

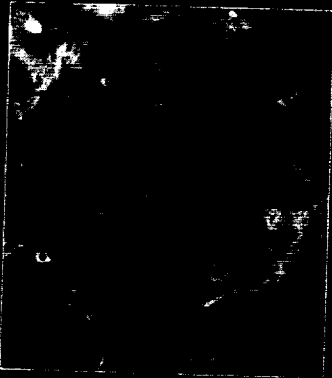

(7) 45S265



(8) 30S261



(9) 30N261



(10) 30N243

MAGELLAN
MIDRCD.040;1
TEN C1-MIDR'S
December 1991



(1) 15N266

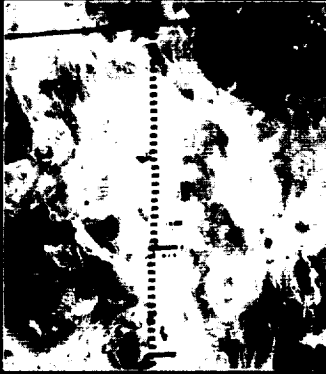

(2) 15N249

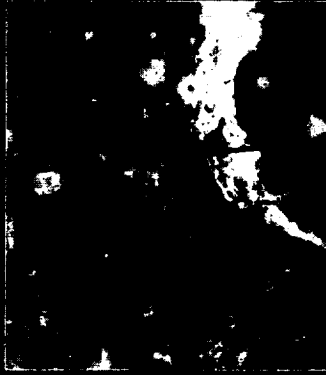

(3) 00N266



(4) 60N263



(5) 30S279

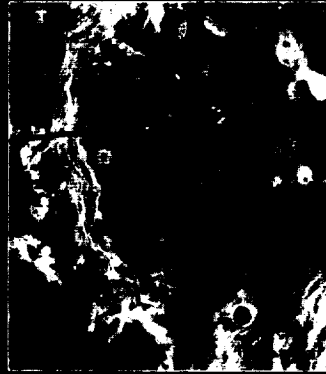

(6) 15S266

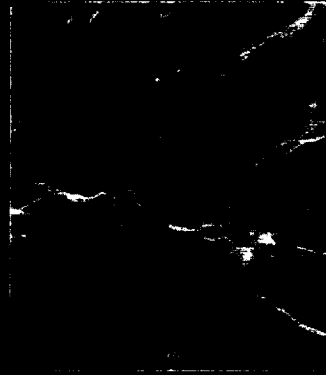

(7) 75N209

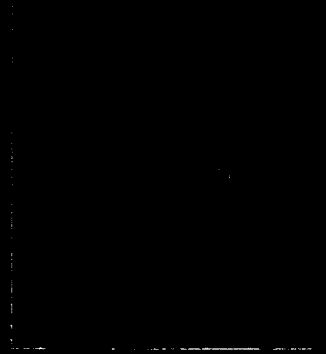

(8) 60S263

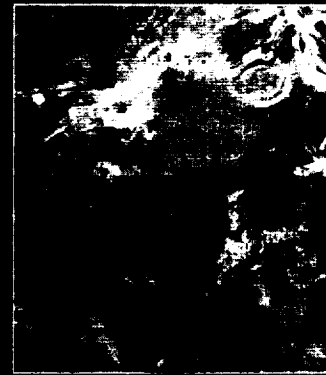

(9) 45N265

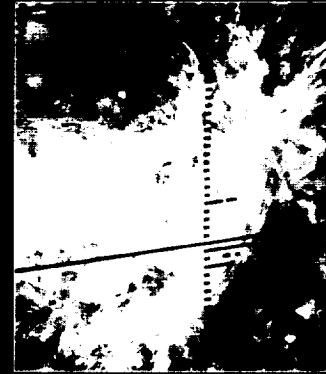

(10) 15S283

MAGELLAN
MIDRCD.041;1
TEN C1-MIDR'S
December 1991



(1) 25S259



(2) 30S268

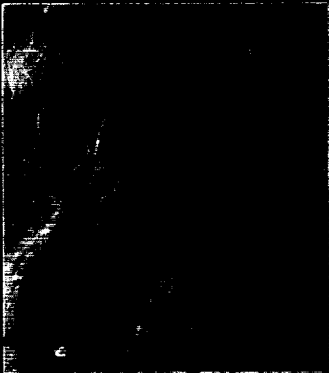

(3) 25S253

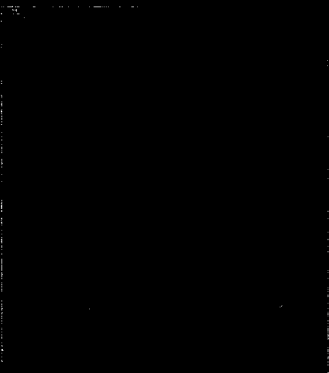

(4) 30S262

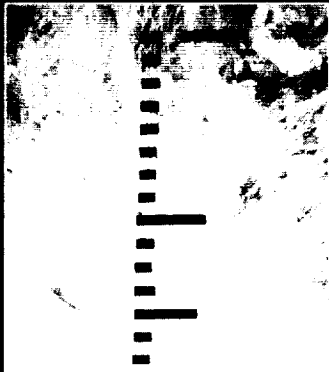

(5) 25N284



(6) 30N281



(7) 40N244

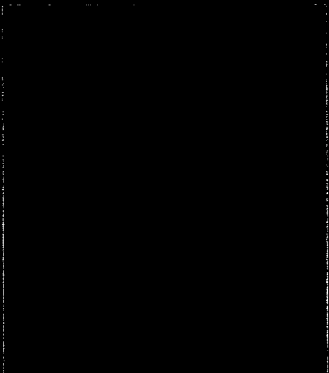

(8) 50N264



(9) 55N263

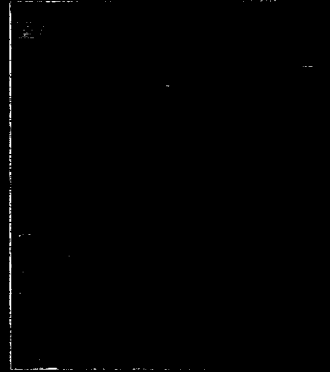

(10) 60N270

MAGELLAN
MIDRCD.042;1
TEN F-MIDR'S
December 1991



(1) C2-30N181

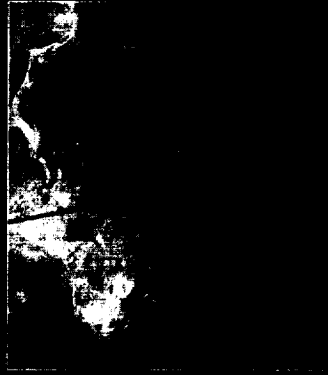

(2) C1-45S286



(3) C1-30N279



(4) C2-60N033



(5) C2-00N234



(6) C1-15N283



(7) C1-00N283



(8) C2-30N232

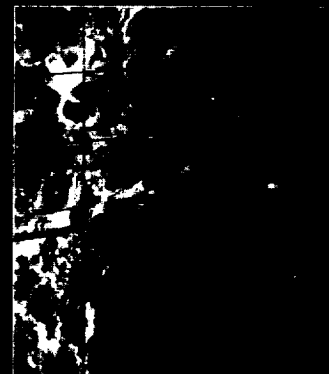

(9) C2-30S232

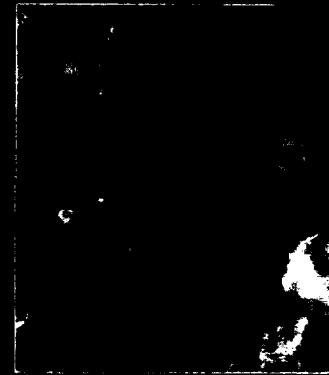

(10) C1-30S297

MAGELLAN
MIDRCD.043;1
TEN Cx-MIDR'S
December 1991

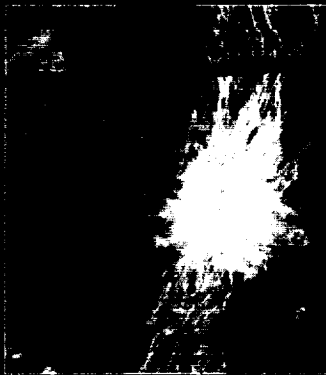

(1) 20N269

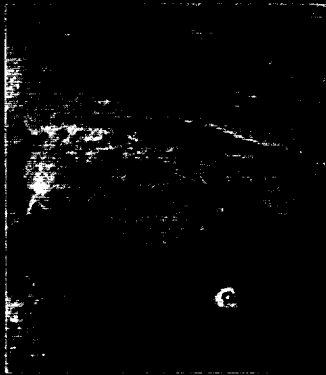

(2) 20N292



(3) 35N270



(4) 35N277



(5) 40N251

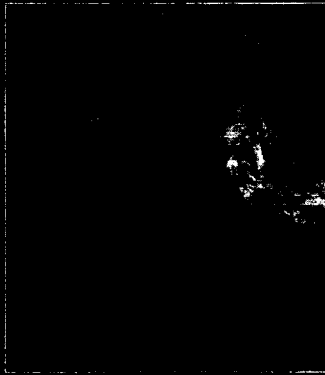

(6) 40N272



(7) 30N269



(8) 30N275



(9) 30N287

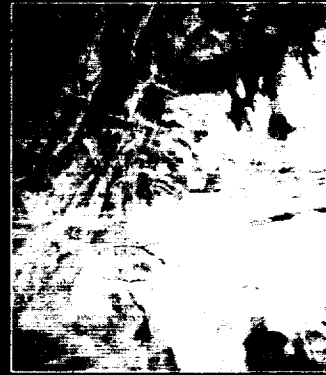

(10) 35N283

MAGELLAN
MIDRCD.044;1
TEN F-MIDR'S
December 1991



(1) 40N279



(2) 60N281



(3) 05N273



(4) 05N284



(5) 10N267

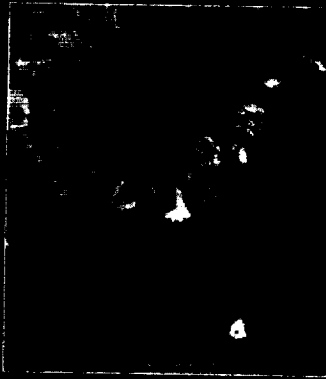

(6) 10N273

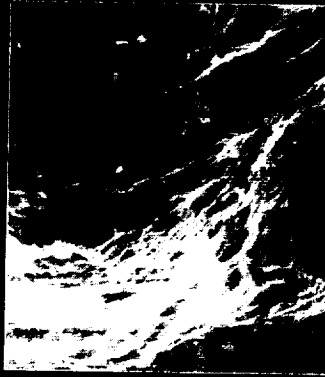

(7) 10N284

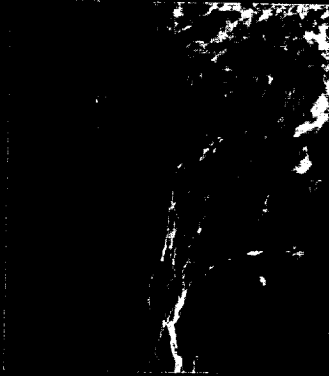

(8) 10S273

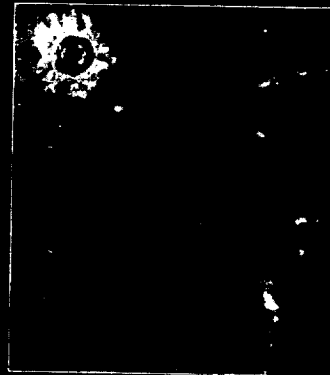

(9) 15N266



(10) 30S275

MAGELLAN
MIDRCD.045;1
TEN F-MIDR'S
December 1991

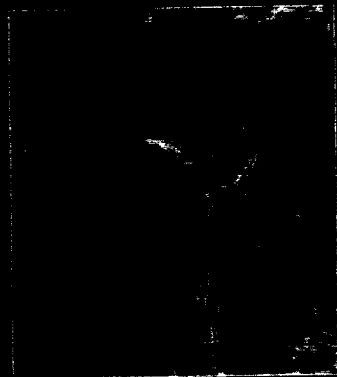

(1) 40N286



(2) 20N280



(3) 20N286



(4) 00N279



(5) 05N290

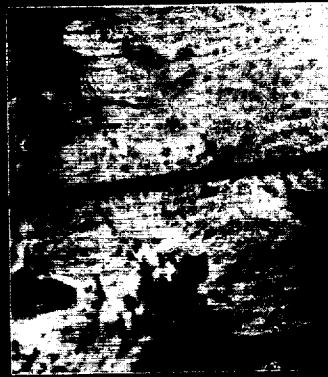

(6) 05S279



(7) 10S284



(8) 10S290



(9) 15S283



(10) 15S289

MAGELLAN
MIDRCD.046;1
TEN F-MIDR'S
December 1991

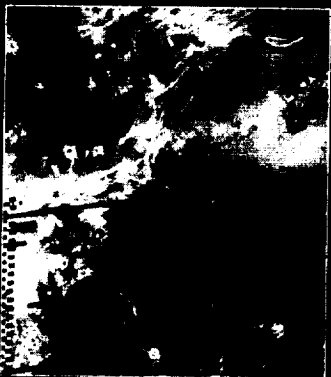

(1) C1-15S300

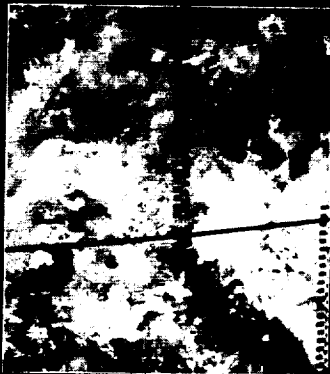

(2) C1-00N300

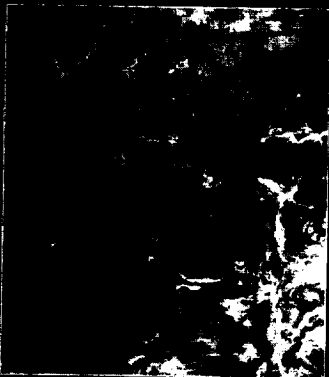

(3) C1-45N286



(4) C1-30N297

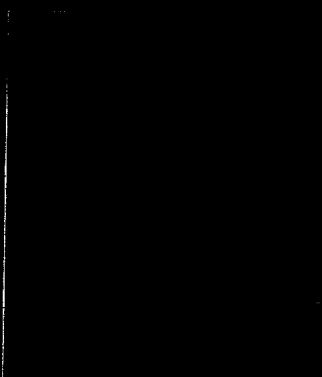

(5) C1-60S291



(6) C1-15N300

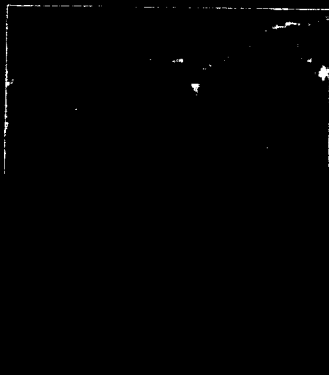

(7) C1-45N329



(8) C1-60N291



(9) C1-45N307



(10) C1-30S315

MAGELLAN
MIDRCD.047;1
TEN C1-MIDR'S
December 1991



(1) C1-15S317



(2) C1-15N317



(3) C1-00N317



(4) C1-30N315



(5) C1-75S248

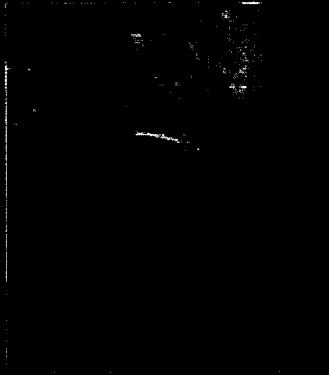

(6) C1-75S203



(7) C1-75N299



(8) C1-75S293



(9) C1-75N254



(10) C1-60N319

MAGELLAN
MIDRCD.048;1
TEN C1-MIDR'S
December 1991



(1) 40S279



(2) 35S290



(3) 10N279

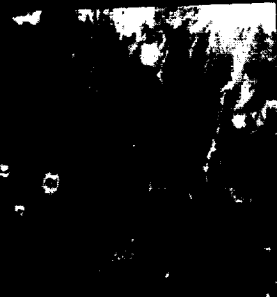

(4) 00N284

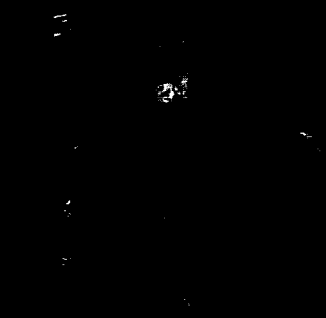

(5) 70N296



(7) 50N297



(8) 45S280



(10) 40S286



(9) 45N295

MAGELLAN
MIDRCD.049;1
TEN F-MIDR'S
April 1992

(1) 40S300

(2) 35N297

(3) 30N294

(4) 25S295

(5) 25N296

(6) 25N278

(7) 10S301

(8) 05S295

(9) 70N310

(10) 60N312

MAGELLAN
MIDRCD.050;1
TEN F-MIDR'S
April 1992

(1) C1-75S113;1

(2) C1-75S068;1

(3) C2-30N284;1

(4) C2-00N337;2

(5) C2-00N286;1

(6) C2-30S284;1

(7) C2-60N333;2

(8) C2-60N153;1

(9) C2-60N093;1

(10) C2-30N335;2

MAGELLAN
MIDRCD.051;1
TEN Cx-MIDR'S
April 1992

(1) 50N306;1



(2) 30N300;1



(6) 05N301;1

(3) 25S302;1

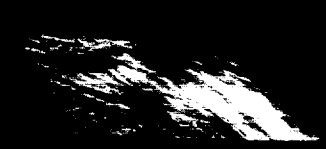

(7) 70N324;1

(4) 10S307;1

(8) 55N328;1

(5) 10N307;1

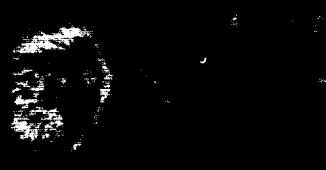

(9) 40N321;1

(10) 35N330;1

MAGELLAN
MIDRCD.052;1
TEN F-MIDR'S
April 1992

(1) 25N333;1



(2) 05N307;1



(3) 60N323;1



(4) 55N319;1

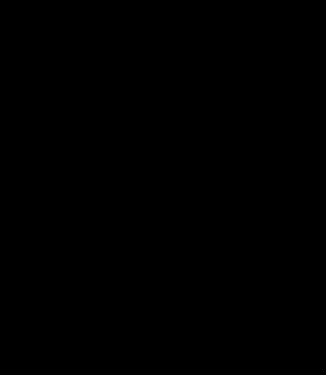

(5) 20N328;1

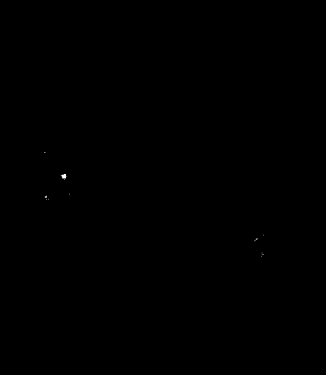

(6) 05N318;1

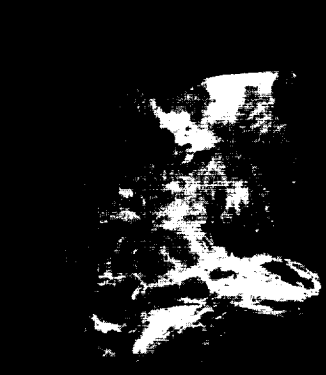

(7) 35S143;1

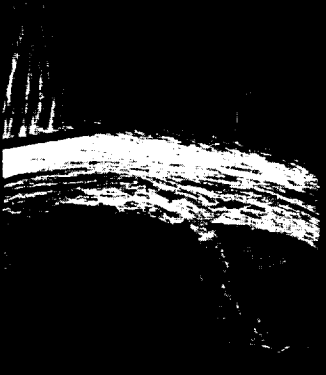

(8) 30S142;1



MAGELLAN
MIDRCD.053;1
TEN F-MIDR'S
April 1992

(9) 15N312;1



(10) 15S049;201



(1) C1-60N347;2

(2) C1-75S023;1

(3) C1-45N032;201

(4) C2-60N213;1

(5) C2-60S213;1

(6) C2-60S153;1

(7) C2-60S093;1

(8) C2-60S033;1

(9) C2-60S273;1

(10) C1-60S042;2

MAGELLAN
MIDRCD.054;1
TEN Cx-MIDR'S
April 1992

(1) 05S042;201

(2) 05S037;201

(3) 00N042;201

(4) 15N049;201

(5) 15N043;201

(6) 10N048;201

(7) 05N048;201

(8) 00N033;201

MAGELLAN
MIDRCD.055;1
TEN F-MIDR'S
May 1992

(9) 30N047;201

(10) 25N046;201



(1) 15N037:201



(2) 40N046:201



(3) 30N041:201

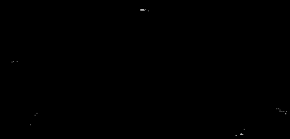

(4) 30N035:201



(5) 20N334:201



(6) 20N050:201



(7) 20N038:201



(8) 10S054:201



(10) 65N305:1

MAGELLAN
MIDRCD.056;1
TEN F-MIDR'S
April 1992

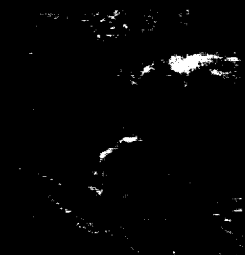

(9) 75N313:1



(4) C1-30N33S



(3) C1-30N045:201



(2) C1-15N335:2



(1) C1-15N043:201



(8) C1-60S74



(7) C1-50N043:201

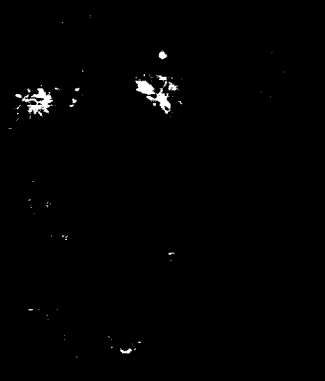

(6) C1-15S043:201



(5) C1-15S060:201

MAGELLAN
MIDRCD.057;1
TEN Cx - MIDR'S
May 1992



(10) C1-00N060:201



(9) C1-30S045:201

(1) 65N294:*

(2) 55N337:20*

(3) 55N333:70*

(4) 55N344:20*

(5) 60N048:201

(6) 65N318:1

(7) 65N344:20*

(9) 15S054:201

(10) 10N031:201

MAGELLAN
MIDRCD.058:1
TEN F-MIDR'S
May 1992

(1) 05S031:201

(2) 60N302:1

(3) 05S059:1

(4) 10N290:1

(5) 05S059:1

(6) 00N059:1

(7) 10N065:201

(8) 05S312:1

(9) 50S356:201

(10) 50S348:201

MAGELLAN
MIDRCD.059:1
TEN F-MIDR'S
May 1992

(1) C1-60S014:202

(2) C1-30N027:201

(3) C1-15S060:202

(4) C1-45S053:201

(5) C1-45N329:2

(6) C1-45S011:201

(7) C1-45S350:201

(8) C1-45N053:201

(9) C1-60N060:202

(10) C1-60S347:201

MAGELLAN
MIDRCD.060;1
TEN Cx-MIDR'S
May 1992

4

5

7

(4) C2-60N033:2

(3) C2-60N273:2

(2) C1-45S053:202

(1) C1-00N146:201



(8) C1-45N099:201

(7) C2-60N153:2

(6) C2-30N284:2

(5) C1-15S146:201

MAGELLAN
MIDRCD.061;1
TEN Cx-MIDR'S
May 1992

(10) C1-15N112:201

(9) C1-30N099:201

(1) 20N174:1

(2) 45S349:201

(3) 06N054:201

(4) 40N053:201

(5) 25N052:201

(6) 15N054:201

(7) 10N054:201

(8) 05N054:201

(9) 05S054:201

(10) 35N050:201

MAGELLAN
MIDRCD.062;1
TEN F-MIDR'S
May 1992



(4) 35S143:201



(3) 30S*42:201



(8) 50S154:1

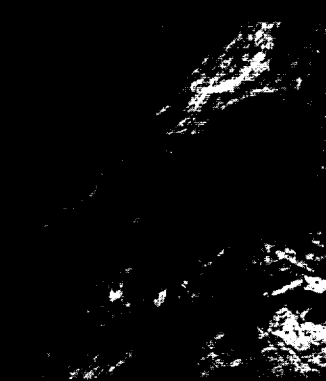

(2) 35N303:1

(7) 40S*38:201

MAGELLAN
MIDRCD.063;1
TEN F-MIDR'S
May 1992

(6) 55S356:201

(1) 30N054:201



(5) 35S137:201



(9) 15S117:201

(10) 15N112:201



(1) 15S163:201



(2) 25N174:1



(3) 05N194:201



(4) 00N194:201



(5) 00N189:201



(6) 00N115:201



(7) 15S112:201



(8) 20S162:201



(10) 05S115:201



(9) 30S098:201

MAGELLAN
MIDRCD.064;1
TEN F-MIDR'S
May 1992

(1) 15N174:1



(5) 20S174:1

(2) 15N169:1

(3) 10N172:1



(4) 15S169:1

(6) 10N166:1

(7) 30N161:1

(8) 30N167:1

MAGELLAN
MIDRCD.065;1
TEN F-MIDR'S
May 1992

(10) 35N163:1

(9) 30N174:1

(1) 55N171:1

(2) 55N180:1

(3) 49N159:1

(4) 45N187:1

(5) 45N188:1

(6) 50N163:1

(7) 50N180:1

(8) 50N175:1



MAGELLAN
MIDRCD.066;1
TEN F-MIDR'S
May 1992

(9) 15S077:1

(10) 15N220:1



(1) 15S220:1



(2) 15S226:1



(3) 20S227:1



(4) 35S270:1

(5) 40S201:1

(6) 40S272:1

(7) 40S208:1

(8) 45S234:1

MAGELLAN
MIDRCD.067;1
TEN F-MIDR'S
May 1992



(10) 05N115:201

(9) 65S114:1



(1) 05S205:201



(2) 10S115:201



(5) 25S131:201



(6) 30S142:202



(7) 35S143:202



(4) 40S145:201



(10) 15S174:1

MAGELLAN
MIDRCD.068;1
TEN F-MIDR'S
June 1992

(9) 45S218:201

(8) 65N102:201

(1) C1-30S063;201

(2) C1-75N338;2

(3) C1-75N029;2

(4) C1-55S;2

(5) C3-14N180;1

(6) C1-60N347;2

(7) C2-60S333;1

(8) C1-45S;1

(9) C1-30N117;1

(10) C1-75N074;201

MAGELLAN
MIDRCD.069;1
TEN CX-MIDR'S
June 1992

REPORT DOCUMENTATION PAGE

Form Approved
OMB No. 0704-0188

Public reporting burden for this collection of information is estimated to average 1 hour per response, including the time for reviewing instructions, searching existing data sources, gathering and maintaining the data needed, and completing and reviewing the collection of information. Send comments regarding this burden estimate or any other aspect of this collection of information, including suggestions for reducing this burden, to Washington Headquarters Services, Directorate for Information Operations and Reports, 1215 Jefferson Davis Highway, Suite 1204, Arlington, VA 22202-4302, and to the Office of Management and Budget, Paperwork Reduction Project (0704-0188), Washington, DC 20503.

1. AGENCY USE ONLY (Leave blank)		2. REPORT DATE March 1995	3. REPORT TYPE AND DATES COVERED Reference Publication	
4. TITLE AND SUBTITLE User Guide to the Magellan Synthetic Aperture Radar Images			5. FUNDING NUMBERS NASA7-1260	
6. AUTHOR(S) S. Wall, S. McConnell, C. Leff, R. Austin, K. Beratan, M. Rokey				
7. PERFORMING ORGANIZATION NAME(S) AND ADDRESS(ES) Jet Propulsion Laboratory California Institute of Technology 4800 Oak Grove Drive Pasadena, California 91109-8099			8. PERFORMING ORGANIZATION REPORT NUMBER _____	
9. SPONSORING/MONITORING AGENCY NAME(S) AND ADDRESS(ES) National Aeronautics and Space Administration Washington, DC 20546-0001			10. SPONSORING/MONITORING AGENCY REPORT NUMBER NASA RP-1356	
11. SUPPLEMENTARY NOTES				
12a. DISTRIBUTION / AVAILABILITY STATEMENT Unclassified -- Unlimited Subject Category 91 This publication is available from the NASA Center for AeroSpace Information, 800 Elkridge Landing Road, Linthicum Heights MD 21090-2934, (301) 621-0390			12b. DISTRIBUTION CODE	
13. ABSTRACT (Maximum 200 words) The Magellan radar-mapping mission collected a large amount of science and engineering data. Now available to the general scientific community, this data set can be overwhelming to someone who is unfamiliar with the mission. This user guide outlines the mission operations and data set so that someone working with the data can understand the mapping and data-processing techniques used in the mission. Radar-mapping parameters as well as data acquisition issues are discussed. In addition, this user guide provides information on how the data set is organized and where specific elements of the set can be located.				
14. SUBJECT TERMS Magellan; Venus; Radar; Geology; SAR			15. NUMBER OF PAGES 210	
			16. PRICE CODE	
17. SECURITY CLASSIFICATION OF REPORT Unclassified	18. SECURITY CLASSIFICATION OF THIS PAGE Unclassified	19. SECURITY CLASSIFICATION OF ABSTRACT Unclassified	20. LIMITATION OF ABSTRACT UL	