

1995/20871

405816
12p.

Load Measurement System With Load Cell Lock-Out Mechanism

Thang Le*
Monty Carroll*
Jonathan Liu*

Abstract

In the frame work of the project Shuttle Plume Impingement Flight Experiment (SPIFEX), a Load Measurement System was developed and fabricated to measure the impingement force of Shuttle Reaction Control System (RCS) jets. The Load Measurement System is a force sensing system that measures any combination of normal and shear forces up to 40 N (9 lbf) in the normal direction and 22 N (5 lbf) in the shear direction with an accuracy of ± 0.04 N (± 0.01 lbf). Since high resolution is required for the force measurement, the Load Measurement System is built with highly sensitive load cells. To protect these fragile load cells in the non-operational mode from being damaged due to flight loads such as launch and landing loads of the Shuttle vehicle, a motor driven device known as the Load Cell Lock-Out Mechanism was built. This Lock-Out Mechanism isolates the load cells from flight loads and re-engages the load cells for the force measurement experiment once in space. With this highly effective protection system, the SPIFEX load measurement experiment was successfully conducted on STS-64 in September 1994 with all load cells operating properly and reading impingement forces as expected.

Introduction

The Space Shuttle is maneuvered in space by RCS jets. These jets can produce significant plume impingement forces on surfaces that may be in the path of the jet plume. Among these surfaces are the solar arrays on the planned International Space Station Alpha or the Russian Mir Station. Due to the uncertainties of the analytical plume force predictions of the Orbiter RCS jets in the vacuum of high Earth orbit and the lack of direct empirical measurements, a project called SPIFEX was created.

The SPIFEX project consists of a 0.343-meter (13.5 in) diameter by 10-meter (32 ft) long boom with an avionics package and plume sensor array attached to one end. In operation, the Orbiter Remote Manipulator System (RMS), robot arm, grapples the other end of the boom providing power and communication and positions the plume sensor array over an RCS jet for a data point firing. The plume sensor data is recorded in the SPIFEX avionics for later downloading.

* Mechanical Systems Laboratory, Lockheed Engineering & Sciences Company, Houston, TX

A primary design factor for this project was minimizing cost. This factor led to no redundancy in the SPIFEX operational avionics or mechanisms. Three motor-driven mechanisms were used on SPIFEX: (1) a Two-Axis Drive to finely position the sensor array at the end of the boom, (2) a Lock-Down device to secure the Two-Axis Drive and sensor array for Space Shuttle launch and landing, and (3) a Load Cell Lock-Out Mechanism to isolate the Load Measurement System from Space Shuttle launch and landing loads. The Load Cell Lock-Out Mechanism is the topic of this paper.

Lock-Out Control System

The Lock-Out mechanism of the Load Measurement System is driven with a low-power DC gearmotor and with the end-to-end travel controlled by limit switch feedback to the SPIFEX avionics. Due to limited 28-VDC power allocation for SPIFEX, a low-power DC gearmotor with a high 4126:1 gear ratio and 13.5 N-m (120 in-lbf) peak torque permitted the use of a small 28-VDC relay drive with less than 1-Amp capacity. This combination provided a reasonable operation time of 15 seconds for the Load Cell Lock-Out to open or close. A DC motor was chosen to drive this mechanism because of the simplicity of the low-level control system and the simple open/close state of the mechanism. A high-level means of controlling the Lock-Out mechanism was provided from the SPIFEX avionics through a serial link to a Space Shuttle crew cabin laptop computer.

Load Measurement System

The purpose of the Load Measurement System is to measure the magnitude and to determine the direction of the plume force once the Load Measurement System is placed in the plume field. The Load Measurement System consists of two major components: a flat panel to catch the jet plume and an array of load cells to sense the plume force. The panel is called the Load Plate, and the load cell array is known as the Load Ring (Figure 1).

The Load Plate is a rectangular surface that provides a flat area to capture the impingement of the RCS jet in the plume field. The Load Plate has a honeycomb structure of aluminum. Woven graphite sheets are used for the plate close-outs for all sides. This method of construction provides the necessary stiffness for the Load Plate while minimizing its mass. The Load Plate minimal mass is required so that the Load Measurement System can be responsive to the brief plume forces. A natural frequency of 100 Hz or higher is required for the plate. The light-weight plate also prevents the load cells from being subjected to strenuous forces during the non-experiment phases.

The Load Ring has six uniaxial strain gage load cells arranged in a circular pattern. The load cells are installed with a universal joint at each end to form six struts between the Load Plate and the base structure of the Load Measurement System. This arrangement permits the Load Plate to have 6 degrees of freedom (DOF) movement

with respect to the base structure when lengths of the strut vary. In other words, once a force is applied on the Load Plate, the infinitesimal movement of the Load Plate can be detected by the reaction forces in the six struts. The reaction forces are the actual compression or tension forces sensed by the individual load cells within the struts.

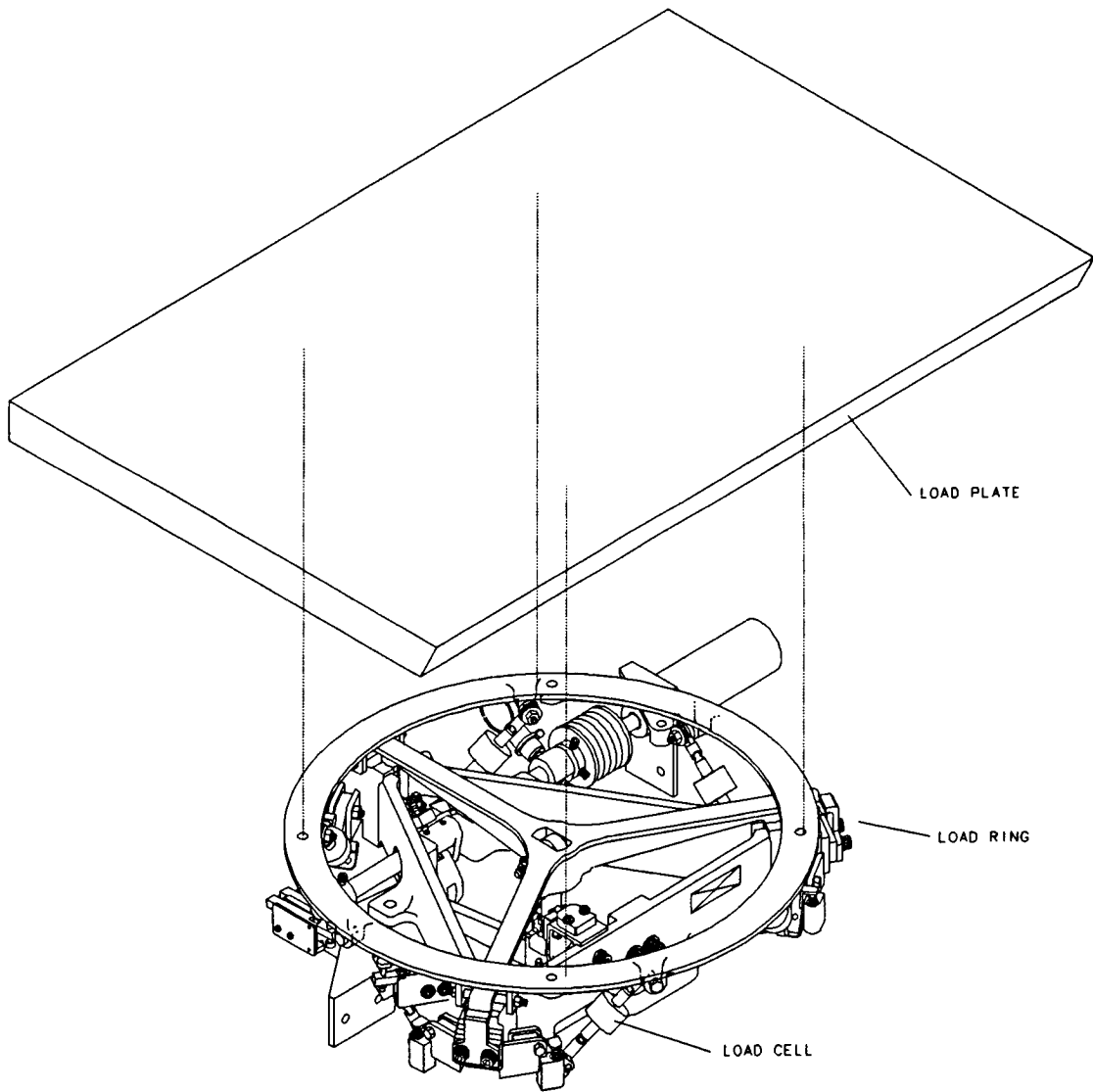

Figure 1. Load Measurement System

The universal joints at the load cell ends prevent a bending moment from being transferred and allow nothing but strictly axial load through the load cells. The six struts with universal joints form a statically determinate structure from which the total force exerted on the Load Plate can be derived from the individual axial forces in the load cells. Thus, the input force can be computed from the force readings in the six

load cells to yield three force components and three moment components of the applied force.

The Load Ring and the Load Plate are held together by several structural members as illustrated in Figure 1. A majority of these members are made from aluminum because of its light weight. A few members are made of stainless steel where large deflection is not desirable.

Force Calculation

To calculate the external force, **FX**, **FY**, **FZ**, and moments, **MX**, **MY**, **MZ**, acting on the Load Plate, the six load cell force readings are decomposed into component **x-y-z** forces using the **x-y** connection position of the universal joints and orientation of the load cells. The component forces are then summed into composite **X-Y-Z** forces acting on the Load Plate. The composite **X-Y-Z** moments acting on the Load Plate are calculated by summing the component forces times the distance from the axis of interest. The axis of interest is defined by the offsets, **Xoff**, **Yoff**, **Zoff**, from the Load Measurement System origin. The origin (0,0,0) is defined at the **x-y** center of the circle of load cell struts and the **x-y** plane that passes through the load cell upper universal joint pivot points. The resulting matrix equation is as follows:

$$\begin{bmatrix} \text{FX} \\ \text{FY} \\ \text{FZ} \\ \text{MX} \\ \text{MY} \\ \text{MZ} \end{bmatrix} = \mathbf{T} \cdot \mathbf{F} - \begin{bmatrix} \text{FXoff} \\ \text{FYoff} \\ \text{FZoff} \\ \text{MXoff} \\ \text{MYoff} \\ \text{MZoff} \end{bmatrix}$$

where **F** is the vector of six force readings of the load cells, and **T** is the constant matrix describing the Load Ring geometry. The matrix equation also shows where a static force or moment offset can be removed from the result. Refer to the notes at the end of this paper for the complete matrix derivation.

Load Cell Lock-Out System

The purpose of the Load Cell Lock-Out System is to provide an alternate load path for the system so that the force passing through the load cells from the Load Plate to the base structure can be minimized during the harsh vibration phase of launch and landing of the Shuttle vehicle. During this vibration period all load cells are isolated, or locked, for protection. The load cells then can be returned to the unlocked configuration for operation during the load measurement experiment.

The Load Cell Lock-Out system is an over-center mechanism driven by a DC gear motor (Figure 2). The upper end of each load cell is connected to the Load Plate via a universal joint. The lower end of a load cell is connected to a linkage, also, through a universal joint. In the operational, unlocked position, the linkage is spring loaded against a hard stop (Figure 3). The Load Measurement System is then subjected to plume forces for force measurement in this configuration, and all six load cells act as the primary load path from the Load Plate to the base structure.

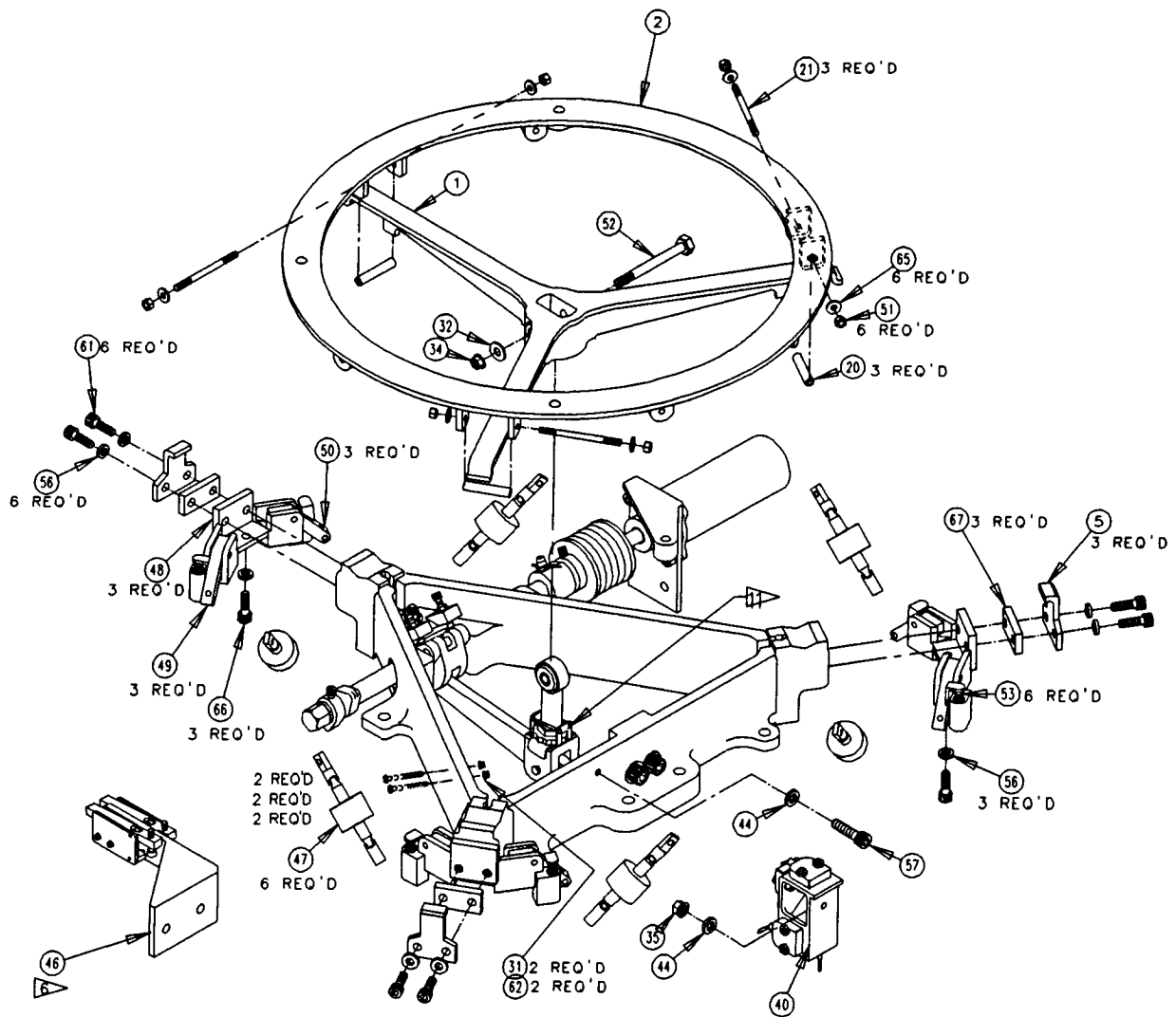

Figure 2. Load Cell Lock-Out Mechanism

Once in the non-operational locked mode, a set of three hooks reach up and clamp down the Load Plate to rigidize the plate to the base structure. In this configuration, the linkage at the load cell lower end compresses the spring to separate the load cell lower

end from the hard stop to minimize the load transferred through the load cells. The clamping hooks act as the primary connection for load transferred from the Load Plate to the base structure. When the Load Measurement System is returned back to the operation mode, these clamping hooks are completely separated from the Load Plate so that only the load cells are subjected to the energy transfer.

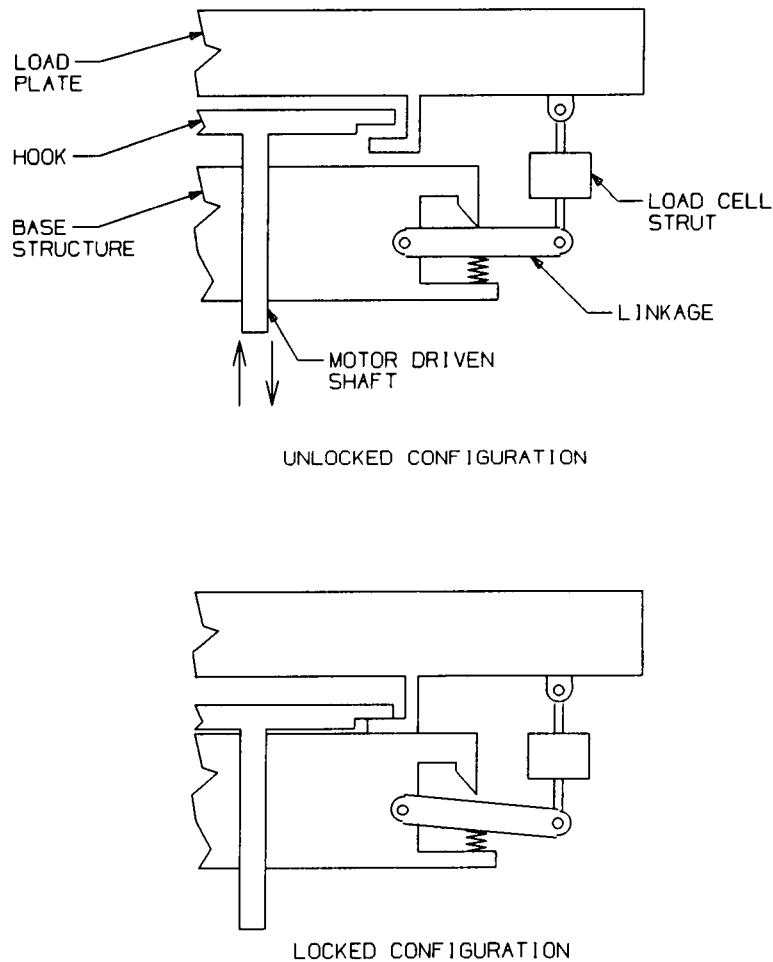

Figure 3. Load Cell Lock-Out System Schematic

Furthermore, the linkage springs are preloaded in such a way that when the load cells are compressed in the locked position, the spring compression force is equal to the load cell full-scale capacity. Therefore, the load cells measuring capability is maximized. The linkage spring system also provides a means of overload protection during the operation mode should the magnitude of the applied force exceed the spring preload. In this case, the spring is compressed, and the force magnitude passing through the load cell is confined.

All linkages and pivot pins in the drive system are made from stainless steel for higher strength. The DC gear motor has a high-ratio gearhead and is deactivated by limit switches once the mechanism is in a complete locked or unlocked state. Additional features include adjusting screws and a pip pin. Six spring adjusting screws allow the fine tuning of the spring preload at the linkages. Another six position adjusting screws provide the system with a means of alignment for the orientation of the Load Plate with respect to the base structure. The pip pin is used for quick disengagement of the motor from the shaft. This disconnection permits the mechanism to be manually actuated as desired using a standard 7/16 hex wrench.

System Performance on STS-64

The SPIFEX mission on STS-64 collected data for as many as 105 test points. Force measurement data were recorded in terms of voltage readings by the load cells and by their interpreted axial force in the individual load cells. All load cells were locked prior to payload installation and were not unlocked for the experiment, in orbit, until about eight weeks later. During the experiment, all six load cells were operational and reading forces properly. With the force magnitudes in all six load cells recorded, the composite force applied on the Load Plate can be calculated. A typical composite force of normal direction to the Load Plate is illustrated in Figure 4. The rectangular Load Plate has a dimension of 0.33 m by 0.51 m (13 in. by 20 in.). The force exerted per unit area can be easily obtained.

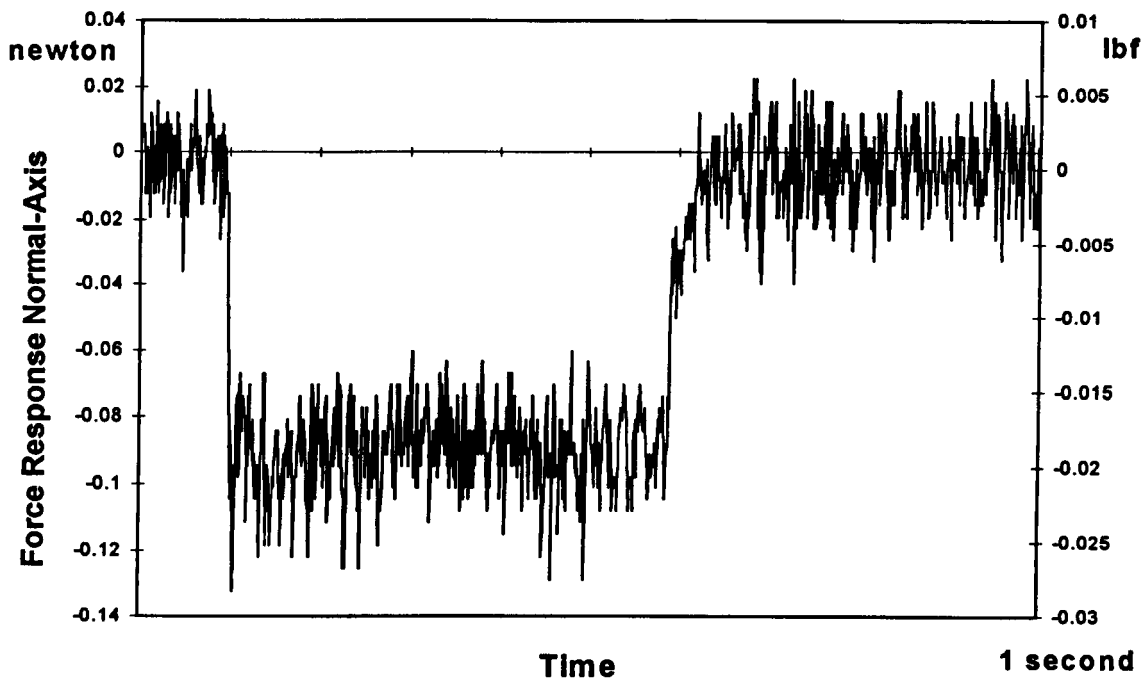

Figure 4. Typical Normal Composite Force Response

Conclusion

The design work of the Load Measurement System was begun in June 1992. The system design was then presented at the SPIFEX Preliminary Design Review in October 1992 and at the SPIFEX Critical Design Review in July 1993. Fabrication of two complete units (one qualification unit and one flight unit) was completed in March 1994. Photographs of the unit prior to installation on the SPIFEX boom are shown in Figure 5. The system was flown on the OV-103 (*Discovery*), STS-64 mission, in September 1994.

The Load Measurement System has successfully collected plume force data. All load cells endured the harsh environment of launch and landing conditions and were completely functional during flight and postflight. Preflight and postflight calibrations of the system indicate no degradation of the force measurement capability and its sensitivity. This fact illustrates that the load cells were efficiently protected by the Load Cell Lock-Out System and its Motor Controller.

The design of the 6-DOF force measurement platform utilizes only uniaxial load cells to measure all three force and three moment components as opposed to using complex multiaxis load cells. This concept can be adopted for various force torque measurement applications. The Lock-Out Mechanism idea can also be used to protect fragile instruments under severe conditions to ensure their functionality during the operating mode.

Acknowledgments

The authors wish to thank the SPIFEX team, which provided valuable support throughout the project.

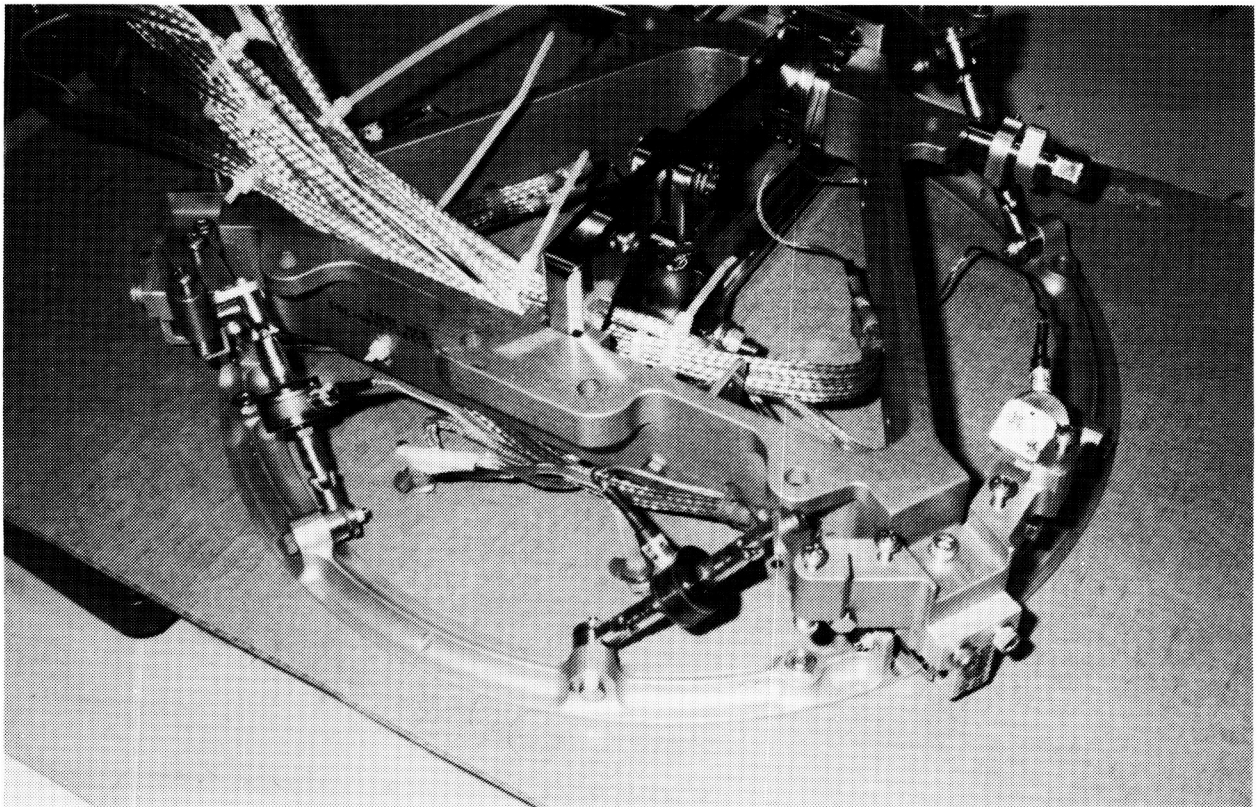
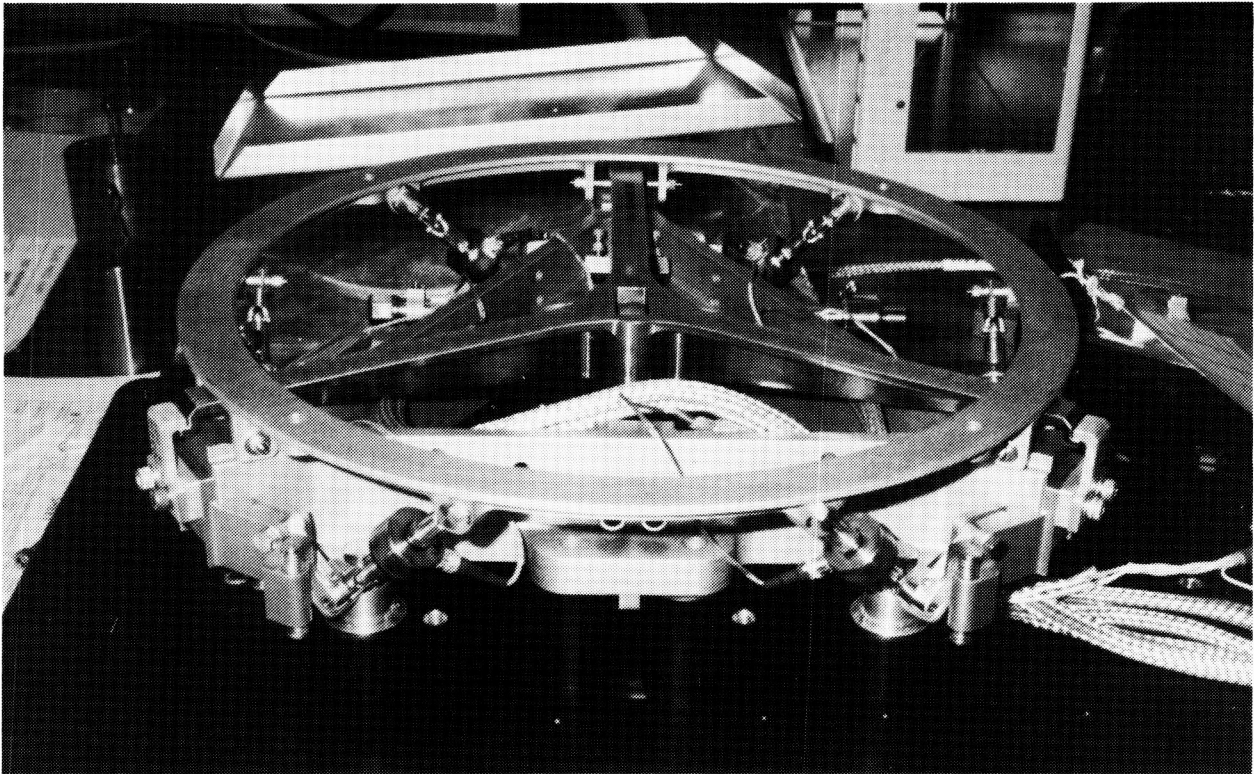

Figure 5. The Load Measurement System with Lock-Out Mechanism

Notes - Load Plate Force Derivation

The general equations to calculate the forces acting on the Load Plate can be determined given the following Load Ring geometric properties:

L	= length of load cell strut between pivot points.
β	= angle of load cell relative to x-y plane.
α	= angle of load cell relative to x-axis.
r	= radius of load cell upper pivot points.
PU, PL	= upper and lower universal joint x-y pivot points.
i	= number of struts (6).

First, the angle of each load cell strut projected into the x-y plane is calculated relative to the x-axis.

$$\alpha_i := \text{angle}(PUx_i - PLx_i, PUy_i - PLy_i) \quad (1)$$

Once the x-axis orientation of each strut is known including the Load Ring geometric properties, the force, **F**, from each load cell is broken down into component **x-y-z** forces and then summed to get the composite forces. The moments acting about the axis of interest on the Load Plate are calculated and then summed to get the composite moments. Any initial force or moment offset is also removed from the result. The equations are given below.

$$\begin{aligned} Fx_i &= F_i \cdot \cos(\beta) \cdot \cos(\alpha_i) & Mx_i &= Fz_i \cdot (PUy_i - Yoff) + Fy_i \cdot Zoff \\ Fy_i &= F_i \cdot \cos(\beta) \cdot \sin(\alpha_i) & My_i &= (-Fz_i) \cdot (PUx_i - Xoff) - Fx_i \cdot Zoff \\ Fz_i &= F_i \cdot \sin(\beta) & Mz_i &= Fy_i \cdot (PUx_i - Xoff) - Fx_i \cdot (PUy_i - Yoff) \end{aligned} \quad (2)$$

$$\begin{aligned} FX &= \sum_{(i=1..6)} Fx_i - FXoff & MX &= \sum_{(i=1..6)} Mx_i - MXoff \\ FY &= \sum_{(i=1..6)} Fy_i - FYoff & MY &= \sum_{(i=1..6)} My_i - MYoff \\ FZ &= \sum_{(i=1..6)} Fz_i - FZoff & MZ &= \sum_{(i=1..6)} Mz_i - MZoff \end{aligned} \quad (3)$$

To determine the forces, F , on each of the load cells, the equations (2) and (3) are combined to form six simultaneous equations (4).

$$\begin{aligned}
 FX &= \sum_{(i=1..6)} F_i \cdot \cos(\beta) \cdot \cos(\alpha_i) - FX_{\text{off}} \\
 FY &= \sum_{(i=1..6)} F_i \cdot \cos(\beta) \cdot \sin(\alpha_i) - FY_{\text{off}} \\
 FZ &= \sum_{(i=1..6)} F_i \cdot \sin(\beta) - FZ_{\text{off}} \\
 MX &= \sum_{(i=1..6)} \left[F_i \cdot \sin(\beta) \cdot (PU_{y_i} - Y_{\text{off}}) + F_i \cdot \cos(\beta) \cdot \sin(\alpha_i) \cdot Z_{\text{off}} \right] - MX_{\text{off}} \\
 MY &= \sum_{(i=1..6)} \left[-F_i \cdot \sin(\beta) \cdot (PU_{x_i} - X_{\text{off}}) - F_i \cdot \cos(\beta) \cdot \cos(\alpha_i) \cdot Z_{\text{off}} \right] - MY_{\text{off}} \\
 MZ &= \sum_{(i=1..6)} \left[F_i \cdot \cos(\beta) \cdot \sin(\alpha_i) \cdot (PU_{x_i} - X_{\text{off}}) \dots \right. \\
 &\quad \left. + (-F)_i \cdot \cos(\beta) \cdot \cos(\alpha_i) \cdot (PU_{y_i} - Y_{\text{off}}) \right] - MZ_{\text{off}}
 \end{aligned} \tag{4}$$

The six equations in (4) are then placed in the following matrix format.

$$\begin{bmatrix} FX \\ FY \\ FZ \\ MX \\ MY \\ MZ \end{bmatrix} = T \cdot F - \begin{bmatrix} FX_{\text{off}} \\ FY_{\text{off}} \\ FZ_{\text{off}} \\ MX_{\text{off}} \\ MY_{\text{off}} \\ MZ_{\text{off}} \end{bmatrix} \tag{5}$$

Where the constant matrix \mathbf{T} in (5) is defined as

$$\begin{aligned}T_{1,i} &:= \cos(\beta) \cdot \cos(\alpha_i) \\T_{2,i} &:= \cos(\beta) \cdot \sin(\alpha_i) \\T_{3,i} &:= \sin(\beta) \\T_{4,i} &:= [\sin(\beta) \cdot (PUy_i - Yoff) + \cos(\beta) \cdot \sin(\alpha_i) \cdot Zoff] \\T_{5,i} &:= [-\sin(\beta) \cdot (PUx_i - Xoff) - \cos(\beta) \cdot \cos(\alpha_i) \cdot Zoff] \\T_{6,i} &:= [\cos(\beta) \cdot \sin(\alpha_i) \cdot (PUx_i - Xoff) - \cos(\beta) \cdot \cos(\alpha_i) \cdot (PUy_i - Yoff)]\end{aligned}\tag{6}$$