

N95-27989

VARIABLE SPEED GENERATOR APPLICATION ON THE MOD-5A  
7.3 MW WIND TURBINE GENERATOR

Robert S. Barton

General Electric Company, AEPD  
King of Prussia, Pa., 19406

DOE/NASA Horizontal-Axis Wind Turbine Technology Workshop, May 8-10, 1984, Cleveland, Ohio.

ABSTRACT

This paper describes the application of a Scherbiustat type variable speed subsystem in the MOD-5A Wind Turbine Generator. As designed by General Electric Company, Advanced Energy Programs Department, under contract DEN 3-153 with NASA Lewis Research Center and DOE, the MOD-5A utilizes the subsystem for both starting assistance in a motoring mode and generation in a controlled airgap torque mode. Reactive power control is also provided. The Scherbiustat type arrangement of a wound rotor machine with a cycloconverter in the rotor circuit was selected after an evaluation of variable speed technologies that followed a system evaluation of drivetrain cost and risk. The paper describes the evaluation factors considered, the results of the evaluations and summarizes operating strategy and performance simulations.

INTRODUCTION

The MOD-5A Wind Turbine Generator design program was started in July, 1980. After conceptual design and preliminary design phases were completed, the MOD-5A configuration was rated at 7300 KW and featured a synchronous generator and two-speed rotor operation through a shiftable gearbox. The gearbox also provided drivetrain dynamics control through torsion bar springs and dampers as described in Reference 1.

When final design and procurement started, it was found desirable to minimize the gearbox complexity and to provide a drivetrain back-torque during controlled shutdowns. The latter reduced cyclic loads that were design drivers for the aerodynamic partial span control. A variable speed generator subsystem was selected to meet these needs. The partial span control was subsequently replaced with an aileron control, and the variable speed generator subsystem provides startup assistance by motoring the rotor.

The MOD-5A design was performed under Contract DEN 3-153 for NASA Lewis Research Center and DOE by General Electric Company, Advanced Energy Programs Department.

MOD-5A SYSTEM

The MOD-5A model 304.2 system is shown in Figure 1. A static Scherbius or Scherbiustat type variable speed generator subsystem is used. This arrangement can motor the blades up to above 3 rpm and is capable of generating with rotor speeds from 12 to 17.5 rpm.

System requirements for the subsystem were:

1. Reduce gearbox complexity by providing drivetrain stiffness and damping control.
2. Reduce aerodynamic shutdown loads by providing drivetrain back torque down to 12 rpm.
3. Motor high inertia rotor to above 3 rpm to assist aileron rotor starting.
4. Improve energy capture by changing speed ranges while delivering power.
5. Operate over a range from 67% to 100% of maximum speed while generating (system frequencies prevent using a larger range).
6. Regulate airgap torque in response to a system reference. This is used to control system speed, control drivetrain dynamics, and limit maximum torque.
7. Regulate reactive power or voltage

The major components of the variable speed subsystem are located as shown in Figure 2.

CONFIGURATION

The four methods shown in Figure 3 were initially considered to provide variable speed capability. The mechanical Scherbius system would drive the ring gear of a planetary gear stage using an induction motor variable speed drive. The static Kramer system is limited to speeds above the synchronous speed of the machinery and, therefore, requires a higher rated overspeed and higher converter power for the speed range. A study of A-C drive technology (Reference 2), was reviewed and applications of variable speed to wind generation (References 3 through 6) were considered. Either a Scherbiustat or a Load Commutated Inverter (LCI) type drive system, operated as a generator would meet the system requirements and were studied further.

EVALUATION

A variable speed subsystem specification was prepared and quotations were obtained to assist in the evaluation. Specification functional topics are shown in Table 1. Major generator requirements are shown in Table 2. Quotations were received from two GE components and from Siemens-Allis.

Both LCI and Scherbiustat arrangements met the system requirements. The GE LCI has an advanced digital control design and a market position in drive applications. A lower recurring cost is offered by the Scherbiustat due to a lower converter rating. Utility interface compatibility and preferences are still open issues. A Scherbiustat variable speed subsystem was selected for the MOD-5A model 304.2 design on subsystem cost.

#### LCI CONFIGURATION

The main LCI configuration used in the evaluation was based on a GE Drive Systems Department 10,000 hp drive. Arranged as shown in Figure 4, the major components of the LCI are a 4160 V salient pole machine and a dual channel rectifier-inverter. The arrangement, described in Reference 7, is capable of continuous speed variation from zero to maximum speed. A digital control is used and fault recovery logic is implemented in the converter firing control. Reactive power or voltage control is not used for drive applications and would require a small change to the control.

Each channel of the converter is a half-rated 6 pulse bidirectional rectifier-inverter. Dual machine windings and transformer connections provide the equivalent of 12 pulse performance with respect to harmonics. A wound stator type brushless exciter on the machine provides zero speed field control. The individual cells of each channel are shown in Figure 5 with some of the system features. Each bridge leg has 6 cells, but can operate with 5 cells, so a single shorted cell does not force an outage. A costly 4 KV fuse is avoided by providing sufficient leg impedance to limit fault currents to reasonable levels until the main circuit breaker operates to clear the fault.

Primary protection and switching are provided by a utility voltage level circuit breaker. Harmonic filters and power factor correction capacitance are also provided at the utility voltage. The capacitance compensates for the inverter stage reactive power demand. Control of the inverter firing angle permits operation over the full power range with a utility power factor near unity. In the generating mode, the converter operates as a line commutated device. When motoring for startup, the machine "load" provides commutation with field control.

#### SCHERBIUSTAT CONFIGURATION

The Scherbiustat circuit is shown in Figure 6. This also has a simplified one-line diagram of the Hawaiian Electric Company (HECO) distribution system at Kahuku on the island of Oahu where a MOD-5A installation was planned. The arrangement is similar to the GE supplied 15,000 hp drive used on the Princeton, N. J. pulse power generator described in Reference 8. A Canadian General Electric unit was used for evaluation. A wound rotor or doubly-fed machine is connected to the grid directly at the stator and through a cycloconverter at the rotor. Cycloconverters have been used for full power speed control of machines as described in Reference 9 and the Scherbiustat arrangement is an active research topic for wind turbine and other applications.

Three 4 KV circuit breakers are used to protect the cycloconverter (52-1), connect the stator to the grid (52-2), and short circuit the stator for starting (52-3). The cycloconverter rating of 1500 KVA provides for generator operation from 12 rpm to 17.5 rpm at the wind rotor and for motoring to 3+ rpm.

The cycloconverter is arranged as three standard 6-pulse reversing DC drives, as shown in Figure 7. With a machine turns ratio of near 1:1, the input voltage to the cycloconverter at maximum slip permits use of a single series cell with fuse protection. A completely redundant cell arrangement was used to provide ride-through capability in the event of a cell failure, similar to the LCI capability. A multiple winding, balanced impedance transformer is used to isolate the cycloconverter bridges and both sum and step-up their output to 4160 V. Power factor correction capacitance and harmonic filters are connected at the 4160 V bus. A hybrid control, the GE Directomatic II, was planned for the initial unit. The operating range of the Scherbiustat arrangement is shown in Figure 8. Machine stator power is available up to the 6500 KVA stator thermal rating. Through the cycloconverter, power is supplied to the rotor below synchronous speed and extracted from the rotor above synchronous speed. The planned speed-torque control characteristic is also shown in high and low ranges. This control characteristic is determined by the wind turbine generator controller and would be the same for either a Scherbiustat or an LCI variable speed subsystem.

#### COMPARISON

Performance comparisons of the two subsystem arrangements were made and relative weighing factors were applied to the system criteria as shown in Table 3. Emphasis was placed on prototype unit performance, as well as volume production characteristics. The cost and performance comparisons were made at the full subsystem level, including utility voltage step-up level, housing of converter equipment, cable sizes, switchgear, and annual maintenance. For example, the time and cost to periodically clean the brush rigging compartment and replace brushes was included for the Scherbiustat arrangement. The evaluation details are not described in this paper.

An electrical-slanted comparison is shown in Table 4. This ranks the two configurations very close together.

Harmonic content is an issue for utility acceptance of static power converters, as used in both arrangements. IEEE Guide 519 (Reference 10) is generally used to establish harmonic control and reactive compensation levels, subject to utility requirements. These guidelines, along with the planned HECO/GE conditions are shown in Table 5.

As the LCI produces 12 pulse harmonic currents and is effectively DC fed, the filtering design necessary to provide a smooth output is not complex, but the filters have to contend with full power harmonic amplitudes. The Scherbiustat, with a 6 pulse cycloconverter, produces higher amplitude, more complex harmonics that vary with slip frequency, but only with 20% of the system output. An unfiltered, simplified analysis is shown in Figure 9, based on

Reference 11. The total output waveform distortion is about 5% prior to filtering. A complete site specific harmonic analysis was planned for MOD-5A.

Summarizing again, the overall evaluation determined that both subsystem arrangements met the requirements. While the LCI had more flexibility and was rated slightly higher than the Scherbiustat, it was also more costly for initial and volume production wind turbines. A Scherbiustat configuration was, therefore, selected for the MOD-5A. Utility preference was being evaluated and is still considered an open issue.

#### PERFORMANCE

A simulation model of the MOD-5A is shown in Figure 10. The important drivetrain and tower bending modes are included. Both simple and complex converter and generator models were developed. The simple model does not include the electrical dynamics, while the complex model does, and permits analysis of the quadrature real and reactive power regulator circuits that drive the cycloconverter firing control.

Gust performance of the simplified model is illustrated in Figures 11 and 12. The basic gust is a 12 second period, 9 mph, sinusoidal shape departing from an average 45 mph wind. A turbulent harmonic wind is added in Figure 12, in accordance with the NASA interim turbulence definition. Trade winds are not expected to be as turbulent as the NASA definition.

The generator torque level is clamped at just above rating by the control logic as shown in Figure 11, set b. Total output increases slightly above the clasp plateau as the generator speed continues to increase. The aileron aerodynamic control slowly operates to reduce the gust torque. The gust ends and the system speed and power slightly undershoots the initial conditions with a smooth well-behaved return in about a minute. The gust is modeled as fully immersing the rotor, which is a more severe than could occur in the field.

The effect of wind turbulence is shown in Figure 12. A steady oscillation of system speed and output power of about 10% peak to peak is predicted. This could be reduced by decreasing the slope of the speed-torque control characteristic.

#### CONCLUSIONS

A variable speed generator provides several benefits for the MOD-5A;

1. Back torque for shutdown assistance
2. Control of drivetrain dynamics
3. Starting assistance in low winds
4. Operating speed flexibility
5. Reactive power control

Either an LCI or a Scherbiustat variable speed subsystem will meet the MOD-5A technical requirements. A Scherbiustat was selected on cost. Utility preference and site specific analysis issues remain open.

#### ACKNOWLEDGEMENTS

The author gratefully appreciates the support and review provided by Len Gilbert, Frank Brady, and Francis Rooker of NASA and the technical support supplied by Mal Horton and Chuck Mayer of GE.

#### REFERENCES

1. Barton, R.S., Lucas, W.C. "Conceptual Design of the 6 MW MOD-5A Wind Turbine Generator", Proceedings of the Fifth Biennial Wind Energy Conference and Workshop, SERI/CP-635-1340, Vol 1, pp. 157-168, October 1981.
2. Bose, B.K., A Review of AC Drives Technology, TIS 81CRD127, GE, Schenectady, N.Y., June 1981 (good bibliography).
3. Lipo, T.A., Investigation of Variable Speed for Wind Turbine Power Generation, ECE-81-9, Department of Electrical and Computer Engineering, University of Wisconsin-Madison, August 1981.
4. Anderson, T.S., Hughes, P.S., Kirschbaum, H.S., Mutone, G.A., "Multiple and Variable Speed Electrical Generator Systems for Large Wind Turbines", Proceedings of Workshop held in Cleveland, Ohio, July 28-30, 1981, NASA Conference Publication 2230, DOE CONF-810752, SERI/CP-635-1273, pp. 125-138.
5. Douglas, R.R., "Conceptual Design of the 7 MW MOD-5B Wind Turbine Generator", Proceedings of the Fifth Biennial Wind Energy Conference and Workshop, SERI/CP-635-1340, Vol 1, pp. 169-182, October 1981.
6. Schwerhardt, H., Suchanek, V. "Converter-Fed Synchronous Generator Systems for Wind Power Plants", Brown-Boveri Review, Volume 69, pp. 57-64, Baden, Switzerland, March 1982.
7. Appiarius, J.C., Urano, A.S., System Benefits and Considerations when Using AC Adjustable Frequency Drives in Generating Stations, Presented at American Power Conference, Chicago, Illinois, April 27-29, 1981.
8. Mayer, C.B., "High Response Control of Stator Watts and Vars for Large Wound Rotor Induction Motor Adjustable Speed Drives", IEEE Transactions IAS79:27F, pp. 817-823.
9. Allen, J.A., Wyeth, W.A., Herzog, G.W., Young, J.A.I., "Electrical Aspects of the 8750 hp Gearless Ball-Mill Drive at St. Lawrence Cement Company", IEEE Transactions on Industry Applications VOL IA-11 No. 6, pp. 681-687, Nov/Dec 1975.
10. Guide for Harmonic Control and Reactive Compensation of Static Power Converters, IEEE 579, July 1979.
11. Pelly, B.R., Thyristor Phase-Controlled Converters and Cycloconverters, Wiley-Interscience, 1971.

Table 1- Variable Speed Subsystem Requirements

3.1	Subsystem Definition
3.1.1	General Description
3.1.2	Subsystem Configuration
3.1.3	Interface Definition
3.1.3.1	Generator Mechanical Interfaces
3.1.3.2	Generator Electrical Interfaces
3.1.3.3	Converter Mechanical Interfaces
3.1.3.4	Converter Electrical Interfaces
3.1.4	Operational Description
3.1.4.1	Duty Cycle Description
3.1.4.2	Operational Power - Power Description
3.2	Characteristics
3.2.1	Generator
3.2.1.1	Generator Characteristics
3.2.1.2	Generator Parameters
3.2.1.3	Generator Environmental Conditions
3.2.2	Converter
3.2.2.1	Characteristics
3.2.2.2	Converter Parameters
3.2.2.3	Converter Environmental Conditions
3.2.2.4	Converter Control
3.2.2.4.1	General
3.2.2.4.2	Control Modes
3.2.2.4.2.1	Initialization
3.2.2.4.2.2	Motoring
3.2.2.4.2.3	Synchronization
3.2.2.4.2.4	Torque Regulation
3.2.2.4.2.5	Reactive Power Regulation
3.2.2.4.2.6	Shutdown
3.2.2.4.2.7	Fault Monitoring

Table 2- Generator Requirement Summary

- 5000/7500 KW @ 960/1440 RPM
- 38,500 FT-LB AIR GAP TORQUE
- CLASS F INSULATION (105°C OVER 40°C)
- 4160 V<sub>L-L</sub> - EXTERNAL WYE
- 7° INCLINATION
- SELF LUBE JOURNAL BEARINGS WITH PROVISION FOR EXTERNAL FLOOD LUB.
- MOTOR 0 TO 300 RPM/GENERATE 960 TO 1440 RPM - 1700 RPM MECH OVERSPEED
- LOSSES 100 KW/300 KW @ NL/FL
- OPERATING TEMP - -20 TO + 40°C
- NON OPERATING TEMP - -40 TO + 50°C
- 3300 FT ELEV / 7000 FT ELEV WITH DERATING
- SALT AIR

Table 3- Evaluation Criteria And Weight

<u>CRITERION</u>	<u>WEIGHTING</u>
1. <u>Compatibility</u> - With Wind Turbine application and control system.	High (20%)
2. <u>Quality of Power Output</u> - Risk or degree of margin in meeting power quality requirements.	High (15%)
3. <u>Reliability</u> - Potential impact on WTG availability including effect of single failure modes.	High (15%)
4. <u>Product Maturity/Prototype Risk</u> - Confidence that system will work and perform as advertised on Prototype.	High (15%)
5. <u>Maintainability</u> - Ease of maintenance and trouble shooting.	Med. (10%)
6. <u>Customer Technology Acceptance</u> - Preferences/biases of utility customers.	Med. (10%)
7. <u>Life</u> - Probability of 30 year life.	Med. (10%)
8. <u>Schedule</u> - Prototype delivery schedule	Low (5%)
	100%

Table 4- Evaluation Comparison

COMPARISON OF LCI/SYNCHRONOUS MACHINE  
WITH CYCLOCONVERTER/WOUND ROTOR INDUCTION MACHINE  
(1 = POOR, 3 = AVERAGE, 5 = OUTSTANDING)

	(1) CYCLO/INDUC.	(2) LCI/SYNCH.	COMMENT
PERFORMANCE UNDER SINGLE PHASE FAULTS	3	5	1
PERFORMANCE UNDER THREE PHASE FAULTS	5	5	2
PERFORMANCE UNDER LINE SURGES	5	3	3
CONTROL RESPONSE	5	3	4
STARTING PERFORMANCE AS MOTOR	4	3	5
POWER FACTOR CONTROL	5	4	6
TORQUE HARMONICS DURING RUNNING	3	4	7
TORQUE HARMONICS DURING STARTING	4	3	7
HARMONIC FILTER REQUIREMENTS	3	4	8
MAINTENANCE	4	5	9
CIRCUIT COMPLEXITY	3	3	
	44	42	

COMMENTS:

1. COULD RESULT IN DE-EXCITATION OF MACHINE IN (1).
2. BOTH CAN PROVIDE RAPID RECLOSE AFTER THREE PHASE FAULT.
3. LINE SURGES COULD RESULT IN COMMUTATION FAILURES IN (2). CYCLO IS BUFFERED BY AN EXTRA TRANSFORMER.
4. CURRENT IN DAMPER WINDINGS IN (2) OPPOSE RAPID CHANGES IN TORQUE WITHOUT MORE ELABORATE CONTROL SCHEMES (FIELD ORIENTED CONTROL).
5. HIGHER STARTING TORQUE AVAILABLE FROM CYCLO WHEN CONNECTED TO THE STATOR OF THE MACHINE FOR STARTING. WHEN USING (1) AVAILABLE STARTING TORQUE IS PROPORTIONAL TO CYCLOCONVERTER RATING, USING (2) IT DEPENDS UPON SIZE OF LINK INDUCTOR AND LIMITED TYPICALLY TO A SMALL FRACTION OF RATED TORQUE (ABOUT 0.1 PU).
6. POWER FACTOR CONTROL IS INHERENT IN THE CONTROL OF THE CYCLO. POWER FACTOR CONTROL WITH (2) COMES WITH CAREFUL PHASE SHIFTING OF THE UTILITY SIDE BRIDGE IN CONJUNCTION WITH A BANK OF CAPACITORS (NOT NEEDED IN (1)).
7. TORQUE HARMONICS OF (1) ARE MORE SEVERE DURING RUNNING IN THAT THEY TEND TO BE MORE RANDOM AND THEREFORE LESS PREDICTABLE. TORQUE HARMONICS OF (2) ARE MORE SEVERE DURING STARTING DUE TO THE MODULATION OF THE DC LINK CURRENT TO ACHIEVE COMMUTATION OF THE MACHINE SIDE BRIDGE AT LOW ROTATIONAL SPEED.
8. HARMONIC FILTERING IS MORE DIFFICULT WITH (1) DUE TO THE MORE RAND NATURE OF THE HARMONICS.
9. MAINTENANCE IS A SMALL BUT NOTEWORTHY PROBLEM WITH (1).

Table 5- Power Quality

HECO/GE  
(UNDER MEASUREMENT  
CONDITIONS MUTUALLY  
AGREED TO BY GE & HECO)

VOLTAGE	- 46KV ±5% 3φ, 60 HZ
SUPERIMPOSED VOLTAGE	- NOT TO EXCEED 2V ON 115V SYSTEM
FREQUENCY	- ± 0.1 HZ NORMAL ± 0.4 HZ ABNORMAL 3 PER DAY
LINE NOTCHING	- 17500 VμS 5% D.F.
HARMONICS	- FILTER TO < 5% (46KV)
TELEPHONE (TIF)	- I*T COORDINATION WITH TELEPHONE COMPANY
FLICKER	- FIX IF OCCURS
PF CORRECTION	- NEAR 1.0 PF, VAR REGULATE WITH FILTER, PF CAPS

IEEE 519  
(GUIDELINES)

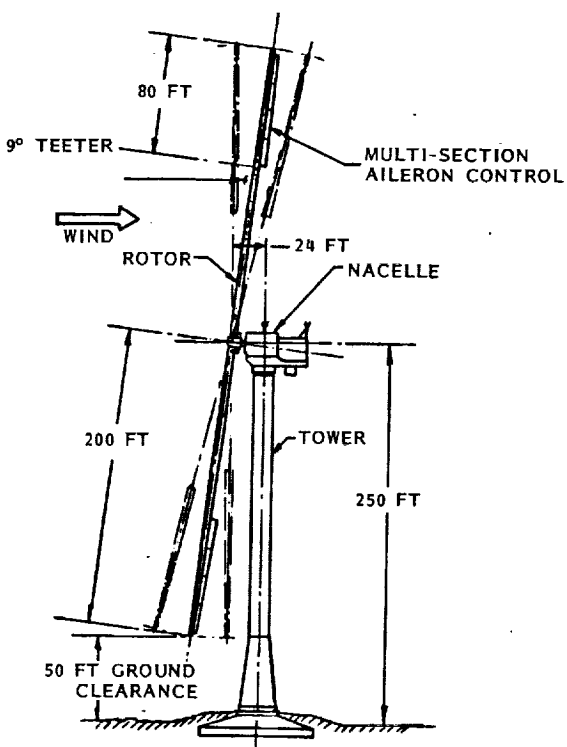

OPERATIONAL CHARACTERISTICS

RATED POWER	7300 KW AT 0.98PF
RATED WIND SPEED	32 MPH AT 250 FT
CUT-IN/CUT-OUT WIND SPEED	14/60 MPH AT 250 FT
MAXIMUM WIND SPEED (SURVIVAL)	130 MPH AT 250 FT
POWER CONTROL	MULTI-SECTION AILERONS
ROTOR RPM-SET SPEED	13.7/16.8 RPM (± 10%)
ENERGY CAPTURE/YR	21.3 X 10 <sup>6</sup> KWH (NASA SPECIFIED WIND SPEED DURATION CURVE, 14 MPH AT 32 FT, 100 % AVAIL)
TOTAL WT ON FOUNDATION	1804 K-LB

FEATURES

- WOOD LAMINATE BLADES WITH HIGH PERFORMANCE AIRFOIL - UPWIND, TEETERED
- NON-ROTATING ROTOR SUPPORT
- HYBRID EPICYCLIC/PARALLEL SHAFT GEARBOX
- VARIABLE SPEED/CONSTANT FREQUENCY OPERATION, WITH 2 SET POINTS
- SOFT SHELL TOWER, TUNEABLE BELL SECTION

Figure 1- MOD-5A System Model 304.2

**MAJOR SUBASSEMBLIES**

- GENERATOR
- YAW SLIP RING ASSEMBLY
- POWER CABLING
- CONVERTER
- SWITCHGEAR
- STEP-UP TRANSFORMER
- STATION BATTERIES

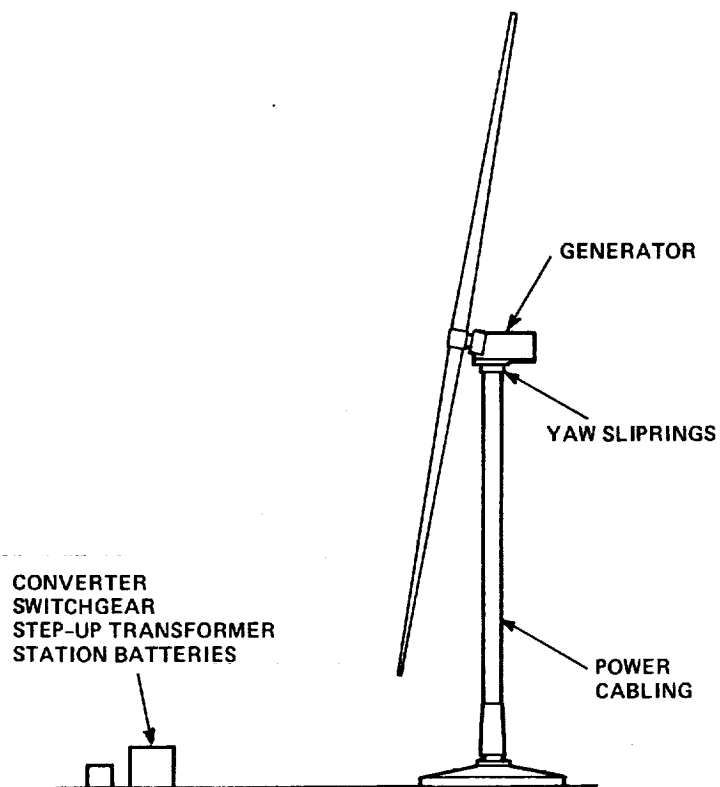

Figure 2- Generator Subsystem Equipment Locations

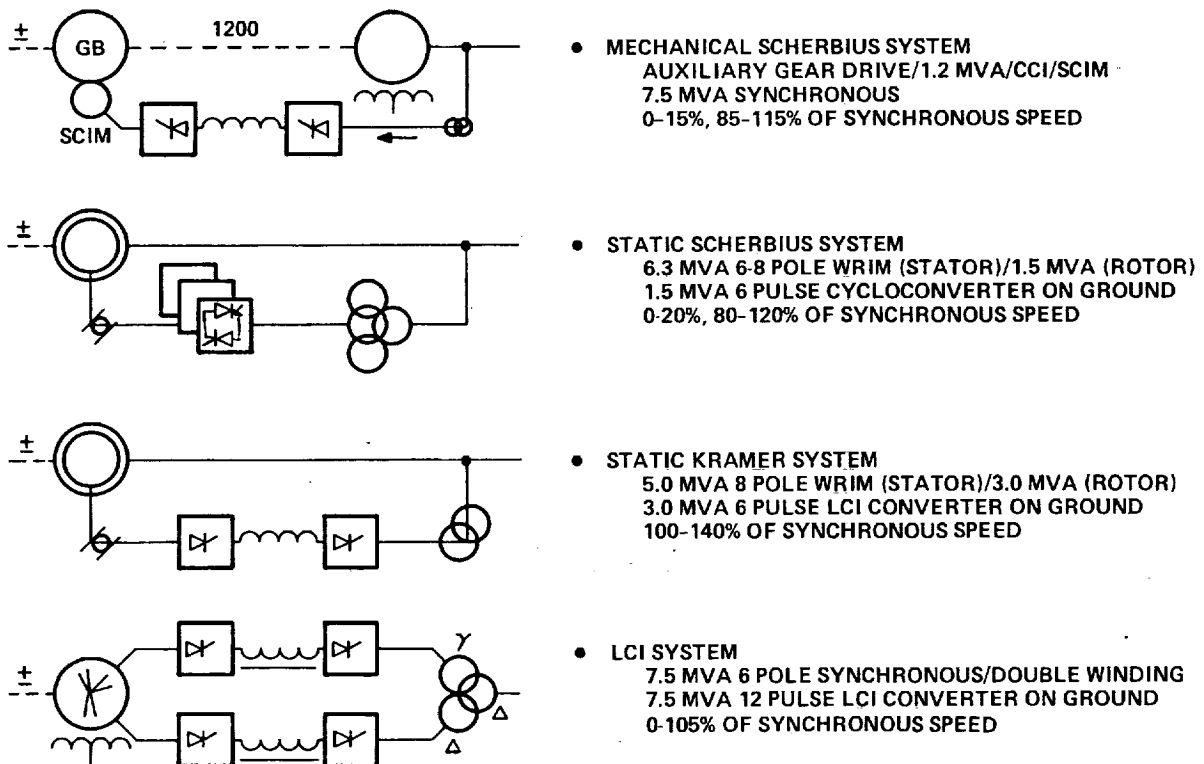

Figure 3- Variable Speed Configurations

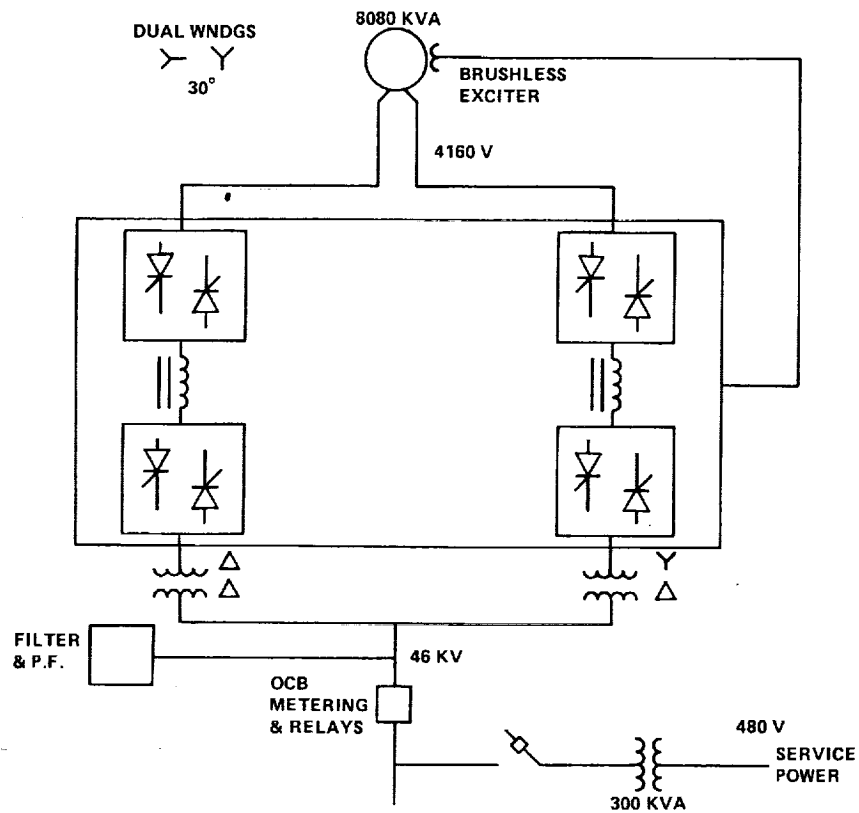
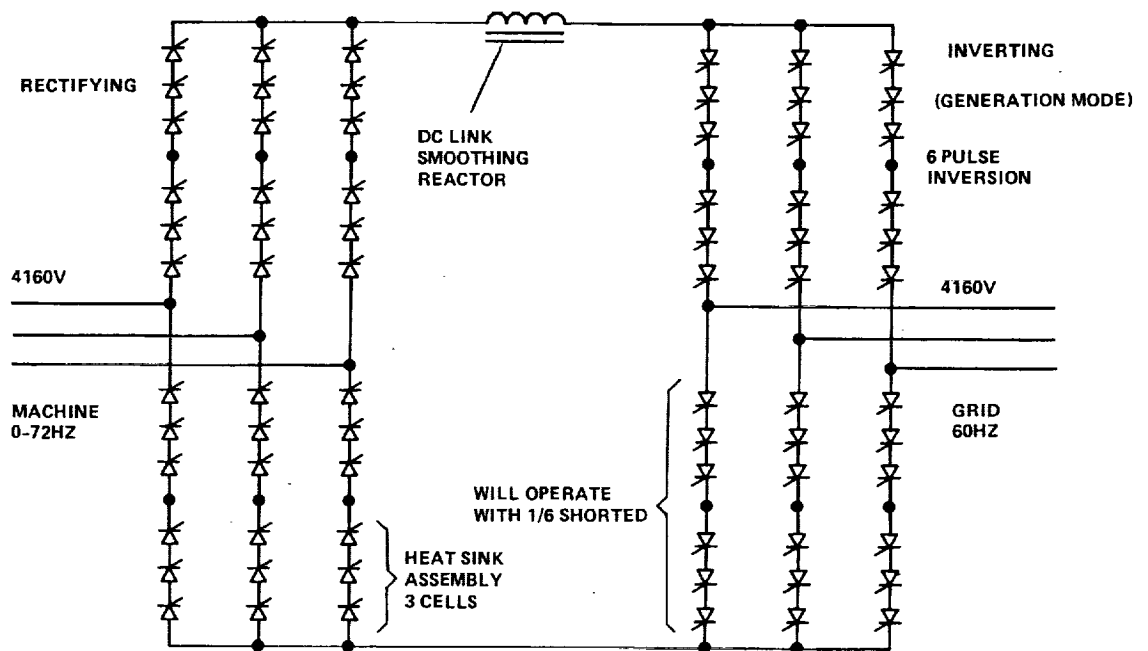

Figure 4- LCI Subsystem Arrangement



CONVERTER 4040 KVA (HALF OF LCI CONFIGURATION)

SHOWN: 24 HEAT SINK ASSEMBLIES, 72 CELLS

TOTAL SYSTEM: 48 HEAT SINK ASMS., 144 CELLS

FULL CONVERTER & REACTORS: 50' LONG x 5' DEEP x 7-1/2' HIGH; 20,000# APPROX

REF: GEA 10816

Figure 5- LCI Converter Detail



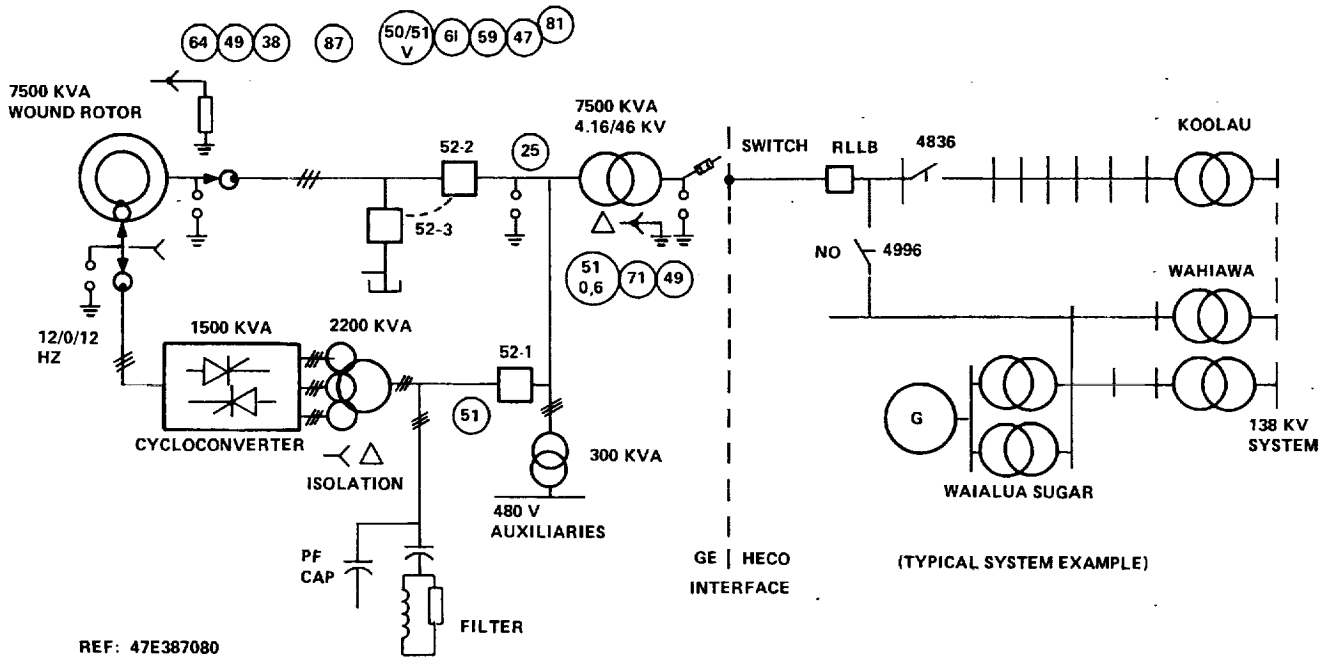

Figure 6- Scherbiustat Subsystem Arrangement

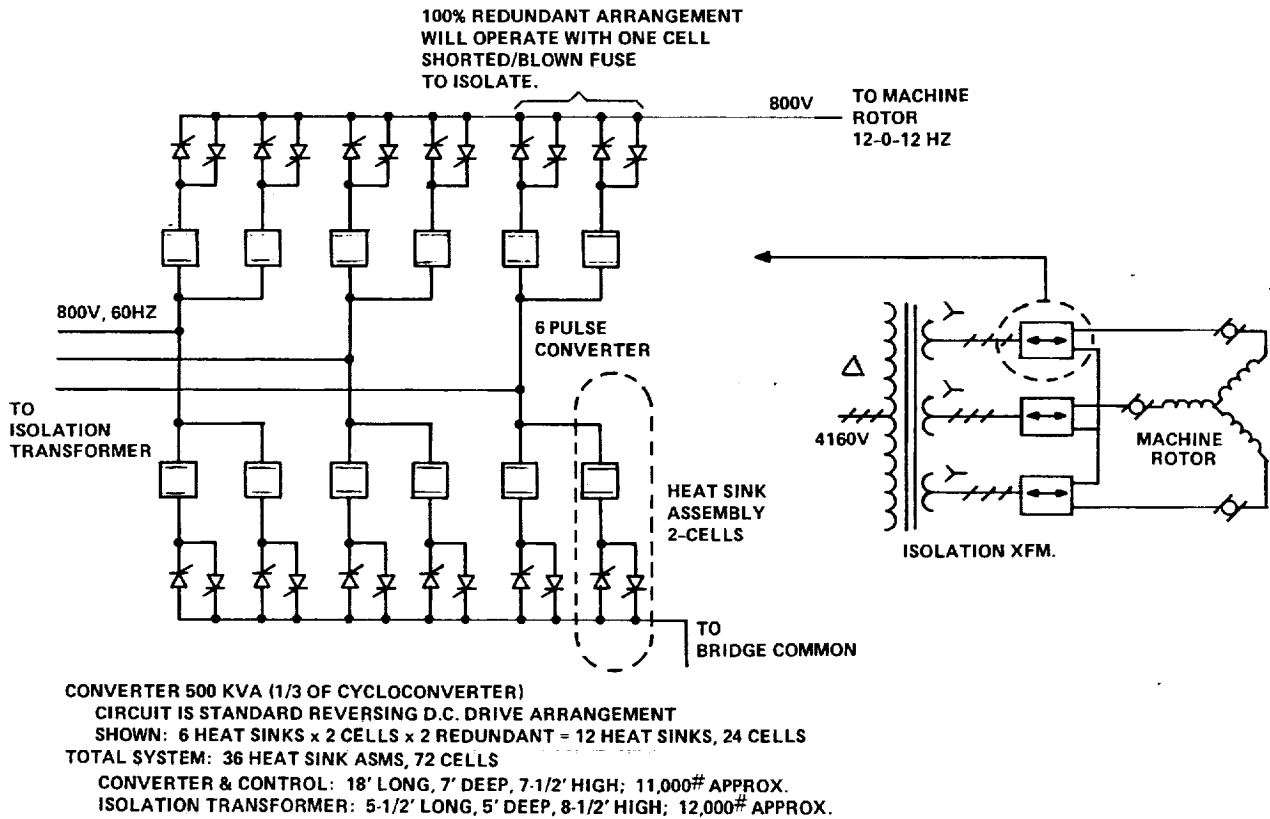

Figure 7- Scherbiustat Converter Detail

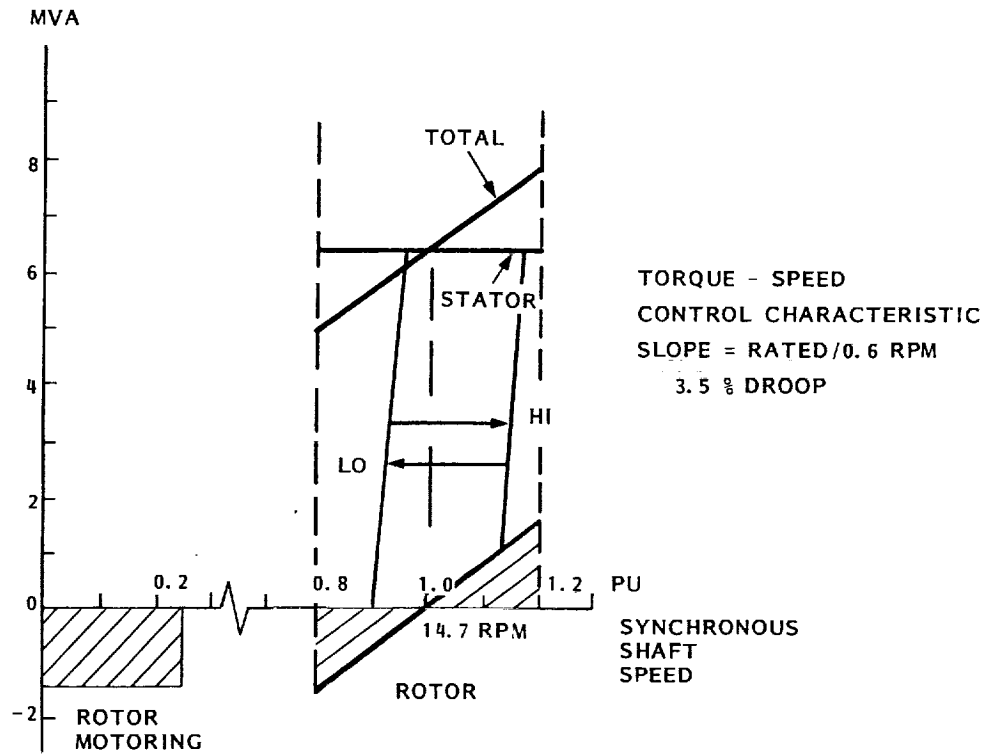

Figure 8- Generator Operating Regime

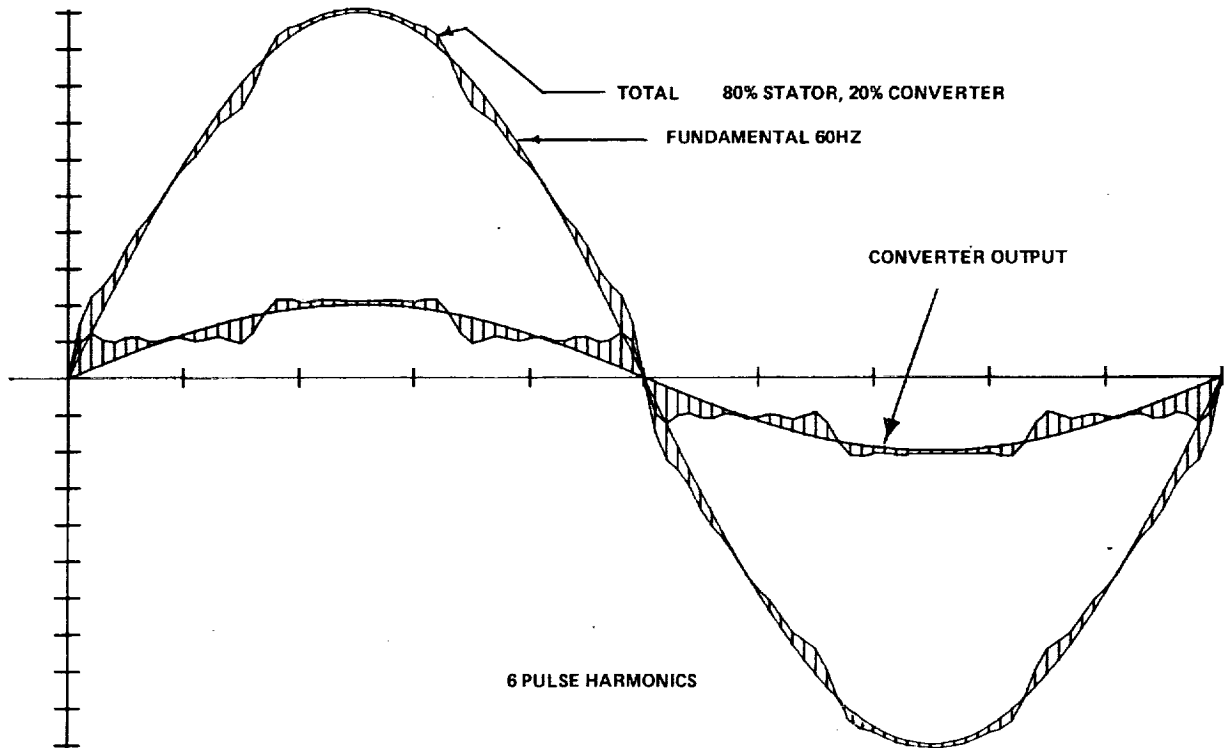
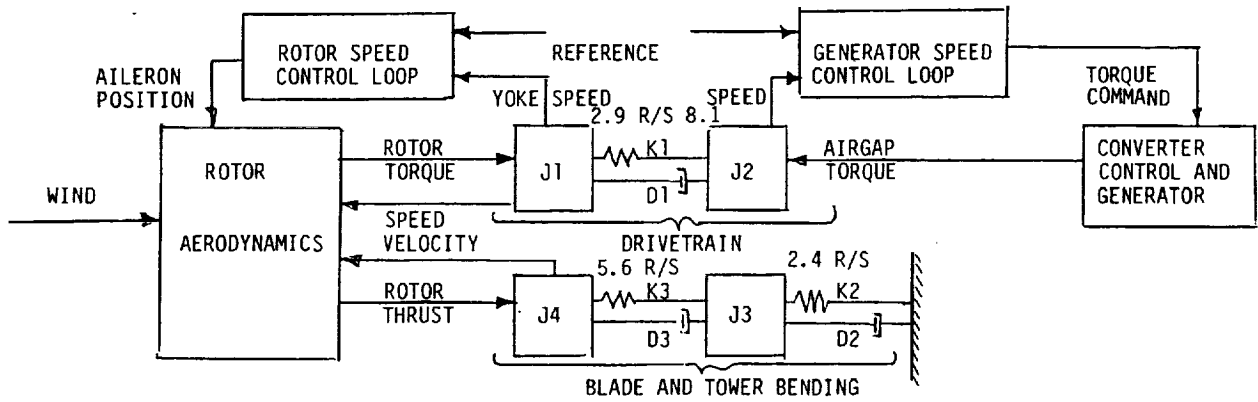

Figure 9- Harmonic Distortion



- |   |  |
|---|--|
| J1 = Rotor Inertia  | $40 \times 10^6$ slug-ft <sup>2</sup>                      |
| J2 = Generator & High Speed Shaft, Inertia reflected to Rotor | $(745+30)(82.14)^2 = 5.2 \times 10^6$ slug-ft <sup>2</sup> |
| J3 = Tower Mass   | $2.9 \times 10^4$ slug                                     |
| J4 = Blade Flap Mass  | $1.06 \times 10^3$ slug                                    |
| K1 = Drivetrain Spring Constant                               | $3.38 \times 10^8$ ft-lb/rad                               |
| K2 = Tower Spring Constant                                    | $1.674 \times 10^5$ lbs/ft                                 |
| K3 = Blade Flap Spring Constant                               | $3.370 \times 10^4$ lbs/ft                                 |
| D1 = Drivetrain Damping Coefficient                           | $3.0 \times 10^6$ ft-lb/(rad/sec)                          |
| D2 = Tower Damping Coefficient                                | 6968 lb/(ft/sec)   |
| D3 = Blade Flap Damping Coefficient                           | 3785 lb/(ft/sec)   |

Figure 10- Simulation Model Block Diagram

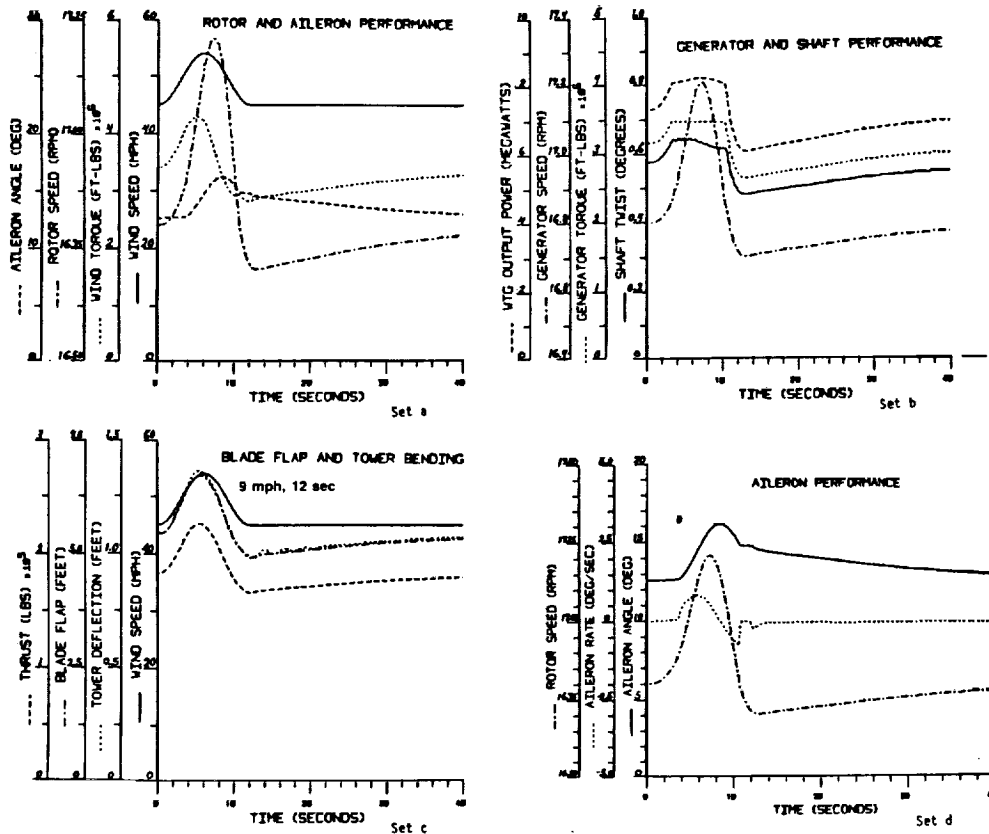

Figure 11- Response To 1-Cosine Wind Change

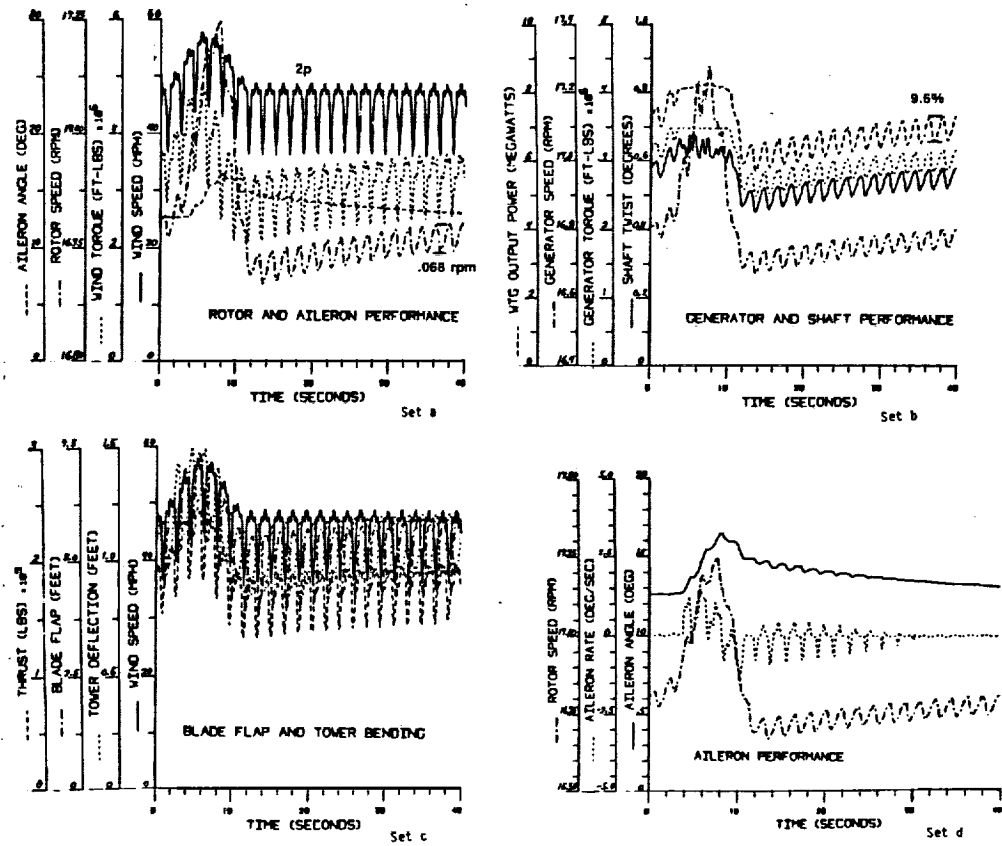

Figure 12- Response To 1-Cosine Wind Change With Turbulence