

51310
P-55



**BENEFITS AND LIMITATIONS OF
COMPOSITES IN CARRIER-BASED AIRCRAFT**



**NINTH DOD/NASA/FAA CONFERENCE ON
FIBROUS COMPOSITES IN STRUCTURAL DESIGN**

**DR. D. McERLEAN
NAVAL AIR DEVELOPMENT CENTER**

UNIQUE ASPECTS OF NAVAL AIR MISSIONS

THERE ARE MANY UNIQUE ASPECTS OF NAVY AIR MISSIONS THAT LEAD TO THE DIFFERENTIATION BETWEEN THE DESIGN AND PERFORMANCE OF SHIP AND SHORE-BASED AIRCRAFT. WE SHALL DISCUSS THE MAJOR UNIQUE ASPECTS FROM WHICH ESSENTIALLY ALL NAVY AIRCRAFT DESIGN REQUIREMENTS DERIVE.

FIRST: THE FACT THAT NAVY AIRCRAFT OPERATE FROM CARRIERS AT SEA IMPOSES A BROAD SPECTRUM OF PHYSICAL CONDITIONS, CONSTRAINTS AND REQUIREMENTS RANGING FROM THE HARSH AT-SEA ENVIRONMENT, THE SPACE LIMITATIONS OF A CARRIER, TAKE-OFF AND LANDING REQUIREMENTS AS WELL AS A NEED FOR ENDURANCE AT LONG DISTANCES FROM THE CARRIER.

SECOND: BECAUSE THE CARRIER AND ITS AIRWING ARE INTENDED TO BE CAPABLE OF RESPONDING TO A BROAD RANGE OF CONTINGENCIES RANGING FROM CONFRONTATION WITH A MAJOR POWER TO PROVIDING PRESENCE IN THIRD WORLD AREAS, MISSION FLEXIBILITY IS ESSENTIAL. CARRIER BASED AIRCRAFT MUST HAVE MAXIMUM WEAPON CARRIAGE OPTIONS TO MEET CHANGING OR UNKNOWN THREATS, THEY MUST BE CAPABLE OF RAPID RECONFIGURATION, AND MUST HAVE MULTIPLE MISSIONS CAPABILITY TO HANDLE ALL CONTINGENCIES ONCE AIRBORNE.

THIRD: THE EMBARKED AIRCRAFT PROVIDES THE LONG RANGE DEFENSE OF THE BATTLE GROUP AGAINST AIR, SURFACE AND SUBSURFACE LAUNCHED ANTISHIP MISSILES. ALL CAPABILITY MUST BE ORGANIC TO THE BATTLE GROUP.

FOURTH: THE CARRIER AND ITS AIRCRAFT MUST OPERATE INDEPENDENTLY AND OUTSIDE OF NORMAL SUPPLY LINES ANYWHERE ON THE GLOBE. THEREFORE SELF SUFFICIENCY IS ESSENTIAL.



UNIQUE ASPECTS OF NAVAL AIR MISSIONS



- **AT SEA/SHIPBOARD OPERATIONS**
- **MISSION FLEXIBILITY**
- **SELF-DEFENSE/FLEET DEFENSE A REQUIREMENT**
- **SELF SUFFICIENCY A REQUIREMENT**

NAVAL AIRCRAFT OPERATIONAL ENVIRONMENT

CLEARLY, THE AT-SEA ENVIRONMENT PROVIDES A SIGNIFICANT DIFFERENCE IN AIR OPERATIONS FOR THE NAVY. THE PHOTOGRAPH SHOWS A BOW WAVE ENGULFING AIRCRAFT POSITIONED ON A CARRIER DECK. THIS CORROSIVE ENVIRONMENT REQUIRES MAJOR DIFFERENCES IN MATERIALS AND COATINGS FOR NAVY AIRCRAFT.



SIZE & WEIGHT LIMITS

SIZE LIMITATIONS

- THE CATAPULT TAKEOFF IMPOSES HARD LIMITS ON THE OVERALL LENGTH OF THE AIRPLANE AND THE MINIMUM HEIGHT ABOVE GROUND FOR THE FUSELAGE AND ANY OF ITS ATTACHMENTS, SUCH AS CENTERLINE TANKS OR WEAPONS.
- THE FLIGHT DECK GEOMETRY LIMITS THE WINGSPAN (OR ROTOR DIAMETER).
- THE ELEVATORS REQUIRE THAT HINGES FOR FOLDING THE AIRCRAFT BE EMPLOYED WITH POWER ACTUATION.
- THE HANGAR DECK IMPOSES A HEIGHT LIMIT TO THE VERTICAL TAIL OR TAIL ROTOR, IN THE FOLDED POSITION.

WEIGHT LIMITATIONS

- THE TAKEOFF WEIGHT, FULLY LOADED, IS LIMITED BY THE CAPACITY OF THE CATAPULT (90,000 #).
- THE LANDING WEIGHT, WITH RESERVE FUEL AND UNFIRED WEAPONS, IS LIMITED BY THE ARRESTING GEAR CAPACITY (65,000 #).



SIZE & WEIGHT LIMITS



- CATAPULT LAUNCH
 - OVERALL LENGTH (NOSE TO TAILPIPE)
 - GROUND CLEARANCE HEIGHT
- FLIGHT DECK GEOMETRY
 - WINGSPAN LIMITED FOR CLEARANCE
 - ROTOR DIAMETER ALSO LIMITED FOR CLEARANCE ON SMALLER SHIPS
- ELEVATORS
 - FOLD WINGS, TAILS, NOSE, ROTORS TO FIT (2) AIRCRAFT ON ELEVATOR
- HANGAR DECK
 - HEIGHT OF TAIL, FOLDED WINGS, OR TAIL ROTOR MUST CLEAR OVERHEAD SHIP FRAMES
- TAKEOFF & LANDING WEIGHT
 - THROW CAPACITY OF CATAPULT
 - ENERGY ABSORPTION OF ARRESTING GEAR

NAVY STRUCTURES REQUIREMENTS/CONSTRAINTS

THE DESIGN OF THE STRUCTURE IS DRIVEN BY THE LARGE LANDING SINK RATES AND THE CATAPULT AND ARRESTED LANDING LOADS IMPOSED ON THE AIRFRAME, BOTH STATICALLY AND IN FATIGUE. THE MAGNITUDE AND LOCATION OF THE LOADS INFLUENCE STRUCTURAL CONFIGURATION, LOAD DISTRIBUTION AND MATERIAL SELECTION. THESE HIGHER LOADS IMPOSE SEVERE WEIGHT PENALTIES ON CARRIER BASED AIRCRAFT COMPARED TO LAND BASED AIRCRAFT.

THE SHIPBOARD ENVIRONMENT IMPOSES SEVERE REQUIREMENTS IN AIRFRAME MATERIALS USAGE AND SUPPORTABILITY ISSUES. THE LOGISTICS CONSTRAINTS FOR CARRIER OPERATIONS BEING MUCH MORE SEVERE THAN FOR LAND BASED OPERATIONS, IMPOSE UNIQUE REQUIREMENTS FOR SUPPORTABILITY OF AIRFRAMES. REPAIR MATERIALS REQUIRE LONG SHELF LIFE AT AMBIENT TEMPERATURES. REPAIR PROCEDURES MUST BE COMPATIBLE WITH EQUIPMENT AND FACILITIES ON-BOARD, AND WITHIN THE CAPABILITIES OF FLEET PERSONNEL.

DUE TO THE LIMITED SPACE AVAILABLE BOTH ON THE FLIGHT AND HANGER DECKS, AS WELL AS ELEVATORS, NAVY AIRCRAFT TYPICALLY INCLUDE MECHANISMS TO FOLD OR STOW WINGS, ROTOR BLADES AND TAILS. THE V-22, FOR EXAMPLE, INCORPORATES MECHANISMS TO FOLD ROTOR BLADES, TILT THE NACELLES AND ROTATE THE WING TO A POSITION PARALLEL TO THE FUSELAGE.

VSTOL AIRCRAFT (SUCH AS THE AV-8B) ALSO ENCOUNTER ELEVATED TEMPERATURES AT VARIOUS LOCATIONS ON THE STRUCTURE DUE TO IMPINGEMENT OF HOT EXHAUST GASES FROM THE ENGINE NOZZLES. THIS HAS REQUIRED THE APPLICATION OF SPECIALITY MATERIALS AND HAS RESULTED IN SERVICE PROBLEMS WHICH WILL BE DISCUSSED LATER.

THE MISSIONS FOR CARRIER BASED AIRCRAFT IMPOSE UNIQUE FLIGHT ENVELOPES, FATIGUE SPECTRA, FATIGUE LIFE TRACKING METHODOLOGY, DAMAGE TOLERANCE CRITERIA AND CERTIFICATION REQUIREMENTS. THESE REQUIREMENTS HAVE LEAD TO THE EVOLUTION OF NAVY DESIGN PHILOSOPHY, CRITERIA, AND CERTIFICATION PROCEDURES. THIS PHILOSOPHY AND CRITERIA ARE SPECIFICALLY USED IN ALL PROGRAMS ADDRESSING STRUCTURAL INTEGRITY ISSUES FOR NAVY/MARINE AIRFRAMES. "TOUGH ENVIRONMENTS REQUIRE TOUGH CRITERIA."



NAVY STRUCTURES REQUIREMENTS/CONSTRAINTS



- HIGH SINK RATES
- CATAPULT AND ARREST REQUIREMENTS
- MAINTENANCE LOGISTICS AND SUPPORT EQUIPMENT
- MAINTENANCE AND INSPECTION PROCEDURES
- FOLDING STRUCTURE
- STRUCTURAL TEMPERATURES
- DESIGN PHILOSOPHY AND CRITERIA
- TESTING AND CERTIFICATION REQUIREMENTS
- AIRCRAFT USAGE
- FATIGUE LIFE TRACKING METHODOLOGY

GROUND LOADS COMPARISON CARRIER VS. SHORE BASED

THIS FIGURE DRAMATICALLY ILLUSTRATES THE SIGNIFICANT DESIGN LOAD REQUIREMENTS FOR A TYPICAL NAVY CARRIER BASED AIRCRAFT COMPARED TO A SHORE BASED AIRCRAFT.



GROUND LOADS COMPARISON CARRIER VS. SHORE BASED

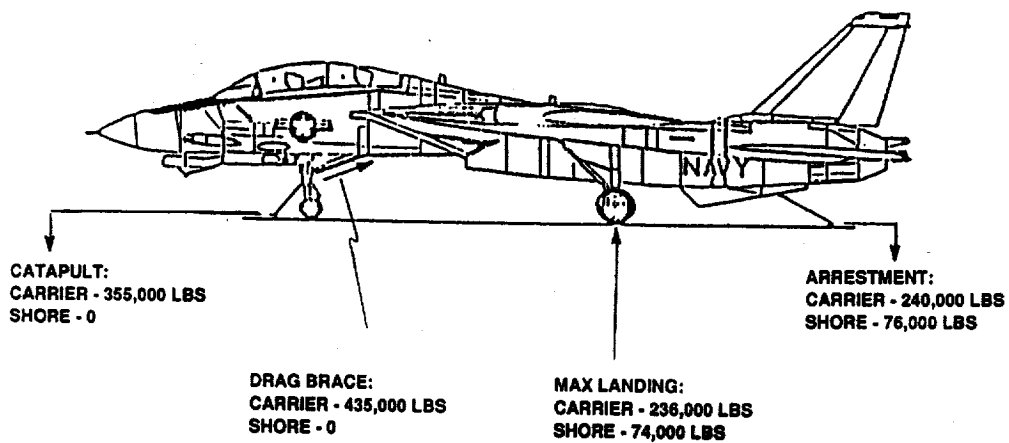



NAVY COMPOSITE STRUCTURES EXPERIENCE

THE NAVY HAS 20 YEARS OF COMPOSITE EXPERIENCE. THE NAVY INITIATED THE USE OF ADVANCED COMPOSITES IN PRODUCTION AIRCRAFT DURING THE EARLY 70'S WITH THE USE OF F-14 STABILATORS WITH BORONEPOXY SKINS OVER A FULL DEPTH HONEYCOMB CORE. DURING DEVELOPMENT OF SUBSEQUENT AIRCRAFT, THE USE OF COMPOSITES INCREASED. THE F-18 DESIGN INCORPORATED GRAPHITE/EPOXY WING SKINS AND HORIZONTAL AND VERTICAL TAILS. THIS WAS A VERY CONSERVATIVE USE OF COMPOSITES. THE PROGRAM SCHEDULE ALSO ALLOWED TIME FOR REDESIGN SHOULD A MAJOR TEST FAILURE OCCUR IN THE COMPOSITE SKINS. THE AV-8B DESIGN WAS MORE AGGRESSIVE IN THE USE OF COMPOSITES AND THE FIRST ALL COMPOSITE WING, FORWARD FUSELAGE AND HORIZONTAL STABILATOR WERE INCORPORATED FOR PRODUCTION. IN THIS AIRCRAFT, THE USE OF COMPOSITES PERMITTED INCORPORATION OF A 15% LARGER SUPERCRITICAL WING WITH A MODERATE WEIGHT SAVINGS OVER THE ORIGINAL METAL AV-8A WING. RECENTLY, THE A-6 RE-WING EFFORT RESULTED IN EXTENSIVE USE OF GRAPHITE FOR THE WING SKINS AND MUCH OF THE SUBSTRUCTURE TO MEET INCREASED FATIGUE AND LOAD REQUIREMENTS AT NO INCREASE IN WEIGHT. AGAIN BECAUSE OF WEIGHT CRITICALITY IN A VSTOL APPLICATION, THE V-22 AIRCRAFT INCORPORATES A NEARLY ALL COMPOSITE WING AND FUSELAGE STRUCTURE.

NAVY COMPOSITE STRUCTURES EXPERIENCE

EVOLUTIONARY EXPANSION OF PRODUCTION APPLICATIONS

F-14	1%	1970
F/A-18	10%	1978
AV-8B	26%	1982
A-6 WING	38%	1988
V-22	50%	1990's

F-18 COMPOSITE STRUCTURE

GRAPHITE/EPOXY USED PRIMARILY ON WING AND STABILIZER SKINS AND CENTER FUSELAGE DORSAL FAIRING, SPEED BRAKE AND WING FLAPS.



AV-8B COMPOSITE STRUCTURE

GRAPHITE/EPOXY USED IN WING, FUSELAGE, AND TAIL STRUCTURES. WING IS MULTI-SINEWAVE SPAR/RIB SUBSTRUCTURE CONSTRUCTION. GRAPHITE/EPOXY IS ALSO USED IN THE HORIZONTAL STABILIZER AND RUDDER. GRAPHITE/BMI APPLICATIONS INCLUDE STRAKES AND LOWER SKIN OF THE MAIN FLAPS.



AV-8B HORIZONTAL STABILIZER

SKINS ARE GRAPHITE/EPOXY TAPE. SUBSTRUCTURE IS GRAPHITE/EPOXY CLOTH. SUBSTRUCTURE IS INTEGRAL WITH LOWER SKIN.

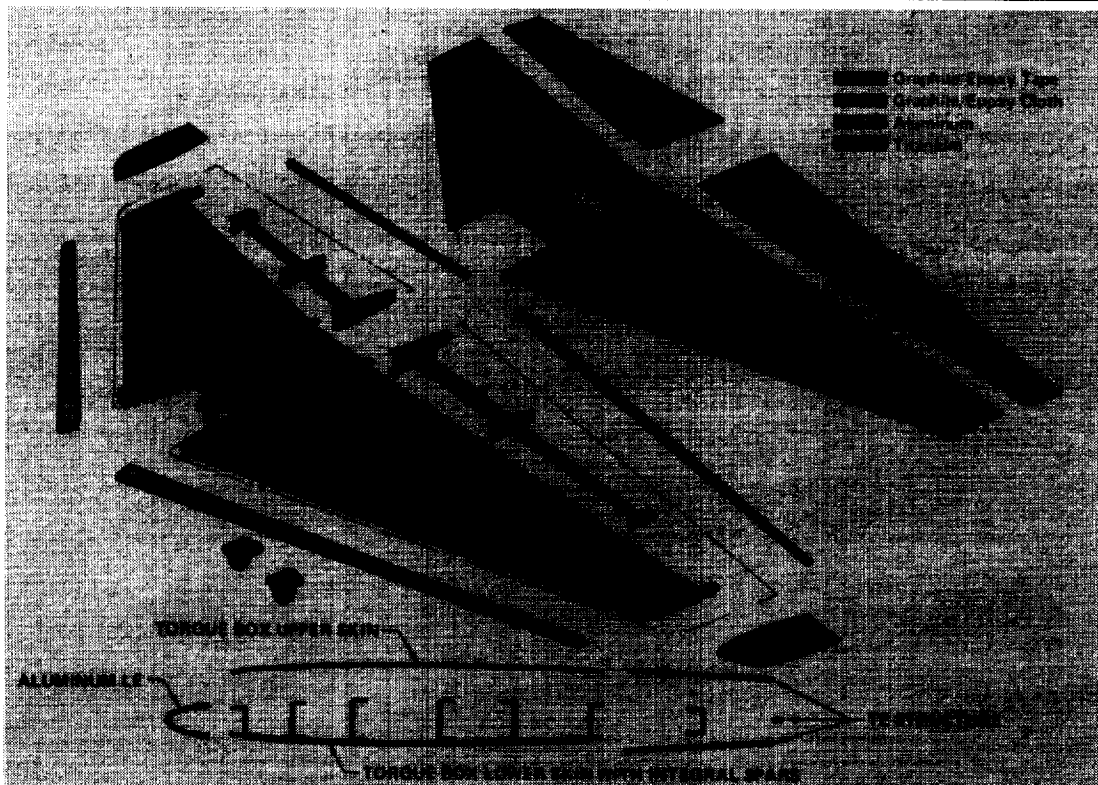

A-6 WING

GRAPHITE/EPOXY IS USED IN THE PLANKED SKINS AND INTERMEDIATE SPARS AND RIBS. ALL BOUNDARY, CLOSE-OUT SUBSTRUCTURE IS TITANIUM.

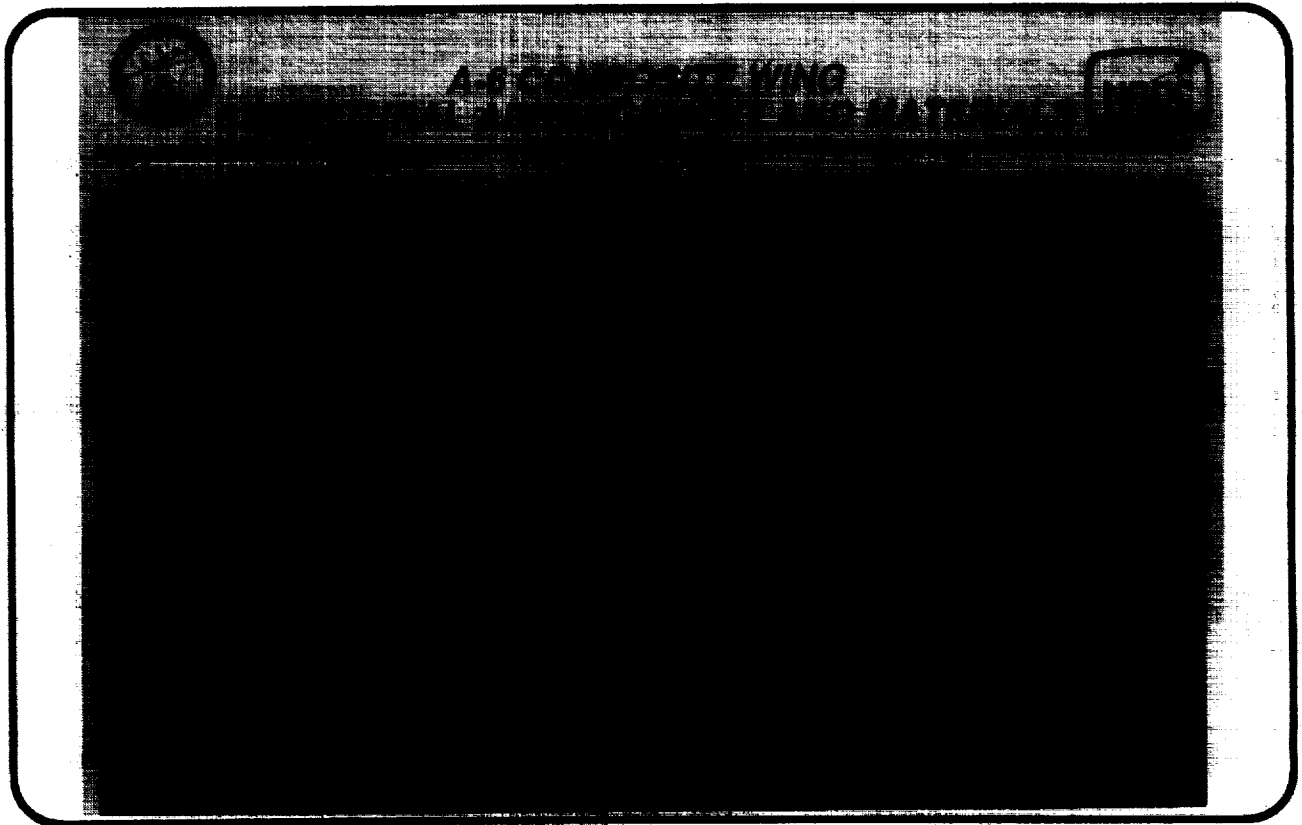

V-22 COMPOSITE STRUCTURE

GRAPHITE/EPOXY IS USED FOR THE WING AND FUSELAGE. THE WING IS PLANKED SKIN/MULTI-RIB DESIGN. ALL SPARS AND RIBS, WITH THE EXCEPTION OF THE TWO OUTBOARD RIBS, ARE GRAPHITE/EPOXY. FUSELAGE STRUCTURE IS STIFFENED SKIN. THE ROTOR GRIPS ARE FILAMENT WOUND GRAPHITE/EPOXY AND THE YOKE AND ROTOR BLADES ARE WOUND FIBERGLASS.

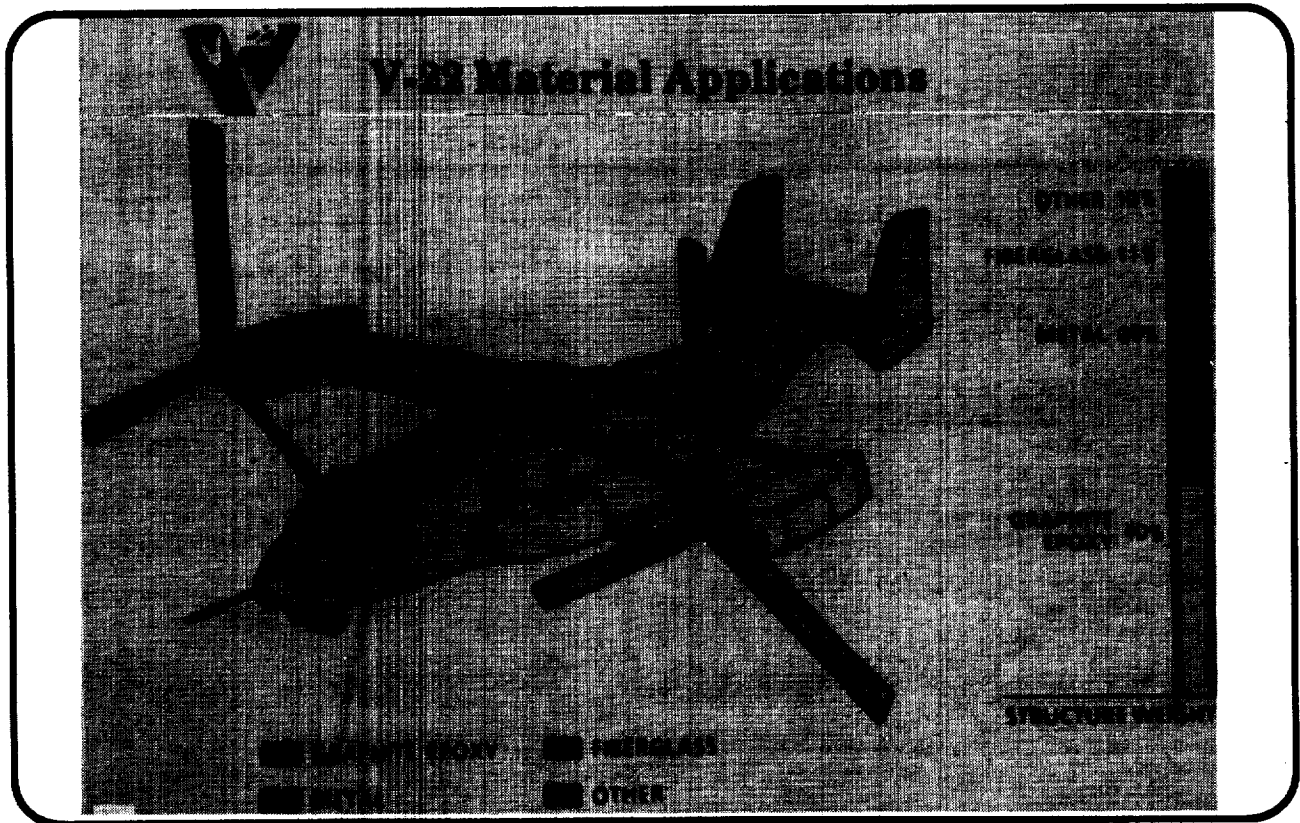

COMPOSITE USAGE IS APPROACHING STABILITY

OVER THE PAST 30 YEARS COMPOSITE USAGE AS A PERCENTAGE OF AIRCRAFT STRUCTURAL WEIGHT HAS BEEN STEADILY INCREASING FROM 1% IN THE F-14 AIRCRAFT TO 50% IN THE Y-22. IT APPEARS THAT 50% USAGE IS A MAXIMUM AND IS ONLY APPLICABLE WHERE WEIGHT SAVINGS ARE HIGHLY CRITICAL TO OPERATIONAL CAPABILITY AS IN A VSTOL AIRFRAME. IN THE FUTURE, WITH THE INCREASED EMPHASIS ON CONTROLLING COSTS, USAGE IN THE 30% TO 50% RANGE IS ANTICIPATED.



COMPOSITES USAGE IS APPROACHING STABILITY

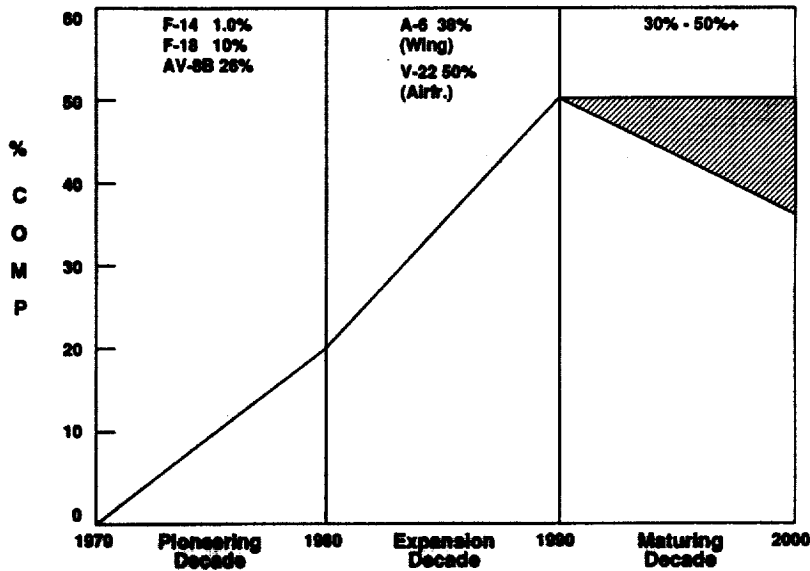

SH-60B

COMPOSITES ARE USED IN THE FOLLOWING COMPONENTS OF THE SH-60B

**MAIN ROTOR BLADES
TAIL ROTOR BLADES
CABIN FLOOR PANELS
ENGINE COWLING/WORK PLATFORM
RADOME, TRANSMISSION COWLING
TAIL ROTOR DRIVE SHAFT COVER**

THE LEADING AND TRAILING EDGES OF THE HORIZONTAL STABILIZER ARE ALL OF COMPOSITE CONSTRUCTION.

FATIGUE RESISTANCE AND CORROSION RESISTANCE WERE THE MAIN REASONS FOR CHOOSING COMPOSITES, ESPECIALLY IN THE ROTOR BLADES.



OTHER VEHICLE APPLICATIONS

COMPOSITES ARE USED IN VARIOUS APPLICATIONS ON OTHER HELICOPTER STRUCTURE. BELOW IS A LIST OF VARIOUS HELICOPTERS TOGETHER WITH COMPOSITE USAGE AND REASONS FOR ITS USE.

MAIN ROTOR BLADES - THE MAJORITY OF COMPOSITE BLADES IN USE TODAY ARE MADE WITH FIBERGLASS SKINS OVER A NOMEX HONEYCOMB CORE.

FLOOR PANELS - FIBERGLASS SKINS OVER A NOMEX HONEYCOMB CORE SUCH AS IN THE SH-60B.

IN THE MH-53E, THE COCKPIT, ENGINE AND TRANSMISSION COWLINGS, WORK PLATFORMS, PORTION OF VERTICAL STABILIZER, AND SPONSONS ARE KEVLAR WITH A REINFORCING LAYER OF GRAPHITE.

MH-53E STUB WINGS - KEVLAR SKINS WITH A REINFORCING PLY OF GRAPHITE.

CH-46 STUB WINGS - GRAPHITE/EPOXY SKINS WITH NOMEX HONEYCOMB CORE. COMPOSITE DESIGN/CONSTRUCTION ALLOWS FOR MORE FUEL VOLUME THAN TRADITIONAL METAL SKIN/STIFFENER.

COMPOSITE MATERIALS HAVE BEEN SELECTIVELY APPLIED IN OTHER CLASSES OF FLIGHT VEHICLES CURRENTLY UNDER DEVELOPMENT. THESE VEHICLES INCLUDE SMART WEAPONS (AIWS), RPV'S (PIONEER) AND AIR LAUNCHED MISSILES. FOR APPLICATIONS TO SYSTEMS OF THIS NATURE, EMPHASIS IS PLACED UPON LOW MANUFACTURING COSTS IN CONJUNCTION WITH HIGH PRODUCTION RATES. THIS LEADS TO SEMI-AUTOMATED PROCESSES SUCH AS FILAMENT WINDING, RESIN TRANSFER MOLDING AND COMPRESSION MOLDING. FATIGUE IS NOT AN ISSUE IN THESE APPLICATIONS BECAUSE OF THE VEHICLE'S SHORT SERVICE LIFE.



OTHER VEHICLE APPLICATIONS OF COMPOSITES



HELICOPTERS

SH-60B

MH-53E

AH-1

CH-46

UAV'S

AIWS

RPV'S

AIR LAUNCHED MISSILES

MAJOR BENEFITS TO NAVY

THE NAVY RECOGNIZED EARLY THAT COMPOSITES OFFERED MAJOR BENEFITS TO NAVY/MARINE AIRCRAFT OPERATING IN THE SHIPBOARD ENVIRONMENT. THE REQUIREMENT TO DEVELOP A VSTOL AIRCRAFT IN THE EARLY 70'S REINFORCED THE NEED TO USE COMPOSITES TO REDUCE THE STRUCTURAL WEIGHT FRACTIONS.

SERVICE LIFE REQUIREMENTS HAVE BEEN INCREASING OVER THE YEARS. EARLIER AIRCRAFT HAD DESIGN LIVES OF 4000 HOURS; THE F-18 IS DESIGNED TO 6000 FLIGHT HOURS. THE A-6 COMPOSITE WING HAS A DESIGN LIFE OF 8800 FLIGHT HOURS AND THE V-22 IS DESIGNED TO 10,000 HOURS. THESE INCREASED REQUIREMENTS HAVE PROVIDED ADDITIONAL INCENTIVES FOR THE USE OF ADVANCED COMPOSITES WHICH ARE ESSENTIALLY INSENSITIVE TO FATIGUE.

THE NAVY'S OPERATING ENVIRONMENT MAKES CORROSION CONTROL A HIGH COST MAINTENANCE ITEM. THE FACT THAT COMPOSITES DO NOT CORRODE IS THUS OF EXTREME IMPORTANCE TO THE NAVY.

THESE BENEFITS TAKEN TOGETHER RESULT IN INCREASED PERFORMANCE, LOWER LIFE CYCLE COSTS, AND INCREASED MISSION AVAILABILITY.



MAJOR BENEFITS TO NAVY



- REDUCED WEIGHT
- INCREASED FATIGUE LIFE
- CORROSION RESISTANCE

**INCREASED PERFORMANCE
AND AVAILABILITY**

THIS PAGE INTENTIONALLY BLANK



MAJOR BENEFITS TO NAVY

● REDUCED WEIGHT

- INCREASED FATIGUE LIFE
- CORROSION RESISTANCE

INCREASED PERFORMANCE
AND AVAILABILITY

AIRCRAFT WEIGHT SAVINGS

THIS CHART SHOWS WEIGHT SAVINGS FOR VARIOUS AIRCRAFT WHICH INCORPORATE ADVANCED COMPOSITE MATERIALS. THE PERCENT COMPOSITES BY WEIGHT HAS INCREASED OVER THE YEARS AS CONFIDENCE IN THEIR USE WAS OBTAINED.

CURRENTLY FLYING NAVY AIRCRAFT HAVE SHOWN SIGNIFICANT WEIGHT SAVINGS THROUGH THE USE OF ADVANCED COMPOSITES, THE MOST DRAMATIC OF WHICH IS THE V-22 WHICH SAVED 15% (ALMOST 2000 POUNDS) USING PRIMARILY GRAPHITE EPOXY.

IT IS INTERESTING TO NOTE THAT AS PART OF THE TRADE STUDIES LEADING TO THE FINAL V-22 DESIGN, A COMPARISON WAS MADE BETWEEN THE GRAPHITE/EPOXY WING TORQUE BOX AND AN EQUIVALENT ALUMINUM TORQUE BOX DESIGNED TO THE SAME CRITERIA. IT WAS FOUND THAT THE WEIGHT SAVINGS ACHIEVED THROUGH THE USE OF COMPOSITES WAS 591 POUNDS OR 28% OF THE WEIGHT OF THE METAL TORQUE BOX. THE SAME MATERIALS USED IN THE WING ARE ALSO USED FOR THE FUSELAGE AND EMPENNAGE OF THE V-22.

THE WEIGHT SAVINGS SHOWN FOR THE A-6 WING REQUIRES SOME EXPLANATION.

THE A-6 DESIGN REWING REQUIREMENTS WERE:

- 8000 FLIGHT HOURS INSTEAD OF 6000 FLIGHT HOURS
- 20% INCREASE IN LOADS OVER THE ORIGINAL DESIGN LOADS

THESE INCREASES WERE TO BE ACCOMPANIED BY NO INCREASE IN WING STRUCTURAL WEIGHT. THE 700 POUND WEIGHT SAVINGS SHOWN IS THE WEIGHT SAVED OVER A METAL DESIGN CAPABLE OF TAKING THE SAME LOADS AS THE COMPOSITE.



AIRCRAFT WEIGHT SAVINGS



AIRCRAFT T/M/S	AIRFRAME WEIGHT	% COMPOSITES (BY WEIGHT)	% WEIGHT SAVED	LBS WEIGHT SAVED
F-18	11360	10	5	565
AV-8B	5262	26	10	525
A-6 (WING)	4936	38	14	700
V-22 (WITH ROTOR)	13007	51	15	1962



MAJOR BENEFITS TO NAVY

- **REDUCED WEIGHT**
- **INCREASED FATIGUE LIFE**
- **CORROSION RESISTANCE**

**INCREASED PERFORMANCE
AND AVAILABILITY**

METAL FATIGUE PROBLEMS

THIS SKETCH DEPICTS TYPICAL PROBLEMS ENCOUNTERED WITH METAL STRUCTURE DURING THE FATIGUE TEST OR IN AIRCRAFT SERVICE. IN THE CASE OF THIS ALUMINUM BULKHEAD IN WHICH HIGH LOADS ARE INTRODUCED AT WING AND LANDING GEAR ATTACHMENTS, THE CRACKS OCCURRED DURING THE FULL SCALE FATIGUE TEST. THE CRACKS INITIATED AT HIGH STRESS AREAS DUE TO LOCAL RADII STRESS CONCENTRATIONS. FIXES WERE DEVELOPED AND THE FATIGUE TEST PROGRAM WAS CONTINUED. IN SOME INSTANCES, THESE FATIGUE PROBLEMS ARE NOT DETECTED UNTIL A NUMBER OF AIRCRAFT HAVE ALREADY BEEN DELIVERED TO THE FLEET, AND REWORK, WHICH CAN BE EXTREMELY COSTLY FOR INTERNAL STRUCTURE, IS NECESSARY FOR ALL AIRCRAFT OF THIS TYPE.



METAL FATIGUE PROBLEMS

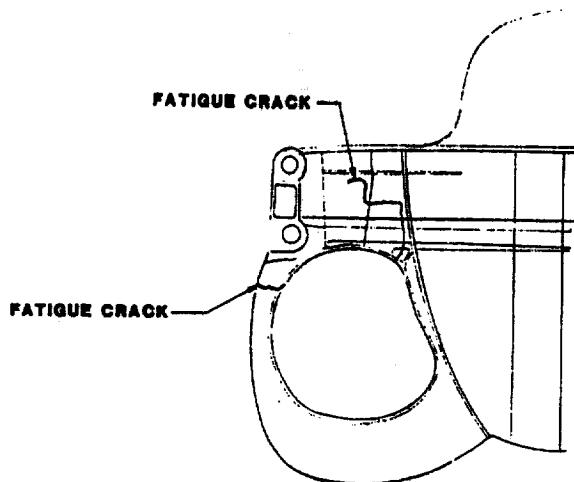

PHOTOGRAPH OF F-18 COMPOSITE BULKHEAD

THE NAVAL AIR DEVELOPMENT CENTER AND MCDONNELL AIRCRAFT COMPANY HAVE DESIGNED, FABRICATED AND TESTED A HIGHLY LOADED WING ATTACHMENT BULKHEAD WHICH DEMONSTRATES THE WEIGHT AND FATIGUE ADVANTAGES OF AN ALL COMPOSITE MAJOR LOAD CARRYING COMPONENT. THE BULKHEAD WAS DESIGNED TO MEET THE FORM AND FUNCTIONAL REQUIREMENTS OF THE F-18 FUSELAGE STATION 453 BULKHEAD. TWO ARTICLES WERE FABRICATED: THE FIRST BEING A MANUFACTURING DEMONSTRATION ARTICLE, AND THE SECOND INCORPORATING FABRICATION LESSONS LEARNED, A STRUCTURAL TEST ARTICLE.

FABRICATION OF THE SECOND FULL SCALE ARTICLE, USING IM7/8551-7A GRAPHITE/EPOXY PREPREG, AND TESTING OF THE CARRY-THROUGH BEAM PORTION VERIFIED THE PRODUCIBILITY, STRENGTH AND DURABILITY OF THE DESIGN THEREBY PRESENTING THE OPPORTUNITY FOR USE ON AIRCRAFT UPGRADES AND NEW AIRCRAFT. FOLLOWING TWO LIFETIMES OF ENHANCED, TO ACCOUNT FOR COMPOSITE SCATTER, F-18 WING FATIGUE LOADS THE BULKHEAD WAS SUCCESSFULLY LOADED TO FAILURE WHICH OCCURRED AT 186% DESIGN LIMIT LOAD. A 15% WEIGHT SAVINGS WAS ACHIEVED AND, MORE IMPORTANTLY, THE FATIGUE PROBLEMS THAT NORMALLY PLAGUE METAL BULKHEAD ARE VIRTUALLY ELIMINATED.





MAJOR BENEFITS TO NAVY



- **REDUCED WEIGHT**
- **INCREASED FATIGUE LIFE**

CORROSION RESISTANCE

**INCREASED PERFORMANCE
AND AVAILABILITY**



ENVIRONMENTAL DEGRADATION



- **CORROSION IS A SIGNIFICANT MAINTENANCE ISSUE**
- **CORROSION ACCOUNTS UP TO 15% OF THE MAINTENANCE MAN-HOURS**
- **COSTS RELATED TO CORROSION, 900 MILLION DOLLARS FOR NAVAL AIRCRAFT**
- **COMPOSITE MATERIALS REDUCE MAINTENANCE HOURS**

UNSCHEDULED MAINTENANCE EXPENDED ON CORROSION

CORROSION MAINTENANCE MANHOURS REFLECT A GENERAL DECREASING TREND DESPITE AN AGING FLEET DUE TO:

- IMPROVED CORROSION CONTROL PRODUCTS/PROCEDURES
 - UTILIZATION OF IMPROVED MATERIALS SERVING AS BARRIERS; I.E. COATINGS
 - IMPROVED METHODS OF ASSEMBLY
 - PROPER DESIGN CHOICES OF METALLIC MATERIALS
 - IMPROVED SURFACE TREATMENTS
- USE OF POLYMERIC COMPOSITES



UNSCHEDULED MAINTENANCE EXPENDED ON CORROSION



AIRCRAFT	TOTAL MAINTENANCE DMMH/YR THOUSANDS	CORROSION MAINTENANCE DMMH/YR THOUSANDS	% CORROSION MAINTENANCE
A-6	2,251	337	15
E-2	648	99	7.7
P-3	3,143	303	9.6
F-14	2,401	232	9.7
F-18	418	11	2.6

Includes only organizational and intermediate levels
 TDMMH Direct Maintenance Man-hours

DESIGN DRIVERS ARE INCREASING

EARLY APPLICATIONS OF COMPOSITES WERE CONCERNED PRIMARILY WITH REDUCING STRUCTURAL WEIGHT. THIS WAS THE MAJOR DRIVER FOR THE USE OF COMPOSITES IN THE F-14, F-18 AND AV-8B. IN THESE APPLICATIONS 15-20% WEIGHT SAVINGS WERE ACHIEVED.

RECENT AIRCRAFT PROGRAMS (V-22 & A-8 WING) HAVE INCLUDED DAMAGE TOLERANCE AND SURVIVABILITY REQUIREMENTS. DAMAGE TOLERANCE REQUIREMENTS DIRECTED AT LOW ENERGY IMPACT DAMAGE HAVE BEEN INCLUDED TO CONFORM WITH THE NAVY PHILOSOPHY OF NOT REQUIRING ROUTINE INSPECTIONS. THUS, SERVICE LIFE REQUIREMENTS MUST BE MET WITH THE MOST SEVERE NON-VISIBLE DAMAGE POSSIBLE. SPECIFIED SURVIVABILITY REQUIREMENTS FOR THESE AIRCRAFT WERE A SINGLE HIT BY A 23MM HEI PROJECTILE.

IN THE FUTURE, IT IS ANTICIPATED THAT IN ADDITION TO CURRENT DRIVERS, LOW OBSERVABILITY, QUALITY, COST AND SUPPORTABILITY WILL BE IMPORTANT. IN FACT, IN THE CURRENT CLIMATE OF BUDGET REDUCTIONS, COST CONSIDERATIONS MAY BE OF EQUAL IMPORTANCE TO WEIGHT.



DESIGN DRIVERS ARE INCREASING



PAST
(1970'S)

F-14
F-18
AV-8B

WEIGHT

PRESENT
(1980'S)

V-22
A-8

**WEIGHT
DAMAGE TOL.
SURVIVABILITY**

FUTURE
(1990'S)

INTERIM F/A
AX
?

**WEIGHT
DAMAGE TOL.
SURVIVABILITY
LOW OBSERV.
QUALITY
COST
SUPPORTABILITY**

INCREASING DEMANDS →

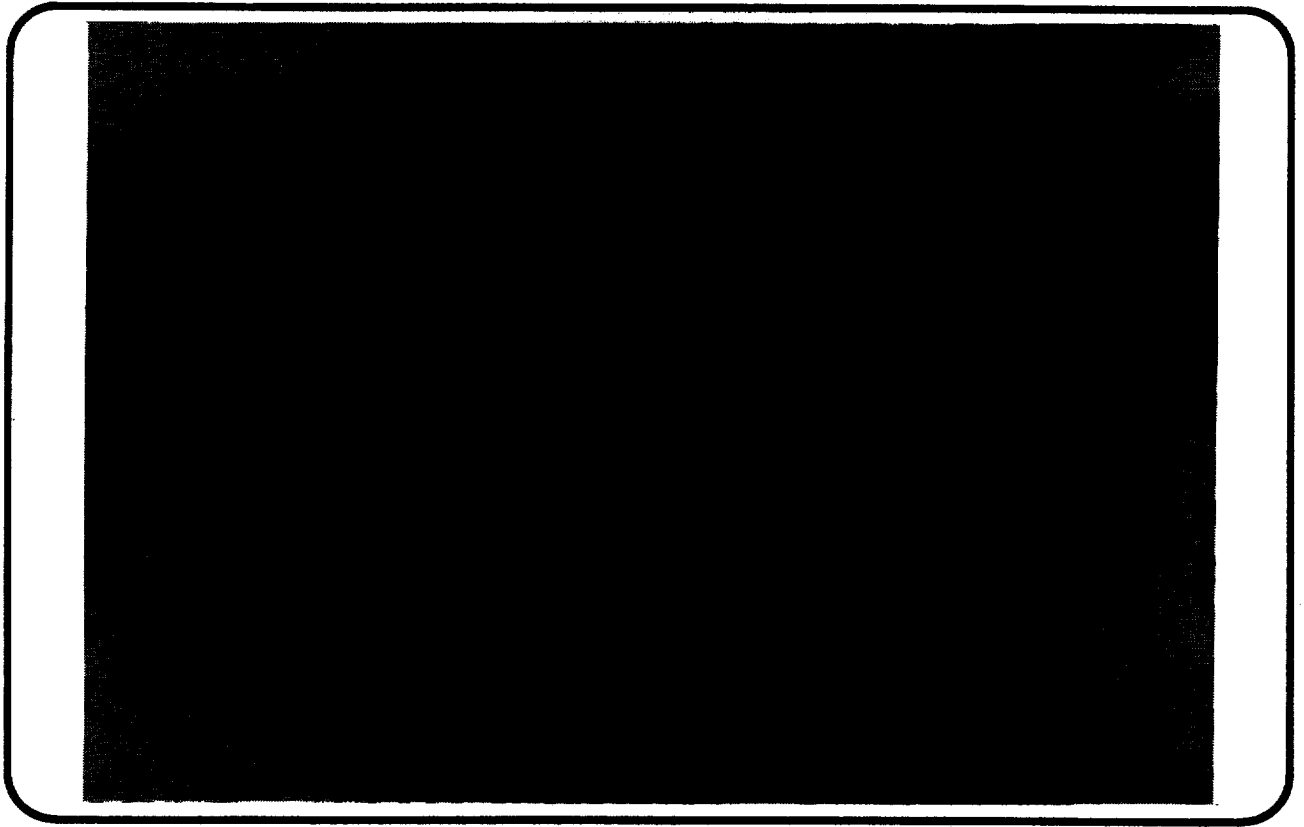

NAVY ASSESSMENT OF CURRENT COMPOSITE STRUCTURES

- **PERFORMANCE EXPECTATIONS GENERALLY MET**

TO DATE, COMPOSITE STRUCTURES EXPERIENCES HAVE BEEN FAVORABLE. IN SERVICE, NO MAJOR STATIC OR FATIGUE FAILURES HAVE OCCURRED. CURRENT FLIGHT TESTING OF THE V-22 HAS NOT REVEALED ANY STRUCTURAL PROBLEMS; HOWEVER, THIS TESTING IS STILL IN ITS EARLY STAGES AND THE FLIGHT ENVELOPE HAS NOT AS YET BEEN EXTENDED TO INCLUDE ALL CRITICAL DESIGN CONDITIONS.

- **DEVELOPMENT AND PRODUCTION COSTS HIGH**

BECAUSE OF THE LIMITED EXPERIENCE WITH COMPOSITE STRUCTURES WITHIN THE INDUSTRY, RELATIVE TO METALS, AN EXTENSIVE DEVELOPMENT PROGRAM PRIOR TO FULL SCALE TESTING IS CURRENTLY CONSIDERED A NECESSITY. THE COSTS ARE HIGH BUT ARE EXPECTED TO BE PART OF ANY NEW PROGRAM IN THE FORESEEABLE FUTURE. BASIC MATERIAL COSTS ARE HIGH AND CURRENT COMPOSITE MANUFACTURING AND INSPECTION PROCEDURES ARE EXTREMELY LABOR INTENSIVE RESULTING IN HIGH COSTS. THESE COSTS MUST BE REDUCED TO INSURE CONTINUED EXTENSIVE USE OF COMPOSITES IN FUTURE A/C SYSTEMS.

- **BASIC MANUFACTURING METHODS USED TO FABRICATE COMPOSITE PARTS HAVE PROGRESSED LITTLE IN THE PAST 20 YEARS.**

- **MANUFACTURING DISCREPANCIES SUCH AS DELAMINATIONS AND INCLUSIONS REMAIN A PROBLEM IN BOTH PART FABRICATION AND FINAL ASSEMBLY.**

- **NEW MATERIAL SYSTEMS ARE NEEDED WITH IMPROVED DAMAGE TOLERANCE AND STRENGTH AT CRITICAL ENVIRONMENTS TO BETTER MEET INCREASING DEMANDS OF FUTURE WEAPONS SYSTEMS.**

- **NO MAJOR PROBLEMS ATTRIBUTED TO THE USE OF COMPOSITES HAVE BEEN ENCOUNTERED IN SERVICE. ALTHOUGH DAMAGE TOLERANCE IS AN ON-GOING CONCERN, EXPERIENCES TO DATE HAVE SHOWN IT TO BE MORE OF A PROBLEM IN THE FACTORY THAN IN OPERATIONAL SERVICE.**

- **ALTHOUGH FACILITIES AND EQUIPMENT ABOARD THE CARRIER ARE LIMITED, COMPOSITES HAVE BEEN SHOWN TO BE SUPPORTABLE IN THIS ENVIRONMENT.**



NAVY ASSESSMENT OF CURRENT COMPOSITE STRUCTURES



- **PERFORMANCE EXPECTATIONS GENERALLY MET**
- **DEVELOPMENT AND PRODUCTION COSTS HIGH**
- **MANUFACTURING TECHNOLOGY LAGGING**
- **MANUFACTURING QUALITY CRITICAL ISSUE**
- **BETTER MATERIALS NEEDED**
- **SERVICE EXPERIENCE FAVORABLE**
- **SUPPORTABLE IN CARRIER ENVIRONMENT**



NAVY ASSESSMENT OF CURRENT COMPOSITE STRUCTURES



- **PERFORMANCE EXPECTATIONS GENERALLY MET**
- **DEVELOPMENT AND PRODUCTION COSTS HIGH**
- **MANUFACTURING TECHNOLOGY LAGGING**
- **MANUFACTURING QUALITY CRITICAL ISSUE**
- **BETTER MATERIALS NEEDED**
- **SERVICE EXPERIENCE FAVORABLE**
- **SUPPORTABLE IN CARRIER ENVIRONMENT**

PRODUCTION EXPERIENCE

THE NAVY PERIODICALLY CONDUCTS QUALITY AUDITS OF ON-GOING PRODUCTION CONTRACTS. THESE AUDITS, KNOWN AS PRODUCT ORIENTED SURVEYS (POS) HAVE UNCOVERED A NUMBER OF ISSUES RELATED TO MANUFACTURING AND QUALITY ASSURANCE OF COMPOSITE STRUCTURES. MAJOR ISSUES INCLUDE:

ENGINEERING FLOWDOWN - EARLY IN THE DEVELOPMENT PHASE, ENGINEERING IS INTIMATELY INVOLVED IN THE FABRICATION OF PARTS. AS PRODUCTION STARTS, ENGINEERING'S INVOLVEMENT TENDS TO DECREASE. ONCE PRODUCTION IS UNDERWAY, ENGINEERING SUPPORT IS PRACTICALLY NON-EXISTENT. THIS RESULTS, IN SOME CASES, IN CHANGES BEING MADE WITHOUT CONSULTING WITH DESIGN AND STRESS ENGINEERS WHICH MAY EFFECT THE STRUCTURAL INTEGRITY OF THE PART.

TRAINING - IN MANY CASES IT HAS BEEN OBVIOUS THAT TRAINING IN THE PROPER HANDLING AND FABRICATION OF COMPOSITE PARTS IS INADEQUATE. THIS RESULTS IN REDUCED OR UNACCEPTABLE QUALITY PARTS.

PROCESS VERIFICATION & CONTROL - IN MANY INSTANCES IT IS OBSERVED THAT THE CONTRACTOR IS NOT ADEQUATELY INCLUDING PROCESS VERIFICATION PANELS TO ACCOMPANY MAJOR PARTS DURING PROCESSING. THE INTENT OF THESE TRAVELER PANELS IS TO PERFORM DESTRUCTIVE TESTING TO VERIFY MATERIAL QUALITY AND PROCESSING.

FOREIGN MATERIAL INCLUSIONS AND DETECTION - A MAJOR PROBLEM DURING FABRICATION OF COMPOSITE PARTS REMAINS THE INCLUSION OF FOREIGN MATERIALS WITHIN THE LAMINATE. THIS PROBLEM EXISTS AT VIRTUALLY ALL FABRICATION FACILITIES AND RESULTS IN SCRAPPAGE OF MANY PARTS. ALTHOUGH ALL CONTRACTORS ARE AWARE OF THIS PROBLEM, AND EFFORTS ARE UNDERTAKEN TO ELIMINATE IT, IT STILL EXISTS. FURTHER, MANY OF THESE MATERIALS CANNOT BE DETECTED WITHOUT EXTENSIVE NON-DESTRUCTIVE INSPECTIONS.

MACHINING & DRILLING - IN MANY INSTANCES MACHINING AND DRILLING WERE NOT PERFORMED IN ACCORDANCE WITH COMPANY ISSUED SPECIFICATIONS RESULTING IN FIBER BREAKOUT AND DELAMINATIONS.

FIT-UP & ASSEMBLY - MAJOR FIT-UP PROBLEMS BETWEEN SKINS AND SUBSTRUCTURE REMAIN A CRITICAL PROBLEM. EXTENSIVE USES OF LIQUID SHIM ADD COSTS AND WEIGHT TO THE PRODUCT. FAILURE TO PROPERLY SHIM RESULTS IN DELAMINATIONS OCCURRING DURING FINAL ASSEMBLY.



PRODUCTION EXPERIENCE



MAJOR CONCERNS

- **ENGINEERING FLOWDOWN**

- **TRAINING**

- **PROCESS VERIFICATION AND CONTROL**

- **FOREIGN MATERIAL INCLUSIONS AND DETECTION**

- **MACHINING AND DRILLING**

- **FIT-UP**

- **ASSEMBLY**

MANUFACTURING

DEVELOPMENT OF IMPROVED MANUFACTURING PROCEDURES HAS ADVANCED VERY SLOWLY. BASICALLY, THE SAME TECHNIQUES USED TO FABRICATE THE AV-8B WING ARE STILL BEING USED.

IT IS TIME THAT MAJOR EFFORTS BE UNDERTAKEN TO REDUCE COSTS AND AT THE SAME TIME IMPROVE PART QUALITY. AUTOMATION IS THE OBVIOUS SOLUTION TO THIS PROBLEM. SOME METHODS CURRENTLY BEING EVALUATED INCLUDE TAPE LAYING MACHINES, FIBER PLACEMENT TECHNIQUES, WOVEN PREFORMS AND RESIN TRANSFER MOLDING.

NDI METHODS VARY GREATLY THROUGHOUT THE INDUSTRY. CURRENTLY NDI OF ALL PRIMARY COMPOSITE PARTS IS A NAVY REQUIREMENT. CONSISTENT NDI TECHNIQUES MUST BE ESTABLISHED THROUGHOUT THE INDUSTRY.

DUE TO INTERLAMINAR WEAKNESS OF COMPOSITES, ASSEMBLY METHODS THAT DO NOT ACCOUNT FOR POTENTIAL MISMATCHES RESULT IN OUT-OF-PLANE STRESSES WHICH CAUSE DELAMINATIONS. ASSEMBLY METHODS SHOULD ACCOUNT FOR GREATER TOLERANCES WHICH USUALLY OCCUR IN A PRODUCTION ENVIRONMENT.

AND FINALLY, CURRENT TOOLING TECHNIQUES FREQUENTLY RESULT IN INCREASED OUT-OF-TOLERANCE PARTS DURING PRODUCTION NECESSITATING FREQUENT TOOL REPLACEMENTS.



MANUFACTURING



- **COMPOSITES MANUFACTURING HAS ADVANCED VERY SLOWLY**
- **LARGE IMPROVEMENTS ARE NEEDED TO**
 - **REDUCE COST**
 - **IMPROVE QUALITY**
- **AUTOMATED LAY-UP METHODS WILL HELP**
- **QUALITY SYSTEMS MUST BE ESTABLISHED**
 - **INSPECTION**
 - **NDT**
 - **QUALITY CERTIFICATION**
- **ASSEMBLY METHODS NEED TO RECOGNIZE INTERLAMINAR WEAKNESS OF COMPOSITES**
- **TOOLING MATERIALS AND CONCEPTS NEED IMPROVEMENT**

THIS PAGE INTENTIONALLY BLANK



NAVY ASSESSMENT OF CURRENT COMPOSITE STRUCTURES

- PERFORMANCE EXPECTATIONS GENERALLY MET
- DEVELOPMENT AND PRODUCTION COSTS HIGH
- MANUFACTURING TECHNOLOGY LAGGING
- MANUFACTURING QUALITY CRITICAL ISSUE
- BETTER MATERIALS NEEDED
- SERVICE EXPERIENCE FAVORABLE
- SUPPORTABLE IN CARRIER ENVIRONMENT

... PAGE BLANK, NOT FILMED

PAGE 66 INTENTIONALLY BLANK

INCREASED EMPHASIS NEEDED ON MANUFACTURING QUALITY

COMPOSITES ARE HIGHLY SENSITIVE TO MANUFACTURING PROCESS VARIATIONS. IT MUST BE RECOGNIZED THAT WHAT MAY APPEAR TO BE A SMALL CHANGE IN A PROCESSING VARIABLE MAY RESULT IN A SIGNIFICANT CHANGE IN MATERIAL PROPERTIES. THEREFORE, A MANUFACTURING PLAN MUST BE DEVELOPED WHICH RECOGNIZES ANY UNIQUE PROCESSING REQUIREMENTS. THIS PLAN MUST BE AMENABLE TO THE ACTUAL PRODUCTION ENVIRONMENT AND MUST BE VERIFIED DURING FULL SCALE DEVELOPMENT, PRIOR TO PRODUCTION, WITH SUFFICIENT TIME ALLOTTED TO MAKE NECESSARY CHANGES WITHOUT IMPACT TO FULL SCALE TEST AND FLIGHT ARTICLES.

DURING THE SELECTION OF MATERIAL SYSTEMS, QUALITY MUST BE A PRIME CONSIDERATION. SUFFICIENT TIME AND RESOURCES MUST BE ALLOCATED FOR MATERIAL VERIFICATION AND THE DEVELOPMENT OF MANUFACTURING PROCESSES.

DESIGNS ARE USUALLY GENERATED ASSUMING SUPERIOR MANUFACTURING CAPABILITIES FOUND IN THE DEVELOPMENT PHASE OF THE PROGRAM RATHER THAN THOSE EXISTING IN THE PRODUCTION ENVIRONMENT. AS A RESULT, QUALITY IS LESS THAN EXPECTED.

QUALITY SIGNIFICANTLY IMPACTS COST, SCHEDULE, PERFORMANCE AND READINESS/MAINTAINABILITY. IN THE PAST, QUALITY HAS DETERIORATED DURING THE TRANSITION FROM DEVELOPMENT TO PRODUCTION DUE TO USE OF IMPROPERLY TRAINED WORKERS, TOOLING AND PROCESS CHANGES, AND REDUCED ENGINEERING SUPPORT. DURING PRODUCTION, QUALITY FURTHER DETERIORATES DUE TO COST AND SCHEDULE PRESSURES, RELATIVELY LITTLE ENGINEERING ATTENTION AND ADDITIONAL USE OF UNSKILLED WORKERS.

IN ORDER TO INSURE MANUFACTURING QUALITY, A FORMAL METHODOLOGY TO CERTIFY THESE PROCESSES MUST BE DEVELOPED.



INCREASED EMPHASIS NEEDED ON MANUFACTURING QUALITY



- COMPOSITES SENSITIVITY TO MANUFACTURING PROCESS VARIATIONS MUST BE RECOGNIZED
- TIMELY MANUFACTURING DEVELOPMENT MANDATORY - MAY PRECEDE DESIGN
- DESIGN MUST BE MANUFACTURABLE IN PRODUCTION ENVIRONMENT
- INCREASED EFFORT REQUIRED FOR COMPOSITES SHOULD BE RECOGNIZED IN MATERIAL SELECTION, SCHEDULING, RESOURCE, ETC.
- METHODOLOGY TO FORMALLY CERTIFY THE MANUFACTURING/QUALITY PROCESSES NEEDS TO BE DEVELOPED



NAVY ASSESSMENT OF CURRENT COMPOSITE STRUCTURES



- PERFORMANCE EXPECTATIONS GENERALLY MET
- DEVELOPMENT AND PRODUCTION COSTS HIGH
- MANUFACTURING TECHNOLOGY LAGGING
- MANUFACTURING QUALITY CRITICAL ISSUE
- BETTER MATERIALS NEEDED
- SERVICE EXPERIENCE FAVORABLE
- SUPPORTABLE IN CARRIER ENVIRONMENT

MATERIAL IMPROVEMENTS

- **PROPERTIES**
 - FURTHER GAINS IN PERFORMANCE ARE MATERIALS LIMITED
 - HIGHER SPECIFIC STRENGTH AND STIFFNESS
 - IMPROVED COMPRESSION STRENGTH
- **VARIABILITY**
 - REDUCED BATCH TO BATCH VARIATIONS
 - PRE-PREG RESIN CONTENT VARIATIONS
- **PROCESSABILITY**
 - BATCH VARIABILITY, OUT TIME, COMPONENT COMPLEXITY CONTRIBUTES TO PROCESS PROBLEMS
 - KEY TO REPRODUCIBILITY
- **COST**
 - COST OF BASIC MATERIALS (FIBER, RESIN, PREPREG) MUST BE REDUCED
- **SPECIFICATIONS**
 - STANDARD MATERIAL AND PERFORMANCE SPECIFICATIONS WILL IMPROVE REPRODUCIBILITY AND REDUCE COST
- **MATERIAL FORMS**
 - MULTIPLE MATERIAL FORMS IN CONJUNCTION WITH NOVEL PROCESSES OFFER POTENTIAL COST SAVINGS
 - QUALIFICATION OF MULTIPLE FORMS MUST BE ADDRESSED
- **TOUGHER RESINS**
 - DAMAGE TOLERANCE RELIES ON RESIN TOUGHNESS
 - IMPROVEMENTS TRANSLATE INTO STRUCTURAL EFFICIENCY
- **ENVIRONMENTAL RESISTANCE**
 - NAVY HAS AN EXTREMELY AGGRESSIVE ENVIRONMENT
 - MATERIALS MUST PERFORM UNDER EXPOSURE TO HEAT, MOISTURE, SOLVENTS, GALVANIC EFFECTS



MATERIAL IMPROVEMENTS NEEDED



- **PROPERTIES**
- **VARIABILITY**
- **PROCESSABILITY**
- **COST**
- **TOUGHER RESINS**
- **ENVIRONMENTAL RESISTANCE**
- **SPECIFICATIONS**
- **MATERIAL FORMS**



NAVY ASSESSMENT OF CURRENT COMPOSITE STRUCTURES



- PERFORMANCE EXPECTATIONS GENERALLY MET
- DEVELOPMENT AND PRODUCTION COSTS HIGH
- MANUFACTURING TECHNOLOGY LAGGING
- MANUFACTURING QUALITY CRITICAL ISSUE
- BETTER MATERIALS NEEDED
- SERVICE EXPERIENCE FAVORABLE
- SUPPORTABLE IN CARRIER ENVIRONMENT

SERVICE EXPERIENCE

RECURRING DAMAGE AND CAUSES:

- **PUNCTURE OF THIN-SKIN HONEYCOMB STRUCTURE**
 - DROPPED TOOLS/PARTS
 - YELLOW GEAR IMPACT
- **DELAMINATIONS AND DISBONDS**
 - DROPPED TOOLS/IMPACT DAMAGE
- **EDGE CRUSHING**
 - YELLOW GEAR IMPACT
 - AIRCRAFT TO AIRCRAFT CONTACT IN LIMITED CARRIER SPACE
- **HOLE WEAR/DELAMINATION**
 - DUE MAINLY TO REPEATED REMOVAL OF DOORS AND ACCESS PANELS
- **HEAT DAMAGE**
 - AV-8B STRUCTURE EXPOSED TO HOT NOZZLE EXPOSURE. (A DAMAGED STRAKE IS SHOWN IN THE NEXT VIEWGRAPH)
 - CLOSE ENCOUNTER WITH OTHER AIRCRAFT EXHAUST, USUALLY ABOARD THE CARRIERS
 - IN THE CASE OF THE AV-8B, SOME HEAT DAMAGE HAS OCCURRED BECAUSE PILOTS TAXI WITH THEIR FLAPS DOWN WHICH IS AGAINST PROCEDURE AND THE NOZZLE EXHAUST OVERHEATS THE FLAPS.
- **CHAFING**
 - CAUSED BY RUBBING OF MOVABLE PARTS AGAINST ADJACENT STRUCTURE BECAUSE OF OUT-OF TOLERANCE DIMENSIONS
- **OTHER DAMAGE**
 - HAIL DAMAGE - A FEW INCIDENTS HAVE BEEN REPORTED, WITH THE AIRCRAFT HAVING BEEN REPAIRED AND RETURNED TO SERVICE.
 - BIRD STRIKES - SOME INCIDENTS ON AV-8B NOSE CONE, FORWARD FUSELAGE, WINDSHIELD, AND LEADING EDGES
 - CRASH DAMAGE:
 - SEVERAL CRASHED AV-8B'S HAVE BEEN REPAIRED AND RETURNED TO SERVICE
 - V-22 NUMBER 5 CRASHED AND EVEN THOUGH THE DECISION HAS BEEN MADE TO SCRAP IT, THE CRASH WAS SURVIVABLE.

TOM DONNELAN WILL PRESENT A PAPER TUESDAY AFTERNOON ON "NAVY COMPOSITE MAINTENANCE AND REPAIR EXPERIENCE" WHICH WILL GIVE A MORE COMPREHENSIVE SUMMARY OF SERVICE EXPERIENCE.



SERVICE DAMAGE EXPERIENCE



- **FEW RECURRING PROBLEMS ENCOUNTERED**
 - PUNCTURE OF THIN-SKIN HONEYCOMB STRUCTURE
 - DELAMINATIONS AND DISBONDS
 - EDGE CRUSHING
 - HOLE WEAR/DELAMINATION
 - HEAT DAMAGE
 - CHAFING
- **OTHER DAMAGE**
 - HAIL DAMAGE
 - BIRD STRIKES
 - LANDING ZONE DEBRIS
 - CRASH DAMAGE

PHOTO OF HEAT DAMAGED AV-8B STRAKE

THE GUN-PAK STRAKE SHOWN IN THE PHOTO WAS DAMAGED BY REPEATED EXPOSURE TO HEAT FROM THE ENGINE EXHAUST NOZZLES IN THE VERTICAL TAKEOFF AND LANDING MODE. ONLY THE MOST AFT PORTION OF THESE STRAKES HAS EXPERIENCED HEAT DAMAGE.

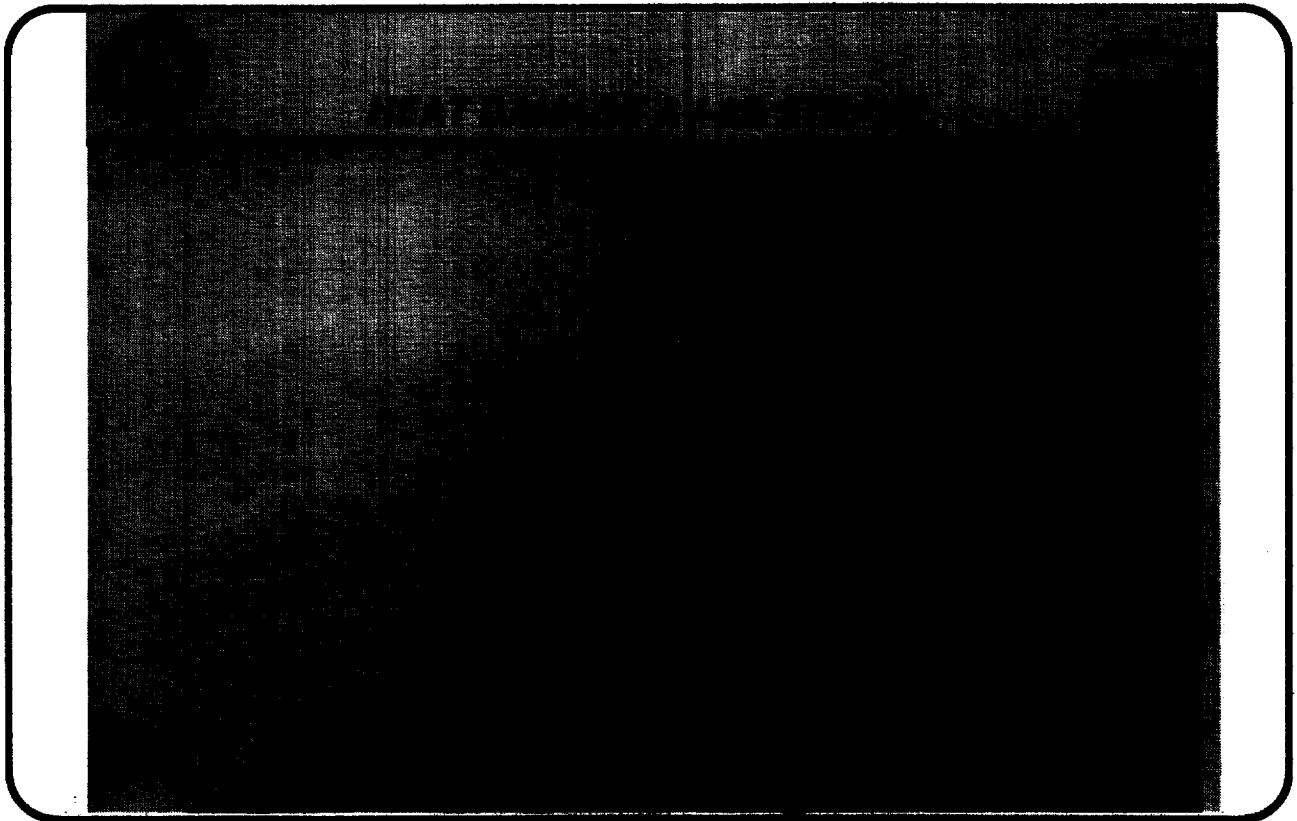
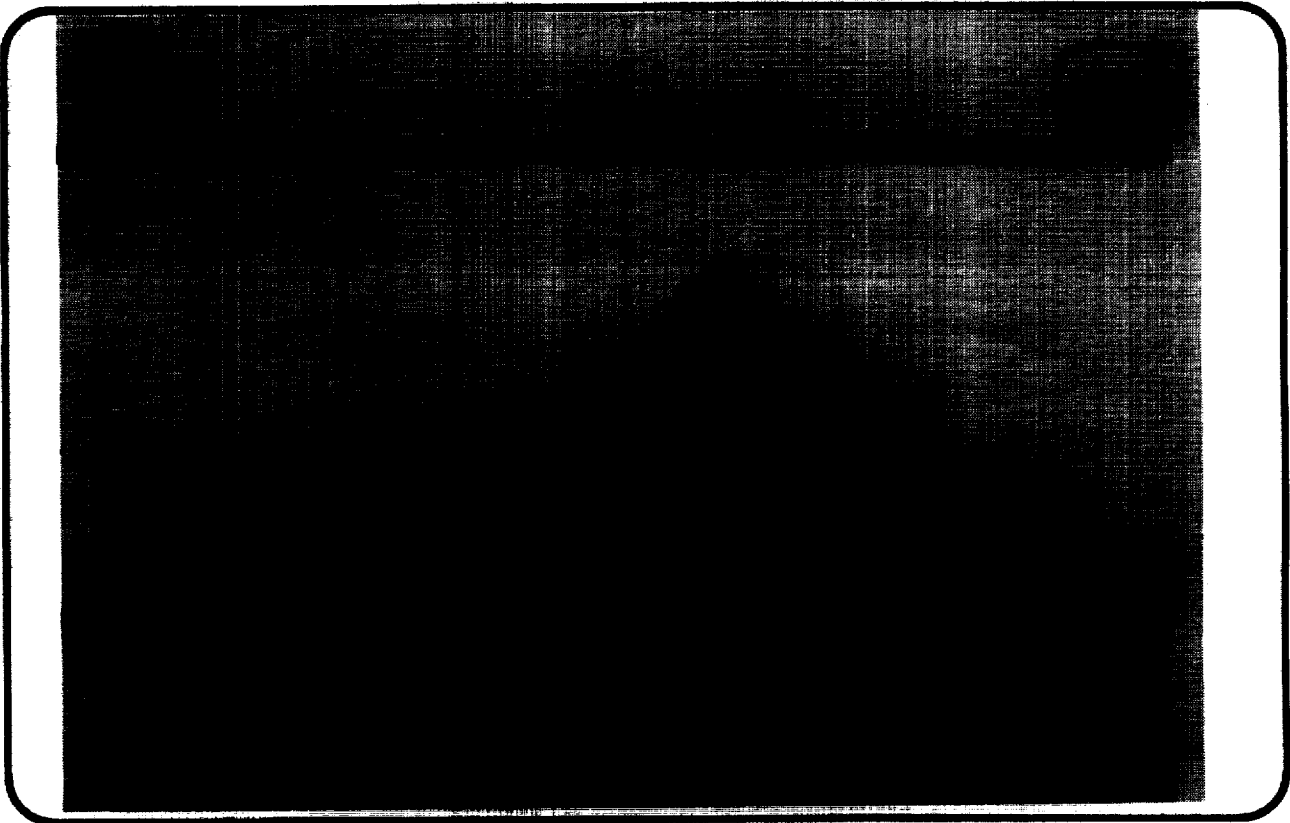

PHOTO OF HAIL DAMAGE

THE NEXT TWO PHOTOS SHOW AN AV-8B THAT WAS DAMAGED IN A HAIL STORM. THE AIRCRAFT WAS FLYING IN FORMATION WITH AN A-4 WHEN THEY INADVERTENTLY FLEW INTO A HAIL STORM. THE AV-8B SUFFERED EXTENSIVE DAMAGE TO ALL LEADING EDGE SURFACES IN ADDITION TO LOSING ITS CANOPY. NOTE THE WINDSCREEN WHICH WAS DESIGNED FOR BIRDSTRIKE IMPACT REMAINED INTACT. ALSO NOTE THE DIFFERENCES IN THE TYPES OF DAMAGE BETWEEN COMPOSITES AND METALS. THE FORWARD FUSELAGE AND NOSE CONE EXCEPT FOR THE METAL TIP ARE CARBON/EPOXY WHILE THE ENGINE INLETS AND WING AND STABILIZER LEADING EDGES ARE ALUMINUM. THE CARBON/EPOXY WING COVERS REMAINED UNDAMAGED.

BOTH AIRCRAFT RETURNED TO BASE SAFELY. AFTER REPLACING THE LIMITED NUMBER OF DAMAGED COMPONENTS, THE AV-8B WAS RETURNED TO SERVICE WHILE THE A-4 WAS SO BADLY DAMAGED THAT IT WAS SCRAPPED.



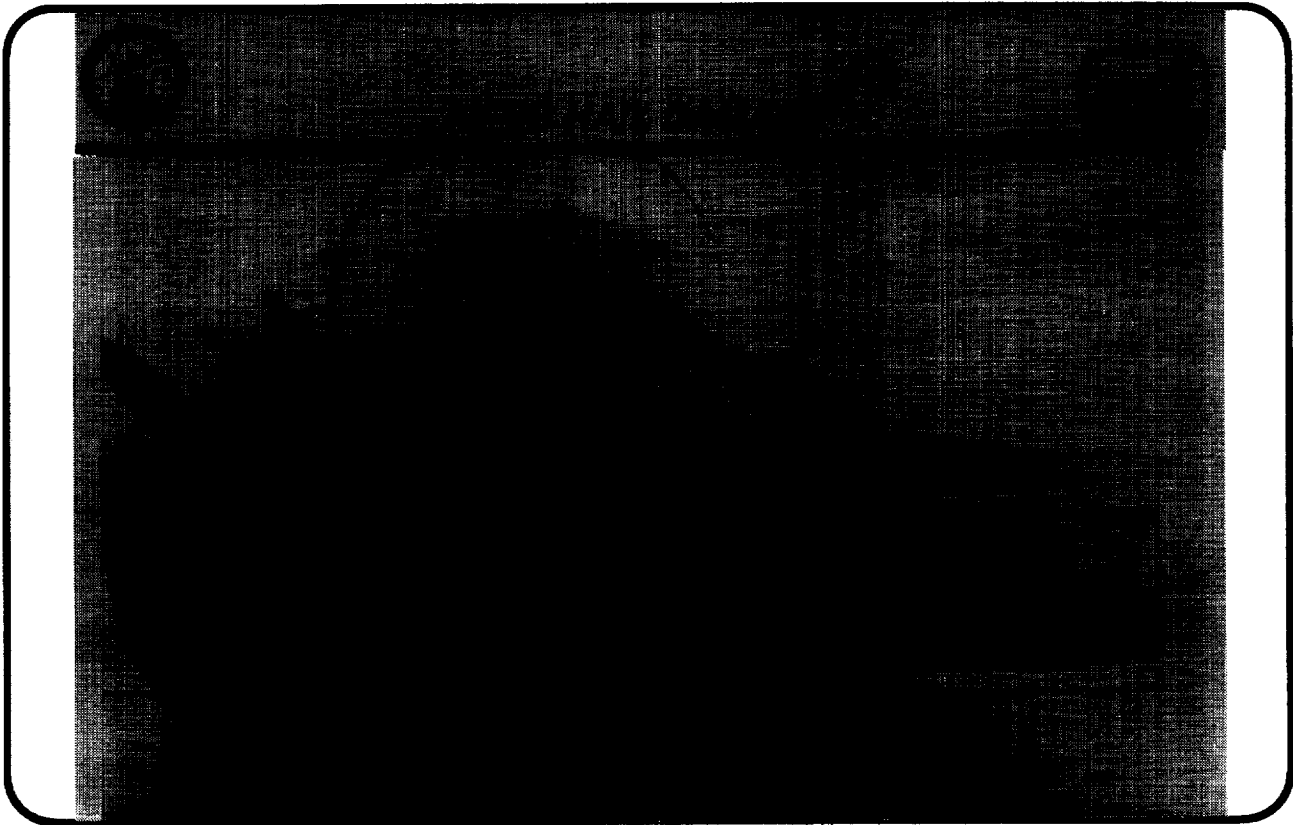
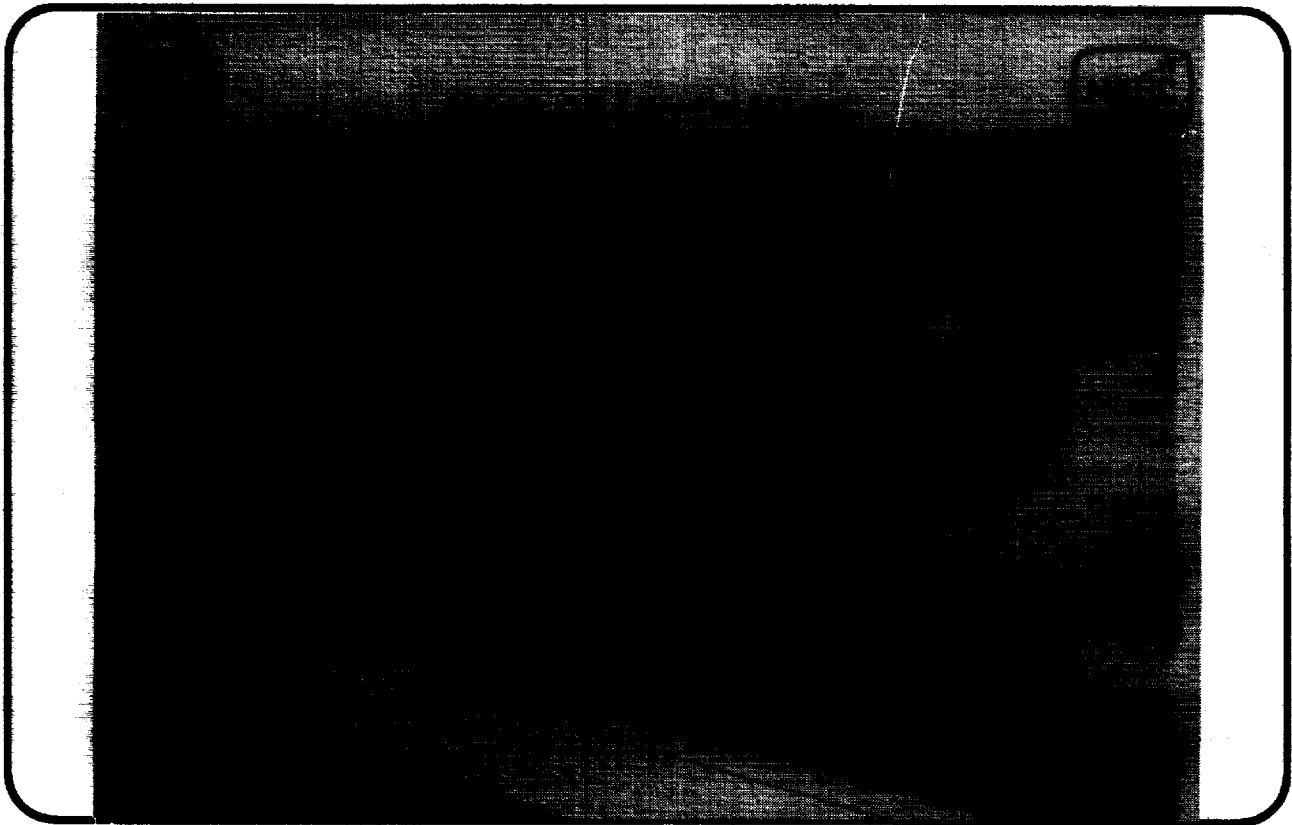

PHOTO OF CRASH DAMAGED TAV-8B STRAKE

THE AIRCRAFT INVOLVED TAXIED AT NIGHT INTO A CONCRETE HIGHWAY BARRIER BEING USED TO BLOCK A CLOSED RUNWAY. THE STRAKE IN THE PHOTO WAS SEVERELY DAMAGED, BUT ACCORDING TO STRUCTURAL ENGINEERS FROM NADEP, CHERRY POINT, THE DAMAGE TO THE STRAKE AND FUSELAGE ATTACHMENT WOULD HAVE BEEN MUCH WORSE IF THE STRAKE HAD BEEN MADE OF ALUMINUM. THE STRAKE WAS REPAIRABLE, BUT IT WAS MORE COST EFFECTIVE IN THIS CASE TO REPLACE IT.



PHOTOS OF AV-8B CRASH DAMAGE REPAIR

THE AIRCRAFT INVOLVED EXPERIENCED A NOSE WHEEL STEERING MALFUNCTION AND DEPARTED THE RUNWAY AT A HIGH RATE OF SPEED. AFTER THE PILOT EJECTED, THE AIRCRAFT CRASHED INTO A DITCH, SEVERELY DAMAGING THE NOSE SECTION AND WING TIP. IN THE PHOTO, A CRACK CAN BE SEEN THAT EXTENDS THROUGH THE CANOPY RAIL, DOWN THE SIDE OF THE COCKPIT, AND EVENTUALLY THROUGH THE LONGERONS. NO DAMAGE EXTENDED AFT OF THE CRACK. IN THE OPINION OF THE ENGINEERS FROM THE NADEP AT CHERRY POINT, A METAL AIRCRAFT WOULD HAVE BEEN MORE EXTENSIVELY DAMAGED SINCE THE METAL STRUCTURE WOULD HAVE "TELEGRAPHED" THE DAMAGE FURTHER AFT. THE WING TIP SUFFERED DAMAGE TO ITS UPPER AND LOWER SKINS AND THE OUTBOARD PYLON FITTING AND TIP RIB. NADEP CHERRY POINT WAS ABLE TO REPAIR THE AIRCRAFT BY INSTALLING A NEW FORWARD FUSELAGE SECTION OBTAINED FROM MCAIR. REPAIRS WERE ALSO REQUIRED ON THE WING TIP. THE REPAIR SHOWN IN THE NEXT PHOTO OF THE WING IS FROM A DIFFERENT AIRCRAFT BUT IS SIMILAR TO THE DAMAGE SUFFERED BY THIS AIRCRAFT. THE OUTBOARD PYLON FITTING AND TIP RIB WERE REPLACED AND A NEW OUTBOARD SKIN WAS SPLICED INTO THE EXISTING COVER SKIN. THE REPAIR TO THE SKIN SHOWS UP AS THE BLACK SECTION AT THE OUTBOARD END OF THE WING TIP.

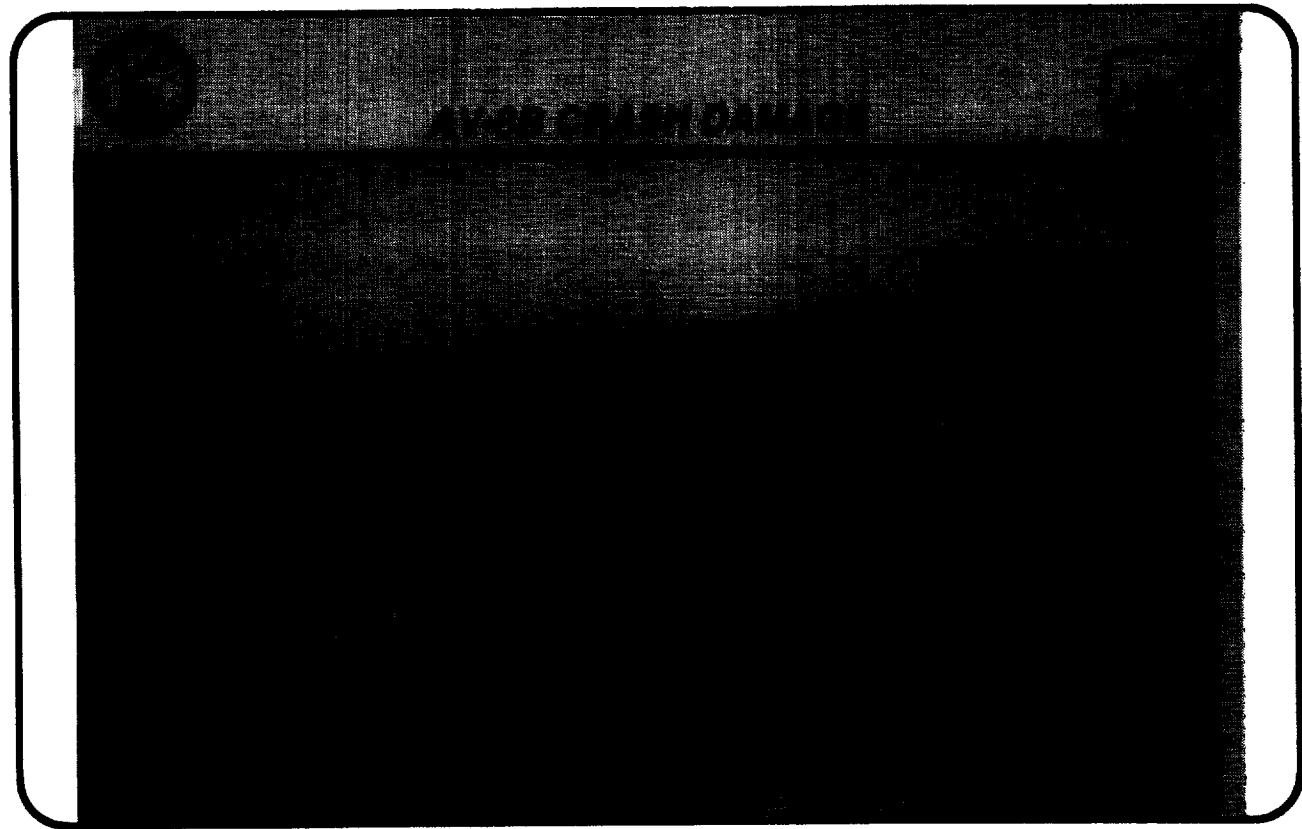
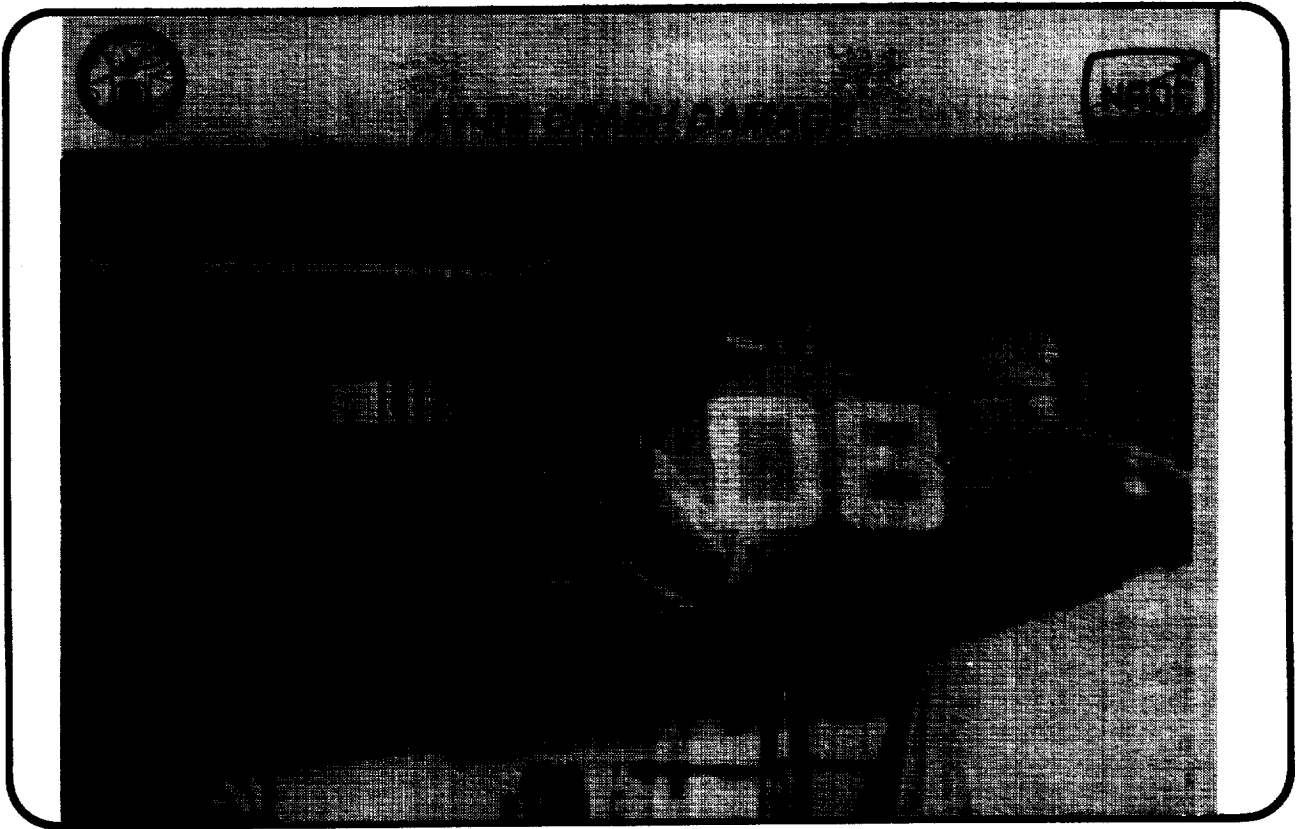

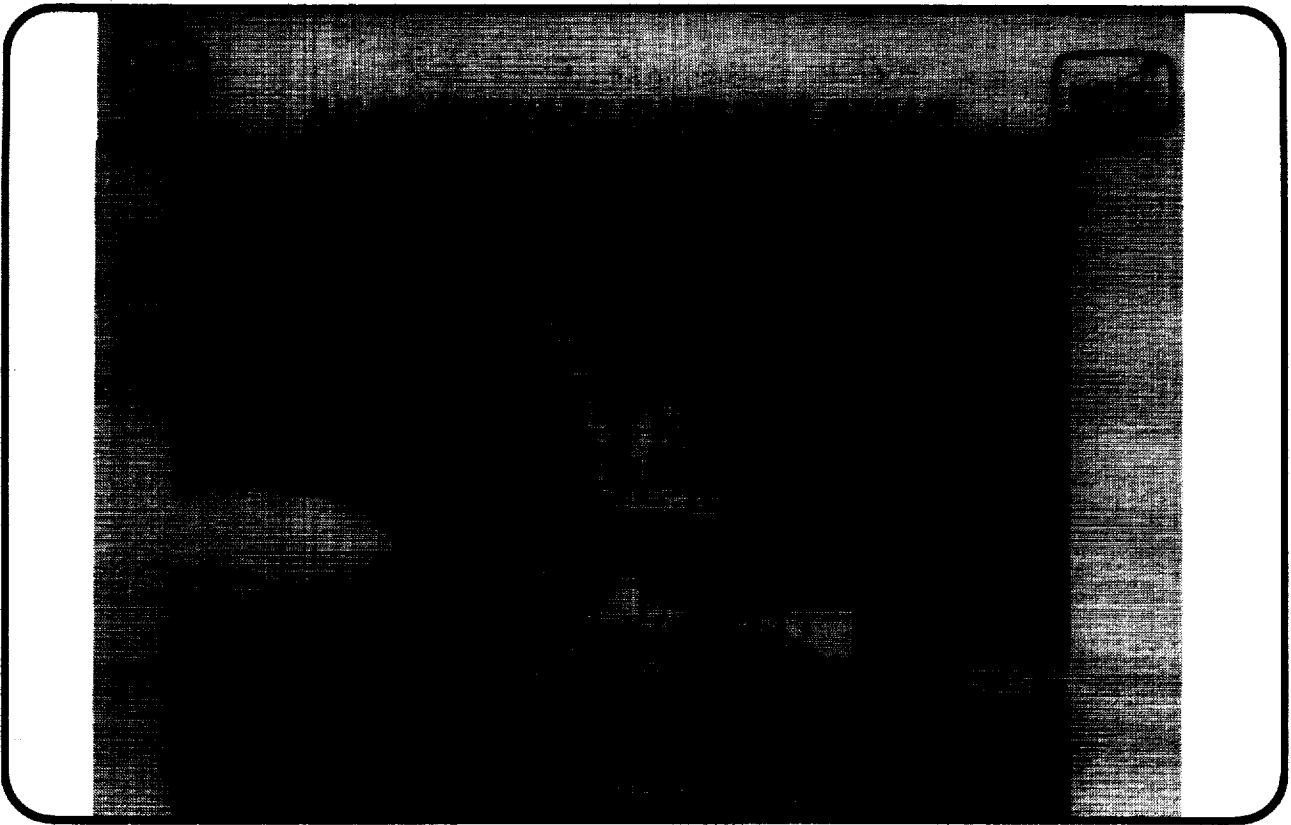

SERVICE RELATED CONCERNS

- **COMPOSITE INDUCED CORROSION**
 - **BREAKDOWN IN PROTECTIVE SCHEMES**

COMPOSITES CAN INDUCE CORROSION OF METALS
GRAPHITE BASED COMPOSITES CAUSE GALVANIC CORROSION IN SOME AIRCRAFT ALLOYS
PROTECTION SCHEMES DEVELOPED WHICH REDUCE THE PROBLEM
BREAKDOWN IN PROTECTION SCHEMES RESULT IN CORROSION OF THE METAL
IMIDE BASED COMPOSITES REQUIRE STRICT ATTENTION TO GALVANIC CORROSION SINCE COMPOSITES DEGRADE AS CORROSION OCCURS
- **SHELF-LIFE OF COMPOSITE MATERIALS FOR SHIPBOARD REPAIR**

REFRIGERATED STORAGE ON SHIPS EITHER DOES NOT EXIST OR CANNOT BE COUNTED ON. MOST MATERIALS HAVE LIMITED SHELF LIVES OF ABOUT 1 YEAR. REPAIR MATERIALS WITH SHELF LIVES OF AT LEAST 2 YEARS ARE NEEDED. NADC HAS DEVELOPED INNOVATIVE COMPOSITE REPAIR TECHNIQUES WHICH HAVE DEMONSTRATED THE SHELF LIFE OF MATERIALS TO OVER 18 MONTHS AT AMBIENT CONDITIONS AND ARE EXPECTED TO BE QUALIFIED FOR AT LEAST 2 YEARS SHORTLY.
- **LIGHTNING/EMI PROTECTION SCHEMES INDUCE PENALTIES**

TYPICAL PROTECTION SCHEMES USING FLAME SPRAY OR EXPANDED COPPER FOIL TO PROVIDE LIGHTNING/EMI PROTECTION ADDS NOT ONLY TO THE WEIGHT AND COST OF THE STRUCTURE, BUT ALSO INCREASES THE SUPPORTABILITY PROBLEMS. BETTER PROTECTION SCHEMES NEED TO BE DEVELOPED.
- **MAINTENANCE PROBLEMS ASSOCIATED WITH HONEYCOMB CONSTRUCTION**

WATER INTRUSION HAS LONG BEEN A PROBLEM WITH HONEYCOMB STRUCTURES. IN METAL HONEYCOMB IT CAUSES CORROSION, WHILE IN BOTH METAL AND NON-METALLIC HONEYCOMB, IT ADDS WEIGHT AND COMPLICATES THE REPAIR PROCEDURES SINCE THE STRUCTURE MUST BE DRIED BEFORE APPLYING HEAT.



SERVICE RELATED CONCERNS



- **COMPOSITE INDUCED CORROSION**
 - **BREAKDOWN IN PROTECTION SCHEMES**
- **SHELF-LIFE OF COMPOSITE MATERIALS FOR SHIPBOARD REPAIR**
- **LIGHTNING/EMI PROTECTION SCHEMES INDUCE PENALTIES**
- **MAINTENANCE PROBLEMS ASSOCIATED WITH HONEYCOMB CONSTRUCTION**

THIS PAGE INTENTIONALLY BLANK



NAVY ASSESSMENT OF CURRENT COMPOSITE STRUCTURES



- PERFORMANCE EXPECTATIONS GENERALLY MET
- DEVELOPMENT AND PRODUCTION COSTS HIGH
- MANUFACTURING TECHNOLOGY LAGGING
- MANUFACTURING QUALITY CRITICAL ISSUE
- BETTER MATERIALS NEEDED
- SERVICE EXPERIENCE FAVORABLE

• SUPPORTABLE IN CARRIER ENVIRONMENT

RECORDING PAGE BLANK, NOT FILMED

REPAIRABILITY

- **METHODS IN PLACE FOR SHIPBOARD REPAIR**

DUE TO THE LIMITED SHIPBOARD SPACE AVAILABLE, REPAIR PROCEDURES HAVE BEEN DEVELOPED THAT MINIMIZE THE NUMBER OF UNIQUE TOOLS, EQUIPMENT AND MATERIALS. THE LACK OF AUTOCLAVES, OVENS AND REFRIGERATED STORAGE HAS DRIVEN THE DEVELOPMENT OF VARIOUS INNOVATIVE COMPOSITE REPAIR TECHNIQUES WHICH HAS EXTENDED THE SHELF LIFE OF MATERIALS TO OVER 18 MONTHS AT AMBIENT CONDITIONS AND PRODUCED HIGH QUALITY REPAIRS.

- **REPAIR OPTIONS AVAILABLE**

BOTH BOLTED AND BONDED REPAIR TECHNIQUES EXIST TODAY FOR THE REPAIR OF DAMAGED COMPOSITE STRUCTURES. BONDED PROCEDURES HAVE BEEN DEVELOPED FOR BOTH EXTERNAL PATCHES AND FLUSH REPAIRS. MATERIALS/PROCESSES INCLUDE WET LAYUP, PRECURED AND STAGED FORMS.

BOLTED METHODS ARE SIMILAR TO METAL WORKING TECHNIQUES AND CAN UTILIZE ALUMINUM, STEEL OR TITANIUM DEPENDING ON THE PREDICTED LOADS AND FATIGUE REQUIREMENTS.

- **SIMPLICITY/REPAIR TIME COMPARABLE TO METAL REPAIRS**

THE SKILL LEVEL AND TIME REQUIRED FOR COMPOSITE REPAIRS ARE SIMILAR TO THOSE REQUIRED FOR METAL.

THE NEXT TWO PROGRAMS ARE DESCRIBED IN A LITTLE MORE DETAIL IN THE FOLLOWING VU-GRAPHS.

- **MAJOR PROGRAM IN PROGRESS ON THE V-22**

THE V-22 COMPOSITE REPAIR DEVELOPMENT (VCRD) (PRONOUNCED VEE-CARD) PROGRAM IS CURRENTLY ADDRESSING THE DESIGN OF REPAIRS TO PREDICTED DAMAGE IN 24 AREAS OF THE AIRCRAFT.

- **AIRCRAFT BATTLE DAMAGE REPAIR (ABDR) UNDER DEVELOPMENT**

THE PURPOSE OF ABDR IS TO RETURN BATTLE DAMAGED AIRCRAFT TO THE BATTLE AS SOON AS POSSIBLE SO THAT THEY MAY HAVE AN EFFECT ON THE OUTCOME OF THE BATTLE. WITH THIS IN MIND, DESIGN AND ANALYSIS TECHNIQUES ARE BEING DEVELOPED THAT WILL USE PERSONAL COMPUTERS TO ANALYZE LARGE SIZE DAMAGE TO COMPOSITE WING STRUCTURE.

- **METHODS NEEDED FOR LOW OBSERVABLE STRUCTURE**

LOW OBSERVABLE STRUCTURES IMPOSE ADDITIONAL REQUIREMENTS. SPECIAL DESIGN AND REPAIR PROCEDURES HAVE TO BE DEVELOPED WHICH DO NOT DEGRADE THE RCS SIGNATURE OF THE AIRCRAFT. WE HAVE JUST RECENTLY INITIATED WORK ON L.O. REPAIRS.



REPAIRABILITY



- **METHODS IN PLACE FOR SHIPBOARD REPAIR**
 - **REPAIR OPTIONS AVAILABLE**
 - **SIMPLICITY/REPAIR TIME COMPARABLE TO METAL**
- **MAJOR PROGRAM IN PROGRESS ON V-22**
- **AIRCRAFT BATTLE DAMAGE REPAIR UNDER DEVELOPMENT**
- **METHODS NEEDED FOR LOW OBSERVABLE STRUCTURE**

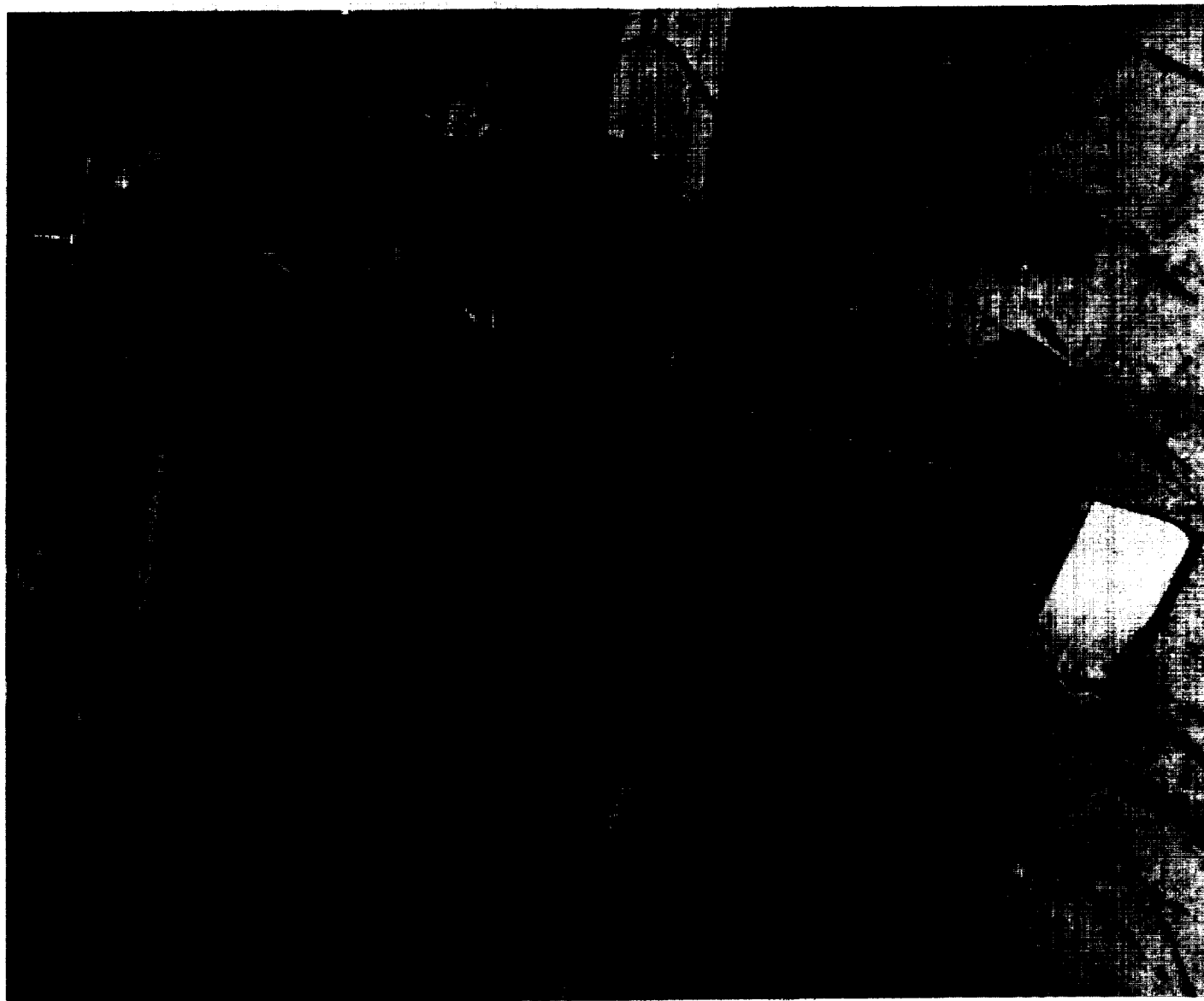

AV-8B

S T A B I L A T O R R E P A I R

THE V-22 COMPOSITE REPAIR DEVELOPMENT PROGRAM

IN THE PAST, LIMITED ATTENTION HAS BEEN PLACED ON COMPOSITE SUPPORTABILITY FOR NEW AIRCRAFT ACQUISITION PROGRAMS. AS A RESULT, LOGISTIC SUPPORT DIFFICULTIES, SUCH AS A LACK OF REPAIR METHODS AND REFRIGERATED MATERIALS HANDLING AND STORAGE, HAVE BEEN EXPERIENCED WHEN INITIALLY FIELDING COMPOSITE STRUCTURES IN THE SERVICE ENVIRONMENT. IN A DEPARTURE FROM PAST EXPERIENCE AND CONCERNED WITH THESE DIFFICULTIES, BOTH THE NAVY AND AIR FORCE LOGISTIC COMMUNITIES JOINTLY INITIATED THE V-22 COMPOSITE REPAIR DEVELOPMENT PROGRAM (VCRD) IN 1989. THE OBJECTIVE OF THIS PROGRAM HAS BEEN TO DEVELOP AND VALIDATE, BY FLEET EVALUATION AND FULL SCALE COMPONENT TESTING, LOGISTICALLY ACCEPTABLE REPAIR METHODS TO RESTORE FULL STRUCTURAL INTEGRITY TO MANY OF THE COMPONENTS EMPLOYING UNIQUE STRUCTURAL CONCEPTS AND MATERIALS. BOTH FIELD AND DEPOT LEVEL REPAIR CONCEPTS ARE UNDER DEVELOPMENT TO ADDRESS VARIOUS LEVELS OF DAMAGE SEVERITY. THE PROGRAM IS SCHEDULED FOR COMPLETION IN 1993 FOLLOWING FULL SCALE VALIDATION TESTING OF REPRESENTATIVE REPAIRED SUBCOMPONENTS AT THE NAVAL AIR DEVELOPMENT CENTER AND BELL HELICOPTER TEXTRON.



V-22 COMPOSITE REPAIR DEVELOPMENT

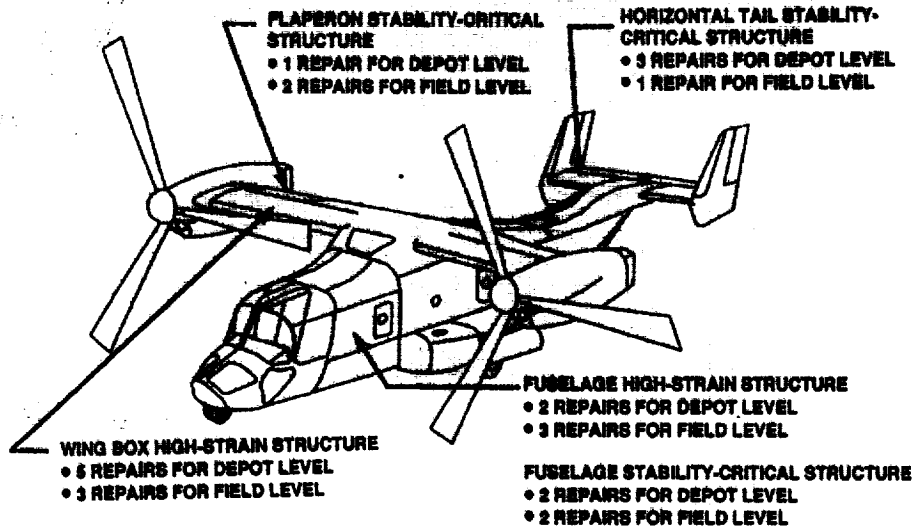

ABDR

- **DEVELOP PC BASED ANALYTICAL TECHNIQUES FOR RAPID REPAIR OF COMPOSITE WING STRUCTURES**
THIS COMPUTER CODE WILL PROVIDE AN ANALYTICAL TOOL TO AN AIRCRAFT BATTLE DAMAGE REPAIR ASSESSOR OR ENGINEER TO DETERMINE THE STRUCTURAL CONDITION OF THE UNDAMAGED, DAMAGED, AND REPAIRED STRUCTURE, IN LESS THAN ONE HOUR.
- **SIMPLIFIED ANALYSIS FOR RAPID DAMAGE ASSESSMENT/REPAIRS**
A PERSONAL COMPUTER BASED ANALYSIS PACKAGE TO ASSESS THE INTEGRITY OF LARGE SCALE RAPID REPAIRS IS BEING DEVELOPED FOR BOTH CURRENT AND EMERGING COMPOSITE WING STRUCTURES IN THE NAVY INVENTORY.
- **RAPID ANALYSIS FOR FIELDED DESIGNS**
A STRUCTURAL LIBRARY WILL CONTAIN DETAILED FINITE ELEMENT MODELS OF THE F/A-18, AV-8B, A-6 RETROFIT, AND V-22 WINGS. THE WING MODELS CAN BE MODIFIED INTERACTIVELY TO INCORPORATE LARGE SCALE DAMAGE IN SKINS AND SUBSTRUCTURE. BY USING USER-FRIENDLY AND MENU-DRIVEN INPUTS, REPAIRS CAN BE RAPIDLY DESIGNED FOR THE DAMAGE AT HAND.

THIS ANALYSIS CODE WILL ALLOW THE DESIGN OF SUBSTRUCTURE AND SKIN REPAIRS AND TAKE INTO ACCOUNT THEIR INTERACTION. THE CODE MAY BE EXPANDED TO INCLUDE OTHER COMPOSITE STRUCTURES SUCH AS THE FUSELAGE AND EMPENNAGE.



AIRCRAFT BATTLE DAMAGE REPAIR

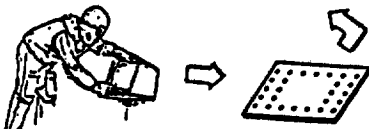
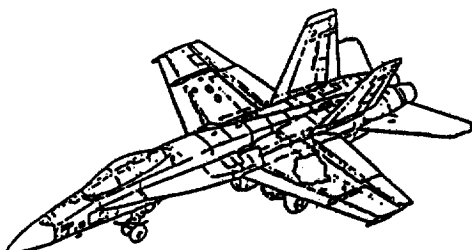

- **DEVELOP PC BASED ANALYTICAL TECHNIQUES FOR RAPID REPAIR OF COMPOSITE WING STRUCTURE**
- **SIMPLIFIED ANALYSIS FOR RAPID DAMAGE ASSESSMENT/REPAIR**
- **REPAIR ANALYSIS FOR FIELDED DESIGNS**
- **SKIN/SUBSTRUCTURE INTERACTION**

DESIGN ISSUES

THE INHERENT DIFFERENCES BETWEEN METALS AND COMPOSITES NECESSITATES NEW CERTIFICATION REQUIREMENTS.

OUT-OF-PLANE LOADING AND ASSEMBLY INDUCED DELAMINATIONS ARE CRITICAL ISSUES THAT MUST BE DEALT WITH IN DESIGN AND ANALYSIS BECAUSE OF THE LOW INTERLAMINAR STRENGTH OF COMPOSITES. THESE ISSUES ARE BEING WORKED JOINTLY BY THE NAVY AND THE FAA ARE DISCUSSED IN MORE DETAIL IN THE FOLLOWING VIEWGRAPHS.



DESIGN ISSUES



CERTIFICATION REQUIREMENTS

OUT-OF-PLANE LOADING

ASSEMBLY INDUCED DELAMINATIONS

NAVY STRUCTURAL CERTIFICATION METHODOLOGY

CAREFUL PLANNING AND COORDINATION BETWEEN THE NAVY AND THE CONTRACTOR ARE REQUIRED BEGINNING EARLY IN THE AIRCRAFT DEVELOPMENT PROGRAM.

THE DESIGN DEVELOPMENT TEST PROGRAM IS AN INTEGRAL PART OF THE CERTIFICATION PROCESS.

STATIC STRENGTHS GREATER THAN DESIGN ULTIMATE LOAD ARE REQUIRED FOR THE DESIGN DEVELOPMENT TEST SPECIMENS TO ACCOUNT FOR:

- ENVIRONMENTAL STRENGTH DEGRADATION DUE TO TEMPERATURE AND MOISTURE.
- THE INCREASED SCATTER IN MATERIAL PROPERTIES DEMONSTRATED BY COMPOSITES (WHEN COMPARED TO METALS).

FULL SCALE TEST RESULTS MUST CORRELATE WITH DESIGN DEVELOPMENT TEST RESULTS.

- MEASURED STRAINS IN CRITICAL AREAS MUST AGREE.
- FAILURE MODES MUST BE THE SAME.
- STATIC STRENGTH MUST ACCOUNT FOR SCATTER AND ENVIRONMENT.

ADEQUATE TIME AND RESOURCES MUST BE ALLOCATED FOR THE ENTIRE CERTIFICATION PROCESS.

SCHEDULE AND COST RESTRAINTS THAT LIMIT THE SCOPE OF THE DESIGN DEVELOPMENT PROGRAM INCREASE THE RISK OF UNSUCCESSFUL FULL SCALE TESTS.



NAVY STRUCTURAL CERTIFICATION METHODOLOGY



COUPON



ELEMENT

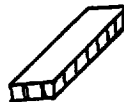

SUBCOMP

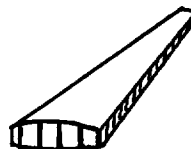

COMPONENT

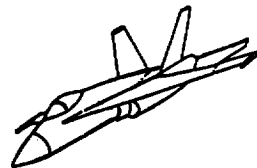

FULL-SCALE TESTS
STATIC
FATIGUE
FLIGHT

- CERTIFICATION BEGINS EARLY IN DEVELOPMENT PROCESS
- BUILDING BLOCK DEVELOPMENT APPROACH
- CAREFULLY COORDINATED DEVELOPMENT PLANNING
- ADEQUATE TIME AND RESOURCES

AV-8B COMPOSITE WING DEVELOPMENT

AN EXAMPLE OF AN IDEAL DEVELOPMENT PROGRAM IS THE AV-8B COMPOSITE WING. DUE TO THE EXISTENCE OF ADEQUATE TIME AND FUNDING, THE NECESSARY AMOUNT OF DEVELOPMENT AND PRE-PRODUCTION TESTING WAS PERFORMED PRIOR TO THE FABRICATION OF THE FULL STATIC TEST AIRCRAFT. THIS TEST PROGRAM INCLUDED COUPON TESTING TO OBTAIN MATERIAL ALLOWABLES, FOLLOWED BY JOINT AND SKIN PANEL TESTING. ONCE DESIGN PROPERTIES WERE OBTAINED, LARGER SUBSTRUCTURE ELEMENTS AND CRITICAL PORTIONS OF THE TORQUE BOX WERE FABRICATED AND TESTED. THIS APPROACH PROVIDES NECESSARY TEST DATA AND MANUFACTURING EXPERIENCE IN A TIME FRAME WHICH CAN IMPACT THE FINAL DESIGN.

THIS REPRESENTS AN IDEAL DEVELOPMENT PROGRAM FOR COMPOSITE AIRCRAFT STRUCTURE. HOWEVER, SCHEDULE AND COSTS RESTRAINTS OFTEN COMPROMISE THIS APPROACH. ALL EFFORTS SHOULD BE MADE TO FOLLOW THIS APPROACH TO INSURE A SUCCESSFUL FULL SCALE AIRCRAFT TEST.



AV-8B COMPOSITE WING DEVELOPMENT



1974 1975	Preliminary Design	
1975 Thru 1977	Design Allowables	
	Joints	
	Skins	
	Substructure	
	Box Beams	
1977	Operational Hazards	
1978	Static Wing YAV-83 Flight Demo	
1980 1981	FSD Static Airframe	
1981 1982	FSD Fatigue Airframe	
1984 On	Production Deliveries	

OUT-OF-PLANE ANALYSES

OUT OF PLANE STRESSES ARE AN ISSUE IN COMPOSITES BECAUSE OF THEIR LOW INTERLAMINAR STRENGTH. OUT OF PLANE STRESSES RESULT EITHER DIRECTLY FROM THE APPLICATION OF OUT-OF-PLANE LOADS, SUCH AS FUEL PRESSURE, OR INDIRECTLY, UNDER IN PLANE LOADING, AS A RESULT OF LAMINATE GEOMETRY SUCH AS LAMINATE CORNER RADI, PLY DROP-OFFS, STIFFENER RUN-OUT, AND PANEL BUCKLING DEFORMATION. WHILE THREE DIMENSIONAL FINITE ELEMENT METHODS CAN BE USED TO ANALYZE THESE SITUATIONS, THEY REQUIRE TOO MUCH TIME FOR PRELIMINARY STRUCTURAL SIZING.

IN A JOINT NAVY/FAA PROGRAM, THE PROBLEMS RESULTING FROM OUT-OF-PLANE LOADS WERE INVESTIGATED AND WAYS WERE DEVELOPED FOR AVOIDING FAILURES THAT ARE CAUSED BY THESE LOADS. SIMPLE TWO DIMENSIONAL ANALYSIS METHODS WERE DEVELOPED TO PREDICT OUT-OF-PLANE FAILURE STRENGTH OF COMPOSITE STRUCTURES. ELEMENT TEST DATA WERE USED TO VERIFY THE ANALYSES. THE METHODS AND EXPERIENCE FROM THIS PROGRAM WERE USED TO COMPILE A SET OF DESIGN GUIDES FOR DESIGNERS AND ANALYSTS.



POTENTIAL OUT-OF PLANE FAILURES

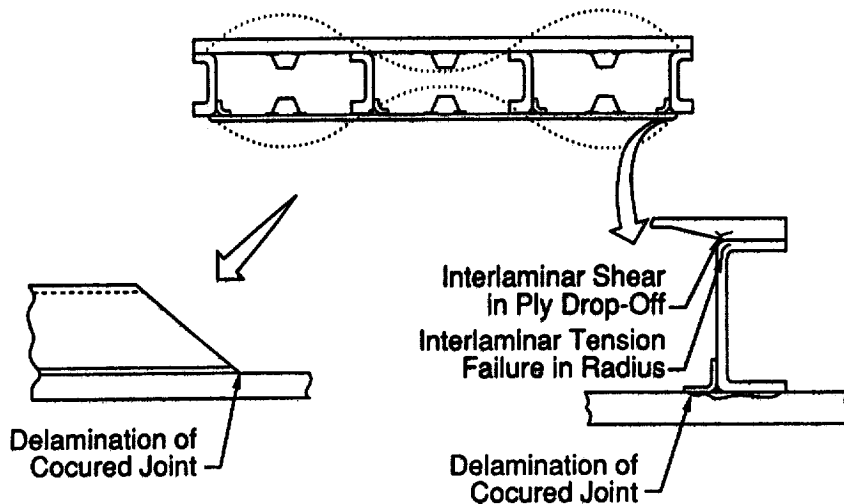

ASSEMBLY INDUCED DELAMINATIONS

EARLIER, I POINTED OUT A RECURRING PROBLEM IN MANUFACTURING, IN WHICH INTERPLY DELAMINATIONS OF WING SKINS AND SUBSTRUCTURE OCCUR DURING ASSEMBLY. FREQUENTLY THESE DELAMINATIONS ARE ASSOCIATED WITH IMPROPER FASTENER INSTALLATION OR IMPROPER SHIMMING OF MECHANICAL FASTENED JOINTS AS INDICATED ON THIS VU-GRAPH. THESE DELAMINATIONS CAN CAUSE SIGNIFICANT REDUCTION IN THE LOAD CARRYING CAPABILITY OF STRUCTURE, PARTICULARLY IN COMPRESSION STRENGTH AND IN THE STRENGTH OF STRUCTURE SUBJECTED TO OUT-OF-PLANE LOADING. IN ADDITION, THERE IS A POTENTIAL FOR DELAMINATION GROWTH UNDER FATIGUE LOADING, WHICH CAN FURTHER REDUCE LOAD CARRYING CAPABILITY. CURRENTLY, ANALYTICAL METHODS TO ASSESS THE EFFECTS OF THESE DELAMINATIONS DO NOT EXIST. NADC AND THE FAA JOINTLY HAVE INITIATED A PROGRAM TO:

- (1) DEVELOP AND VALIDATE A METHODOLOGY FOR ASSESSING THE SEVERITY OF KNOWN DELAMINATIONS WITH RESPECT TO THEIR EFFECTS ON STRENGTH AND LIFE SO REPAIR/REPLACEMENT DECISIONS CAN BE MADE.
- (2) PROVIDE DESIGN GUIDELINES FOR PREVENTION OF ASSEMBLY INDUCED DELAMINATIONS.

THIS WORK WILL BE REPORTED ON IN DETAIL DURING THIS CONFERENCE.



ASSEMBLY INDUCED DELAMINATIONS

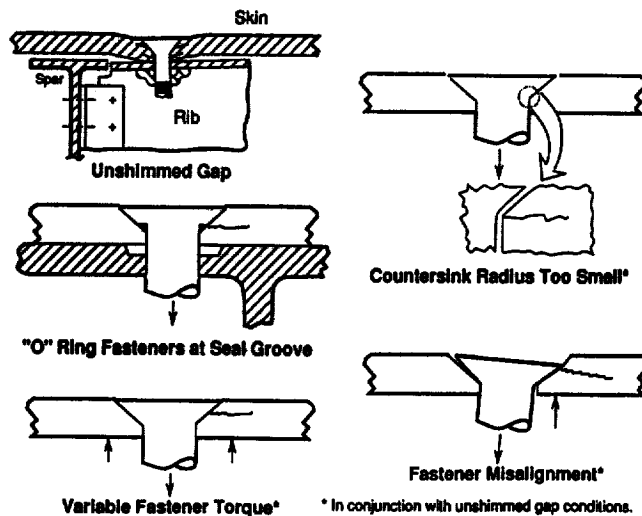

FUTURE COMPOSITE USAGE RATIONALE

IN THE FUTURE THE DRIVER FOR THE SELECTION AND USAGE OF A COMPOSITE MATERIAL WILL NOT BE SOLELY DEPENDENT UPON WEIGHT SAVINGS. OTHER MAJOR DRIVERS SUCH AS COST, MANUFACTURING QUALITY, DAMAGE TOLERANCE, SURVIVABILITY, OBSERVABILITY, SUPPORTABILITY, IN ADDITION TO RISK TO PROGRAM SCHEDULE AND AVAILABLE FUNDING MUST ALL BE TAKEN INTO CONSIDERATION. ONLY APPLICATIONS WHERE THE PAYOFF IS SUFFICIENT TO JUSTIFY THE USE OF ADVANCED COMPOSITES SHOULD BE CONSIDERED. ADDITIONALLY, TO INSURE THAT THESE PAYOFFS ARE REALIZED, BETTER METHODS FOR PREDICTING WEIGHT AND COSTS IN A MANUFACTURING ENVIRONMENT MUST BE DEVELOPED.

THE USE OF IMMATURE MATERIAL SYSTEMS MUST BE AVOIDED. PAST EXPERIENCE HAS SHOWN THAT THE COMMITMENT TO A MATERIAL SYSTEM PRIOR TO ITS COMPLETE CHARACTERIZATION RESULTS IN PERFORMANCE PENALTIES AND COSTLY PROGRAM DELAYS.

BUILDING A MILITARY AIRCRAFT REQUIRES SPECIALIZED EQUIPMENT AND EXPERIENCE RELATED TO COMPOSITE TECHNOLOGY. THE NAVY AND THE CONTRACTOR MUST REALIZE THAT THIS CAPABILITY NEEDS TO EXIST AT THE START OF THE DEVELOPMENT PROGRAM AND CANNOT EXPECT IT TO BE ACQUIRED DURING THE PROGRAM.

APPLICATIONS MUST TAKE ADVANTAGE OF THE AVAILABLE TECHNOLOGY BASE. SHOULD THE TECHNOLOGY FOR A SPECIFIC APPLICATION NOT EXIST AT THE PROGRAM ON-SET, THE RISK OF FAILURE CAN BE SIGNIFICANT.

FINALLY, IT MUST BE REALIZED THAT THE BEST MATERIAL FOR A PARTICULAR APPLICATION MAY NOT BE A COMPOSITE.



FUTURE COMPOSITES USAGE RATIONALE



- ALL KEY DRIVERS - WEIGHT, COST, RISK, ETC.
- PAYOFF VS. APPLICATION
- PROGRAMMATICS - SCHEDULE, FUNDING, ETC.
- MATURITY OF MATERIAL SYSTEMS
- CONTRACTOR EXPERIENCE AND CAPABILITY
- OVERALL TECHNOLOGY BASE VS. APPLICATION
- BEST MATERIAL NOT ALWAYS COMPOSITES

FUTURE PERSPECTIVE

THE NAVY IS COMMITTED TO, AND WILL CONTINUE TO USE, ADVANCED COMPOSITES ON ITS AIRCRAFT. THE MAJOR BENEFITS TO THE NAVY, REDUCED WEIGHT, INCREASED FATIGUE LIFE AND CORROSION RESISTANCE, FAR OUTWEIGH THE LIMITATIONS DISCUSSED. THESE LIMITATIONS ARE NOT CONSIDERED SHOW-STOPPERS AND ARE, AND WILL CONTINUE TO BE, WORKED THROUGH R&D AND MANTECH PROGRAMS. THE TECHNOLOGY WILL CONTINUE TO EVOLVE WITH CONTINUING EMPHASIS ON REDUCING COSTS AND IMPROVING QUALITY THROUGH AUTOMATION. IN ALL CASES THE COSTS ASSOCIATED WITH THE USE OF COMPOSITES MUST BE JUSTIFIED.

IN THE MATERIALS SELECTION AREA, THERMOSETS WILL CONTINUE TO BE THE PRIMARY MATERIAL IN THE FORESEEABLE FUTURE DUE TO THEIR MATURITY AND THE EXISTENCE OF AVAILABLE CAPITAL EQUIPMENT (AUTOCLAVES).

THE ISSUES OF LOW OBSERVABILITY AND SUPPORTABILITY WILL TAKE ON ADDITIONAL IMPORTANCE IN THE FUTURE.



FUTURE PERSPECTIVE



- **EVOLUTIONARY DEVELOPMENT OF TECHNOLOGY**
- **NAVY AIRCRAFT WILL CONTINUE TO USE COMPOSITES**
- **APPLICATIONS WILL HAVE TO JUSTIFY INCREASED COST**
- **QUANTUM ADVANCEMENT NEEDED IN MANUFACTURING**
- **MANUFACTURING QUALITY MUST BE IMPROVED**
- **THERMOSETS CONTINUE TO BE THE PRIMARY MATERIAL IN THE FORESEEABLE FUTURE**
- **LOW OBSERVABILITY WILL BE A DESIGN DRIVER**
- **SUPPORTABILITY WILL BE INCREASINGLY IMPORTANT**

**Advanced Materials Requirements and Needs
for Future Aerospace Applications**

**Samuel L. Venneri
National Aeronautics and Space Administration
Office of Aeronautics, Exploration and Technology**

THIS PAGE INTENTIONALLY BLANK

omit

SESSION II
AIRCRAFT DESIGN METHODOLOGY (A)

PRECEDING PAGE BLANK, NOT FILMED

THIS PAGE INTENTIONALLY BLANK