

1995-122613



ADVANCED COMPOSITE FUSELAGE TECHNOLOGY¹

55-24
51238

Larry B. Ilcewicz, Peter J. Smith, and Ray E. Horton
Boeing Commercial Airplane Group
Seattle, WA

ABSTRACT

Boeing's ATCAS program has completed its third year and continues to progress towards a goal to demonstrate composite fuselage technology with cost and weight advantages over aluminum. Work on this program is performed by an integrated team that includes several groups within The Boeing Company, industrial and university subcontractors, and technical support from NASA. During the course of the program, the ATCAS team has continued to perform a critical review of composite developments by recognizing advances in metal fuselage technology. Despite recent material, structural design, and manufacturing advancements for metals, polymeric matrix composite designs studied in ATCAS still project significant cost and weight advantages for future applications. A critical path to demonstrating technology readiness for composite transport fuselage structures was created to summarize ATCAS tasks for Phases A, B, and C. This includes a global schedule and list of technical issues which will be addressed throughout the course of studies.

Work performed in ATCAS since the last ACT conference is also summarized. Most activities relate to crown quadrant manufacturing scaleup and performance verification. The former was highlighted by fabricating a curved, 7 ft. by 10 ft. panel, with cocured hat-stiffeners and cobonded J-frames. In building to this scale, process developments were achieved for tow-placed skins, drape formed stiffeners, braided/RTM frames, and panel cure tooling. Over 700 tests and supporting analyses have been performed for crown material and design evaluation, including structural tests that demonstrated limit load requirements for severed stiffener/skin failsafe damage conditions. Analysis of tests for tow-placed hybrid laminates with large damage indicates a tensile fracture toughness that is higher than that observed for advanced aluminum alloys. Additional recent ATCAS achievements include crown supporting technology, keel quadrant design evaluation, and sandwich process development.

INTRODUCTION

The timely development of advanced composite technologies for wing and fuselage structures will ensure that U.S. manufacturers maintain a majority share of the world

¹ This work was funded by Contract NAS1-18889, under the direction of J.G. Davis and W.T. Freeman of NASA Langley Research Center.

market for transport aircraft. The US government currently finances such developments under the NASA funded Advanced Composite Technology (ACT) program. Developmental funding such as ACT is crucial to the future of the U.S. aircraft industry and, since a large number of commercial aircraft manufactured in the U.S. are sold abroad, provides long term national benefits. Quoting from the AIAA Bulletin, July 1992, "the U.S. aerospace industry is our country's largest exporter of manufactured goods, generating a \$30-billion trade surplus in 1991." In addition to financial support, NASA personnel provide technical direction and support for solving difficult issues associated with the advancement of composite manufacturing, materials, and structures within the ACT program.

Boeing's NASA-funded program entitled Advanced Technology Composite Aircraft Structure (ATCAS) has been active for more than three years. As stated, the objective of this program is to "Develop an **integrated technology** and demonstrate a confidence level that permits the **cost and weight-effective** use of **advanced composite materials in transport fuselage structures for future aircraft**". The three statements highlighted with bold print represent *how*, *why*, and *what*, with respect to ATCAS activities.

This paper constitutes a technical overview of the ATCAS program and is broken into four main parts. The first section reviews the integrated team approach used in ATCAS and introduces team members supporting the program. The remaining three sections give details on (1) *why* ATCAS believes composite technology will replace aluminum in future fuselage barrel structures; (2) the critical path of *how* ATCAS is pursuing this technology; and (3) *what* ATCAS has achieved since the last ACT conference.

ATCAS TEAM MEMBERS

Early efforts in ATCAS dedicated a significant amount of time to developing a design build team (DBT) approach to concept selection, evaluation, and optimization (see References 1 and 2). This approach provided each member with a sense of ownership in program accomplishments. Initial team developments were not always achieved efficiently and were often the result of long periods of intense discussion which eventually resulted in a compromise between the various engineering and manufacturing disciplines. As time progressed, individual team members became more aware of the overall ATCAS plan and technical issues associated with composite fuselage structures. Less time was spent in DBT meetings because the agendas were clearly defined and team members learned to work closely together without the formalization of a scheduled meeting. As a result, the ATCAS team approach has matured further, yielding timely solutions to the multidiscipline problems which need to be addressed on a critical path to composite fuselage technology development.

The total number of people which have worked ATCAS tasks at Boeing is on the order of 100. The primary ATCAS team members from Boeing Commercial Airplane Group (BCAG) are listed in Figure 1.

Additional team members crucial to the ATCAS program include personnel from other Boeing divisions and industry within the U. S. Figures 2 and 3 list these personnel, their

affiliation, and companies' location in the western and eastern portions of the U.S. Those groups highlighted in bold print have co-authors that directly supported ATCAS papers presented at this conference.

Program Manager: R. Horton	Manufacturing R&D: K. Willden	Structural Mechanics: T. Walker
Technology Manager: P. Smith	T. Davies	E. Dost
Principal Investigator: L. Ilcewicz	M. Gessel	G. Swanson
Business Management: M. Apeles	K. Goodno	B. Flynn
Structural Design M. Morris	V. Starkey	J. Bodine
K. Griess	Material & Processes: D. Scholz	G. Mabson
M. Schramm	D. Grande	Cost Estimating: B. Humphrey
S. Metschan	Operations Technology: J. Valdez	K. Venters
Weights Engineering: G. Parkan	B. Luck	D. Tervo
	NDE Development: B. Lempriere	L. Witonsky
	S. Finn	Technical Support: W. Waltari
		T. Le

Figure 1. ATCAS team members from Boeing Commercial Airplane Group.

Company	Location	People	Work description
Boeing Defense & Space Group	Kent, WA	W. Avery, K. Nelson, D. Pollard	Fabrication analysis and test
Boeing Computer Services	Bellevue, WA	B. Dopker, W. Koch, R. Lundquist, D. Murphy	Computational structural mechanics
Hercules Inc.	Salt Lake City, UT	C. Grant, G. Walker, Y. Tokita, T. Brown, D. Cairns, D. Cohen	Advanced tow placement technology
Zetec Inc.	Issaquah, WA	C. Fitch, G. Colvin, J. Siegel, P. Spencer	Flexural wave inspection/damage characterization
ICI Fiberite	Tucson, AZ	R. Hoelthe	Tow and tape materials
Integrated Technology Inc.	Bothell, WA	B. Coxon	<ul style="list-style-type: none"> • Element and coupon testing • Stiffened panel impact
The Dexter Corporation Hysol Aerospace Products	Seattle, WA	J. Montgomery	Syntactic foam materials
Hexcel	Dublin, CA	F. Lee, Y. Wang	Sandwich core material processes
Hydrosabre Technologies Inc.	Kent, WA	J. Hillman	Water-jet machining
Northrop Corp.	Hawthorne, CA	R. Deo, R. Vaslava	Design cost trade studies for fuselage cutout details
TORR Technologies	Auburn, WA	G. Lindstrom	Silicon reusable vacuum-cure bag
Engineering consultant	Bellevue, WA	J. McCarty	Fuselage structures
Aircraft Products	Anaheim, CA	P. Foscett	Silicone extrusions



Figure 2. Other Boeing and industrial groups supporting ATCAS: western United States.

Company	Location	People	Work description
Boeing Helicopters Division	Philadelphia, PA	C. Gunther, P. Grant, M. Fedro, A. Sawicki	<ul style="list-style-type: none"> • Braided composite mechanics • Bolted and bonded joints
Sundstrand Aerospace	Rockford, IL	H. Saatchi, W. Durako, R. Reynolds	In situ foam process development
Dow UTC	Wallingford, CT	R. Andelman	Design-cost relationships for textile processes
Sikorsky Aircraft	Stratford, CT	C. Kassapoglou	Design and cost constraints for sandwich structure
Fiber Innovations	Norwood, MA	G. Sharpless	Braided preform and RTM process development
Materials Sciences Corp.	Blue Bell, PA	A. Caiazzo, W. Rosen	Keel design stability analysis
3M	St Paul, MN	W. Schultz, G. Vandesteeg	Powder-epoxy materials
Foster Miller Inc	Waltham, MA	G. Freitas	Z-reinforcement technology



Figure 3. Other Boeing and industrial groups supporting ATCAS: eastern United States.

To date, the expanded composite expertise that other Boeing divisions and industrial subcontracts bring to the ATCAS team has well justified the additional coordination efforts by BCAG. Detailed monthly reports published for ATCAS serve as an efficient means for continually updating team members on the overall program status and schedules.

Several university subcontracts and co-op students also support ATCAS. Figure 4 shows the universities which were active during the last year and their individual work tasks. Those highlighted in bold print are currently still supporting the program. University subcontracts have been found to require significantly more time to coordinate efforts that directly support the hardware application goals of ATCAS. The additional time required to coordinate university work is primarily due to an education gap that is related to a difference between issues addressed in academia and industry. The Boeing Company recognizes this and has plans to close the gap.

The ATCAS program reflects Boeing's commitment to improving college relations through a close tie with the university subcontracts. Most ATCAS subcontracts which are still active have been focused to specific hardware issues, providing both student and faculty with educational benefits associated with real-world problem solving. Boeing coordination has provided descriptions of fuselage structures and their function, associated problem definitions, test data, and a technical assessment of progress. Technology transferred from university subcontracts to ATCAS team members has been timely, allowing developments to be integrated into design, fabrication, analysis, and testing of major hardware articles. Again, a commitment to detailed monthly reports have been helpful for task coordination and review.

Several lessons learned from the infusion of university subcontracts in ATCAS are worthy of note. First, it is best to select baseline design concepts, define related technical issues, and collect some hardware data before establishing a subcontract. In other words, define problems that relate to the program focus. Second, the solution to many industrial problems requires a multidiscipline approach, again highlighting the need for close

coordination between the DBT and any subcontract. Finally, sufficient manpower and time must be allocated to facilitate education and technology transfer between industry and academia. Schools that encourage student co-op programs and graduate students or faculty that have had industrial experience can help minimize the coordination effort.

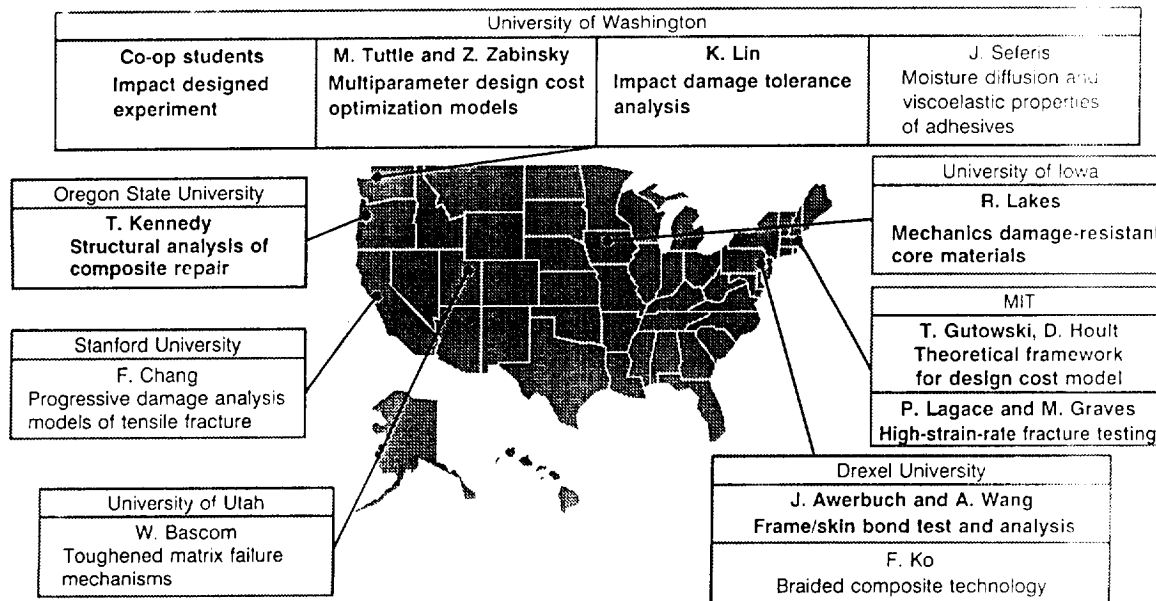

Figure 4. University subcontracts supporting ATCAS.

Several other partners have helped focus and support ATCAS technology development. These include Boeing programs for composite internal research and development, composite 777 empennage, and metal fuselage. Several U.S. airlines (American, United, and Northwest) have reviewed Boeing ATCAS design concepts and associated technology issues (repair and inspection). The Hercules ACT program continues to provide ATCAS with manufacturing and test hardware. The Lockheed ACT program is working to develop and optimize textile technologies for fuselage framing elements. The Lockheed efforts are currently coordinated with the ATCAS DBT for keel and side panels and will eventually yield parts for manufacturing trials and structural tests. As mentioned earlier, personnel from NASA Langley have contributed to ATCAS with analysis, mechanical tests, technical direction, and continuous management review. Although ACT program focussing and the integration of a larger team have not come without growing pains, the overall benefits are evident in ACT achievements.

COMPOSITE VERSUS METALS TECHNOLOGY OVERVIEW

ATCAS Approach and Schedule

An aft fuselage barrel, Section 46 of a wide body aircraft (20 ft. diameter), was selected for Phases A and B studies in ATCAS. As shown in Figure 5, four "quadrant type sections" (crown, keel, and left & right sides) constitute major panel assemblies around

the circumference of the composite study section. The metal counterpart has ten panels that splice to make up a barrel section. As discussed in reference 1, quadrants were selected for ATCAS during baseline trade studies which indicated that automated manufacturing methods for large composite panels are cost competitive with aluminum construction.

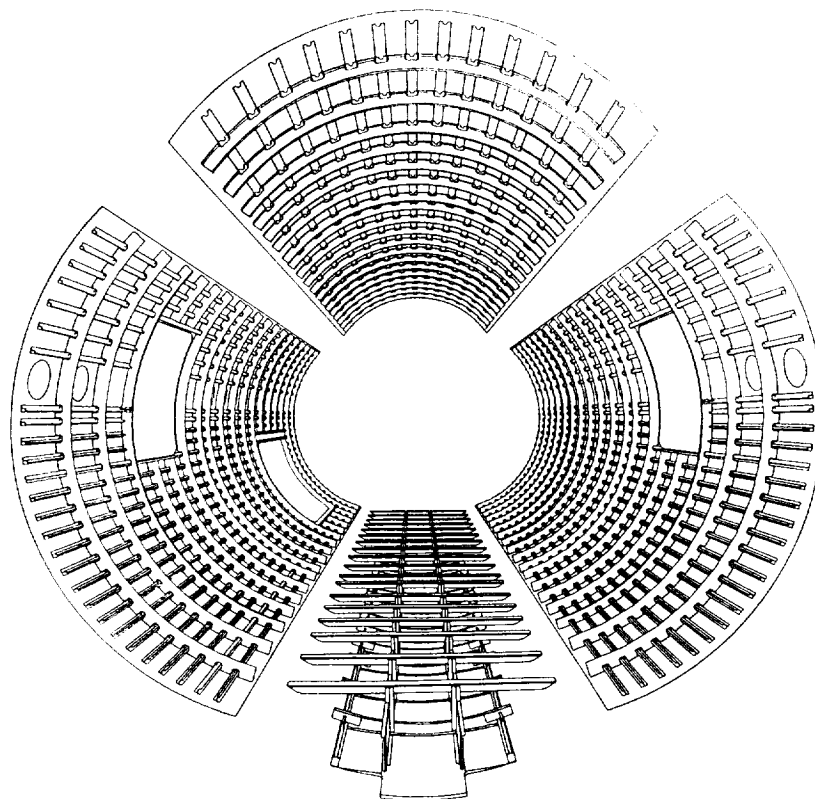

Figure 5. ATCAS quadrants for aft fuselage section.

During the first year of ATCAS, baseline design, manufacturing processes, and materials were selected for the four quadrants shown in Figure 5. Figure 6 shows timelines for work on each quadrant and major panel splices. Work is nearly completed for the crown quadrant. Efforts on the keel quadrant have progressed to local optimization. Keel scaleup and verification will be completed for aft portions of the panel approximately one year before those in the more difficult forward end. Side quadrant cost and weight evaluation is about to start. It will progress in close coordination with the Lockheed ACT program. Local detail studies for splices have just started for the crown and keel quadrants. Note that initial design efforts with major longitudinal and circumferential splices occurred during global evaluation for each of these quadrants.

The primary reason *why* ATCAS is pursuing its objective is to ensure readiness to take advantage of cost and weight savings projected for future composite technology. References 1 and 2 give detailed descriptions of the baseline concepts, associated technical issues, and the global/local DBT approach used to evaluate cost and weight. During global evaluation, initial cost/weight comparisons are made between the ATCAS baseline concept, alternative composite designs, and aluminum technology projected for

1995. This helps to select concepts that: (1) have cost and weight savings potential, justifying more detailed study and (2) have acceptable risk for manufacturing scaleup and test verification within the scheduled timeframe. Attempts to minimize cost and weight focus on the details of a single concept during local optimization. During local studies the DBT gains better understanding of the technical issues, manufacturing cost, material performance, structural design details, and critical interactions. An update on the cost and weight comparison with aluminum fuselage technology is also obtained during this phase of study. Global/local efforts by the DBT continue to justify *why* ATCAS is pursuing composite technology by keeping track of metal fuselage advancements as the composite design matures. At the end of studies for each quadrant, more accurate cost and weight comparisons will be made based on the results of manufacturing trials and major tests.

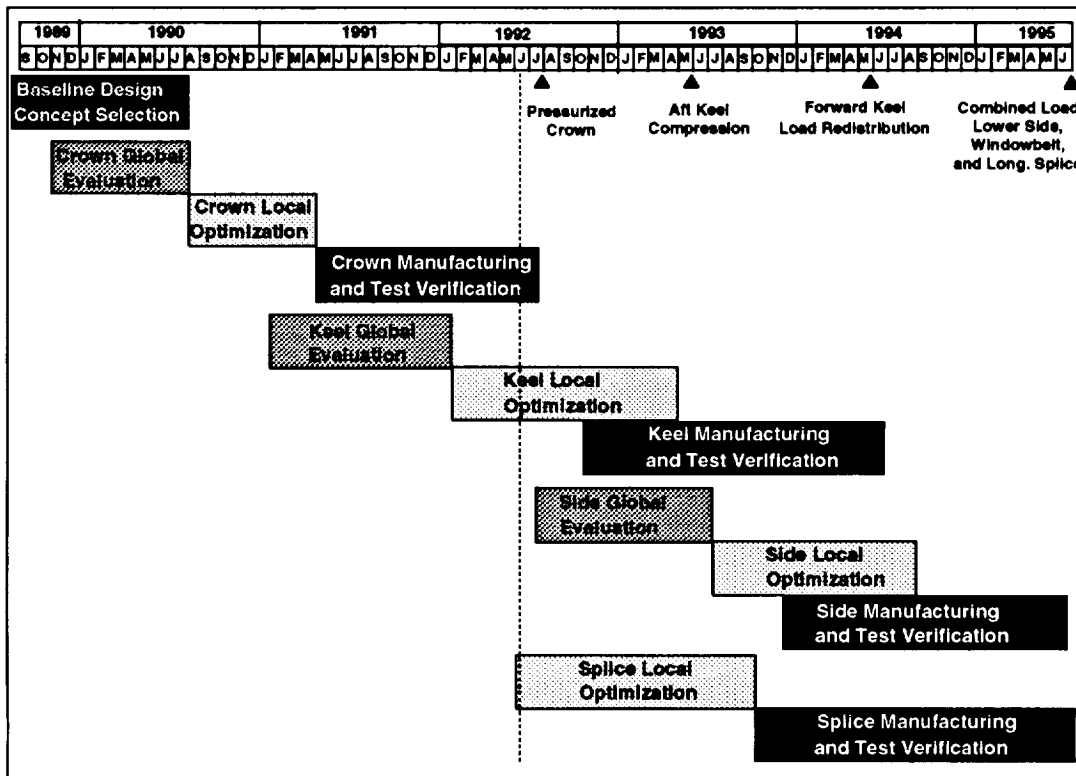

Figure 6. Timelines for crown, keel, side, and splice studies.

Crown Quadrant

Local optimization for the crown was completed in 1991. Since that time, the comparative metal technology has not remained stagnant. Consequently, there was a desire to update trade studies to account for advances in metal technology. In addition, the baseline fuselage configuration changed, affecting loads. Information from crown panel manufacturing trials also lead to a desire to redesign some ATCAS crown structural details. Finally, there was a desire to change ATCAS crown quadrant size from 90° to 99°. All of these issues and the associated ATCAS design changes were addressed at the same time. Technical details of these changes will be discussed in the

final section of this paper. Figure 7 shows the current cost/weight relationship between the updated ATCAS crown concept and advanced aluminum technology. A line is shown to represent the cost/weight trade potential of aluminum structural design concepts, advanced alloys, and manufacturing processes. Note that the composite concept has lost some of its potential weight savings versus that shown in reference 3. This is due to the metal advances, a more detailed investigation of fuselage requirements, and composite design changes.

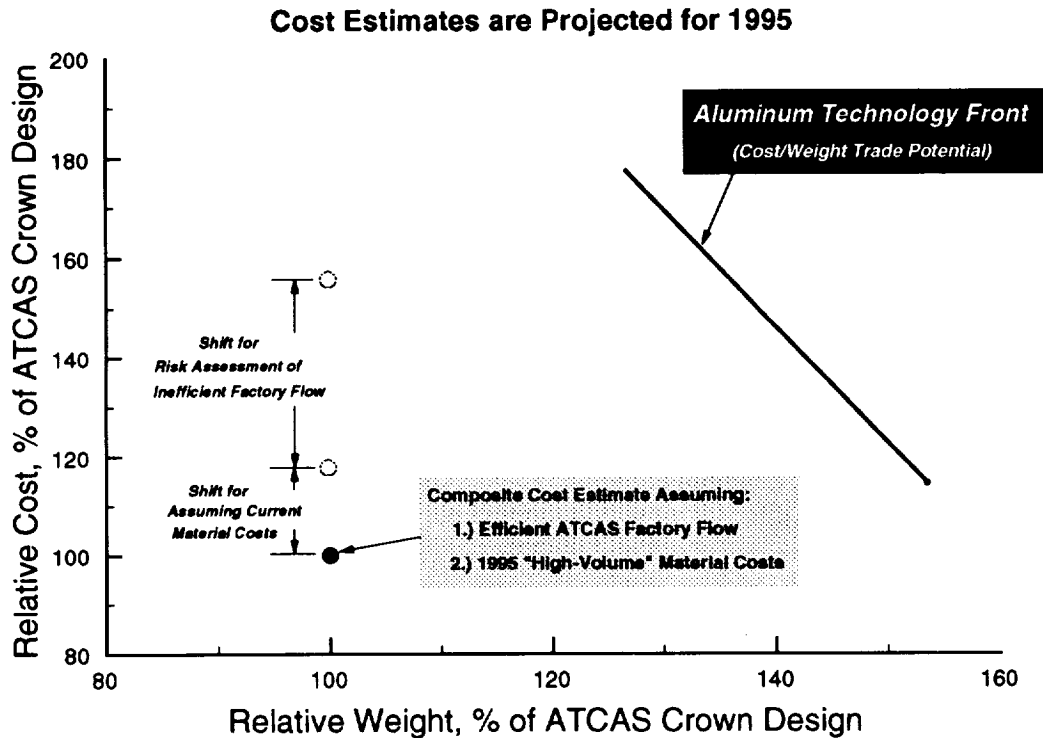

Figure 7. Fuselage crown panel cost/weight comparisons

Trade study results in Figure 7 indicate that the composite concept has potential for significant cost and weight savings as compared to advanced aluminum technology. Assumptions which are critical to these projections include reduced composite material costs and efficient ATCAS factory flow. Current material costs would drive the total cost of the composite crown quadrant up by approximately 20%. An even larger potential cost increase is projected if an efficient factory flow is not achieved. This risk relates to the problem whereby actual design details selected for the structure cause inefficient factory processing (e.g., defect control, machine maintenance, and increased touch labor). Design changes late in a hardware program, which can be forced by factors outside the control of a DBT, could negatively impact nonrecurring tooling costs. Such an effect can be large and is beyond that which is estimated in the risk analysis for Figure 7. A flexible tooling approach is needed to reduce the chance of such problems occurring in a hardware program. Less advancements in the composite manufacturing technology than projected would also increase costs. The study and control of factors affecting the cost of selected processes constitutes efforts being spent on an ACT design cost model. More will be said on this subject later.

Strength Versus Toughness Trades

Several design drivers were important to sizing the ATCAS crown quadrant. These included tension damage tolerance (axial and hoop), panel stability under compression and shear load conditions, minimum skin gage for hail impact, and minimum panel stiffness requirements for overall aircraft stability. In addition to the study section, these design approximately 70% of fuselage area (minimum gage panels). At the start of ATCAS, very little information existed to support the design of composite structures with large damage sizes representative of failsafe conditions. To date, ATCAS crown tasks have included the collection of composite tension fracture data and the application of existing methods for predicting damage tolerance. The latter subject will be covered in the last section of this paper. A review of the fracture data is given here to facilitate a comparison with aluminum alloys used in metal design.

Figure 8 shows tensile residual strength curves generated from small and large notch data for alloys used in aluminum fuselage and for composite laminates studied in ATCAS. A large database supports the metals curves shown in Figure 8, while ATCAS residual strength tests for IM7/8551-7 tape and AS4/938 tow-placed laminates include notch sizes up to 12 in. (refs. 4 and 5). A strength versus toughness trade is apparent in both classes of materials. For example, 7075-T651 and IM7/8551-7 both have high undamaged strengths but lower fracture toughness (i.e., greater notch sensitivity as shown by the rate of decrease in residual strength with increasing notch size) than the other two materials. The lower toughness relates to the small damage zones that occur at a loaded notch tip in 7075-T651 and IM7/8551-7 and the resulting inability to relieve local stress intensity.

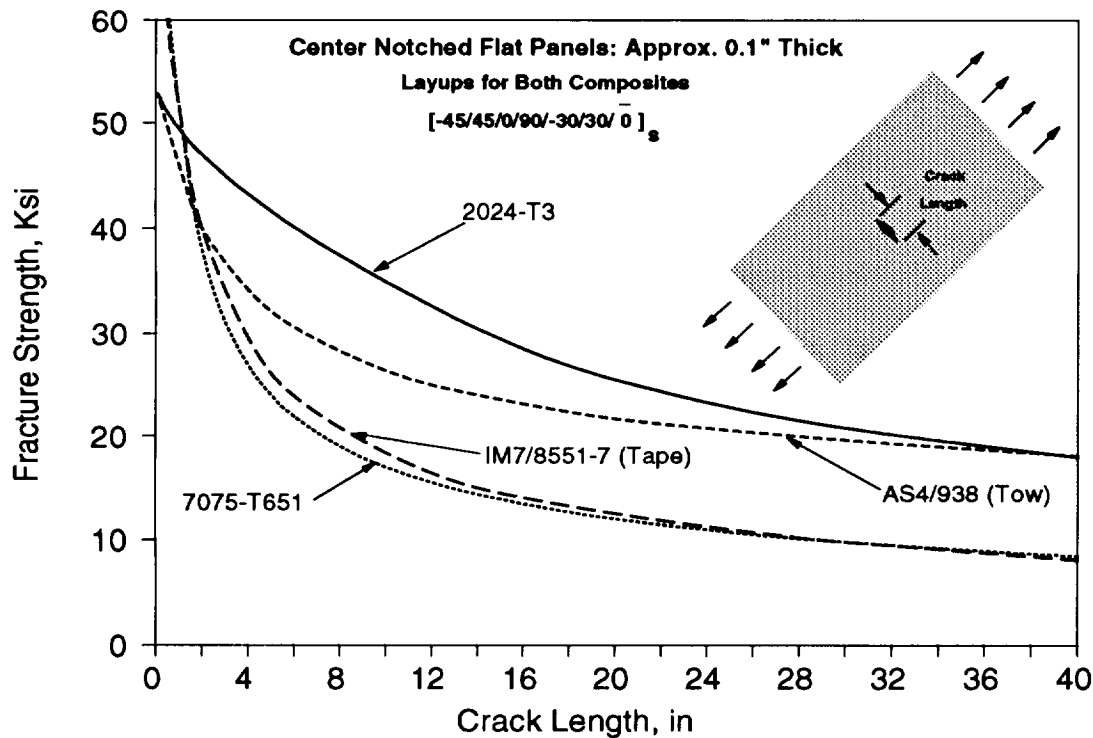

Figure 8. Tension residual strength curves for aluminum and composite materials.

The 2024-T3 aluminum gets its relatively high fracture toughness from crack tip yielding (i.e., plasticity), while AS4/938 gets relief from the notch tip stress intensity through other mechanisms such as matrix cracking and delamination. These same mechanisms lead to relatively low small notch strengths for both 2024-T3 and AS4/938. In metals, the phenomena is referred to as "net section yield". Note that the curve for AS4/938 has a different shape. This is possibly due to a differing relationship with finite panel width, a trait that tends to mask the material's high fracture toughness until larger notch and panel sizes are tested. The lower tensile residual strengths for IM7/8551-7 tape with large damage indicate composite materials that resist some modes of matrix damage (labeled "tough" in past literature) may not be suitable for fuselage skins.

Strength versus toughness trades are well recognized for aluminum alloys used in transport fuselage design (e.g., ref. 6). Skin typically consists of a material with low yield strength and high plane stress fracture toughness (e.g., 2024-T3). This helps to resist skin damage growth under fatigue and also leads to higher stiffened panel residual strength. An advanced aluminum alloy referred to as C-188 has somewhat higher toughness, without reduction in yield strength. This alloy appears attractive for future applications because skin forming processes have been demonstrated with the material at a large scale. Stiffening elements generally make use of alloys with significantly higher yield strength and lower toughness (e.g., 7075-T651). This promotes damage arrestment (failsafe design) and also leads to higher stiffened panel residual strength. The aluminum fuselage is actually a composite optimized for the design requirements; and hence, a better understanding of the years of experience behind such structures can be useful for polymeric composite design. In fibrous polymeric composites, residual strength for accidental damage threats and failsafe design practices become the important issues, while fatigue related skin crack growth similar to that encountered in metals is probably not a problem.

Figure 9 shows the strength versus toughness property trades for several other metals considered in fuselage structures and composite laminates tested thus far in ATCAS. Two sets of X and Y-axes appear in the figure, one for composite laminates and the other for metal alloys. The two X-axes show properties related to strength and "Ultimate" design load requirements (i.e., yield strength for metals and small notch strength for composites). The two Y-axes show properties related to large damage tolerance (i.e., plane stress fracture toughness for metals and an effective fracture toughness parameter representative of large notch data for composites). The location of specific metal alloys on the curve depends on % constituents, grain size, and associated process variables (e.g., heat treatment and stretch forming). In an analogous manner, the position of composites on the figure depends on several material, laminate, and manufacturing process variables. In general, "toughened" matrices, hard layups, and smaller levels of repeatable microstructure lead to high strength and low toughness. Hybridization, "brittle" matrices, soft layups, and larger levels of repeatable microstructure tend to lead to lower strength and high toughness. References 4 and 5 give additional details related to the composite database.

Results given in Figure 9 (plotted as stress parameters) and supporting technical reports represent one of the most significant findings in ATCAS to date. In particular, large

panel tests made possible by ACT funding show that composites considered for advanced fuselage have mechanical properties that are competitive with metal alloys currently used in fuselage. Some composite laminates (e.g., [-45,45,0,90,-30,30,0,30,-30,90,0,45,-45], IM7/8551-7 tape) are shown to have higher strengths than 7075-T6. Other composite laminates (e.g., tow-placed intraply hybrids) have an effective fracture toughness that is significantly higher than 2024-T3. The baseline crown material for ATCAS, tow-placed AS4/938, can trade a wide range of strength and toughness through layup changes. In summary, the advanced technology potential of lower density composite laminates appears very attractive for future applications in minimum gage areas of a fuselage.

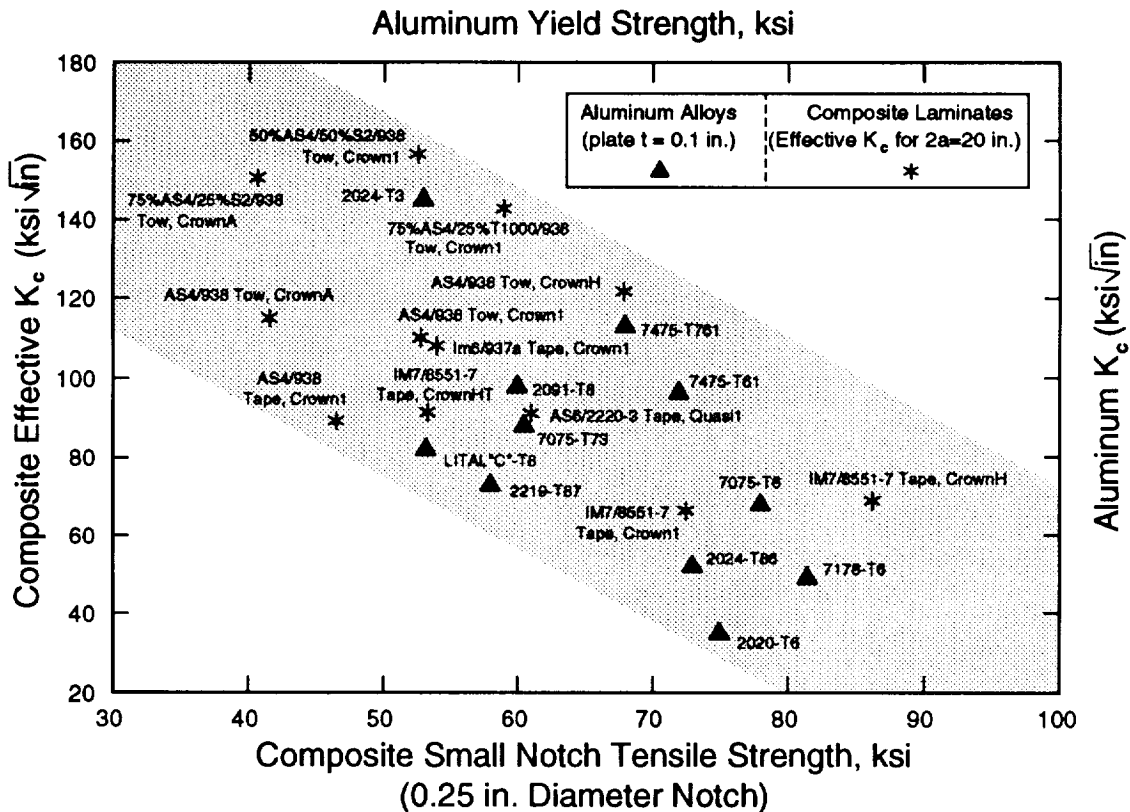

Figure 9. Tension strength versus toughness trades for metals and laminated composites.

Keel Quadrant

Global evaluation of the keel was completed in early 1992, including cost and weight trades between baseline sandwich (Family D) and alternate stiffened panel (Family C) designs. This initial design work for the keel was significantly more difficult than the crown global evaluation due to major load redistribution at the forward end (a result of the large wheel well cutout in the wing/body intersection) and associated design requirements. Composite manufacturing processes suitable for the structural design detail used in aluminum construction would yield high cost and weights. As a result, innovative "panelized keel beam" (i.e., thick laminate) design concepts were pursued to replace discrete keel beam chords at the forward end of the keel quadrant. A panelized

concept was designed for both Families C and D designs. Based on the results of this study, the baseline sandwich design was the desired candidate for more detailed local optimization work. In addition to cost and weight trades, this DBT decision was based on an assessment of technical issues which need to be addressed and the associated risk of demonstrating manufacturing and test verification within the scheduled timeframe. Note that some of the technical issues for a sandwich design have been studied since it was selected as the baseline concept in 1990. Another paper presented at this conference (ref. 7) describes keel global evaluation in detail.

Figure 10 compares the composite Family D keel concept selected for detailed studies and the aluminum technology front. Note that the difference between composite and aluminum weight is significantly less than currently projected for the crown quadrant (see Figure 7). Cost is projected to be competitive with aluminum, as was the case for the best designs and processes from crown global evaluation. A local optimization target zone is shown in Figure 10, representing estimates of additional cost and weight savings possible during more detailed studies. The best scenario projects an additional 20% cost and weight savings. Note how points in Figure 10 shift based on the ability to realize projected material costs and factory efficiency. Discussions given earlier in reference to Figure 7, also pertain to these cost risks.

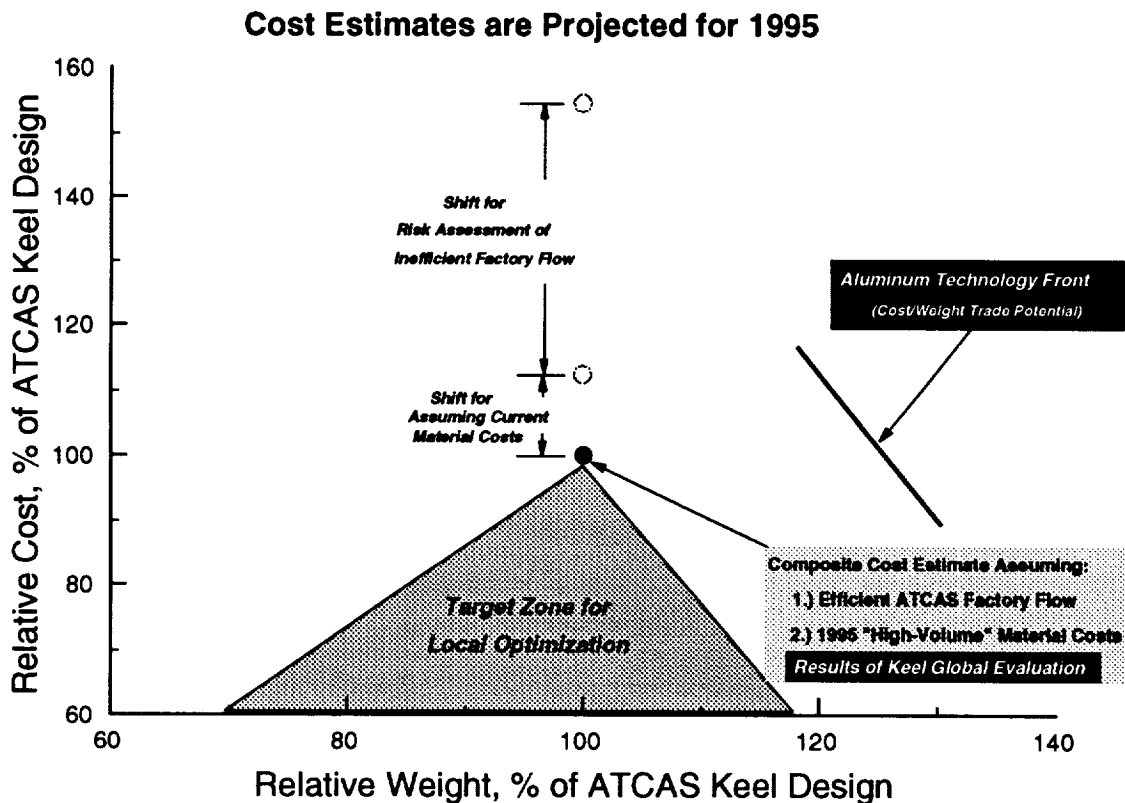

Figure 10. Fuselage keel panel cost/weight comparisons.

CRITICAL PATH TO TRANSPORT FUSELAGE

Phase C Description

As discussed at the start of the last section, an integrated team approach is being used by ATCAS to develop and verify advanced composite technology for transport fuselages. Phases A and B will be completed in 1995, providing a subcomponent database for quadrants and major splices in the full barrel study section. Boeing is currently proposing a Phase C effort to start in 1995. Phase C will concentrate on full-scale manufacturing demonstration and structural verification of the fuselage technology currently being investigated. This section will describe *how* a critical path will be pursued through Phases A, B, and C to be "technology ready" for a composite transport fuselage application.

The combination of manufacturing trials, test database, and supporting analyses from the first two phases will provide fuselage barrel design tools for Phase C. Materials, design concepts, and manufacturing processes are currently selected by DBT cost/weight trades before committing to manufacturing trials and major tests. The DBT also identifies critical issues to solve for selected concepts and then defines appropriate process and test plans. Information collected in fabrication trials (i.e., tooling development and curved panel scaleup) include documentation of process steps, nondestructive inspection data, dimensional tolerance measurements, and cost data. Mechanical tests yield a database to characterize material properties, textile fiber architecture, laminate layup, and structural design details. Building block tests for the latter range from stiffening elements and large unstiffened skin panels to curved subcomponent panels that include stiffeners and frames. An understanding of manufacturing and performance relationships with structural details is critical to the hardware database needed to support Phase C design. As a result, composite parts from process trials are used for mechanical tests. Analyses to support the database include developments in mechanics of materials, structural mechanics, manufacturing science, and design cost modeling.

Phase C will continue to develop and document supporting materials, structures, and manufacturing technologies which facilitate future applications to fuselage sections. Another part of Phase C includes a study to resolve critical issues for the wing/fuselage intersection. This effort will start with DBT cost/weight trades and culminate with detail design, fabrication, analysis, and test of selected structural components (e.g., keel beam). Phase C culminates with a full-scale demonstration of the ability to design and fabricate a fuselage barrel section with predictable performance and manufacturing cost.

Detailed critical path schedules have been developed to guide ATCAS Phase A and B efforts. The scheduled length of bars and associated descriptions shown at the top of Figure 11 (i.e., before the marker indicating an end of ACT Phases A and B) summarize tasks from more detailed schedules. Shaded bars highlight achievements to date. A description and time estimate of major Phase C tasks that complete the critical path to technology readiness are also shown in Figure 11. These tasks span a period from 1995 to 2002. More accurate schedules for these tasks will be created by the end of 1992.

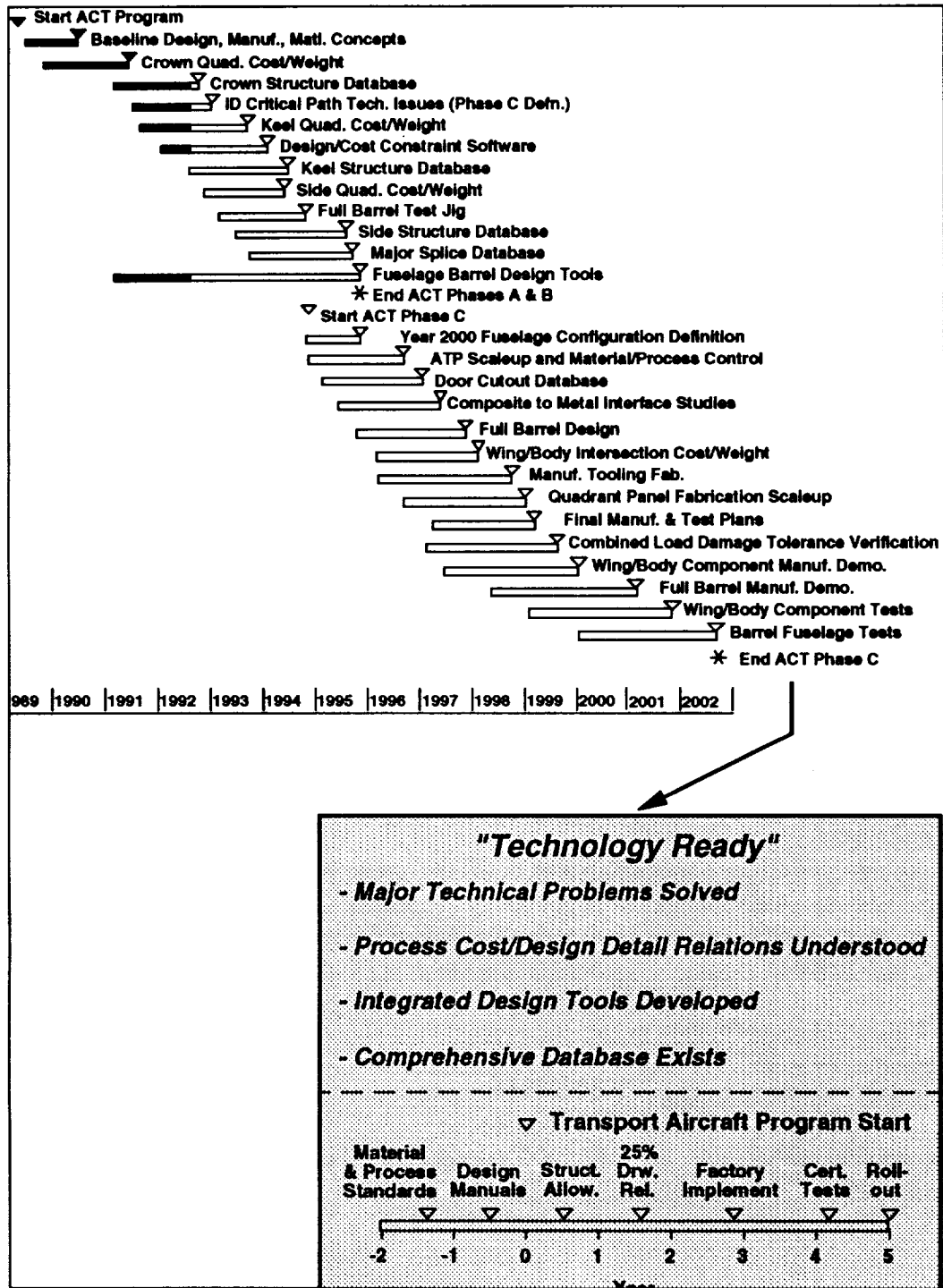

Figure 11. Critical path to composite fuselage.

The bottom of Figure 11 illustrates that the combined results of ATCAS Phases A, B, and C will yield a level of technology readiness which, if combined with Boeing internally funded efforts (e.g., other fuselage sections, material and process standards, design manuals, and structural allowables), would prepare the company for commitment to a composite fuselage application. Major technical problems will be solved during the

course of the program studies. Relationships generated between structural details and total manufacturing costs will provide future hardware designers with insight on how their decisions affect the efficiency of selected processes. These relations will be integrated into design tools that include sizing analyses and comprehensive test results, providing the composite structural database needed to make commitments to a major hardware program. The combination of ATCAS and IR&D results will allow Boeing to generate standards, manuals, and allowables which facilitate hardware design.

List of Ten Technical Issues

The overall ATCAS goal of demonstrating technology readiness will be achieved when major technical issues have been addressed in sufficient detail to provide the necessary confidence for commitment of composites to commercial transport fuselage applications. Ten items were identified as representing especially critical issues to be addressed in Phases A, B, and C. These are listed below.

- 1.) Manufacturing scale-up of configured panels
- 2.) Damage tolerance of crown, keel, and side panels
- 3.) Inspection and repair technologies for selected designs
- 4.) Load redistribution near major fuselage cutouts
- 5.) Technology developments for low-cost framing elements
- 6.) Wing-to-body intersection development program
- 7.) Structural detail/manufacturing cost relationships for selected designs and processes
- 8.) Integrity of bonded elements in configured fuselage structures
- 9.) Development of mechanical joints for major panel splices
- 10.) Metal-to-composite interfaces

A multidiscipline team of manufacturing, structures, materials, and design engineers are currently addressing these issues. All issues but number 6 are currently under study.

Discussion of Technical Issues

Manufacturing scale-up of configured panels. Manufacturing trade studies by the ATCAS DBT has suggested that large composite fuselage panels, referred to as quadrants, have potentially lower costs than aluminum technology. This relates to projected cost benefits of automated tow placement (ATP) and the assumed reduced assembly labor for bonded stiffening elements and less longitudinal splices because of the larger panel sizes (i.e., 4 instead of 10). Key manufacturing demonstrations which are needed to verify such cost savings include: (a) ATP for tailored fuselage skins, (b) panel cure tooling, (c) configured panel process trials, and (d) manufacturing tolerance control. Such technologies will be developed at a subcomponent level during Phases A and B and then scaled to full size in Phase C.

Figure 12 shows the relative size difference between panels manufactured in Phases A and B versus the larger size panels which will be fabricated during Phase C. Initial cure trials are performed at a size less than or equal to the 3 ft. by 5 ft. curved panels shown in the figure. While these small panels yield some useful information on the cure cycle and

tooling details at stiffener and frame intersections, they are not large enough to provide necessary information on manufacturing processes and tolerances. The ATCAS DBT selected 7 ft. by 10 ft., curved panels to more sufficiently evaluate whether the selected design concept and processes lend themselves to the quadrant approach to cost savings. Each panel process step is evaluated versus assumptions used in cost estimating. In addition to demonstrating processes and collecting cost data, ATCAS manufacturing trials provide panels for element and subcomponent tests.

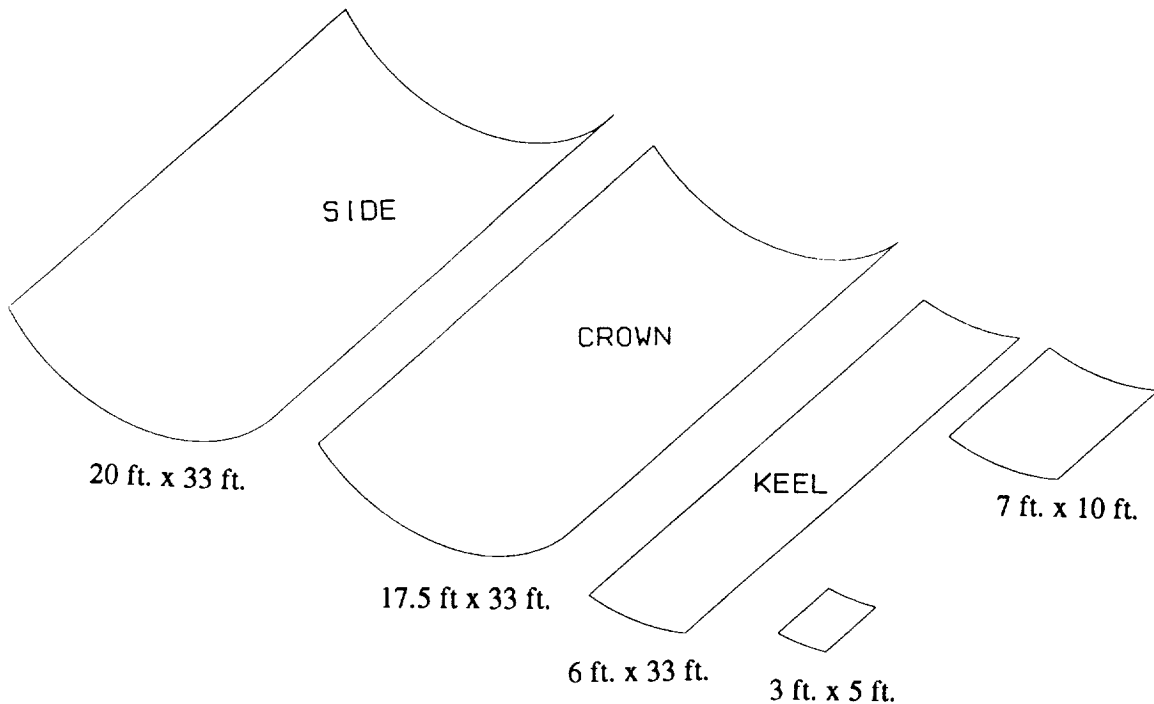

Figure 12. Large panel manufacturing demonstration.

Locational tolerance control and panel dimensional stability must be achieved to reduce the large panel assembly costs. Stiffeners and frames must be processed, machined, and aligned on the skin within tight tolerances to achieve the former, while the latter requires control of overall panel warpage and local distortion of curved design details. Advanced tooling designs are being pursued to ensure that bonded elements are located accurately on the panel. All considered baseline designs (i.e., stiffened panels with bonded stiffeners and frames and sandwich panels with bonded frames) will be sufficiently stiff following cure and; hence, it will not be possible to overcome mismatched tolerances with excessive assembly force. Costly shimming and rework would increase the assumed assembly costs, negating the advantages of large panel fabrication. Measurements taken after cure evaluate the success of each tooling concept considered in ATCAS. The manufacturing issues of overall panel warpage and local distortion (i.e., referred to as spring back) are being addressed by the DBT with the support of test measurements and structural analysis. Test measurements taken for stiffened panels have indicated that the cured panel distortion relates to temperature, local stiffener design detail, and a mismatch between skin and element coefficients of thermal expansion (ref. 8). Analysis developments which have been performed to support these tests will be applied to

constrain detailed design (e.g., element and skin laminate layups, local element geometry) and support tooling design.

Damage tolerance of crown, keel, and side panels. Damage tolerance design criteria consistent with that for current production aircraft has been adopted to ensure structural integrity for damage ranging from nonvisible defects to failed structural units. Design load requirements for the various types of damage are described on the left side of Figure 13. The "Ultimate" design requirements have considerable margin of safety over loads that the aircraft is expected to see during its lifetime. This provides conservatism in designing for a class of damage and defects that are difficult to define, analyze, and test. In practice, this condition is demonstrated for composites with barely visible impact damage or relatively small penetrations (e.g., classified nondetectable). The "Limit" design requirements are governed by larger damage sizes defined as a loss of elements (e.g., stiffener, frame, length of skin) or structural units (e.g., combined loss of stiffener and adjacent skin bay). Since limit loads can occur during the lifetime of an aircraft, requirements to consider large damage sizes promote failsafe design practices in which the damage will likely be found and repaired within inspection intervals. The final part of the damage tolerance design philosophy, continued safe flight, relates to large discrete source damage (e.g., engine failure) which occurs in flight with knowledge of the crew. Lower load conditions are used for this requirement because the crew will knowingly limit aircraft maneuvers. Note that such discrete source damage scenarios that are critical for cabin pressure are designed to limit conditions.

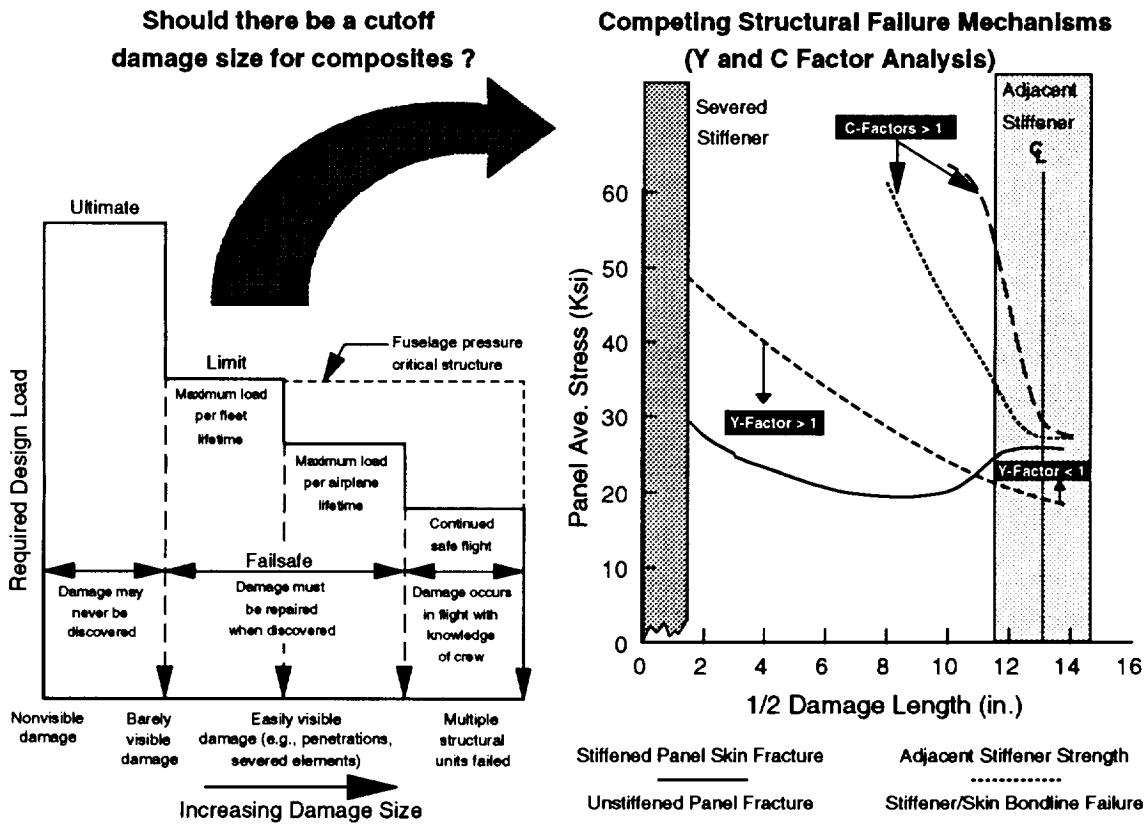

Figure 13. Damage tolerance design philosophy.

Metal fuselage structure has followed failsafe and damage tolerance design practices for some time because fatigue crack growth is a critical issue. The right side of Figure 13 illustrates that redundant structural design practices with multiple stiffening elements promote the arrestment of damage at a sufficiently large size to ensure that it is found and repaired. Note that cracked stiffened structures with severed elements allow small damage growth at lower stress levels than an unstiffened structure (due to loads redistributed to the skin from a severed element). However, larger damage growth is arrested in the former and unstable in the latter. As a result, the redundant stiffened design sacrifices the potential for greater small damage strength for overall improved damage tolerance, assuming that it is easier to find large damage and restore the structure to full capability in a timely manner.

One question often asked for composite structures is "since composites do not have fatigue crack growth problems similar to metals, should there be a cutoff damage size for limit design requirements?" Possible impact or penetration threats for a transport aircraft include (a) large foreign object impacts that occur in service (e.g., runway debris, birds, and ice), (b) maintenance accidents (e.g., tool drop and wind blown scaffolding), (c) collisions with service vehicles, (d) lightning strike, (e) sabotage, and (f) impact events due to the failure of other aircraft parts (e.g., tire burst, systems failures). These events may result in clearly visible damage that may go either unreported or undetected prior to subsequent service. Failsafe design practices for addressing metal fatigue issues have had the additional benefit of ensuring the structure is good for large impact or penetrating damage events. The ATCAS program has adopted damage tolerance design practices which enforce limit load requirements for loss of a structural unit. As discussed in the previous paragraph, the redundancy of a stiffened panel design is such that the structure is failsafe for both small and large damage sizes. This eliminates the need to define a cutoff damage size. The same cannot be said, however, for composite sandwich structures. The question of cutoff damage sizes for composite sandwich designs will be addressed by considering the largest penetrating damage sizes imposed for stiffened structures.

The schematic in Figure 13 shows residual strength analysis for a balanced design in which performance is achieved through a compromise between three competing structural failure mechanisms. The "Y-factors" shown in the figure quantify the effect of structural configuration on the shape of a base residual strength curve (i.e., unstiffened skin fracture). When Y-factors are greater than 1 (e.g., damage sizes in the shadow of the severed stiffener), damage growth will occur at stresses less than those for an unstiffened skin. When Y-factors are less than 1 (e.g., damage sizes approaching the adjacent stiffener), the opposite is true. In the case of Figure 13, structural configuration factors result in damage arrestment. In the analysis of damaged structure, C-factors quantify the effect of load redistribution on panel residual strength. The "C-factors" shown for large damage sizes in Figure 13 are greater than 1, indicating higher stress levels in the adjacent element and skin/stiffener bondline. Load redistribution into adjacent elements results in lower stresses in the damaged skin (i.e., Y-factors less than 1). If either the element or bondline stress exceeds their respective strengths, the Y-factor for skin damage growth will increase, reducing the panel residual strength.

Nonlinear elastic and plastic analyses are needed to calculate accurate configuration and load redistribution factors for metal fuselage structures. In composites, progressive damage aspects of the problem require attention. As in the case of plastic analysis for metal structures (e.g., ref. 9), an efficient method of simulating progressive damage is required to facilitate detailed structural modelling for composites. Strain softening laws which have been used for other structures consisting of heterogeneous materials (e.g., reinforced concrete) appear to have merits for composite structural analysis. Composite structures are also sensitive to impact damage and combined load conditions that include compression and shear. As a result, methods are needed to simulate damage and combined load failure events. ATCAS progress in these areas will be discussed in the last section of this paper. A large structural test database to verify fuselage damage tolerance is planned for Phase C.

Inspection and repair technologies for selected designs. An important part of composite structural design and manufacturing development is the supporting technologies that address the "ilities". These include maintainability, inspectability, and repairability. As more and more composite components are developed and integrated into transport aircraft, airlines are concerned that existing maintenance practices will need to be updated to reflect basic differences in the structure. An airline task group has been studying these issues as related to advanced composite design practices. It is this group's contention that aircraft manufacturers should address the cost of ownership during detailed design. This concern has recently been expressed to the ACT steering committee, including descriptions of design details that have caused problems with existing composite aircraft parts. Similar concerns have been expressed by Boeing sustaining groups for composite secondary structures currently in service (ref. 10).

During the last year, ATCAS detailed design efforts for fuselage structures have been coordinated with the airline task group. When addressing maintenance issues during design and concept development, it is important to realize that the structure can and will get damaged in numerous different ways. Examples of damage occurring to composite structures in service have been brought to the attention of the ATCAS DBT. Members of the airline task group have expressed a concern about specific features of proposed designs including (1) the combination of bonded frame and stiffening elements (i.e., bolted or bonded repair procedures for the bonded frame and stiffener intersection would be difficult), (2) the use of unidirectional lamina for exterior plies (prefer fabric or other form of more robust surface layers for wear resistance and mechanical fastened repairs), and (3) large quadrant panel size (repair procedures for major damage would be forced to occur without panel removal).

The airlines warned that incomplete procedures will result if a too limited number of damage scenarios are considered during inspection and repair technology development. As discussed in the last subsection, a number of different damage conditions are being considered in designing for damage tolerance. The development of suitable repair procedures and nondestructive evaluation (NDE) methods for the selected design details are under study. Examples of NDE technology under development in Phases A and B include ultrasonic procedures for intricately bonded elements, foam core sandwich panels, and an advanced flexural wave method suitable for field inspection. The development and demonstration of mechanically fastened repair procedures for large

penetrating damages that include severed bonded elements is under study for the crown. Non-autoclave bonded repairs with powder prepregs will be pursued for impact damage to keel sandwich panels. Both these efforts will be coordinated with the airlines, with an end goal of having airline maintenance personnel repair representative structural test articles. Expanded efforts in the areas of inspection and repair are planned to be accomplished during Phase C.

Load redistribution near major fuselage cutouts. Load redistribution near fuselage cutouts such as the wheel well and doors (cargo & passenger), complicate the three technical issues discussed thus far. Considerable variations in compression and shear loads exist in the keel and lower side quadrant due to wheel wells and cargo doors. Several developmental tasks for composite design, manufacturing, and performance evaluation are planned to address problems of load redistribution in these areas. Earlier discussions in this paper indicated that some composite materials are damage tolerant due to the ability to redistribute concentrated loads through localized matrix failure mechanisms. While this is a favorable trait for large damage tolerance, localized matrix failure would not be an acceptable mode for transferring flight loads around major cutouts (e.g., possible durability and dimensional stability problems would likely arise due to a lack of local stiffness). The same can be said of metal plastic deformation. As a result, skin thickness tailoring is needed in the neighborhood of major cutouts to ensure that strain levels seen in service remain below that which would cause permanent damage or deformation in the chosen material.

The keel studies have focussed on a thick laminate/sandwich "panelized design concept" in place of the discrete keel beam chords used in aluminum structure to beam loads around the wheel well and aft into the main body of the fuselage shell. Process developments are needed for curing the advanced thick skin/sandwich concept. In addition, ATP manufacturing developments such as laminate thickness tailoring (add/drop on the fly) and lamina fiber angle change are needed in this application to promote composite advantages over metals technology. Personnel from the Hercules ACT program are currently coordinating their efforts with the ATCAS DBT to develop the necessary manufacturing technologies that allow scale-up to 6 ft. by 10 ft. forward keel demonstration panels.

Material and structural details to be addressed for panel areas surrounding major cutouts include (a) the use of toughened matrix materials and higher resin contents to facilitate interlaminar shear load transfer in thickness transition regions, (b) thick laminate response to variable compression/shear load distributions, (c) impact damage resistance, (d) penetration damage tolerance of toughened matrix materials, (e) thick laminate splices, (f) panel dimensional stability, and (g) associated repair and inspection technologies. Building block tests in Phases A and B will address inplane and transverse shear load redistribution. A final curved panel having the same width as the full-scale keel panel and fixturing to simulate compression load redistribution at the forward end of Section 46 will be tested before the start of Phase C.

Global evaluation and detailed design of a passenger door cutout for the side quadrant is currently planned to occur during Phase B. Both the Lockheed ACT program and a Northrop subcontract for the design cost model will support this effort. Due to the level

of effort required, Phase B will not be able to start global/local design studies of the cargo door cutout. Development of door cutout structures including, all remaining design studies, supporting analyses, manufacturing trials, and subcomponent tests are scheduled to occur early in Phase C.

Technology developments for low-cost framing elements. Composite fabrication processes for fuselage framing elements that have relatively complex geometries need to be developed to minimize cost differences with current metal technologies. Elements which require development include circumferential frames, window frame modules, door cutout framing details (e.g., longerons, intercostals), and floor support structures. Early ATCAS trade studies selected advanced textile/resin transfer molding (RTM) processes as having potential for minimizing the cost of frame elements. The dimensional stability of elements processed from textile preforms and the RTM process was also expected to be good. The development of cost-effective fabrication methods and the associated process control is crucial to the acceptance of many textile/RTM material forms. Standard ultrasonic NDI methods used for inspecting tape laminates must be enhanced to separate defects from the higher levels of inhomogeneous textile microstructure.

In addition to process development, mechanics of materials and structural mechanics work is needed for textile materials. For example, constitutive relationships, structural scaling laws, design sizing analyses, and test databases are needed to predict mechanical performance. Since textile failure mechanisms are distinctly different than traditional laminated materials, they must be understood to support this effort. Of particular interest, is the relationship between the large microstructure, failure mechanisms, load redistribution, and structural geometry.

Significant work has been performed in ATCAS to develop braided/RTM fabrication methods for curved crown frame elements. Mechanics of materials analyses have also been developed for braided materials (ref. 11). These efforts will end with crown panel fabrication and testing tasks in 1992. All future efforts in manufacturing will be limited to design build team interactions with the Lockheed ACT program. Lockheed is planning to pursue textile technology developments for side and keel panel elements, yielding optimized framing elements to be included as part of large panel tests. In addition to RTM processes, advanced powder technologies will be evaluated by the Lockheed program.

Wing-to-body intersection development program. A Phase C study is proposed to address critical technical issues for composite structures in the wing to body intersection. Although the issues that need to be addressed are the same as those for other areas of the fuselage, structural details and loads are significantly different. In addition, very little composite work has been performed for this area of a transport aircraft. Phase C design efforts for components of the wing/body intersection will start with a comprehensive cost and weight trade study similar to the global evaluation used in prior phases (i.e., preliminary design, detailed manufacturing plans, and cost estimates for selected concepts). This would be followed by local optimization where detailed design efforts are supported by analysis, fabrication trials, and building block tests. Finally, subcomponents would be manufactured and tested to address critical process and performance issues for selected design concepts. Candidate subcomponent panels and

splice details for this study include: (a) portions of an upper wing panel, (b) sections of a keel beam box concept, (c) elements of the keel beam splice and side of body joint, (d) bulkheads and fittings, (e) portions of the pressure deck, and (f) subcomponents from body side panels.

Advanced technologies for fuselage barrel sections must consider the connection with structures in the wing/body intersection. For example, synergistic relationships exist between a fuselage barrel based on selected design concepts and the ability to develop an advanced keel beam concept in the wing to body intersection. The panelized keel quadrant concept was selected for Section 46 assuming that a keel beam box structure could be manufactured to react large compression loads near the wheel well cutouts. If a different keel beam design configuration is needed due to cost or performance issues (e.g., a design similar to traditional metal structure), the keel quadrant design in the full barrel would require changes due to different internal loads and attachment details. Such changes need to be recognized before committing to a full scale fuselage barrel demonstration. This is one example of the need to do some development work with the wing to body intersection as part of Phase C.

Structural detail/manufacturing cost relationships for selected designs and processes. Manufacturing costs are a major concern in replacing aluminum technology with composites. The ATCAS global/local design build team (DBT) approach was established to study structural detail/manufacturing cost relationships. Manufacturing technologies under development in Phases A and B are projected to have significant cost savings versus advanced aluminum construction. As discussed earlier in reference to Figures 7 and 10, the relationships between manufacturing costs and structural details must be understood prior to the start of a hardware program to constrain design characteristics to a range that ensures efficient factory flow. To achieve this goal, manufacturing studies have been directly tied to detailed design, promoting critical assessment of the capabilities of selected processes. Manufacturing trials are collecting databases to support the development of design cost analysis tools which will help constrain hardware design within a range where process cost savings are achievable.

Design analysis tools are needed to support the hardware program DBT with a timely estimate of the cost of structural details for selected manufacturing processes. Modification 13 to ATCAS will develop and verify a design cost model suitable for transport fuselage structures and composite manufacturing processes (ref. 12). The Phase A and B deliverables for this effort include:

- (a) theoretical design detail/cost relationships for fuselage structures and selected composite manufacturing processes
- (b) design analysis methods to size fuselage structural details and constrain design decisions affecting manufacturing tolerances
- (3) software for predicting design cost, performance, and weight
- (4) optimization algorithms to blend design details over variable load conditions and design requirements within cost, weight, and performance constraints
- (5) documentation of design tool usage, including results from applications and sensitivity studies.

The model will be packaged as Cost Optimization Software for Transport Aircraft Design Evaluation (COSTADE).

The COSTADE design tool will help the Phase C DBT select design details which are cost effective in fabricating a full barrel with the desired processes and tooling approaches. It will represent the manufacturing and structural databases generated during Phases A and B of the ACT program. A hardware design environment proposed for Phase C (e.g., schedule driven decision gates, long tooling lead times, simulated load changes, and interaction with planning, configuration, and systems groups) will help ATCAS evaluate the utility of COSTADE, flexibility in manufacturing tooling approach, and readiness for composite fuselage design.

Manufacturing scaleup efforts during Phase C will include a critical cost evaluation of the composite processes selected for fuselage barrel fabrication. In particular, ATP, textile/RTM, panel subassembly, curved panel cure, and other selected ATCAS processes will be studied at the detailed step level for recurring labor, machine time, scrap rate, rework, and maintenance issues. Data from these studies will help to judge cost modelling assumptions, update recommendations for future factory equipment needs, and assess the risks of a production program.

Integrity of bonded elements in configured fuselage structures. The designs for crown, keel, and side panels include cobonded frame elements. Crown panels have included cocured hat stiffening elements. Baseline side panels include cobonded window frames and stiffening elements. Manufacturing, analysis, and testing tasks are planned to support the acceptance of such structures by the industry, airlines, and FAA. To date, manufacturing trials have addressed panel subassembly, cure tooling, and autoclave cure issues associated with bonded crown panels. Tests are planned to evaluate the effects of skin postbuckling, pressure pillowing, and various damage scenarios in configured subcomponent panels.

Suitable structural test and analysis methods are needed to evaluate the residual strength and durability of composite panels with bonded elements. The ATCAS program has been performing strength and durability studies with bonded coupons and elements. Structural issues will require a larger scale of investigation. For example, element pull-off tests traditionally used for screening design concepts do not yield sufficient quantitative data to evaluate the debond growth mechanisms between stiffening elements and skin in a configured structure. Analysis and subcomponent tests that include pressure and postbuckling need to be performed to evaluate the effects of design details (e.g., intersecting elements and frame mouseholes) on the driving force for debond growth. The development of test methods which evaluate the durability of partially debonded elements contained within a configured structural arrangement are needed. The associated analysis to ensure proper load introduction into debonded elements contained in pressure boxes and other test fixtures needs to be included in the effort. Other analysis tasks include the development of design configuration (Y) and local load redistribution (C) factors for design details and combined load failure criteria for bonded joints. Sufficient efforts in collecting a database and developing structural analysis procedures will help ensure durable advanced composite designs (i.e., any debond growth is self arresting rather than unstable).

Alternate design concepts having lower risk and less development requirements have been considered. These include mechanical attachment of circumferential frames and elements that frame cutouts to skin panels with cocured stiffeners. Activities to combine bolted and bonded concepts will be pursued as well as studies of structural factors affecting debond growth and arrestment. The favored ATCAS procedure for debonded element repair includes mechanical fastening. Some process studies, analysis, and tests for alternate concepts with mechanically fastened frames will occur in Phase B to ensure the program is able to react to a change in the baseline design for Phase C. Such a change would occur if it is judged that the bonded frame technology has not matured to a level that justifies its risk in the full barrel manufacturing demonstration and test.

Development of mechanical joints for major panel splices. Mechanical attachment methods were selected as baseline for ATCAS longitudinal and circumferential fuselage splices. As discussed for the issue on manufacturing scaleup, dimensional tolerances of large, stiff quadrant panels must be closely controlled to avoid problems in panel splicing and body join. As part of the solution to this problem, innovative splice design concepts and the associated manufacturing methods which allow reasonable misalignment of stiffening elements will be pursued. Quadrant panel blending for longitudinal and circumferential panel splice details will be studied as part of local optimization design tasks for Phase B. Mechanical joint compatibility issues as related to differences between side and keel quadrant design concepts (i.e., stiffened panel and sandwich, respectively) will require special attention at the lower longitudinal splices. This is particularly true in load redistribution shadows near wheel well and cargo door cutouts. Current splice design details for quadrant panels include edge band padups in the skin. These details will be investigated as part of the Phase C manufacturing scaleup (ATP and quadrant panel fabrication).

Phases A and B efforts include the collection of coupon and element mechanical joint test data and supporting analyses for selected advanced material forms such as tow placed laminates and braided frames. The response of configured panel splices to combined load conditions, including pressure will be studied in Phases B and C of the program. Load sharing analysis methods will be developed to include the effects of nonlinear elastic and strain softening laminate behavior. These factors are expected to effect configured panel splice response under combined load conditions. The Phase B fuselage splice efforts culminate with two large longitudinal panel splice and one aft circumferential splice tests in the full-barrel pressurized test jig (Option 1 to Phase B). The Phase C activities will expand this effort, including further addressing damage tolerance and pressure containment issues.

Metal-to-composite interface. Since it is unlikely that all parts of a fuselage will be non-metallic, interface issues between metal and composite parts will need to be addressed. For actual aircraft application, solutions to interface issues may allow the use of composites for some fuselage panels or elements before composite application to an entire full barrel. For example, some fuselage parts in the wing to body intersection have sufficiently complex geometry that current metal processes have clear economic benefits over composites. Advanced hybrid fuselage structures that minimize cost and weight by utilizing the advantages of both metal and polymeric composite components could prove to be better than a structure consisting of one or the other.

As shown in Figure 11, significant time will be spent early in Phase C addressing the issues which relate to attaching composite and metal structures. This effort will include design, fabrication, analysis, and tests. Cost and weight risk analyses will identify fuselage structural components or elements which are best suited for metals. The combined effect of optimizing part cost at the expense of total assembled cost will be addressed while studying metal to composite interface issues. These issues include corrosion, durability, hygrothermal expansion mismatch, mechanical attachments, lightning strike, and electromagnetic force. The DBT will decide the specific composite to metal hardware combinations in which to perform detailed design, fabrication trials, structural analyses, and subcomponent tests.

ATCAS PROGRESS

The last overview paper written for ATCAS was presented at the First ACT Conference and highlighted progress on fuselage baseline concept selection and global evaluation of the crown quadrant (ref. 2). Crown local optimization was presented at the Second ACT Conference (ref. 3). The following discussions highlight crown manufacturing and test verification, keel local optimization progress, and plans for future work in the side quadrant and major splices. Note that the keel global evaluation is detailed in another paper presented at this conference (ref. 7).

Crown

Figure 14 reviews characteristics of the ATCAS crown quadrant. Note that the quadrant has changed from a 90⁰ to a 99⁰ segment. This increase was made based on a desire by the DBT to reduce the size of side quadrants. Any further increase in the crown quadrant size was not admissible due to issues related to the passenger emergency escape doors.

- Cocured Hat-Stiffeners and Cobonded J-Frames
- Tow Placed Skin (AS4/938, 35% RC)
- Tow Placed, Draped-Formed Stiffener (AS4/938, 35% RC)
- 2-D Braided/RTM Frame (AS4/RSL 1895, 37% RC)

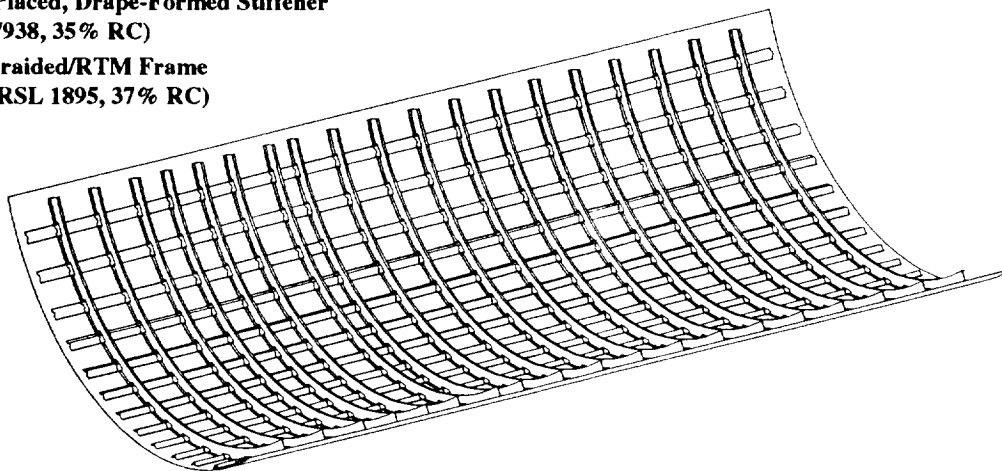

Crown Quadrant: 99⁰ Segment

Figure 14. Baseline crown design, materials, and processes.

Manufacturing Scaleup

Problems in Early Manufacturing Demonstrations. Soft tooling trials for the crown panel design were discussed at the last ACT Conference (ref. 13). These trials ended with two curved 3 ft. by 5 ft. panels that each included three cocured hat-stiffeners and three cobonded J-frames, i.e. braided frames were precured using an RTM process and then adhesively bonded during skin and stiffener cure. When the panels were inspected following the conference, hat-stiffeners were found to have some anomalies and geometric distortion. Skin and stiffener porosity and delamination were found in microscopic inspections. The latter was possibly caused by the laminated aluminum stiffener mandrels being difficult to remove after the panel was cured. Most of these problems were initially thought to be due to the segmented soft tooling approach and loss of the vacuum seal that occurred during the cure cycle.

Proceeding with the investigation, a flat 5.25 ft. by 12.5 ft. five stringer fracture panel without cobonded frames was fabricated at Hercules (ATCAS subcontract) using laminated aluminum stiffener mandrels and traditional bagging procedures instead of soft tooling. The bagging procedure worked well. Microscopy and NDE results indicated that the hat cross-sections were well controlled and the panel was free of anomalies such as porosity. Significant amounts of force and a special procedure for gripping the panel were required to remove the mandrels, causing some delaminations between the skin and stiffeners. Delaminations were repaired using mechanical fasteners and the fracture panel was successfully tested (see discussions later in this section). Past ATCAS hat-stiffened panels were fabricated using traditional bagging, coupled with silicon stiffener mandrels. Silicon mandrels for these trials were easily removed after cure but stiffeners had some fiber volume variation and angle distortion in cross-sections. Since laminated aluminum mandrels have a lower coefficient of thermal expansion (CTE) than silicon, better stiffener cross-sections were expected with the former.

Boeing ATCAS/Hercules ACT Design Build Team for Crown Panel Fabrication.

Problems that occurred with curved soft tooling trials and the flat five stringer fracture panel, led to the formation of a special DBT to obtain solutions that would not have a major impact to schedules. The goal was to complete crown manufacturing work by mid 1992 so team members could pursue keel panel developments. Most ATCAS DBT work reported in the past has involved design cost and weight trade studies. The use of small DBTs to address more specific manufacturing and structures issues is common in airplane programs. Reference 14 gives additional details on the crown processing DBT.

Figure 15 shows the DBT members, problem definition, and the recovery schedule developed for the crown panel fabrication tasks. Team members for this effort included Boeing ATCAS and Hercules ACT personnel. A problem definition and several solution paths were obtained during the first month of the DBT work. Six main solution paths were considered based on their estimated chance for success. In order to minimize risk, the two most likely paths were selected. Significant cured panel warpage noted in early crown panel fabrication (overall axial panel warpage and local transverse spring-in at stiffener locations) was included as part of the problem definition in Figure 15. This warpage was thought to relate to thermal expansion mismatches for skin and stiffener layups, stiffener cross sectional geometry, and details of stiffener tooling, e.g. thin

aluminum lamina, thin silicon sheath, and adhesive inserts web/skin flange intersection. Such issues possibly added to problems observed with cure tool removal and cross sectional anomalies (ref. 8). Therefore, some design changes were considered for all solution paths. As part of these redesign efforts, the DBT also desired to increase crown quadrant size and update crown load conditions to facilitate comparisons with advanced aluminum concepts (see discussions in an earlier section). The schedule in Figure 15 shows specific tasks that were performed to obtain a solution to the problems.

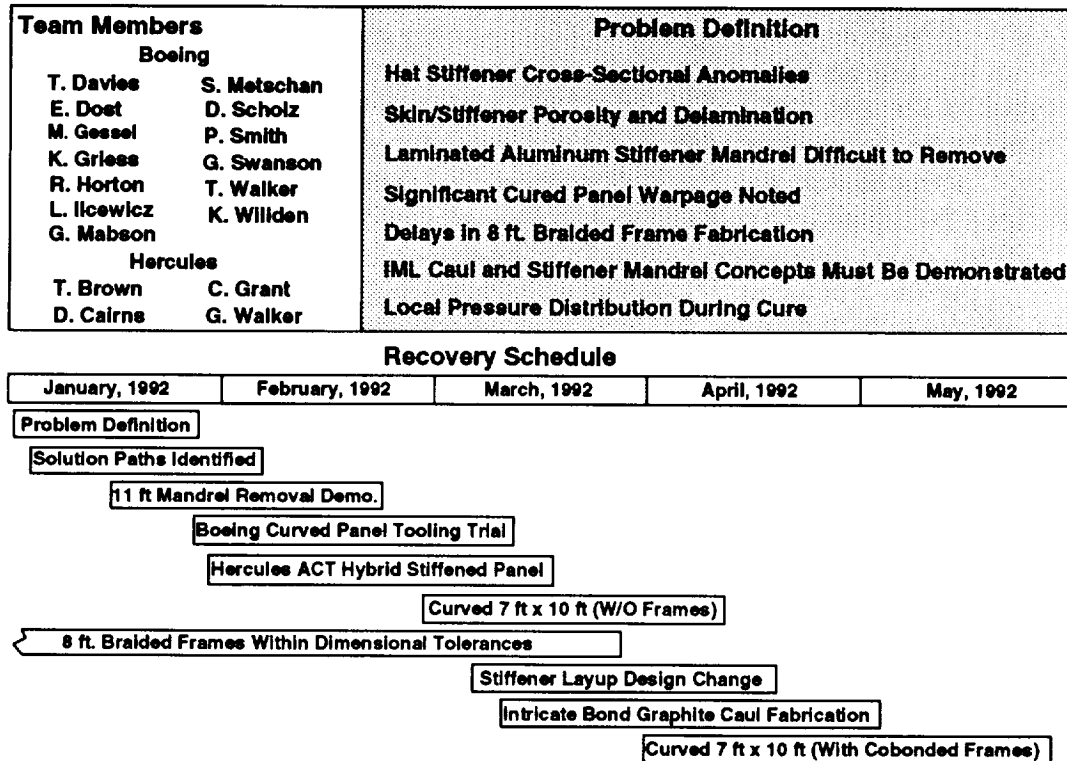

Figure 15. DBT to address crown manufacturing problems.

The solution path favored by the DBT retained the baseline design type, i.e. cocured hat-stiffeners and cobonded J-frames, but considered some changes in cure tooling and detailed redesign. Cure tooling for this option utilized silicon stiffener mandrels and advanced IML cauls. The latter was scheduled to be developed and demonstrated for curved panels over a two month period. The most attractive candidate for the IML caul included a combination of soft tooling at frame locations and segmented graphite cauls, e.g. thin precured fabric, for skin and stiffener areas between frames. Risks for this solution path related to cure tooling development and dimensional tolerance control for braided frames. Curved braided frame manufacturing development was taking considerably longer than expected due to tooling fabrication problems. As a result, braiding and RTM process step scaleup to the 8 ft. size had not yet provided dimensional tolerance data necessary to evaluate whether frames could be cobonded during the panel cure step. As shown in Figure 15, this data was expected by the end of March.

The alternate solution path involved changing to a Family B design concept, i.e. cocured hat-stiffeners and mechanically fastened J-frames, that had significantly less risk. This

concept was developed in parallel with the first solution path and many scheduled tasks supported both. Tooling developments for the Family B concept had significantly less risk for the allotted schedule. The large scale panel fabrication schedule for this concept also had little risk associated with delays in 8 ft. braided frame processes because the frames were not needed until panels were cured. In addition, manufacturing tolerances for a bolted frame concept were thought to be less than those needed for cobonding.

Cure tool developments. The first fabrication task supported both solution paths by demonstrating a skin/stiffener IML tooling approach and the ability to remove silicon mandrels from hat-stiffeners (i.e., "11-ft. mandrel removal demonstration" in Figure 15). The panel used for this task had the baseline skin layup and two stiffeners, one with a layup identical to the skin and the other representative of the original baseline design. Hand laid tape laminates were used for both stiffeners and skin. Three IML cure tooling approaches (two IML caul plate concepts and traditional bagging) were used in three different segments along the length of the panel. The two caul plates were precured graphite fabric (4 plies between stiffeners for flexibility during panel subassembly and 10 plies at the stiffener to help form the hat shape during cure). These cauls were precured on a male metal tool mockup of the panel's IML surface. Following panel cure, no problems were noted in removing the silicon mandrels. Stiffener cross-sections in areas that utilized the graphite cauls were well controlled. Cured panel warpage in the axial direction was distinct on the side with mismatched skin and stiffener layup, and significantly less on the other side. A photograph of the side with greater axial warpage is shown in Figure 16. Upon cutting the panel down the centerline to produce two 10 ft. one-stiffener panels, warpage was seen to increase for the side with mismatched skin and stiffener layup, while the matched side was found to have negligible axial warpage.



Figure 16. Tool development manufacturing trial for a 11 ft. long hat-stiffened panel.

Referring back to Figure 15, the scheduled task entitled "Boeing curved panel tooling trial", directly supported the first solution path. The flexible IML graphite caul concept, which produced good stiffener cross-sections for the flat panel in Figure 16, was modified to allow cobonded frames, characteristic of the baseline design. This tooling

redesign yielded a hybrid consisting of: (a) segmented graphite reinforced cauls for stiffened panel regions between frames, (b) soft tooling at frame intersections, and (c) mouse hole plugs to facilitate stiffener cure at the frame intersection. The modified tooling was successfully demonstrated at Boeing for a 3 ft. by 5 ft., curved, Family C panel with three cocured stiffeners and three cobonded frames. This trial fabrication utilized a 76 in. radius Boeing cure tool, compression molded fabric frames available for this geometry, and tape material for skin and stiffener laminates. With successful completion of this task, the main issue limiting the fabrication of a 7 ft by 10 ft Family C design was delays in the development of braided/RTM frames of acceptable dimensional tolerances for cobonding. A solution to this issue will be discussed later.

Manufacturing demonstration for the second solution path. Major tasks that supported the second solution path included fabrication of two large Family B panels, one flat and the other curved. The flat panel, referred to as the "Hercules ACT hybrid stiffened panel" in the recovery schedule, is shown in Figure 17. This panel was fabricated for the Hercules ACT contract number NAS1-18887 (ref. 15) and tested for axial damage tolerance by ATCAS. Silicon stiffener mandrels were easily removed from the cured panel and stiffener cross sections had no anomalies.

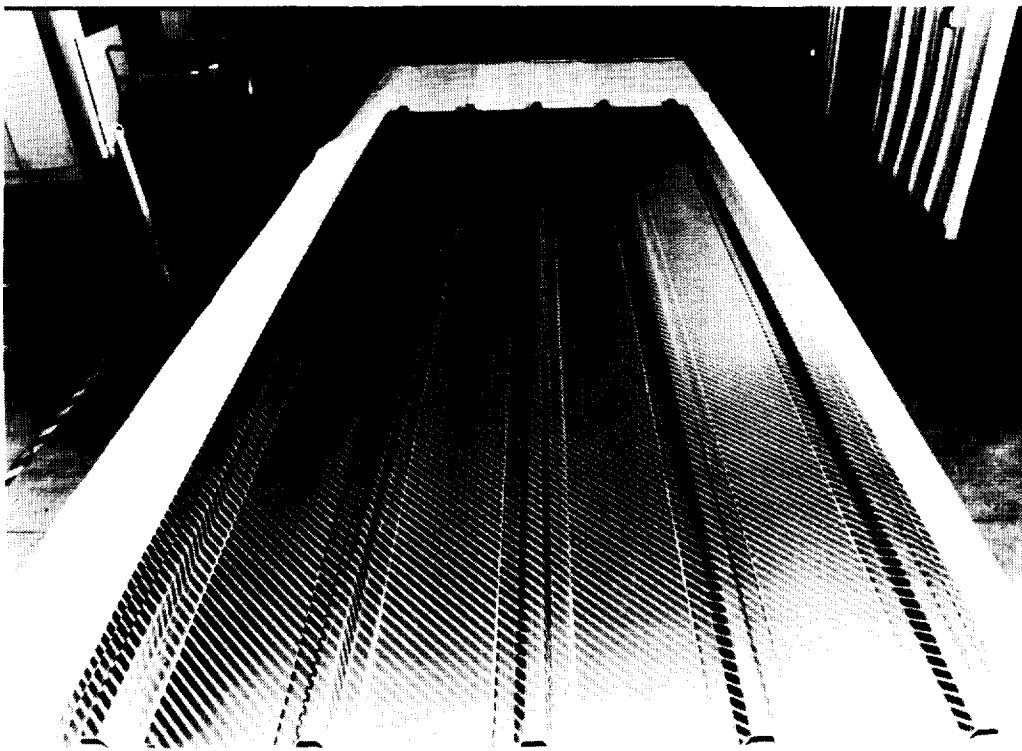

Figure 17. ATP intraply hybrid damage tolerance panel (63 in. by 150 in.) cured using a flexible graphite IML caul.

Figure 18 shows a curved (122 in. radius), 7 ft. by 10 ft. panel, successfully fabricated at Hercules under subcontract to ATCAS. This panel consisted of AS4/938 tow-placed skin and stiffeners. Panels in Figures 17 and 18 both used the same cure tooling, i.e. precured flexible graphite cauls and silicon stiffener mandrels. Since frames were not cobonded,

the IML caul was continuous for each panel. As was the case for the large flat hybrid panel, stiffener mandrels were easily removed and no stiffener cross sectional thickness anomalies were noted. Manufacturing trials that culminated in panels shown in Figures 17 and 18 successfully completed tasks for the second solution path, ensuring ATCAS had a backup position in the event that the cobonded frame concept was unable to scale to the 7 ft. by 10 ft. panel size. Additional manufacturing and test data comparing Family B and C concepts also enhance the DBT database supporting future design decisions (e.g., quadrant panels for Phase C).



Figure 18. Family B crown quadrant manufacturing demonstration.

Both panels for Family B manufacturing demonstration had skin and stiffener layups from the original locally optimized design (ref. 3). As was the case for other fabrication trials with this design, panels were found to have significant axial warpage and transverse spring-in at each stiffener location. The effect of these manufacturing tolerances on the mechanical attachment of braided frames for the curved panel in Figure 18 will be addressed during the summer of 1992. Assembly issues for major panel splices will also be assessed based on measurements and analysis of panel warpage and local stiffener distortion (see methods described in ref. 8).

Braided/RTM Circumferential Frames. The scaleup of frame manufacturing processes occurred at Fiber Innovations as a collaborative effort with the ATCAS DBT. This task culminated with the fabrication of curved, 8 ft., J-frames for use with the 7 ft. by 10 ft. crown panel manufacturing demonstrations. Braided/RTM batch process developments

are discussed in references 13 and 14. Figure 19 shows one of the processing steps and the finished frames. Although braided frame manufacturing development caused significant schedule delays, the 8 ft. curved frames were of excellent quality. Tolerances measured for the cured frames were within limits that the DBT had set for pursuing the Family C scaleup. Several batches of frames were manufactured, allowing detailed cost studies on the process steps and their relationships with frame design details. Results are presented in another paper for this conference (ref. 16).

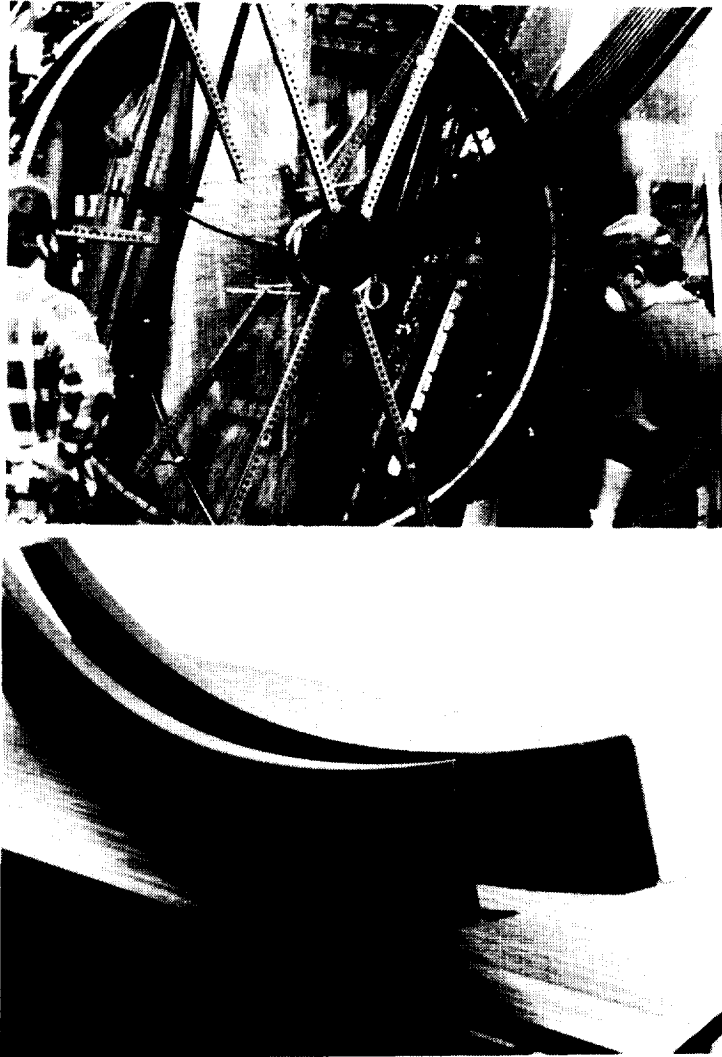

Figure 19. Braided technology scale-up; braiding on RTM cure mandrel (top) and machined 8 ft. frames (bottom).

Crown redesign. Tooling and process developments were successfully completed to solve six of the seven issues defining crown manufacturing problems in Figure 15. The last issue, "significant cured panel warpage", related to the original locally optimized

design. Crown quadrant redesign was performed with the help of the design cost model, COSTADE, over a period of five weeks. The problem description, design constraints, and resulting redesign appears in Figure 20. New constraints for minimizing panel warpage and transverse Poisson ratio mismatch were added to those used for the original design (ref. 3). In addition, aft skin layup and frame geometry were held constant due to commitments to a tension fracture database and process tools, respectively. Utilization of COSTADE to quickly obtain the design cost analyses for problems with imposed constraints is similar to what might be expected of a DBT in hardware applications.

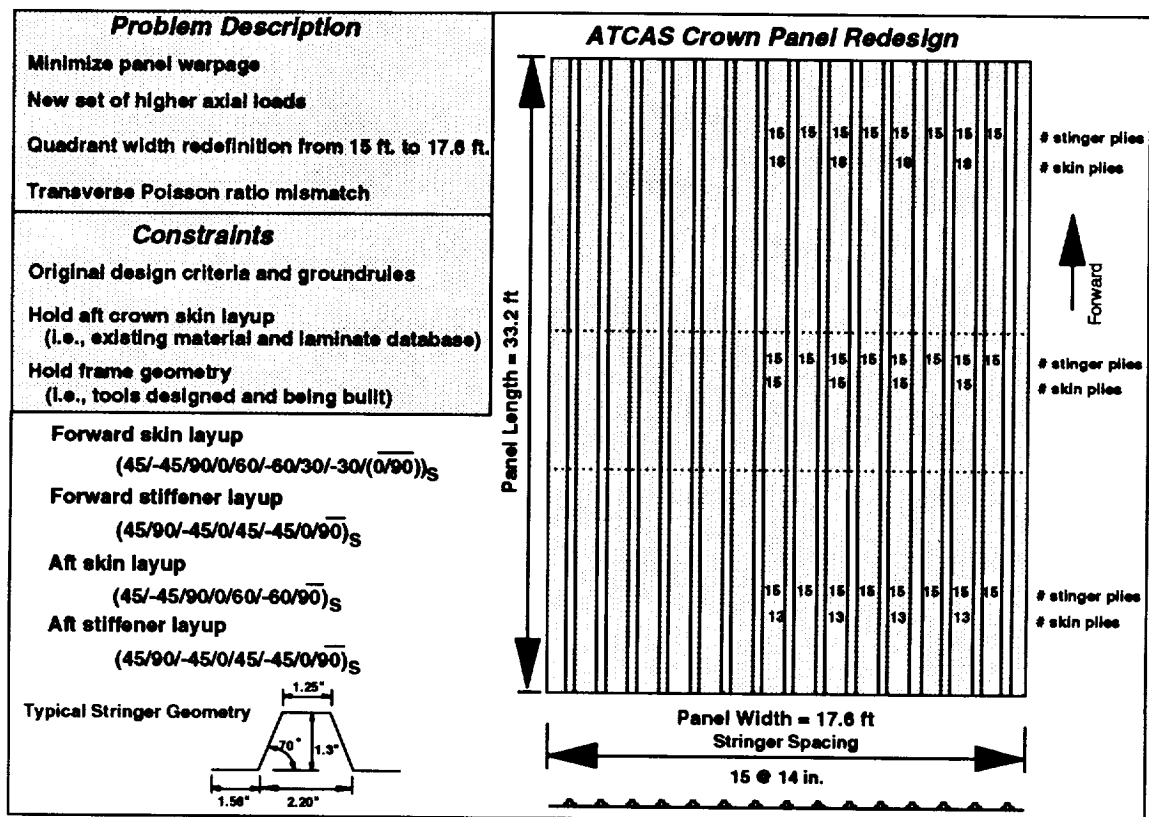

Figure 20. Application of COSTADE for crown redesign.

The COSTADE software was found to be useful in minimizing cost and weight. Several changes from the original locally optimized crown design are evident in Figure 20. Total crown panel cost and weight increased in order to meet higher axial load requirements and larger quadrant size. Some of the weight increase and associated cost related to new constraints which limited skin and stiffener layup mismatch. These increases are directly tied to a desire to reduce assembly risk, e.g. warpage. Changes relative to aluminum technology were discussed earlier. The stringer layup was significantly softer than that of the original composite design in order to meet warpage and transverse Poisson ratio constraints. Stringer spacing was uniformly held at 14 in., rather than the original design layout for increased spacing approaching side quadrants. Skin gage increased in the forward end due to higher axial loads and decreased stiffening ratio. Discussions on the damage tolerance trade between the original and current design will appear at a later date.

Final scaleup of Family C design concept. Figure 21 shows the end product of work performed by the special DBT to obtain timely solutions to manufacturing problems encountered with the baseline crown concept. In summary, several tasks gave the DBT confidence to pursue this curved, 7 ft. by 10 ft., Family C concept with six cocured stiffeners and five cobonded frames. Fabrication trials for a curved, 3 ft. by 5 ft. panel helped develop IML cure tooling that eliminated stiffener cross-sectional anomalies and mandrel removal problems. Successful completion of this task initiated the fabrication of segmented IML caul plates to fabricate the panel in Figure 21. Braided/RTM process scaleup resulted in 8 ft. braided frames with dimensional tolerance control deemed acceptable for cobonding. Five of the frames were cobonded to the panel in Figure 21. Finally, a cost competitive redesign was obtained with the help of COSTADE, eliminating some of the risk associated with assembling large, stiff, Family C concepts. The panel in Figure 21 reflects the updated crown design in an aft location.



Figure 21. Family C crown quadrant manufacturing demonstration.

Structural Development

Several design drivers for the crown quadrant combine to control minimum skin gage, stiffener spacing, skin and stiffener layups, skin splice padups, and frame attachment details. References 1 and 3 describe technical issues and design sizing exercises for this quadrant. As discussed earlier, axial and hoop tension dominate the loads in the crown. The associated failsafe damage tolerance requirements affect many design details. Some

compression axial loads from reversed body bending and shear loads approaching the side quadrant pose additional requirements for stability and bonded element performance. In ATCAS, tests and analyses efforts are coupled with the manufacturing developments in attempts to understand process induced performance characteristics.

Impact damage to minimum gage fuselage panels. All fuselage quadrants have technical issues related to impact. The minimum skin gage allowed in crown design relates to both failsafe issues (tensile residual strength after massive impact damage that penetrates a structural unit) and hail impact requirements (no visible damage and "Ultimate" load carrying capability). Since 1990, ATCAS has pursued an understanding of the impact damage resistance of composite fuselage structures (ref. 2). The designed experiment described in reference 17 included thirty-two different panels, each with three stiffeners. This experiment was performed to characterize relationships between impact events and fuselage design variables (material, laminate, and structural). Variables for the former included different impactor shapes and impact test events, e.g. low mass/high energy. Critical crown design variables included resin type, resin content, fiber type, stiffener spacing, hat stiffener geometry, and minimum skin gage. Figure 22 shows one example of crown variable combinations from the designed experiment. Hail impact simulation, i.e. 500 in lb impact by 2.5 in. diameter lead ball, was of special interest to the crown.

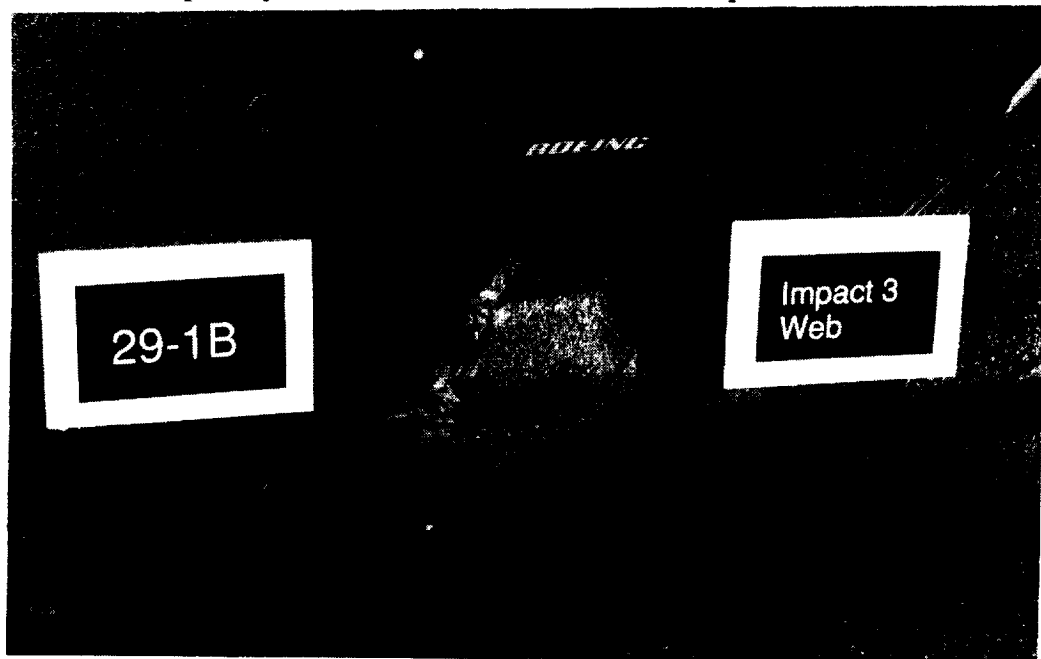

Figure 22. Hat stiffener web of a minimum gage panel consisting of AS4/977-2 (35% RC) ATP material, damaged by high energy impact from a blunt object.

Impact experiments helped to confirm crown baseline design selections. In reference 17, minimum gage hail requirements for tough and brittle matrix materials were found to be similar, i.e. hail impact visibility for thin gage skins appeared to be controlled by fiber failure. Lower resin contents were also found to be better based on similar rationale. As a result, the choice of untoughened matrix and 35% resin content were justified for the crown. The use of high performance fibers appeared to have some effect; however,

crowd cost/weight trades resulted in the selection of the lower modulus graphite fiber (ref. 1). After accounting for other design drivers, e.g. failsafe damage tolerance, crown skin gages were sufficiently thick to pass hail requirements. Structural impact tests performed near stiffeners yielded additional insights on design details such as the use of adhesive layers for cocured hat-stiffened panels (see ref. 18, which is part of the current proceedings).

Maintenance personnel desire simple inspection methods capable of determining the extent of impact damage they find and its effect on structural performance. Depending on the variables of an impact event, the ensuing damage to a composite laminate can take numerous forms. Reduction in structural performance relates to damage details which may be difficult to quantify without the help of destructive tests. A combination of tests and analyses reported in the past have successfully quantified structural residual strength as a function of damage occurring from specific impact events (e.g., ref. 19). Such an approach can be used to promote damage tolerant design; however, it has limited use in assessing the need for repair, i.e. there is generally no information on the impact event for damage found in service. A low frequency, ultrasonic, Lamb wave method has been used in ATCAS for quantifying the various damage states created in structural impact experiments. As in the case of pulse-echo ultrasound, the Lamb wave method is useful for single sided access. This method is based on relationships between flexural wave dispersion and laminate bending stiffness (ref. 20). Figure 23 shows typical results of dispersion experiments and calculated values for laminate bending stiffness.

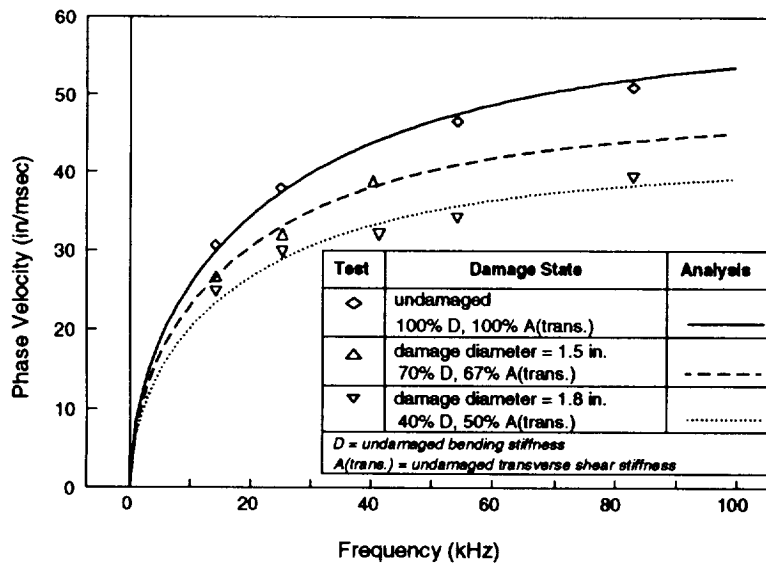

Figure 23. Nondestructive evaluation of impact damage using lamb wave dispersion experiments.

In the case of undamaged laminates (i.e., top curve in Figure 23), theory and test data agree well. Lamb wave inspection data collected over impact damage was used to back-calculate reduced bending stiffnesses for the other two curves. As discussed in reference 18, Lamb wave inspection data was found to have better correlation with a mechanical measurement of the impact damage response than traditional methods, e.g.

ultrasonic c-scan data on damage size or dent depth measurements. Future tests and analysis are scheduled to judge if the Lamb wave method is suitable for quantifying the effects of impact damage on structural response. The method will be used to quantify impact damage prior to residual strength tests. Measured reduced stiffnesses for impact damage will be used to quantify these zones in structural analysis models. Continued work in this area will help to develop tools suitable for aircraft maintenance.

Building block tests and analysis. All major subcomponent tests used to verify the crown concept have supporting tests and analyses that address behavior at the element level. For example, individual stiffening elements and large unstiffened fracture panels are used to quantify local buckling/crippling and skin fracture, respectively. These "building blocks" help to quantify individual laminate and element behavior at a dimensional scale sufficiently large enough to support structural analysis. Such an approach is also conventionally used to support the design of metallic structures due to size effects not evident in small coupons. Numerous competing failure mechanisms at the structural scale require several building block tests and associated analyses.

A large tension fracture database was collected in ATCAS for several laminates of interest in crown studies (refer back to discussions on Figures 8 and 9). The fracture data was used to quantify skin fracture behavior. This database and the need to evaluate tension fracture using large notch tests and panels of sufficient size is discussed further in reference 5. Currently, the most promising analysis for scaling tension fracture data from coupons for use in structural models appear to be strain softening laws (ref. 21).

Several tests that quantify bonded element performance, i.e. cocured hat stiffeners and cobonded J-frames, are under development. A shear lag specimen is being developed to evaluate load transfer between skin and stiffening elements. Results to date indicate long shear lag distances are required for transferring load from the skin into the stiffener cap and suggest a need to include nonlinear material behavior for the adhesive joint. These studies support analysis and test of tension residual strength for configured structure with failsafe damage conditions. Element pulloff tests are also being developed to support compression panel stability studies. Tests have successfully applied buckling mode patterns to the element, yielding data on the skin/stiffener bondline strength.

Frame/skin pulloff tests and analyses are being performed under subcontract at Drexel University. Bonded joint fracture properties have also been collected for various adherend combinations of the braided frame flange and ATP skin laminate. The original frame/skin pulloff test fixture and specimen are being redesigned to account for width and skin curvature effects. Analysis is being performed to quantify pressure pillowing in the current crown design. Results from the analysis will be used to either extrapolate test results or to change the fixture for a more accurate simulation of pressure load reactions. Results from the Drexel work will support configured panel tests in the pressure box.

Plans for compression panel tests. Several compression panel tests will occur later this year to demonstrate crown stability performance. Each test article will be machined from a curved, 7 ft. by 10 ft. crown manufacturing demonstration panel. Building block tests supporting this effort include crippling elements and stability pulloff. Nonlinear finite element analysis will be used to simulate each compression panel test. A total of

three panel crippling tests will be performed using aft crown subcomponents that have three stringers and two frames. Two of the test panels will have bonded frames and the third will have mechanically attached frames. Another compression test will evaluate wide-column buckling for a subcomponent panel having the forward crown design detail. This test article will consist of five stringers and four cobonded frames. Several impact damage scenarios are being considered for compression panel tests based on structural impact resistance results from the designed experiment. The nonlinear analyses will be used to locate impact damage in a critical stress location. Failsafe damage conditions will be considered for one of the load runs with the wide column buckling panel.

Damage Tolerance

Axial damage tolerance tests. Axial damage tolerance was evaluated using flat, five-stringer panels. Failsafe damage conditions for these tension fracture tests included a 14 in. skin penetration that severed a central stringer (simulated by a saw cut). Figure 24 shows a panel mounted in the test machine. Over 100 strain gages were used to help map damage growth and load redistribution. The test was stopped periodically, after incremental load increases, to determine the amount and type of damage growth prior to failure. NDE data collected between load steps included X-ray, pulse-echo ultrasound, and Lamb wave dispersion. Moire' out-of-plane displacement data was collected above and below the severed central stiffener. In addition, video cameras filmed tests during load sequences. This included high speed photography to capture final failure.

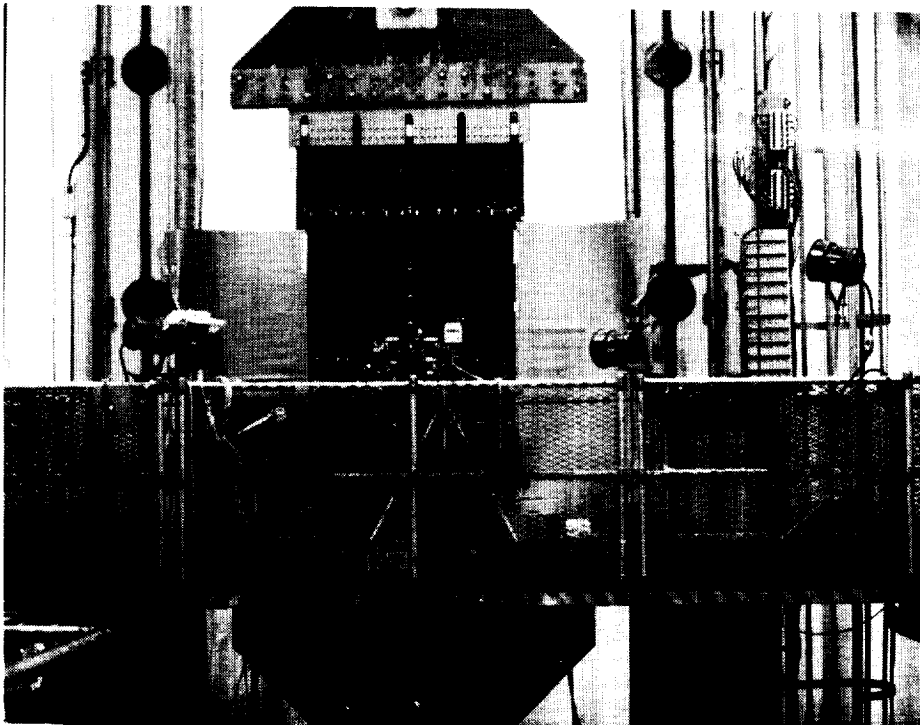

Figure 24. Axial damage tolerance test of initial ATCAS fuselage crown panel design.

Two panels were tested, one consisting of the baseline crown material, i.e. ATP AS4/938 laminates, and the other using an ATP intraply hybrid (75% AS4/25% S2/938). These panels each had the original locally optimized forward crown skin and stiffener layout. Processing of both the panels was discussed in the subsection on "Manufacturing Scaleup" (note that the hybrid is pictured in Figure 17). Hat cure mandrel removal problems occurring with the all graphite/epoxy panel caused localized skin/stiffener delamination. The delaminations were repaired using mechanical fasteners prior to test.

Axial damage tolerance analysis. Residual strength analysis for metallic structures has had to account for competing failure mechanisms and nonlinear material behavior in order to accurately predict panel failures observed in test (ref. 9). Figure 25 shows the analysis and test for a tension panel loaded to failure. The skin half crack length for this static load test started at about seven inches. Elastic and plastic predictions of three competing failure modes are shown in the figure. Note that skin fracture is temporarily arrested, at the expense of higher stresses in the adjacent stiffener and rivets that attach the stiffener to the skin, i.e. panel stresses causing stiffener or rivet failure drop with increasing crack size.

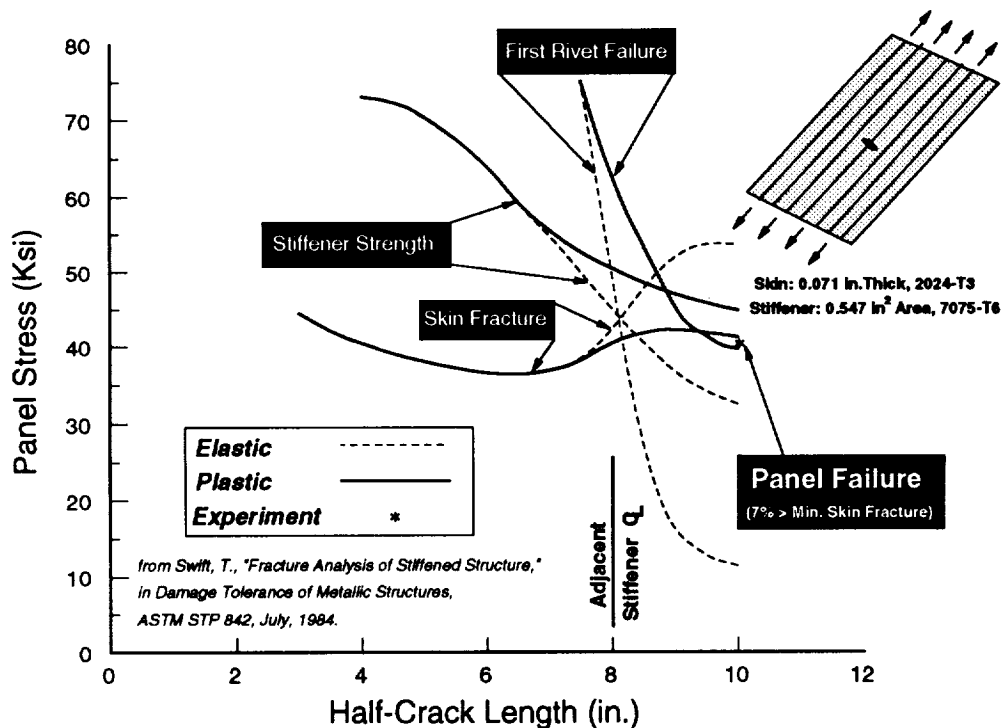

Figure 25. Structural damage tolerance of metallic panel with skin cut and severed stiffener.

Figure 25 shows that as skin damage approaches the adjacent stiffener centerline, elastic and plastic analyses deviate. Plastic analyses are shown to best predict the panel failure observed in the test. The plastic deformation of fasteners is critical to the load transfer between skin and stiffener. As the rivets yield, less load goes to the stiffener, lowering skin fracture strength. The final sequence of failure for the test panel modeled in Figure 25 was triggered by fasteners unzipping along the axis of the panel as predicted by

analyses. Note that the panel failure stress was approximately 7% greater than the lowest part of the skin fracture curve. Plastic behavior effectively compromises the three failure mechanisms, resulting in an optimum strength for the metal panel design in Figure 25.

Figure 26 shows the skin and stiffener layups for the two axial damage tolerance tests. Nearly identical failure mechanisms were observed for both panels, suggesting a relationship with design parameters held constant, e.g. skin laminate stacking sequence. Asymmetrical damage developed at the original notch tips of both panels and grew in a similar manner toward adjacent stiffeners, i.e. damage growth observed from the stiffened side of the panel was above and below the notch for left and right sides, respectively. This asymmetry was also evident in the final failure event, with broken panels skewing to the right. High speed photography taken for each panel indicated that skin damage progressed dynamically from underneath arresting stiffeners and into adjacent skin bays at maximum load. Catastrophic skin damage growth appeared to happen before skin/stiffener separation.

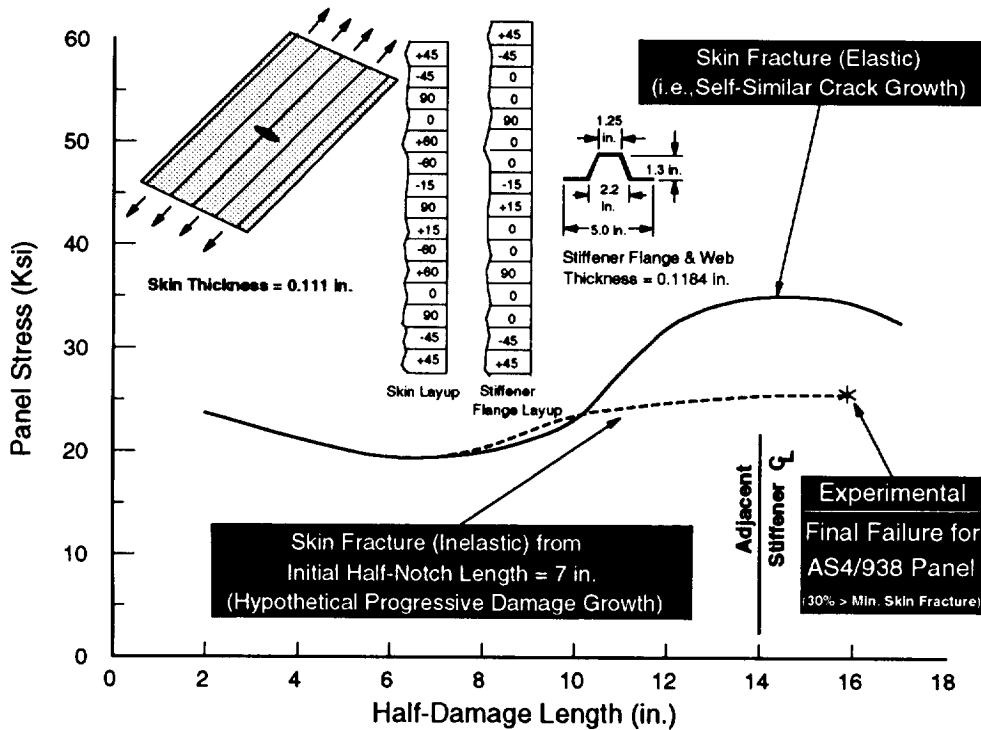

Figure 26. Structural damage tolerance of AS4/938 ATP composite panel with skin cut and severed stiffener.

Several different elastic skin fracture analyses were performed for each panel. These ranged from finite element models of panel design details to existing fracture analysis handbook methods. In each case, skin fracture properties and panel design parameters were used to make predictions of "self-similar" crack growth. A typical elastic prediction for the all graphite/epoxy panel appears in Figure 26. Note that skin fracture is predicted to be stable between half-damage lengths of 7 in. and 14 in. In a manner similar to stiffened metallic structures, the experimental skin damage growth for both composite panels was observed to be stable, arresting at the adjacent stiffeners before

catastrophic fracture. Final failure measured for the all graphite/epoxy panel was 284 kips. As in the case of the stiffened metallic panel in Figure 25, elastic methods overpredicted composite panel failure. The same relative trends appear when plotting analysis and test results for the hybrid fracture panel which failed at 356 kips.

Hypothetical analysis illustrating stable progressive damage growth observed in the all graphite/epoxy panel test is also shown in Figure 26. As discussed earlier, the composite design used for both panels had a large difference in axial skin and stiffener properties. The relatively soft skin and hard stiffener combination resulted in a panel failure stresses that appeared to be 30% greater than the minimum point in the skin fracture curves. This compares to the 7% increase for a metallic structure in Figure 25. However, experimental detection of a minimum point in the composite curve was somewhat arbitrary, i.e. notch tip damage growing to a size larger than observed in unstiffened panels.

In the absence of methods for simulating progressive damage growth in a composite structure, an analysis procedure was inferred based on observations from the first test, i.e. all graphite/epoxy panel. The method assumed panel failure at a far field strain equivalent to that required for skin fracture with a full two bay notch (Y-factor = 1 for a damage length = 2 x stiffener spacing). Important parameters for this residual strength analysis are the skin fracture properties, skin stiffness, stiffener spacing, and stiffening ratio. Figure 27 shows predictions using this method. All designs in the figure used the same stiffener spacing (14 in.) and identical layups for skin and stiffener. These layups are listed in Figure 26. The designs labeled #1 and #2 in Figure 27 correspond to the ATCAS axial damage tolerance panels. The analysis was found to accurately predict the final failure of both panels (to within 2%). The predicted difference between these designs correlates directly with changes in the effective skin fracture toughness for large notches. As discussed earlier, the hybrid skin has approximately 25% higher effective fracture toughness (see "Crown A" points in Figure 9). The additional increase predicted for hybrid design #3 relates to the increased stiffening ratio of using 100% AS4/938 material for stiffeners.

The original loads and axial damage tolerance requirements shown in Figure 27 were easily met by both designs #1 and #2. Hybrid skin designs #2 and #3 also appear to meet the new loads and failsafe constraints without any changes. The increased loads and more stringent failsafe requirements tended to drive non-hybrid designs, particularly at the forward end of the crown quadrant. In addition, redesign of the composite crown panel to help solve manufacturing problems has lead to skin and stiffener layups with more closely matched CTEs (see discussion related to Figure 20). Crown panel weight has tended to increase with the updated loads and constraints. The processability and damage tolerance of different crown designs are currently being studied under other NASA-funded work at Boeing (task contract NAS1-19349). These include the current crown design, hybrid skin designs, and variations on skin/stiffener layup mismatch.

Manufacturing induced performance for advanced material forms. A comparison of designs #1 and #4 in Figure 27 indicates that panel damage tolerance is strongly related to the fabrication process. Predictions in the figure suggest that large cost and weight penalties would be incurred if crown panel skins were tape rather than ATP laminates.

Differences relate to effective skin fracture toughness properties for tow and tape designs. Test measurements from references 4 and 5 showed that the tape material form had lower fracture properties than equivalent constituents and laminates processed using ATP. Several hypotheses currently exist to explain observed differences. Patterns of laps and gaps that occur in a laminate due to ATP processing may lead to a level of repeatable inhomogeneity that is larger than the fiber/matrix scale commonly considered for composites. This microstructure can affect the laminates' mechanical response to stress concentrations in several ways (ref. 22). Additional analysis model developments are needed to quantify unique characteristics of ATP material forms.

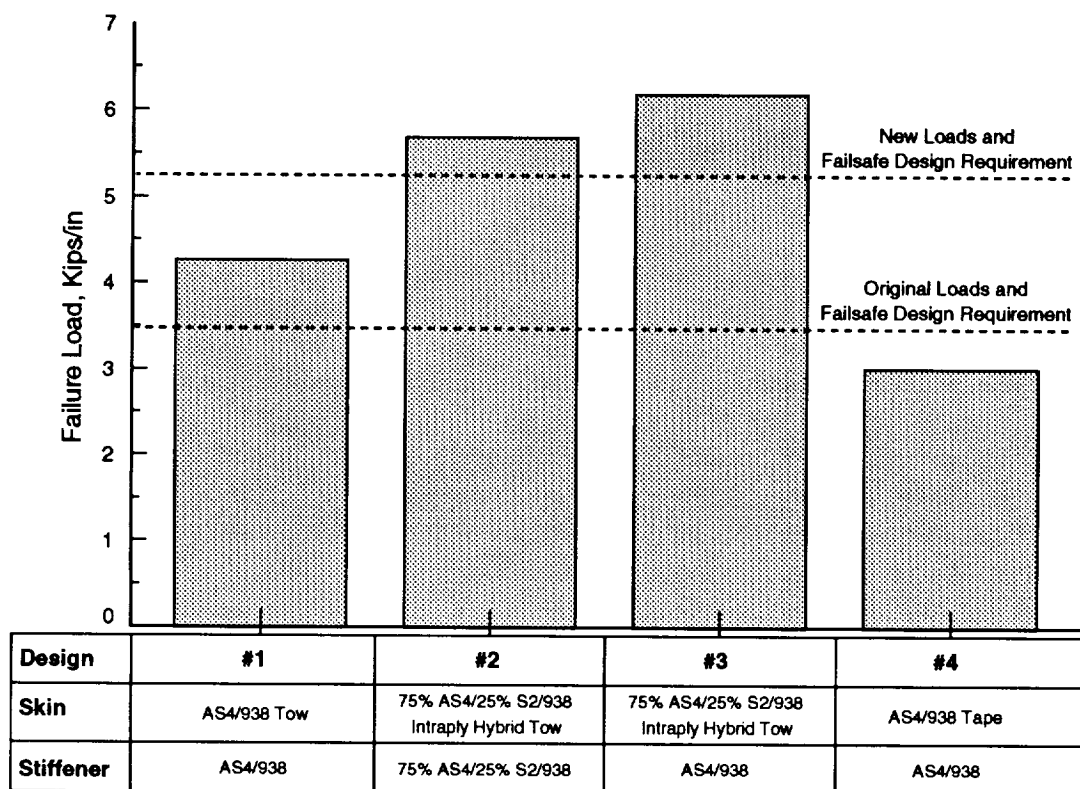

Figure 27. Analysis predictions of the effect of material types on tension residual strength for configured panels.

The laps and gaps formed in an ATP process are expected to depend on material type, machine settings, and other process variables. Manufacturing characteristics that affect structural performance must be understood in a way that promotes process and quality control. Performance advantages due to ATP were not fully recognized until the scale of mechanical testing was increased. This was particularly true of intraply hybrid ATP laminates. Nondestructive inspection (NDI) methods are needed to control advanced materials and processes because large scale testing is not economically feasible.

Similar arguments to those used for ATP laminates can be given for braided/RTM parts considered for fuselage framing elements. In each case, microstructural characteristics that affect performance must be controlled in processed structures. The goal is not to eliminate characteristic features of the microstructure, but rather to control the process

such that structural performance is repeatable from part to part. Characteristic microstructure must be distinguished from damage and manufacturing defects.

Several ultrasonic methods may be suitable for monitoring the higher levels of microstructure found with advanced processes and material forms. Ultrasonic NDI using 5 Mhz equipment with enhanced resolution has revealed unique characteristics in the microstructure of ATP panels and braided/RTM frames. Ultrasonic amplitude scans of ATP skin panels were found to have a geodesic pattern that may quantify lap and gap characteristics by detecting point to point variations in laminate density. Unique characteristics of several intraply ATP hybrid microstructures were noted during pulse-echo scans of penetrating impact damage. Differences between impact damage and repeatable microstructure were also evident in the NDI data. Local fiber volume variation in the webs of braided/RTM J-frames was discernible in ultrasonic scans. Lamb wave dispersion experiments taken over varying distances also indicated a possible relationship between flexural wave speed and higher levels of microstructure present in braided plates and intraply hybrid laminate panels.

Pressure test box development. A test box for damage tolerance testing of curved, stiffened fuselage panels loaded in biaxial tension is being developed in coordination with the Structural Mechanics Division of NASA Langley. Figure 28 shows a design pictorial of the test box and control systems. The test box will simulate various combined axial tension and internal pressure load conditions. Subcomponent crown panels that include four stiffeners and three frames fit the test section (63 in. by 72 in.). A total of nine panels will be tested in this fixture to support the ATCAS crown design. To date, the test box has been fabricated and initial loading trials were performed using the first test panel, i.e. a curved, unstiffened skin panel with tear straps.

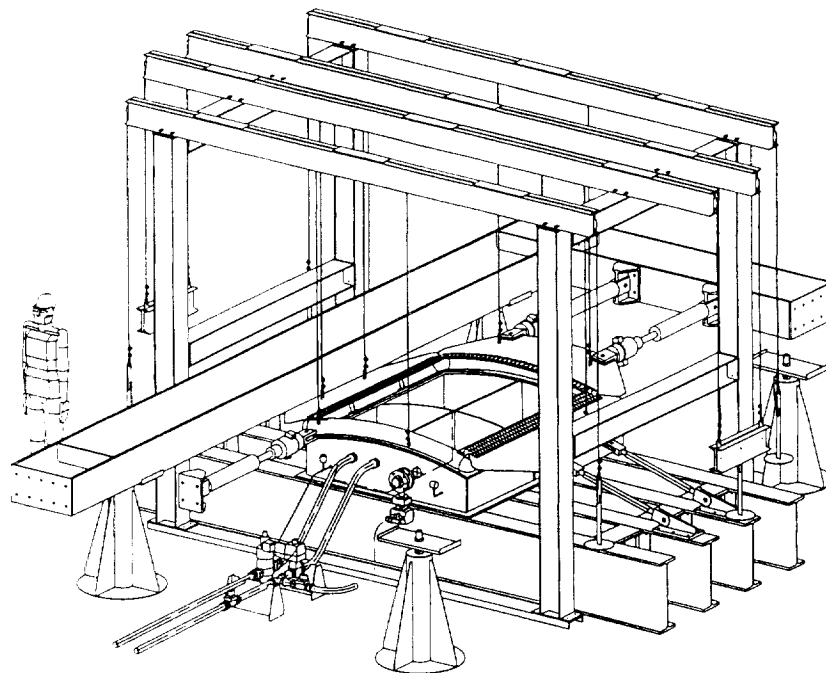

Figure 28. Cutaway view of pressure test box.

Finite element analysis was used to support the pressure test box design. Initial analysis results helped to modify test box design details to minimize interactions between the test fixture and undamaged panel stress states. Major load redistribution associated with large damage in a composite panel will require additional analysis developments to interpret damage tolerance tests performed in the pressure test box. Some issues that need to be addressed analytically relate to competing failure mechanisms similar to those discussed for axial damage tolerance; however, the pressure load component brings additional complexity, i.e. more Y- and C-factors, to stiffened shell problems. Complete documentation of the design, analysis, fabrication, and test performed to date is given in another paper presented at this conference (ref. 23).

Damage tolerance analysis needs. As was the case for metal design, e.g. ref. 9, a physical understanding of competing structural failure mechanisms and nonlinear analyses are needed to optimize the damage tolerance of composite panels. This insight is also needed to scale results from element and subcomponent tests to the full size fuselage. Hypothetically, the damage tolerance of composite designs has a stronger relationship with the scale of structural response than it does for metallic counterparts. This hypothesis is based on work from other engineering structures groups that have used materials which are heterogeneous at a scale larger than metal, e.g. wood and concrete. Fracture analyses for such materials is similar to a stability or collapse analysis in which nonlinear interactions with dimensions of the structural geometry dominate the response.

Damage tolerance analysis must be developed, verified by subscale tests, and then used to scale to a level of structural significance. Current ATCAS funding levels do not allow combined load damage tolerance testing at a scale which would eliminate the size effects predicted by an elastic continuum model. Elastic structural configuration effects (Y-factors) and load redistribution into adjacent stiffening elements (C-factors) for the pressure test box shown in Figure 28 were found to be significantly different than those which occur in the actual fuselage shell. The effects of progressive damage and nonlinear material response further complicates the interpretation of failure data from subscale tests. An estimated threefold increase in panel size would be needed to perform biaxial damage tolerance tests that are independent of the test fixture. Clearly, analysis methods are needed to avoid this expense.

Progressive damage and nonlinear modeling schemes for composites are currently being pursued to accurately predict Y- and C-factors. Damage will be simulated in analysis to represent its average affect on the structural load path as opposed to modeling discrete details. The use of generalized continuum approaches suitable for structural analysis are currently under study. Strain softening methods which have been used for tension fracture analysis, to simulate the reduced load carrying capability of a notch tip damage zone with increasing notch opening displacement, appear to be likely candidates (ref. 21). To date, these models have been developed to simulate reduced inplane stiffness and successfully applied for scaling the performance of concrete structures. Further developments are needed to include reduced bending stiffnesses, important coupling terms, and any out-of-plane plate response needed to simulate damage in problems involving postbuckled skins and pressure pillowing. Nonlinear transverse shear load transfer for both bonded and mechanically attached elements will also be needed for

C-factor analysis. Based on observations that the plastic response of metal joints can enhance damage tolerance, the attachment of elements for composite panels should have some yield to smear load redistribution over a longer shear lag distance.

Lamb wave dispersion measurements taken to characterize impact damage in composites (see Figure 23) directly support a generalized continuum approach to simulating damage. Similar NDE data was also collected for notch tip damage zones at various load levels during the course of stiffened panel fracture testing. The reduced bending stiffness calculated from these measurements tended to decrease approaching the notch tip. These stiffnesses continued to drop at any given location with each increasing load cycle. The zone of degraded stiffness also extended further away from the notch with increasing load application. Current microscopy and deply studies with tension fracture panels are attempting to characterize the details of notch tip damage and add physical meaning to wave dispersion measurements.

Panel Splices and Repair

Bolted joint studies for tow-placed crown laminates. Mechanically fastened longitudinal and circumferential splices are baseline for all ATCAS quadrants. Some bypass and bearing coupon tests for braided/RTM plates and ATP laminates have been performed to support local optimization for crown panel splices. Figure 29 shows plots of bypass and bearing data for the baseline crown skin material (ATP AS4/938) and several ATP hybrids considered for enhanced damage tolerance. Test points labeled "75% AS4/938, 25% S2/938" represent laminates in which each layer is an intraply hybrid. The other hybrid test points correspond to laminates in which only 0° plies are intraply hybrids.

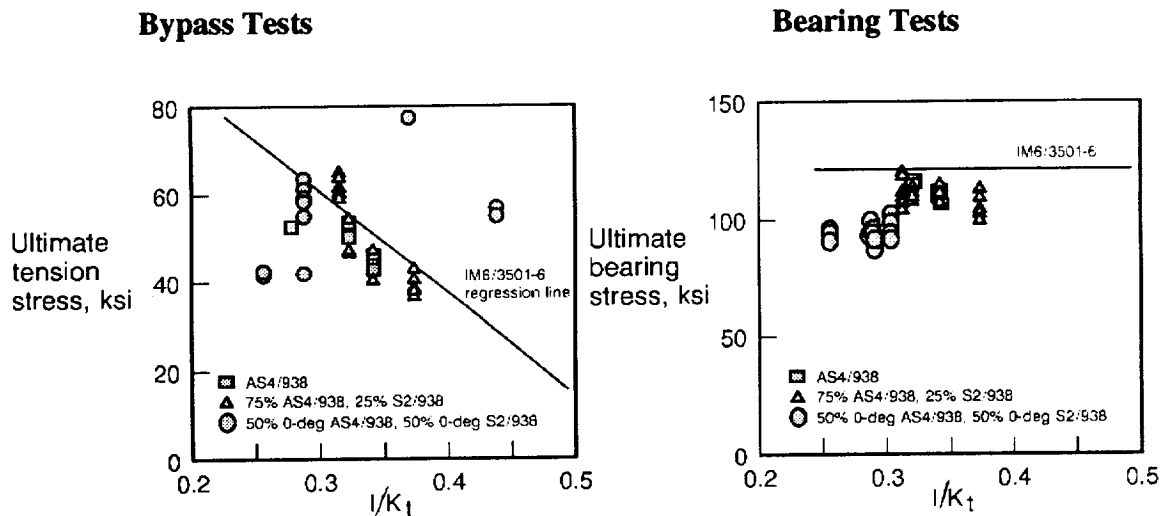

Figure 29. Bypass and Bearing test results for ATP laminates.

Data in Figure 29 is plotted versus the inverse of the orthotropic stress concentration at a hole in a uniaxially loaded plate ($1/K_t$). Regression lines in the two plots shown in the

figure represent average results for a large database of IM6/3501-6 laminates. Bypass data was collected using a filled hole coupon and titanium lockbolts with an effective clamp-up torque of 85 in-lb. High clamp-up torque was used to suppress stress relief mechanisms associated with notched tension failures (e.g., delamination). The bearing data was collected with specimens having low clamp-up torque (35 in-lb). This was done to simulate reductions in bearing strength due to real-time stress relaxation. Bearing and bypass test results are similar for the baseline ATP material and laminates consisting of intraply hybrids in each layer. Bypass data for these laminates tends to follow the regression line, indicating a strong correlation with $1/K_t$ and past IM6/3501-6 results. Bearing data for these two ATP laminates is independent of $1/K_t$ and appears slightly below the IM6/3501-6 trend line. Note that the other ATP hybrid has considerable scatter in the bypass test results. This was found to relate to the location of the hole relative to hybridizing fibers in the 0^0 layer. Bearing results for this hybrid were significantly less than other ATP laminates.

Repair for Large Penetrating Damage. Mechanically attached skin patches and element splice plates are currently being considered in ATCAS for repair of large penetrating skin damage that includes severed elements. One of the panels to be tested in the pressure test box will demonstrate the repair methods developed for failsafe damage. The specific damage case under consideration is an axially oriented, 22 in. long, skin penetration, centered on a severed frame element. A cooperative effort involving airline maintenance personnel will support this task with a critical evaluation of the repair procedure.

Work leading to the subcomponent repair demonstration includes design concept development, finite element analysis, manufacturing trials, and element tests. Several variables for repair design concepts are under consideration including: (a) titanium skin patch thickness, (b) composite patch material and laminate layup, (b) patch geometry, (c) mechanical fastener type, and (d) fastener attachment pattern. Finite element analysis is being performed in a subcontract at Oregon State University to support this effort. Analysis has been able to give some insight on how the repair design variables affect the damage strain concentration and load redistribution near the repair.

Figure 30 shows analysis results relating to the repaired damage strain concentration. Repair concept analyses were performed for the configured fuselage shell subjected to pressure load requirements and a flat stiffened panel having resolved hoop load conditions. A composite laminate patch was used for the analyses in Figure 30. This patch had the same stiffness properties as the undamaged composite skin. Load redistribution associated with the central frame repair was simulated by assuming a continuous element. Analysis results in Figure 30 indicate that the problem involving internal pressure is inherently more difficult. For example, patch geometry and fastening details are found to have a stronger effect for the pressure loaded curved panel. Additional analysis indicated that repair design variables which minimize the damage strain concentration tend to increase bearing/bypass loads for the mechanically fastened repair. The critical "Ultimate" load case for failure to the mechanical fasteners include fuselage body bending. Tension tests for specimens with mechanically fastened patches and nonlinear load transfer analysis of the curved panel will be pursued to avoid conservative predictions of the repair joint capability.

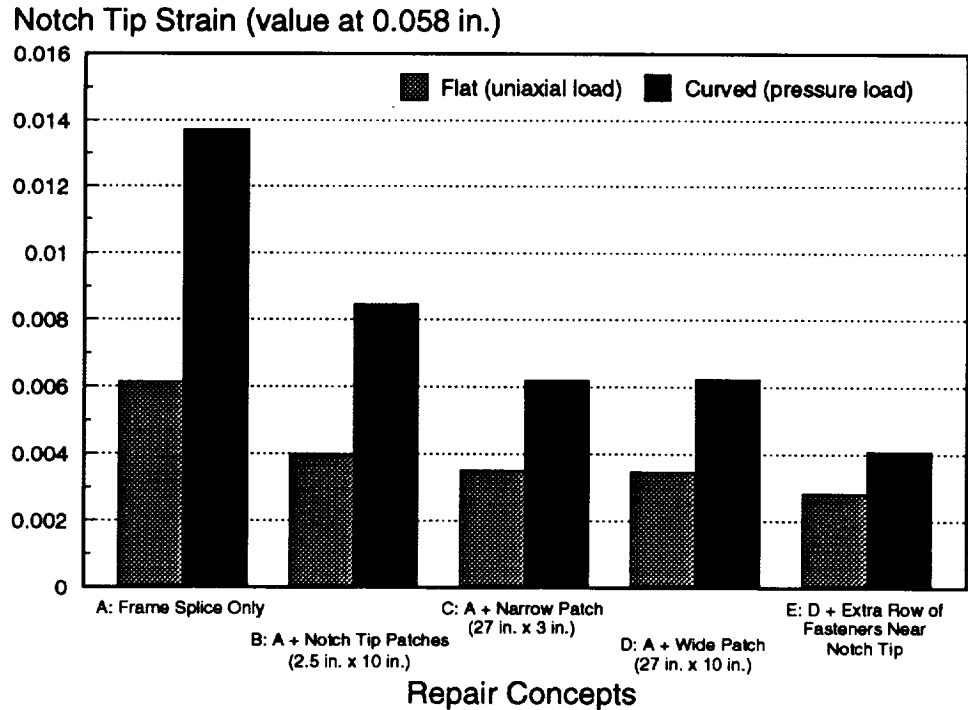

Figure 30. Structural analysis of repairs for large penetrating damage in minimum gage fuselage panels.

Design Cost Model Developments

Most initial efforts with the design cost model have concentrated on the fuselage crown quadrant. Local optimization for the crown was originally performed with the first version of the design cost model, UWCODA, which was developed under subcontract at the University of Washington (ref. 3). As discussed under "Manufacturing Scaleup", an enhanced version of the design cost model, called COSTADE, was used for crown redesign. During crown process development, relationships between manufacturing cost and crown design features were studied in greater detail. Process steps for ATP of skin and stiffener laminates, hat stiffener drape forming, braided/RTM frame fabrication, panel subassembly, and bagging have all been related to fuselage design details.

One example of the approach used for developing design/cost relationships is given in reference 16 for Braided/RTM batch processing of fuselage frame elements. This particular study also describes how fabrication trials for crown frames were used to calibrate the design cost relationships. Subcontract work at Dow/UTC supported this effort with a textile/RTM process database for other hardware design details.

Data was also collected to quantify manufacturing tolerances achieved with process trials. These included the final dimensions of fabricated parts, bonded element locational tolerances, and overall panel warpage. Based on these measurements, additional manufacturing steps will be considered in cost modeling as they relate to element subassembly, panel cure, quadrant assembly, and body join. Sensitivity studies will be used to evaluate the trade between higher tooling costs which help improve

manufacturing tolerances versus the increased costs associated with greater assembly labor for parts having tolerance mismatch. Analysis methods to predict the effect of design details on cured panel imperfections and element cross-sectional distortion were also developed to be included as constraints in COSTADE software (ref. 8).

Advanced crown structures. Although COSTADE software is being developed to support a hardware design engineers needs, it also has applications as a research and development tool. When considering the application of advanced technologies to future fuselage structures, several factors should be addressed by the DBT before committing research and development funds. An assessment of aircraft configuration, cost versus weight goals, and technology risk should be made to support major design decisions, e.g. materials and processes, design family type, and component panel sizes. Data available to the DBT can be combined with the COSTADE tool to perform bounding analyses on the cost and weight of differing configurations, load conditions, and design features. Examples of using COSTADE for such studies on advanced crown structures is presented in another paper given at this conference (ref. 24). The paper explores the effect of loads, fuselage length and diameter, crown panel size, and design type, i.e. stiffened panel versus sandwich.

A designed experiment (DE) module, based on Taguchi principles (ref. 25), was added to COSTADE. This software provides an efficient means of performing sensitivity and risk analyses for input parameters and design variables. The DE can be used to screen the effects of critical input parameters (process cost data, loads, material properties, and design groundrules), helping a DBT to decide what cost or design drivers should receive the most attention during development. For example, a range of estimates on the properties and costs for new materials and processes may exist long before funds have been committed to develop the technology and collect a complete data set. An initial risk analysis can be performed with the estimates to judge if the potential payoff is worth the developments required. The sensitivity of cost or performance to interactions between processes and specific composite design details can also be investigated using a designed experiment. One example of this DE application is the effect of process tolerance control on design detail, e.g. ply layup orientations, and the resulting changes in performance. This would help ensure that the DBT selects design details that are compatible with known process variations.

Blending function development. Advanced optimization schemes are being developed for COSTADE under subcontract to the University of Washington. The goal is to develop methods to facilitate design trade studies that include many design variables and large panels. The global random search algorithm originally developed for UWCODA has been incorporated into COSTADE. A dual cost and weight optimization scheme was added to allow the user to identify an allowable cost increase per unit weight savings.

The "quadrant" fuselage panel approach to cost savings is based on the contention that large composite panels can be effectively designed to meet the requirements of a variable load space. In order to achieve projected cost and weight savings, design details of a large panel must be effectively blended from point to point in a manner that maintains manufacturing efficiency while minimizing weight. Blending design details of a large composite panel is a difficult task for the DBT. This problem relates to current limits in

design sizing methods and a desire to consider the effect of structural details on total costs (element fabrication and assembly) when making design selections. Analysis tools and subcomponent test data used to size panels in hardware programs are based on point load conditions, while the total assembled panel cost will relate to interactions between features of the complete design. As a result, design details that meet load conditions at one spot in the panel must be selected such that they cost effectively blend to match details selected for another part of the panel. Line load diagrams shown in Figure 31 illustrate the difficulty in blending design details for large fuselage panels.

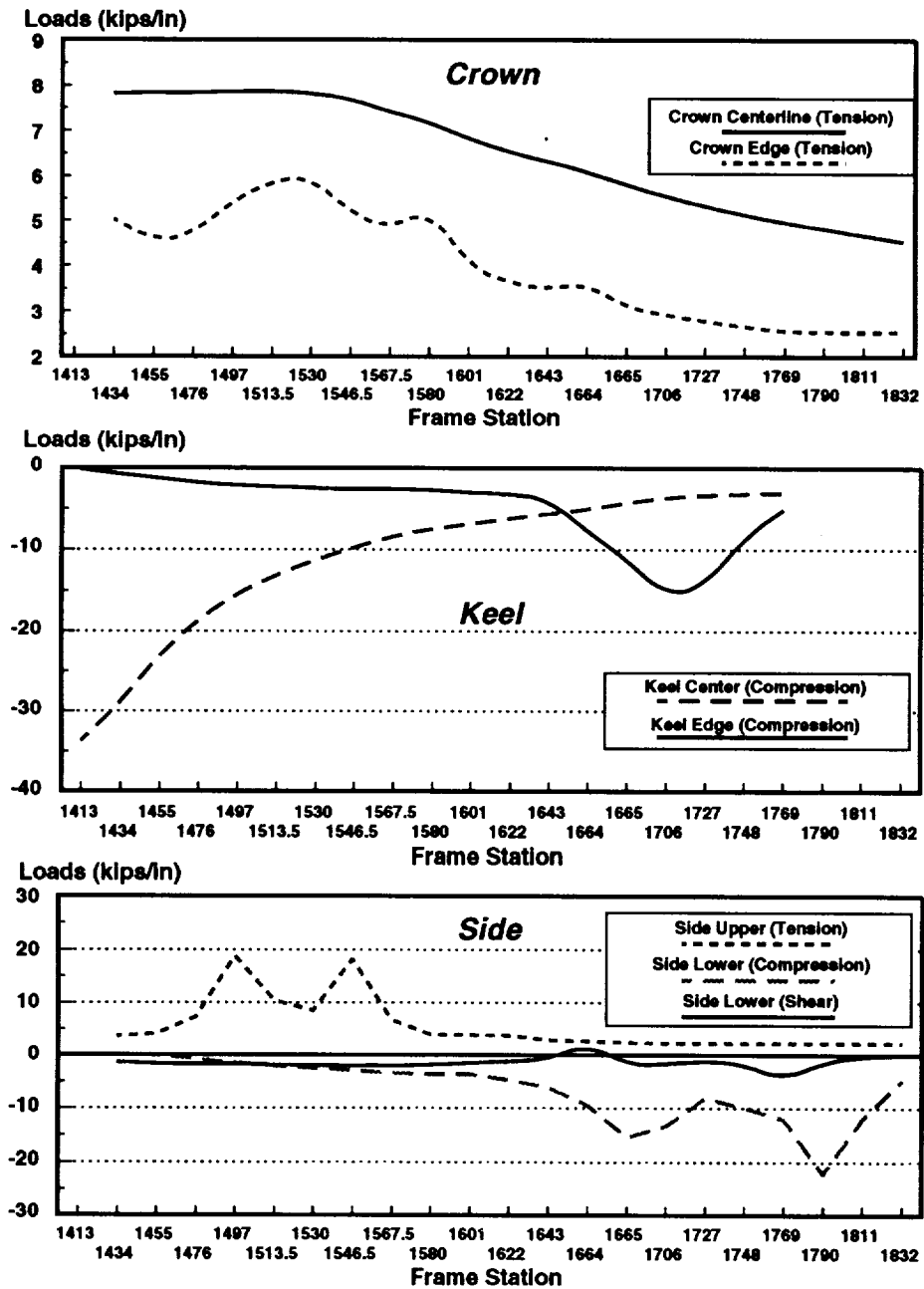

Figure 31. Variations in critical load cases along the length of ATCAS crown, keel, and side quadrants.

The three graphs in Figure 31 plot critical line load variations for portions of each ATCAS quadrant. When attempting to blend design details from point to point in a large panel, the DBT would like to make decisions that minimize total panel cost. This is particularly difficult for side and keel fuselage panels in which major cutouts, such as the wheel wells and cargo doors, cause loads to vary over a wide range. For example, an ATP machine could not be expected to change tow materials when processing from one edge of a side quadrant panel to the other, despite the differing needs in response to 20 kip/in. and -20 kip/in loads near door cutouts in the upper and lower sides, respectively. Similarly, the selection of a constant stiffener spacings that meets load requirements in both the forward and aft ends of a stiffened keel panel design requires blending to minimize cost and weight.

The concept of an automated "blending function" to support design sizing exercises for variable load conditions, while attempting to minimize panel cost and weight, was introduced in reference 12. To date, the University of Washington subcontract has developed crown panel blending software for skin and stiffener layup, ply drops, stiffener geometry, and stiffener spacing. Figure 31 shows that the crown has the least load variation of all quadrants. Difference between maximum and minimum loads for keel and side panels is four times greater than those for the crown. Keel and side panel blending function development is a major task supporting the design cost model.

Keel

Figure 32 shows characteristics of the ATCAS keel quadrant. This quadrant is the smallest of the four that comprise the fuselage barrel section. Several manufacturing and structures technologies for the keel are currently under development. This section will briefly review the work being performed for local optimization, future manufacturing scaleup, and major tests planned in 1993 through 1994.

- Forward: Thick Tow Placed Laminate (AS4/8553-40, 40% RC)
- Aft: Advanced Sandwich Concept (Core Under Development)
- Lockheed Textile Frames and Intercostal (Under Development)

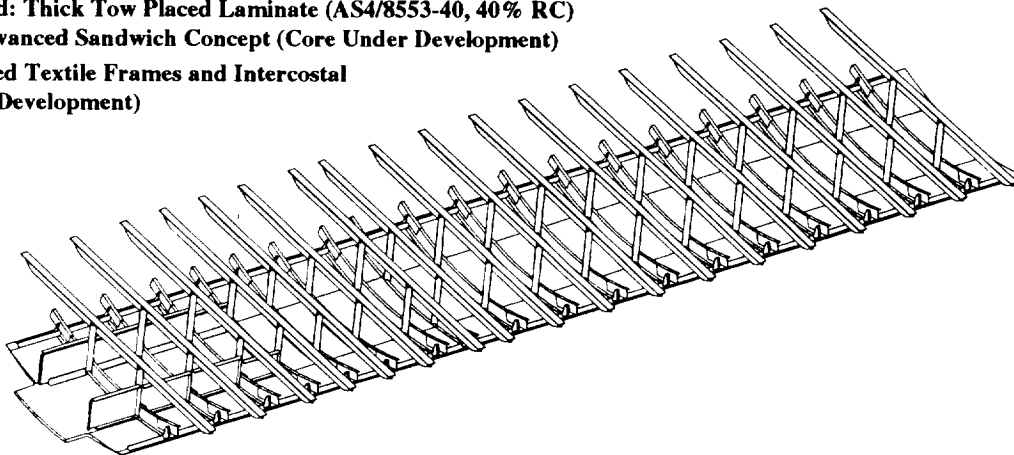

Keel Quadrant: 34° Segment

Figure 32. Baseline keel design, materials, and processes.

Some important details of the keel panel design are not evident in Figure 32. A thick laminate is used as a "panelized keel beam" at the forward end of the quadrant to

facilitate major compression load redistribution. This thick laminate transitions into a sandwich panel by dropping plies, while adding core to maintain constant IML and OML diameters along the length of the panel. The aft end of the keel is traditional sandwich with facesheet thicknesses on the order of 0.1 in. Skin material type selected for the keel utilizes a toughened matrix. The DBT selected this matrix based on anticipated benefits from interlaminar toughness and compression damage tolerance. Textile elements selected as baseline for the keel quadrant will be developed and optimized under Lockheed's leadership. Reference 7 gives additional details on the design shown in Figure 32, including projected cost, weight, and technical issues to study.

Local Optimization Tasks

Local optimization for the keel started in the spring of 1992 and is scheduled to be completed early in the summer of 1993. Three main areas of work comprise local optimization. First, manufacturing trials are being performed to help develop processes, quantify cost/design detail relationships, and optimize process steps to minimize labor. Second, a test database and supporting analyses are being generated to quantify skin and core materials. Process development and mechanical characterization of several advanced sandwich core materials is being performed concurrently. A core material will be selected in the fall of 1992, based on results from both activities. The third part of local optimization is the development of design and cost constraints for use in COSTADE. This design cost model tool will make use of results from manufacturing trials and the material database to help the DBT optimize final design details for major keel test hardware.

Process development and mechanical tests for the aft keel design detail will proceed at a faster rate than those for the forward. The final aft and forward keel verification tests will occur in 1993 and 1994, respectively. Additional time is needed for the forward keel due to issues that are inherently more difficult. The aft keel has relatively uniform compression loads that are of a magnitude similar to those at the forward end of the crown; hence, the DBT is better equipped to address aft keel issues in response to the aggressive schedule which has been planned. Crown studies have also indicated that similar cost and weight savings to skin stiffened designs appear possible with sandwich panels (refs. 1 and 24). Aft keel sandwich developments will help supplement the ATCAS crown database in a way that both design families could be considered for quadrants in the Phase C full barrel.

Advanced sandwich concepts. Several core concepts are currently being evaluated for use in the keel panel. The typical range of densities considered for keel requirements range from 7 to 20 lb/ft³. Some isolated areas near the start of the thick laminate to sandwich core transition and at ramps near splices may reach higher densities. The baseline core material used in global design sizing studies was Rohacell foam. Other candidates under investigation include foams fabricated using the Sundstrand insitu process and an advanced DuPont porous solid. Several glass/phenolic and glass/thermoplastic honeycombs with different cell sizes and density will be screened. The development of foam-filled honeycomb processes will be pursued in coordination with Hexcel. Finally, syntactic foam with significantly higher densities will be considered for use as interlayers between plies in "thick-skin" concepts for stiffened panel design. This design concept is

a mix between skin/stiffened and sandwich designs whereby greater skin bending stiffness helps to satisfy skin buckling and pressure pillowing requirements while allowing wider stiffener spacing and the associated reduced cost (see ref. 24).

Cost savings potential projected for the Sundstrand insitu foams, coupled with a need for significant developments, lead to a desire to begin process trials in support of ATCAS keel technology in early 1991. The Sundstrand process uses a single thermal cycle to create the foam and cure facesheets to form a sandwich panel. This eliminates many of the traditional sandwich manufacturing steps, reducing cost significantly. The ATCAS DBT was interested in developing a thermoset insitu foam technology that was compatible with the baseline keel facesheet material. Following initial trials of foaming the base facesheet resin, a decision was made to use resin in powder forms. The improved mixing obtained with powder resin forms and foaming additives was thought to be critical for process scaleup. Powder resins used for the foaming trials included 3M PR500 and Hercules 8553-40. Several process trials were successfully performed at Sundstrand during the course of their subcontract, yielding samples for mechanical test at Boeing. Figure 33 shows a sample cross-section taken from one of the sandwich panels. The details of thermoset insitu foam process development are given in reference 26.

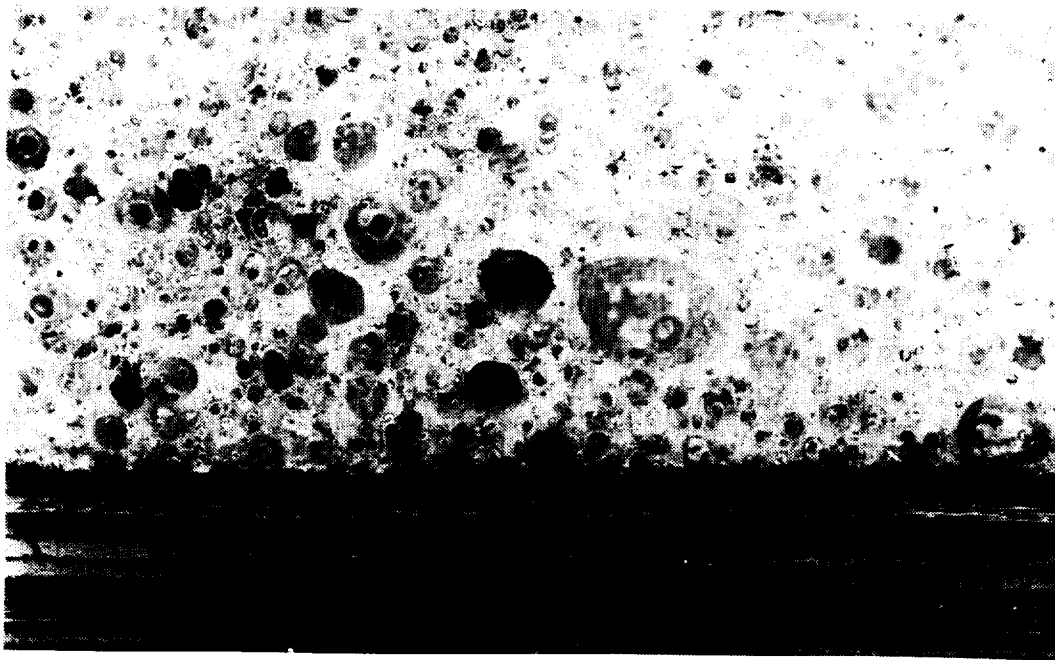

Figure 33. Micrograph taken from an insitu foam process trial.

Mechanical tests performed at Boeing to screen samples of the insitu foamed sandwich included impact resistance, 3- and 4-point flexure, flatwise tension, and flatwise compression. A number of different insitu foams were evaluated, indicating a trade in mechanical properties that depended on process variables. Figure 34 shows a trade between strength and toughness that was observed with 3-point bend tests for two different insitu foam samples. The foam sample which exhibited relatively high strength and low toughness was processed from 3M resin, without fiber additives. The sample

showing higher toughness and a sacrifice in strength had short Amoco P55 fiber additives. Further developments with the insitu foam process are needed to obtain the proper balance in core strength and toughness required for keel applications.

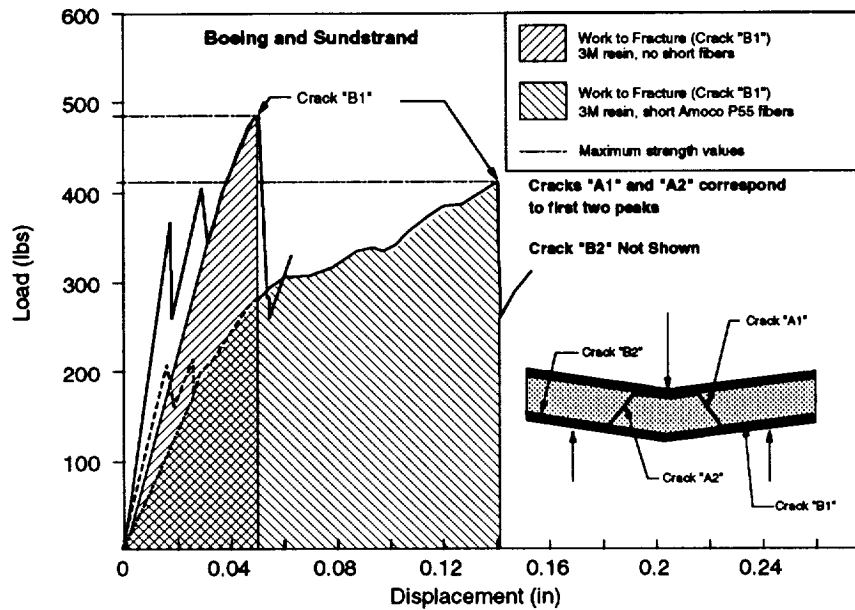

Figure 34. Strength versus toughness trades for insitu foam materials.

Another keel process activity that started early was the development of NDI methods for inspecting foam core samples. A resolution of this technical issue was needed before committing major efforts to foam core process development. Samples of Rohacell foam were used in ultrasonic experiments to judge their wave propagation characteristics. Foam samples effectively filtered the entire signal sent at frequencies typically used for inspecting graphite/epoxy laminates, e.g. 5 Mhz. Experiments performed over a range of frequencies, indicated that foam samples would pass lower frequency ultrasound (between 250 khz and 1 Mhz). Impact damage created in the foam core of sandwich panels was detected using through-transmission-ultrasound at 250 khz. In order to evaluate the extent of impact damage in face sheets over foam core, pulse-echo data was collected at 5 Mhz. These experiments helped to relieve concern on the inspectibility foam cored sandwich panels.

Keel process development needs. Design detail associated with major load redistribution poses a number of challenges in developing composite keel manufacturing technology. One key issue considered during baseline concept selection was a need to maintain IML tolerances as the structure changed from the forward to aft ends of the keel. The advanced sandwich concept selected by the DBT will be developed to maintain tolerances when going from a thick laminate in the forward end to sandwich panel in the aft (i.e., core is added as plies drop). The ATP laminate layup process will need to drop and add plies under tight tolerance control without a major impact on machine speed. This will require advancements in tow placement head technology and machine

programming control. There may also be a need to alter fiber angle within individual plies as a function of distance. This desire will relate to details of composite shear load transfer (both inplane and transverse) near the forward end of the keel. For example, shear load transfer mechanisms may force ply drops over too large an area to achieve economic and weight benefits without fiber angle change.

Other issues to consider in keel process development include a cure cycle for advanced sandwich structure. Time sequences of temperature and pressure for the cure cycle must process toughened matrix material in a thick laminate and sandwich facesheets concurrently. The pressure needed to cure AS4/8553-40 in a thick laminate versus that allowed by the sandwich core may be a critical part of the technology. Alternative facesheet materials will be considered for the keel if AS4/8553-40 is found to be incompatible with keel process requirements.

Building block test and analysis. Plans have been developed to evaluate aft and forward keel design drivers with coupons, elements, and subcomponent panel tests. Tests and supporting analyses will help to design the final curved panel verification tests. Coupons cut from sandwich process trials will be used to obtain core shear properties and impact resistance. These dominate initial aft keel tests and will be used to support core material selection. Aft keel sandwich process trials at a larger scale will yield compression panels for stability, post-impact residual strength, and large notch tests. Curved panels on the order of 3 ft. by 4 ft. will be the largest tested prior to final verification.

Forward keel building block tests will concentrate on issues related to load redistribution and transverse shear properties. Process trials will again provide panels for testing. Forward keel coupon tests will help to characterize the material for thick laminate behavior, ply drop, bearing, and open hole strength. The transverse shear lag response of the composite laminate and its effect on major load redistribution will be a critical issue for these studies. The AS4/8553-40 material has resin-rich interlayers (RIL) that have a lower transverse shear stiffness and high interlaminar fracture toughness. This characteristic is generally good for impact damage resistance, but may affect local load redistribution in areas where plies buildup (i.e., long shear lag distances may limit doubler plies from carrying their full load share).

Unlike results for brittle matrix laminates, uniaxial compression ply drop tests for materials having RIL fail at load levels characteristic of the thin end of the specimen. This suggests RIL laminates have either superior ply drop strength or that the dropped plies did not pick up significant amounts of load for the specimen length. Larger test panels will be designed to evaluate this effect. The tests will include thick laminates having ply drops and major cutouts. The data and supporting analyses will help determine internal load redistribution and required doubler sizes for the forward keel design detail. If the required advances in ATP manufacturing are attained, some tests and analysis will evaluate compression load redistribution for panels with intraply fiber angle changes around cutouts.

Design cost model. Developments for keel cost and design constraints will occur during local optimization. Design/cost relationships will initially be developed based on the global detailed estimates for keel processes. All relationships will be updated based on

data generated during process trials. For example, the cost constraints for ply drop and add will be changed to reflect ATP machine head developments and process trials. Textile relationships will be developed in coordination with Lockheed process studies. Formulation of a blending function algorithm for keel design details will need to account for large load variations discussed earlier in reference to Figure 31. Design sizing tools for sandwich panels will require additions to those currently existing in COSTADE for stiffened crown structures. Design constraints for doubler plies will need to be formulated based on shear lag tests and analysis for the material of interest. Once developed, the COSTADE modules will be applied to optimize a final keel panel design.

Manufacturing Scaleup and Major Tests

Manufacturing scaleup for the aft keel will occur in early 1993. The final panels processed in support of the aft keel will be used for uniaxial compression damage tolerance and repair tests. The panel geometry to be used for aft keel manufacturing and test verification is shown in the top of Figure 35. Due to several difficult manufacturing issues, forward keel scaleup will occur over a longer period of time than the aft panel, culminating with a manufacturing demonstration in early 1994. The forward keel load redistribution test component is illustrated at the bottom of Figure 35.

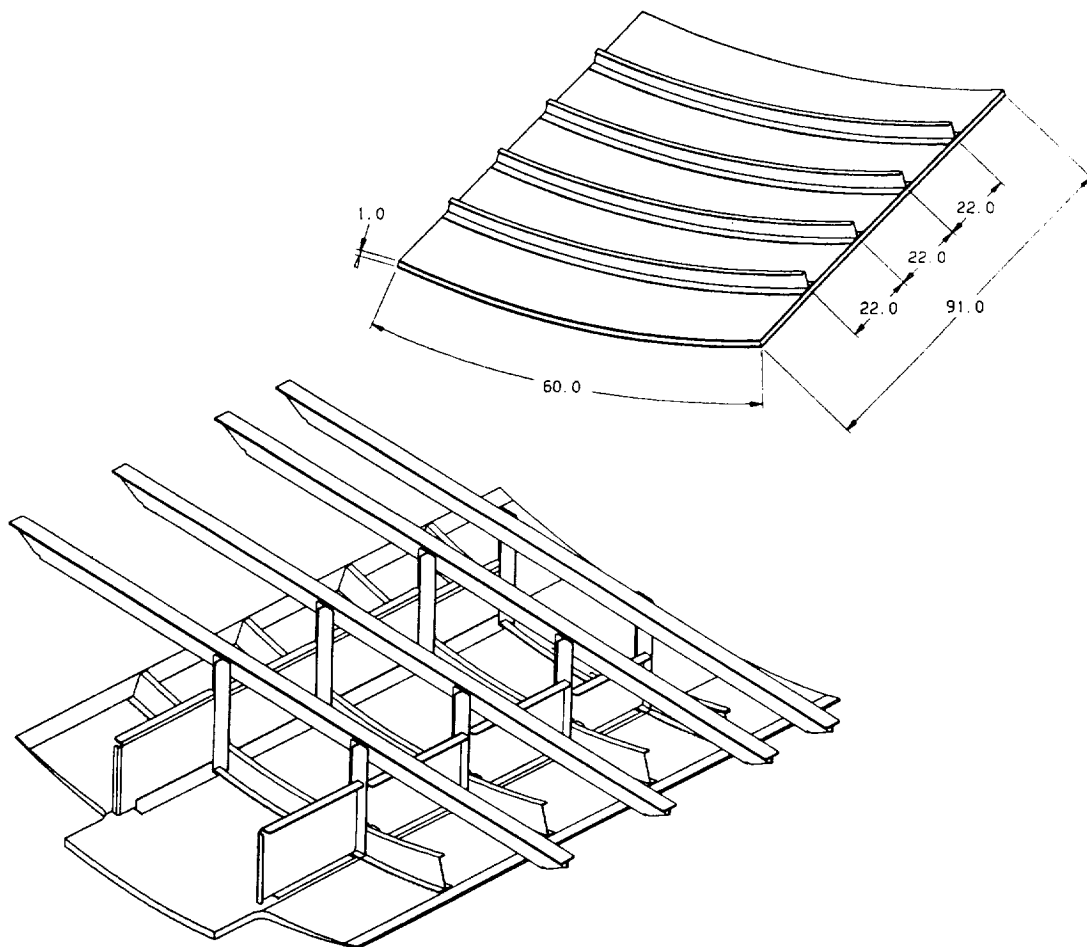
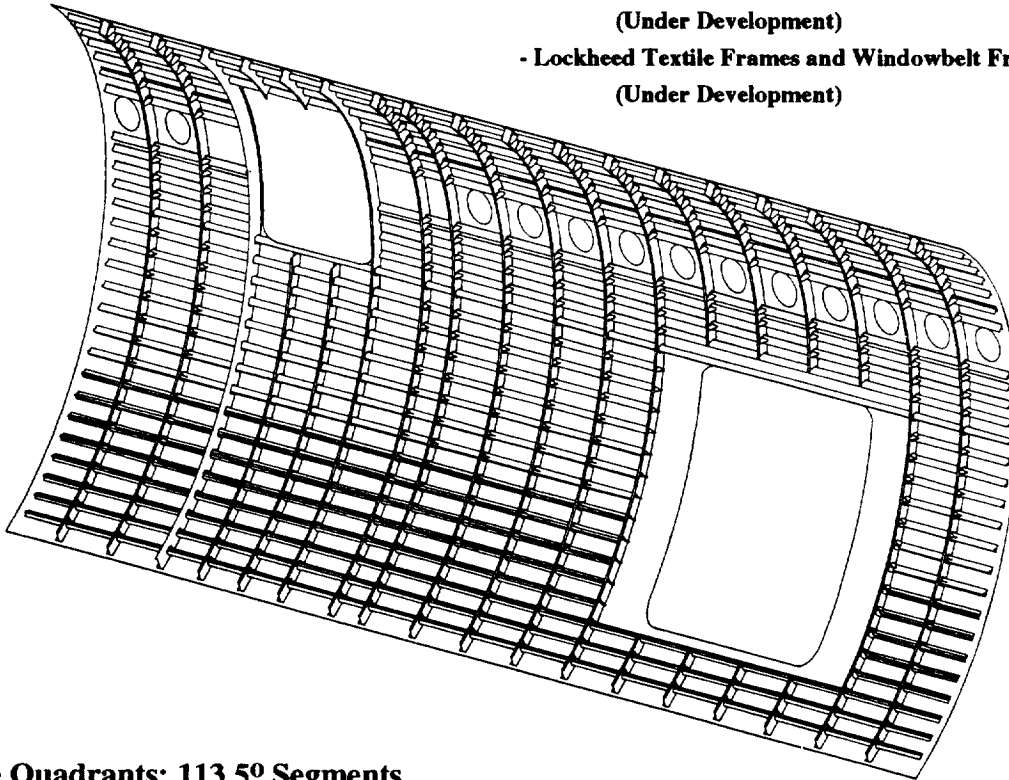

Figure 35. Aft and forward keel verification test panels.

Side

Figure 36 lists initial characteristics of ATCAS side quadrants. These two quadrants are the largest of the four. Only baseline selection is complete for the side. Global evaluation, which will be performed in coordination with Northrop (ATCAS subcontract supporting COSTADE) and Lockheed (ACT contract studying textile technologies), is scheduled to begin shortly. This section will briefly discuss the scope of side quadrant studies.

- Cured J-stiffeners and Cobonded J-Frames
- Tow Placed Skin: AS4/8553, 38% RC
- Stiffener Process: AS4 or IM6/8553, 35% RC
(Under Development)
- Lockheed Textile Frames and Windowbelt Frames
(Under Development)



**Side Quadrants: 113.5° Segments
(Right Side Pictured)**

Figure 36. Baseline side design, materials, and processes.

Figure 36 shows the right side quadrant. Global trade studies will begin with the left side which excludes the cargo door. Current ATCAS schedules show that the right side will not be addressed until Phase C. Large side quadrants made selection of the baseline concept difficult. Much of the side panel area is minimum gage and driven by pressure damage tolerance. Some weight penalty will be incurred for using toughened matrix material for these parts of the side; however, compression/shear requirements in the lower side suggest possible advantages in using such material for other issues (e.g., impact). As discussed for the forward keel, it is currently unclear if a toughened matrix material is best suited for ply buildups near cutouts. The use of a Family C design that includes cobonded frames and windowbelt design details will be critically evaluated. Depending on the results of global evaluation, baseline selections may be superseded.

Manufacturing Scaleup and Major Tests

Manufacturing scaleup is planned in four main areas of the side quadrant. A lower side panel will be developed first. The second area includes windowbelt design details. The last two areas to develop are side upper and lower longitudinal splice details with crown and keel panels, respectively. Combined load tests are planned using a fixture that is suitable for compression, shear, and internal pressure loads. It is also desirable to study dynamic pressure release (e.g., simulated blade penetration) and damage containment using the fixture with panels of sufficient size. The supporting analysis will consider coupling fluid flow (dynamic gas release through the penetrated opening) and mechanics (damage containment under combined load conditions) parts of the problem. Figure 37 shows preliminary designs of windowbelt and lower side test panels. Figure 38 shows the upper and lower longitudinal splice concepts.

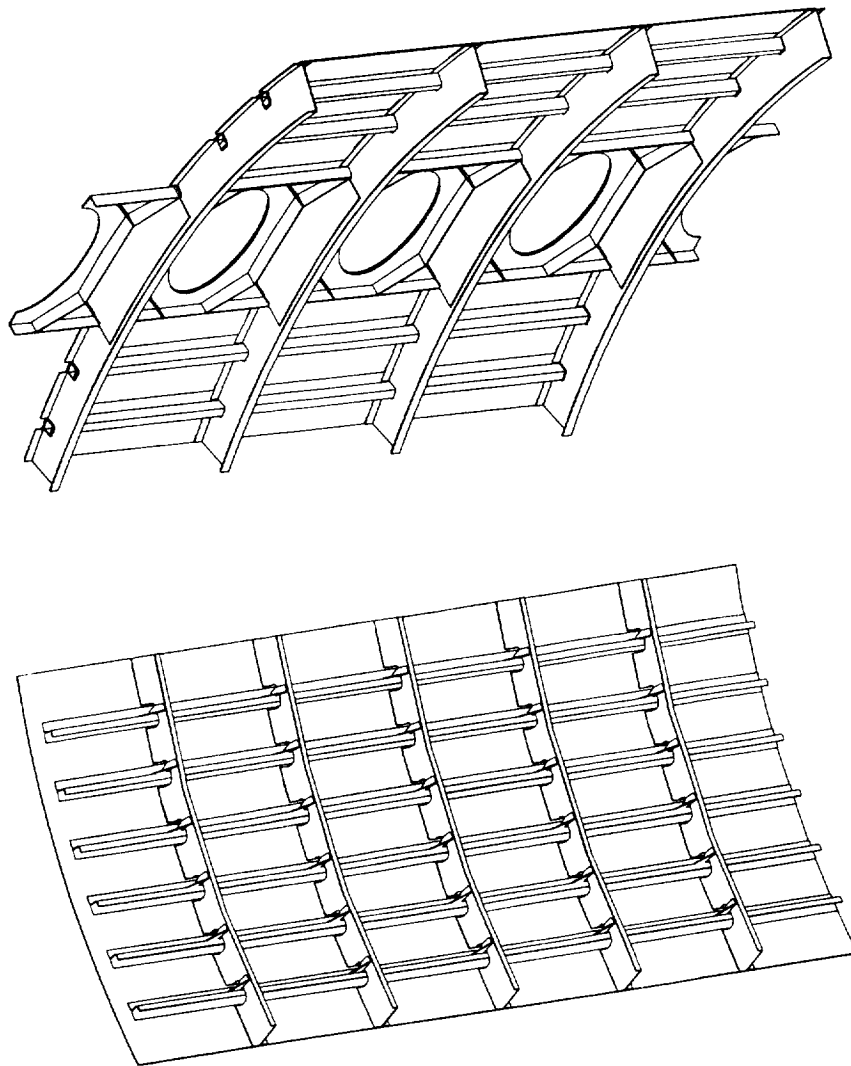

Figure 37. Side quadrant verification test panels.

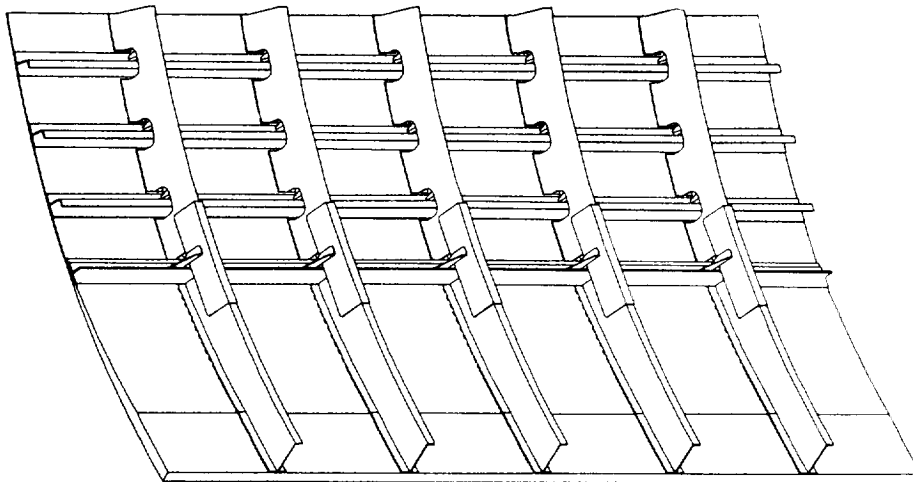
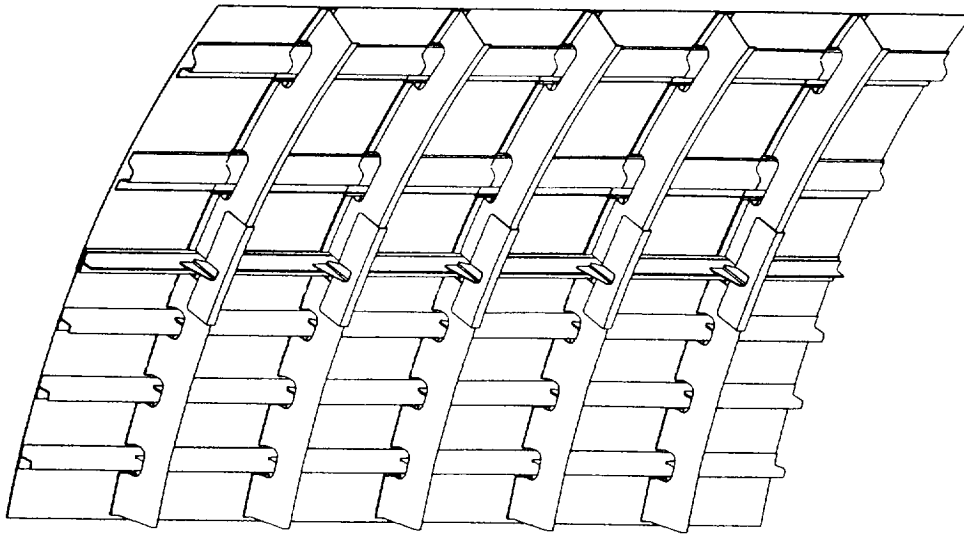

Figure 38. Longitudinal splice verification test panels.

SUMMARY

Boeing's ATCAS program on a composite fuselage barrel section was reviewed. Projections of cost and weight savings versus aluminum transport fuselage highlight *why* ATCAS is pursuing composite technology. Recent metal advancements were found to decrease composite weight savings previously reported for fuselage crown panels from 45% to a range between 20% and 35%. Composite cost savings appear attractive,

assuming material costs can be reduced as projected for the necessary high volumes and efficient factory flow can be achieved with the design details required to meet fuselage performance constraints. In order to ensure the latter, ATCAS is studying manufacturing costs and issues for representative design details. Design cost relationships generated by these studies will be used to form the basis for a model that constrains composite hardware design to promote efficient use of selected processes. The ATCAS program will continue to keep track of metal fuselage advances to ensure a critical assessment of composite technology developments.

A critical technology path describing *how* ATCAS plans to develop transport fuselage technology was summarized. This included an initial Phase C proposal to increase the scale of fuselage barrel manufacturing demonstration and test verification. A task to study structures in the wing to body intersection was also discussed as part of Phase C. Ten technology issues to be addressed during the course of ATCAS Phases A, B, and C were highlighted. The authors would be grateful to receive critical reviews of the plan.

Crown and keel panel tasks dominated *what* has been achieved in ATCAS since the second ACT conference. Important points are summarized below.

- 1.) A special DBT was established to solve crown design/manufacturing problems, allowing process scaleup to a curved, 7 ft by 10 ft, panel with six cocured stiffeners and five cobonded frames. A number of other large manufacturing demonstrations were performed to develop new processes including braided/RTM frames, automated tow placed skins and stiffeners, and advanced cure tooling.
- 2.) Design cost model developments for the crown provided timely support to the DBT in obtaining a solution to problems having constraints that are analogous to actual hardware applications. Design and manufacturing relationships for crown processes were studied in detail to update the model. Several advancements in COSTADE software were also achieved for the crown.
- 3.) Results from a large tension fracture database suggested a composite strength versus toughness trade similar to that observed with aluminum alloys. Automated tow placed laminates were found to have significantly higher large notch strengths (over 30%) than tape materials consisting of the same constituents. Intraply hybrids had toughness properties exceeding those of advanced aluminum.
- 4.) Axial tension damage tolerance was demonstrated for composite crown designs using 5-stringer panels. A failure strain of 0.004 in/in was measured for a hybrid composite panel having failsafe damage (14 in. skin penetration with severed central stiffener). Similarities in competing structural failure mechanisms for composite and metallic designs were interpreted based on tests and analysis.
- 5.) Initial design and fabrication of a pressure test box was completed. This test fixture will be used for biaxial tension loading (including pressure) of curved configured fuselage panels.
- 6.) Global evaluation of an innovative keel panel design was completed, showing cost and weight savings potential versus aluminum structure.
- 7.) Process and material development for advanced sandwich keel concepts began.

Eleven papers presented at this conference give more details on ATCAS progress.

REFERENCES

1. Ilcewicz, L.B., Walker, T.H., Willden, K.S., Swanson, G.D., Truslove, G., Metschan, S.L., and Pfahl, C.L.: *Application of a Design-Build-Team Approach to Low Cost and Weight Composite Fuselage Structure*, NASA CR 4418, 1991.
2. Ilcewicz, L.B., Smith, P.J., Walker, T.H., and Johnson, R.W.: *Advanced Technology Commercial Fuselage Structure*, First NASA Advanced Composite Technology Conference, NASA CP-3104, Part 1, 1991, pp. 127-155.
3. Swanson, G.D., Ilcewicz, L.B., Walker, T.H., Graesser, D.L., Tuttle, M.E., and Zabinsky, Z.B.: *Local Design Optimization for Composite Transport Fuselage Crown Panels*, Second NASA Advanced Composite Technology Conference, NASA CP-3154, 1991, pp. 243-262.
- 4.) Walker, T.H., Avery, W.B., Ilcewicz, L.B., Poe, C.C., Jr., and Harris, C.E., *Tension Fracture of Laminates for Transport Fuselage - Part I: Material Screening*, Second NASA Advanced Composite Technology Conference, NASA CP-3154, 1991, pp. 197-238.
- 5.) Walker, T.H., Ilcewicz, L.B., Polland, D.R., and Poe, C.C., Jr., *Tension Fracture of Laminates for Transport Fuselage - Part II: Large Notches*, Third NASA Advanced Composite Technology Conference, CP-3178
- 6.) Swift, T., *Damage Tolerance in Pressurized Fuselages*, presented at the 14th Symposium of the International Committee on Aeronautical Fatigue - New Materials and Fatigue Resistant Aircraft Design, 1987.
- 7.) Flynn, B.F., Morris, M.R., Metschan, S.L., Swanson, G.D., Smith, P.J., Griess, K.H., Schramm, M.R., and Humphrey, R.J., *Global Cost and Weight Evaluation of Fuselage Keel Design Concepts*, Third NASA Advanced Composite Technology Conference, CP-3178, 1992.
- 8.) Mabson, G., Flynn, B., Swanson, G., Lundquist, R., and Rupp, P., *Dimensional Stability of Curved Panels With Cocured Stiffeners and Cobonded Frames*, Third NASA Advanced Composite Technology Conference, CP-3178
- 9.) Swift, T., *Fracture Analysis of Stiffened Structure*, in *Damage Tolerance of Metallic Structures: Analysis Methods & Appl.*, ASTM STP 842, 1984, pp. 69-107.
- 10.) Joynes, D., *Design of Advanced Composite Components for Maintainability Based on Inservice Experience*, presented at the American Institute of Aeronautics and Astronautics Conference, AIAA 92-1085, 1992.
- 11.) Masters, J.E., and Fedro, M.J., *Observed and Predicted Failure Mechanisms in Triaxially Braided textile Composites*, Third NASA Advanced Composite Technology Conference, CP-3178
- 12.) Freeman, W., Ilcewicz, L., Swanson, G., and Gutowski, T., *Designer's Unified Cost Model*, Second NASA Advanced Composite Technology Conference, NASA CP-3154, 1991, pp. 27-46.

- 13.) Willden, K., Metschan, S., Grant, C., and Brown, T., *Composite Fuselage Crown Manufacturing Technology*, Second NASA Advanced Composite Technology Conference, NASA CP-3154, 1991, pp. 263-290.
- 14.) Willden, K., Gessel, M., Grant, C., and Brown, T., *Manufacturing Scale-up of Composite Fuselage Crown Panels*, Third NASA Advanced Composite Technology Conference, CP-3178
- 15.) Grant, C.G., Bensom, V.M., *Automated Fiber Placement - Evolution and Current Demonstrations*, Third NASA Advanced Composite Technology Conference, CP-3178
- 16.) Metschan, S., Willden, K., Andelman, R., and Sharpless, G., *Cost Model Relationships Between Flexible Manufacturing Processes and Design Details for Transport Fuselage Elements*, Third NASA Advanced Composite Technology Conference, CP-3178.
- 17.) Dost, E.F., Avery, W.B., Ilcewicz, L.B., Grande, D.H., and Coxon, B.R., *Impact Damage Resistance of Composite Fuselage Structure, Part 1*, Proc. of Ninth DoD/NASA/FAA Conf. on Fibrous Composites in Struct. Design, FAA Publ, 1991.
- 18.) Dost, E.F., Finn, S.R., Murphy, D.P., and Huisken, A.B., *Impact Damage Resistance of Composite Fuselage Structure, Part 2*, Third NASA Advanced Composite Technology Conference, CP-3178.
- 19.) Horton, R. et al., *Damage Tolerance of Composites, Final Report*, Vol. 3, AFWAL-TR-87-3030, Air Force Wright Aero. Labs., Dayton, OH, May, 1988.
- 20.) Tang, B., Henneke, E.G., and Stiffler, R.C., *Low Frequency Flexural Wave Propagation in Laminated Composite Plates*, Proc. of Acousto-Ultrasonics: Theory and Application, 1988.
- 21.) Mazars, J., and Bazant, Z.P. (eds.), *Cracking and Damage: Strain Localization and Size Effect*, Elsevier Applied Science, 1988.
- 22.) Cairns, D., Walker, T., and Ilcewicz, L., *Response of Automated Tow Placed Laminates to Stress Concentrations*, Third NASA Advanced Composite Technology Conference, CP-3178
- 23.) Smith, P.J., Koch, W.J., Bodine, J.B., and Preuss, C.H., *Design, Analysis, and Fabrication of a Pressure Box for Tension Damage Tolerance Testing of Curved Fuselage Panels*, Third NASA Advanced Composite Technology Conference, CP-3178.
- 24.) Swanson, G.D., Metschan, S.L., Morris, M.R., and Kassapoglou, C., *The Effects of Design Details On the Cost and Weight of Fuselage Structures*, Third NASA Advanced Composite Technology Conference, CP-3178
- 25.) Wheeler, D.J., *Understanding Industrial Experimentation*, Statistical Process Controls, Inc., Knoxville, Tennessee, 1987.
- 26.) Saatchi, H., Durako, B., Reynolds, D., Dost, E., and Willden, K., *In-Situ Processing Methods for Composite Fuselage Sandwich Structures*, Third NASA Advanced Composite Technology Conference, CP-3178