

11512022

**COST MODEL RELATIONSHIPS BETWEEN TEXTILE  
MANUFACTURING PROCESSES AND DESIGN DETAILS FOR  
TRANSPORT FUSELAGE ELEMENTS<sup>1</sup>**

Stephen L. Metschan  
Boeing Commercial Airplane  
Structural Designer

514-24

51297

Kurtis S. Wilden  
Boeing Commercial Airplane  
Manufacturing Research and Development

Garrett C. Sharpless  
Fiber Innovations  
Braid/Resin Transfer Molding

Rich M. Andelman  
Dow/United Technologies Composites  
Cost Modeling

## SUMMARY

Textile manufacturing processes offer potential cost and weight advantages over traditional composite materials and processes for transport fuselage elements. In the current study, design cost modeling relationships between textile processes and element design details were developed. Such relationships are expected to help future aircraft designers to make timely decisions on the effect of design details and overall configurations on textile fabrication costs. The fundamental advantage of a design cost model is to insure that the element design is cost effective for the intended process. Trade studies on the effects of processing parameters also help to optimize the manufacturing steps for a particular structural element.

Two methods of analyzing design detail/process cost relationships developed for the design cost model were pursued in the current study. The first makes use of existing databases and alternative cost modeling methods (e.g. detailed estimating). The second compares design cost model predictions with data collected during the fabrication of seven foot circumferential frames for ATCAS crown test panels. The process used in this case involves 2D dry braiding and resin transfer molding of curved "J" cross section frame members having design details characteristic of the baseline ATCAS crown design.

## INTRODUCTION

A good design represents the best compromise between various reinforcing, competing, and relational variables that interact with the critical requirements. While this concept and related

---

<sup>1</sup> This work was funded by Contract NAS1-18889, under the direction of J. G. Davis and W. T. Freeman of NASA Langley Research Center.

equations that can describe these interactions are understandable, the sheer number results in confusion for the designer. Added to the problem is that the various relationships understood by the different disciplines involved may not always be communicated accurately, usefully or in a time effective manner to influence the design decisions. While the design build team approach improves the design process, personalities, inexperience, and obsolete information can make an optimized design difficult to achieve. In addition, there is currently no real mechanism to understand the various design trades in a timely manner other than by a pass or fail estimation by the design build team members [1]. The fundamental purpose of a design cost model is to allow the various disciplines to communicate their knowledge of how cost interacts with the design details in a timely non-ambiguous fashion such that the best compromise can be reached in the design.

To construct a good cost model it is important to understand and quantify how design and process variables interact with the critical requirements. The first step is to understand the key design features and cost drivers of a particular design/process. The second step involves the formulation of the cost interactions with the design and processing details such that a cost model can be developed. The final step is to calibrate the model based on actual results of real design/process cost interactions.

### KEY DESIGN FEATURES

The identification of the key design features helps to define a structural element or assembly to the cost of manufacturing. This paper focuses on transport fuselage frame elements. The design features for fuselage frames include curvature, cross section, length, gage, and material, shown in figure 1. These features in turn are not at the sole discretion of the fuselage frame designer.

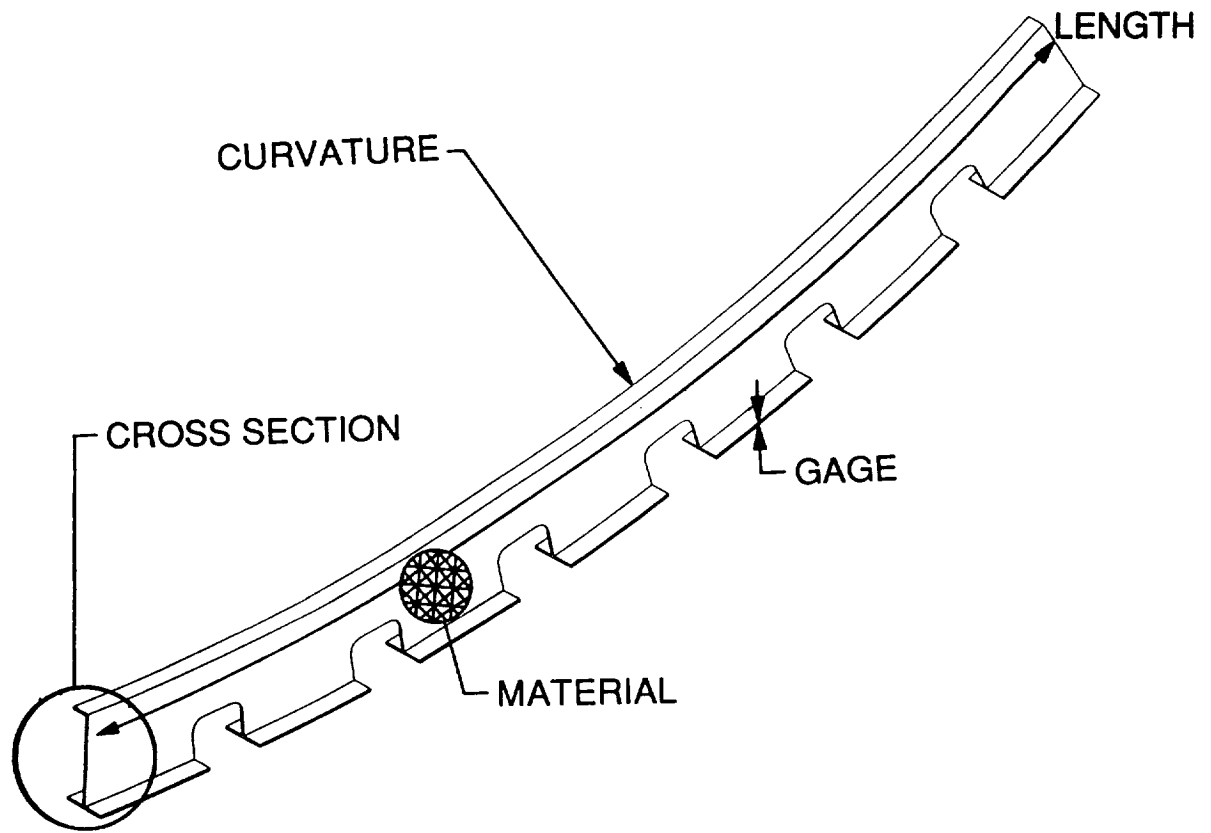


Figure 1. Typical Fuselage Frame

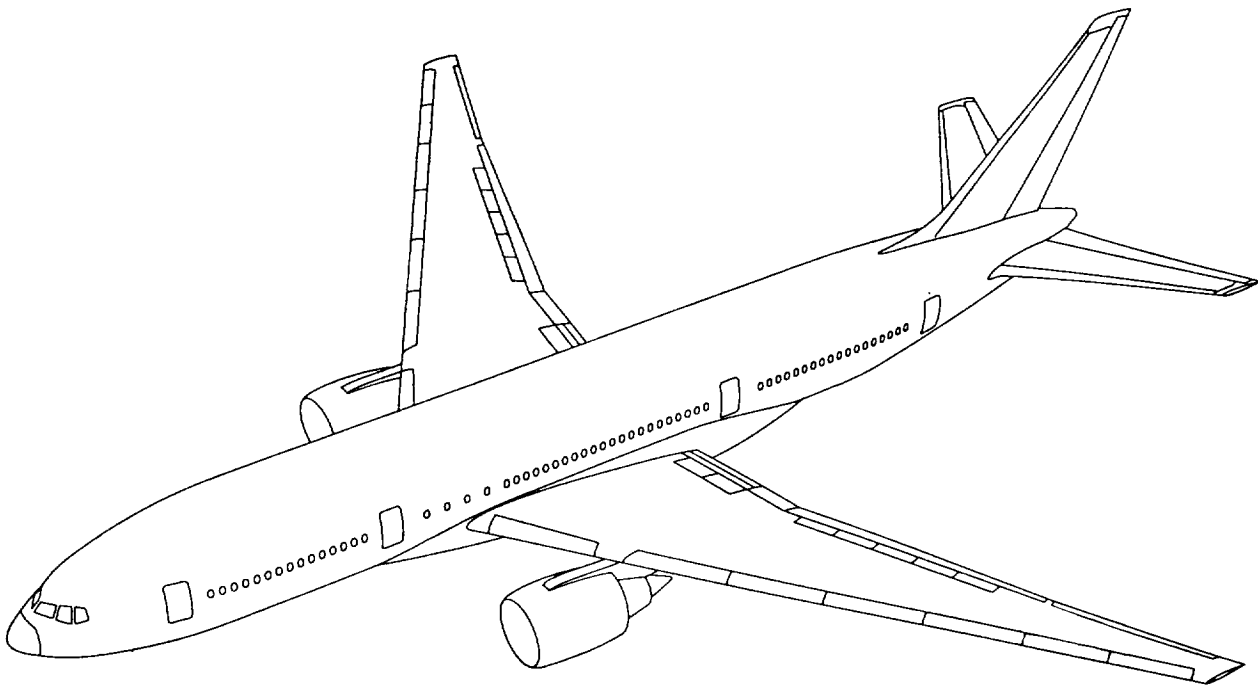
Frame curvature variation is largely a function of the optimum balance between aerodynamic design and required passenger capacity. Frame cross section is influenced by the loads and skin design. Frame length is dictated by manufacturing breaks and cutout locations. Frame gage is a function of loads and manufacturing capability. Frame material selection is driven by design application and manufacturing capabilities.

## KEY COST DRIVERS

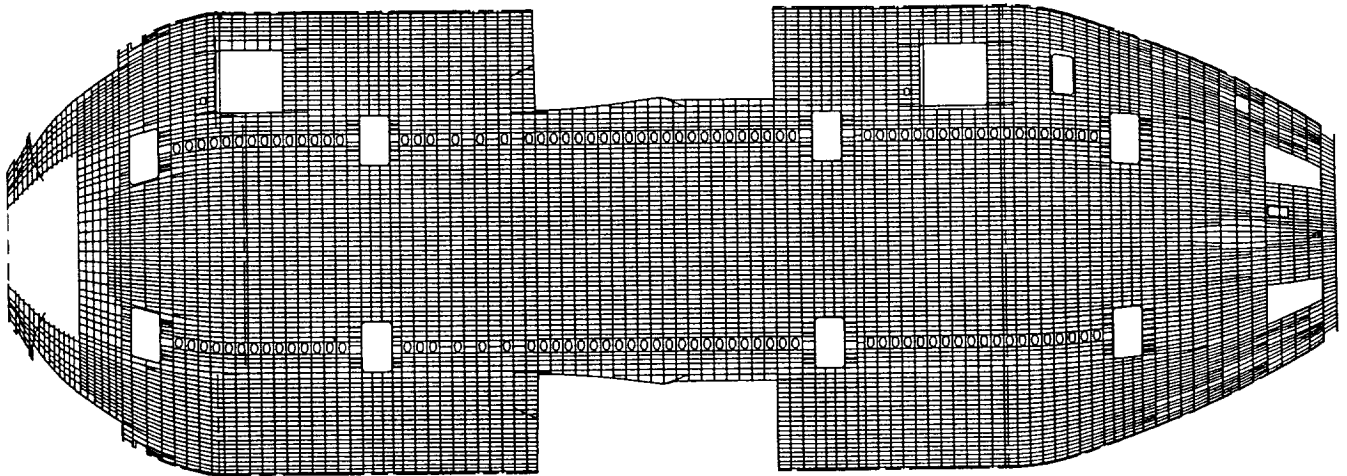
The key cost drivers for fuselage frames include the key design features identified in figure 1. Superimposed on these design features are criteria not normally considered at the design level. Production quantity, production rate, and part commonality can have a strong influence on overall cost. Additional factors to consider include the cost interactions with the manufacturing processes and design features. While individual effects of these variables are reasonably easy to quantify at the process step level, the overall effect on the cost of a complete assemble can be very elusive.

## UNDERSTANDING THE DESIGN ENVIRONMENT

Fundamental to a good cost model is understanding the design environment and the various process and cost interactions with the design details. The first step is to begin to quantify an actual design by the design features. Shown in figure 2 is a typical widebody subsonic transport. Figure 3 represents a skin/stringer/frame layout of a typical widebody commercial transport aircraft. The diagram is produced by essentially splitting the fuselage tube at the lower centerline and unrolling it into a flat pattern.

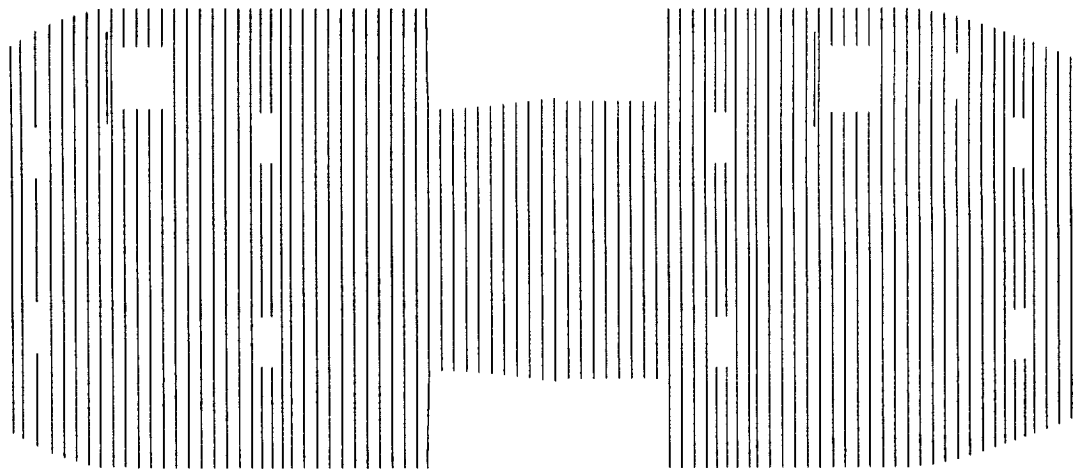


**Figure 2. Typical Widebody Commercial Transport**



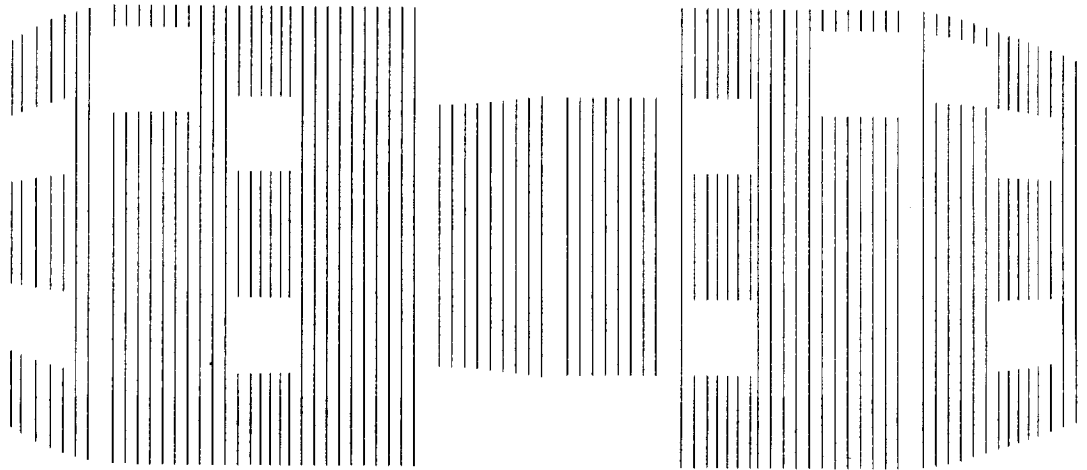
**Figure 3. Skin/Stringer/Frame Layout**

First, all the stringers were removed from figure 3 since the current modeling effort is to focus on just the fuselage frame elements. Secondly, all the fuselage frames aft of the rear pressure bulkhead and in the cockpit area, shown in figure 4, were removed. The frames aft of the rear pressure bulkhead are in a non-pressurized area of the airplane and have fundamentally different design drivers. The frames in the cockpit area, while in the pressurized portion of the aircraft, might be better fabricated using a different method due to the highly complex shape interactions between skin, stringer and frame.



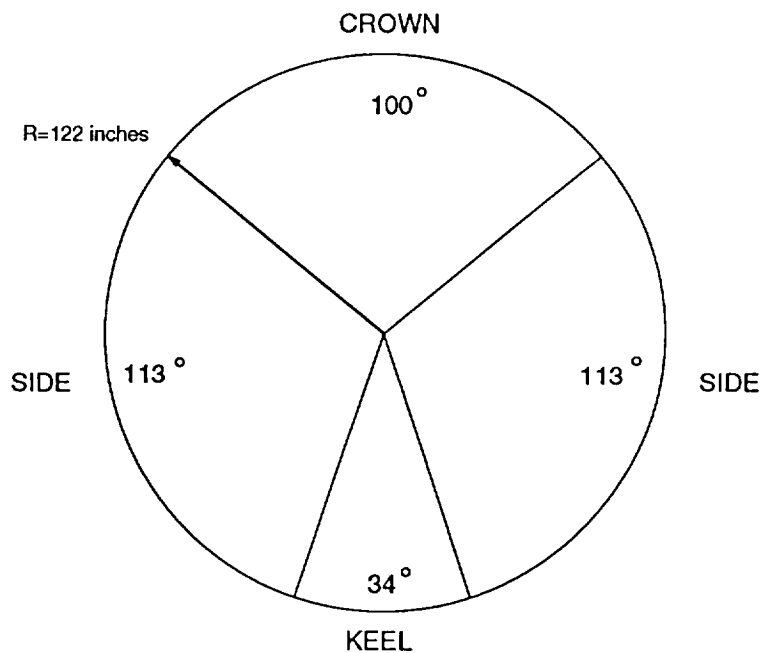
**Figure 4. Fuselage Frame Members**

Further simplification to figure 4 was achieved by removing all fuselage frames around the door areas, see figure 5. The main and auxiliary frame sill design is strongly influenced by the door design and fundamentally different load patterns and damage criteria. It is reasonable to assume that this structure would have different optimal design and fabrication methods. In addition, all major fuselage frame bulkheads, which again have fundamentally different requirements from most fuselage frame members, were removed. What is left are the frames which will be considered in the cost model for relationships between textile manufacturing processes and design details.



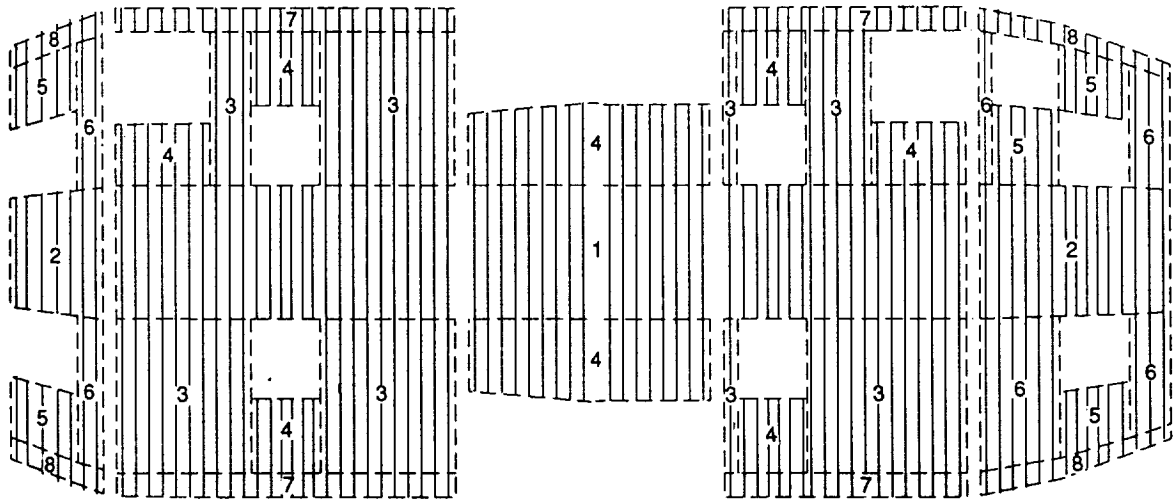
**Figure 5. Fuselage Frames in Study**

The fuselage frames in this study were then grouped by two key design features: curvature and length. The frame length was dictated by manufacturing breaks and cutout locations. The manufacturing breaks used were assumed to be the same as the ATCAS quadrant approach shown in figure 6 [2].



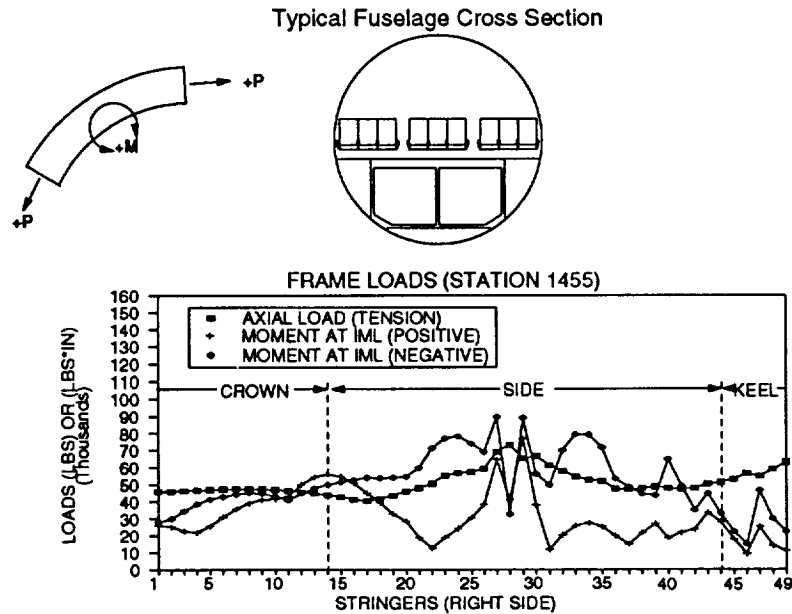
**Figure 6. ATCAS Fuselage Manufacturing Breaks**

Frame curvature was defined by either constant curvature frames or non constant curvature frames. The group of frames by length and curvature are shown in figure 7. This results in eight different frame design groups. Frame design family one would include all frames with similar frame lengths and constant curvature. Frame design family two would include all frames with similar lengths and variable curvature.



**Figure 7. Frame Design Groups by Curvature and Length**

Fuselage frame families were then further subdivided by another key design feature of gage. To determine gage variations within frame family detailed loads were analyzed for load patterns. Depending on the application, composite materials should save weight on the order of 10 to 40 percent. The ability to tailor the frame gage to varying loads will be important in maintaining this margin. Unfortunately, this introduces additional variation into the frame design. There were two methods used to understand load patterns. The first method, shown in figure 8, represents load variation around the fuselage at a typical frame station.



**Figure 8. Frame Fuselage Loads at Station 1455**

The other method used to understand load patterns was load variation in the fuselage frames along the length of the fuselage, shown in figure 9. The axial frame loads show little variation after frame station 1580. Since the positive and negative bending moments remained consistent, this would indicate a frame group categorized by curvature, length and gage.

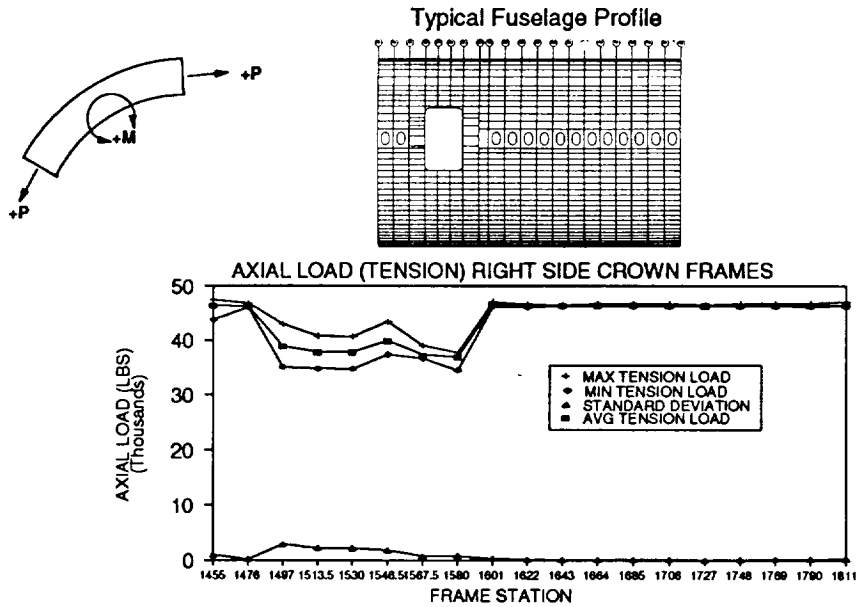


Figure 9. Frame Fuselage Loads Variation by Station

Applying this methodology to all the fuselage frames in the study resulted in the frame design families shown in figure 10 and figure 11. In a typical widebody commercial transport 80% the size of a 747, 19 frame design families were identified. There are 319 frames per airplane with an average length and area of 155 inches and 1.0 in<sup>2</sup> respectively. Using the ACT cost estimating ground rules of 5 airplane/month over 5 years this results in 3350 lbs of graphite/epoxy per airplane or 210,000 lbs/year.

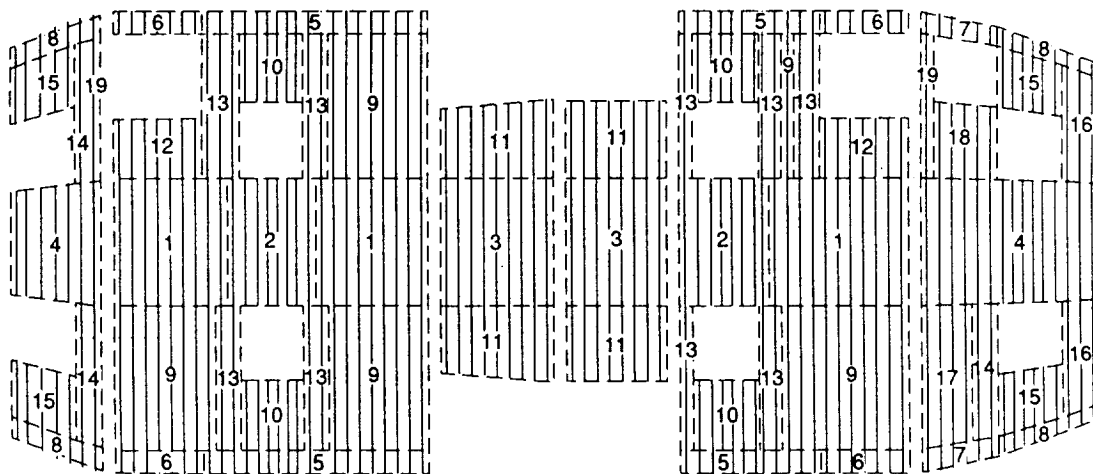
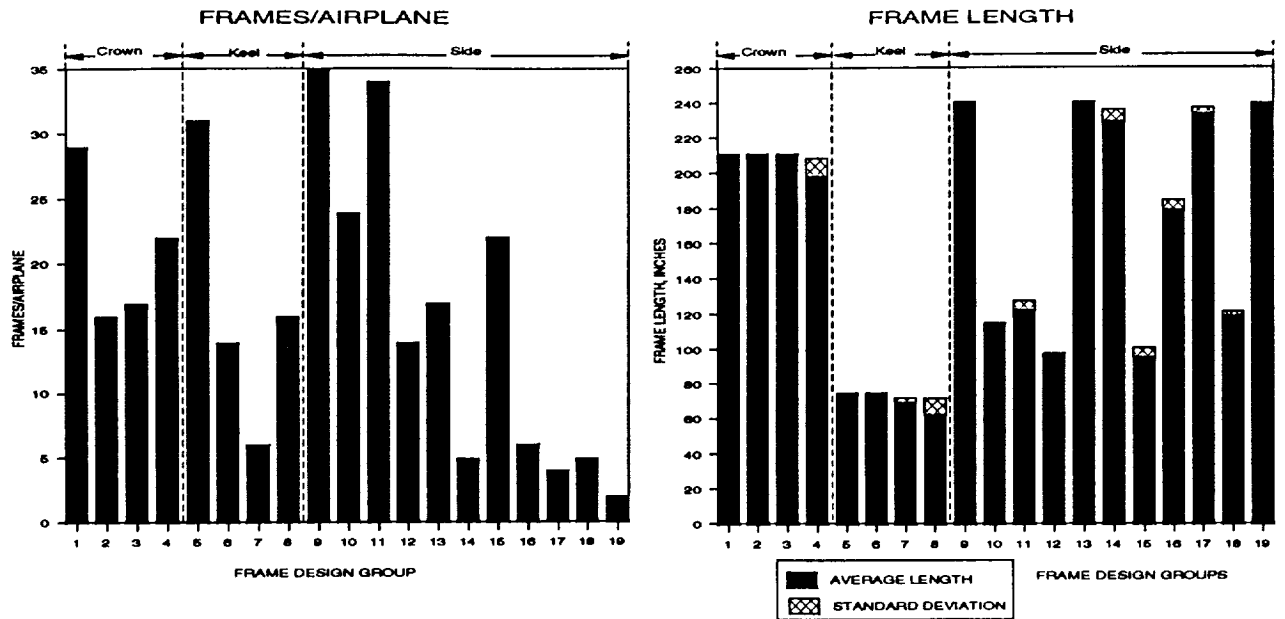
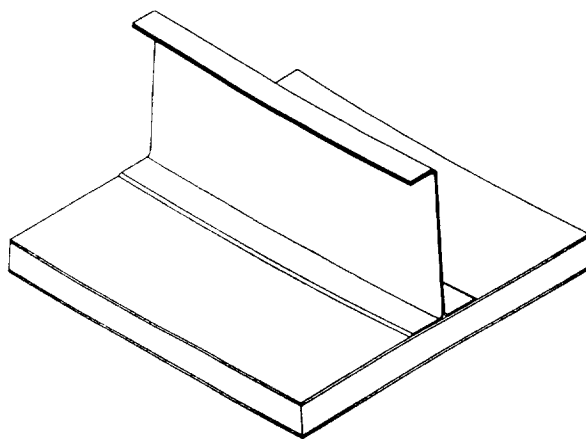


Figure 10. Frame Design Groups by Length, Curvature, and Gage

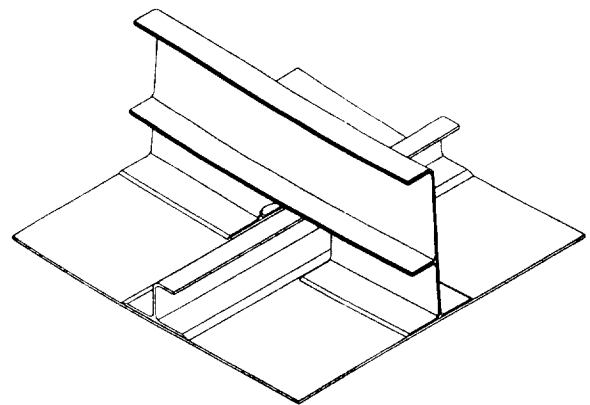


**Figure 11. Frame Design Families**

Superimposed on the frame design families categorized by curvature, length, and gage is the key design feature of cross section. The cross section design is a strong function of the skin design as shown in figure 12. In the stiffened design the mousehole requires the outer flange to be trimmed unlike the sandwich design. If damage were to occur or progress into the skin area under the mousehole the frame would fail due to an applied moment. The additional flange above the mousehole replaces reinforcement that was provided by the undamaged skin.



**"J" Frame Sandwich Design**



**"F" Frame Skin/Stringer Design**

**Figure 12. Fuselage Frame Cross Section Designs**

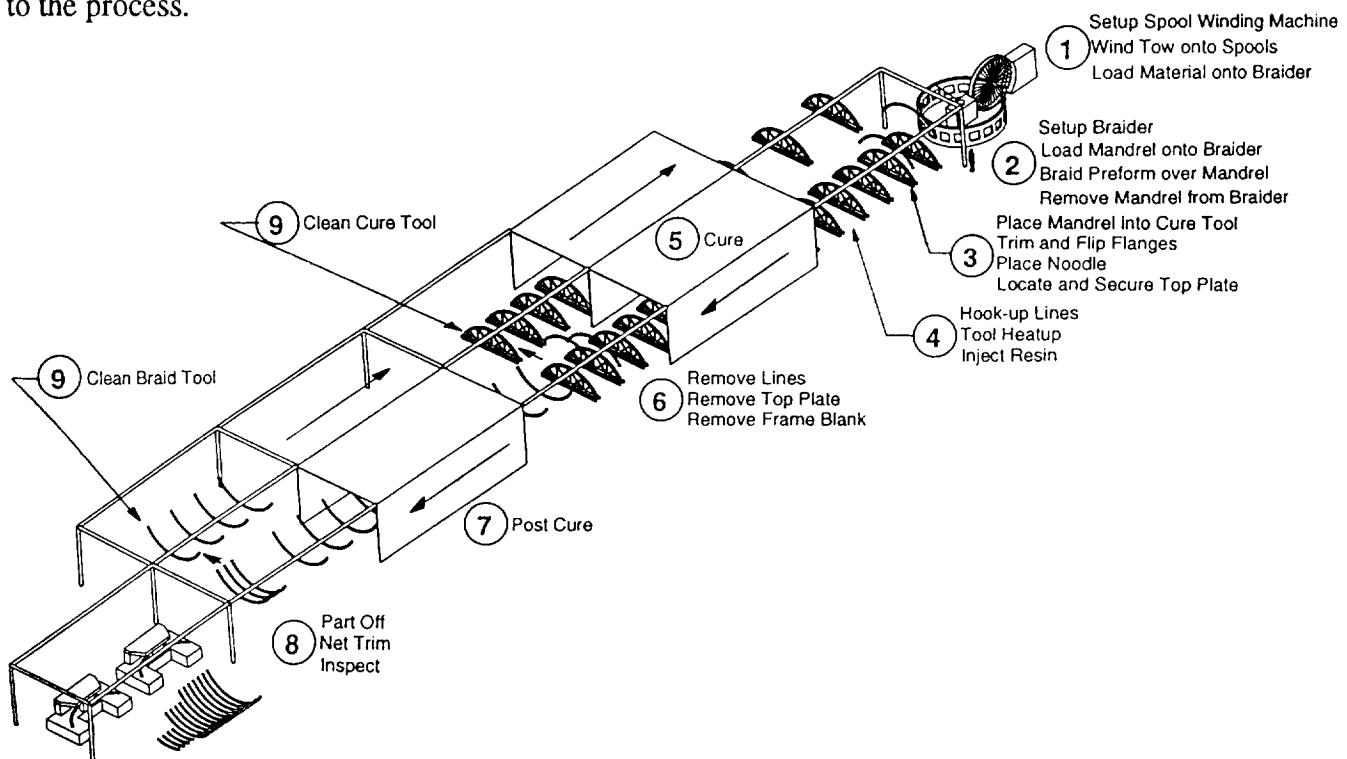


The final key design feature is material. In this study the tri-axial 2D braided AS4<sup>2</sup>/1895<sup>3</sup> material was assumed as the baseline material. Other materials and preforming techniques can be evaluated but would require an analysis model to weigh the relative cost and weight trades [3].

## UNDERSTANDING THE PROCESS ENVIRONMENT

The cost of producing a part is an interaction between the design detail and the intended process. Understanding the processes sensitivities and advantages is essential to evaluating the effects of design features on cost. The braid/resin transfer molding process which was modeled for the current study is shown in figure 13. Each step in the process was modeled with an equation which described cost as a function of the key design features and processing parameters.

The general operating philosophy of this factory layout is that frame design families have many design features that are common. Smaller frames are cut from longer segments (i.e., batched) to help equalize handle requirements. This allows the material handling system to be designed to handle similar size frame blanks. Assembly line techniques comprise an important way of reducing cost. While low commercial aircraft production rates and less part commonality do not encourage production techniques commonly found in the automotive industry, flexibility in the process and grouping common processing steps can significantly improve costs. In this factory layout, the part type specific portion of the process comes in braiding the correct preform to the correctly matched braiding and cure tools. After these steps are accomplished the differences between one frame and the next is transparent to the process.



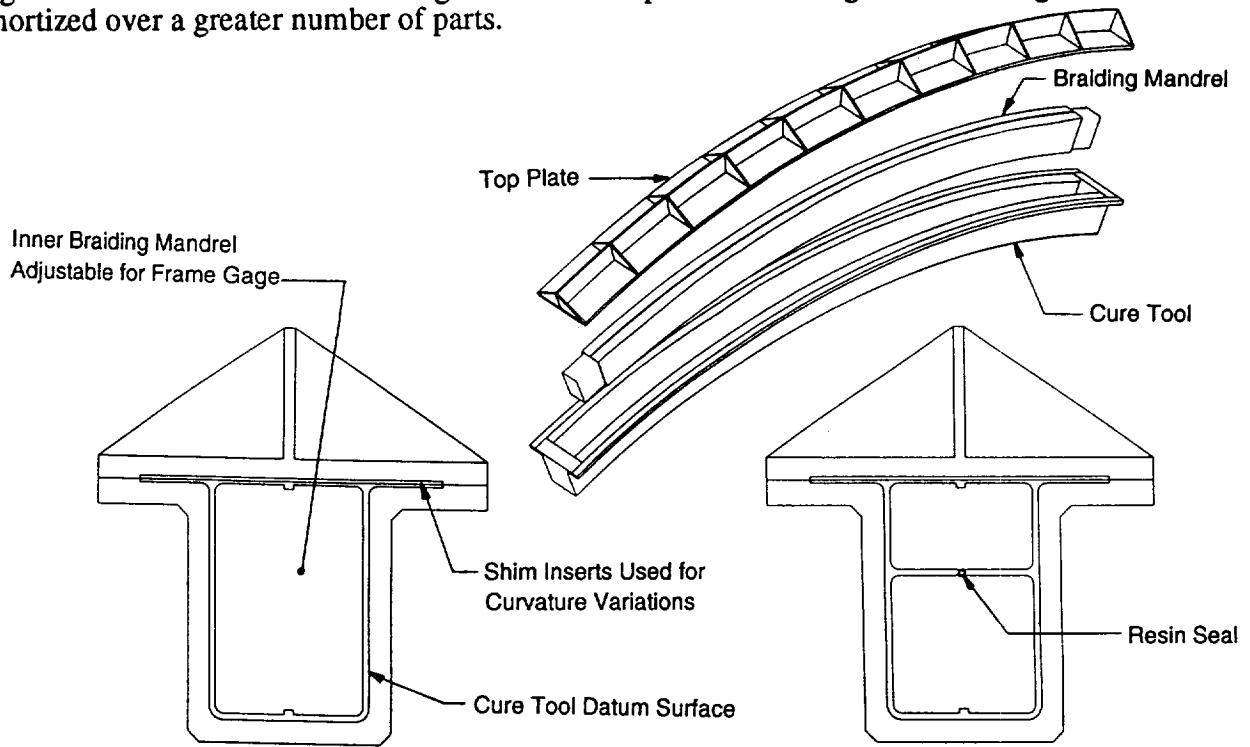
**Figure 13. Braid/RTM Fuselage Frame Factory Flow**

<sup>2</sup> AS4 is a graphite fiber system produced by Hercules, Inc.

<sup>3</sup> 1895 is a epoxy resin system produced by Shell.

Another area of importance to the cost of braid/resin transfer molding processes is the interaction between tooling approaches and the design environment. It should be noted that while 19 frame design families were identified, there can and will be very minor differences between frames within a family which may require a different set of tools. Simply fabricating a different set of tools for every slightly different frame design could render the resin transfer molding process uncompetitive. The key to cost effective tool design is the integration of the tool design to the part design and process flow.

In the process flow, the braiding mandrel follows the part through most of the fabrication cycle. The cure tool, on the other hand, bypasses the post cure cycle and would have an inherently higher utilization rate. It would follow that more braiding mandrels would be required to support the production rate. Therefore, the gage variations could be tailored into the braiding mandrel shown in figure 14. This allows the cure tool to be fabricated as a datum tool. This cure tool could be baselined and fabricated early on in a production program. The braiding mandrel could then be fabricated once the frame design was finalized. Additionally, tooling design should incorporate shim areas such that slight variations between frame designs can be incorporated allowing for the tooling cost to be amortized over a greater number of parts.



"J" Frame Tooling

"F" Frame Tooling

Figure 14. Fuselage Frame Fabrication Tooling Approach

### CALIBRATION OF THE COST MODEL

Once the manufacturing environment and the relationships between design details and cost were understood, the model was calibrated. Two types of data were available to calibrate the model. The first was the detailed estimates done at Boeing for the ATCAS keel and crown design studies. Roughly thirty percent of the Boeing cost estimate is based on labor standards which apply directly to current fabrication methods used at Boeing. The remaining cost data was developed from Manufacturing Research and Development input and extrapolation of existing processes and equipment.

The second source of cost information was actual time studies performed on braided and resin transfer molding fabrication of seven foot "J" frames used on the ATCAS test panels. The comparisons of actual fabrication touch labor and Boeing estimated standard labor, averaged over 300 shipsets, is shown in figure 15. While only the Boeing estimate had learning and variance factors applied, the Fiber Innovations actuals give a good reference point for comparison. With only eight frame fabrication runs available at the time of model calibration, a Boeing estimator judged that it was too early to develop labor standards from the Fiber Innovations actuals. As more actuals are collected the Fiber Innovations curve will be modified in order to apply the Boeing methodology of variance and learning curves over 300 shipsets. This should allow a one to one comparison.

The calibration curve is broken into the nine basic processing steps. Areas where improvements between the process used successfully in an R&D environment and full scale production environment are noted as A through G. The first area involves loading the material onto the braiding equipment. Currently, there are 216 spools on the braiding equipment. Only one third pounds of fiber are loaded per spool. Due to the number of different parts being fabricated and fiber types being used at Fiber Innovations, it would be impractical to load more material per spool. In a production environment where production rate would require dedicated braiding equipment and consistent fiber types, these variations could be eliminated by loading more material onto each spool. This allows for amortization of material load times over more parts, thus lowering the final cost. Loading 2.63 pounds of fiber per spool would allow the braider, in a production environment, to produce frames at a normal operating speed for 70 hours between cleaning and reloading of the braiding equipment.

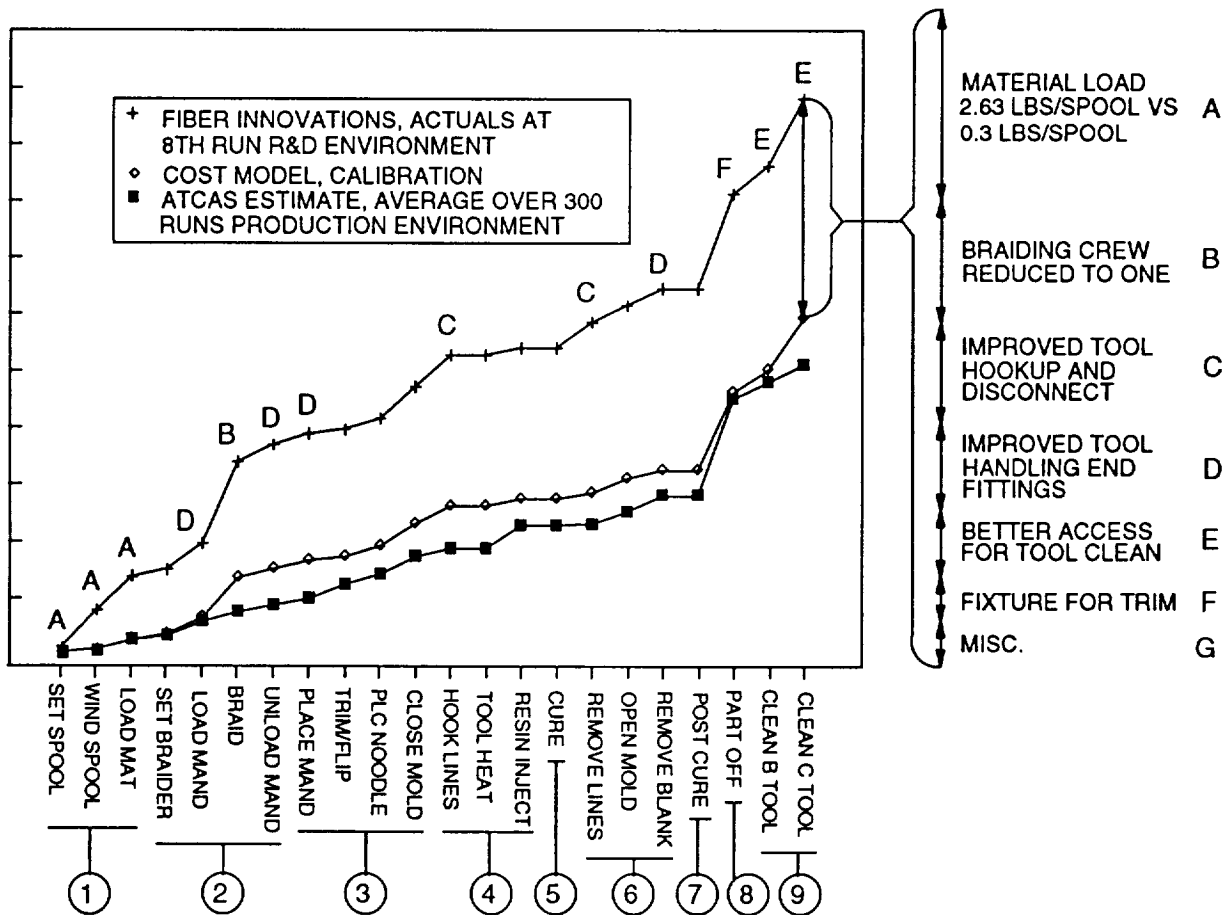


Figure 15. Calibration of Cost Model

The second area of improvement is the number of operators required for the braiding equipment. Two operators are currently used at Fiber Innovations with the second person performing quality control. The ACT cost estimating ground rules require quality control to be accounted as an overhead function. In addition, projected future improvements in braiding equipment could self monitor the braiding process. Therefore it was judged that one operator would be sufficient for the production scenario.

Capital and equipment improvements not justifiable for R&D environments were assumed in place for future frame production. These include improved connectors for hook-up and disconnect of heater, thermocouple and injection lines. Other improvements include tool handling using overhead equipment, optimized factory layout, and improved fixtures. Tool clean in resin transfer molding can be time consuming but improvements in tool design and cleaning methods, such as resin knock outs, can improve labor costs.

## RESULTS

Once the calibration of the cost model was completed the fabrication cost of the various fuselage frame design families could be predicted. There were large cost differences between the various design families largely due to tooling cost differences, shown in figure 16.

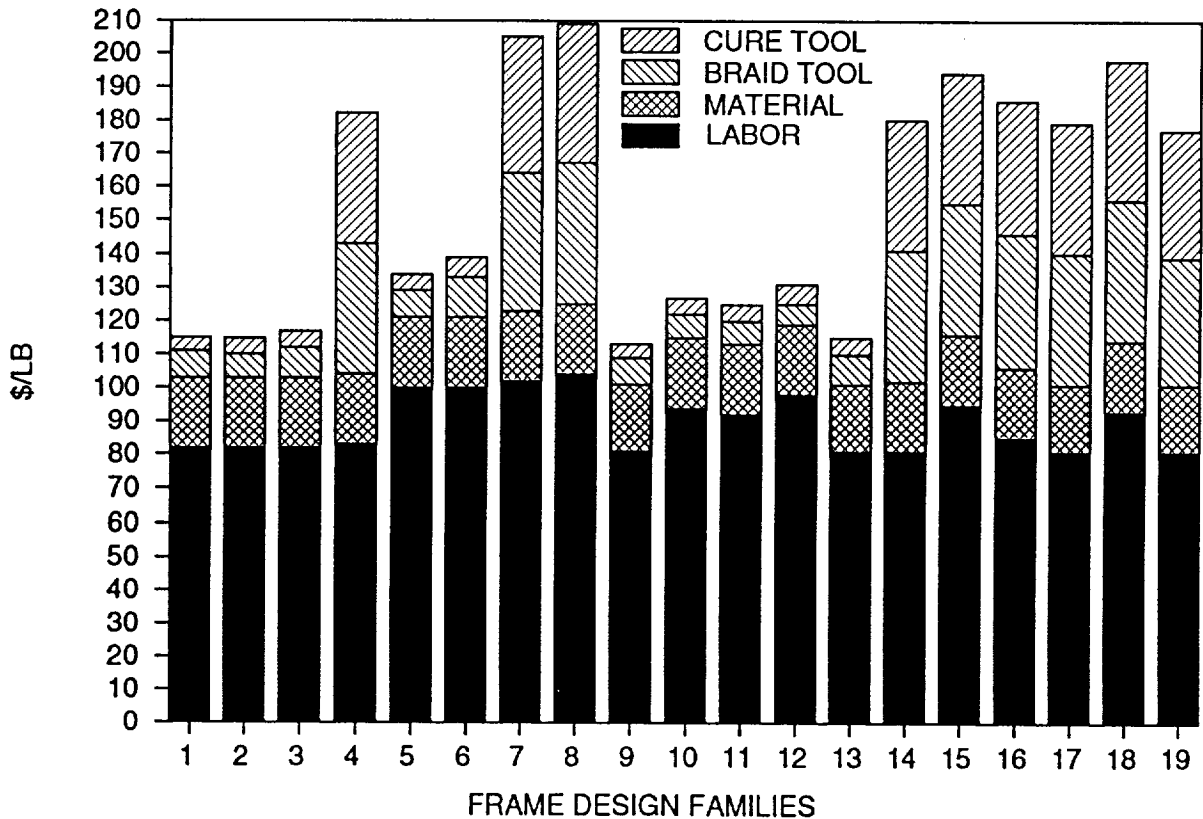


Figure 16. Fuselage Frame Family Fabrication Cost

While the cost breakdown for every family can be identified, the reasons for the differences can be elusive. One of the fundamental reasons for the cost difference between frame design families is tooling. Most of the constant curvature frames did not require any more tooling than was required to support rate. The non-constant curvature frames required a different closed mold tool for every frame. In addition, the quantity of frames in any one design family was not always sufficient to fully utilize the tooling. Frame length can also be seen to have a slight effect on labor costs due to the amortization of setup cost over smaller frames. While this type of information is important it does not allow the designer to find the optimum point between design details and cost. The primary advantage of a cost model is to allow the designer to incrementally vary design details and gain an understanding of how this affects cost.

As shown in figure 17, one strong relationship between cost and frame design details predicted by the model was frame length. Using an average of 17 frames per design family found in the study, frame cost as a function of frame length is plotted. Significant improvements in frame cost were seen for increasing lengths up to about 100 inches. These cost improvements were largely due to amortization of operations in the process which are required regardless of how short the frame is. Superimposed are processing improvements which interact with frame length to allow for the batching of additional frames per tool, amortizing the setup cost over more frames.

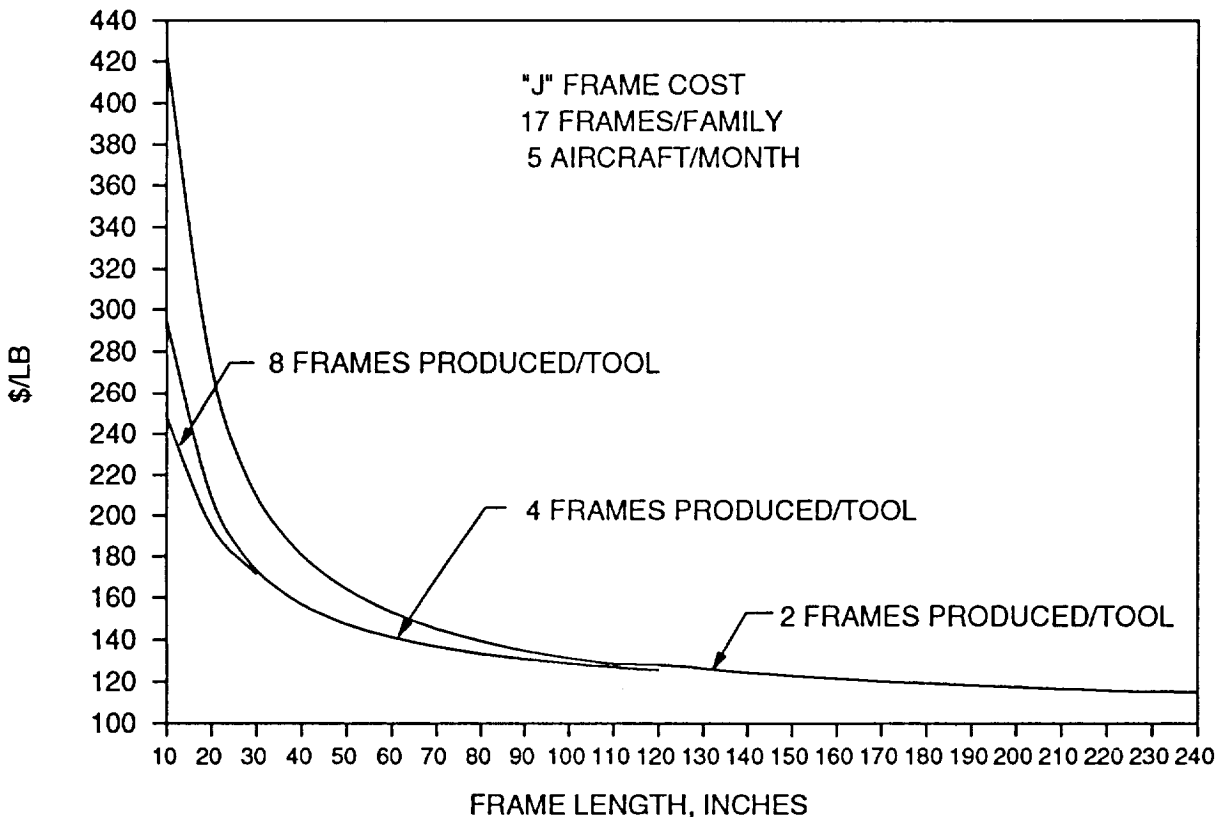


Figure 17. Cost Model Predictions of Frame Cost as a Function of Length

Another strong relationship predicted by the cost model was that of frame commonality. For example, a frame commonality of four would represent an average of four common frames in every frame design family. In figure 18, frame cost versus frame commonality is plotted. As frame commonality increases, frame costs come down and level out at about six frames per family. The leveling out of frame cost is a result of the rate tooling requirement driving the frame cost. Frame commonalities greater than six will not result in any significant advantage in the existing manufacturing environment.

One design detail which can strongly affect frame commonality is frame tailoring to save weight. The cost model would give the designer non ambiguous thresholds for the impact of weight savings versus cost through its impact on commonality. In addition, suppose the optimum cost/weight commonality for fuselage frames is three frames per family. Improvements in unattended cure cycle time would have little impact on frame cost due to the under-utilization of tooling at this frame production rate. If the frame commonality of the design is nine, then improvements in the cure cycle time could improve the frame cost by lowering rate tooling requirements.

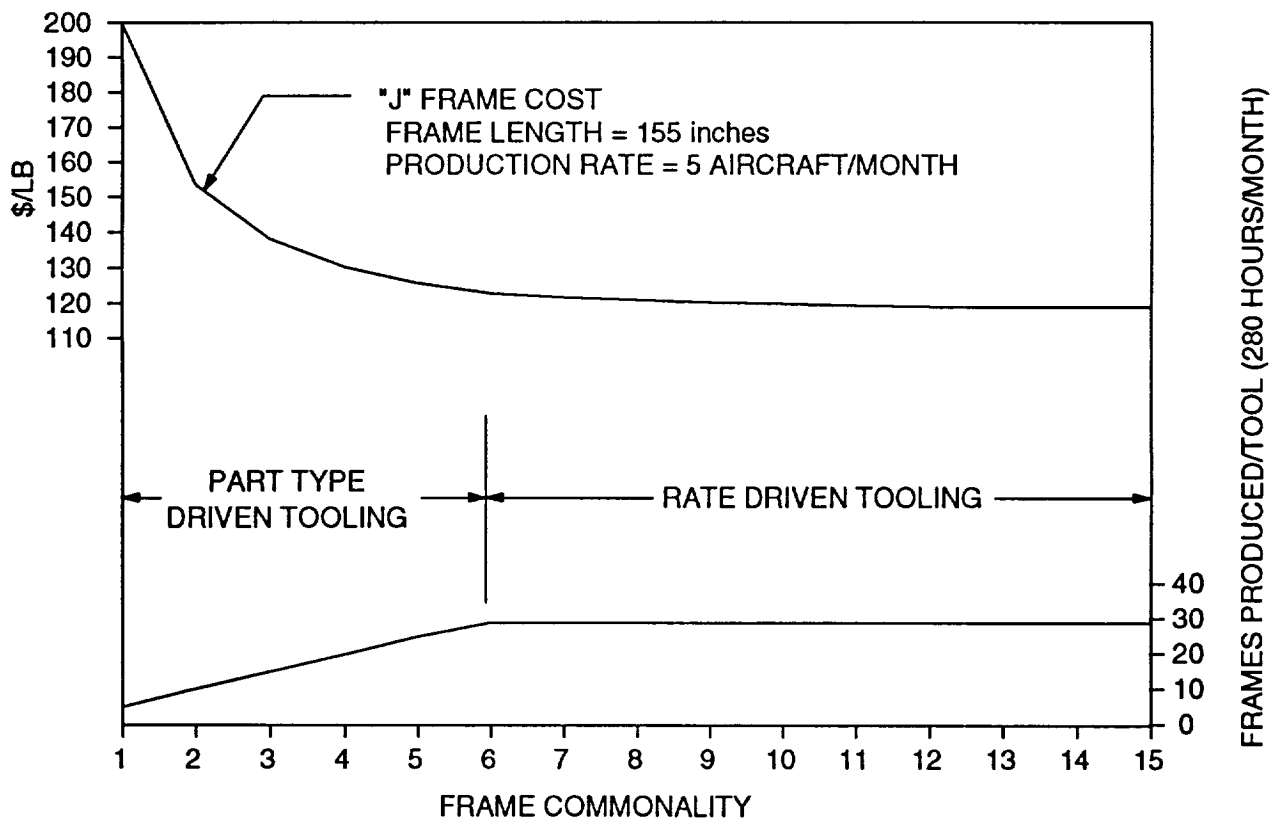
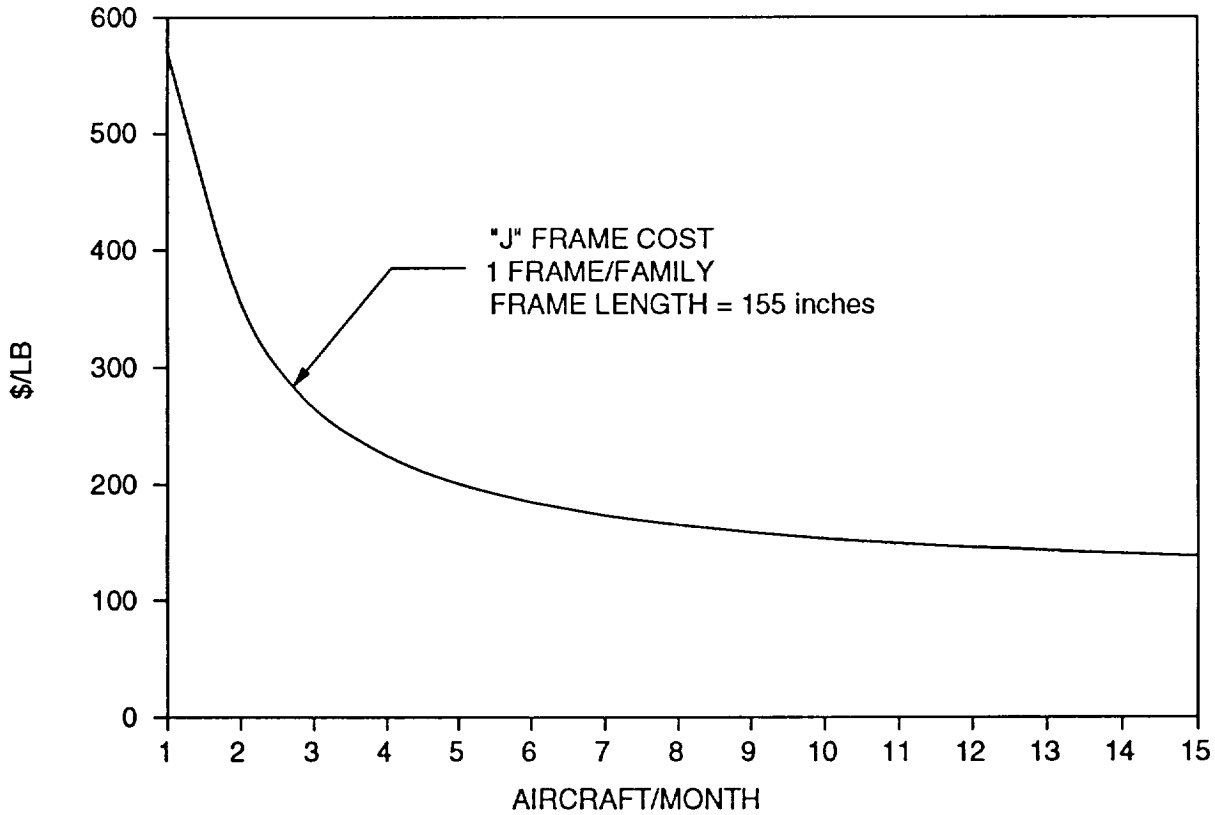


Figure 18. Cost Model Predictions of Frame Cost as a Function of Commonality

Since frame commonality was seen as such a strong driver it follows that aircraft production rate should also be important. The current ground rules used in the ACT program call for a production rate

of 5 aircraft/month over 5 years. Actual production rates can vary between 1 and 21 aircraft/month depending on the aircraft model. Figure 19 shows frame costs versus aircraft production rate. This was also predicted by the model to be strong cost driver, though certainly not at the discretion of the fuselage frame designer.



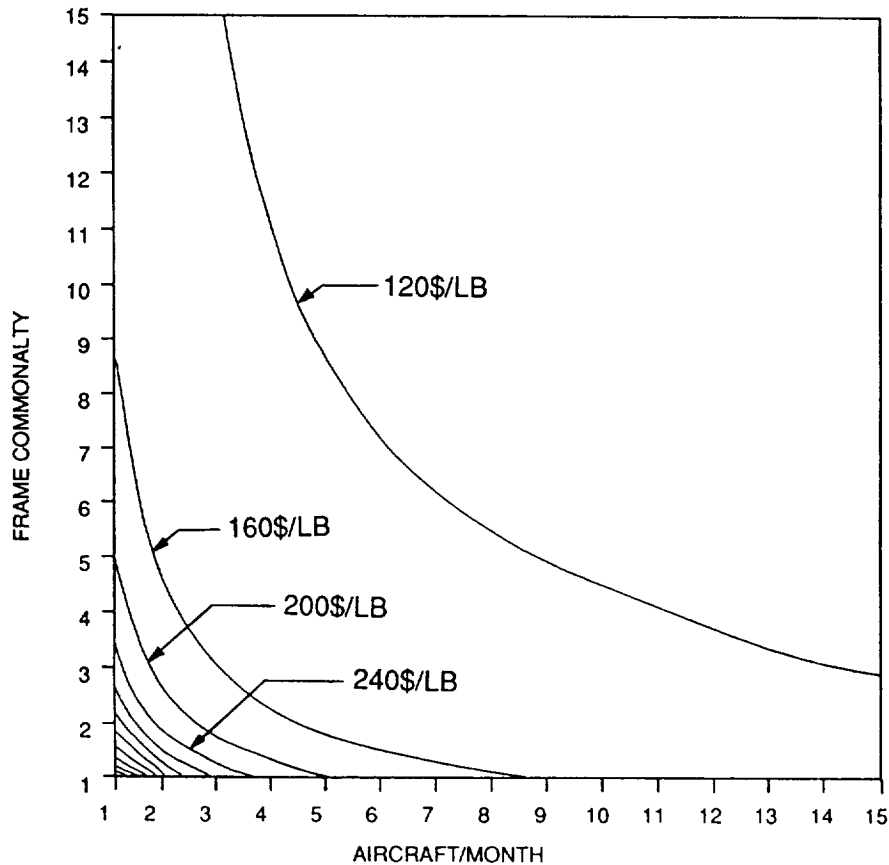
**Figure 19. Cost Model Predictions of Frame Cost as a Function of Production Rate**

The importance of the aircraft production rate with design details only becomes important to the designer through its interaction with the design detail of frame commonality. The graph, shown in figure 20, represents constant frame cost lines as a function of frame commonality and aircraft production rate. For a high production rate aircraft, lower frame commonality would not impact the frame cost as much as a lower rate production aircraft. The cost model would help the designer understand how best to design the fuselage frame detail to allow for the most cost effective application in the baseline production environment. It could also suggest another process be utilized for certain production environments if tied to alternative process models.

The braided/resin transfer molding fabrication process, when applied to fuselage frames, is most cost effective in high production quantities. Whether the higher frame fabrication rate is due to higher aircraft production rates or increased frame commonality does not matter. This is due to the tooling requirements being driven by rate rather than part number variations. Conveying this information to the designer early on could head off production and cost problems which are difficult and expensive to

solve after design release.

In an environment of high production rates braid/resin transfer molding fabrication is cost competitive with other composite fabrication techniques. But more importantly, the cost model prediction, based on actual fabrication labor and tooling costs associated with frames fabricated for the ATCAS test panels, is cost competitive with aluminum fuselage frame fabrication costs. This is in addition to any weight savings through the use of advanced composite materials.



**Figure 20. Cost Model Predictions of Frame Cost as a Function of Commonality and Production Rate**

### CONCLUSION

Important characteristics of a good cost model are to first identify the key features of the design detail. The second step is to develop all cost relationships between the design details and process steps. The third step is to calibrate the model to actual fabrication costs and detailed production estimated costs.

The most important requirement of a good cost model is that it is a flexible communications tool to allow the various disciplines to convey the relationships between design details and cost. No cost



model will be perfect the first time around nor will all possible improvements be known, so flexibility is key. Non-ambiguous and timely communication is the primary problem with the current design optimization process; any worthwhile cost model must address this issue. The last important feature is an open programming architecture such that all the logic from which the cost is derived can be queried and explained. This is very important in preventing any model from becoming a black box to future users, a key failing of past models.

Strong cost drivers predicted by the cost model of braid/resin transfer molding of fuselage frames were frame length, frame commonality, and production rate. When a design environment and production environment are correctly matched, changes in design detail have little impact on cost. When they are not matched significant cost can result. The current study confirms that braid/resin transfer molding of fuselage frames can not only be cost effective versus other advanced composite fabrication methods, but can be on par with detail fabrication costs of metal fuselage frames.

## References

1. Ilcewicz, L. B., T. H. Walker, K. S. Wilden, G. D. Swanson, G. Truslove, and C. L. Pfahl: "Application of a Design-Build-Team Approach to Low Cost and Weight Composite Fuselage Structure," NASA Contractor's Report 4418, 1991.
2. Walker, T. H., P. J. Smith, G. Truslove, K. S. Wilden, K. S. Wilden, S. L. Metschan, C. L. Pfahl: "Cost Studies for Commercial Fuselage Crown Design," In Proceedings of the Ninth DoD/NASA/FAA Conference on Fibrous Composites in Structural Design, Lake Tahoe, NV, FAA Publication, 1991.
3. Fedro, M. J., C. Gunther, F. K. Ko: "Mechanical and Analytical Screening of Braided Composites for Transport Fuselage Applications," NASA Conference Publication 3104, 1990.

*CP-3179*

## **Session IV**

# **DESIGN AND MANUFACTURING OF LOW COST COMPOSITES**

Session Co-Chairmen: Paul Pirrung and Richard Holzwarth  
Wright Laboratory

Papers from this session appear in Volume II, NASA CP-3179

