

522 20  
P 13

# PROSPECTS FOR HIGH ACCURACY TIME DISSEMINATION & SYNCHRONIZATION USING CODED RADAR PULSES FROM A LOW-EARTH ORBITING SPACECRAFT

E. Detoma  
Fiat CIEI Div. SEPA  
Torino, Italy

C. Dionisio  
Alenia Spazio  
Roma, Italy

## 1 INTRODUCTION

The radar (an acronym for radio detection and ranging) is an instrument developed just before the WW-II to precisely measure the position of an object (target) in space. This is done by emitting a narrow pulse of electromagnetic energy in the RF spectrum, receiving the return echo and measuring the time of flight in the two-way path from the emitter to the target. The propagation delay provides a measure of the range to the target, which is not in itself sufficient to uniquely locate the position of the same in space. However, if a directional antenna is used, the direction of the echo can be assessed by the antenna pointing angles. In this way the position of the target can be uniquely determined in space. How well this can be done is a function of the resolution of the measurements performed (range and direction, i.e.: angles); in turn, the resolution will dictate the time and frequency requirements of the reference oscillator.

## 2 ANGULAR RESOLUTION

The angular resolution,  $\Delta\theta$ , of an antenna is a function of its beamwidth and, in principle, for an ideal antenna, is only limited by the laws of diffraction for an electromagnetic wave with a wavelength :

$$\Delta\theta[\text{rad}] = \frac{\lambda}{L} \quad (1)$$

where L is the linear dimension of the collecting area of antenna orthogonal to the direction of interest. For an antenna with a reflector, such as the ones used in radar, L is the linear dimension of the reflector. For a circular reflector,  $\Delta\theta$  is the same for any angle being measured (azimuth and elevation) since the linear dimensions are constant (L is the diameter) along these directions.

For a microwave Real Aperture Radar (RAR) working at X-band ( $f = 10$  GHz,  $\lambda = 0.03$  m), the angular resolution is primarily limited by the size of the antenna; for a 3 meter antenna, the resolution of the angular measurements is roughly  $0.510^{-2}$  rad (0.29 degrees), where the value of provided by eq. (1) has been halved, since the same antenna is used for transmission and reception. At a range of 50 km this translates in a position inaccuracy of about 500 m, which exceeds the ranging inaccuracy of most radars at the same distance. The large beamwidth prevents the microwave radar from being used for imaging purposes if the antenna dimensions are to be kept reasonable.

### 3 INTERFEROMETRIC TECHNIQUES

To overcome this limitation without increasing the size of the antenna, an interferometric configuration can be used instead, where two antennas are receiving the same return echo which is time-tagged with respect to the same time scale. This requires the use of the same frequency reference in the radar receivers in order not to introduce uncalibrated differential phase delays or of two frequency references coherent with each other. This arrangement is the basis of all the interferometric techniques, both for Connected Elements Interferometry (CEI, where the same local oscillator is fed to each element of the interferometric array) or for the Very Large Baseline Interferometry (VLBI, using separate coherent oscillators).

### 4 THE SYNTHETIC APERTURE RADAR

A different scheme was developed when engineers started to develop airborne radars for imaging purposes: the so-called Synthetic Aperture Radar, or SAR for short. In this scheme, the fact that the airborne radar was carried around by an aircraft was exploited, by considering that the same antenna was occupying different positions in space at different times, therefore acting as an array of spatially separated antenna of a large interferometer. These considerations apply only to a stationary target (since the return signals from each of the "virtual" antennas are taken at different times), but for surveying and imaging applications this technique works very well.

When spaceborne radars became a reality, it was easy to translate the SAR concepts in space, with the added advantage of a better stability, uniformity and predictability of the motion of the antenna, since, being bound to an orbiting spacecraft, its position vs. time is precisely set by the laws of the classical celestial mechanics.

In a SAR, the diffraction-limited resolution of a RAR can be improved with signal processing techniques, for example by Doppler-beam sharpening, where use is made of the incremental Doppler shift between adjacent points on the ground to increase the across-range resolution. The Doppler effect can be written (Fig. 1) as:

$$\frac{f_{Doppl}}{f} = \frac{2v \cos \theta}{c} \quad (2)$$

where  $f_{Doppl}$  is the Doppler shift (in Hz),  $f$  is the carrier frequency,  $v$  is the speed of the radar-carrying platform (this may be an aircraft or a spacecraft),  $\theta$  is the angle between the velocity vector  $v$  and the direction of observation,  $c$  is the speed of propagation of the electromagnetic radiation and the factor 2 accounts for the two-way propagation. Since:  $\lambda = c/f$ , eq. (2) can be rewritten as:

$$f_{Doppl} = \frac{2v \cos \theta}{\lambda} \quad (3)$$

By differentiation and neglecting the signs (ref. 1), we can derive the rate of change of the Doppler shift as:

$$\Delta f_{Doppl} = \frac{2v \cdot \sin \theta \Delta \theta}{\lambda} \quad (4)$$

Since the angular change  $\Delta \theta$  is related to the resolution  $R_y$  (see eq. (1) above):

$$\Delta \theta = \frac{R_y}{R} \quad (5)$$

eq. (4) becomes:

$$R_y = \frac{R \cdot \lambda}{2v \cdot \sin \theta} \cdot \Delta f_{Doppl} \quad (6)$$

If  $f_{Doppl}$  is measured down to 10 Hz, considering  $\theta$  close to 90 degrees, the satellite velocity being about 7 km/s and the range around 1000 km, then the  $R_y$  resolution drops to 21.5 m. (See para. 7 for an easy derivation of the satellite velocity in a circular orbit)

## 5 RANGING ACCURACY

The ranging resolution  $\Delta R$  (and accuracy) for a pulse radar is essentially a function of how well the round trip time of the transmitted pulse is measured:

$$\Delta R = c \cdot \frac{\Delta\tau}{2} \quad (7)$$

where  $c$  is the speed of propagation of the electromagnetic wave and  $\Delta\tau$  is the rise time of the received pulse. If the pulse is severely distorted by the propagation effects or by the reflection from the target, then it is better to consider  $\Delta r$  as the full width of the transmitted (received) pulse. For a depression angle  $\phi$  in the ZX plane, the resolution  $R_x$  along the x-axis (Fig. 1) becomes:

$$\Delta R = c \cdot \frac{\Delta\tau}{2 \cos \phi} = R_x \quad (8)$$

## 6 RANGING ACCURACY IN NOISE

From the information theory, for a signal affected by noise, it has been shown (ref. 4) that the accuracy of a time interval estimate is related to two parameters: the signal to noise ratio of the received signal (S/N) and the associated bandwidth BW (see ref. 2, page 5, and ref. 3, page 8):

$$\sigma(t) = \frac{1}{\beta \cdot \sqrt{R_o}}; \text{ and } R_o = \frac{2E}{N_o} \quad (9)$$

where  $R_o$  is the ratio of the peak signal to noise power and  $\beta = \beta_{[2]}$  is the normalized second moment of the signal energy spectrum:

$$\beta_{[2]} = \frac{\int_{-\infty}^{\infty} \left| \left[ \frac{\partial a(t)}{\partial t} \right]^2 \right| \cdot dt}{\int_{-\infty}^{\infty} |a(t)|^2 \cdot df} = \frac{\int_{-\infty}^{\infty} (2\pi f)^2 \cdot |A(f)|^2 \cdot df}{\int_{-\infty}^{\infty} |A(f)|^2 \cdot df} \quad (10)$$

and is a measure of the signal bandwidth. The larger the bandwidth, the better the determination of the time interval that can be obtained from the measurement.

## 7 TIME AND FREQUENCY REQUIREMENTS FOR A SPACEBORNE SAR RADAR

Spaceborne imaging radars are especially useful because of the characteristics of the electromagnetic portion of the spectrum in which they operate<sup>[1]</sup>: the atmosphere is a strongly absorbing medium in the visible and infrared region, especially in overcast or rainy weather, when visible or infrared detectors cannot operate. By providing their own source of radiation, radars can operate at night and penetrate the atmosphere with a smaller attenuation than optical sensors, thereby providing an all-weather imaging capability, even if they are not capable of the same detailed image resolution that can be provided by optical sensors.

The most interesting and diffused active microwave instruments are the Radar Altimeters (RAs) and the Synthetic Aperture Radar (SAR). In the near future, other instruments such as the Rain Observation Radar and the Cloud Radar will be developed and launched. The RA generates three measurements: (1) the height of the spacecraft over the Earth surface, (2) the sea waves standard deviation, (3) the wind speed at the sea surface based on reflectivity measurements. The RAs are nadir-looking instruments, generally operating at Ku-band (13.5–13.8 GHz), transmitting a linearly modulated (chirp) pulse with a typical bandwidth of 320 MHz. The transmitted power varies between 5 and 70 W, depending on the design and the application. The footprint is in the order of 15–20 km with an antenna of 1 m diameter. The interesting characteristic is that this instrument is maintained in operation along all the orbit (altitude:

500 – 1200 km), irrespectively of whether it is designed to track all the globe surface or the oceans only.

The SAR instruments are coherent radars which use the motion of the spacecraft to generate the synthetic aperture to increase the azimuth resolution and produce 2-dimensional images of the Earth surface. Spaceborne SARs are operating in the following bands: L, S, C, X, Ku; the transmitted pulses have bandwidths ranging from a few kHz to 300 MHz. The access area on the ground may vary from 50 km to more than 500 km in the more powerful SARs using steerable antenna beams. The transmitted peak power from a SAR can reach the 3–5 kW with antennas as large as 30 m<sup>2</sup>.

The geometry of RA and SAR electromagnetic illumination of the Earth surface during a typical mission is shown in Fig. 1, where the parameters of interest (access area, swath, height, etc.) are clearly identified. (The swath angle is equivalent to the instantaneous field of view for an optical instruments, defining the size of the image taken by the SAR; however, because of the peculiar technique used by SARs, the swath angle refers only to the across-track dimension of the image.) When we consider a satellite orbiting the Earth at about  $h = 1000$  km of height in a near circular, polar orbit, which is the typical orbit for a remote sensing SAR satellite, the linear velocity [in km/s] of the satellite in the orbit is given by:

$$v = 7.9 \cdot \sqrt{\frac{R}{R+h}} \quad (11)$$

and can be computed to be about 7 km/s, assuming for R (Earth radius) an average value of 6370 km. The orbital period P [in minutes] can be computed as:

$$P = 84.4 \cdot \sqrt{\left(1 + \frac{h}{R}\right)^3} \quad (12)$$

and comes out to be around 100–105 minutes for the previous parameters. On the subsatellite track, the SAR image moves at a linear velocity of about 6.35 km/s. If the image is to be located with a maximum error of 400 m, then the timing accuracy required to precisely correlate such an image to its position on the subtrack is only 63 ms. An overall synchronization accuracy of 5 to 10 ms seems more than justified to satisfy this requirement. However, if the single pixel of the image is to be correlated with its position on the subtrack, since the pixel corresponds roughly to the resolution cell of the SAR (a few meters), then the timing accuracy increases to 0.4 ms, and an overall synchronization accuracy in the range of 50 to 100  $\mu$ s must be achieved. This is generally beyond the capability of the bandwidth and delay stability of the command/telemetry data links, unless use is made of the wide bandwidth data link relaying back to Earth the data acquired by the spaceborne SAR.

The positioning and timing requirements can be easily satisfied with an onboard GPS receiver, but for the sake of providing a complete autonomy to the system, especially desirable if the SAR is used for national security purposes, we have investigated other possibilities to provide such a synchronization. As we are going to show thereafter, one interesting possibility can be provided by the use of the pulses of SAR itself; the possibility is interesting since, besides providing the desired accuracy in the synchronization of the onboard clock, the technique may have other interesting spinoffs.

Frequency accuracy and stability requirements are dictated mainly by the specified resolution of the SAR measurements. To perform good ranging measurements [see eq. (7)], it is important that the onboard frequency reference is stable (a few parts in  $10^{-8}$ ) and accurate for the full duration of the mission (2–3 years typical). Again, a measure of the frequency of the onboard oscillator can be easily derived in terms of time offset measurements (synchronization), if these are taken and recorded over a sufficient interval of time. Furthermore, the short term stability

of the on-board oscillator should be good, to insure a low jitter in the transmission of the pulse and reception of the echo (this can be degraded by the phase noise of the local oscillator), thereby insuring a good precision in the round-trip time interval measurement.

Frequency stability requirements are dictated mainly by eq. (5). Since frequency and time stability are equivalent:

$$\frac{\Delta f}{f} = \text{frac} \Delta t t \quad (13)$$

the short term stability of the oscillator over the round trip time interval (around 7 ms for a 1000 km range) must be capable of allowing the measurement of the rate of change of the Doppler shift: for a 10 Hz frequency resolution at X-band, this turns out to be around  $1 \cdot 10^{-9}$  at a sampling time  $\tau = 7$  ms. The characteristics of radar frequency sources used on operational spaceborne SARs designed by Alenia Spazio are listed in Table 1.

## 8 RANGING RESOLUTION (2-WAY) VERSUS TIMING CAPABILITY (1-WAY)

In order to evaluate the potential of the radar signal to transfer precise time, we must look again at the SAR specifications; for the SAR that we are considering the specified ranging accuracy is in the order of 3 to 10 meters: this translates to one-way time delay accuracies in the order of 20 to 60 ns worst case, since these figures can be further reduced by the consideration that they apply to a two-way measurement, and that for a one-way trip the signal to noise ratio is much, much better (since the RF power decreases as the square of the range and not with the fourth power, and the loss due to the target reflection [effective radar cross section] can be totally neglected).

Table 2 shows a comparison between the SAR and the well known GPS system; the comparison applies to several parameters relevant to the one-way time-transfer accuracy. Even if a full assessment of the capabilities of the SAR technique for time transfer has not yet been completed, nevertheless a quick inspection of the table 2 with reference to eq. (8) shows the potential of the technique.

Obviously, the well known limitations of the one-way technique (propagation delays) still apply, and they remain the main factor in determining the overall timing accuracy of the technique, presently limited by our knowledge of the troposphere and ionosphere behavior (propagation models); dual frequency operation (on new RAs) certainly will improve the ionospheric delay uncertainty by a direct measurement of the ionospheric delay.

## 9 PULSED AND CHIRPED RADARS

Early radars used pulses of RF energy for ranging purposes. While pulsed radars represent the easiest and historically older approach to range determination, since a pulse with a sharp rise time seems an ideal waveform because of its wide bandwidth, yet they suffer from other limitations. Multiple returns or widening of the pulse waveform because of the dispersive characteristics of the medium severely distort a narrow pulse; widening the pulse decreases the accuracy of the measurement. Moreover, the narrow RF pulses make inefficient use of the power available at the transmitter and of the bandwidth of the communication channel, providing a poor RF power density in the frequency domain over the spectrum of interest (the bandwidth BW of the transmitted pulse).

In general, the performance of narrow pulses as a time mark for ranging or synchronization purposes is poor with respect to other systems such as spread-spectrum (SS-PRN: Spread Spectrum Pseudo Random Noise) modulation techniques, nowadays widely used for the above

mentioned purposes. However, the latter method is complicated to implement, requires code synchronization to be acquired and maintained, and for these reasons is not well suited for ranging uncooperative targets, where the S/N ratio can be low, severely limiting the code tracking capability for SS-PRN systems.

Radar technology has developed another technique to overcome some of the previous limitations while making efficient use of the bandwidth available. (This technology is not limited to radars only, but it has been applied also to sonar ranging or to optical (laser) pulse compression.) This makes use of the compression of a wide pulse in the time domain exploiting the peculiar frequency domain characteristics of the pulse itself. The pulse can be compressed using analog (frequency modulation) or digital (Barker codes) methods. The pulse is coded in transmission and compressed when received using properly matched filters. Consider a transmitted pulse of duration  $\tau$ , linearly frequency modulated from  $f_1$  to  $f_2$  at a rate of

$$\frac{f_2 - f_1}{\tau} \quad (14)$$

(see Fig. 2). The received signal is fed to a frequency-dependent delay line, so that the low frequency portion of the spectrum (which is received first in the case shown in Fig. 3) is delayed of a greater amount than the higher frequency components (that are received later). Hence, at the output of the delay line all the components appear at the same time, effectively compressing the RF energy of the pulse in a very narrow interval in the time domain.

The final output is equivalent to a very narrow pulse even if the transmitted, reflected and received waveforms are of considerable duration in the time domain. For the conservation of the pulse energy, the amplitude of the compressed pulse will be higher than the amplitude of the received pulse. This pulse will have a  $\text{sinc}/x$  characteristic, with a maximum value of  $\sqrt{D}$  where  $D$  is defined as the dispersion factor, and is equal  $\tau \cdot (f_2 - f_1)$ . The compression ratio  $K_c$  is the ratio of the transmitted pulse width to the compressed pulse  $\tau_c$ :

$$K_c = \frac{\tau}{\tau_c} \quad (15)$$

Therefore, a one microsecond pulse with  $K_c = 100$  yields a compressed output pulse of 10 ns, with a range resolution capability of 1.5 m. A modern spaceborne SAR may work with higher values of  $K_c$ : typically, a 100  $\mu\text{s}$  pulse will offer the same level of performance with  $K_c = 100000$ , the main limitations being the capability to linearly modulate the transmitted pulse with minimum deviation from linearity, the phase delay flatness of the receiver and the linearity of the receiving delay line.

## 10 TIMING USE OF THE CHIRPED PULSE

The most common techniques to synthesize digitally a waveform include methods where samples of the waveform are precomputed and stored (typically in RAM), or where the values of circular functions (sine, cosine) are stored in memory (look-up table). The second approach offers many advantages: a signal wider bandwidth and higher center frequency, a reduction in the hardware complexity if different waveforms have to be generated, etc. The key element is the Numerical Controlled Oscillator (NCO) which, under external control, generates time-discrete sinusoidal samples (see Fig. 4). With an NCO-approach to the chirped pulse generation, the waveform can be modulated easily in amplitude (again, using a digital control or in analog form by acting on the reference voltage of the Digital-to-Analog Converter [DAC, see Fig. 4]), frequency or phase. Phase modulation, for example, will not disturb the frequency characteristic of the chirped pulse, while providing a mean to convey data superimposed to the RF carrier within the pulse width.

Working with a 100  $\mu\text{s}$  pulse at X band will provide a considerable time interval and bandwidth ( $\approx 300$  MHz) to superimpose data to the RF carrier in the pulse, using a suitable modulation

method. For instance, the data can be modulated in amplitude, frequency or phase on the chirped pulse, and recovered on reception prior the pulse compression. Alternatively, the synchronization data can be transmitted in dedicated pulses within the radar Pulse Repetition Period, without modifying the normally transmitted pulse.

If the information being coded includes the spacecraft position and time of transmission, then all the elements required to a one-way synchronization are present, and the pulse can be readily exploited for this purpose. The position of the spacecraft can be directly given in terms of its X, Y and Z coordinates in a suitable reference system; these can be provided by the onboard orbit processor or by a GPS receiver, if available. Alternatively, the spacecraft orbit elements can be transmitted, and the spacecraft position at the time of transmission computed on the ground. However, it is likely that future SAR spacecraft will compute their position with high accuracy in orbit, therefore the X, Y, Z coordinates will be directly available for transmission, minimizing the complexity of the ground equipment. The spacecraft local time scale will provide the time of transmission with adequate resolution, and this in turn can be referenced to UTC on the ground via the same synchronization technique.

## **11 SYNCHRONIZATION VIA THE CHIRPED PULSE**

The simplicity of the ground receiver, the high level of the receivable signal and its associated good S/N ratio make the method extremely attractive for very low cost synchronization and time dissemination. The user on the ground needs only to receive the transmitted pulses when the spacecraft orbits overhead. Since the level of the received pulse can be very high, the RF part of the receiver can be simple. The high frequency used limits the effects of the ionospheric delay and the tropospheric delay can be modeled or minimized using signals only when the satellite is at high elevation.

In the receiver, the received signal is split in two (see Fig. 5): one part is fed to the frequency-dependent delay line for pulse compression and range measurement; the other is fed to dedicated circuitry to extract the data coded on the pulse (spacecraft position and time of transmission message): these are used to recover the range information and, knowing the receiver position, to compute the synchronization offset.

If the user position is unknown, the system will allow some capability to precisely locate the user itself, with a method based on successive range measurements from the same satellite, as the satellite moves across in the sky in its orbit: this is exactly what was intended when the U.S. Navy TIMATION project was started many years ago. But navigation or positioning is not the purpose of the technique, however.

Since the synchronization result is just the offset between a ground clock and the spacecraft clock, the method can be inverted to obtain just what we were aiming for: a precise synchronization of the spacecraft clock to a ground reference (namely UTC) and a strict correlation of time and position of the spacecraft.

## **12 SAR SPACECRAFT PASSIVE RANGING**

Reversing the concept, we can use a limited array of ground antennas (3 to 4) in an interferometric configuration (CEI) to track the spacecraft itself with very high accuracy, providing the results of the orbit parameters determination to the onboard orbit processor via the command uplink. Four simultaneous ranges to four separate antennas whose location is known will provide the spacecraft position and the time offset of the onboard clock with respect to the ground references. In this way, the operation of the SAR satellite will be completely autonomous and independent of other navigation systems.

## 13 GEODETIC APPLICATIONS FOR THE PROPOSED SYSTEM

The system is capable of some interesting applications in other fields, notably in geodesy for crustal dynamics monitoring. Slight movements of the Earth crust can be precisely measured by an array of receivers tracking the orbiting SAR spacecraft. The low cost of the receivers and the high precision ranging and timing capability of the system make the technique suitable to implement large arrays over wide areas at reasonable cost. We have considered also the fact that, being a SAR satellite (usually on Earth observation satellite) in or near a highly inclined polar orbit, the system provides good coverage also of the polar regions, where the GPS satellites visibility is impaired by the GPS orbit inclination.

## 14 CONCLUSIONS

Spaceborne remote sensing Altimeters and Synthetic Aperture Radars (SARs) require a highly stable oscillator onboard and good synchronization for return echoes identification and SAR data processing. Therefore, one of the requirements in designing their onboard timing subsystem is to provide a precise synchronization to some ground reference, namely UTC, in order to precisely correlate the pulse time to the spacecraft position.

While this can be provided via the Navstar Global Positioning System (GPS), the capability exist to have an independent mean of synchronization using the transmitted radar pulse as a precise timing reference mark. The large bandwidth and extremely good signal to noise (S/N) ratio of the pulse received on the ground makes this approach extremely appealing for high-accuracy one-way time dissemination and synchronization.

The technique provides additional benefits, besides synchronization, in supporting the mission of the spacecraft. In fact, a small network of 3 to 4 ground receivers, operating as a Connected Elements Interferometer, may provide high accuracy tracking and position determination of the spacecraft for ranging and orbit determination by receiving and processing the same coded pulses. While synchronization and orbit determination can be supplied by an onboard GPS receiver, the proposed technique provides a high precision solution, in principle independent from GPS, to synchronize ground systems to the onboard clock and vice versa, extending the range of applications and possible users for the spacecraft and its instruments. The implementation is extremely attractive because of the low cost, since all the required components for the synchronization/ranging link are already available, but for the coding of the transmitted pulses.

In this paper we have presented a preliminary description and analysis of the potential of the technique to provide an alternative source of high precision timing to demanding users and a survey of the possible applications. Work is now in progress towards a full feasibility study aimed to evaluate the possibility to implement this concept on an advanced spaceborne SAR sensor being proposed by Alenia Spazio.

## 15 REFERENCES

- [1.] S.A. Hovanessian, "*TACTICAL USES OF IMAGING RADARS*", Microwave Journal (February 1984), pp. 109-123
- [2.] E.Byron, G.P.Gafke, J.W.McIntyre, "*PHASE I STUDY AND DESIGN OF TECHNIQUES FOR PRECISE TIME TRANSFER VIA THE TRACKING AND DATA RELAY SATELLITE SYSTEM (TDRSS)*", The Johns Hopkins University, Applied Physics Laboratory Special Report CSC-O- 322 (September 25, 1976)
- [3.] D.K. Barton, H.W. Ward, *HANDBOOK OF RADAR MEASUREMENT*, Artech House Inc. (1984)



- [4.] P.M. Woodward, PROBABILITY AND INFORMATION THEORY WITH APPLICATIONS TO RADAR, Pergamon Press (1957)
- [5.] C. Elachi, SPACEBORNE RADAR REMOTE SENSING: APPLICATIONS AND TECHNIQUES, IEEE Press (1988)
- [6.] S.A. Hovanessian, INTRODUCTION TO SENSORS SYSTEMS, Artech House (1988)
- [7.] Z. Borgarelli, R. Cortesini, C. Dionisio, "DIGITAL CHIRP GENERATOR SUITS SPACE APPLICATIONS", Microwaves & RF (June 1993)
- [8.] F. Nirchio, B. Pernice, L. Borgarelli, C. Dionisio, R. Mizzoni, CASSINI RADAR RADIO FREQUENCY S/S: DESIGN DESCRIPTION AND PERFORMANCE EVALUATION, JGRASS '93
- [9.] G. Angino, C. Dionisio, F. Rubertone, ERS-1 RADAR ALTIMETER SYSTEM DESCRIPTION, JGRASS '91

**TABLE 1: Examples of SAR reference oscillators characteristics**

| Parameter                | ERS-1 R<br>(STALO)        | CASSINI<br>radar                              | X-SAR                     | ASAR  |
|--------------------------|---------------------------|---|---------------------------|---|
| Frequency*[GHz]          | 7.35                      | 12.96   | 8.415                     | 5.331   |
| Aging                    | $\pm 2$ [ppm/2yrs]        | $\pm 0.2$ [ppm/yr]                            | $\pm 7$ [ppm/yr]          | $\pm 1$ [ppm/4yrs]<br>$\pm 0.001$<br>[ppm/100minutes] |
| Temperature drift[ppm/T] | $\pm 20/45^\circ\text{C}$ | $\pm 0.4/55^\circ\text{C}$                    | $\pm 10/50^\circ\text{C}$ | $\pm 0.04/50^\circ\text{C}$                           |
| Power level [dBm]        | 1                         | 11  | 0                         | 3   |
| Harmonics [dBc]          | < -50                     | < -50   | < -60                     | < -60   |
| Spurious [dBc]           | < -60                     | < -60   | < -60                     | < -60   |
| Initial accuracy,        | $\pm 1$                   | $\pm 0.02$                                    | $\pm 1$                   | $\pm 1$   |
| Frequency [ppm]          |                           |   |                           |   |
| Short term stability     | -                         | $5.3 \times 10^{-13}$<br>$\tau = 1 \text{ s}$ | -                         | $2 \times 10^{-11}$<br>$\tau = 7.5 \text{ ms}$        |
| Phase noise [dBc/Hz]#    | < -105 (f=1 kHz)          | < -85 (f=1 kHz)                               | < -95 (f=300 Hz)          | -   |

\*RF carrier frequency [transmission frequency]

#f=Fourier frequency

**TABLE 2: Comparison of parameters relevant to the one-way synchronization between GPS and a SAR system**

| Parameter    | GPS            | SAR                             | Comments  |
|--------------|----------------|---------------------------------|---|
| RF Carrier   | 1.2, 1.5 GHz   | 10 GHz*                         | Ionospheric delays are smaller for higher RF carrier frequencies                                    |
| RF Bandwidth | $\pm 10$ MHz   | $\approx 300$ MHz               | Available Bandwidth*  |
| RF Power     | $\approx 10$ W | $\approx 1 \div 5$ kW           | Determines the (peak) S/N on reception*   |
| Height       | 20000 km       | 1000 km                         | Determines the S/N on reception*  |
| Modulation   | Spreadspectrum | Chirped pulse                   | GPS modulation is more efficient in making maximum use of available bandwidth and link power budget |
| Orbit        | Inclined       | Polar                           | Coverage of polar regions for geodesy purposes is possible with the SAR concept                     |
| Availability | Continuous     | About 4 $\div$ 6 passes per day | SAR in polar orbit does not provide a continuous coverage   |

\*See eq. (8)

\*The sample figure refers to an X-band SAR

FIGURE 1: SAR Concepts

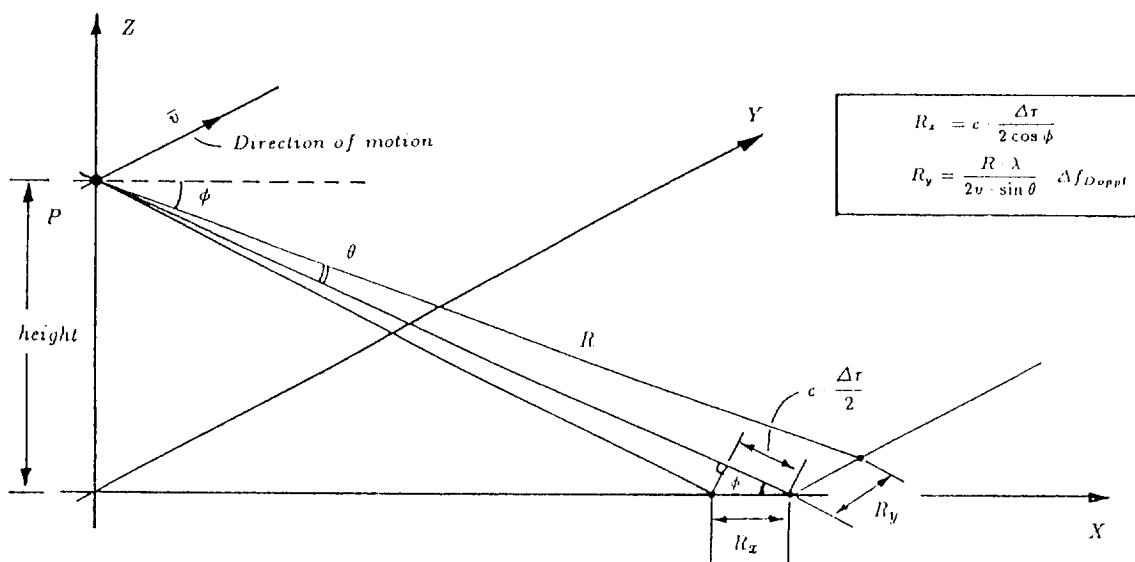
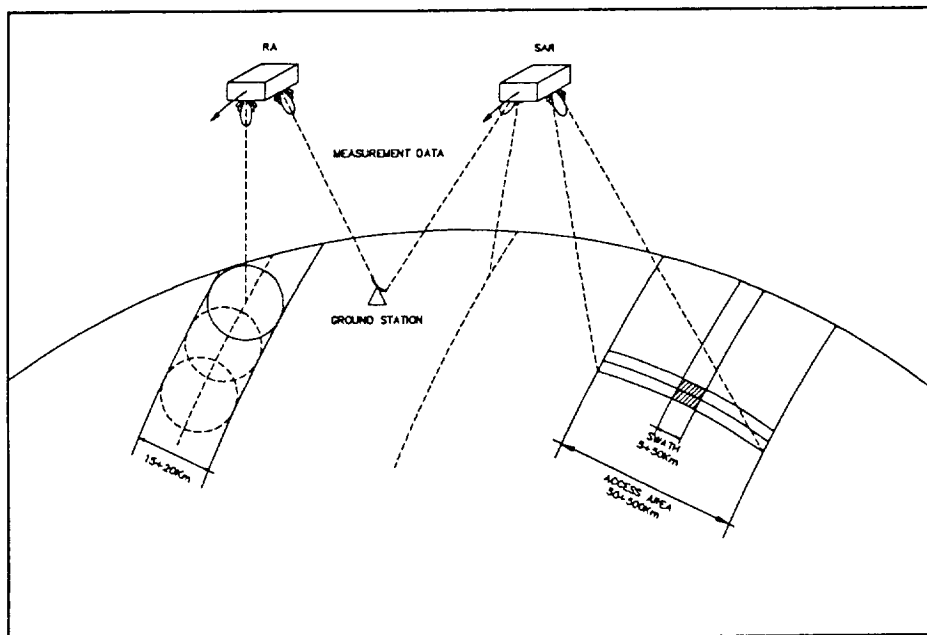

SAR GEOMETRY AND X-Y RESOLUTION

**FIGURE 2: Transmitted waveform of a linear FM pulse (chirp)**

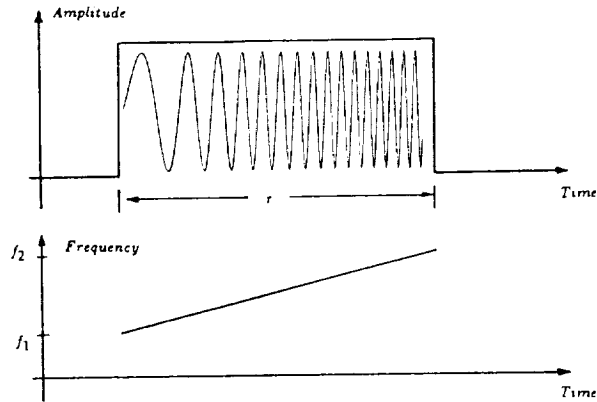

**FIGURE 3: Received waveform of a FM pulse and pulse compression**

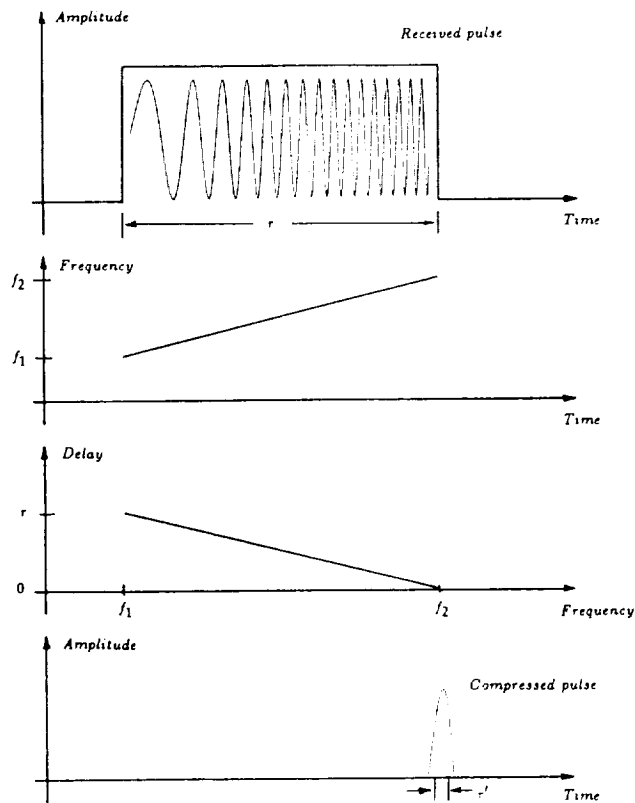

**FIGURE 4: Digital Chirp Generator (DCG) block diagram**

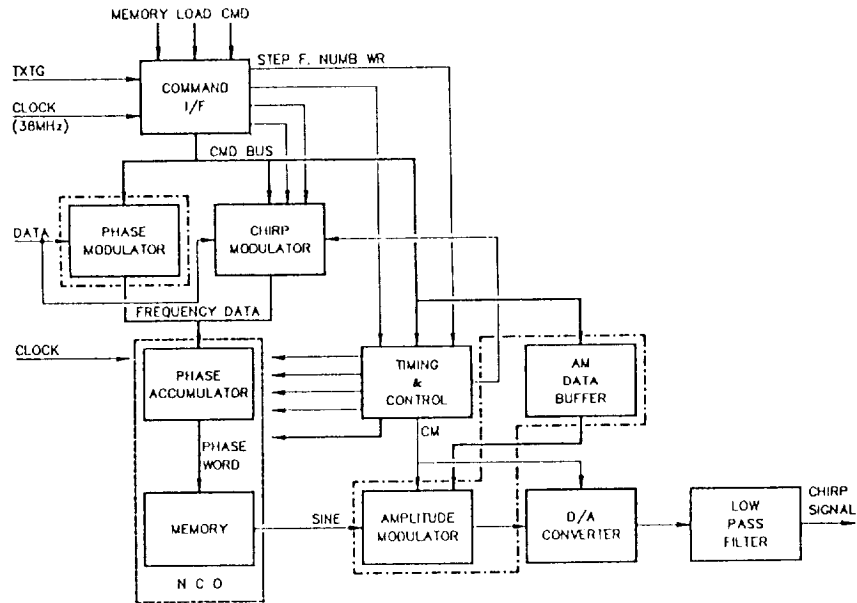

**FIGURE 5: Ground Timing Receiver block diagram**

