

11-26-72
0.17
61033
p. 72

Final Report

submitted to

**NATIONAL AERONAUTICS AND SPACE ADMINISTRATION
GEORGE C. MARSHALL SPACE FLIGHT CENTER, ALABAMA 35812**

May 1, 1995

GRISWOLD
COLOR ILLUSTRATIONS
8

for Contract NAS8-38609

Delivery Order 113

entitled

**Study of the Space Environmental Effects on
Spacecraft Engineering Materials**

by

**Susan K. O'Brien
Research Associate**

and

**Gary L. Workman
Principal Investigator**

**Guy A. Smith
Sr. Research Associate**

N95-32581

Unclas

G3/25 0061033

**Materials Processing Laboratory
Center for Automation & Robotics
University of Alabama in Huntsville
Huntsville, AL 35899**

(NASA-CR-199090) STUDY OF THE
SPACE ENVIRONMENTAL EFFECTS ON
SPACECRAFT ENGINEERING MATERIALS
Final Report (Alabama Univ.) 72 p

TABLE OF CONTENTS

1.0 INTRODUCTION.....	1
2.0 LONG TERM UV RADIATION STUDY.....	1
2.1 Sample Holder Re-design	4
2.2 Spectral Calibration of the UV Light Source.....	4
2.2.1 Results	5
Table: (Excel spreadsheet describing Spectral Radiometer scans taken.)	6
2.3 Contamination Free Verification	8
2.3.1 Solvent Cleaning of the Vacuum System.....	8
2.3.2 Glow Discharge Cleaning of the Vacuum System	10
2.3.3 Results	18
2.4 Long Term Study Experimental Procedures.....	23
2.4.1 Evaluation of Spacecraft Materials	24
3.0 LPSR STANDOFF STUDY	45
3.1 Experimental Procedures	45
3.2 LPSR Sample Standoff Study Results.....	46
4.0 CONCLUSIONS.....	55
Appendix.....	57

INDEX OF FIGURES

FIGURE 1. COMPARISON OF THE SOLAR ABSORPTIVITY FOR CHROMIC ANODIZED ALUMINUM AFTER 17 MONTHS OF UV EXPOSURE.....	2
FIGURE 2. COMPARISON OF THE SPECTRAL REFLECTANCE FOR CHROMIC ANODIZED ALUMINUM AFTER 17 MONTHS OF UV EXPOSURE	3
FIGURE 3. SAMPLE HOLDER REDESIGN	4
FIGURE 4. SPECTRAL RADIOMETER CALIBRATION SET-UP.	5
FIGURE 5. SPECTRAL RADIOMETER SCAN GRAPH	7
FIGURE 6. SPECTRAL REFLECTANCE GRAPH FROM FILE MGF2_OWS.XLS USING OWS	9
FIGURE 7. SPECTRAL REFLECTANCE GRAPHS FOR GOLD-NICKEL PLATED SILICON	11
FIGURE 8. SPECTRAL REFLECTANCE GRAPHS FOR GOLD-CHROME PLATED SILICON	12
FIGURE 9. SPECTRAL REFLECTANCE GRAPHS FOR 6061 ALUMINUM SAMPLES.....	13
FIGURE 10. SPECTRAL REFLECTANCE GRAPHS FOR 2219 ALUMINUM SAMPLES.....	14
FIGURE 11. SPECTRAL REFLECTANCE GRAPHS OF THE OPTICAL WITNESS SAMPLES (OWS) BEFORE AND AFTER AO CLEANING	17
FIGURE 12. SPECTRAL REFLECTANCE GRAPH FOR 2219 ALUMINUM SAMPLE #1, CONTAMINATION TEST	19
FIGURE 13. SPECTRAL REFLECTANCE GRAPH FOR 2219 ALUMINUM SAMPLE #2, CONTAMINATION TEST	20
FIGURE 14. SPECTRAL REFLECTANCE GRAPHS FOR OWS #1, CONTAMINATION TEST	21
FIGURE 15. SPECTRAL REFLECTANCE GRAPH FOR OWS #3, CONTAMINATION TEST.....	22
FIGURE 16. CROSS SECTIONAL VIEW OF THE PROTECTED SAMPLES.....	23
FIGURE 17. TEST SPECIMEN LAYOUT IN THE SAMPLE HOLDER	24
FIGURE 18. SPECTRAL REFLECTANCE GRAPH FOR OWS #1.....	25
FIGURE 19. SPECTRAL REFLECTANCE GRAPH FOR OWS #3.....	26
FIGURE 20. SPECTRAL REFLECTANCE GRAPH FOR OWS #4.....	27
FIGURE 21. SPECTRAL REFLECTANCE GRAPH FOR 2219 ALUMINUM SAMPLE #3.....	28
FIGURE 22. SPECTRAL REFLECTANCE GRAPH FOR 2219 ALUMINUM SAMPLE #4.....	29
FIGURE 23. SPECTRAL REFLECTANCE GRAPH FOR Z-93 SAMPLE #B169-3.....	30
FIGURE 24. SPECTRAL REFLECTANCE GRAPH FOR Z-93 SAMPLE #B169-7.....	31
FIGURE 25. SPECTRAL REFLECTANCE GRAPH FOR Z-93 SAMPLE #B169-13.....	32
FIGURE 26. SPECTRAL REFLECTANCE GRAPH FOR CAA SAMPLE #II-6 TOP.....	33
FIGURE 27. SPECTRAL REFLECTANCE GRAPH FOR CAA SAMPLE #II-6 CENTER.....	34
FIGURE 28. SPECTRAL REFLECTANCE GRAPH FOR CAA SAMPLE #II-6 BOTTOM.....	35
FIGURE 29. SPECTRAL REFLECTANCE GRAPH FOR PYREX WINDOW #1	36
FIGURE 30. SPECTRAL REFLECTANCE GRAPH FOR PYREX WINDOW #2.....	37
FIGURE 31. SPECTRAL REFLECTANCE GRAPH FOR FUSED SILICA WINDOW #1	38
FIGURE 32. SPECTRAL REFLECTANCE GRAPH FOR FUSED SILICA WINDOW #2	39
FIGURE 33. SPECTRAL REFLECTANCE GRAPH FOR OWS #2, CONTROL.....	40
FIGURE 34. SPECTRAL REFLECTANCE GRAPH FOR 2219 ALUMINUM SAMPLE #5, CONTROL.....	41
FIGURE 35. SPECTRAL REFLECTANCE GRAPH FOR Z-93 SAMPLE #B169-1, CONTROL	42
FIGURE 36. SPECTRAL REFLECTANCE GRAPH FOR CAA SAMPLE #II-6 CENTER, CONTROL	43
FIGURE 37. SPECTRAL REFLECTANCE GRAPH FOR FUSED SILICA WINDOW #3, CONTROL	44
FIGURE 38. LPSR DISTANCE STUDY SET-UP.....	45

FIGURE 39. RAY DIAGRAM USING A DIFFUSE SAMPLE 10 MM FROM THE INTEGRATION SPHERE.....	46
FIGURE 40. RAY DIAGRAM USING S SPECULAR SAMPLE 10 MM FROM THE INTEGRATING SPHERE.....	47
FIGURE 41. SOLAR ABSOPTIVITY VERSES STANDOFF FOR VARIOUS SURFACE MATERIALS.....	48
FIGURE 42. SPECTRAL REFLECTANCE VERSES STANDOFF FOR SPECTRALON.....	49
FIGURE 43. SPECTRAL REFLECTANCE VERSES STANDOFF FOR S13G/LO WHITE DIFFUSE PAINT.....	50
FIGURE 44. SPECTRAL REFLECTANCE VERSES STANDOFF FOR A GOLD MIRROR SURFACE	51
FIGURE 45. SPECTRAL REFLECTANCE VERSES STANDOFF FOR AN OPTICAL WITNESS SAMPLE.....	52
FIGURE 46. SPECTRAL REFLECTANCE VERSES STANDOFF FOR 304 STAINLESS STEEL.....	53
FIGURE 47. SPECTRAL REFLECTANCE VERSES STANDOFF FOR BLACK PAINT	54

1.0 INTRODUCTION

The space environment in which the Space Station Freedom and other space platforms will orbit is truly a hostile environment. For example, the current estimates of the integral fluence for electrons above 1 Mev at 2000 nautical miles is above 2×10^{10} electrons/cm²/day and the proton integral fluence is above 1×10^9 protons/cm²/day. At the 200 - 400 nautical miles, which is more representative of the altitude which will provide the environment for the Space Station, each of these fluences will be proportionately less; however, the data indicates that the radiation environment will obviously have an effect on structural materials exposed to the environment for long durations. The effects of this combined environment is the issue which needs to be understood for the long term exposure of structures in space.

In order to better understand the effect of these hostile phenomena on spacecraft, several types of studies are worth performing in order to simulate at some level the effect of the environment. For example the effect of protons and electrons impacting structural materials are easily simulated through experiments using the Van de Graff and Pelletron accelerators currently housed in the Environmental Effects Facility (Building 4605) at MSFC. Proton fluxes with energies of 700 Kev - 2.5 Mev can be generated and used to impinge on sample targets to determine the effects of the particles. Also the Environmental Effects Facility has the capability to generate electron beams with energies from 700 Kev to 2.5 Mev. These facilities will be used in this research to simulate space environmental effects from energetic particles.

Ultraviolet radiation, particularly in the ultraviolet (less than 400 nm wavelength) is less well characterized at this time. The Environmental Effects Facility has a vacuum system dedicated to studying the effects of ultraviolet radiation on specific surface materials. This particular system was assembled in a previous study (NAS8-38609, D.O. 37) in order to perform a variety of experiments on materials proposed for the Space Station. That system has continued to function as planned and has been used in carrying out portions of the proposed study.

2.0 LONG TERM UV RADIATION STUDY

In the beginning of this contract we continued monitoring the chromic anodized aluminum sample that was placed under UV radiation on December 8, 1992. When the sample was analyzed on May 19, 1994, there was concern that the changes in the reflectance were due to contamination rather than UV damage. The solar absorptivity graph and spectral reflectance graph can be found in Figures 1 and 2 on the following pages. As a result, the UV vacuum system was disassembled and thoroughly cleaned. Once the system was verified as contamination free, four types of surfaces were selected for studying the effects of long term ultra-violet radiation in a vacuum system. The system built by The University of Alabama in Huntsville was used to expose Z-93 white diffuse paint, 2219 aluminum, magnesium fluoride optical witness samples and chromic anodized aluminum. Before the long term UV radiation study on these samples could begin, several tasks were necessary. These tasks included, insuring a contamination free UV vacuum test chamber, calibrating the UV source by performing spectral radiometer scans and finally, redesigning the sample holder to accommodate both 1 inch circular disk samples, of varying thickness', and a 2" by 6" by 0.0625 inch plate.

SOLAR ABSORPTIVITY CHANGE IN UV RADIATED CHROMIC ANODIZED ALUMINUM CONTROL VERSUS 17 MONTH UV EXPOSED TEST SAMPLE

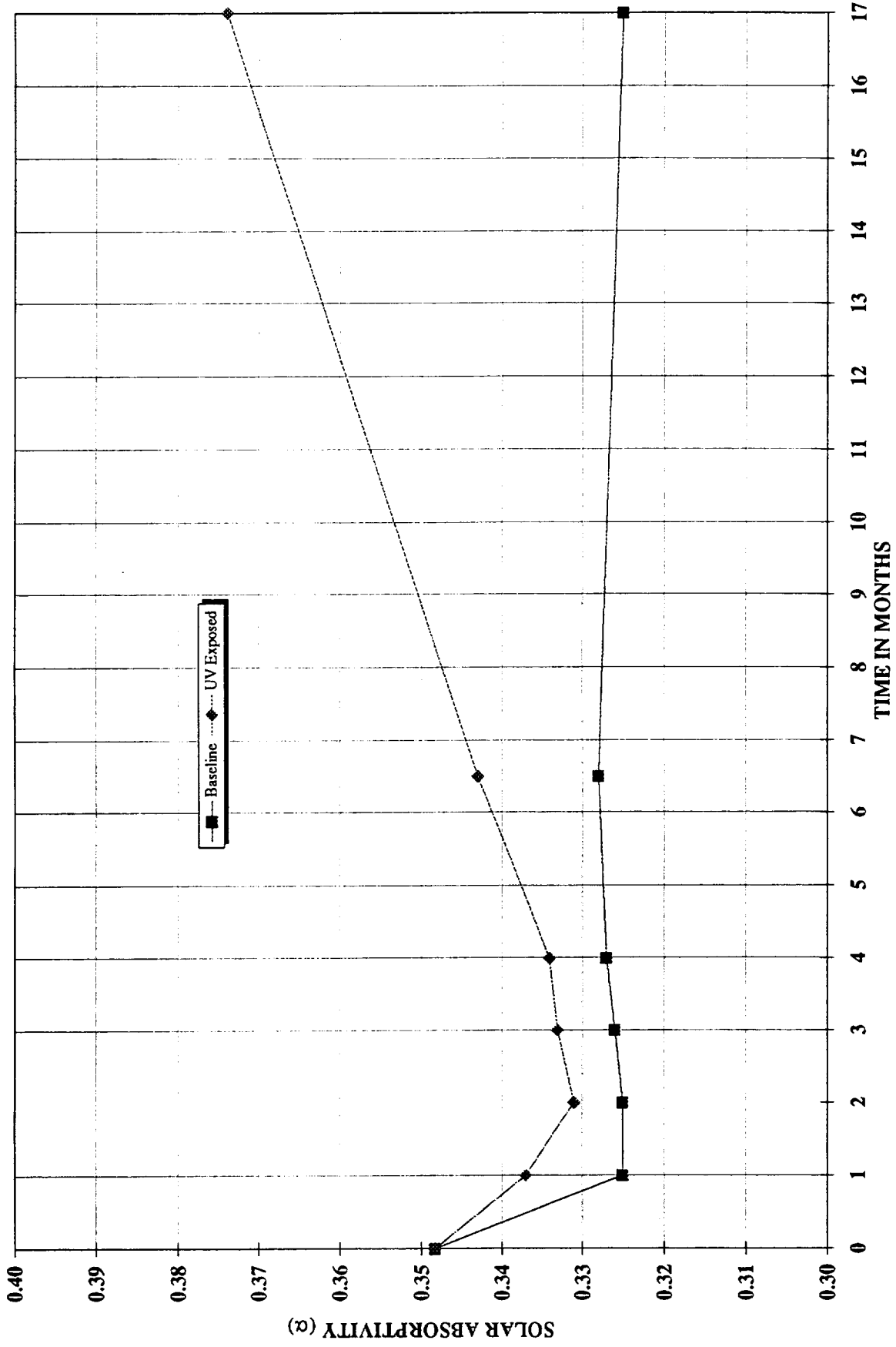

File: TIMEEXP.XLS

Figure 1. CAA Sample Solar Absorptivity During a 17 Month Period.

SPECTRAL REFLECTANCE FOR UV RADIATED CHROMIC ANODIZED ALUMINUM 17 MONTH TOTAL UV EXPOSURE

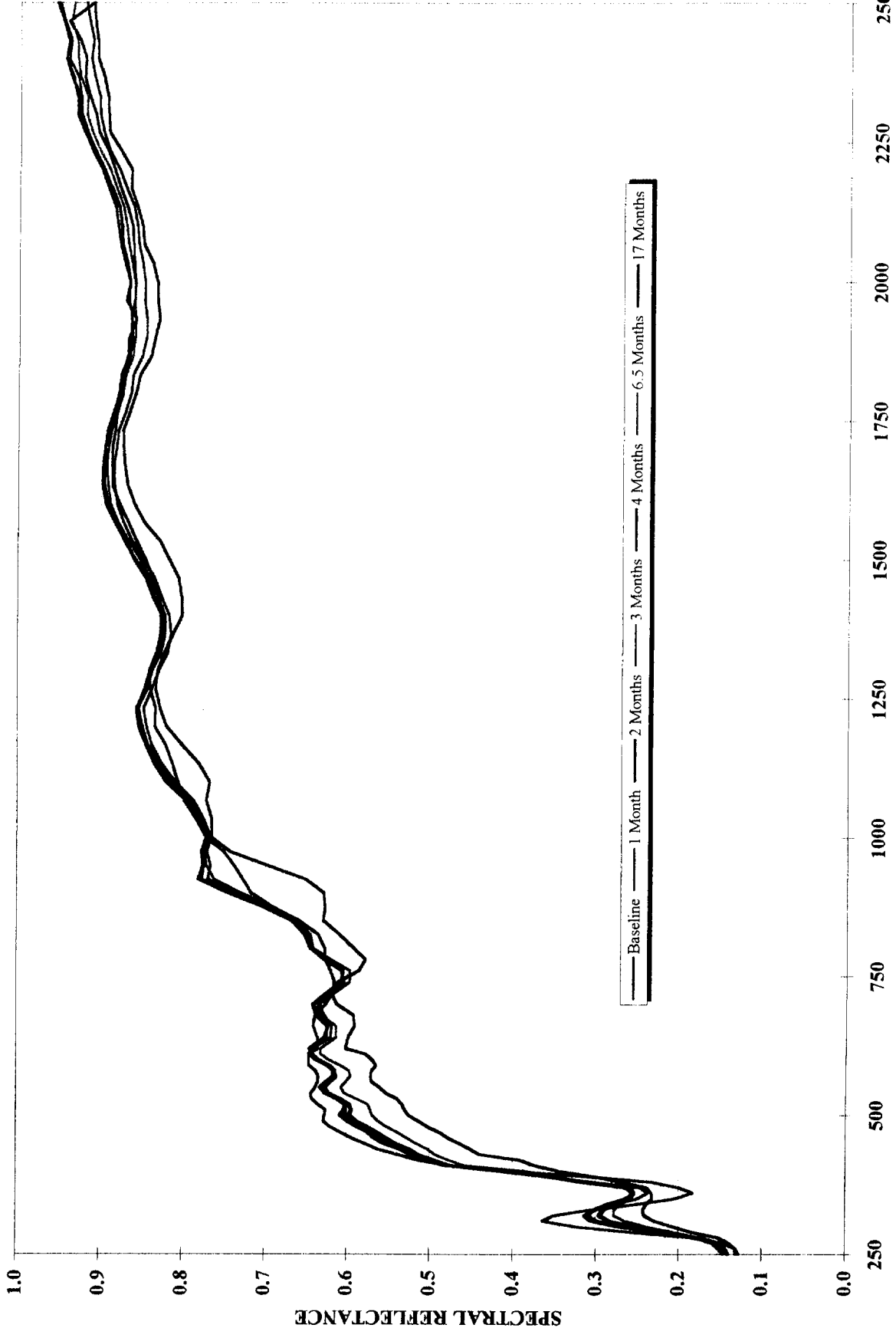
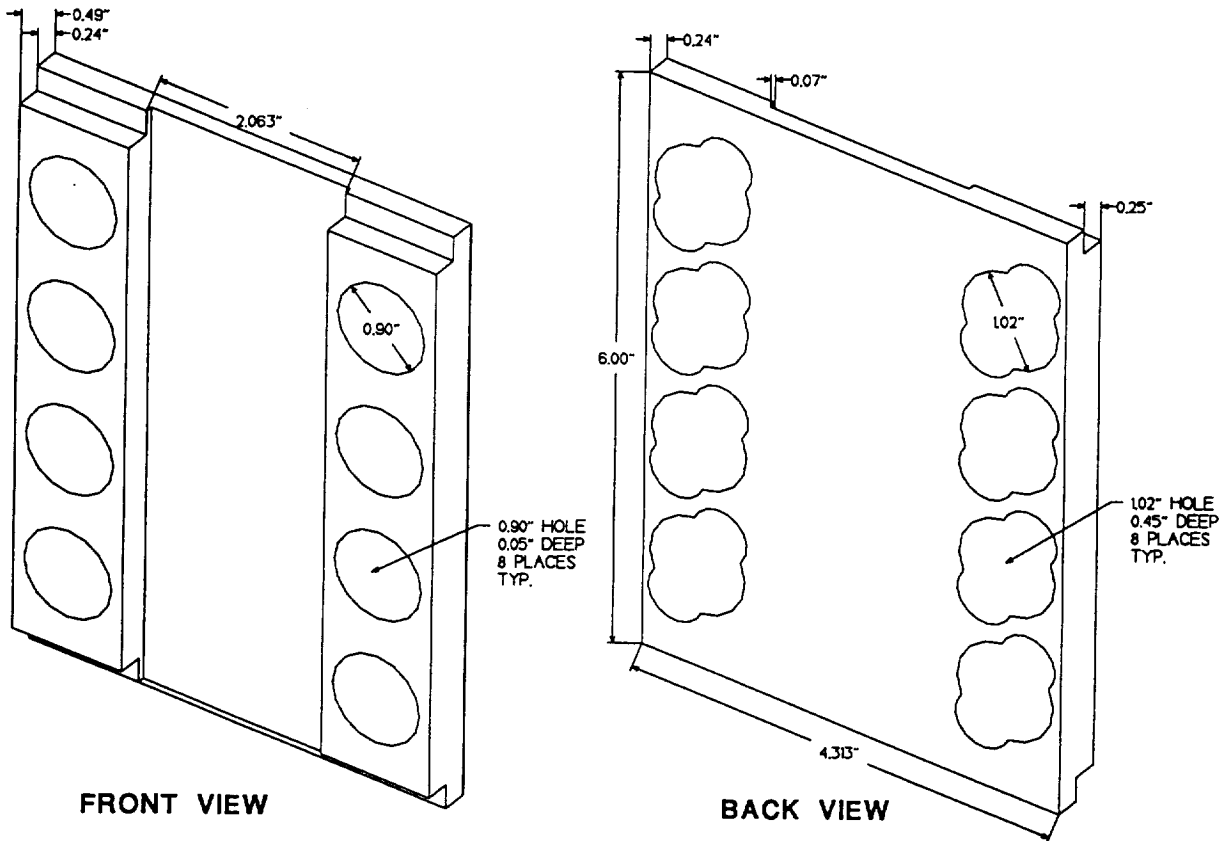

Figure 2. CAA Sample Spectral Reflectance Over a 17 Month Period.

2.1 Sample Holder Re-design

In order to get maximum exposure to the maximum number of samples the sample holder was re-designed to hold eight 1 inch diameter disks of varying thickness and one 2 inch by 6 inch plate. A three dimensional drawing of the final design can be found in Figure 3. The associated dimensioned manufacturing drawings are found in the Appendix.



2.2 Spectral Calibration of the UV Light Source

In previous studies, an optical hand held radiometer was used to verify the amount of sun exposure the samples were receiving. The assumed output on the optical hand held radiometer to attain 1 thermal sun was 6.2 millivolts. It was decided that a more detailed recording of the lamp intensity was desired. Therefore, the mercury-xenon lamp was calibrated using the Optronic Laboratories spectral radiometer model 752 beginning on June 23, 1994. A spectral scan is now performed from 200 to 400 nanometers with one nanometer increments. It is assumed throughout the calibration with the Optronic Laboratories spectral radiometer that 11.6 milliwatts per square centimeter equals one UV sun. Various scans were performed in order to characterize the system. Scans were performed with and without the UV viewport. Testing was also conducted to measure the thermal drift of the spectral radiometer and UV lamp itself. A total of twenty-seven runs were performed with these various conditions. A spreadsheet with the various parameters and outputs can be found on the following page. Below is a diagram showing the typical setup in measuring the amount of UV expose the samples are receiving. This set-up described below is used whenever the bulb is replaced or any calibration tests are performed.

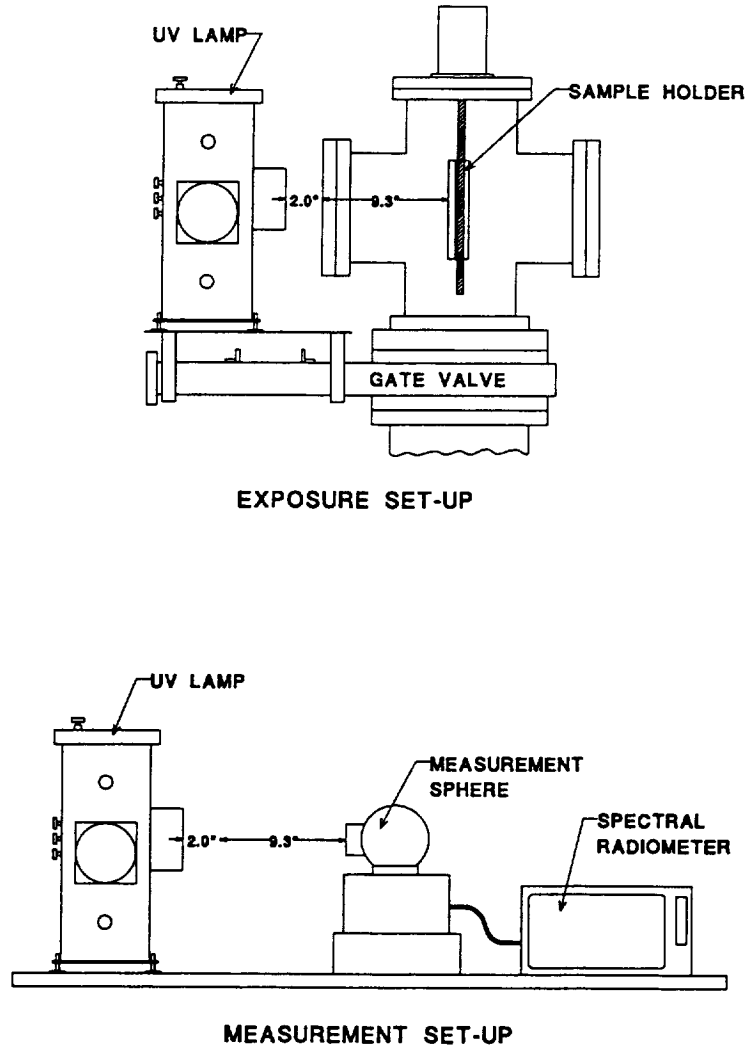

Figure 4. Spectral Radiometer Calibration Set-up.

2.2.1 Results

It was found that when the hand held radiometer read 6.3 millivolts the P.M. tube on the Optronic Laboratories spectral radiometer overloaded. The current was reduced on the mercury-xenon lamp until the output was set between 2.5 to 3 UV suns. The final settings on the UV lamp power supply were 18 volts at 23.5 amps. These settings are only a guideline due to the characteristics of the bulb changing over time. To achieve an accurate reading of the intensity of the lamp a full spectral scan must be performed on the lamp. The spectral graphs of the original lamp which had over 12,700 hours of operation can be found on the following pages.

SUMMARY OF SPECTRAL RADIOMETER SCANS ON VARIAN NEAR UV SYSTEM

NOTES:

1. INSTRUMENT USED WAS OPTRONIC LABORATORIES MODEL 752
2. ALL SCANS USED CALIBRATION FILE D9431NM.CAL
3. OHH = OPTICAL HAND HELD RADIOMETER, BLACK BODY THERMOPILE, ASSUMED OUTPUT OF 6.2 TO 6.3 mVDC = 1 THERMAL SUN
4. UV SUN EQUIVALENTS BASED ON 11.6 mW/sq cm = 1 UV SUN
5. ALL SCANS FROM 200 TO 400 nm AT 1 nm INCREMENTS
6. STARTING AFTER RUN T7 ALUMINUM FOIL WAS PLACED IN FRONT OF SPHERE AFTER A SCAN TO CUT DOWN ON THERMAL DRIFTING.

FILE NAME	DATE	OHH	IRRADIANCE	UV SUNS	COMMENTS
MCPH26.DAT	3/28/94	4.3 mV	45.8 mW/sq cm	3.95	24" SOURCE TO TARGET DISTANCE, NEW LAMP USED IN MCPHERSON SYSTEM
T1.DAT	6/23/94	4.8 mV	57.10 mW/sq cm	4.92	CONDITION OF HgXe LAMP AFTER 17 MONTH RUN TIME, UV WINDOW IN BEAM PATH, 11.3" SEPARATION
T2.DAT	6/23/94	4.3 mV	47.32 mW/sq cm	4.08	RUN CONDITIONS SAME AS T1.DAT EXCEPT FLUX ADJUSTED TO 4.3 mV
T3.DAT	6/23/94	4.3 mV	52.15 mW/sq cm	4.49	RUN CONDITIONS SAME AS T2.DAT EXCEPT 24" SOURCE TO TARGET DISTANCE
T4.DAT	6/23/94	4.7 mV	58.37 mW/sq cm	5.03	RUN CONDITIONS SAME AS T3.DAT EXCEPT UV WINDOW REMOVED.
T5.DAT	6/30/94	3.0 mV	35.94 mW/sq cm	3.09	RUN CONDITIONS SAME AS T1.DAT EXCEPT DEFOCUSSED ABOUT 50% FROM ORIGINAL SETTING.
T6.DAT	6/30/94	2.7 mV	45.27 mW/sq cm	3.91	RUN CONDITIONS SAME AS T5.DAT EXCEPT DEFOCUSSED ABOUT 25% MORE. WHY DID IRRADIANCE GO UP?
T7.DAT	6/30/94	2.5 mV	56.85 mW/sq cm	4.91	RUN CONDITIONS SAME AS T5.DAT EXCEPT DEFOCUSSED AS MUCH AS POSSIBLE. IRRADIANCE STILL HIGHER???
T8.DAT	6/30/94	2.5 mV	54.59 mW/sq cm	4.70	RUN CONDITIONS SAME AS T7.DAT EXCEPT 45 MIN. LATER. PLACED FOIL IN FRONT OF SPHERE AFTER RUN T7.DAT.
T9.DAT	6/30/94	2.0 mV	44.62 mW/sq cm	3.84	RUN CONDITIONS SAME AS T8.DAT EXCEPT MOVED LAMP BACK 2 INCHES.
T10.DAT	6/30/94	1.5 mV	28.39 mW/sq cm	2.45	RUN CONDITIONS SAME AS T7.DAT EXCEPT DROPPED CURRENT TO 21.0 AMPS ON LAMP POWER SUPPLY.
T11.DAT	6/30/94	1.6 mV	25.46 mW/sq cm	2.20	RUN CONDITIONS SAME AS T7.DAT EXCEPT INCREASED CURRENT TO 22.0 AMPS.
T12.DAT	6/30/94	1.8 mV	30.01 mW/sq cm	2.59	RUN CONDITIONS SAME AS T7.DAT EXCEPT INCREASED CURRENT TO 23.0 AMPS.
T13.DAT	6/30/04	2.0 mV	37.27 mW/sq cm	3.22	RUN CONDITIONS SAME AS T7.DAT EXCEPT INCREASED CURRENT TO 23.5 AMPS.
T14.DAT	6/30/94	1.9 mV	34.33 mW/sq cm	2.96	RUN CONDITIONS SAME AS T7.DAT EXCEPT DECREASED CURRENT TO 23.0 AMPS
T15.DAT	6/30/94	1.9 mV	31.64 mW/sq cm	2.72	RUN CONDITIONS SAME AS T14.DAT EXCEPT 1 HOUR LATER
T16.DAT	7/1/94	1.8 mV	24.96 mW/sq cm	2.15	RUN CONDITIONS SAME AS T14.DAT EXCEPT 17 HOURS LATER.
T17.DAT	7/1/94	2.1 mV	36.78 mW/sq cm	3.17	RUN CONDITIONS SAME AS T16.DAT EXCEPT INCREASED CURRENT TO 24.0 AMPS.
T18.DAT	7/1/94	2.2 mV	40.69 mW/sq cm	3.51	RUN CONDITIONS SAME AS T16.DAT EXCEPT 45 MINUTES LATER.
T19.DAT	7/1/94	2.1 mV	37.87 mW/sq cm	3.26	RUN CONDITIONS SAME AS T16.DAT EXCEPT DECREASED CURRENT TO 23.5 AMPS.
T20.DAT	7/1/94	2.0 mV	35.03 mW/sq cm	3.02	RUN CONDITIONS SAME AS T19.DAT EXCEPT 50 MINUTES LATER
T21.DAT	7/1/94	2.2 mV	39.10 mW/sq cm	3.37	RUN CONDITIONS SAME AS T20.DAT EXCEPT UV WINDOW REMOVED FROM BEAM.
T22.DAT	7/5/94	2.2 mV	41.54 mW/sq cm	3.58	RUN CONDITIONS SAME AS T21.DAT EXCEPT 90 HOURS LATER.
T23AVE1.DAT	7/5/94	2.2 mV	35.37 mW/sq cm	3.05	CONDITIONS SAME AS T22 EXCEPT ALLOWED SPHERE TO WARM UP FOR 70 MINUTES, 1ST OF 5 RUNS FOR AVE.
T23AVE2.DAT	7/5/94	2.2 mV	35.53 mW/sq cm	3.06	CONDITIONS SAME AS T23AVE1.DAT EXCEPT 5 MINUTES LATER, 2ND OF 5 RUNS FOR AVE.
T23AVE3.DAT	7/5/94	2.2 mV	35.43 mW/sq cm	3.05	CONDITIONS SAME AS T23AVE2.DAT EXCEPT 5 MINUTES LATER, 3RD OF 5 RUNS FOR AVE.
T23AVE4.DAT	7/5/94	2.2 mV	36.59 mW/sq cm	3.15	CONDITIONS SAME AS T23AVE3.DAT EXCEPT 5 MINUTES LATER, 4TH OF 5 RUNS FOR AVE.
T23AVE5.DAT	7/5/94	2.2 mV	34.04 mW/sq cm	2.94	CONDITIONS SAME AS T23AVE4.DAT EXCEPT 5 MINUTES LATER, 5TH OF 5 RUNS FOR AVE.
					FOR ALL T23AVE#.DAT RUNS THERE WAS NO UV WINDOW WAS IN THE BEAM PATH.

SPECTRAL OUTPUT COMPARISON BETWEEN THE OLD AND NEW HgXe LAMP

OLD LAMP HAS 12,700 HOURS OF OPERATION, LOGARITHMIC Y SCALE

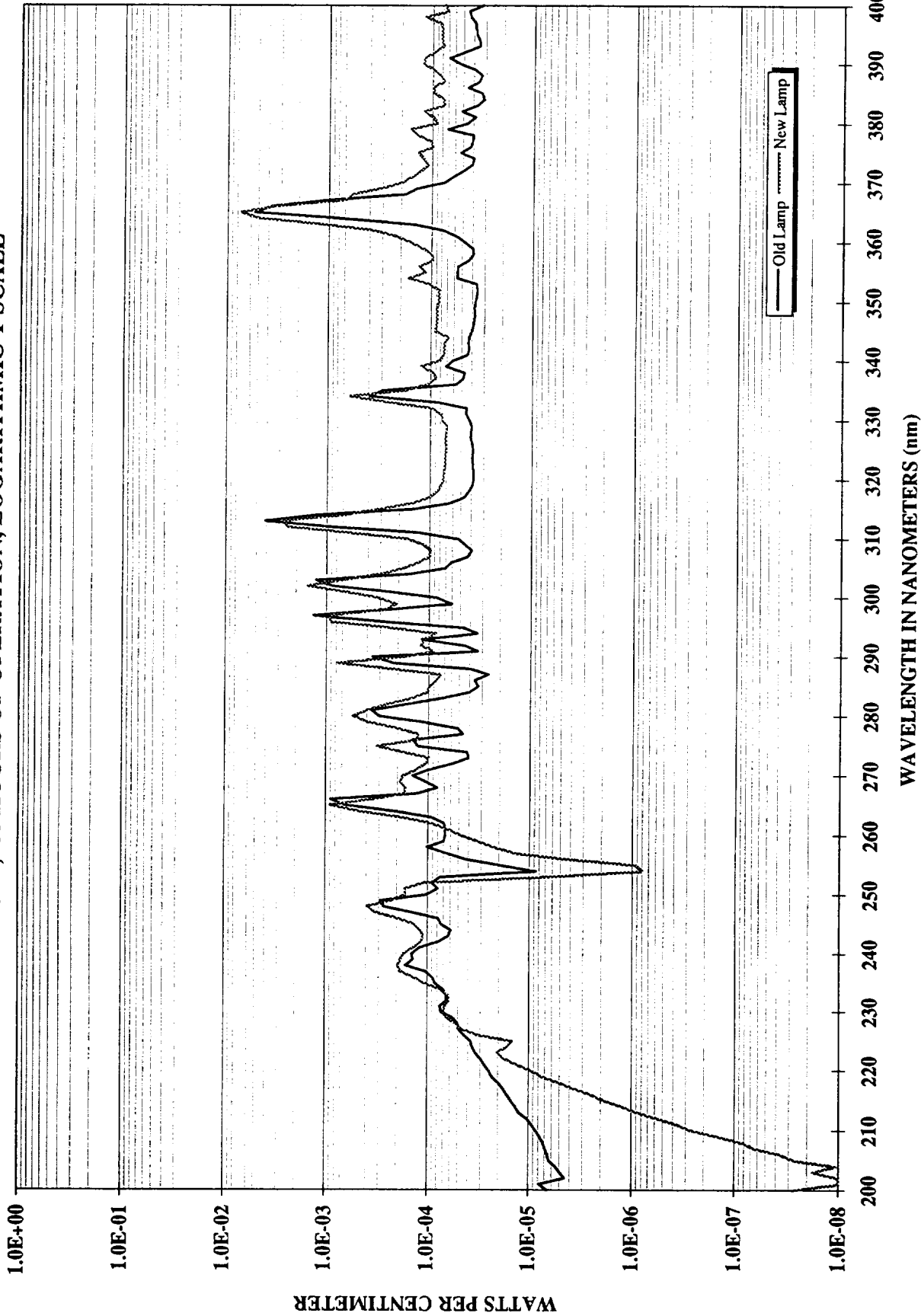

Figure 5. Spectral Output Comparison between Old and New HgXe Lamps.

2.3 Contamination Free Verification

To clean the UV vacuum system a procedure was developed. The procedure included cleaning the components first with Alconox using a Scotch Brite pad, flushing with water, then 50%-50% MEK and 200 proof ethyl alcohol, then pure 200 proof ethyl alcohol and finally blow drying with dry nitrogen; never letting the part dry in between procedures.

2.3.1 Solvent Cleaning of the Vacuum System

On May 23, 1994, cleaning began on the UV vacuum system. The flanges and glass viewports were cleaned by first scrubbing them with an Alconox and cool water solution. Then rinsed thoroughly in cool tap water. The hot water was not used due to residue in the water and a non-constant flow. Once the parts were flushed with cool water, the small parts that fit into a 1000 ml beaker were ultrasonically cleaned for 20 minutes or more in a MEK/ethyl alcohol bath and then placed in a ethyl alcohol bath for another 20 minutes. Once removed from the ethyl alcohol, the parts were blown dry with dichlorodifluoromethane and wrapped in aluminum foil bought from the NASA supply store. Parts that were too large for the ultrasonic cleaner were taken outside and flushed with an MEK/ethyl alcohol mixture, then pure ethyl alcohol and blown dry with dichlorodifluoromethane and wrapped in aluminum foil. The parts were never allowed to dry in between any of the stages of the cleaning procedure. The rotary feed through, bleed valve and parts that could not be flushed with MEK and ethyl alcohol due to damage to the component were wiped down with MEK then ethyl alcohol using alpha wipes. After all parts were cleaned they were inspected using a black light to see if the parts fluoresced. Upon inspection with the black light, it was found that several areas in the 4-way cross sample chamber fluoresced brightly and appeared that the contaminant had been smeared rather than removed. Attempts to remove the substance by rubbing the areas with MEK on an alpha wipe were unsuccessful. It was decided to have Engineering Maintenance Services grit blast and degrease the 4 way cross sample chamber to remove any possible contamination. Upon inspection of the sample chamber after cleaning, duct tape residue was found on almost every flange and one area around the top flange. The tape residue was removed using an alpha wipe soaked in an MEK and ethanol mixture.

Once the tape residue was removed, the system was reassembled and pumped down using the Contamination Free Roughing Pump (CFR). The system would not switch to the ion pumps. Whenever the ion pumps were turned on a blue plasma appeared. The system was thus left on the CFR and we began heating the outside of the sample chamber with a Master heat gun for approximately two hours. After numerous hours of pumping and two hours of heating the ion pumps refused to start. The ion pumps were finally started with the 13" gate valve closed by alternatively powering up the two ion power supplies. After two days of pumping with the ion pumps, the 13" gate valve was opened and the vacuum rose to 10^{-5} level before quickly dropping to 10^{-8} level. A heater tape was wrapped on the sample chamber and the chamber was heated to about 50° C for four days. The UV light source was calibrated to 3 UV suns and tested for drift. The details of the calibration procedures and results can be found below in Section 2.3. On July 1, 1994 an optical witness sample (MgF₂ mirror) was mounted in the sample holder placed in the UV vacuum chamber and UV radiated at 3 UV suns for 171 hours. The LPSR scans revealed contamination in the system. The graphical data can be found in Figure 6 on the following page.

OPTICAL WITNESS SAMPLE TEST IN THE VARIAN UV SYSTEM- LPSR DATA

BASELINE VS. 171 HRS OF 3 UV SUN EXPOSURE, ALPHA=0.094 BEFORE VS. 0.093 AFTER EXPOSURE

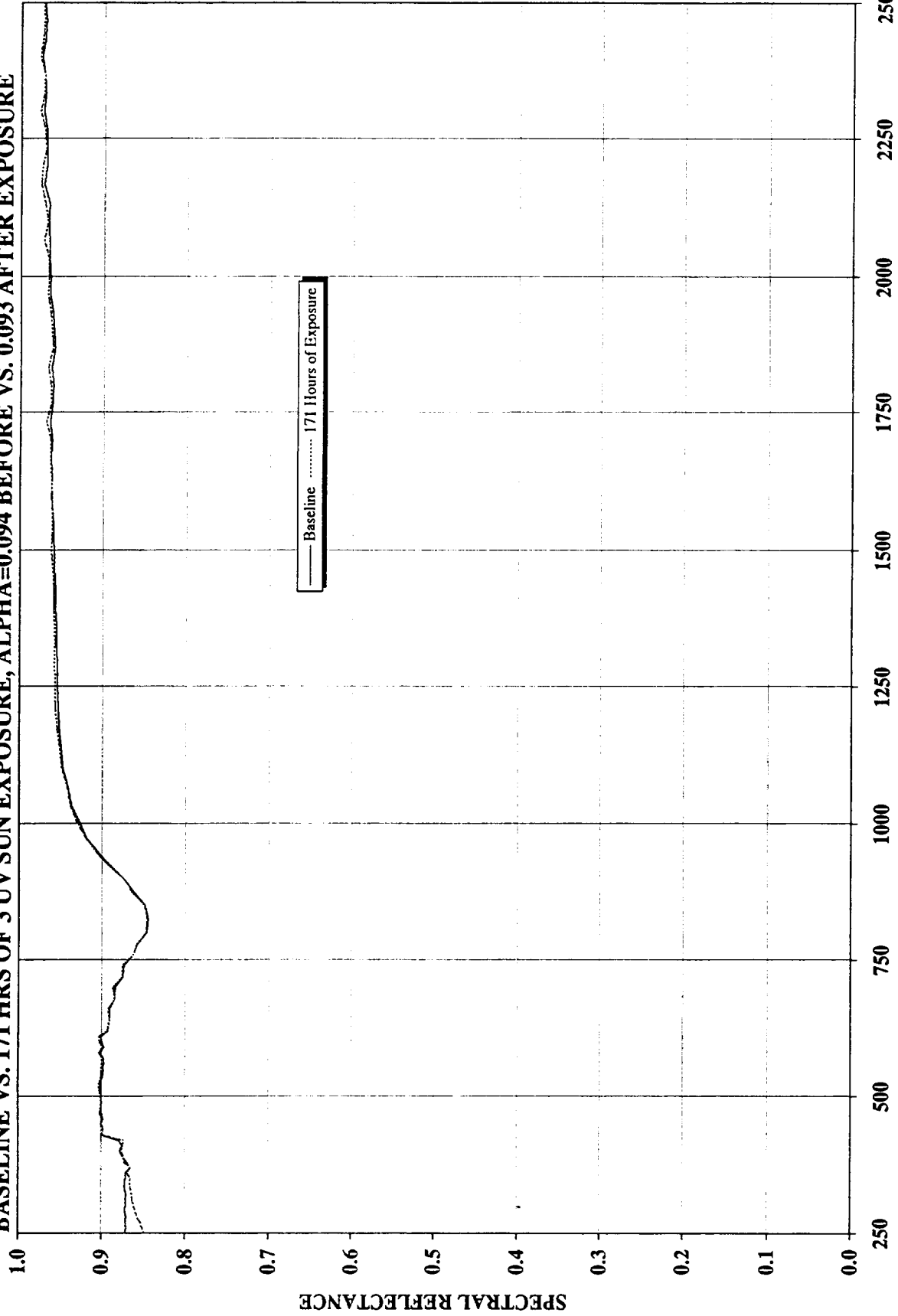

WAVELENGTH IN NANOMETERS (nm)

Figure 6. Optical Witness Sample Before and After UV Exposure.

Data taken on 7/1/94 7/13/94
File: MGF2_OWS.XLS

The solar alpha of 0.094 before and 0.093 after radiation showed no obvious change. But when analyzing the spectral reflectance a definite change can be seen from 375 nanometers to 250 nanometers which is typical in contaminated systems. The next step to cleaning the system was performing a glow discharge.

2.3.2 Glow Discharge Cleaning of the Vacuum System

A Sorensen high voltage power supply, high purity aluminum wire, a high voltage feedthrough and 99.996% high purity oxygen were used to construct the glow discharge. The high purity aluminum served as the electrode of the system. High purity oxygen (99.996% min.) was slowly bled into the system using a needle valve to generate the atomic oxygen. When the Sorensen high voltage supply was turned on, the blue glow from the atomic oxygen was located inside the 4" port but did not extend into the sample chamber. The power supply was not large enough to allow the atomic oxygen to enter the sample chamber. It was thus determined that this method for generating atomic oxygen was not sufficient and that we needed to use the ion pumps to generate the plasma field. The high purity aluminum wire was removed and the 4" blank was replaced. The ion pumps were alternately turned on for 5 to 10 minute intervals to prevent overheating of the ion power supplies. The CFR pump was run continuously with its isolation valve slightly opened. The high purity oxygen was slowly bled into the system until the vacuum plasma began to diminish. When the oxygen was bled into the system the plasma would change from a grayish white to green in color. It was noticed that the plasma was approximately 1/2" to 1 inch from the walls of the chamber. Magnets were then used to direct the plasma towards the walls. This was continued until the walls became warm to the touch. After two hours of plasma, the chamber was pumped down and the ion pumps turned on. Seven days later, two gold-nickel plated silicon samples, two gold-chrome plated silicon sample, two 6061 and 2 2219 aluminum samples were run on the LPSR. After scanning the eight samples, four test samples were placed in the UV vacuum chamber to test the system for contamination. The samples were exposed to 3 UV suns for 98 hours. The samples were removed and LPSR scans performed. The spectral reflectance graphs can be found in Figures 7-10 on the following pages.

GOLD-NICKLE SILICON WAFER CONTAMINATION TEST IN THE UV SYSTEM BASELINE VS. 98 HRS OF 3 UV SUN EXPOSURE, ALPHA=0.207 BEFORE VS. 0.206 AFTER EXPOSURE, LPSR DATA

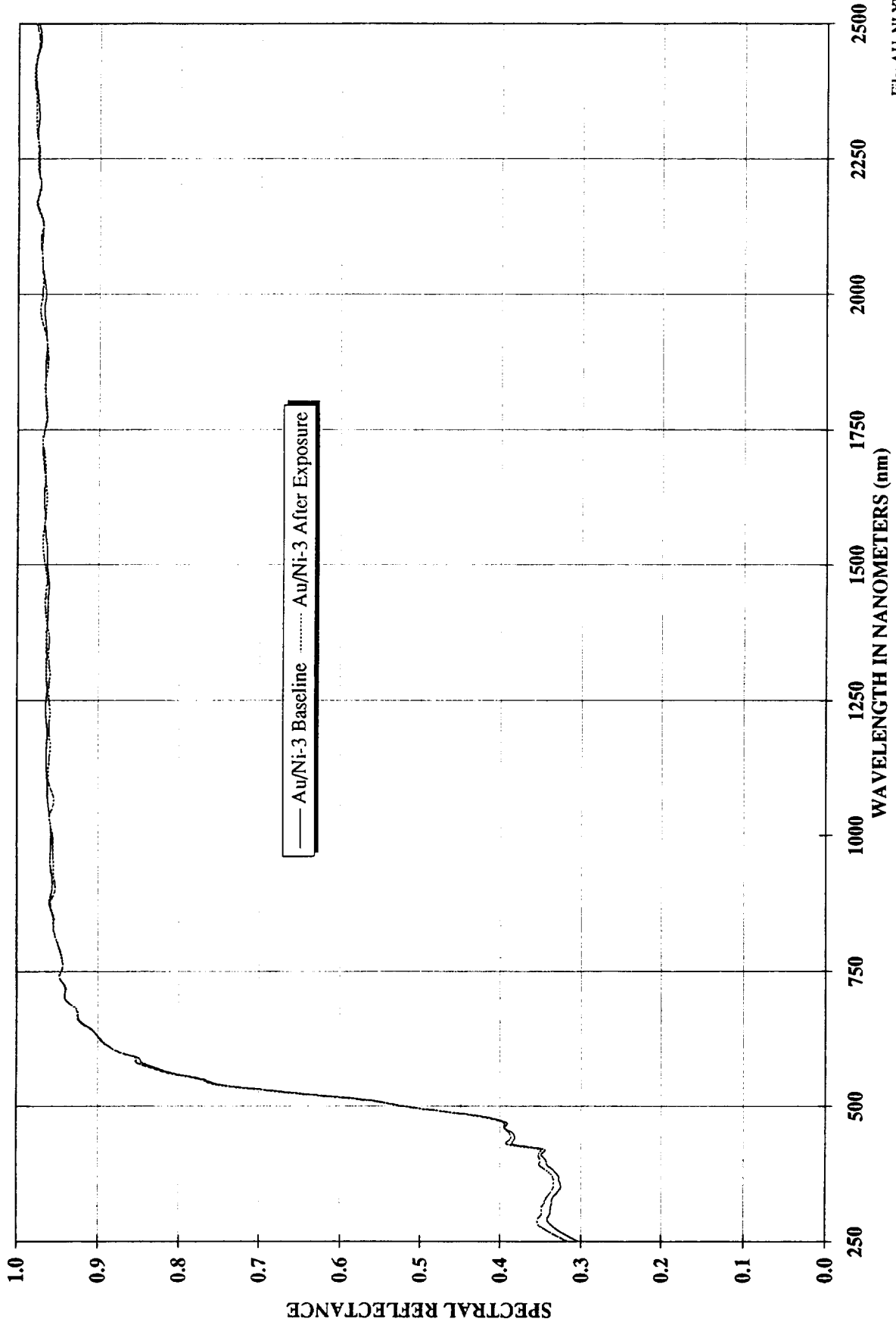
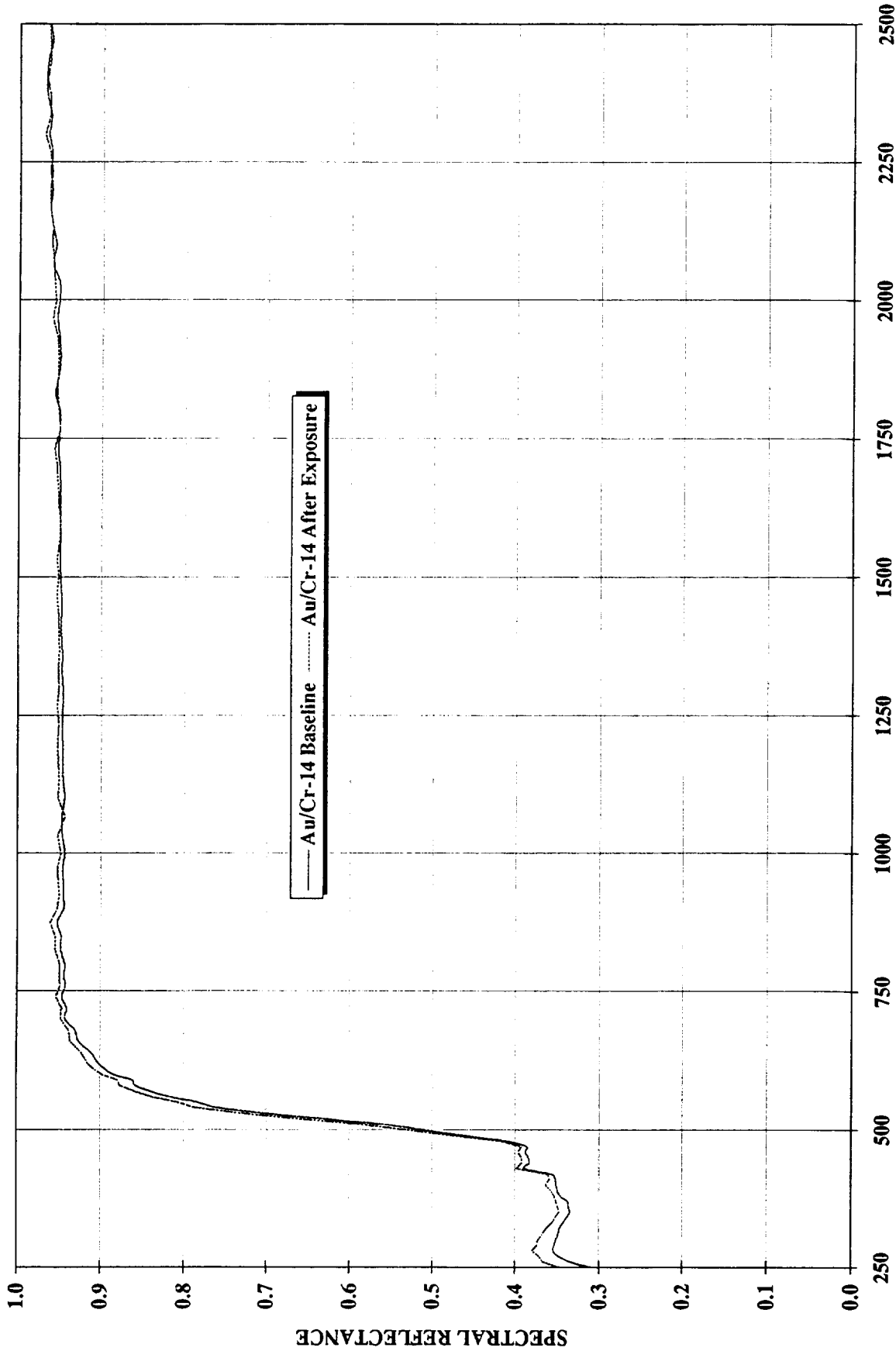

Figure 7. Gold-Nickle Silicon Wafer Sample Before and After UV Exposure

File: AU_NI.XLS
Data taken on 7/27/94 8/01/94

**GOLD-CHROME SILICON WAFER CONTAMINATION TEST IN THE UV SYSTEM
 BASELINE VS. 98 HRS OF 3 UV SUN EXPOSURE, ALPHA = 0.212 BEFORE VS. 0.204 AFTER EXPOSURE, LPSR DATA**



WAVELENGTH IN NANOMETERS (nm)
 Figure 8. Gold-Chrome Silicon Wafer Sample Before and After UV Exposure.

**6061 ALUMINUM SAMPLE TEST IN THE VARIAN UV SYSTEM-LPSR DATA
BASELINE VS. 98 HRS OF 3 UV SUN EXPOSURE, ALPHA = 0.221 BEFORE VS. 0.217 AFTER EXPOSURE**

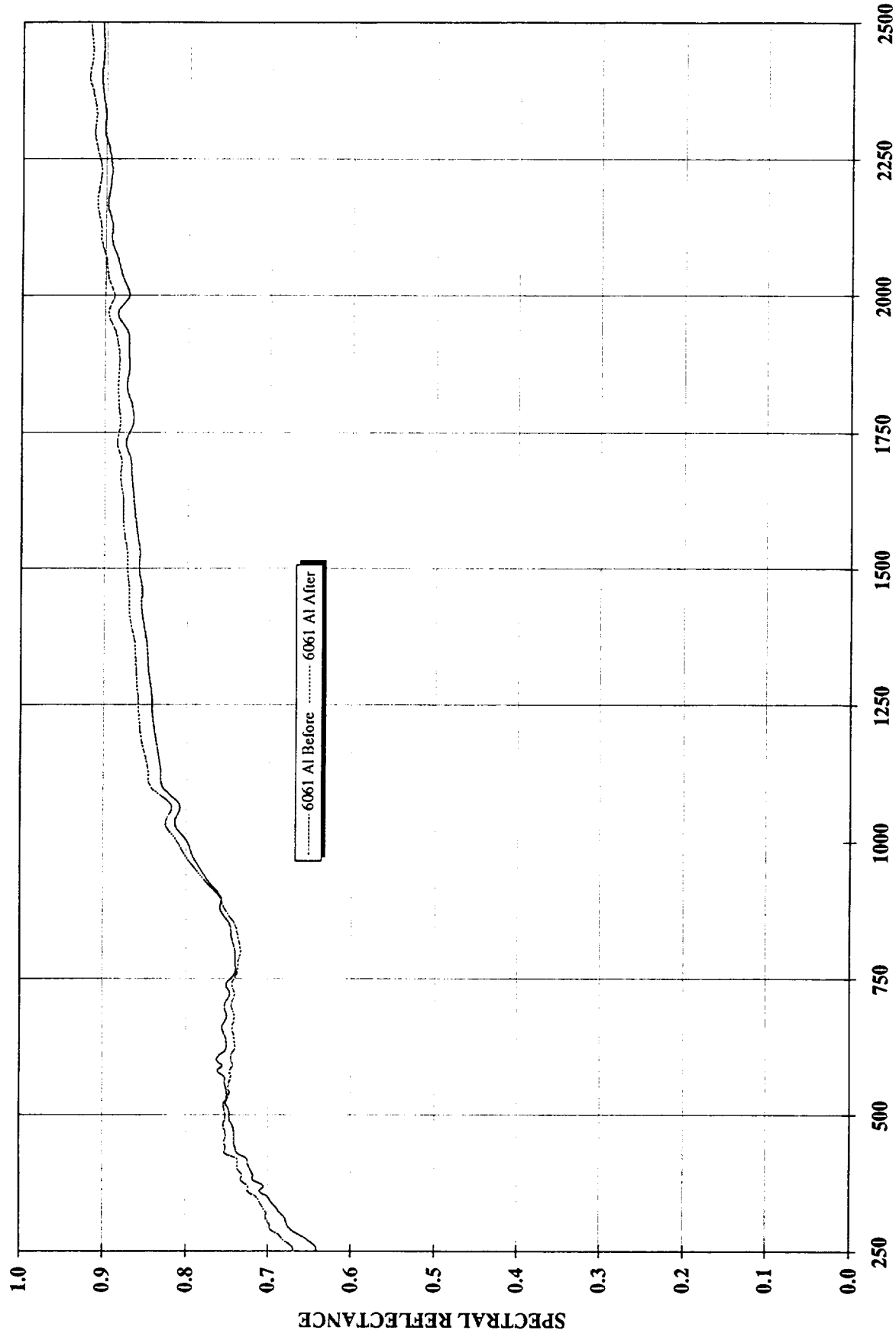

Figure 9. 6061 Aluminum Sample Before and After UV Exposure.

**2219 ALUMINUM CONTAMINATION TEST IN THE VARIAN UV SYSTEM-LPSR DATA
BASELINE VS. 98 HRS OF 3 UV SUN EXPOSURE, ALPHA = 0.236 BEFORE VS. 0.233 AFTER EXPOSURE**

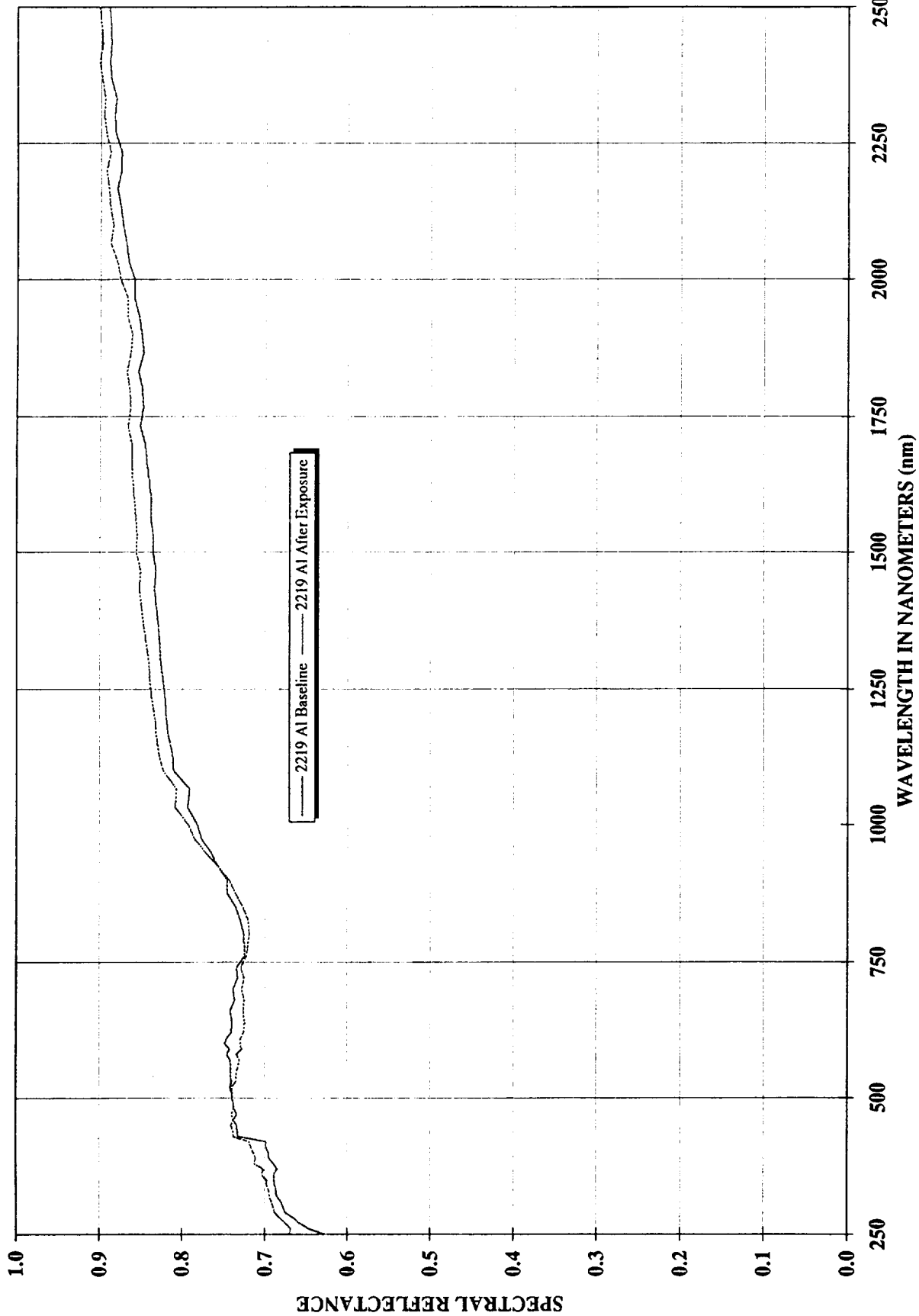

Figure 10. 2219 Aluminum Sample Before and After UV Exposure.

As seen from the graphs, the reflectance decreased in the visible range on both the 2219 and 6061 aluminum samples. But there was an increase in the spectral reflectance for the gold- nickel plated silicon and gold-chrome plated silicon samples. Due to concerns with the results, it was decided to continue cleaning the UV vacuum system with atomic oxygen.

The sample holder assembly was thus removed and the cathode was replaced. This time high purity copper was used for the cathode. The Sorensen voltage supply was used instead of the ion power supplies because the plasma was going to be created continuously thus causing concern with overheating the ion power supplies. The system was set-up equivalent to the previous run except that copper was used instead of aluminum for the cathode. Once the high voltage feedthrough and cathode had been placed into the vacuum system, it was cleaned with the atomic oxygen for over 35 hours. It was noticed after the AO cleaning that a layer of copper had been deposited over the entire inner surface of the chamber including the two viewports. The viewports were removed and polished clean to remove the copper film deposited during the AO cleaning. Once this was completed, we began preparation to check for contamination in the system.

Four optical witness and four 2219 aluminum samples were used to check for contamination of the system. The newly designed sample holder was used to hold the four test samples. The samples, sample holder and mounting hardware for the sample holder were to be cleaned in the Boeing atomic oxygen system located in building 4711 to insure that they were also contamination free.

Thorough cleaning was performed on the 2219 aluminum samples and the newly designed sample holder before they were placed in the Boeing AO system. Cleaning of the sample holder included the following steps, glass bead blasting by ABRO Machining, scrubbing with Alconox followed by a de-ionized water rinse, acetone flush, DI rinse, 60 second dip in 10% ACS grade NaOH and DI water, followed by a DI water rinse and finally flushed with 200 proof ethanol. The sample holder was then placed on aluminum foil in a drying oven. The sample holder, spacer rings and spring clips were then taken to building 4711 at NASA to be placed in the Boeing AO system. They were cleaned in the AO system for two hours and 12 minutes. When the parts were removed, it was discovered that brown stripes were randomly located on the sample holder. Due to concern about the origin of the brown stripes, it was determined to re-clean the holder. The holder was chemically re-cleaned using the same method described earlier to try and remove the brown stains. This was not totally successful and it was determined to grit blast the holder using Thiokol's Zirclean system in building 4711 at MSFC. After grit blasting with Thiokol's system, the sample holder was chemically cleaned by the same method mentioned above. The sample holder was not re-cleaned in Boeing's AO system.

The 2219 aluminum samples and optical witness samples were cleaned in a slightly different fashion due to there size and material characteristics. The following steps were used to clean the 1 inch 2219 aluminum discs, first they were ultrasonically cleaned in acetone followed by a DI water rinse, sanded to a random scratch pattern of 600 grit using silicon carbide paper and DI water, ultrasonically cleaned for ten minutes in acetone followed by a DI water rinse, placed in 10% NaOH and DI water mixture, followed by DI water rinse and an acetone rinse and finally blown dry with dry Nitrogen. Once the samples were all cleaned, the optical witness samples and 2219 aluminum samples were then placed in the Boeing AO system for 3 hours. LPSR scans were performed on the samples before and after AO cleaning but no difference was found in the

spectral reflectance. The spectral reflectance graphs for the OWS before and after AO cleaning can be found in Figure 11 on the following page. The 2219 aluminum samples #1 and #2 and optical witness samples #1 and #3 were installed into the new sample holder and exposed to 3 UV suns for 14 days.

OPTICAL WITNESS SAMPLE BEFORE AND AFTER ATOMIC OXYGEN CLEANING

LPSR DATA

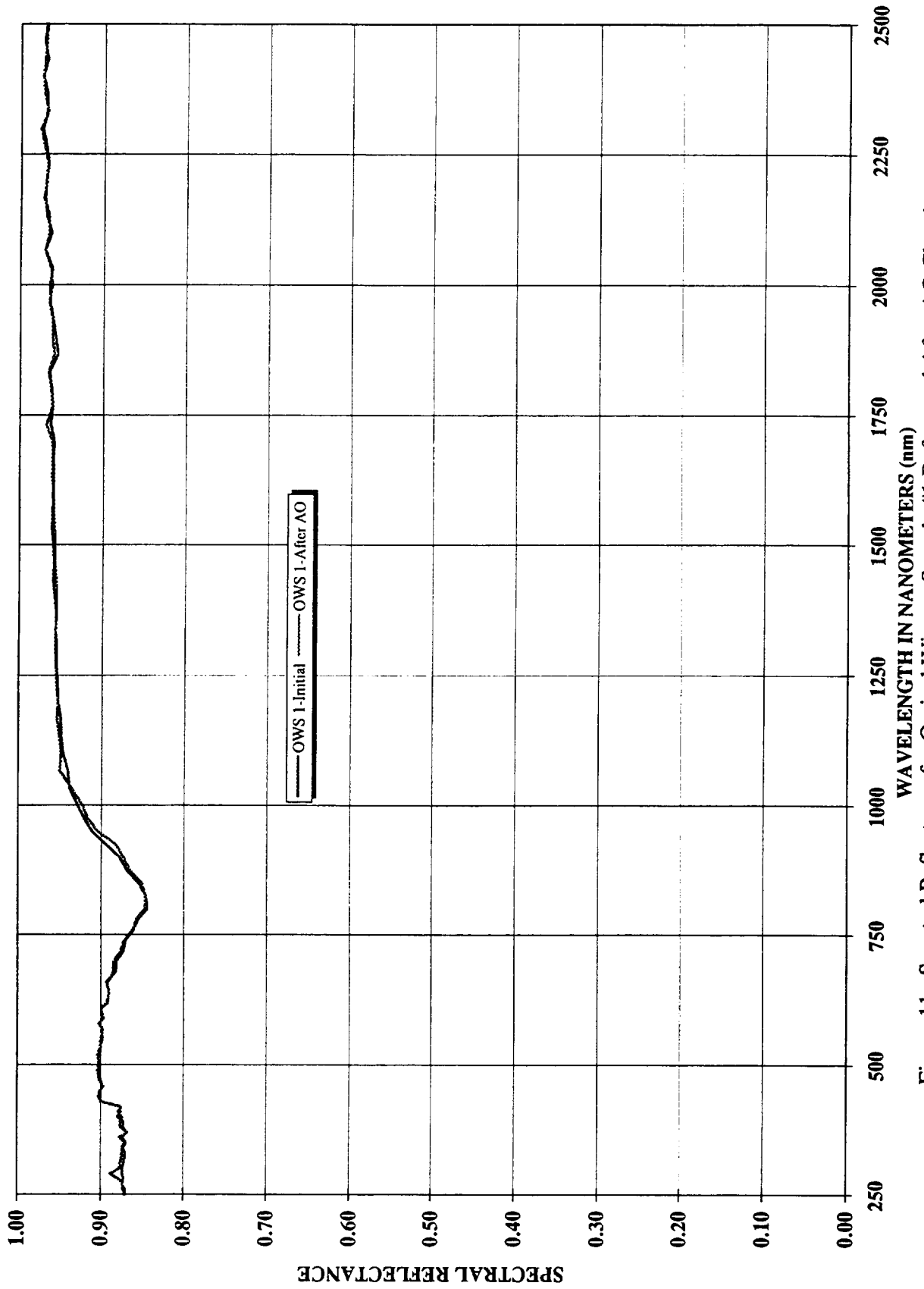

Figure 11. Spectral Reflectance for Optical Witness Sample #1 Before and After AO Cleaning.

2.3.3 Results

After 14 days of radiation the samples were removed from UV vacuum system. The test and control samples were run on the LPSR to attain the spectral reflectance and solar alpha. There was no change in the spectral reflectance from the range of 250 nanometers to 2500 nanometers. The spectral reflectance graphs can be found in Figures 12-15 on the following pages. A contamination free system was verified, thus preparation began on the samples for the long term UV exposure study.

**2219 ALUMINUM SAMPLE #1 CONTAMINATION STUDY FOR THE UV VACUUM SYSTEM
BASELINE VS. 14 DAYS OF 3 UV SUN EXPOSURE, ALPHA=0.33 BEFORE VS 0.323 AFTER EXPOSURE, LPSR DATA**

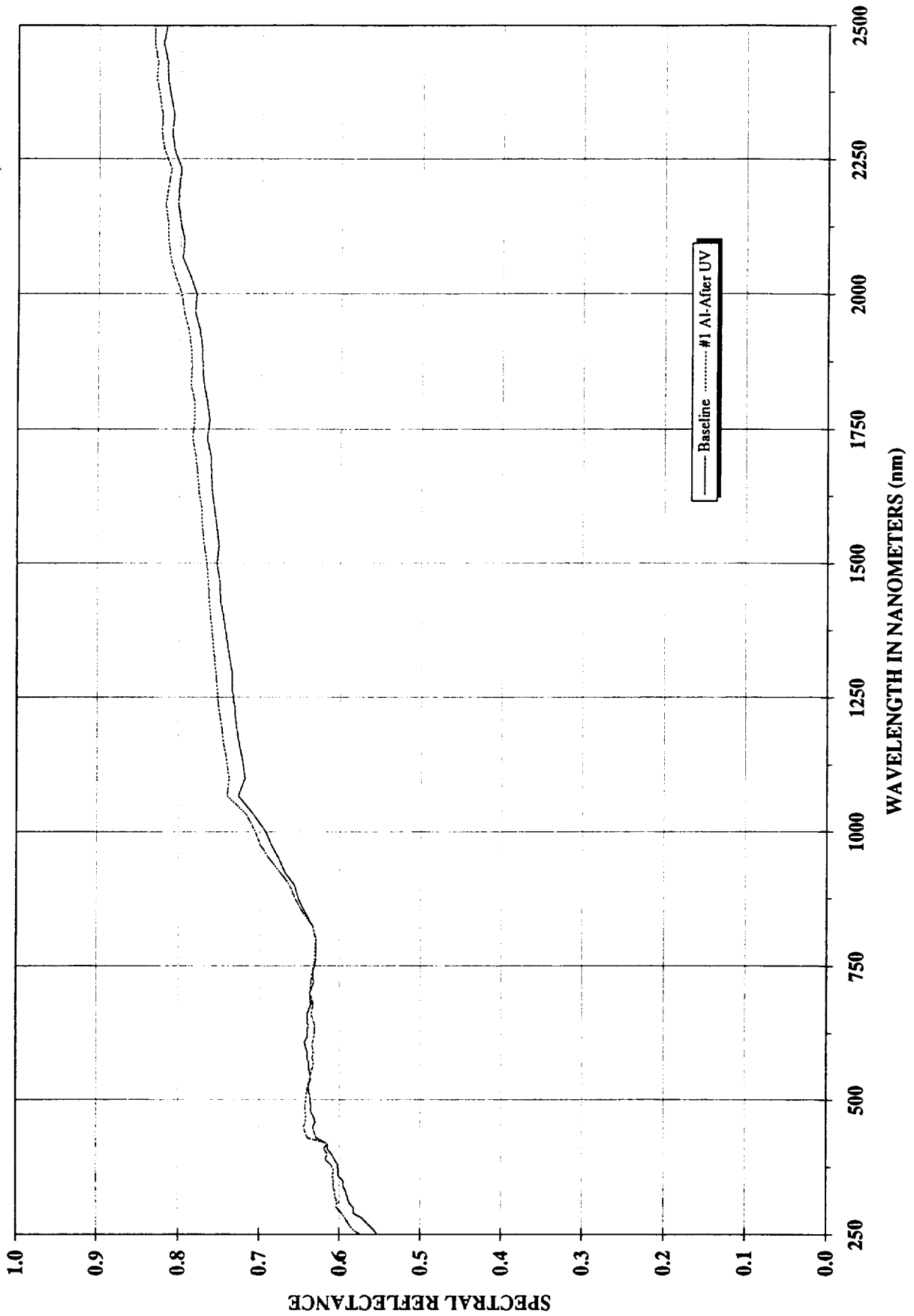

Figure 12. Spectral Reflectance for 2219 Aluminum Sample.

2219 ALUMINUM SAMPLE #2 CONTAMINATION STUDY FOR THE UV VACUUM SYSTEM
BASELINE VS 14 DAYS OF 3 UV SUN EXPOSURE, ALPHA=0.347 BEFORE VS 0.339 AFTER EXPOSURE, LPSR DATA

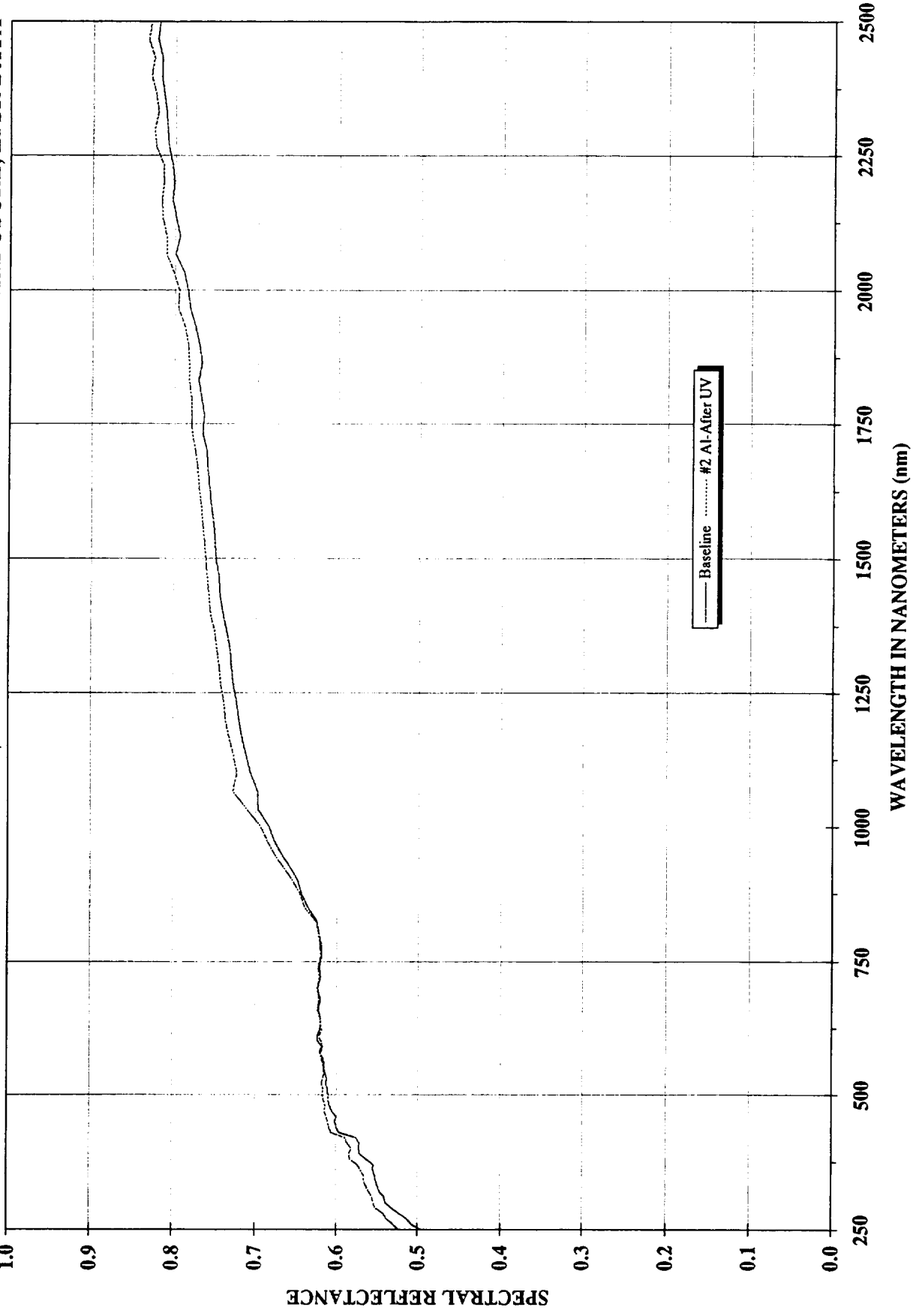

Figure 13. Spectral Reflectance for 2219 Aluminum Sample #2.

**OPTICAL WITNESS SAMPLE #1 CONTAMINATION STUDY FOR UV VACUUM SYSTEM
 BASELINE VS 14 DAYS OF 3 UV SUN EXPOSURE, ALPHA=0.093 BEFORE VS 0.093 AFTER EXPOSURE, LPSR DATA**

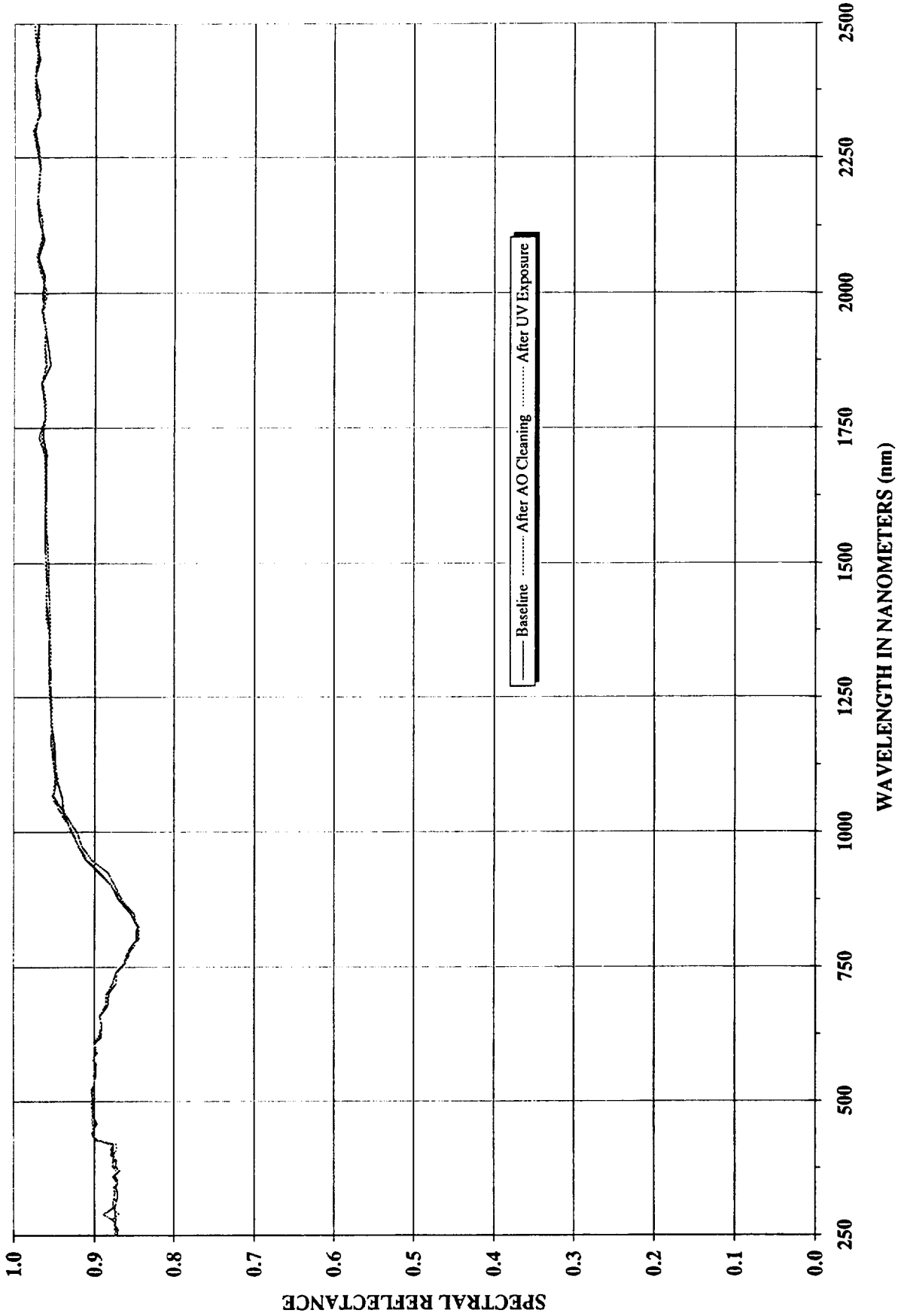

Figure 14. Spectral Reflectance for Optical Witness Sample #1.

**OPTICAL WITNESS SAMPLE #3 CONTAMINATION STUDY FOR UV VACUUM SYSTEM
BASELINE VS 14 DAYS OF 3 UV SUN EXPOSURE, ALPHA=0.092 BEFORE VS 0.093 AFTER EXPOSURE, LPSR DATA**

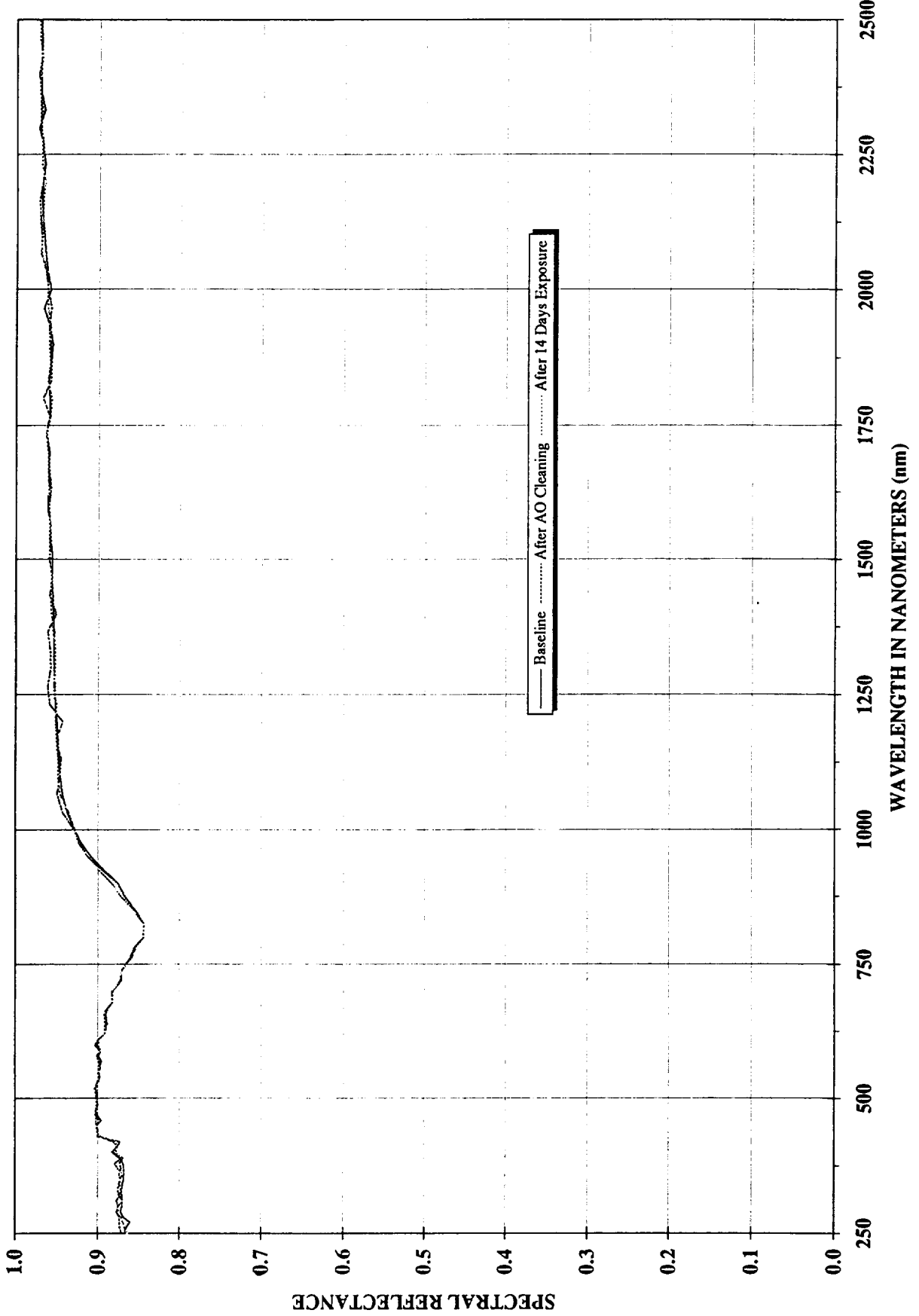
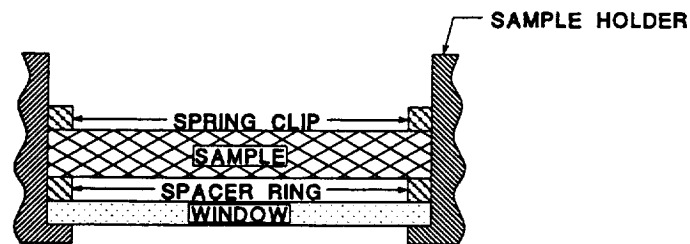

Figure 15. Spectral Reflectance for Optical Witness Sample #3.

2.4 Long Term Study Experimental Procedures

Now that the UV vacuum system was verified free of contamination, we began preparation on the samples for the long term UV study. Four different types of samples were selected for the study. These samples included four one inch Z-93 white diffuse paint discs, four optical witness samples, three one inch 2219 aluminum discs and two chromic anodized aluminum plates. Before the samples were scanned on the LPSR, they were cleaned in Boeings AO system. Once cleaned in the AO system for several hours, spectral reflectance scans were performed. The study included test specimen and one control specimen for each type of material. Before the study began there was high concern about knowing the exact cause of changes in the spectral reflectance. Therefore it was determined that the most effective way in determining true effects of the environment on the various samples was to place windows in front of the samples. Two types of windows were used Pyrex to block the UV rays and fused silica to block any type of contamination that might be introduced into the system during the study. These windows were prevented from touching the surface of the samples by using a 1/16" spacer ring between the window and sample, see figure below.



CUT AWAY VIEW OF THE SAMPLE HOLDER

Figure 16. Cross sectional view of the protected samples.

A total of eight 1 inch discs and one 2" x 6" plate were placed in the sample holder in the configuration shown below. In the configuration, both the optical witness samples and the Z-93 samples were set-up in the same arrangement. This arrangement consisted of one sample with no protection from the environment, one protected with a fused silica window, and one protected with a Pyrex window. This enabled a precise method of determining whether the change in solar absorptivity or spectral reflectance was caused by UV, contamination, or thermal effects.

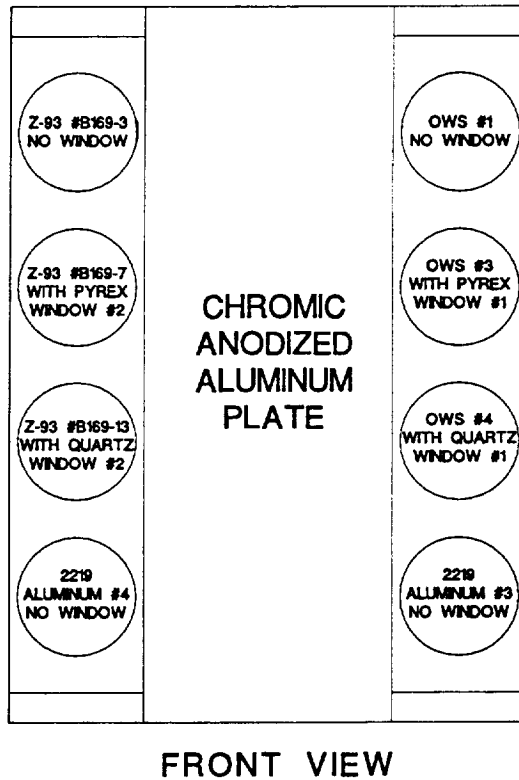

Figure 17. Test Specimen Layout in the Sample Holder

The samples were placed in the UV vacuum system on January 5, 1995. The ion pumps were allowed to pump on the system overnight to insure that any contaminants were drawn into the ion pump. The mercury-xenon lamp was turned on January 6, 1995 at 5:00 p.m. indicative of an output of 3.0 UV suns. The lamp continued to run at 3 UV suns until January 27, 1995 at 3:00 p.m. when the lamp failed. The lamp was replaced and the study continued on February 3, 1995 at 4:10 p.m. The lamp was not calibrated until February 16, 1995. It was found that the lamps output was 4.92 UV suns.

2.4.1 Evaluation of Spacecraft Materials

On February 16, 1995, the samples were removed from U.A.H.'s UV vacuum system after being exposed to UV radiation for 2923 hours or 121.8 days. A spectral reflectance scan was performed on all of the exposed samples including the controls and windows using the LPSR. Upon examination of the spectral reflectance graphs, definite changes occurred in the Z-93 white diffused paint, chromic anodized aluminum, and the Pyrex windows. in the ultra-violet and visible regions of the spectrum. The spectral reflectance graphs for both the test and control specimen are on the following pages.

OPTICAL WITNESS SAMPLE #1 UV EXPOSURE STUDY - LPSR DATA
BASELINE VS. 6 WEEKS EXPOSURE, ALPHA=0.093 BEFORE AND 0.093 AFTER EXPOSURE
OWS #1 WAS NOT PROTECTED WITH A WINDOW DURING UV EXPOSURE

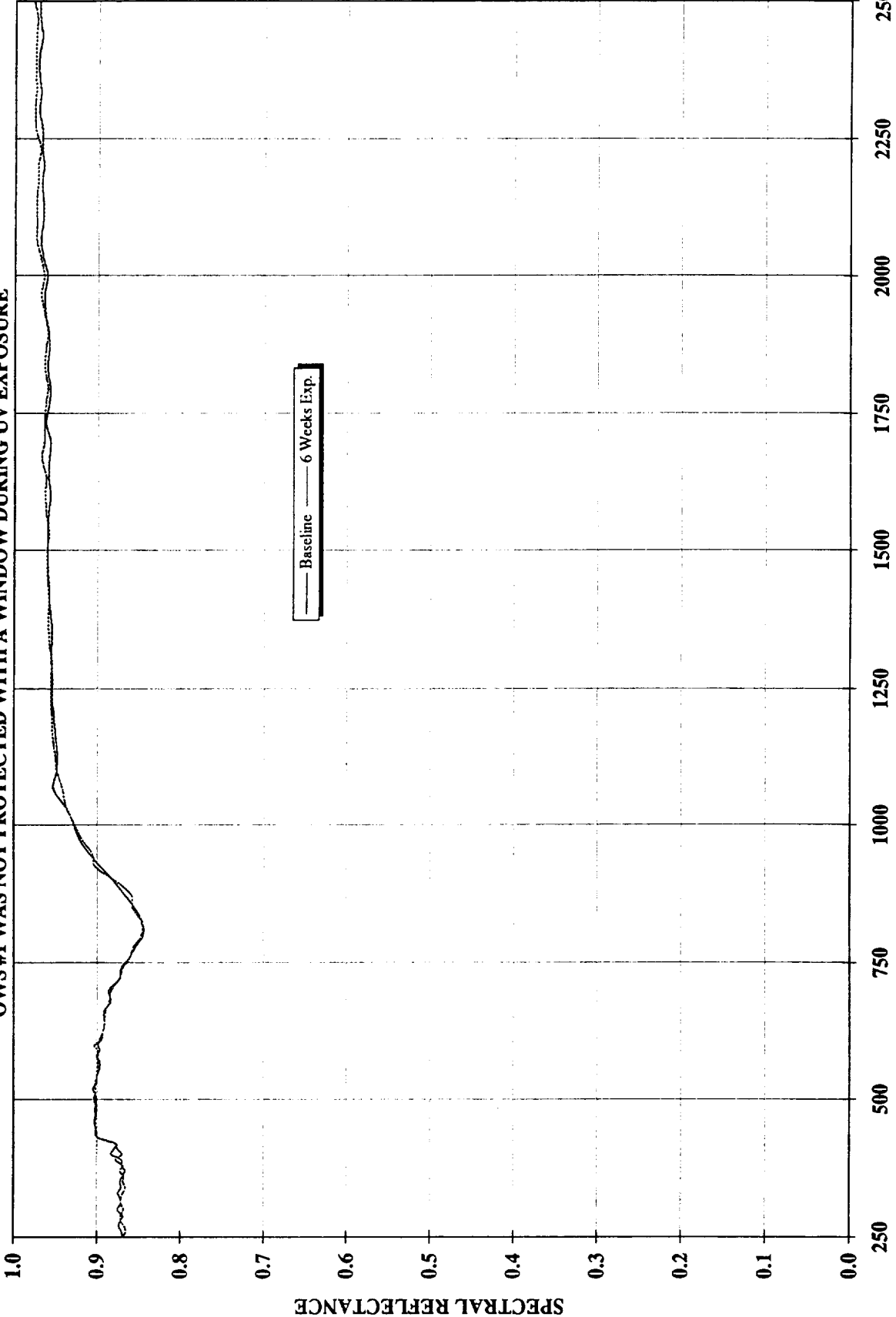

File: OWS.XLS
 Data Taken: 1/5/95, 2/16/95

Figure 18. Optical Witness Sample #1 Before and After Exposure.

OPTICAL WITNESS SAMPLE #3 UV EXPOSURE STUDY - LPSR DATA
BASELINE VS 6 WEEKS OF UV EXPOSURE, ALPHA=0.094 BEFORE VS 0.093 AFTER EXPOSURE
OWS #3 PROTECTED WITH A PYREX WINDOW DURING UV EXPOSURE

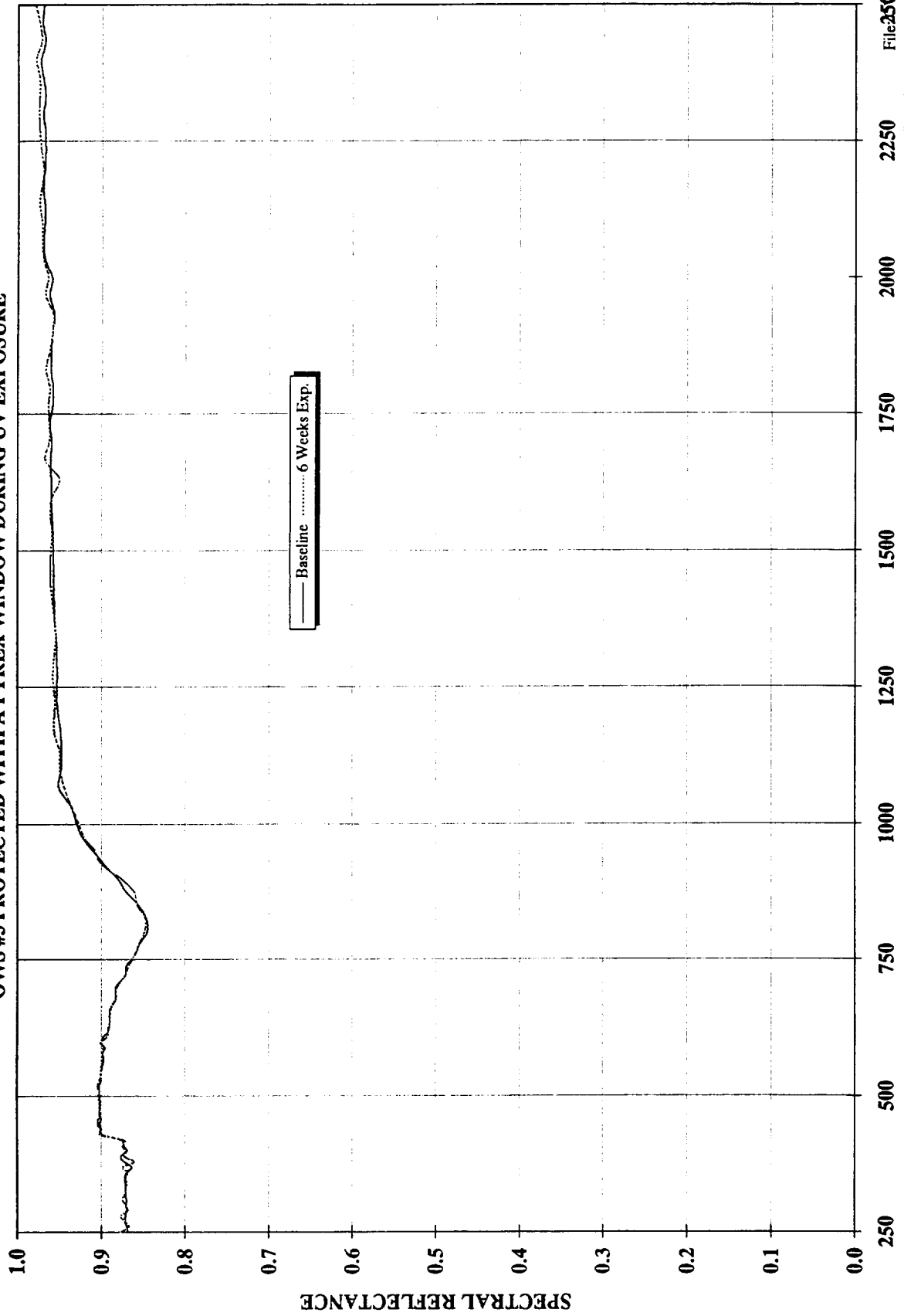

File: 2500.XLS
Data Taken: 1/5/95, 2/16/95

WAVELENGTH IN NANOMETERS (nm)

Figure 19. Optical Witness Sample #3 Before and After Exposure.

OPTICAL WITNESS SAMPLE #4 UV EXPOSURE STUDY - LPSR DATA
BASELINE VS 6 WEEKS OF UV EXPOSURE, ALPHA=0.093 BEFORE VS 0.094 AFTER EXPOSURE
OWS #4 PROTECTED WITH A QUARTZ WINDOW DURING UV EXPOSURE

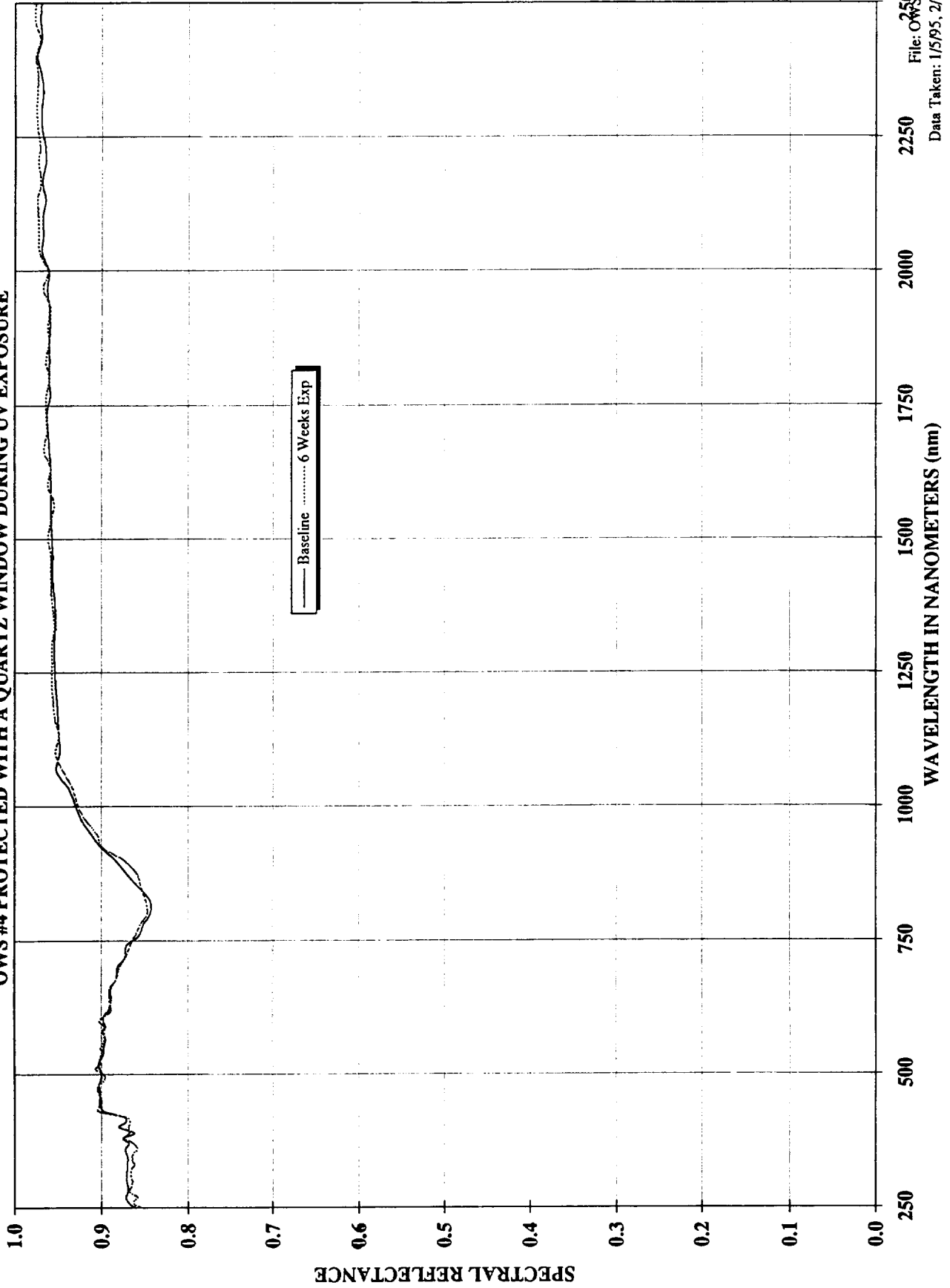

2500
File: OWS.XLS
Data Taken: 1/5/95, 2/16/95

Figure 20. Optical Witness Sample #4 Before and After Exposure.

2219 ALUMINUM SAMPLE #3 UV EXPOSURE STUDY - LPSR DATA
BASELINE VS 6 WEEKS EXPOSURE, ALPHA=0.375 BEFORE VS 0.373 AFTER EXPOSURE
2219 AL #3 WAS NOT PROTECTED WITH A WINDOW DURING UV EXPOSURE

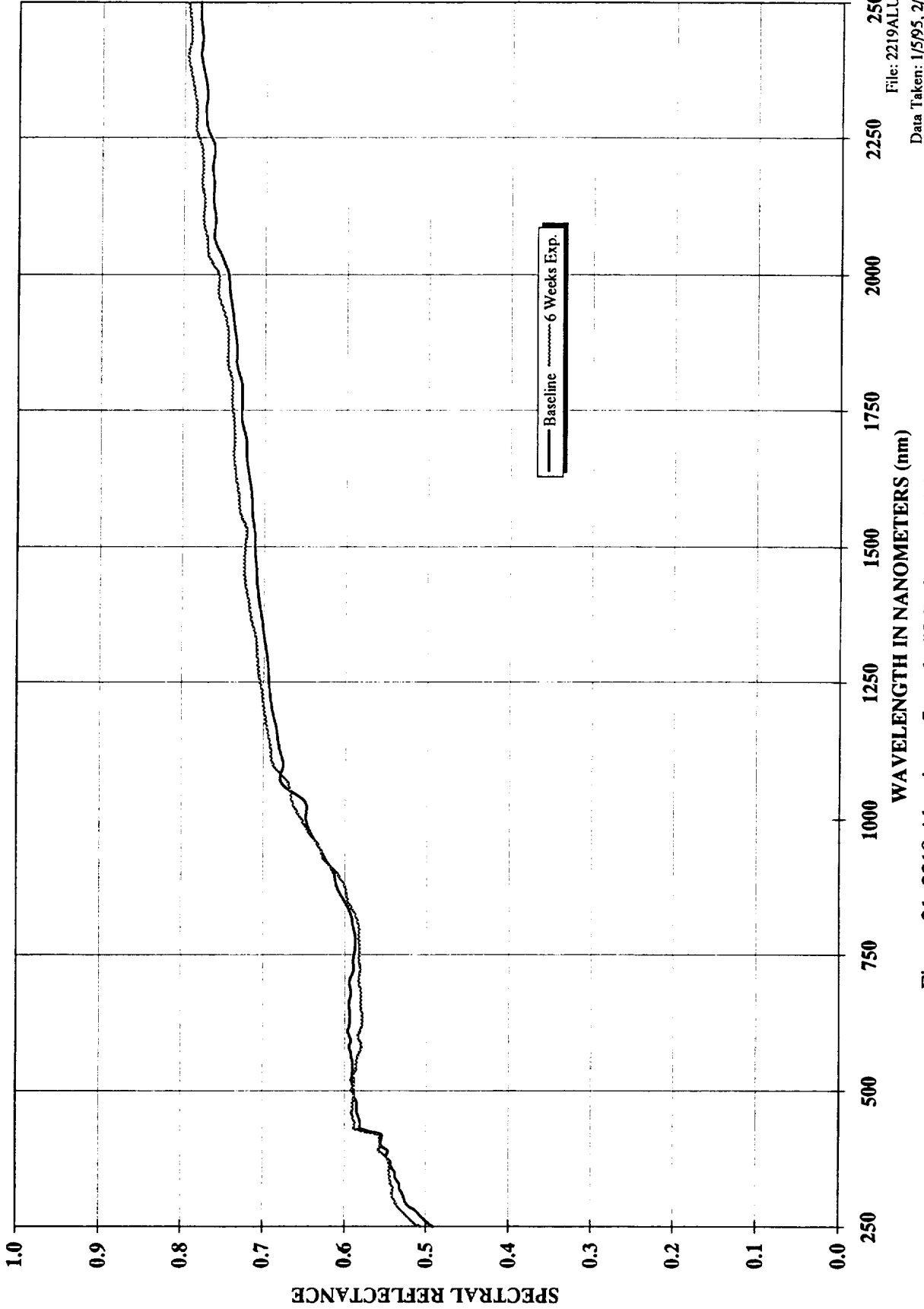
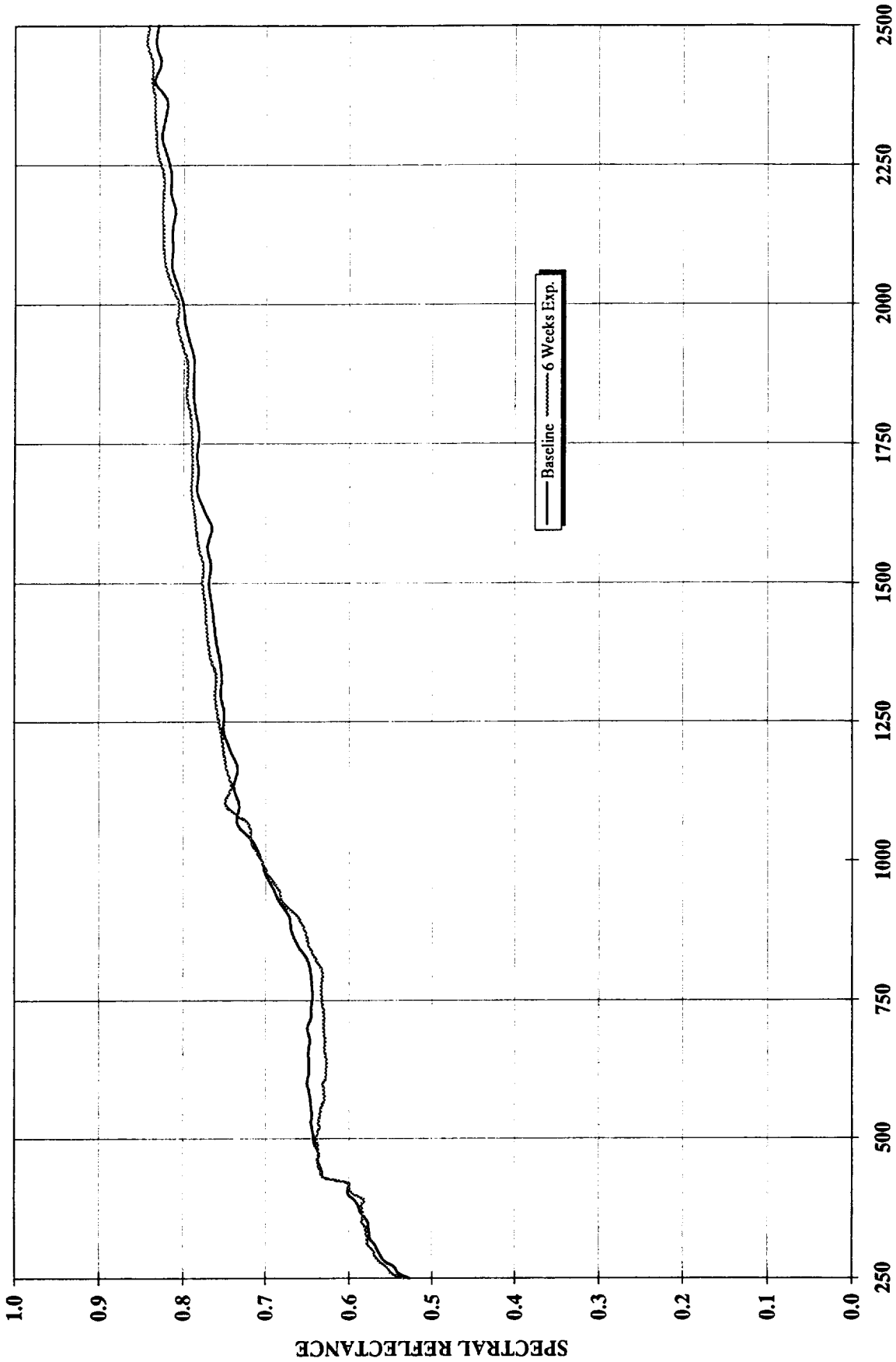

Figure 21. 2219 Aluminum Sample #3 Before and After UV Exposure.

File: 2219ALU.XLS
Data Taken: 1/5/95, 2/16/95

2219 ALUMINUM SAMPLE #4 UV EXPOSURE STUDY - LPSR DATA
BASELINE VS 6 WEEKS EXPOSURE, ALPHA=0.322 BEFORE VS 0.325 AFTER EXPOSURE
2219 AL #4 WAS NOT PROTECTED WITH A WINDOW DURING UV EXPOSURE



File: 2219AL.XLS
Data Taken: 1/05/95, 2/16/95

Figure 22. 2219 Aluminum Sample #4 Before and After UV Exposure.

Z-93 WHITE DIFFUSE PAINT SAMPLE #B169-3 UV EXPOSURE STUDY - LPSR DATA
BASELINE VS 6 WEEKS EXPOSURE, ALPHA=0.157 BEFORE VS 0.163 AFTER EXPOSURE
Z-93 #B169-3 WAS NOT PROTECTED WITH A WINDOW DURING UV EXPOSURE

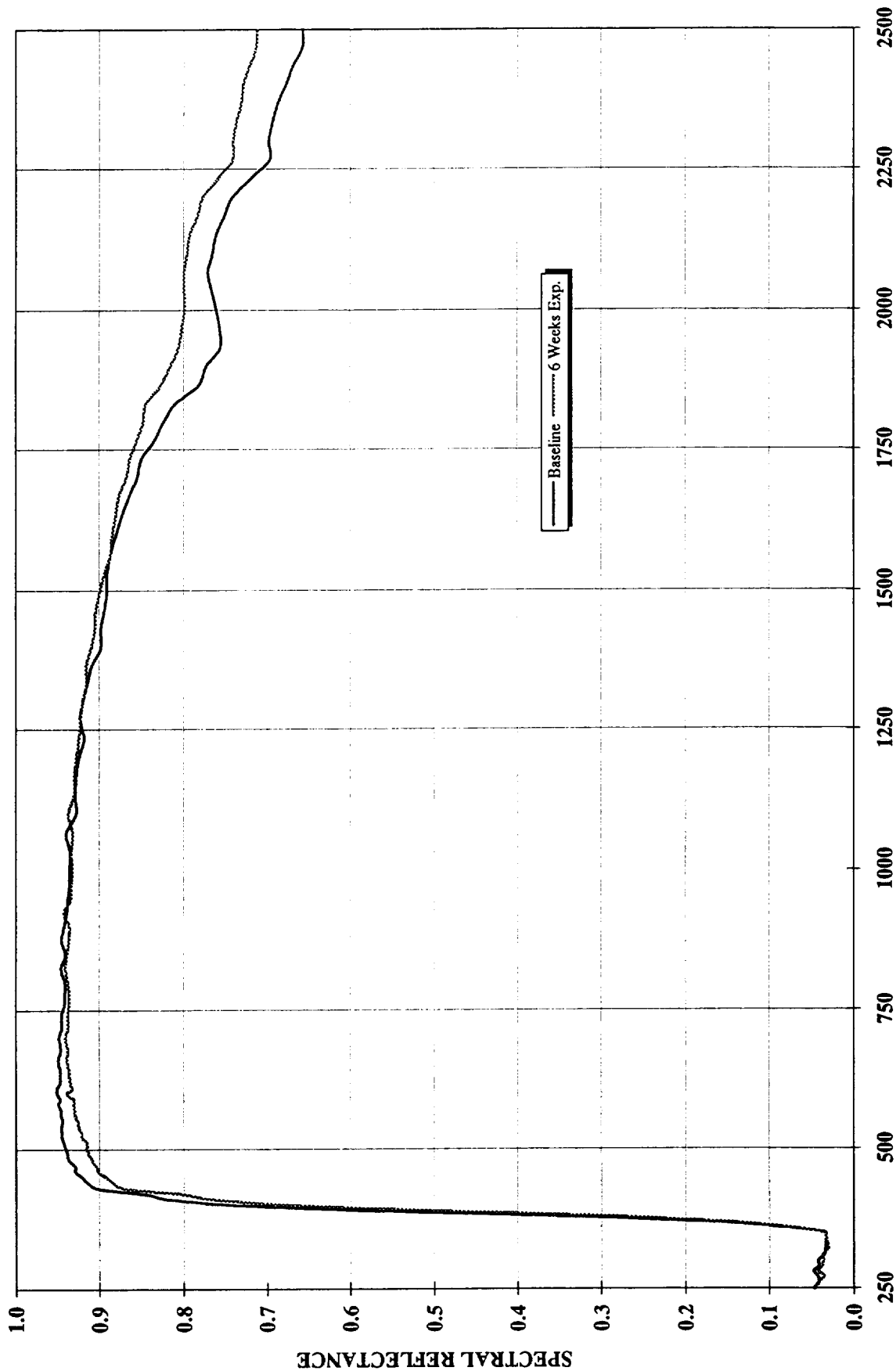

Figure 23. Z-93 White Diffuse Paint Sample #B169-3 Before and After Exposure.

Z-93 WHITE DIFFUSE PAINT SAMPLE #B169-7 UV EXPOSURE STUDY - LPSR DATA
BASELINE VS 6 WEEKS EXPOSURE, ALPHA=0.155 BEFORE VS 0.150 AFTER EXPOSURE
Z-93 #B169-7 PROTECTED WITH A PYREX WINDOW #2 DURING UV EXPOSURE

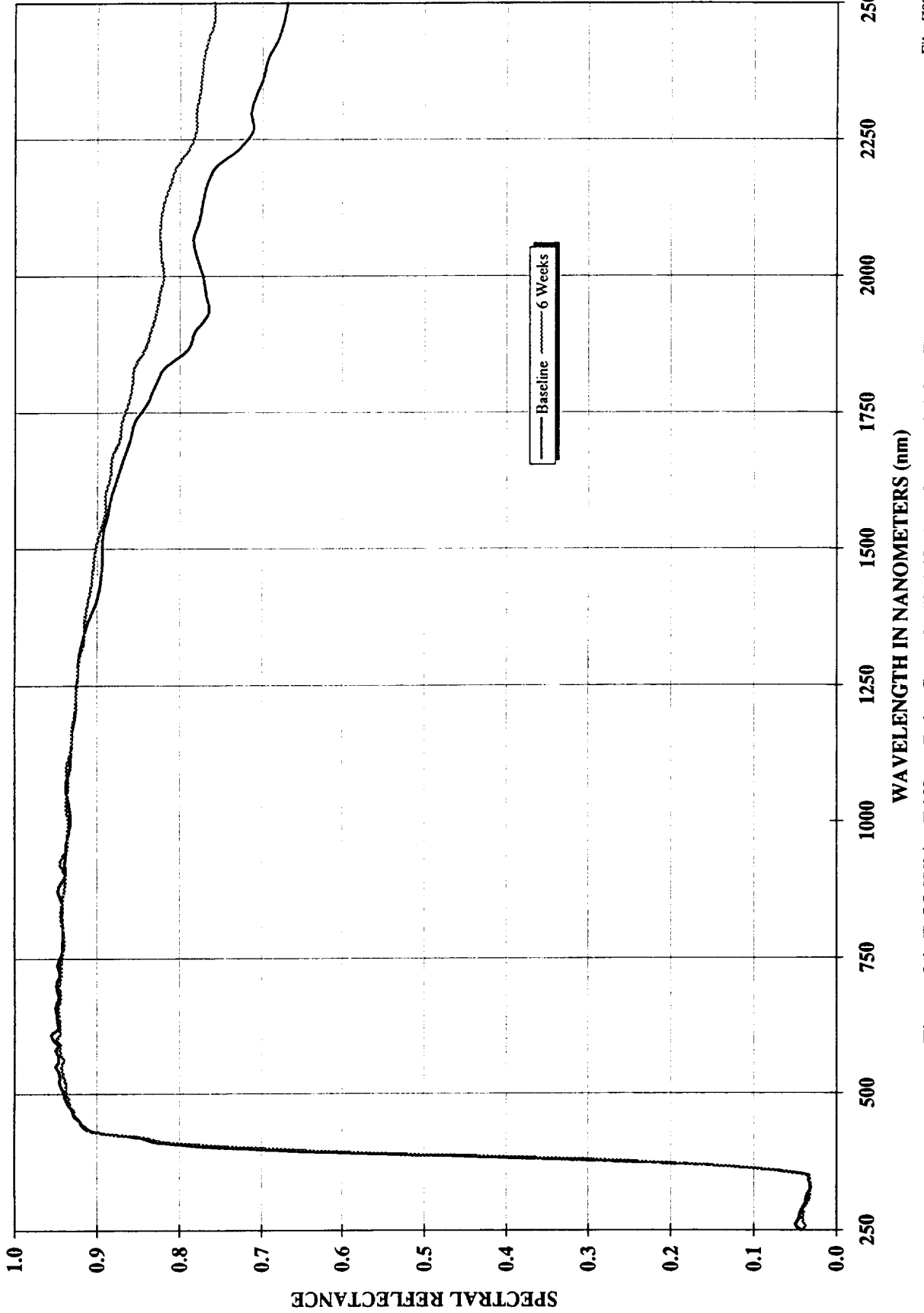

Figure 24. Z-93 White Diffuse Paint Sample #B169-7 Before and After Exposure.

Z-93 WHITE DIFFUSE PAINT SAMPLE #B169-13 UV EXPOSURE STUDY - LPSR DATA
BASELINE VS 6 WEEKS EXPOSURE, ALPHA=0.157 BEFORE VS 0.159 AFTER EXPOSURE
Z-93 #B169-13 PROTECTED WITH QUARTZ WINDOW #2 DURING UV EXPOSURE

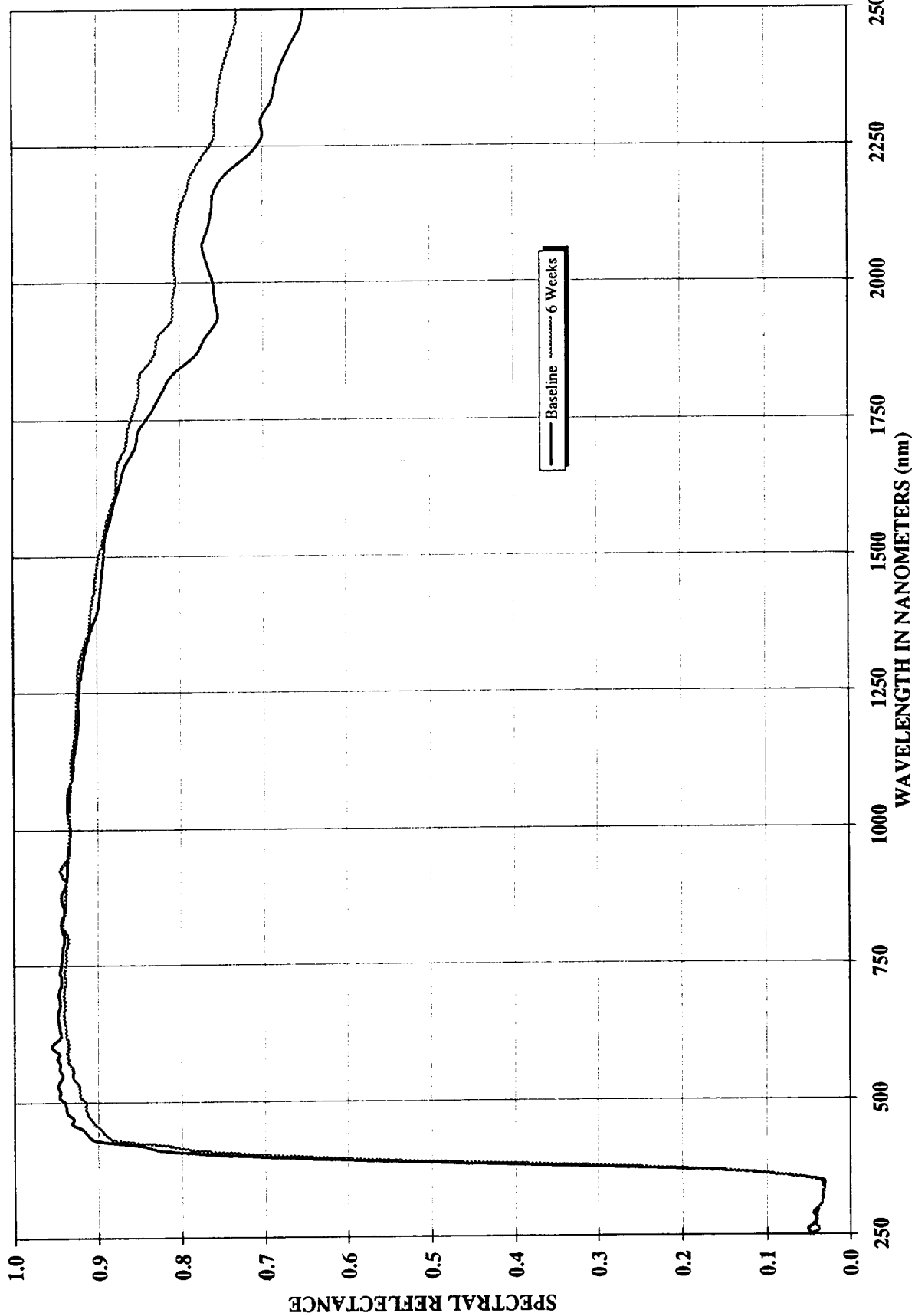

Figure 25. Z-93 White Diffuse Paint Sample #B169-13 Before and After UV Exposure.

CHROMIC ANODIZED ALUMINUM SAMPLE II-6 UV EXPOSURE STUDY - LPSR DATA
BASELINE VS 6 WEEKS EXPOSURE, ALPHA=0.362 BEFORE VS 0.372 AFTER EXPOSURE
TOP SCAN OF CAA PLATE

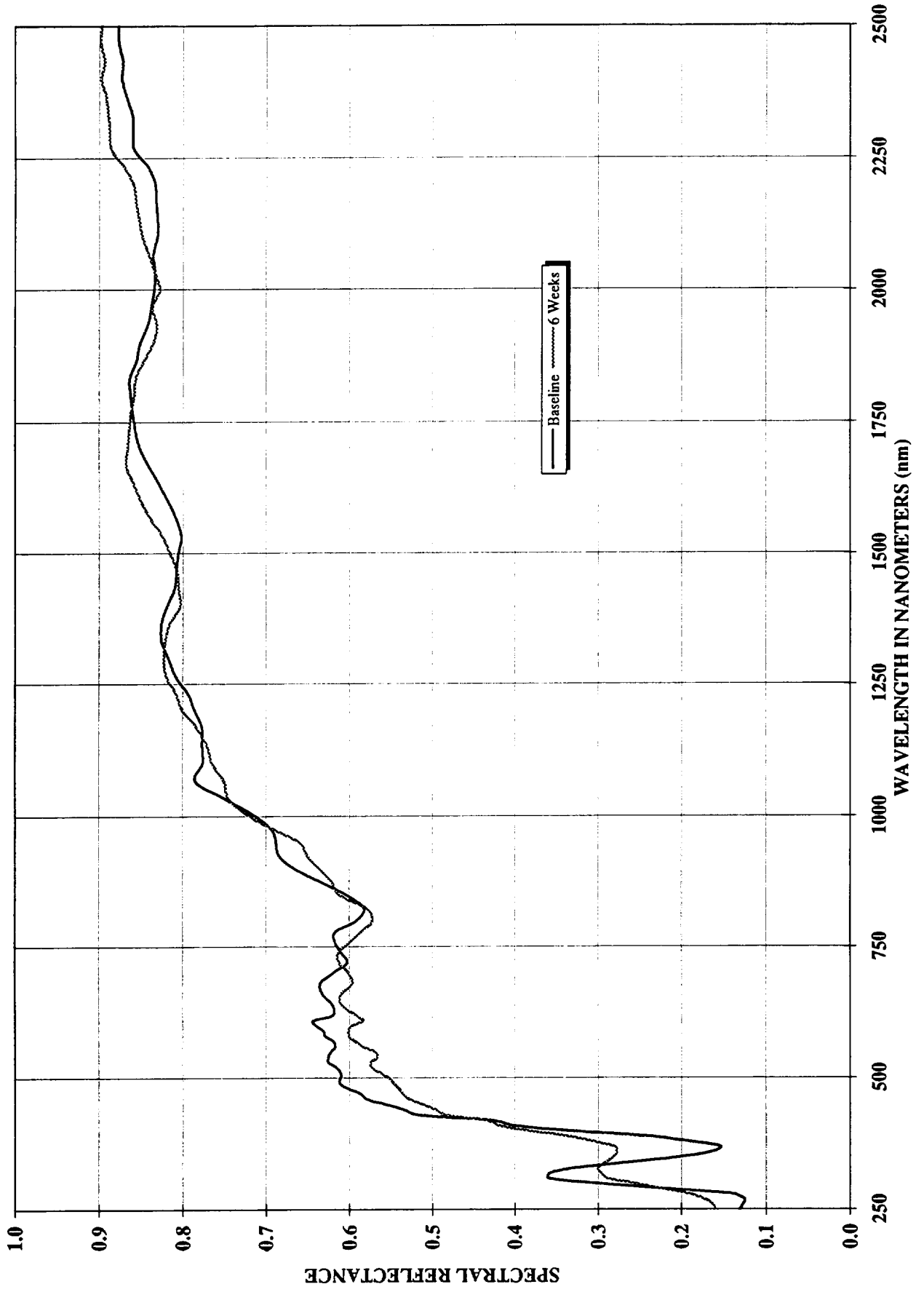

Figure 26. CAA Sample II-6 Top Scan Before and After UV Exposure.

CHROMIC ANODIZED ALUMINUM SAMPLE II-6 UV EXPOSURE STUDY - LPSR DATA
BASELINE VS 6 WEEKS EXPOSURE, ALPHA=0.364 BEFORE VS 0.373 AFTER EXPOSURE
CENTER SCAN OF CAA PLATE

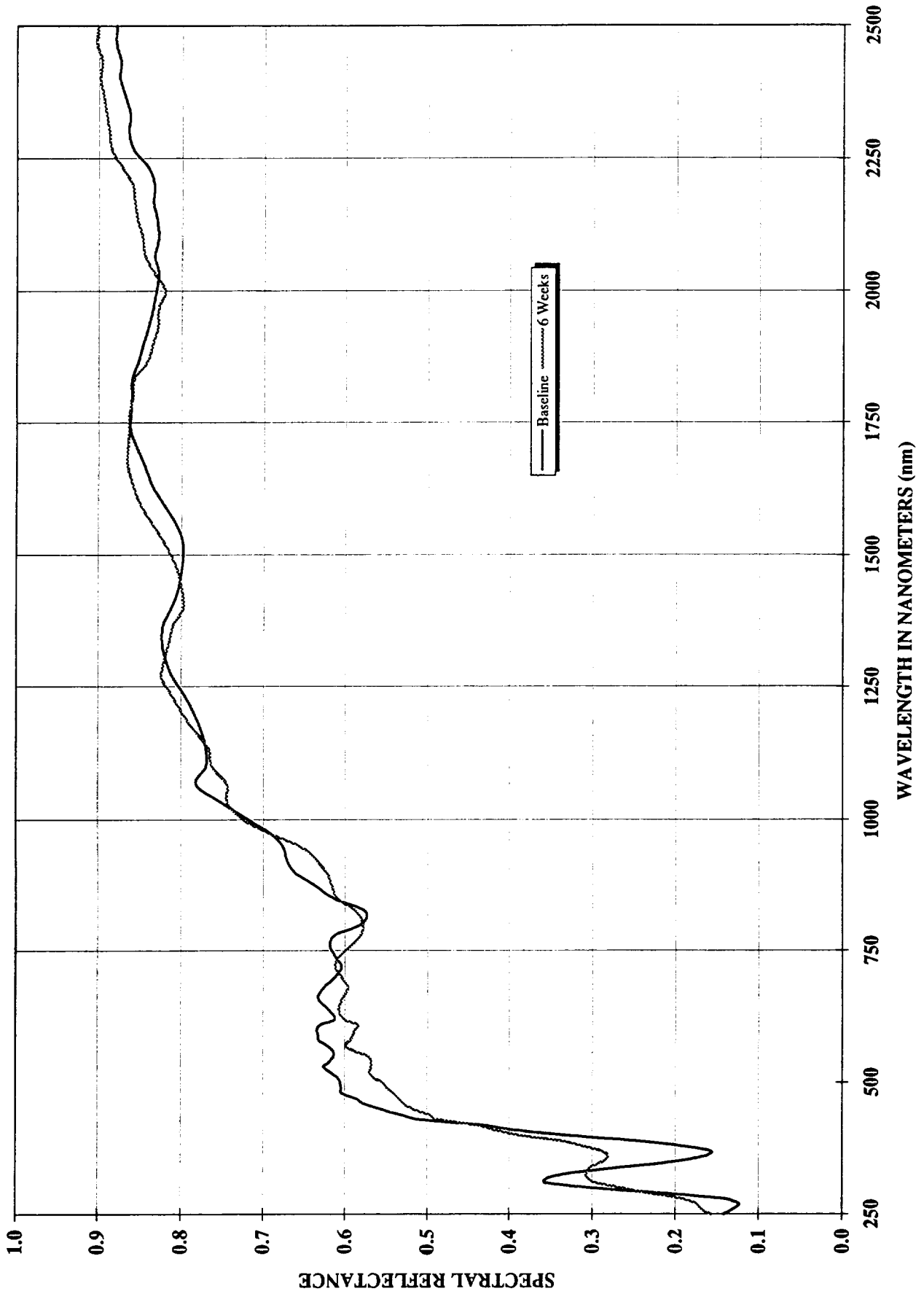

Figure 27. CAA Sample II-6 Center Scan Before and After UV Exposure.

CHROMIC ANODIZED ALUMINUM SAMPLE II-6 UV EXPOSURE STUDY - LPSR DATA

BASELINE VS 6 WEEKS EXPOSURE, ALPHA=0.357 BEFORE VS 0.368 AFTER EXPOSURE

BOTTOM SCAN OF CAA PLATE

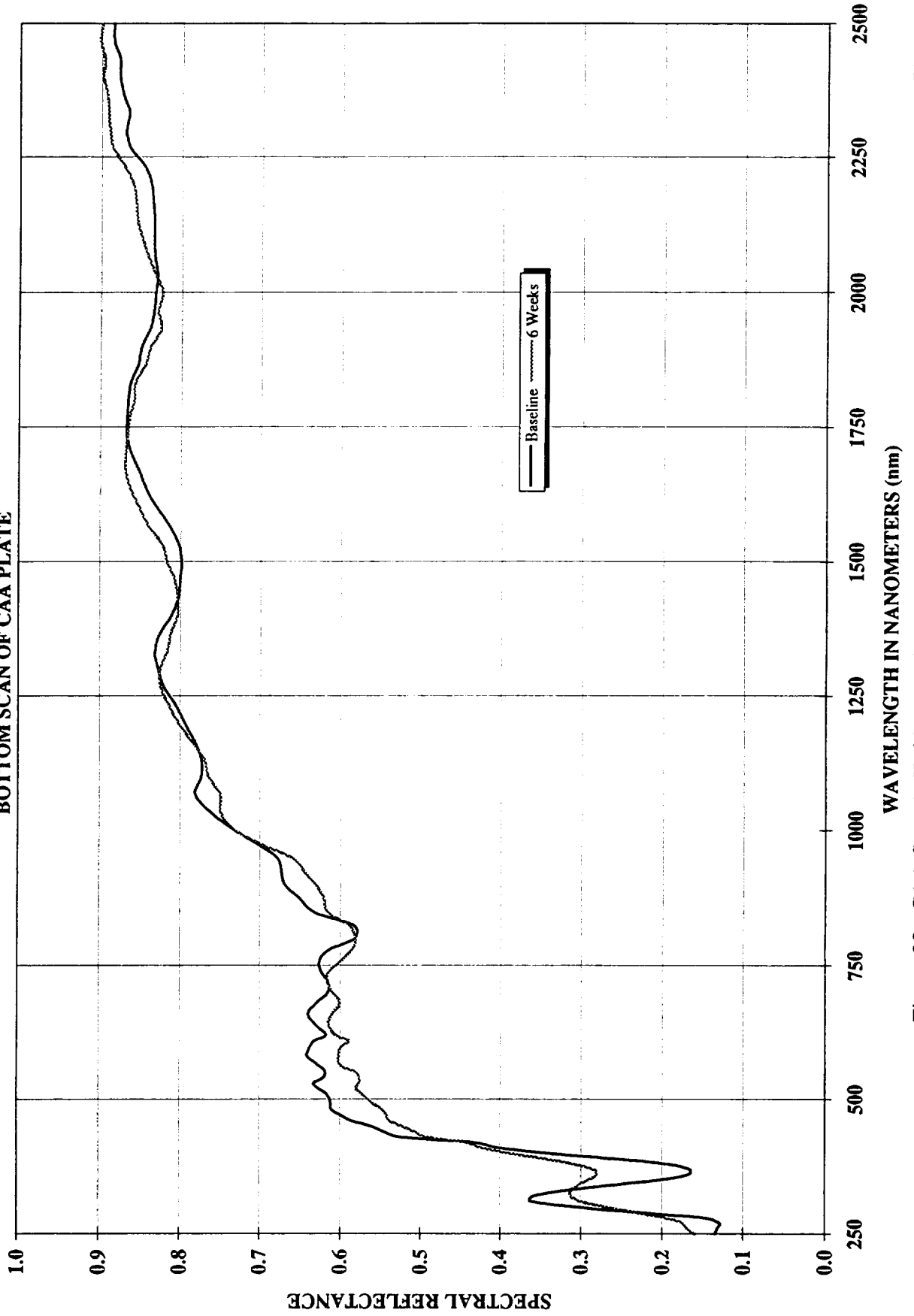

Figure 28. CAA Sample II-6 Bottom Scan Before and After UV Exposure.

PYREX WINDOW #1 UV EXPOSURE STUDY - LPSR DATA
BASLINE VS 6 WEEKS EXPOSURE, ALPHA=0.137 BEFORE VS 0.140 AFTER EXPOSURE
PYREX WINDOW #1 PROTECTED OWS #3 DURING UV EXPOSURE

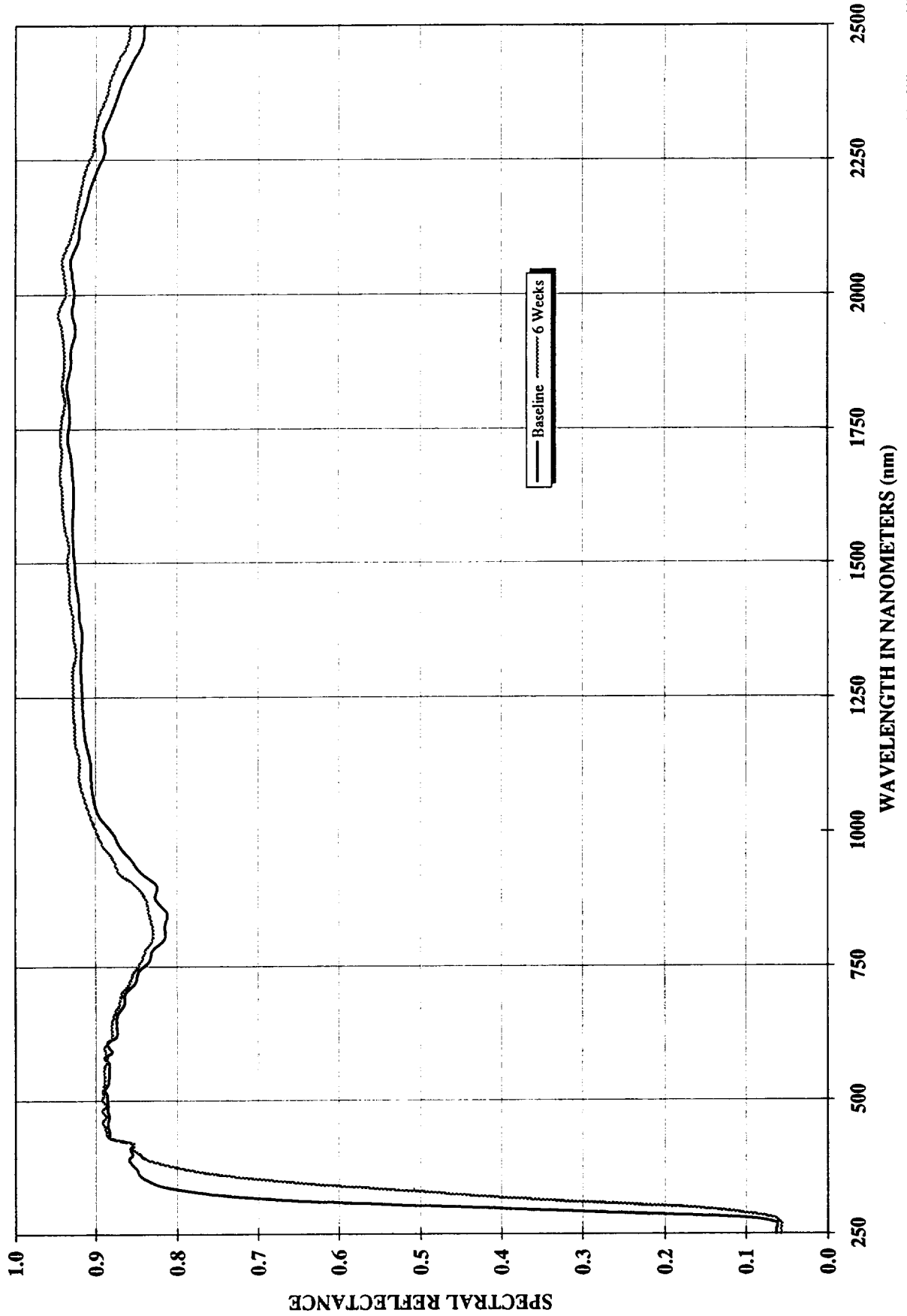
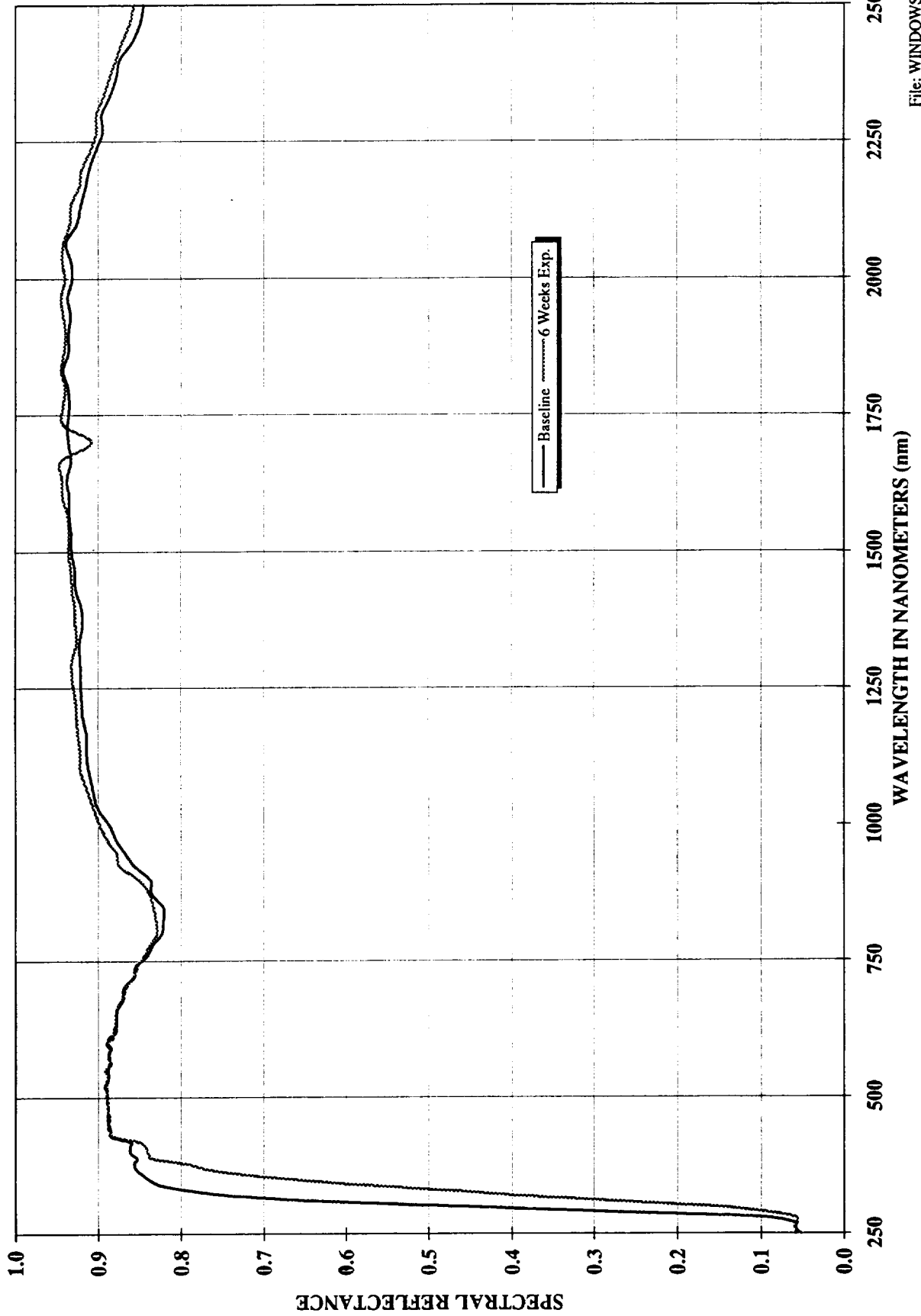

Figure 29. Pyrex Window #1 Before and After UV Exposure.

PYREX WINDOW #2 UV EXPOSURE STUDY - LPSR DATA
BASELINE VS 6 WEEKS EXPOSURE, ALPHA=0.133 VS 0.143 AFTER EXPOSURE
PYREX WINDOW #2 PROTECTED Z-93 #B169-7 SAMPLE DURING UV EXPOSURE



File: WINDOWS.XLS
Data Taken: 1/5/95, 2/16/95

Figure 30. Pyrex Window #2 Before and After UV Exposure.

FUSED SILICA WINDOW #1 UV EXPOSURE STUDY - LPSR DATA

BASELINE VS 6 WEEKS EXPOSURE, ALPHA=0.104 BEFORE VS 0.101 AFTER EXPOSURE

FUSED SILICA WINDOW #1 PROTECTED OWS #4 DURING UV EXPOSURE

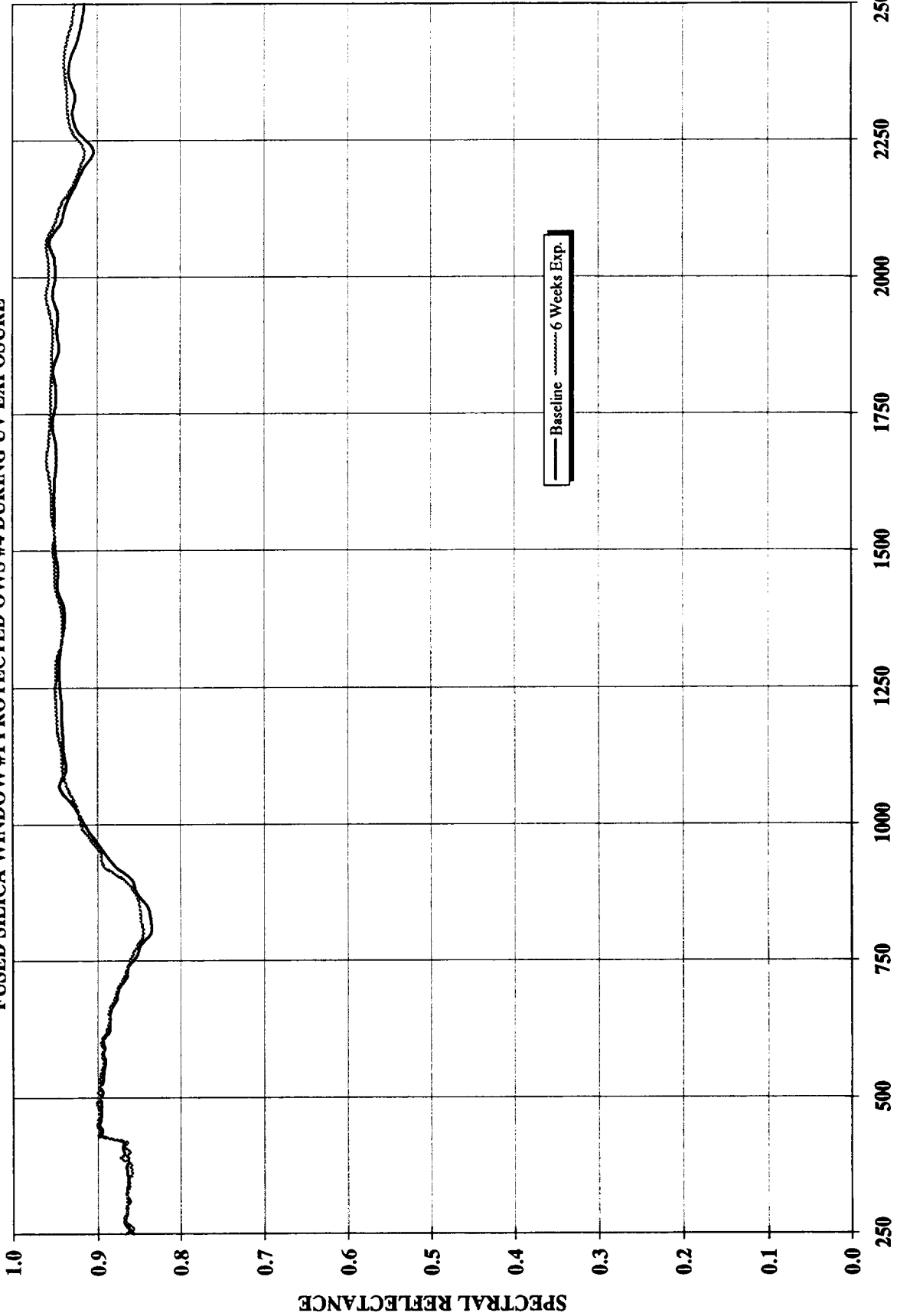

WAVELENGTH IN NANOMETERS (nm)

Figure 31. Fused Silica Window #1 Before and After UV Exposure.

FUSED SILICA WINDOW #2 UV EXPOSURE STUDY - LPSR DATA
BASELINE VS. 6 WEEKS EXPOSURE, ALPHA=0.103 BEFORE AND 0.103 AFTER EXPOSURE
FUSED SILICA WINDOW #2 PROTECTED Z-93 #B169-13 SAMPLE DURING UV EXPOSURE

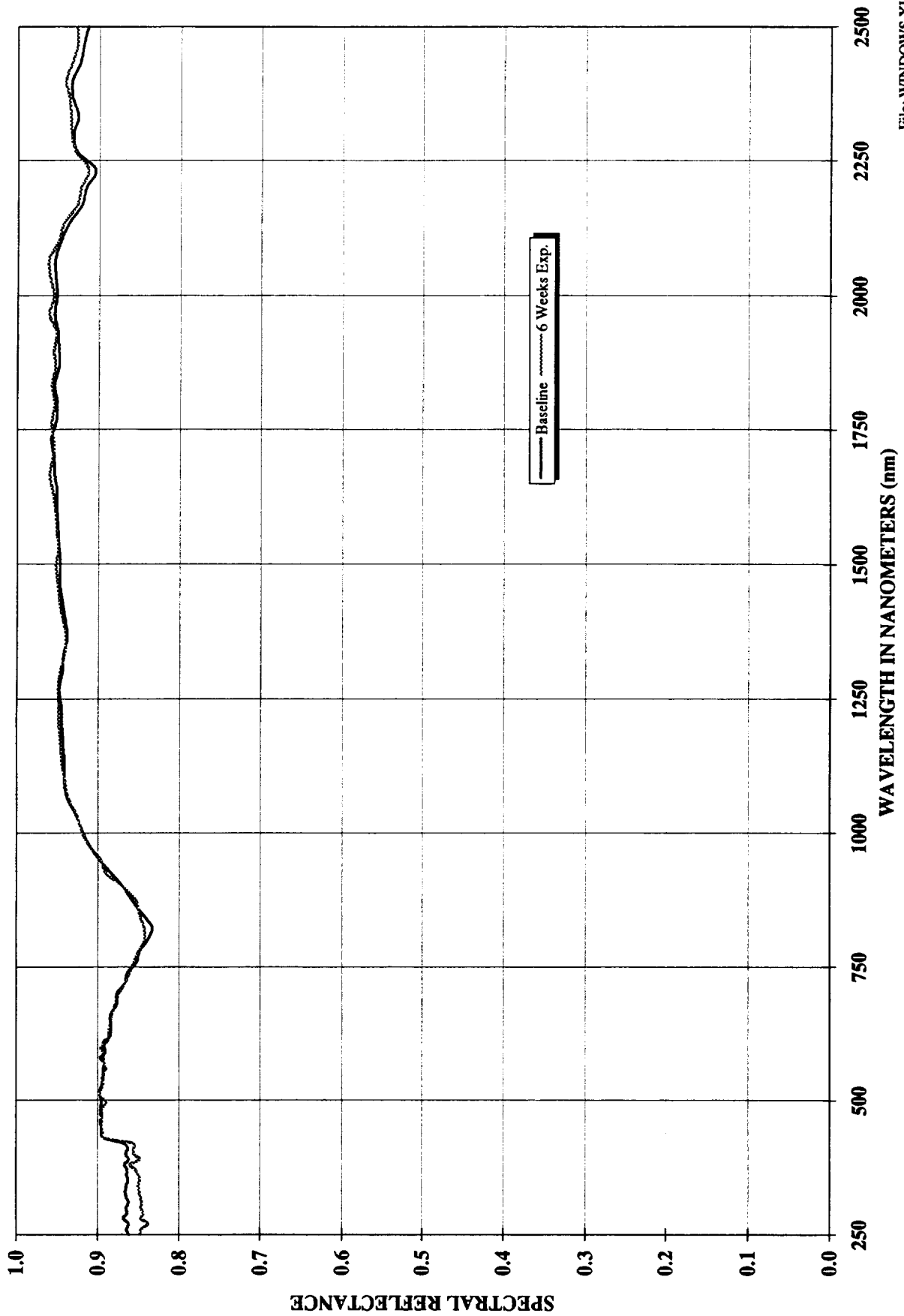

Figure 32. Fused Silica Window #2 Before and After UV Exposure.

OPTICAL WITNESS CONTROL SAMPLE #2 UV EXPOSURE STUDY - LPSR DATA

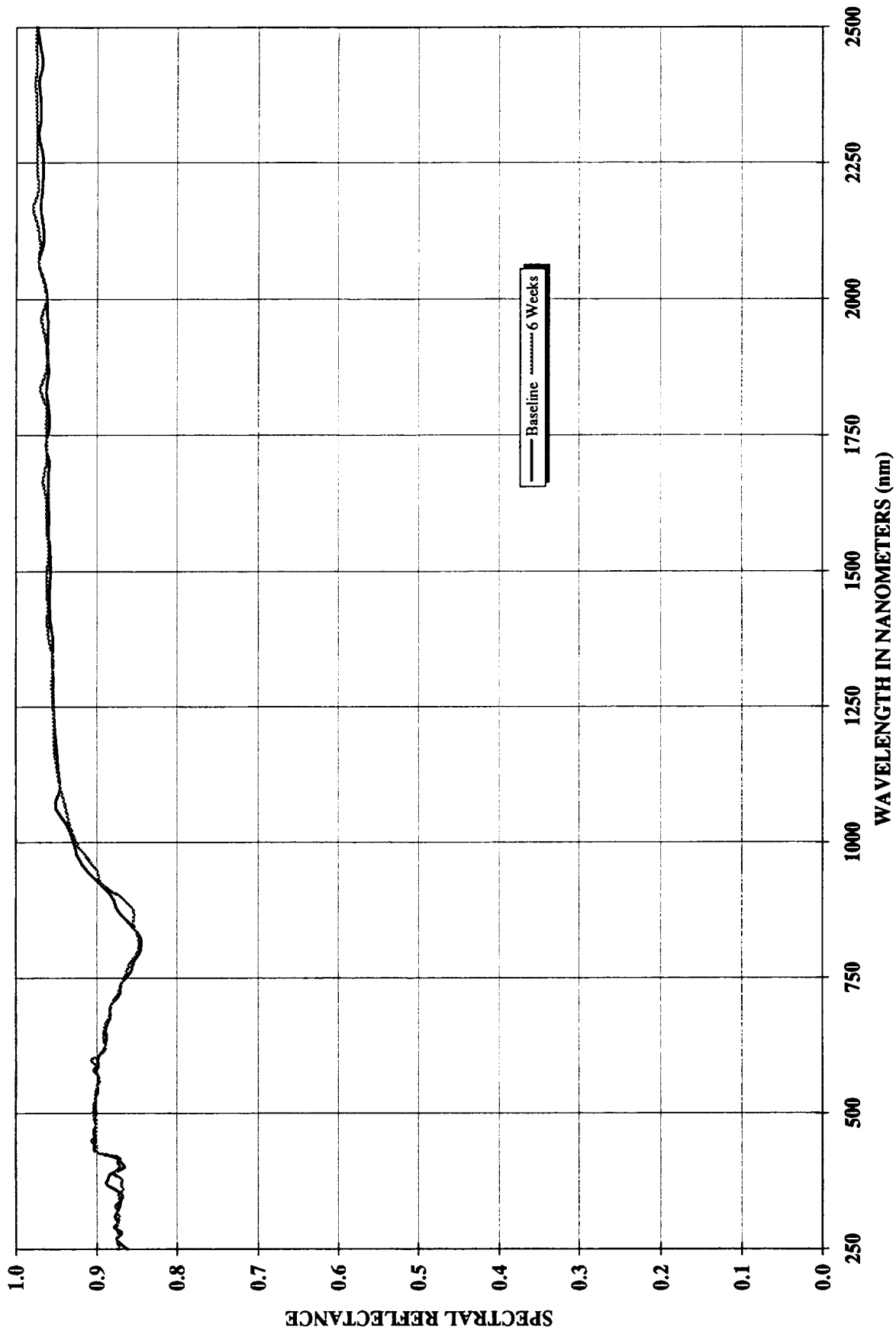
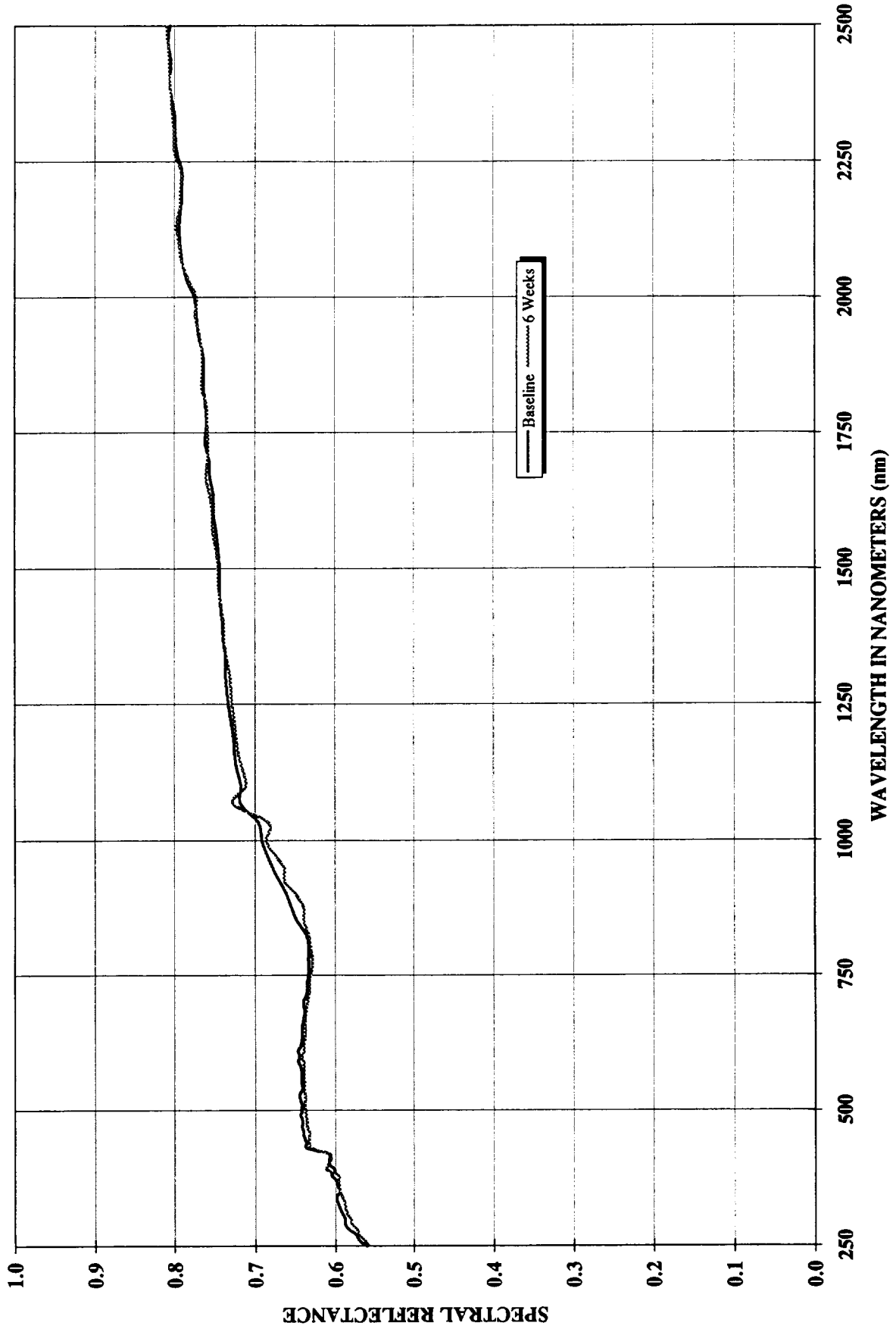

Figure 33. Optical Witness Control Sample #2

2219 ALUMINUM CONTROL SAMPLE #5 UV EXPOSURE STUDY - LPSR DATA



File: CONTROLS.XLS
Data Taken: 1/5/95, 2/16/95

Figure 34. 2219 Aluminum Control Sample #5

Z-93 WHITE DIFFUSE PAINT #B169-1 CONTROL UV EXPOSURE STUDY - LPSR DATA

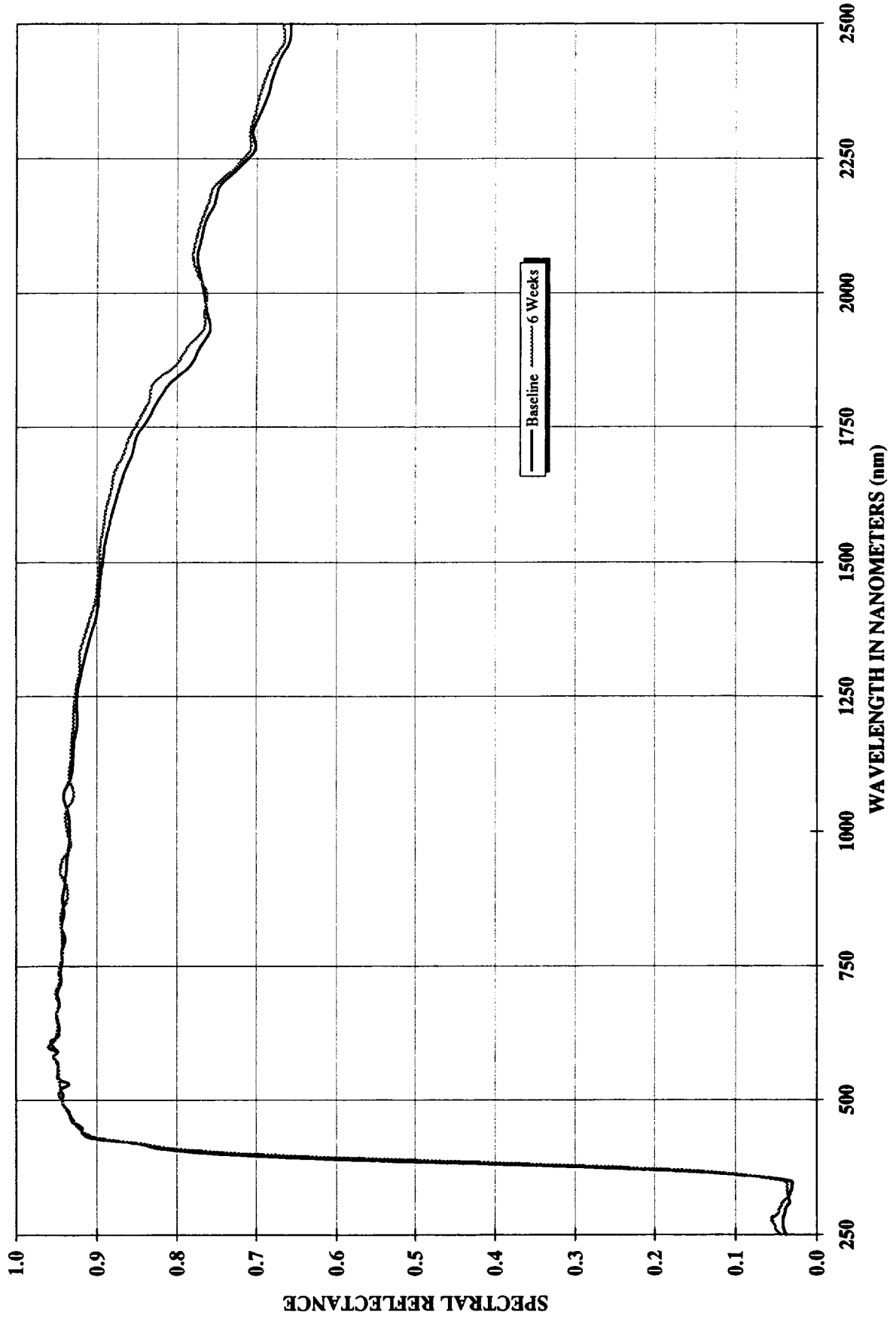

Figure 35. Z-93 White Diffuse Paint Control Sample #B169-1

CHROMIC ANODIZED ALUMINUM CONTROL SAMPLE II-6C UV EXPOSURE STUDY - LPSR DATA

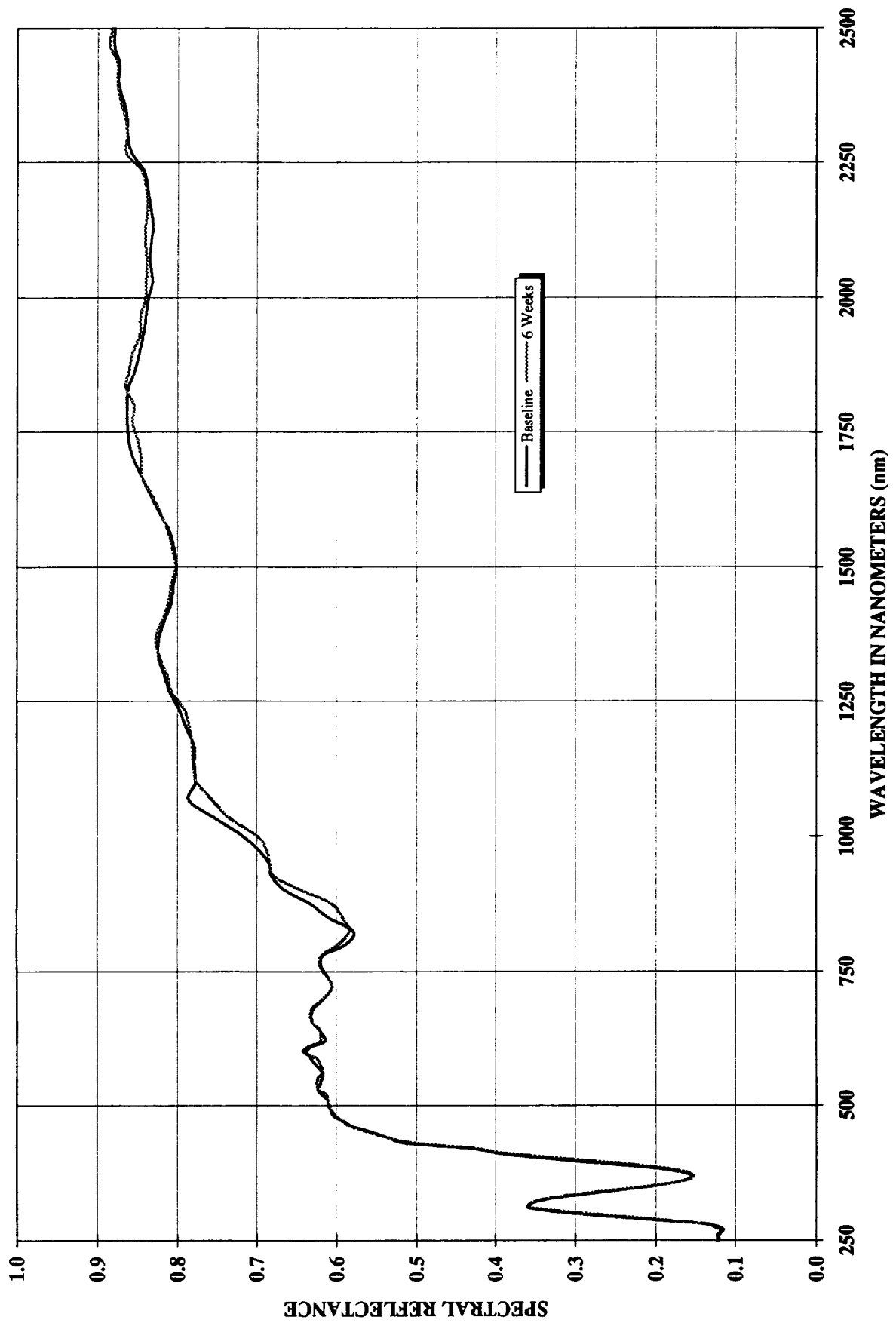

Figure 36. CAA Control Sample II-6C

FUSED SILICA CONTROL WINDOW #3 UV EXPOSURE STUDY - LPSR DATA

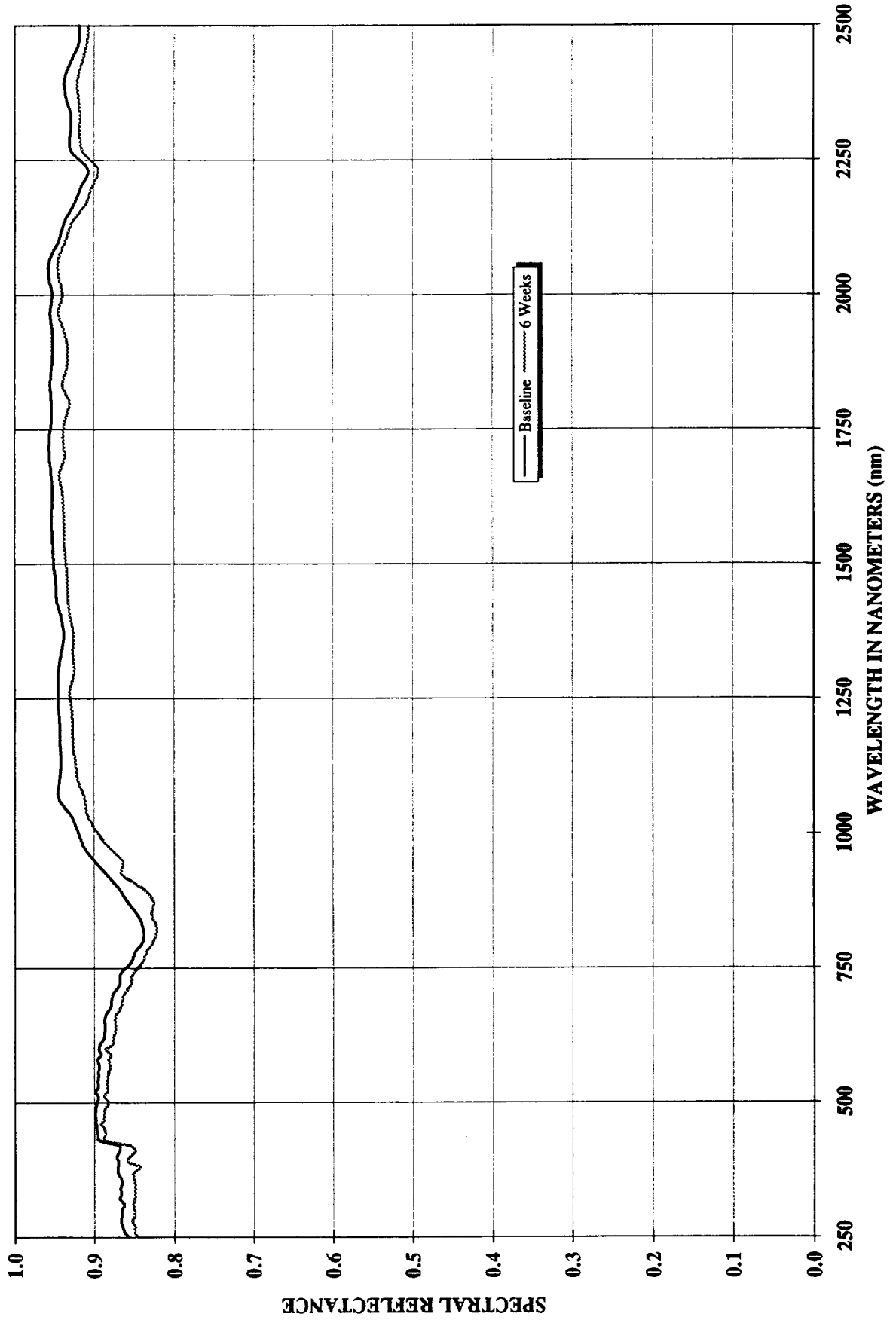

Figure 37. Fused Silica Control Window #3

3.0 LPSR STANDOFF STUDY

In studying the characteristics of the LPSR, it is critical to know the effect of standoff distance on the solar reflectance of various samples. Standoff refers to the distance between the sample and the measurement aperture of the LPSR. Standoff distance becomes an issue when the sample can not be touched with the measurement aperture of the LPSR because of contamination issues or physical constraints.

3.1 Experimental Procedures

To determine the effects of standoff distance verses solar absorption and reflectance, several runs were made using the LPSR with various samples (gold mirror, Mg-FI mirror, S13G/LO white diffused paint, 304 stainless and Spectralon). The standoff distances were increased in 0.25 mm increments from the measurement aperture using a computer driven servo system. The standoff distance was increased until the reflectance signal saturated to near zero or one solar absorptivity. See Figure 43 for the set-up of the system. All sources of external lighting in the test area were eliminated, including turning off any lights in the test room and masking off any cracks or windows where light could penetrate. A black drape was then placed over the measurement system to reassure that no exterior light other than the source light was getting to the sphere or measurement aperture.

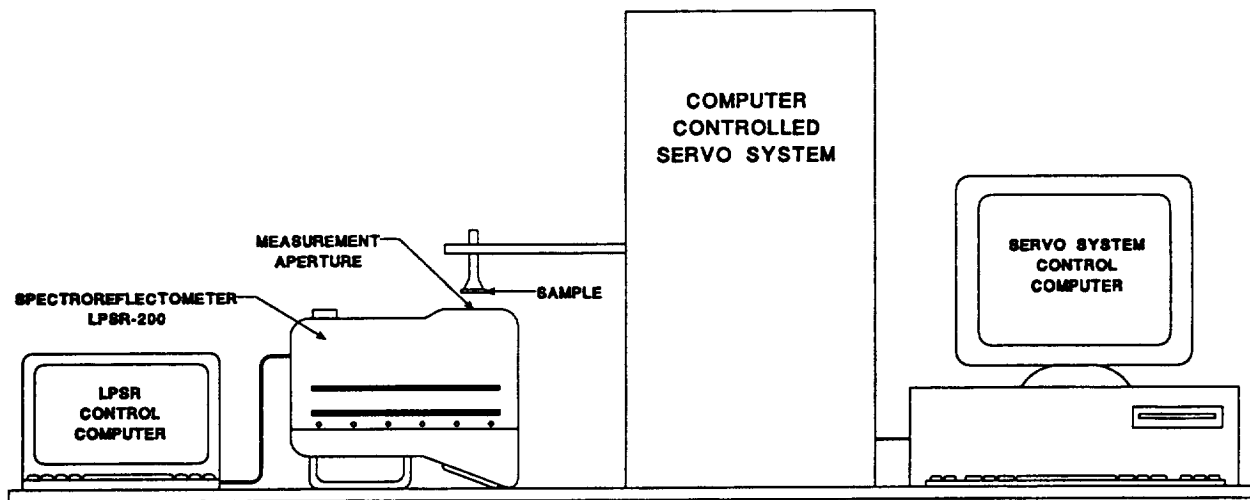

Figure 38. LPSR Distance Study Set-Up

Before beginning the tests, we characterized the beam coming from the LPSR at different distances. It was determined that the beam tends to move away from the sample center as sample distance increases from the aperture. This concurs with the fact that the beam is entering the sphere off the perpendicular axis. This was important to the test because we needed to make sure that the light source was still hitting the sample when the sample was 40 millimeters from the measurement aperture. The graphical results from the study of the beam profile can be found in the Appendix.

3.2 LPSR Sample Standoff Study Results

The results of these tests confirmed the anticipated conclusion. The specular surfaces, such as the gold and Mg-F₂ mirrors, tended to behave similar to a hyperbolic function for the specular surfaces. Whereas the diffuse surfaces, such as the S13G/LO white paint, behaved similar to a logarithmic function. This can be contributed to the way light is reflected off the different types of surfaces. On a true Lambertian diffuse surface, light reflects with equal brightness in all viewing angles. Thus as the sample distance increases from the measurement aperture, the light reaching the detector decreases almost linearly from 0 to ten millimeters. The one limiting factor of the system is that because the incident beam is 15 degrees off the perpendicular axis the beam begins to miss the sample. This in turn decreases the amount of light reflected back into the integrating sphere. See Figure 39 below.

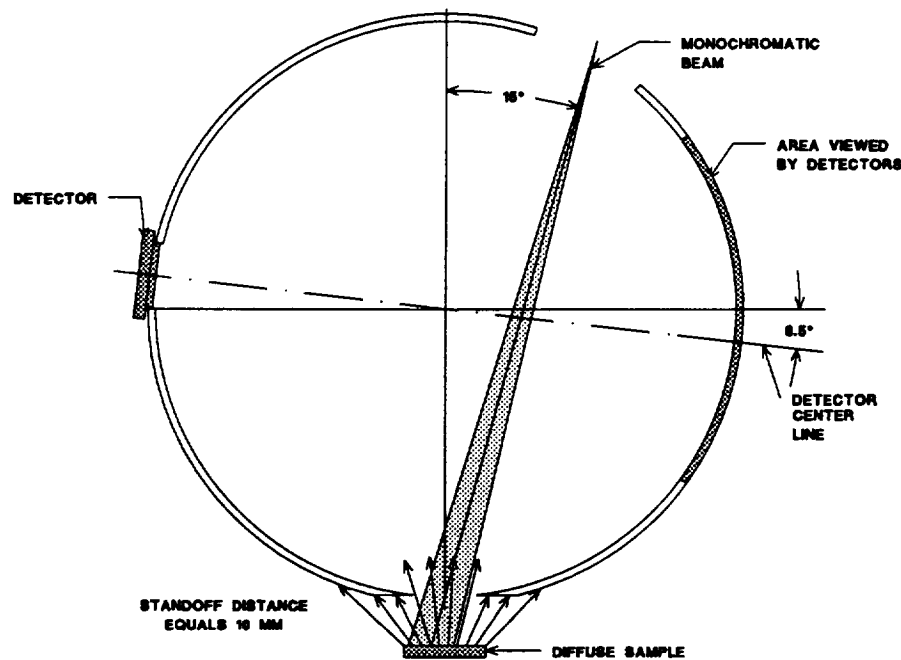

Figure 39. Ray diagram using a diffuse sample 10 mm from the integration sphere.

In contrast, with a specular surface the incident angle equals the reflected angle. Therefore, there would be minor changes in the solar absorptivity until the sample reaches a height when most of the reflected light never enters the integration sphere. As the distance increases, we see the same effect that we saw with the diffuse surface. Eventually all of the incident beam misses the sample surface, therefore eliminating the reflected light inside the sphere. See Figure 40.

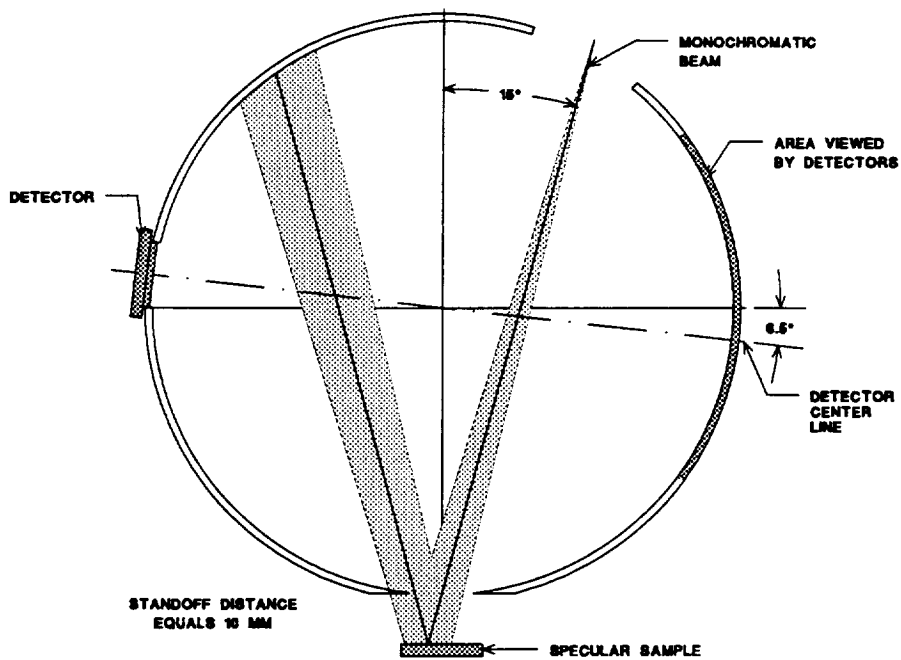

Figure 40. Ray diagram using a specular sample 10 mm from the integrating sphere.

The spectral reflectance and solar absorptivity graphs for the various surfaces studied with the LPSR can be found in Figures 41 - 47 on the following seven pages.

SOLAR ABSORPTIVITY VS STANDOFF FOR VARIOUS SURFACE MATERIALS

STANDOFF DISTANCE FROM 0 TO 40 MM - LPSR DATA

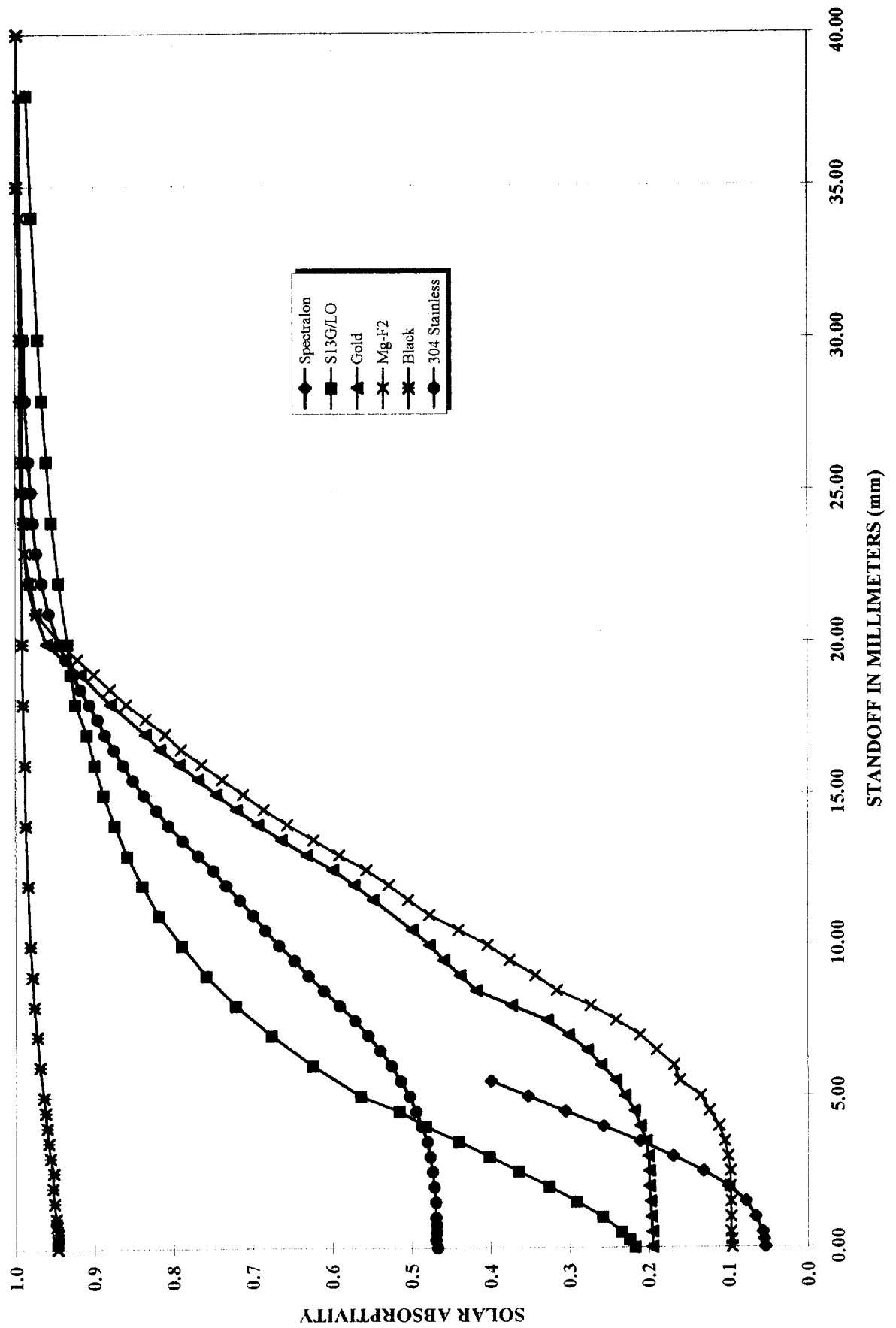

Figure 41. Solar Absorptivity Verses Standoff for Various Surface Materials

SPECTRAL REFLECTANCE VS STANDOFF FOR SPECTRALON

STANDOFF DISTANCE FROM -2.50 MM TO 5.25 MM - LPSR DATA

THIS GRAPHICAL DATA IS AN ABBREVIATED VERSION. ACTUAL SCANS WERE TAKEN EVERY 0.25 MM.

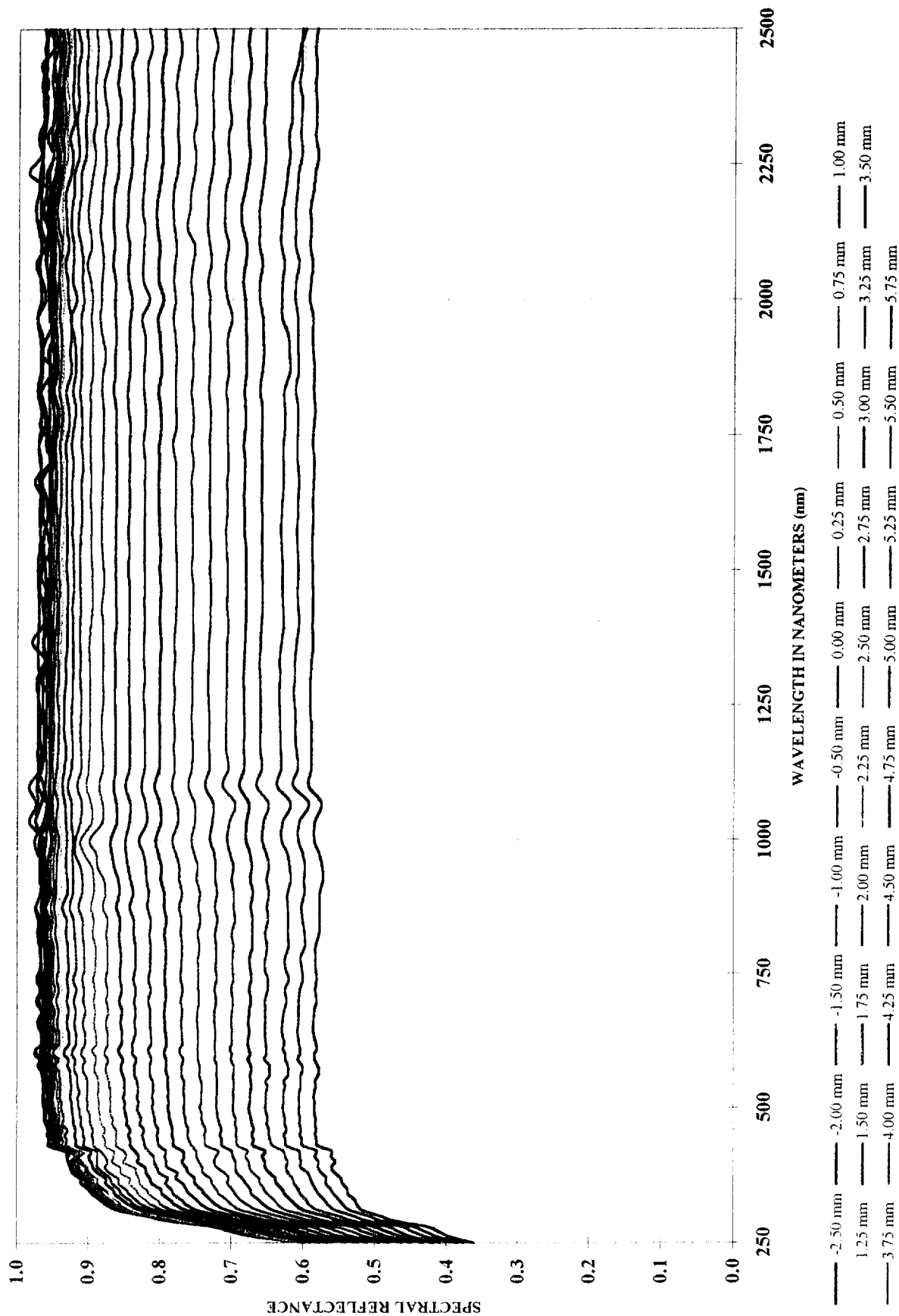

Figure 42. Spectral Reflectance Verses Standoff for Spectralon

SPECTRAL REFLECTANCE VS STANDOFF FOR S13G/LO WHITE DIFFUSE PAINT

STANDOFF DISTANCE FROM 0 TO 70 MM - LPSR DATA

THIS GRAPHICAL DATA IS AN ABBREVIATED VERSION. ACTUAL SCANS WERE TAKEN EVERY 0.5 MM.

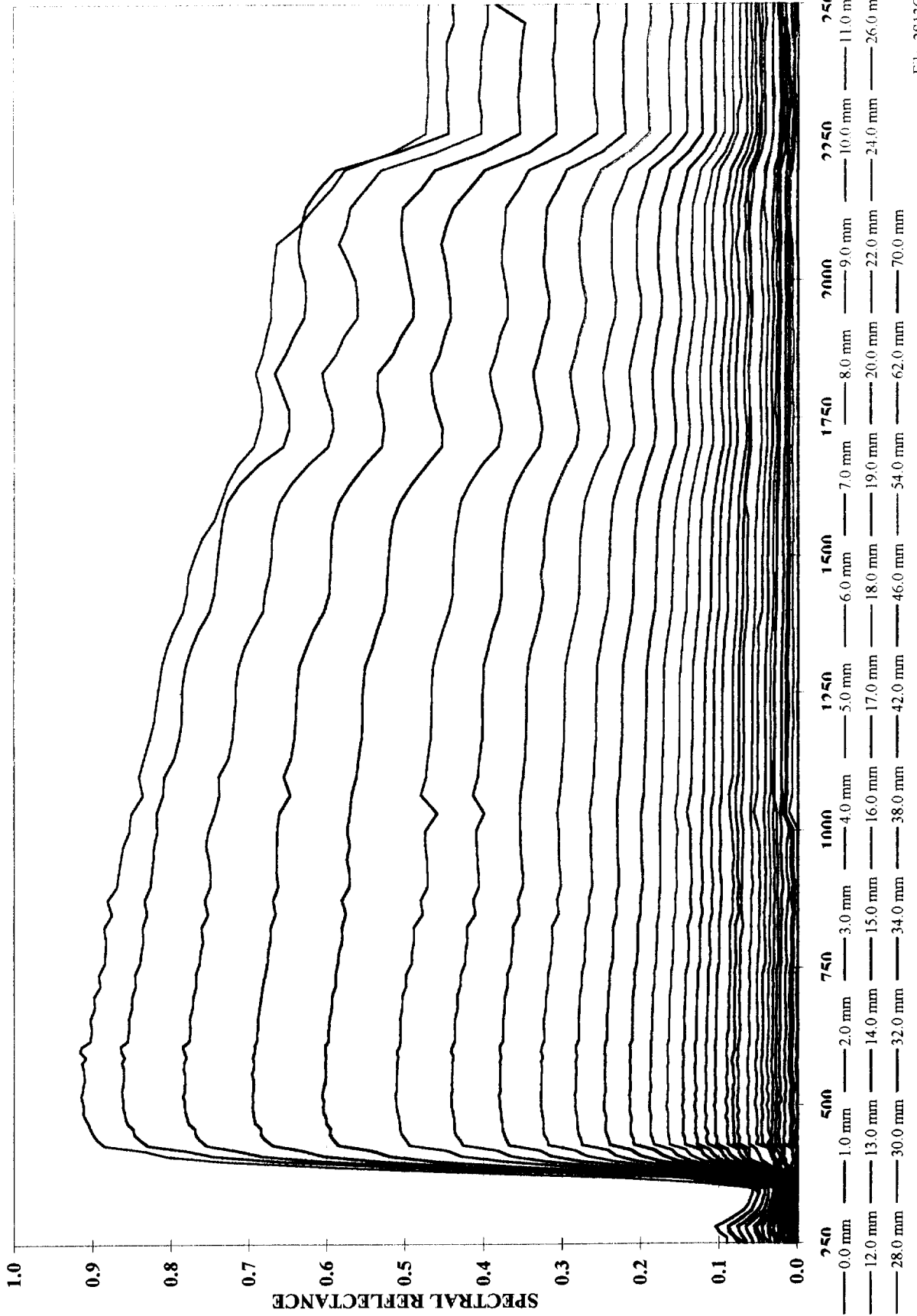

Figure 43. Spectral Reflectance Verses Standoff for S13G/LO White Diffuse Paint

SPECTRAL REFLECTANCE VS STANDOFF FOR GOLD

STANDOFF DISTANCE FROM 0 TO 30 MM - LPSR DATA

THIS GRAPHICAL DATA IS AN ABBREVIATED VERSION. ACTUAL SCANS WERE TAKEN EVERY 0.25 MM.

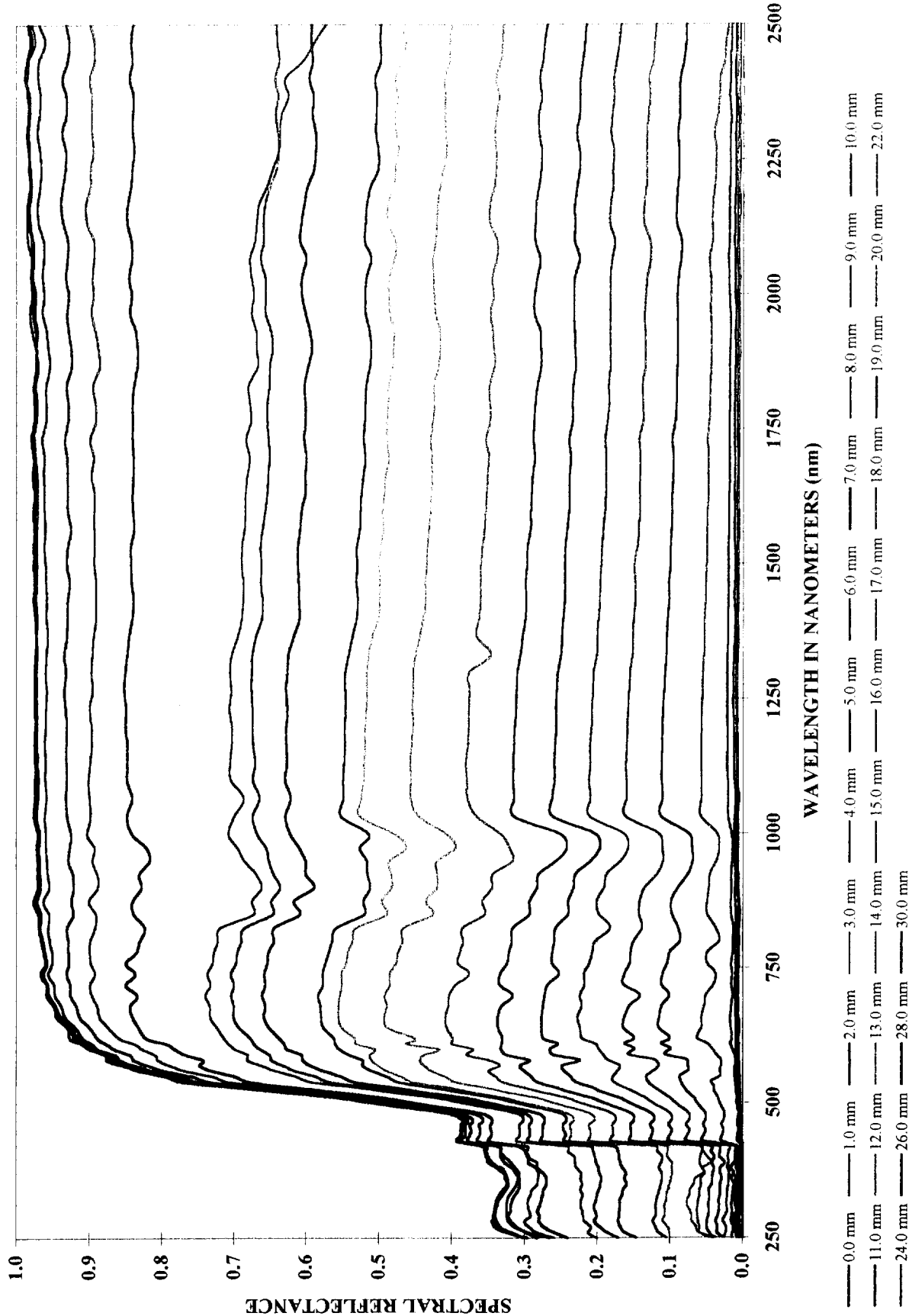

Figure 44. Spectral Reflectance Verses Standoff for Gold

SPECTRAL REFLECTANCE VS STANDOFF DISTANCE FOR MgF₂ OPTICAL WITNESS SAMPLE

STANDOFF DISTANCE FROM 0 TO 38 MM - LPSR DATA

THIS GRAPHICAL DATA IS AN ABBREVIATED VERSION. ACTUAL SCANS WERE TAKEN EVERY 0.25 MM.

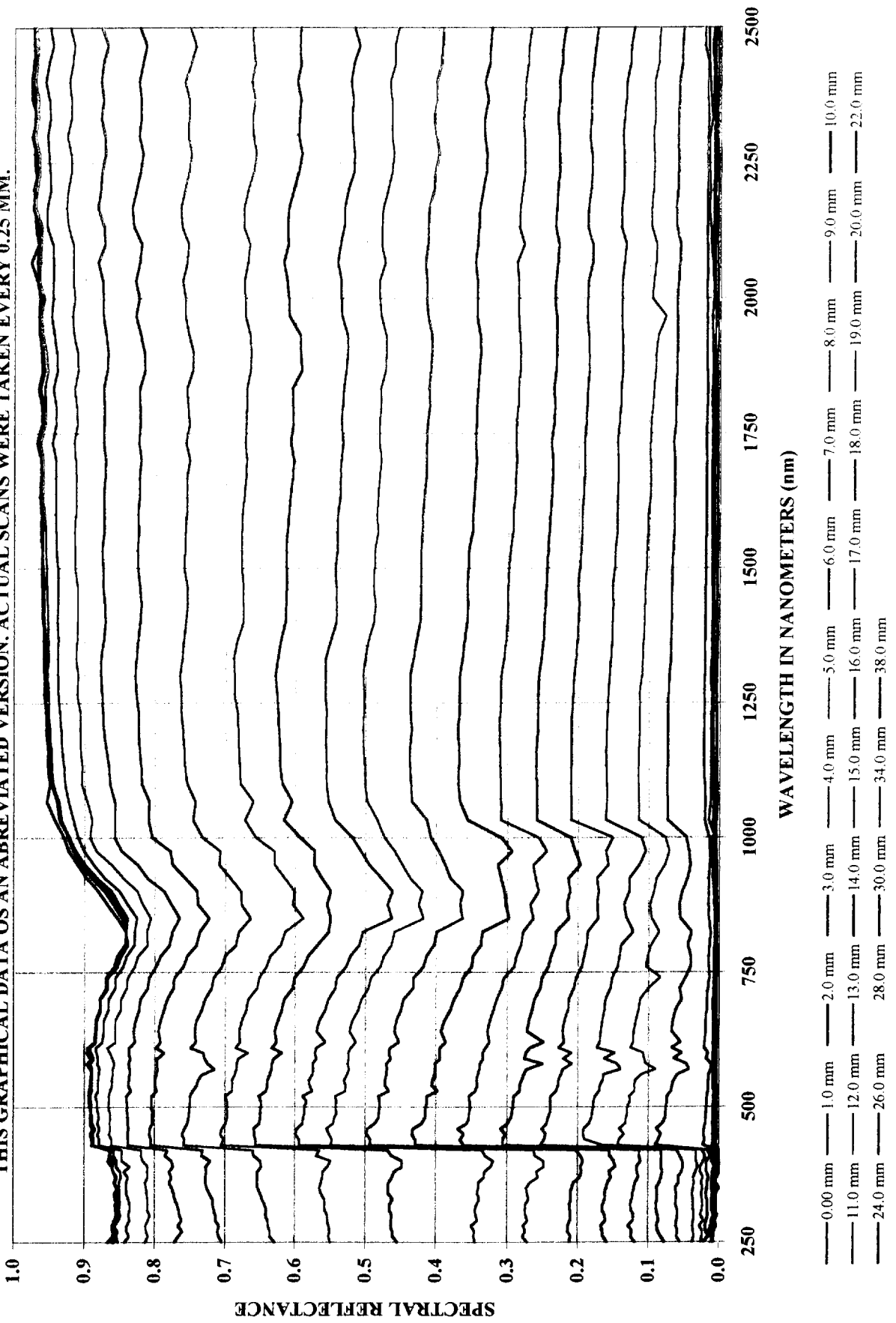

Figure 45. Spectral Reflectance Verses Standoff for an Optical Witness Sample

SPECTRAL REFLECTANCE VS STANDOFF FOR 304 STAINLESS STEEL

STANDOFF DISTANCE FROM 0 TO 40 MM - LPSR DATA

THIS GRAPHICAL DATA IS AN ABBREVIATED VERSION. ACTUAL SCANS WERE TAKEN EVERY 0.25 MM.

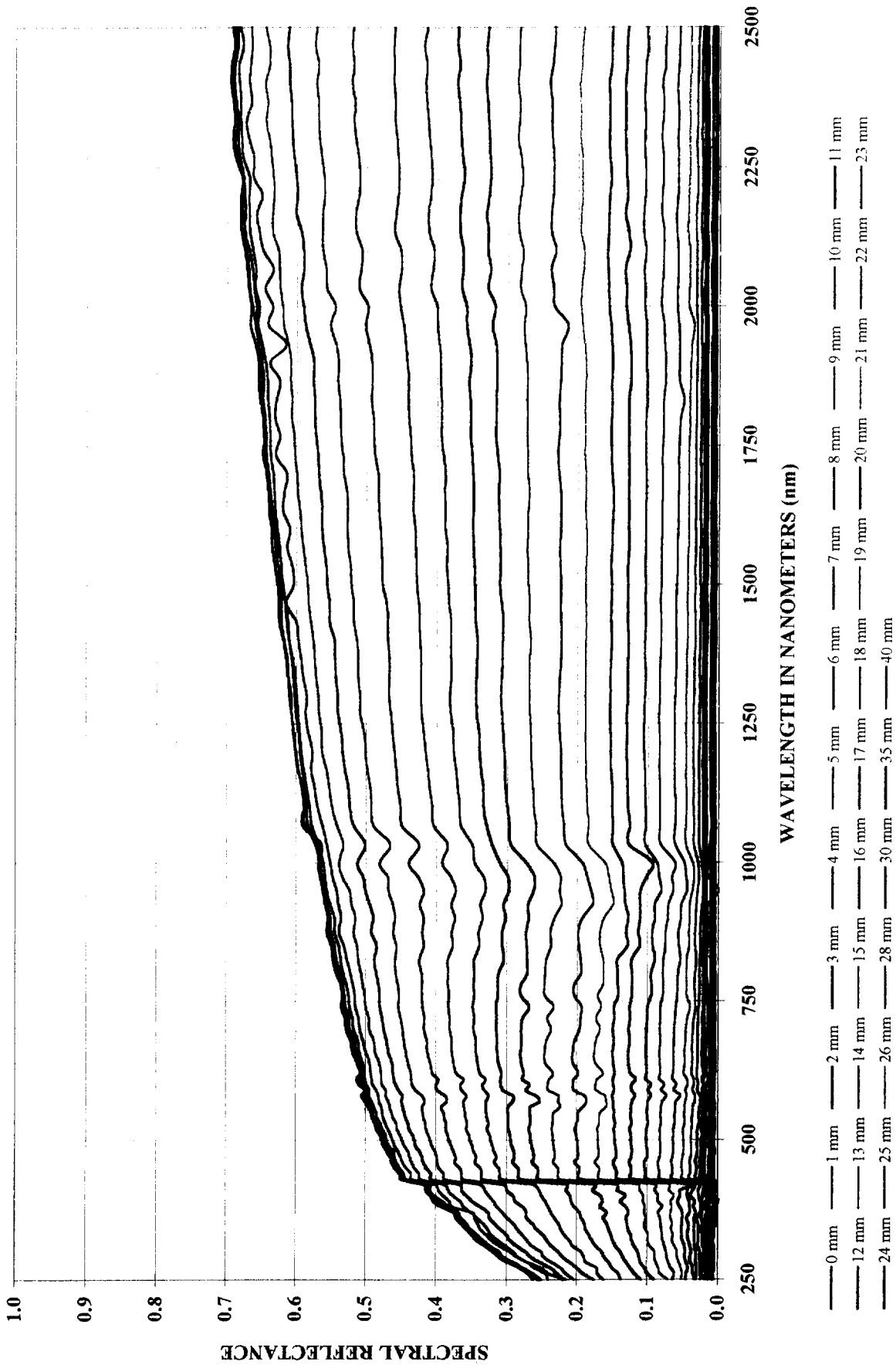

Figure 46. Spectral Reflectance Verses Standoff for 304 Stainless Steel

SPECTRAL REFLECTANCE VS STANDOFF FOR BLACK PAINT
STANDOFF DISTANCE FROM 0 TO 40 MM. REFLECTANCE SCALE FROM 0 TO 0.1 - LPSR DATA
THIS GRAPHICAL DATA IS AN ABBREVIATED VERSION. ACTUAL SCANS WERE TAKEN EVERY 0.25 MM.

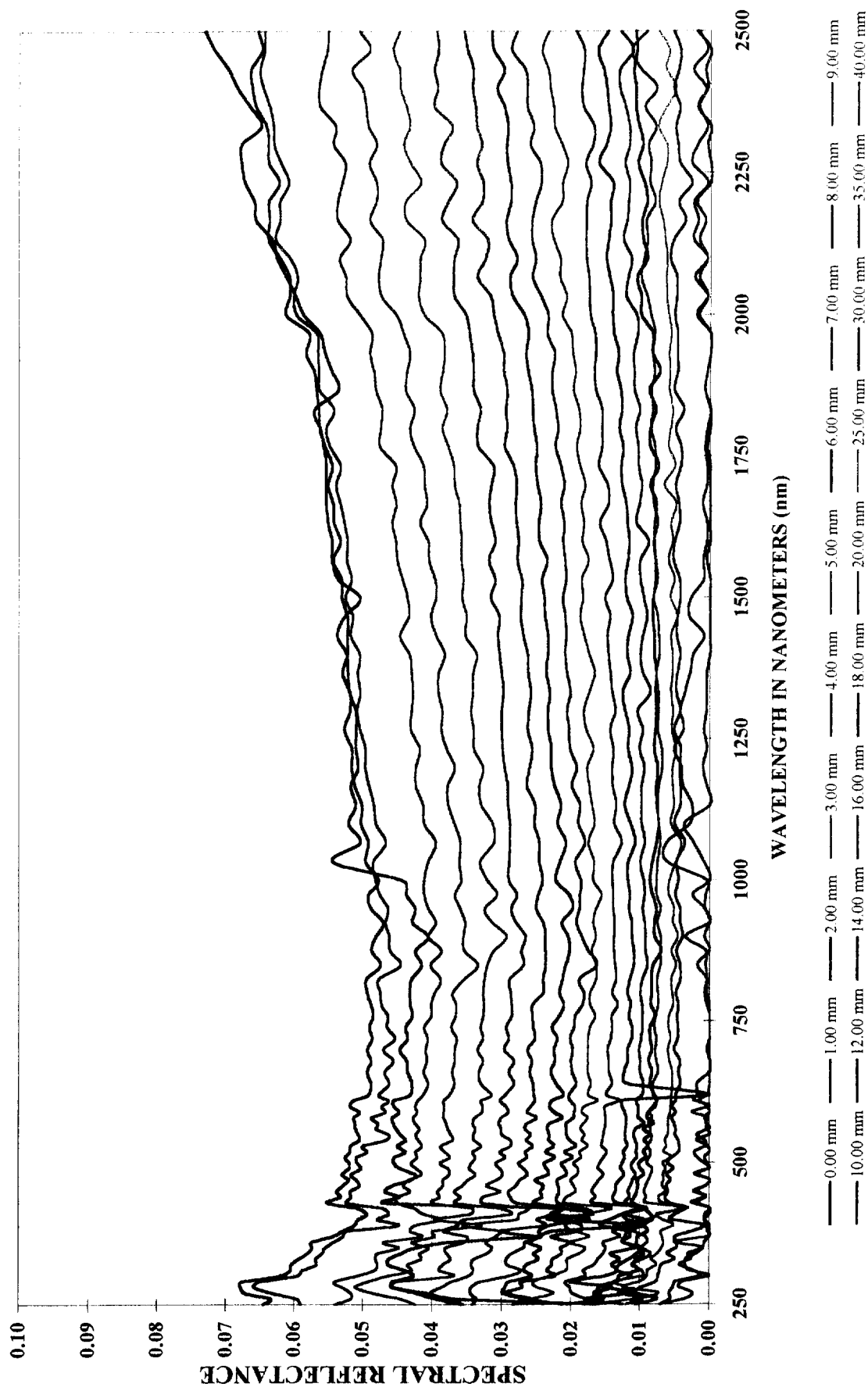

Figure 47. Spectral Reflectance Verses Standoff for Black Paint.

4.0 CONCLUSIONS

A number of accomplishments have been achieved in this work, including the determination of a cleaning method to insure a contamination free system. Also, in the long term UV exposure study changes occurred in the 2219 aluminum samples, chromic anodized aluminum and Z-93 white diffuse paint. In analyzing all three of the optical witness samples, those protected and not protected with a window, no significant changes occurred in the spectral reflectance. The 2219 aluminum proved to be a different case. The spectral reflectance in the two test samples improved slightly in both the ultra-violet and infrared region. This could be attributed to cleaning the surface of the aluminum while it was in the UV chamber.

More drastic changes occurred in the Z-93 white diffuse paint. Sample #B169-7 which was protected with a Pyrex window had the most significant spectral reflectance increase in the ultra-violet region but had no change in the visible and infrared area. Sample #B169-13, which was protected with a quartz window, and sample #B169-3, which had no protection window, had smaller spectral reflectance improvements in the ultra-violet region but decreases occurred in the visible region. The chromic anodized aluminum behaved in a different manner than the other materials. There was no protection on the sample for the test therefore there are no comparisons between with or without the window. In all three scans on various areas of the sample definite changes were found in the spectral reflectance thought the scan. In the ultra-violet region, the reflectance increased in several wavelength regions but it also decreased in the other areas.

Overall in the ultra-violet area there was neither an increase nor a decrease. In the infrared region, the spectral reflectance curve was flattened or straightened significantly after exposure. LPSR scans were performed on the windows to monitor any possible changes in their spectral reflectance due to changes in the material or possibly even particles that have deposited on the surface from the samples. Upon analyzing the data from the Pyrex window #1, which protected optical witness sample #3, improvements occurred in the ultra-violet region while decreases of the spectral reflectance occurred in the infrared area. This decrease in the infrared region was also found in Pyrex window #2 which protected the Z-93 paint but the Pyrex window #2 only had a slight increase in the ultra-violet region. This decrease could be attributed to the degradation of the material in the infrared region seeing how this behavior was found in both windows. No changes occurred in the quartz window #1 which protected optical witness sample #4 but quartz window #2 which protected the Z-93 paint showed a decrease in reflectance in the infrared and part of the visible regions. This decrease could be attributed to possible particles from the Z-93 paint being deposited on the surface. Further study of this subject will have to be conducted in order to determine the true cause of the decrease. No changes were found in the control specimen except for the fused silica window #3 which decreased in magnitude over the entire scan.

The distance between the measurement aperture and the sample has proven to be an area of concern when measuring specula and diffuse sample. The experimenter needs to be aware that the incident beam is entering the sphere off the perpendicular angle thus causing loss of light as distances between the aperture and sample increases.

Appendix

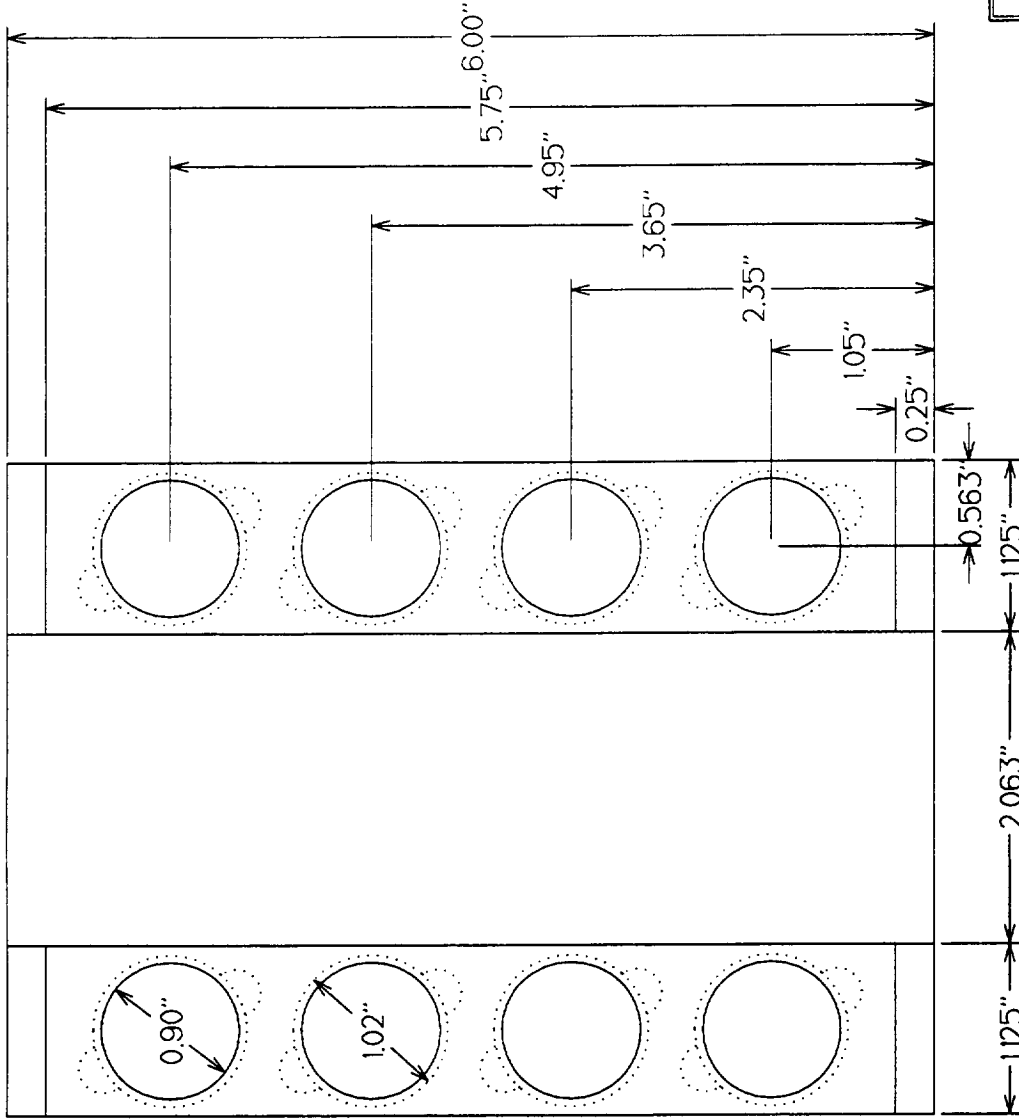

FRONT VIEW

U.A.H. CENTER FOR AUTOMATION AND ROBOTICS	
UV Vacuum Modified Sample Plate	
QUANTITY: 1	DATE: November 9, 1994
MATERIAL: Aluminum	DRAWING: UVVS-101P
TOLERANCE: +/- 0.010"	DRAWN BY: S. O'Brien
SCALE: 125	ACCOUNT: 6-33602

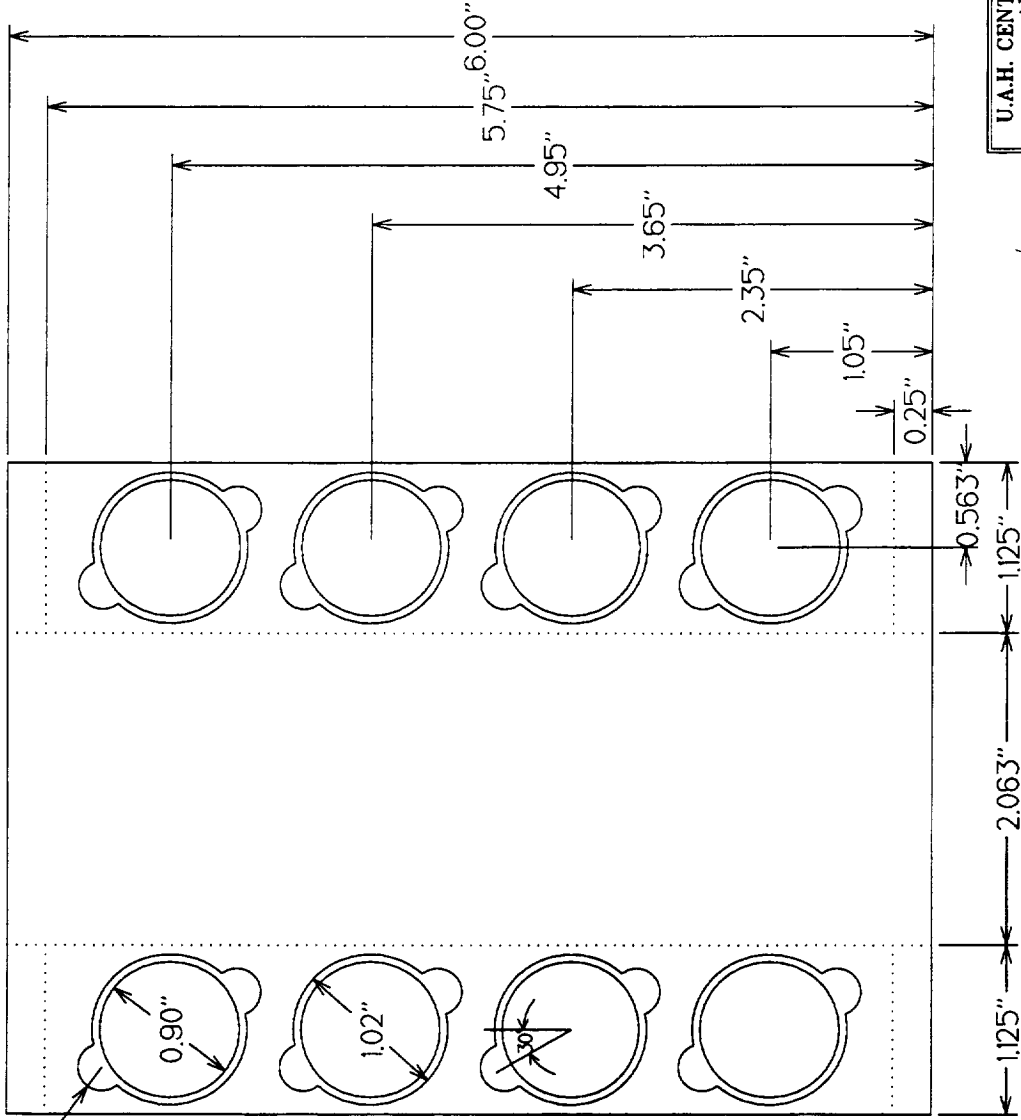

0.156" TYP.
16 PLACES
0.45" DEEP

BACK VIEW

U.A.H. CENTER FOR AUTOMATION AND ROBOTICS	
UV Vacuum Modified Sample Plate	
QUANTITY: 1	DATE: November 9, 1994
MATERIAL: 1/2" 6061 T6 Aluminum	DRAWING: UVVS-101B
TOLERANCE: +/- 0.010"	DRAWN BY: S. O'Brien
SCALE: 1:1.25	ACCOUNT: 6-33502

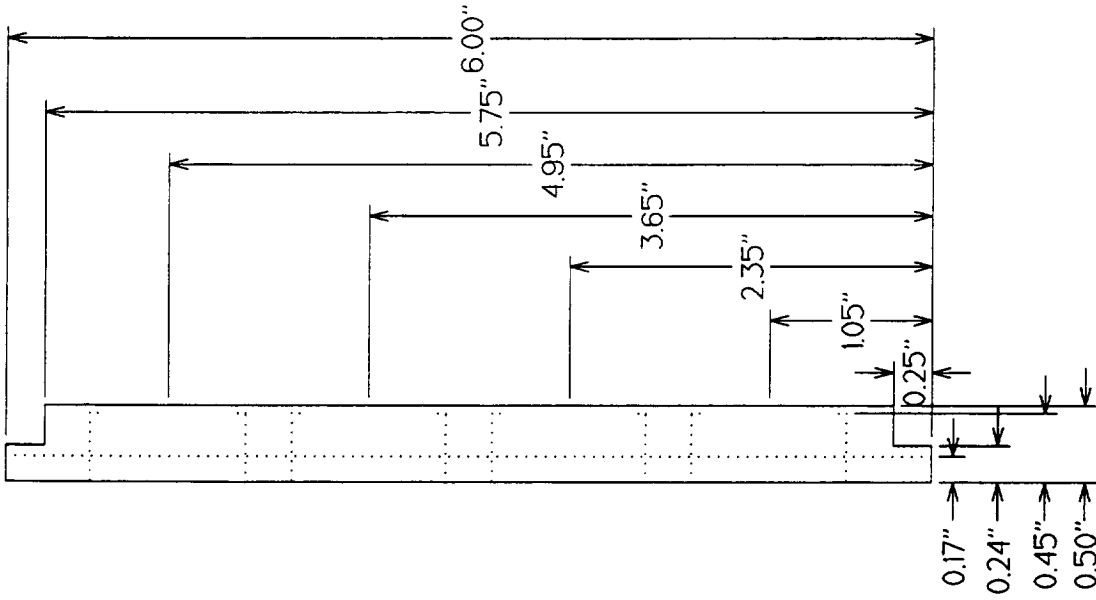

SIDE VIEW

U.A.H. CENTER FOR AUTOMATION AND ROBOTICS	
UV Vacuum Modified Sample Plate	
QUANTITY: 1	DATE: November 10, 1994
MATERIAL: 1/2" 6061 T6 Aluminum	DRAWING: UVYS-101S
TOLERANCE: +/- 0.010"	DRAWN BY: S. O'Brien
SCALE: 1:1.25	ACCOUNT: 6-33502

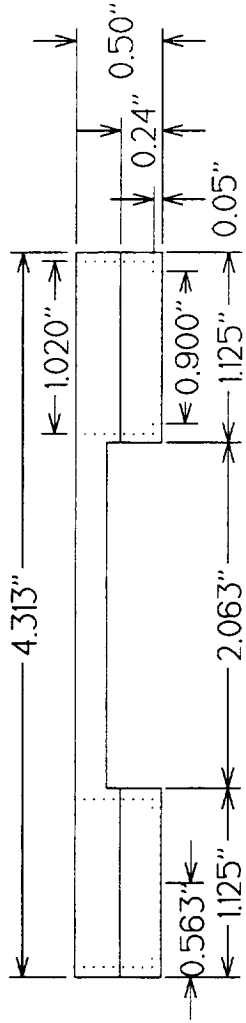

TOP VIEW

U.A.H. CENTER FOR AUTOMATION AND ROBOTICS	
UV Vacuum Modified Sample Plate	
QUANTITY: 1	DATE: November 9, 1994
MATERIAL: 1/2" 6061 T6 Aluminum	DRAWING: UVVS-101T
TOLERANCE: +/- 0.010"	DRAWN BY: S. O'Brien
SCALE: 1:1.125	ACCOUNT: 6-33502

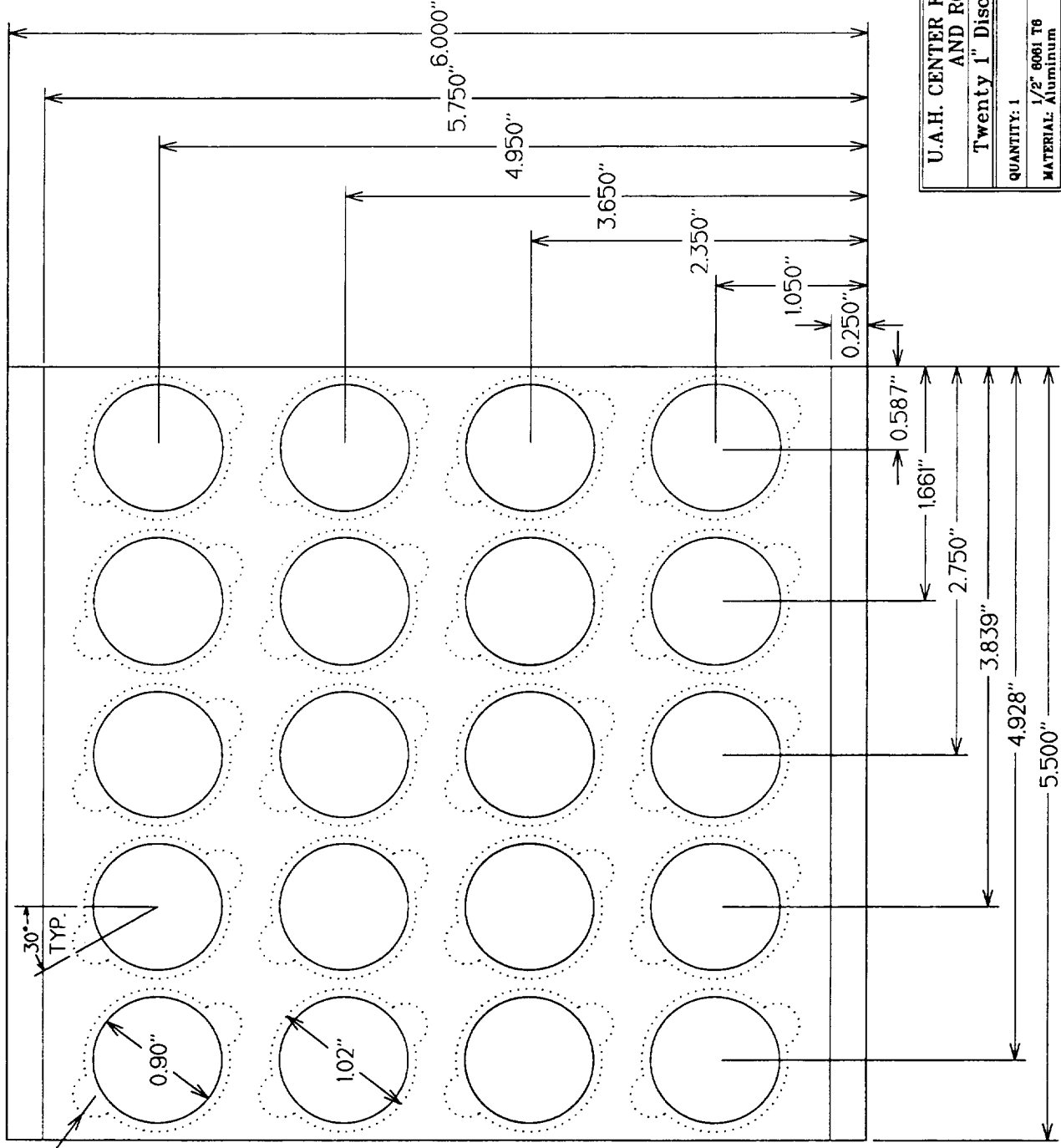

FRONT VIEW

U.A.H. CENTER FOR AUTOMATION AND ROBOTICS	
Twenty 1" Disc Sample Holder	
QUANTITY: 1	DATE: December 5, 1984
MATERIAL: 1/2" 6061 T6 Aluminum	DRAWING: UVVS-201F
TOLERANCE: +/- 0.010"	DRAWN BY: S. O'Brien
SCALE: 1:1.125	ACCOUNT: 6-33502

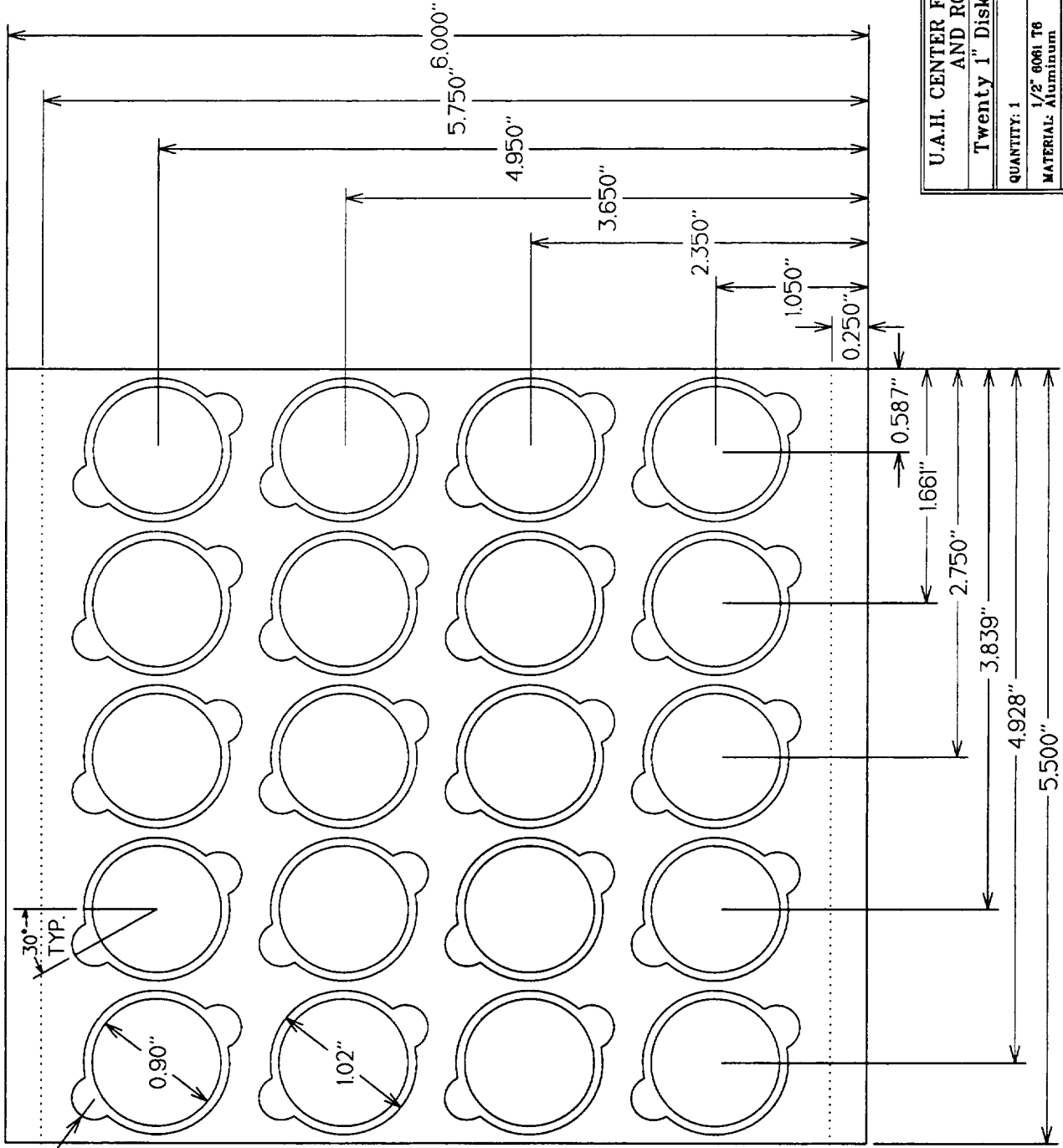

0.156" TYP.
16 PLACES
0.45" DEEP

U.A.H. CENTER FOR AUTOMATION AND ROBOTICS	
Twenty 1" Disk Sample Holder	
QUANTITY: 1	DATE: December 5, 1994
MATERIAL: 1/2" 6061 T6 Aluminum	DRAWING: UVVS-201B
TOLERANCE +/- 0.010"	DRAWN BY: S. O'Brien
SCALE: 1:1.125	ACCOUNT: 6-33502

BACK VIEW

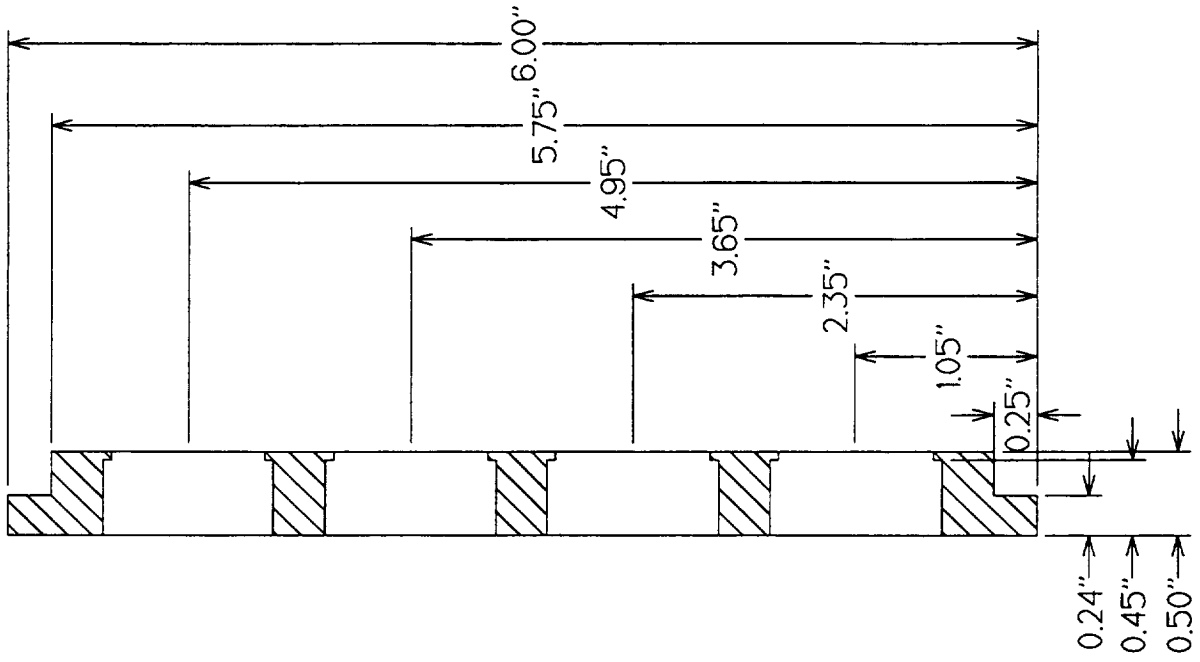

CROSS SECTIONAL SIDE VIEW

U.A.H. CENTER FOR AUTOMATION AND ROBOTICS	
Twenty 1" Disc Sample Holder	
QUANTITY: 1	DATE: December 5, 1994
MATERIAL: 6061 T6 Aluminum	DRAWING: UVVS-201S
TOLERANCE: +/- 0.010"	DRAWN BY: S. O'Brien
SCALE: 1:1.125	ACCOUNT: 5-33502

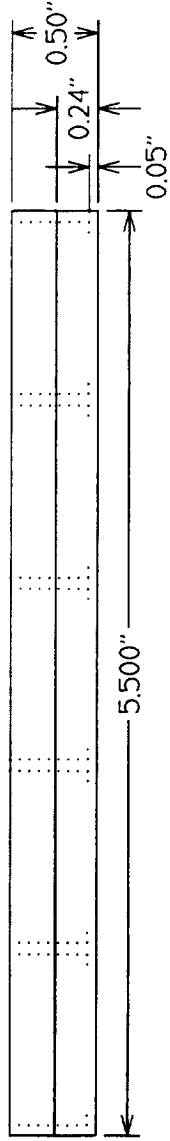

TOP VIEW

U.A.H. CENTER FOR AUTOMATION AND ROBOTICS	
Twenty 1" Disc Sample Holder	
QUANTITY: 1	DATE: December 5, 1984
1/2" 6061 T6 MATERIAL: Aluminum	DRAWING: UVYS-201T
TOLERANCE: +/- 0.010"	DRAWN BY: S. O'Brien
SCALE: 1:125	ACCOUNT: 5-33502

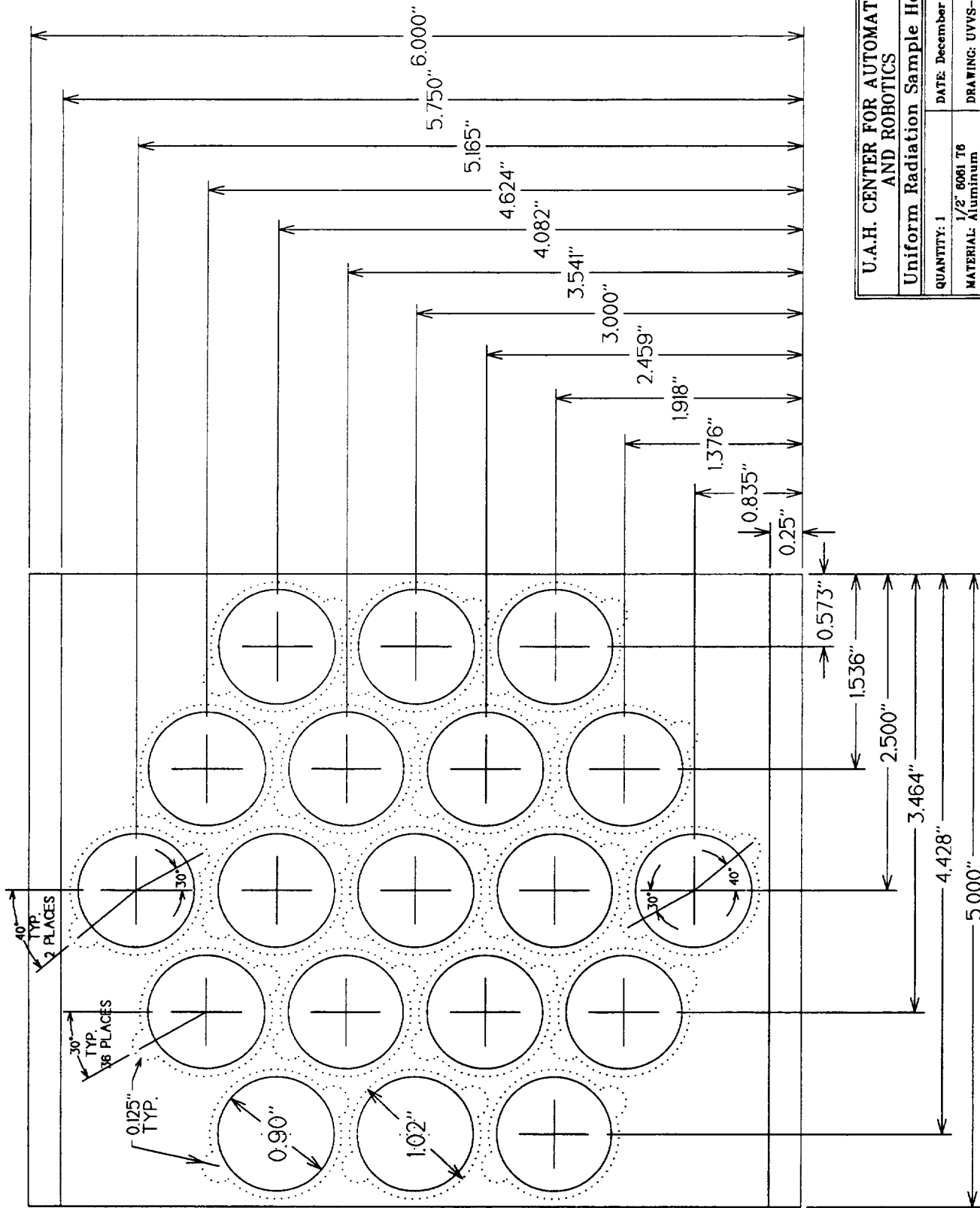

U.A.H. CENTER FOR AUTOMATION AND ROBOTICS	
Uniform Radiation Sample Holder	
QUANTITY: 1	DATE: December 5, 1994
MATERIAL: 6061 T6 Aluminum	DRAWING: UVVS-202F
TOLERANCE: +/- 0.010"	DRAWN BY: S. O'Brien
SCALE: 1:1.125	ACCOUNT: 5-33502

FRONT VIEW

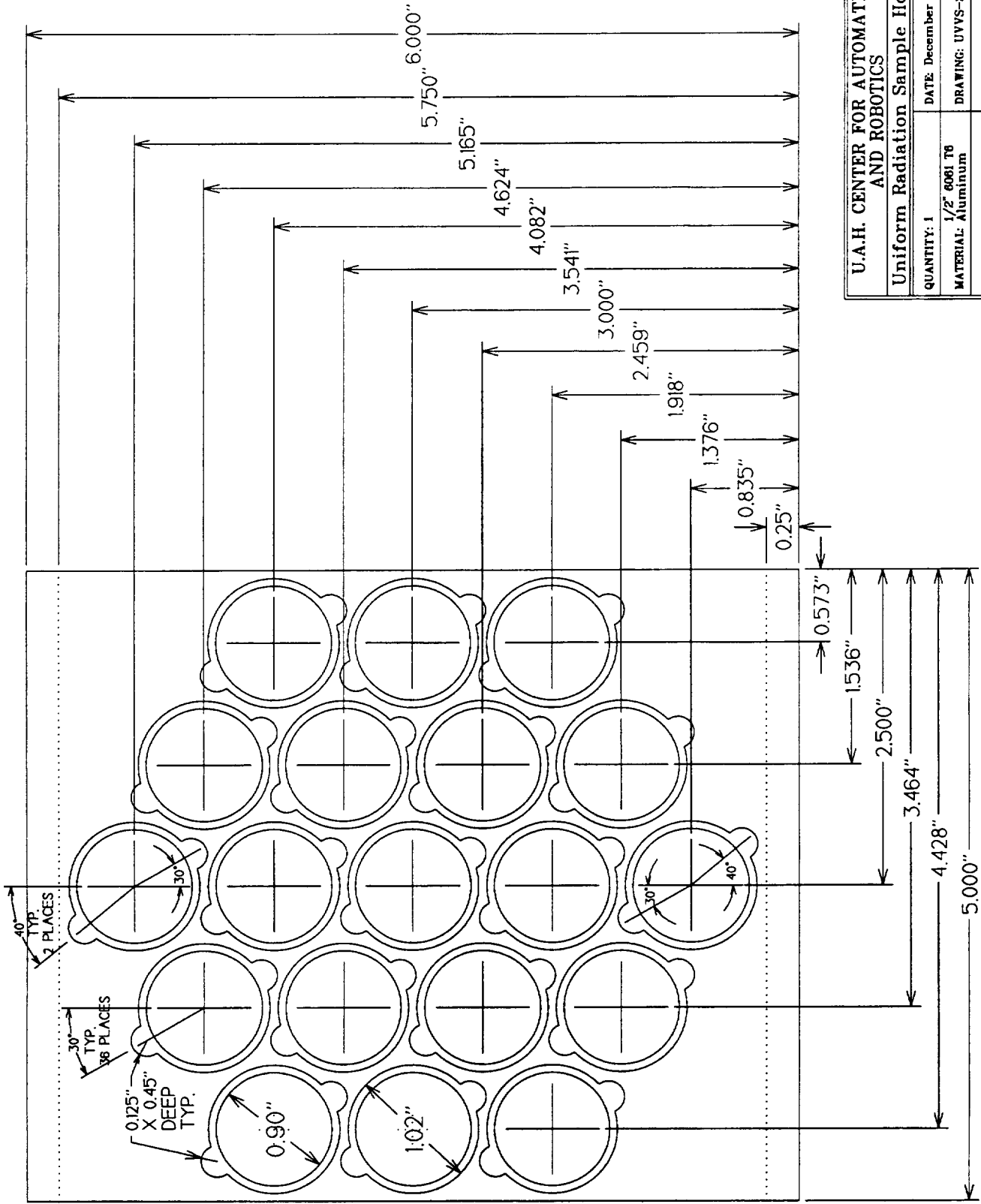

BACK VIEW

U.A.H. CENTER FOR AUTOMATION AND ROBOTICS	
Uniform Radiation Sample Holder	
QUANTITY: 1	DATE: December 5, 1984
MATERIAL: 1/2" 6061 T6 Aluminum	DRAWING: UVVS-202B
TOLERANCE: +/- 0.010"	DRAWN BY: S. O'Brien
SCALE: 1:1.125	ACCOUNT: 6-33502

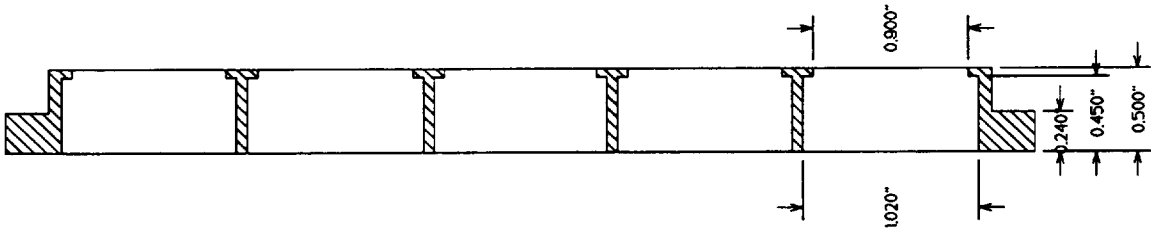

A

**CROSS SECTIONAL
VIEW OF THE SIDE**

U.A.H. CENTER FOR AUTOMATION AND ROBOTICS	
Uniform Radiation Sample Holder	
QUANTITY: 1	DATE: December 5, 1994
MATERIAL: 1/2" 6061 T6 Aluminum	DRAWING: UVVS-202S
TOLERANCE: +/- 0.010"	DRAWN BY: S. O'Brien
SCALE: 1:1.125	ACCOUNT: 5-38602

