

THE SUPERCONDUCTING MHD-PROPELLED SHIP YAMATO-1

YOHEI SASAKAWA, Chairman, YAMATO Project Committee,
Ship & Ocean Foundation
SETSUO TAKEZAWA, Ship & Ocean Foundation
YOSHINORI SUGAWARA, Ship & Ocean Foundation
YOSHIHIRO KYOTANI, Ship & Ocean Foundation



YAMATO-1 running in the harbor of Kobe

1. Introduction

In 1985 the Ship & Ocean Foundation (SOF) created a committee under the chairmanship of Mr. Yohei Sasakawa, Former President of the Ship & Ocean Foundation, and began researches into superconducting magnetohydrodynamic (MHD) ship propulsion. In 1989 SOF set to construction of a experimental ship on the basis of theoretical and experimental researches pursued until then. The experimental ship named YAMATO-1 became the world's first superconducting MHD-propelled ship on her trial runs in June 1992.

This paper describes the outline of the YAMATO-1 and sea trial test results.

2. The YAMATO-1 project

In the first year of the project (1985), we gathered information on superconducting magnets and cryogenic technology to gain a clear picture of superconductivity applications, and worked out an action plan. Model ship thrusters were designed to incorporate saddle-shaped superconducting coils made of NbTi wire. In 1986 the best people from industry joined us to work on this project. At the Tsukuba Institute, researchers performed tests and experiments by use of model thrusters having the basic structure shown in Fig. 1, to look into MHD thruster's performance and characteristics as a hydraulic device, and pressure increase of seawater in the thruster ducts; propulsion characteristics and the interaction between the hull and thrusters were examined by using model ships.

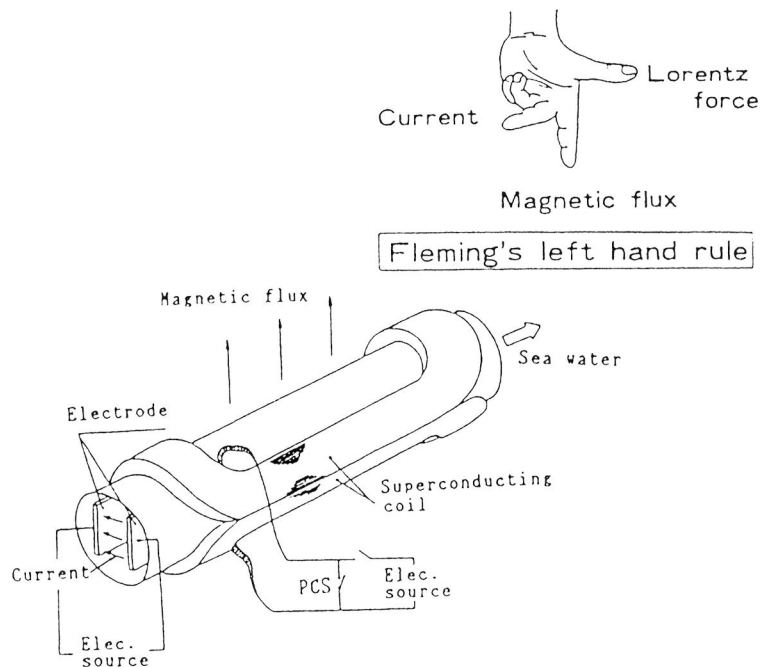

Fig.1 Principle and Basic structure of MHD thruster

In 1988 the experimental ship thruster was designed according to the particulars shown in Table 1 so as to have a shielding-free structure which can minimize magnetic leakage by accommodating six superconducting coil units in a single cryostat (Fig. 2). Construction of a experimental ship featuring a streamlined hullform (Fig. 3) began in the wake of the manufacture of twin thrusters, and the experimental ship YAMATO-1 was completed at the end of 1991. Table 2 summarizes the YAMATO-1 project in chronological order. Photo 1 is the YAMATO-1 under fitting work.

Table 1 Basic particulars of the MHD thruster

Compound magnetic flux density at center	4 Tesla
Electrode current(normal)	2,000 A
Lorentz force	8,000 N/set
Thrust	4,000 N/set
Weight	18 Ton/set

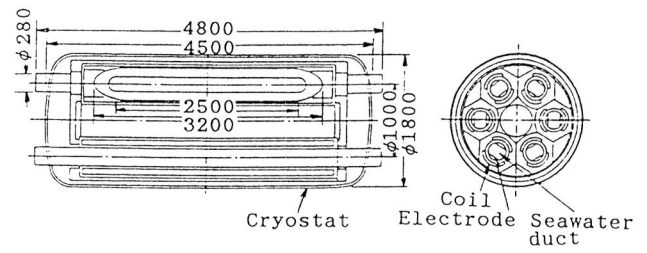

Fig.2 Basic structure of MHD thruster

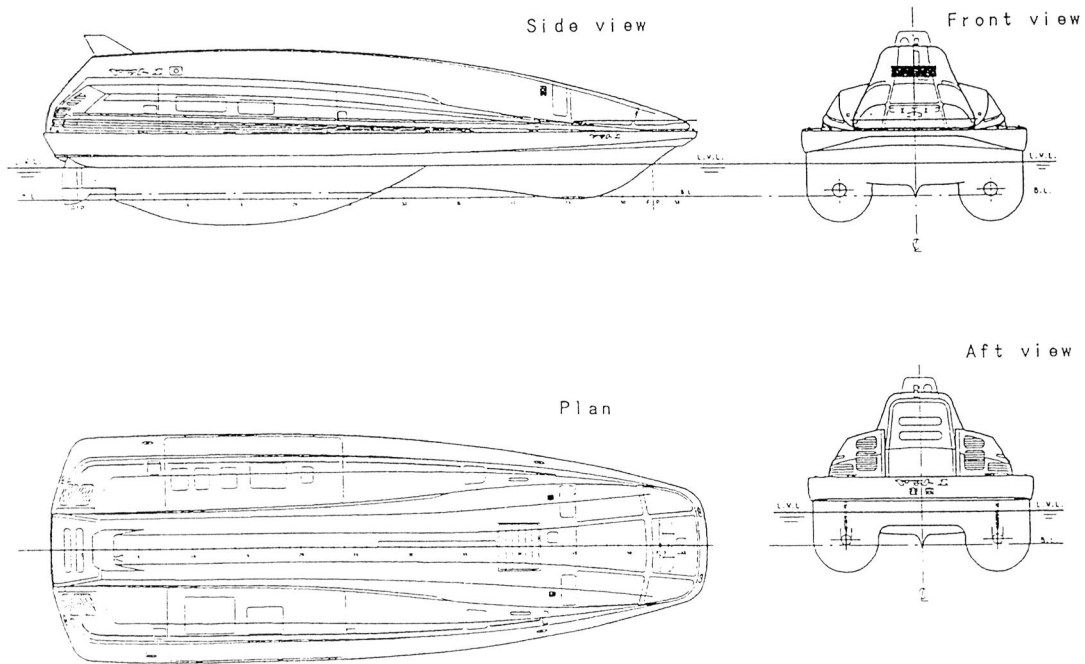

Fig.3 Hull form for YAMATO-1

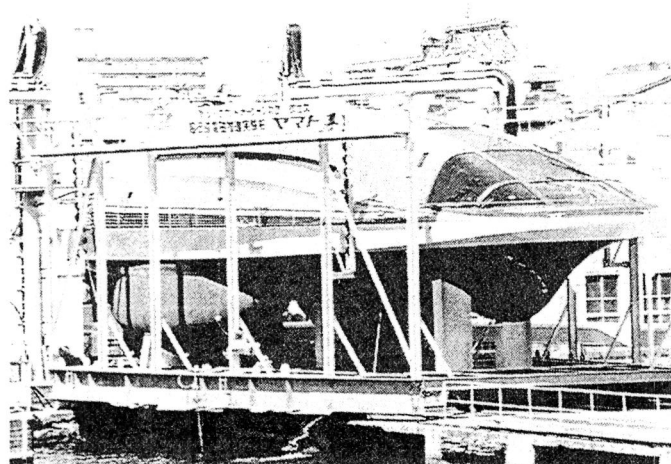

Photo 1 YAMATO-1 under outfitting work

Table 2 The YAMATO-1 project

1985	<ul style="list-style-type: none"> •Study on the present state of cryogenenic technology •Researches into MHD thrusters to work out the basic plan 	Researches and experiments
1986	<ul style="list-style-type: none"> •Researches into hull forms and MHD propulsion systems •Manufacture of superconducting MHD thruster for experimetal purposes 	
1987	<ul style="list-style-type: none"> •Self-Propulsion experiments by use of an internal magnetic field type model ship •Manufacture of a large-sized superconducting MHD thruster and characteristic tests •Designning of superconducting MHD thrusters for use in the experimental ship 	
1988	<ul style="list-style-type: none"> •Designning of the exp. ship •Manufacture of superconducting MHD thrusters for use in the experimental ship 	Designning
1989	<ul style="list-style-type: none"> •Construction of the hull of experimental ship •Assembly of superconducting MHD thrusters 	
1990	<ul style="list-style-type: none"> •Christening of YAMATO-1 •Assembly of superconducting MHD thrusters and performance tests on land 	experimental ship
1991	<ul style="list-style-type: none"> •Manufacture of ancillary equipment •Installation of the thrusters and ancillary equipment 	
1992	<ul style="list-style-type: none"> •Adjustment of inboard equipment and appararus •Sea trials and evaluation tests 	
		Manufacture and adjustment
		Trials

Table 3 Principal particlars of YAMATO-1

·Length overall	30m
·Length between perpendiculars	26.4m
·Breadth(moulded)	10.39m
·Depth(max.)	3.69m
·Draft(max.)	2.69m
·Displacement (including water in the ducts)	185ton
·Speed	abt. 8kts
(at Lorentz force 16,000N)	
·Material of the hull	Aluminium
·Number of person	10 including 3 crew

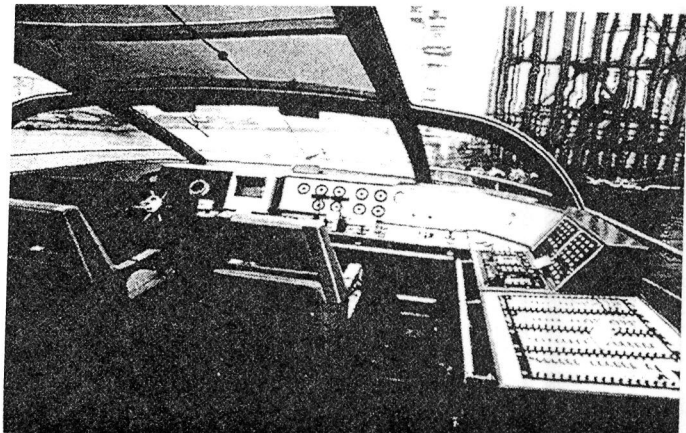

Photo 2 Wheel house equipment of YAMATO-1

3. The YAMATO-1

3-1. Hull

The unique hullform accounts for the experimental ship's remarkable sea keeping ability and course keeping ability --- a monohull having a pod on each side of the afterbody to accommodate a thruster. The ship's principal particulars and the arrangement of main equipment are shown in Table 3 and Fig. 4, respectively.

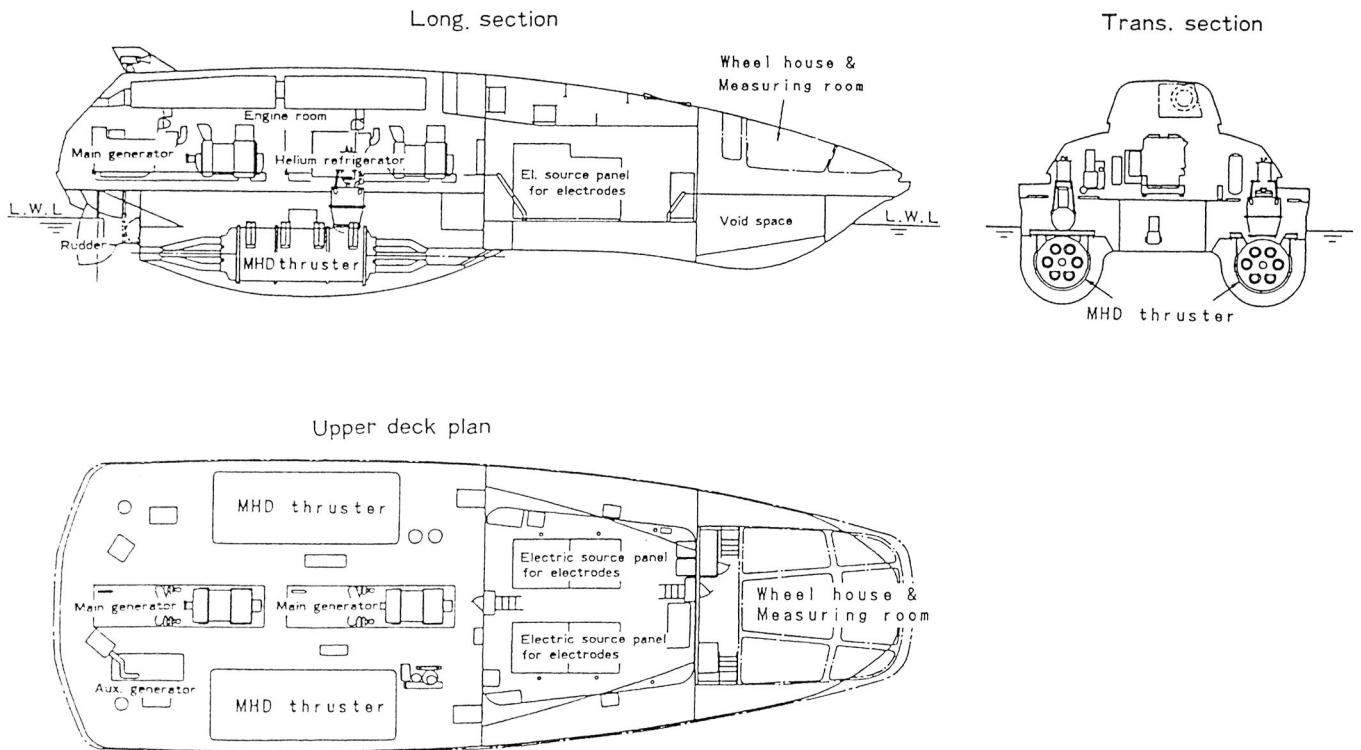

Fig.4 The general arrangement of YAMATO-1

The YAMATO-1 consists of a wheelhouse and a power-supply room and a machinery room, which are partitioned from one another by bulkheads. In the wheelhouse are steering equipment and space for ten persons including crew. Among the wheelhouse equipment are a steering console in front and a control/surveillance console on the starboard side (Photo 2). Two electrode power supply units to electrify the thrusters are housed in the power-supply room where measuring instruments are stored in racks on the port side. Main generators, two in number, are installed in the middle of the machinery room where there are an auxiliary generator and a compressor on the starboard side, whilst ancillary equipment for the main generators on the port side. The thrusters are accommodated in the pods below water line. The hull is made of anticorrosive aluminum alloy to make the ship light in weight and magnetic-resistant.

3-2. Superconducting MHD thrusters

The superconducting MHD propulsion system for use in the YAMATO-1 consists of :

- a. Superconducting MHD thrusters (superconducting coils, cryostats, electrodes, etc.)
- b. Cooling/refrigerating equipment
- c. Land-based energizing power-supply units
- d. Onboard electrode power-supply units

Refrigerators to reliquefy helium evaporated on account of heat intrusion are mounted on board, whilst a large-sized cooling equipment for initial cooling of superconducting coils is installed on shore to reduce the ship weight and to make the thrusters compact. Once energized, superconducting magnets can be used in permanent current mode; therefore, the energizing power-supply units need not be carried aboard either. Fig. 5 is the conceptual diagram of the YAMATO-1's propulsion system.

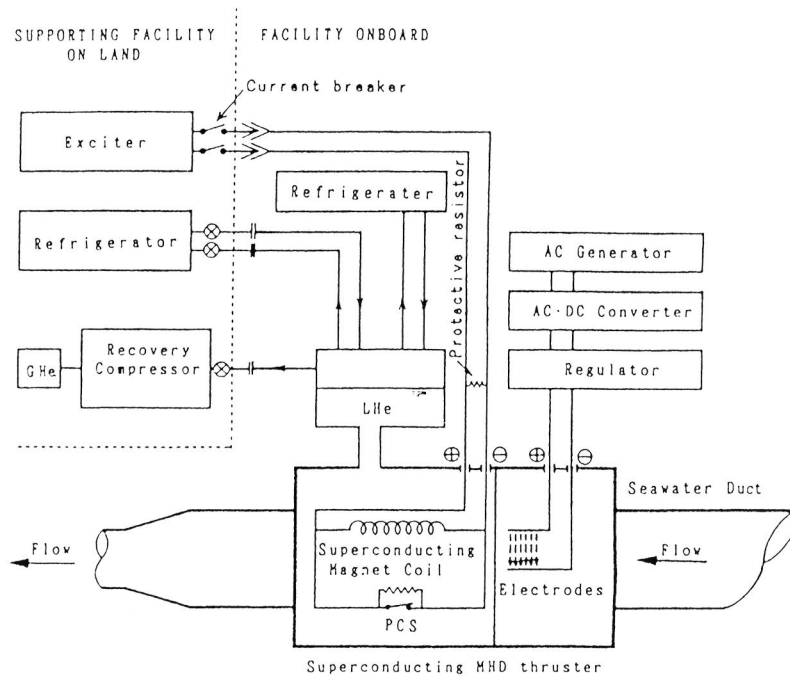

Fig.5 A schematic diagram of the total system of the YAMATO-1

NbTi wire is wound into a superconducting coil, which is of double-layered structure and cooled by being immersed in liquid helium; coil collars and vacuum vessels are made of aluminum alloy for the purpose of weight reduction; helium containers to accommodate superconducting coils are made of stainless steel which is widely adopted as a cryogenic material. Table 4 shows the specifications of the thruster, and Fig. 6 its dimensions. Fig. 7 is a cut-away view of the thruster, and Photo 3 the completed thruster.

The YAMATO's duct system per thruster consists of: an intake, a manifold or the portion branched into six tubes; the thruster tube, and another manifold or the portion where the six tubes are integrated into a single duct, which ends in a jet nozzle (Fig. 8).

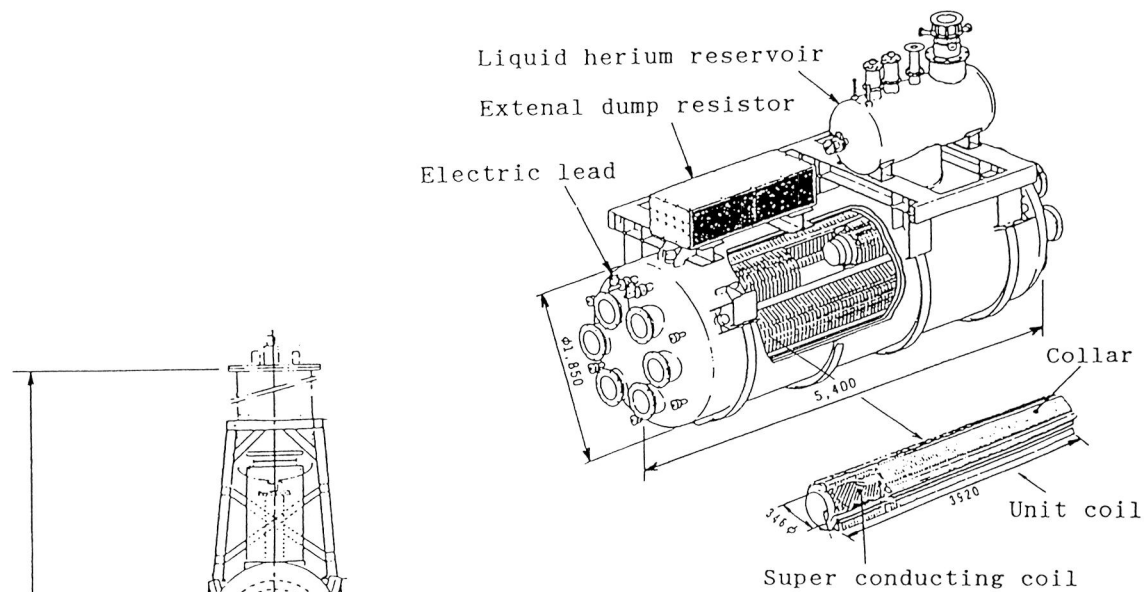

Fig.7 Cataway view of the MHD thruster

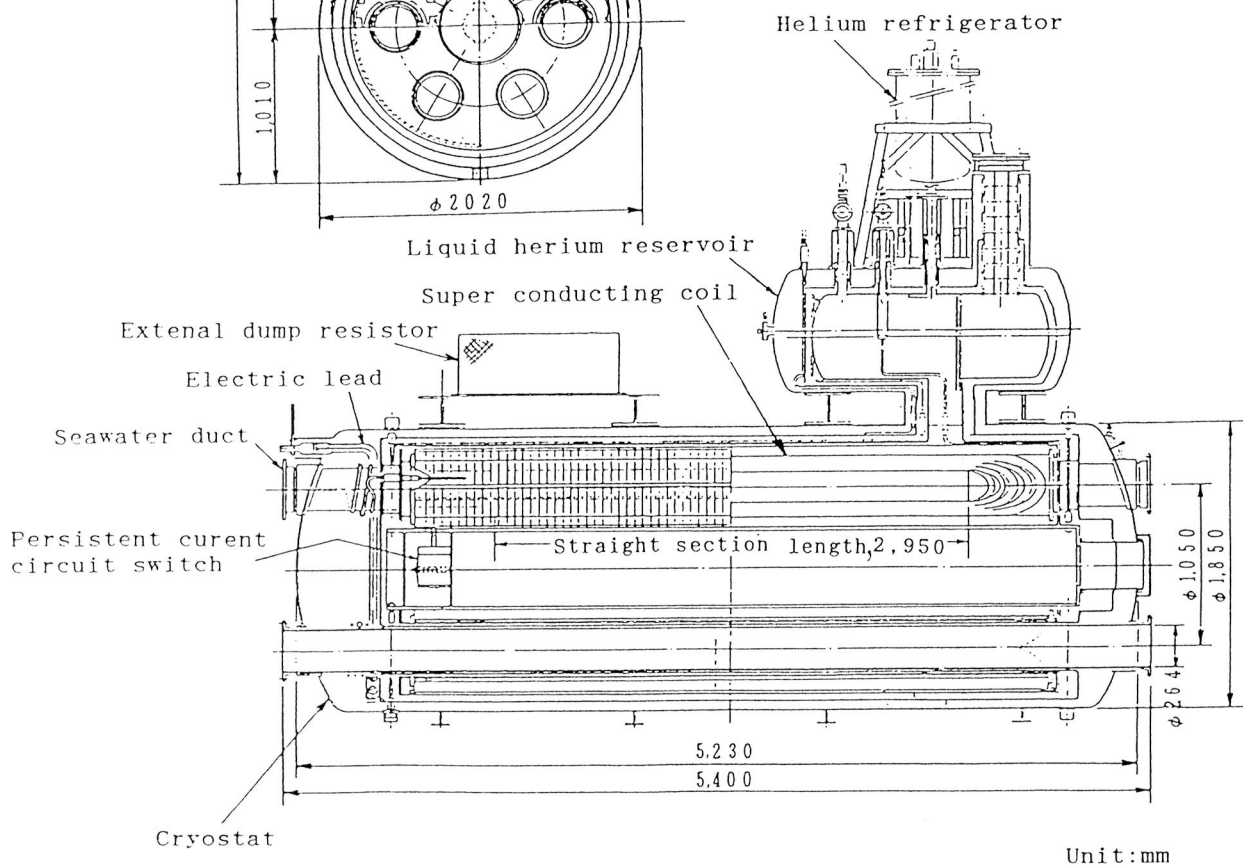

Fig.6 Principal dimensions of the MHD thruster

Table 4 Principal particulars of MHD thruster

		Magnet I (port)		Magnet II (starboard)	
Coil(unit)					
·Coil shape		Double shell type dipole			
·Cable material		Nb-Ti			
·Copper ratio		1.3		1.0	
·Dia.of winding	inner dia.	360 mm ϕ			
	outer dia.	405 mm ϕ		401 mm ϕ	
·Straight section length		3,000 mm		2,950 mm	
Coil(Fully assembled six coils)					
·Assembly circle dia.		1,050 mm			
·Inductance		3.3 H		3.7 H	
·Stored energy		23.0 MJ		20.0 MJ	
		unit	six coil	unit	six coil
·Field strength at bore center		3.5 T	4.0 T	3.5 T	4.0 T
·Maximum field on superconductor		5.5 T		5.9 T	
·Operation current		4,580 A	3,770 A	3,960 A	3,210 A
·Weight(with cryostat)		18.0 ton		15.8 ton	

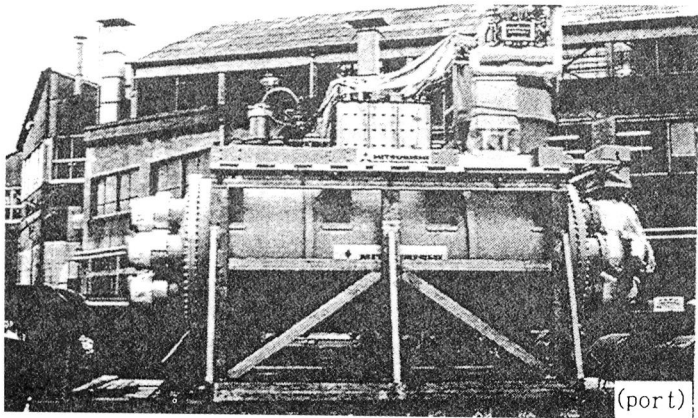

Photo 3 a Outside view of the MHD thruster

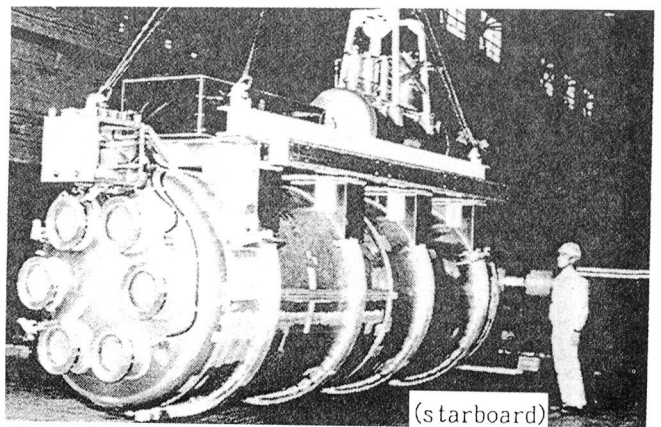

Photo 3 b Outside view of the MHD thruster

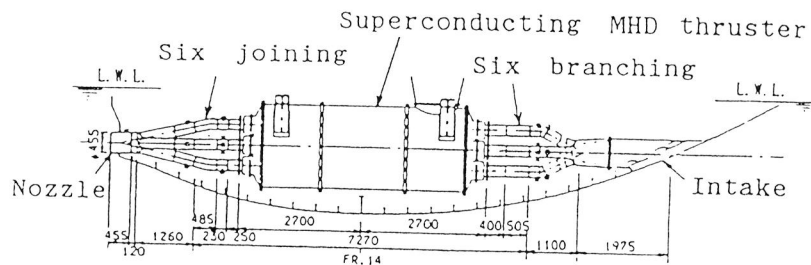

Fig.8 Configuration of the duct system

4. The results of sea trials

On January 27, 1991, the YAMATO-1 was put into the water. The YAMATO-1 underwent mooring tests and bollard-pull tests in preparation for sea running tests. In bollard-pull tests, the ship was moored to a bollard by use of rope furnished with a tension meter (Fig. 9); generated thrust was calculated from measurements of towing force and pressure inside the ducts. Fig. 10 shows the measurements. At a constant magnetic field density, towing force increases in proportion to electrode current. Towing force is larger than thrust. This is due to pressure distribution around the hull, which is different from that in case of navigation: a phenomenon recognized likewise for tugboats at work. Photo 4 is the YAMATO-1 under bollard-pull tests.

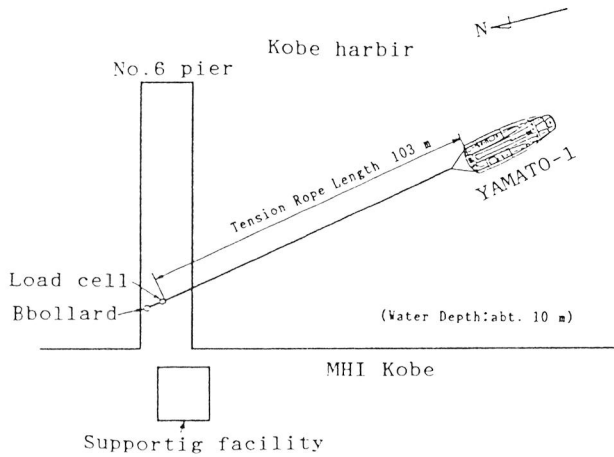

Fig.9 Bollared pull test arrangement

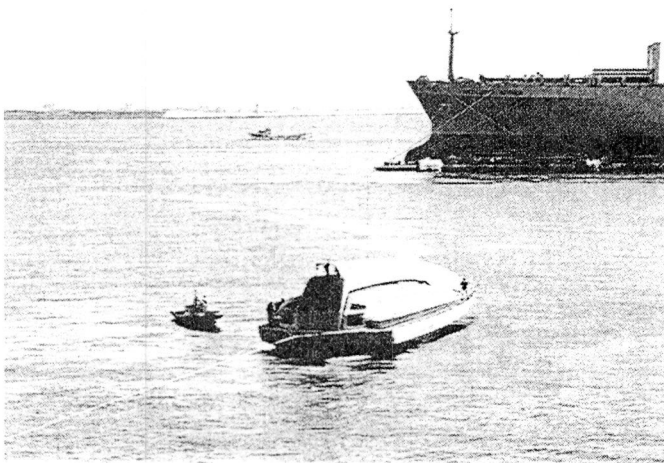

Photo 4 YAMATO-1 at the bollared pull test

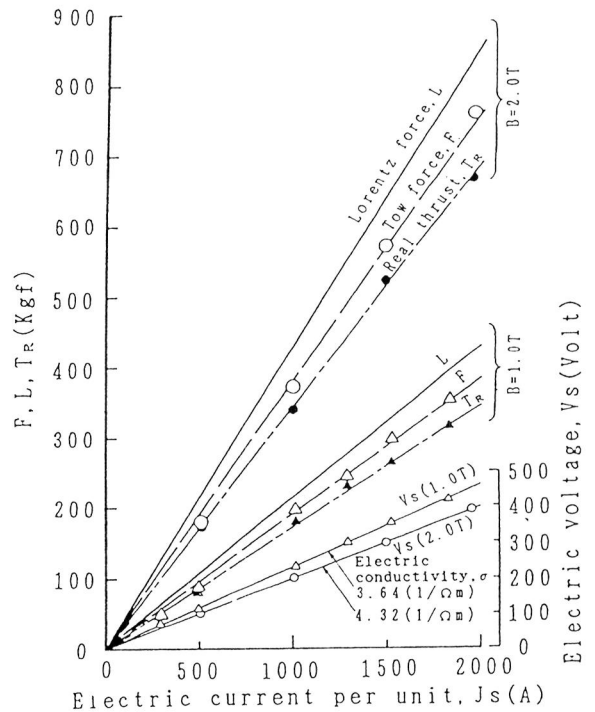

Fig.10 Result of the bollared pull test

Sea running tests started from June 16, 1992. Fig. 11 shows the ship's speed at a magnetic flux density of 1.0 Tesla, 1.5 Tesla, and 2.0 Tesla, respectively. Fig. 12 shows ship's speed at magnetic flux density of 1 through 4 Tesla and electrode current 2,000 A. Speed trial was performed at magnetic flux density of up to 2 Tesla, while mooring test at magnetic flux density of up to 3 Tesla; ship's speed at 4 Tesla was extrapolated to be some 7.5 knots from measurements at 1 to 3 Tesla; ship's speed of 5.3 knots in case of 2 Tesla. Photo 5 shows the YAMATO-1's sea running test in the harbor of Kobe.

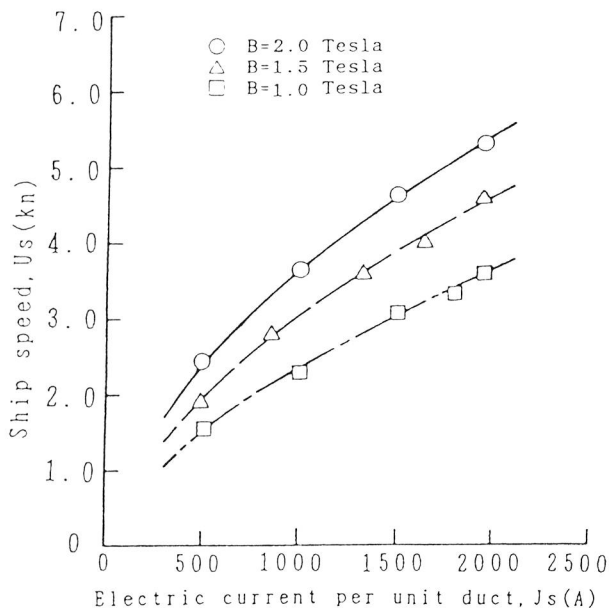

Fig.11 Result of speed trials(1)

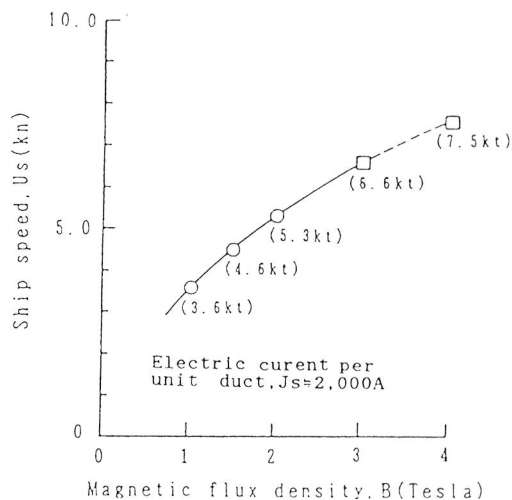

Fig.12 Result of speed trials(2)

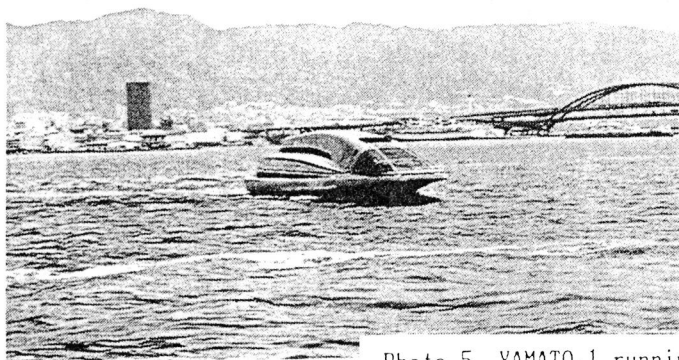

Photo 5 YAMATO-1 running in the harbor of Kobe

5. Conclusion

Superconducting MHD ship propulsion has just come out of laboratory, unable to vie in propulsion efficiency with ships using conventional modes of propulsion. Further R&D efforts are required to put the innovative propulsion system to practical use. Nonetheless, the YAMATO has proved that superconducting MHD ship propulsion, which was long considered impossible on account of structural problems involved and enormous weight of superconducting coils, could be practicable.