

N96- 10458

Wideband Propagation Measurement System Using Spread Spectrum Signaling and TDRS¹

Jeffrey D. Jenkins, Yiping Fan and William P. Osborne

Department of Electrical and Computer Engineering
New Mexico State University, Las Cruces, NM 88003

Abstract

In this paper, a wideband propagation measurement system, which consisted of a ground-based transmitter, a mobile receiver, and a data acquisition system, was constructed. This system has been employed in a study of the characteristics of different propagation environments, such as urban, suburban and rural areas, by using a pseudonoise spreading sequence transmitted over NASA's Tracking and Data Relay Satellite System. The hardware and software tests showed that it met overall system requirements and it was very robust during a 3-month-long outdoor data collection experiment.

1. Introduction

It is fundamental to have a good understanding of the channel characteristics in the planning and designing of mobile satellite systems. Otherwise, one will either suffer very poor system performance or come up with an unrealistic fading margin. Although many results have been presented in characterizing channels [1], more experimental and analytical works on propagation are needed, since the channels are statistical and frequency dependent in nature. As a part of the effort, a study of wideband propagation characteristics by using spread spectrum signaling over NASA's Tracking and Data Relay Satellite-F3 (TDRS-F3) was conducted. This study filled a gap in the propagation data base (model) of wideband signals at S-band and provided an experimental view of multipath phenomenon in real environments.

The study was divided into two phases. In the first phase, a wideband propagation measurement hardware and software system was developed. The field data collection and post data analysis were carried out in the second phase. Only the first phase work is discussed here². Since there is no standard product available for wideband propagation measurement, it is hoped the knowledge and experience gained in the development of this hardware system will be useful to others.

1 The authors wish to acknowledge the funding of this research under NASA grant NAG-5-2143, and for the arrangements which NASA made to permit the use of TDRS-F3 in making the propagation measurement.

2 Refer to [2], if interested in the second phase work.

The hardware system consisted of a transmitter, located at White Sands Ground Terminal (WSGT), a receiver in a van and a data acquisition system. Figure 1 shows how the system is used in a data collection experiment. A 1024-bit-long psuedonoise (PN) spreading signal was transmitted by WSGT at Ku-band and received by the NMSU mobile receiver at S-band, where td is the path delay of the line-of-sight signal and $tr1 + tr2$ is the path delay of one of the multipath signals. At the receiving end, a surface acoustic wave (SAW) matched filter tuned to this sequence will produce autocorrelation pulses whose amplitudes and time locations can be used to indicate symbol energy, fading depth, and multipath delay spread.

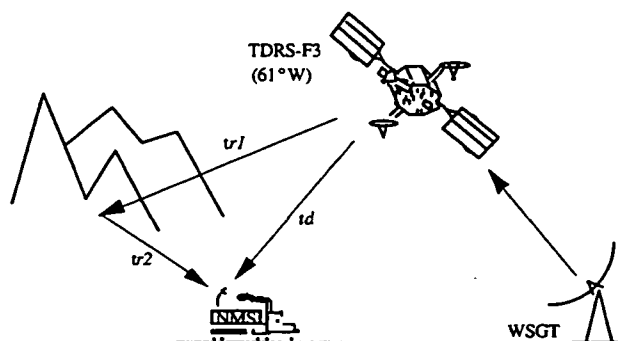

Figure 1. Wideband propagation measurement experiment

System parameters were selected based upon the availability of resources and system components as well as the existing system belonging to Mobile Datacom Corporation, which is representative of new mobile satellite spread systems which are currently under development.

A link analysis is given in Table 1 which indicates that the available E_s/N_0 is 26.1 dB. With the minimum E_s/N_0 required for signal detection of 5 dB, the resulting dynamic range of the measurement is 21.1 dB.

Table 1. Link budget

EIRP @ TDRS-F3	+ 47 dBW
Receiver Antenna Gain	+ 5.0 dBic
Free Space Path Loss @ 2090 MHz	- 191.8 dB
Carrier Power @ Ground	- 139.3 dBW
Antenna Temperature	300 K
LNA Temperature	124 K
System Temperature	235 K
kT_{sys}	- 204.9 dB
C/kT	+ 65.6 dB
Symbol Rate	+ 39 dB
E_s/N_0	+ 26.1 dB
Minimum E_s/N_0 for Detection	+ 5 dB
Dynamic Range	+ 21.1 dB

Before the hardware system was used in data collection, it was tested and verified in the lab using two input sources: (1) an IF source with varying E_s/N_0 ; (2) a RF source from TDRS-F3 with varying transmitting power. The test showed that the system met the data collection requirements and functioned over a dynamic range of 20 dB.

The measurement system has been applied to wideband data collection in 21 different geographical locations of the western and southeastern parts of the country in the summer of 1993. During this 3-month-long data collection campaign, this system was very robust and functioned very satisfactorily.

2. Wideband Propagation Measurement System

2.1 Transmitter

The transmitter hardware, located at White Sands Ground Terminal (WSGT), consisted of a PN-generator with an 8 MHz clock and a BPSK modulator. The general block diagram is shown in Figure 2.

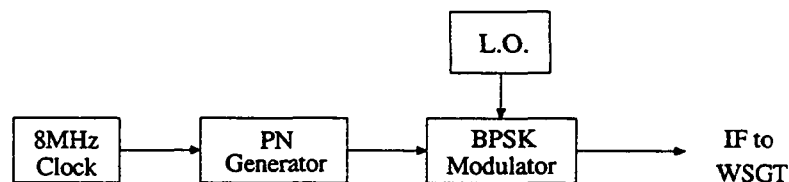

Figure 2. Block diagram of transmission equipment

The PN generator produced a 1024 chip sequence to match that of the SAW matched filter at the receiving end. This sequence consisted of four 256 bit code sequences in a non-inverted/inverted/non-inverted/non-inverted pattern. This means that the first sequence of 256 chips is the non-inverted code; the second one is the same code sequence, but inverted; the third and fourth 256 chip blocks are identical to the first sequence.

This 1024 chip sequence, driven by the 8MHz clock, was input to the BPSK modulator working at an intermediate frequency (IF) of 370.000 MHz to provide a spread spectrum signal operating at 8 MChips/sec with null-to-null bandwidth of 16 MHz. This spread spectrum signal was transmitted to TDRS-F3 by the WSGT at K-band unlink and received by the mobile receiver at S-band (2090 MHz) via the TDRS-F3 satellite downlink. WSGT transmitted the 1024 chip sequence continuously for the duration of the test.

2.2 Receiver

The receiver hardware set in the van consisted of an antenna, an S-band receiver, a SAW matched filter, and an envelope detector. The general block diagram of the receiver subsystem is depicted in Figure 3. The S-band receiver unit mixed the received signal with

the proper frequencies to bring the signal down to an intermediate frequency matching that of the SAW matched filter. The envelope detector converted the output of the matched filter into a baseband signal which was fed to the data acquisition system (DAS) for digitizing, sampling and data storage.



Figure 3. Block diagram of receiver equipment

Antenna

The antenna subsystem, mounted on the roof of the van, was composed of a Quad Helix antenna and a low noise amplifier (LNA). The Quad Helix antenna was selected to obtain omnidirectional coverage. It had a left hand circular polarization and a peak gain of 5 dBic. To minimize the SNR degradation due to cable loss between the antenna and the S-band receiver, a low noise amplifier with 20 dB gain was mounted immediately following the antenna. The electric field patterns of the antenna are depicted in Figure 4, (a) for an incident angle of 30° and rotation angle of $0^\circ - 360^\circ$ and (b) an incident angle of $0^\circ - 360^\circ$ and a rotation angle of 90° . These two antenna patterns were sufficient to cover all likely driving conditions in the data collection campaign.

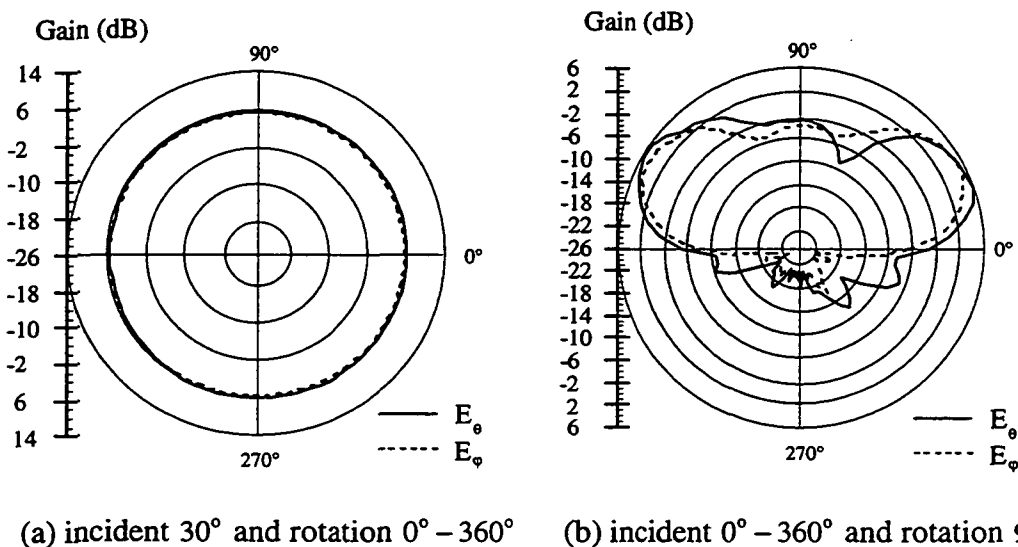

Figure 4. Antenna patterns

S-Band Receiver

The S-band receiver contained the down-conversion hardware as shown in Figure 5. The S-band signal from TDRS-F3 was received through the Quad Helix antenna and entered a band pass filter (BPF) centered at 2090 MHz to reject out-band noise. The

output of the BPF was mixed with a 1930 MHz source from L.O. 1 (HP8657B signal generator), and a second BPF was used to pass the desired frequencies centered at 160 MHz. The signal was mixed a second time, with 87.997 MHz supplied by L.O. 2 (HP-8656B signal generator). A 135 MHz low pass filter (LPF) was used to reject the mixer product of 247.997 MHz. The signal was then band-pass filtered at 75 MHz to isolate the required frequencies (centered at 72.003 MHz, i.e., the IF frequency of the SAW matched filter) of the mixer. This resulting signal was fed into the SAW matched filter. Several amplifiers and pads were used to provide isolation and the desired signal gain.

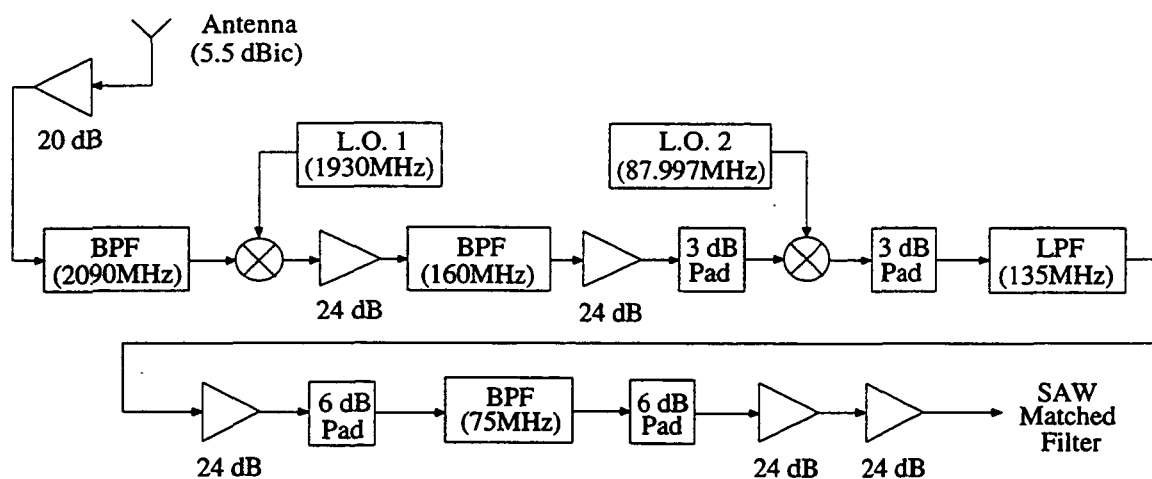

Figure 5. S-band receiver

SAW Matched Filter³

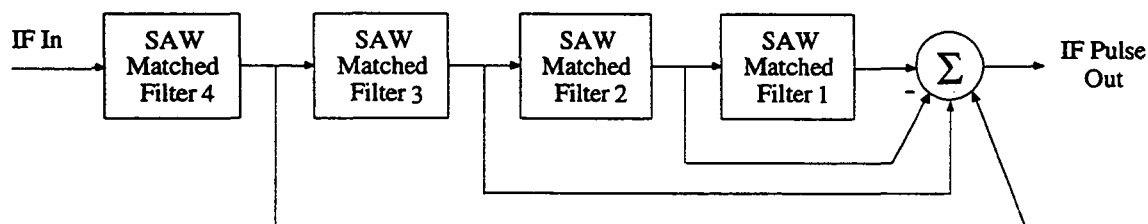

Figure 6. Matched filter configuration

The SAW matched filter converted the modulated PN sequence to an IF autocorrelation pulse. This special matched filter was comprised of four SAW sub-filters, as depicted in Figure 6 above. Each sub-filter matched the same 256-chip sequence of non-inverted code. Functionally, the third sub-filter matched to the 256-chip sequence of inverted code, because of its negative contribution to summer. This structure theoretically ensured that (1) when each sub-filter aligned with this 256-chip sequence and the received sequence pattern was non-inverted/inverted/non-inverted/non-inverted, the output of the matched filter would produced an IF autocorrelation pulse of width 250 ns, and (2) when

³ The SAW matched filter was supplied by Mobile Datacom Corporation.

either the pattern or the 256-chip sequence was misaligned, no output or noise with very small magnitude, would be generated. Figure 7 shows a typical output of the SAW matched filter in response to the 1024 PN sequence after the demodulation by the envelope detector. Since the DAS sampled only 1000 points per waveform at 50 MSa/s, Figure 7 gives a fraction (20 μ s out of 128 μ s) of the response around the autocorrelation pulse.

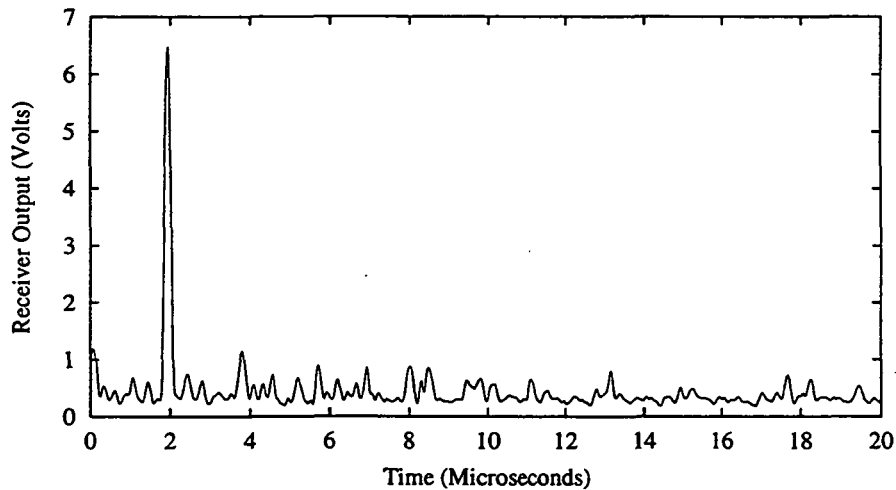

Figure 7. Typical response of the matched filter after demodulation

Envelope Detector

The IF output of the SAW matched filter was demodulated with the HP model 420B envelope detector. Because this particular envelope detector provided a negative pulse, it was inverted and then amplified to provide a baseband autocorrelation pulse.

2.3 Data Acquisition System

The DAS was responsible for the digitization, sampling and storage of the output of the SAW matched filter. Some basic functions of the DAS were:

- 1) Digitize, sample and store waveforms;
- 2) Acquire GPS data every minute;
- 3) Determine the synchronization state or lock condition;
- 4) Record multipath signals with maximal differential distance of 3 miles.

The autocorrelation pulse to be digitized was 250 ns wide (two-times the bit duration at 8 Mchips/sec). The pulse was sampled at 50 MSa/s. This gave 12 samples along the autocorrelation pulse to allow pulse reconstruction and peak estimation.

Objects within a few miles are of concern because they may cause significant multipath interference in received signals. Multipath signals from objects farther than a few miles away are attenuated to atmospheric noise levels and are therefore not necessary to

observe. It was necessary to digitize enough points so that a total multipath differential distance (distance traveled by the multipath signal minus that traveled by the direct signal) of several miles was included in the waveform record. At a sample rate of 50 MSa/s, a waveform with 806 samples was able to see a multipath distance less than or equal to 3 miles. For simplicity, the number of samples per waveform was selected to be 1000 which resulted in a total of 20 μ s of data per waveform. Accounting for 2 μ s of data, collected prior to the peak (Figure 8), a total of about 18 μ s was left for the autocorrelation pulse and multipath. Hence, the multipath effect which could be seen from the waveform had a maximal distance of 3.35 miles.

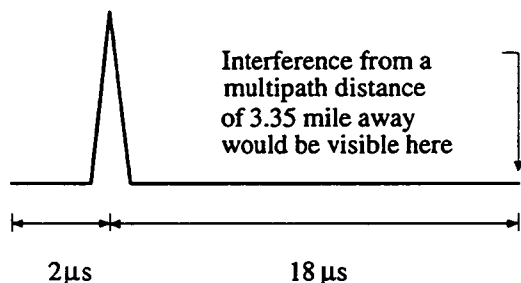

Figure 8. Theoretical Received Waveform

The DAS consisted of a frame synchronizer, a GPS antenna, a GPS receiver card, an HP digitizing oscilloscope, a 486-33 MHz computer and a tape backup system. A video camcorder was also present to record actual paths traversed by the van. This allowed us in part to review weather conditions and objects causing interference in data analysis. A general block diagram of the DAS equipment is shown in Figure 9.

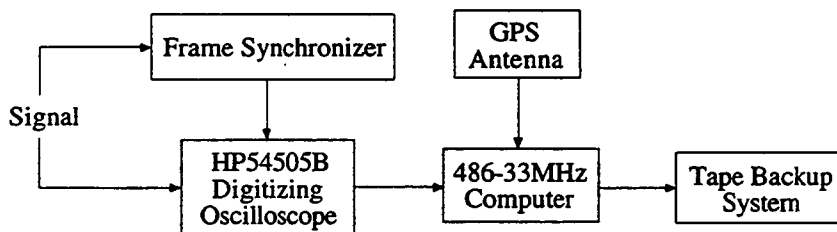

Figure 9. Block diagram of the DAS

Frame Synchronizer

The baseband autocorrelation pulse from the envelope detector was supplied to the frame synchronizer. The frame synchronizer board used a digital phase locked loop design to acquire and track a pulse of known period. The circuit then provided an external trigger pulse to the oscilloscope signifying both the lock condition of the board and the imminent occurrence of the tracked pulse within a known window of time so that data could be sampled. Figure 10 is a block diagram of the frame synchronizer.

In a locked condition, the incoming pulse occurred within a "look" window. If the pulse was away from the center of the window, a feedback mechanism was involved such

that the VCO input voltage was altered which forced the center of the window tracking the incoming pulse. Board timing was derived from two counter circuits. The first circuit operated at 16 MHz and consisted of a 24 bit counter used to set the desired pulse period. The second counter circuit operated at 2 MHz and adjusted the length of the window.

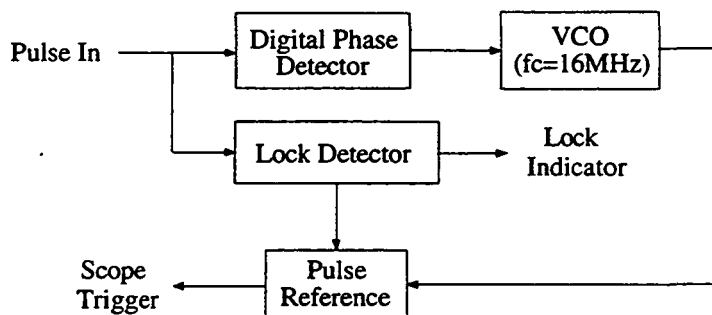

Figure 10. Frame synchronizer block diagram

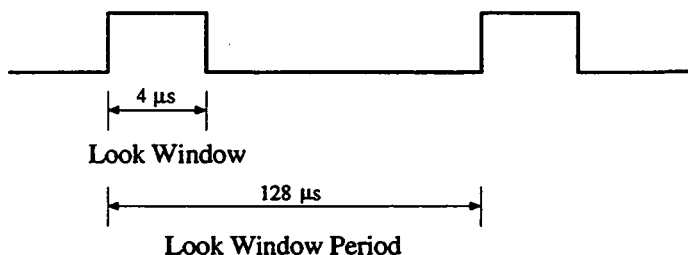

Figure 11. Frame timings

The look window period (Figure 11) was selected to be 128 μ s which was the elapsed time between autocorrelation pulses generated by the matched filter. The window duration was selected to be 4 μ s, 16 times the pulse width of 250 ns.

The lock detector circuit was also built to indicate the lock condition. The lock condition remained in effect as long as pulses occurred in the window. This sustained lock allowed the system to momentarily lose the incoming pulse and still maintain the same location in time to find it when it came back (should it be lost due to a short duration fade). The maximum time to remain in lock without a pulse was approximately 20 ms. When the circuit was out of lock, any pulse occurring within the window reset the period counter and lock was instantaneously achieved.

GPS Antenna

The GPS antenna allowed the NOVATEL Model 711 GPS receiver card, located inside the computer, to receive data from the GPS satellites. The GPS receiver card gave GPS time, latitude, longitude, altitude and standard deviations of those measurements.

HP Digitizing Oscilloscope

The HP54505B digitizing oscilloscope sampled the auto-correlation pulse from the envelope detector in the receiving equipment. The trigger pulse created by the frame synchronizer was fed directly into the scope trigger input. The 486-33MHz computer controlled the digitization process via IEEE-488 interface. The HP54505B digitizing oscilloscope was selected due to its 125 MHz bandwidth, 500 MSa/sec maximum sample rate and versatility.

486-33 MHz PC

The 486-33MHz computer with 32 Mbytes of RAM, controlled the digitization, collection, and storage of waveform data. It also controlled the collection and storage of GPS data. Writing to the hard drives while in transit could damage them. To overcome this problem, 28 Mbytes of RAM was configured into virtual RAM drives. With the Quarterdeck memory manager software, the largest configurable size of a RAM drive was 4096 KBytes, so 7 virtual drives (each with 4 Mbytes) were created. It took 3 seconds to digitize, transfer and store 30 waveforms and took about 20 minutes to fill all 7 RAM drives with data. After 7 RAM drives were full of waveform data, the DAS prompted the user to stop the van so that a safe transfer from volatile RAM to the hard drive could be executed.

Because GPS data was collected every minute, a means to correlate the GPS information to waveform record was required. A CPU time and GPS number was introduced in the data format (Figure 12) to achieve this correlation. At the beginning of a collection, the GPS number was zero and GPS data was collected, followed by a number of groups of 30 waveforms. Each time a new group of 30 waveforms was collected, and the elapsed time was less than 60 seconds, the GPS number was incremented. When 60 seconds had elapsed, a new GPS fix was collected and the GPS number was reset to zero. Therefore, GPS data was directly correlated to the time a group of 30 waveforms was collected by noting when the GPS number was zero. Since each sample took 16 bits, one waveform record with 1000 samples occupied 2000 bytes.

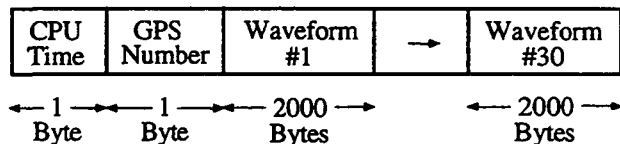

Figure 12. Data format for 30 waveforms

Tape Backup System

The tape backup system was the Colorado Jumbo 250 MByte Tape drive and software. This was used to back-up the hard drive data at the end of each days

measurement. It was necessary to clear the hard drives of all waveform data before a new data run could be executed.

3. System Test

Once the transmitter, receiver and data acquisition system were constructed, in-lab tests were conducted to confirm proper operation and to examine system performance. Two kinds of tests were done: (1) IF loop-back; (2) satellite reception of signals from TDRS-F3.

In-lab IF loop-back

In this test, the 1024-chip PN sequence, with BPSK modulation at an IF of 72.003 MHz, was supplied to the SAW matched filter. This test confirmed proper PN sequence generation, matched filter operation, demodulation, frame synchronization and DAS operation. Through varying E_s/N_0 of the input signal, these subsystems were checked over the entire operating range. Figure 13 shows the output voltage at the envelope detector with a varying E_s/N_0 from 25 dB to 5 dB in one decibal steps. The time indices from 1 to 30 correspond to an input E_s/N_0 of 5 dB. The next group of 30 indices has a E_s/N_0 of 6 dB, and so on. Therefore, the last group of indices from 600 to 630 represents an input E_s/N_0 of 25 dB. It was seen that although there was a nonlinear relation between the input and the output (primarily due to the envelope detector), this relation was consistent as expected. The test also showed that this system functioned over a dynamic range of 20 dB which was almost identical to the theoretical range of 21.1 dB given in Table 1, accounting for there were some uncertainties in the link budget calculation.

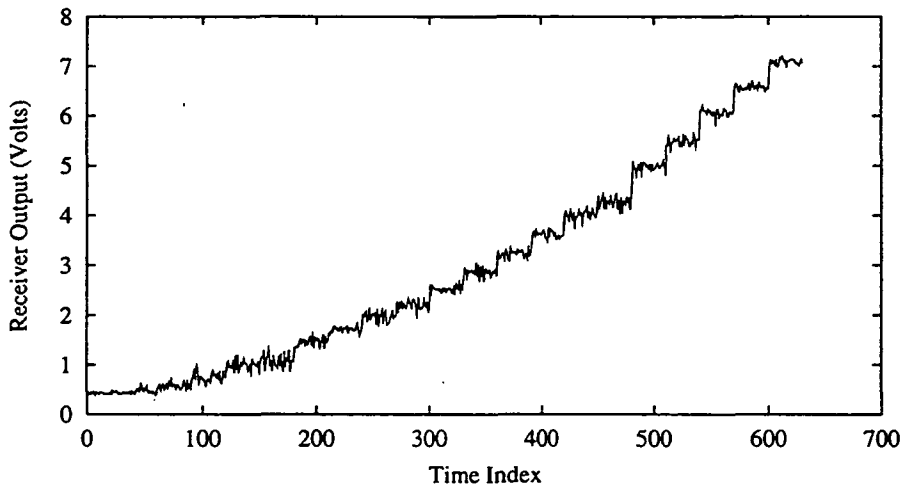

Figure 13. Voltage at receiver output during system calibration

In-lab satellite reception

The in-lab reception of the PN sequence from TDRS-F3 tested all subsystems in the entire link from the transmitter to DAS. During the test, TDRS-F3 alternately transmitted the PN signal and carrier so that E_s/N_0 level could be analyzed. The entire range of E_s/N_0 was checked by varying the transmitted power of TDRS-F3. Figure 14 shows the actual E_s/N_0 vs the observed E_s/N_0 in dB. The actual E_s/N_0 was varied approximately 2 dB each step. The test data was indicated by the points and the curve fitting was represented by the solid line. This fitting curve of the 3rd order polynomials was used to compensate the nonlinearity of the measurement system in propagation data processing so that the actual signal strength level could be restored. Again, the input-output relationship was consistent and the test was a success.

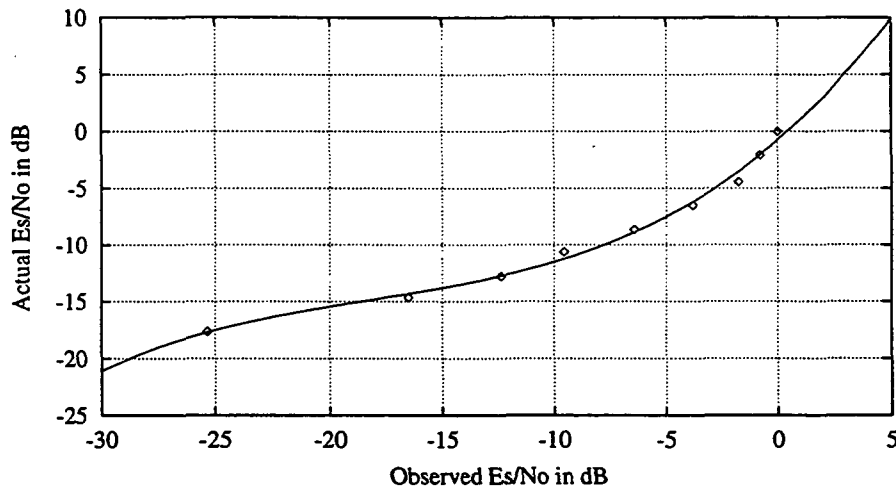

Figure 14. Measurement system calibration curve input vs output

4. Conclusions

A spread spectrum measurement system, which consisted of a ground-based transmitter, a mobile receiver and a data acquisition system, was fabricated. Two kinds of tests demonstrated that the system met the requirements for the data collection. This system allowed us to conduct experimental studies of channel fading by using spread spectrum signaling over NASA's Tracking and Data Relay Satellite. It has been used in a data collection campaign in many different geographical areas, including cities, canyons, prairies, wooded tree roads, etc. During the 3-month-long operation, the system was very robust and functioned very satisfactorily. Since the system used the spread spectrum technique, it was also capable of measuring multipath phenomena.

References

- [1] Goldhirsh, J. and W. J. Vogel, " Propagation Effects for Land Mobile Satellite Systems: Overview of Experimental and Modeling Results ", NASA Reference Publication 1274, February 1992.
- [2] Jenkins, J. D., Y. Fan and W. P. Osborne, "Channel Fading for Mobile Satellite Communications Using Spread Spectrum Signaling and TDRSS", Proc. NAPEX XIX, June, 1995.
- [3] Goddard Space Center, " Performance Specification for Service via the Tracking and Data Relay Satellite System ", Revision C, July 1989.
- [4] Osborne, W. P. and W. Drozdick, Jr., " Data Acquisition System for S-band Propagation Study ", Technical Report, NMSU-ECE-93-019, December 1993.

Acknowledgment

The authors wish to thank Steve Kelly for his efforts in system fabrication and installation, Al Carrier, Abe Valdez, Ted Wolcott and Bill Drozdick for their work in system fabrication and test, and Bill Linde for his software development of DAS. The authors would also like to thank Dr. Les Snively of Mobile Datacom Corporation for supplying the 1024-bit SAW matched filter used in the receiver. This study was supported by NASA under Grant #NAG 5-2142.