

INTERIM
IN-34-CN

Scientific Research Associates, inc.

50 Nye Road, P.O. Box 1058
Glastonbury, CT 06033
(203) 659-0333 FAX (203) 633-0676

5049

NASA-CR-199478

P-21

NAS3-27378

FLOW IN SERPENTINE COOLANT PASSAGES WITH TRIP STRIPS

R95-9089-10

Technical Progress Narrative Report

Reporting Period September 1, 1995 to September 30, 1995

N96-11022

Unclass

G3/34 0068150

D.G-N. Tse

October 1995

Prepared for

NASA Lewis Research Center
Cleveland, OH 44135

(NASA-CR-199478) FLOW IN
SERPENTINE COOLANT PASSAGES WITH
TRIP STRIPS Progress Report, 1-30
Sep. 1995 (Scientific Research
Associates) 21 p

Scientific Research Associates, inc.

50 Nye Road, P.O. Box 1058
Glastonbury, CT 06033
(203) 659-0333 FAX (203) 633-0676

October 5, 1995

Dr. Phil Poinatte
NASA/Lewis Research Center
Mail Stop 5-11
21000 Brookpark Road
Cleveland, OH 44135

Subject: Contract No. NAS3-27378; Technical Progress Report for period September 1, 1995 - September 30, 1995.

Dear Dr. Poinatte:

Under the subject contract, an effort is being conducted at Scientific Research Associates, Inc. (SRA) to obtain flow field measurements in the coolant passage of a rotating turbine blade with ribbed walls, both in the stationary and rotating frames. The data obtained will be used for validation of computational tools and assessment of turbine blade cooling strategies.

During the current reporting period, Task 5 (Final Report and data analysis) were active. Tangential and Cross-stream velocity measurements for Configuration D will be presented in this report.

The configuration of the turbine blade passage model is given in Figure 1, and the measuring plane locations are given in Table 1. The model has a four-pass passage with three 180° turns and is approximately equivalent to that of Wagner, et al. (1994). This geometry was chosen to allow analyses of the velocity measurements corresponding to the heat transfer results obtained by Wagner, et al. (1994). Two passes of the passage have a rectangular cross-section of 1.0" x 0.5". Another two passes have a square cross-section of 0.5" x 0.5". Trips with a streamwise pitch to trip height (P/e) = 5 and trip height to coolant passage width (e/Z) = 0.1, were machined along the leading and trailing walls. These dimensions are typical of those used in turbine blade coolant passages. The trips on these walls are staggered by the half-pitch. The trips are skewed at $\pm 45^\circ$, as shown in the figure, and this allows the effect of trip orientation to be examined. Experiments will be conducted with flow entering the model through the 1.0" x 0.5" rectangular passage (Configuration C) and the 0.5" x 0.5" square passage (Configuration D) to examine the effect of passage aspect ratio.

ORIGINAL PAGE IS
OF POOR QUALITY

Velocity measurements were obtained with a Reynolds number (Re) of 25,000, based on the hydraulic diameter of and bulk mean velocity in the half inch square passage. Figure 2 shows the coordinate system used in presenting the results for configurations C and D, respectively. The first, second and third passes of the passage will be referred to as the first, second and third passages, respectively, in later discussion. Streamwise distance (x) from the entrance is normalized by the hydraulic diameter (D). Vertical (y) and tangential (z) distances are normalized by the half passage height (H) and width (Z), respectively. The x coordinate and U component are positive in the streamwise direction. The y coordinate and V component are positive against gravity. The z coordinate and W component are positive in the direction of rotation. The velocities are normalized by the bulk mean velocity (U_b) of 3.44 ms^{-1} , based on the half-inch square passage. The contours of the 1.0" x 0.5" and 0.5" x 0.5" passages were evaluated from 11 x 30 and 9 x 30 measurement grids, respectively.

Figures 3 and 4 show the mean tangential velocity contours obtained at $x/D = 1$ and 4, Station D1 and D2. Figure 3 shows positive tangential velocity near the upper and lower wall and negative tangential velocity at the center of the passage. A two-vortex structure has been established at $x/D = 1$. The maximum positive and negative velocities reach $\pm 0.18 U_b$. The lower vortex extends above the center of the passage. This is consistent with convection of the cross-flow to the upper half of the passage observed in the streamwise velocity measurements, Tse et al (1995). Figure 4 shows positive tangential velocity near the lower wall and negative tangential velocity above the center of the passage. The negative velocity extends to the upper wall, indicating further expansion of the lower vortex at $x/D = 4$.

Figures 5 to 7 show the tangential and vertical velocity components in velocity vector form obtained at $x/D = 7, 10,$ and 12.75 : Station D3, D4 and D5. With clockwise rotation of the rig (viewed from the top), the combination of radially outward flow and trips skewed at -45° generates counter-clockwise swirl (viewed radially outward) and a corner recirculation zone. The stationary measurements show that the secondary flow in the passage is characterized by a two-vortex structure with upward velocity at the center and downward velocity near the wall in the absence of rotation, Figure 8.1. Rotation induces a second two-vortex structure with negative tangential velocity in the center and positive tangential velocity near the upper and lower walls, Figure 8.2. It is evident from Figures 8.1 and 8.2 that each of these two-vortex structures has a clockwise circulating vortex and a counter-clockwise circulating vortex. The two counter-clockwise vortices reinforce each other and give rise to the counter-clockwise swirl observed in the cross-flow, Figure 8.3. The vortices circulating in the clockwise direction are compressed to form a corner recirculation. The maximum tangential velocities at $x/D = 4, 7, 10,$ and 12.75 are respectively $0.48, 0.65, 0.71,$ and $0.72 U_b$. The secondary flow is asymptotic.

The study of Prakash and Zerkle (1993) shows that the flow in a rectangular duct with normal trip strips and an aspect ratio (H/Z) of 0.5 is characterized by a two-vortex structure for $Ro = 0.12$. Coriolis effects are less pronounced in a ribbed passage compared to a smooth wall passage. Separation and re-attachment of the boundary layer in the inter-rib region prevents Coriolis effects from reaching the walls. Separation and re-attachment of the boundary layer occur on both the leading surface and the trailing surface at alternate intervals. Augmentation of heat transfer stems from re-attachment of the boundary layer which brings the cool cross-flow to the surface.

However, in a square duct with skewed trip strips, Figures 5 to 7 show that, for $Ro = 0.24$, the flow is characterized by a large counter-clockwise swirl bubble and a small corner recirculation. With skewed trips, separation and re-attachment of the boundary layer in the inter-rib region mainly occurs on the leading surface. The counter-clockwise swirl and corner recirculation flow structure leads to re-attachment of the boundary layer in the upper and lower corners and separation in the center of the passage. Separation and re-attachment of the boundary layer on the trailing surface is not noticeable because of the high cross-stream velocity associated with the strong counter-clockwise swirl. The difference between the secondary flow characteristics inferred here and those evaluated from the theoretical analysis of Prakash and Zerkle (1993) may stem from differences in trip orientation and passage configuration.

Figure 9 shows the streak lines obtained in the first turn, Station D6. The secondary flow at the turn is characterized by a clockwise swirl (view against the upstream direction). The direction of the swirl is counter-clockwise when viewed from the upstream direction. The counter-clockwise swirl present in the first passage is reinforced by the centrifugal force generated by the rotation of the rig and by the centripetal force created by the C-turn. The corner recirculation zone is eliminated by the expansion of the swirl bubble.

Figures 10 and 11 show the tangential and vertical velocity components in velocity vector form obtained at $x/D = 16.25$, and 18.25 , Station D7 and D8: which are located 1 and 3 D downstream of the first turn. The cross-stream component can not be obtained at $y/H = +0.8$ for $x/D = 16.25$ and at $y/H = +0.6$ and 0.8 for $x/D = 18.25$. At these vertical locations only the tangential components are plotted so at these locations the plotted vectors do not indicate flow direction. The flow in the second passage is characterized by a clockwise swirl (viewed radially outward) and a corner recirculation. The second passage is a radially inward flow passage with trips skewed at $+45^\circ$. Stationary measurements presented in Tse (1994) show the combination of radially inward flow and trips skewed at $+45^\circ$ generates a two-vortex structure with upward velocity at the center and downward velocity near the wall, Figure 12.1. The two-vortex structures induced by the trips in the first and second passages are the same because of the reversal of both trip orientation and flow direction. The direction of Coriolis force is reversed,

Figure 12.2. In the second passage, the two clockwise vortices reinforce each other and give rise to the clockwise swirl observed in the cross-flow, Figure 12.3. The vortices circulating in the counter-clockwise direction are compressed to form a corner recirculation.

Figures 13 and 14 show the mean tangential velocity contours obtained at $x/D = 25$ and 26, stations D9 and D10. The contours are consistent with those associated the streak lines presented in Figure 10 and 11. The entire second passage is characterized by a clockwise swirl bubble and a corner recirculation.

Tangential and cross-stream velocities were obtained in the second turn. They will be presented in the final report. The results presented here will be further analyzed in relation to the heat transfer measurement of Johnson et al (1994).

Current costs and work accomplished are consistent with those of the original schedule, as shown in Report 533P. No change is estimated in the original estimate for cost to complete the contract.

The technical effort in the next reporting period will focus on analyzing the tangential and cross-stream velocity components of Configuration C.

At the end of the reporting period, approximately 90% of the contract effort has been completed.

R95-9089-10
Oct. 5, 1995
Page 5

Pratt & Whitney's progress report is attached as an appendix. All of Pratt & Whitney's costs have not yet been included in the billing.

Very truly yours,

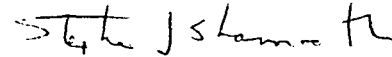

Stephen J. Shamroth,
President

SJS:jc

cc: Procurement Assistant, M.S. 500-305 (2 copies)
NASA Ctr. For Aerospace Info. (CASI) (2 copies)
Attn: Accessioning Dept.
800 Elkridge Landing Rd.
Linthicum Heights, MD 21090-2934

K. Civinkas - NASA Lewis Research Center, MS 77-6
David Rigby - NASA Lewis Research Center, MS 5-11
Le Tran - 2001 Aerospace Parkway, Brookpark, OH 44142
Gary Steuber - P&W
Joel Wagner - UTRC

R95-9089-10

Oct. 5, 1995

Page 5

A.

Pratt & Whitney's progress report is attached as an appendix. All of Pratt & Whitney's costs have not yet been included in the billing.

Very truly yours,

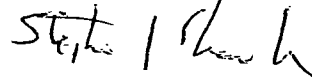

Stephen J. Shamroth,
President

SJS:jc

cc: Procurement Assistant, M.S. 500-305 (2 copies)
NASA Ctr. For Aerospace Info. (CASI) (2 copies)
Attn: Accessioning Dept.
800 Elkridge Landing Rd.
Linthicum Heights, MD 21090-2934

K. Civinkas - NASA Lewis Research Center, MS 77-6
David Rigby - NASA Lewis Research Center, MS 5-11
Le Tran - 2001 Aerospace Parkway, Brookpark, OH 44142
Gary Steuber - P&W
Joel Wagner - UTRC

References

- Johnson, B.V. Wagner, J.H., Steuber, G.D., and Yeh, F.C., (1994), "Heat Transfer in Rotating Serpentine Passages with Trips Skewed to the Flow," ASME Journal of Turbomachinery, Vol. 116, pp -113-123.
- Prakash, C., and Zerkle, R., (1993), "Prediction of Turbulent Flow and Heat Transfer in a Ribbed Rectangular Duct with and without Rotation," Paper presented at the Cincinnati, Ohio May 24-27, 1993.
- Tse, D.G.N., (1995), "Flow in Serpentine Passages with Trip Strips," SRA monthly report R95-9089-4.
- Wagner, J.H., (1994), Personal communication.

TABLE 1

Location	
D1	1 D downstream of the inlet
D2	4 D downstream of the inlet
D3	7 D downstream of the inlet
D4	10.25 D downstream of the inlet
D5	12.75 D downstream of the inlet
D6	First turn
D7	1 D downstream of the first turn
D8	3 D downstream of the first turn
D9	9.5 D downstream of the first turn
D10	11.5 D downstream of the first turn
D11	Second turn
D12	1 D downstream of the second turn
D13	6 D downstream of the second turn

List Of Figures

- 1 Measuring location for Case D.
- 2 Coordinate system.
- 3 Tangential velocity contours at D1.
- 4 Tangential velocity contours at D2.
- 5 Streak lines at D3.
- 6 Streak lines at D4.
- 7 Streak lines at D5.
- 8 Two-vortex structure for radially outward flow and trips skewed at -45° .
- 9 Streak lines at D6.
- 10 Streak lines at D7.
- 11 Streak lines at D8.
- 12 Two-vortex structure for radially inward flow and trips skewed at $+45^\circ$.
- 13 Tangential velocity contours at D9.
- 14 Tangential velocity contours at D10.

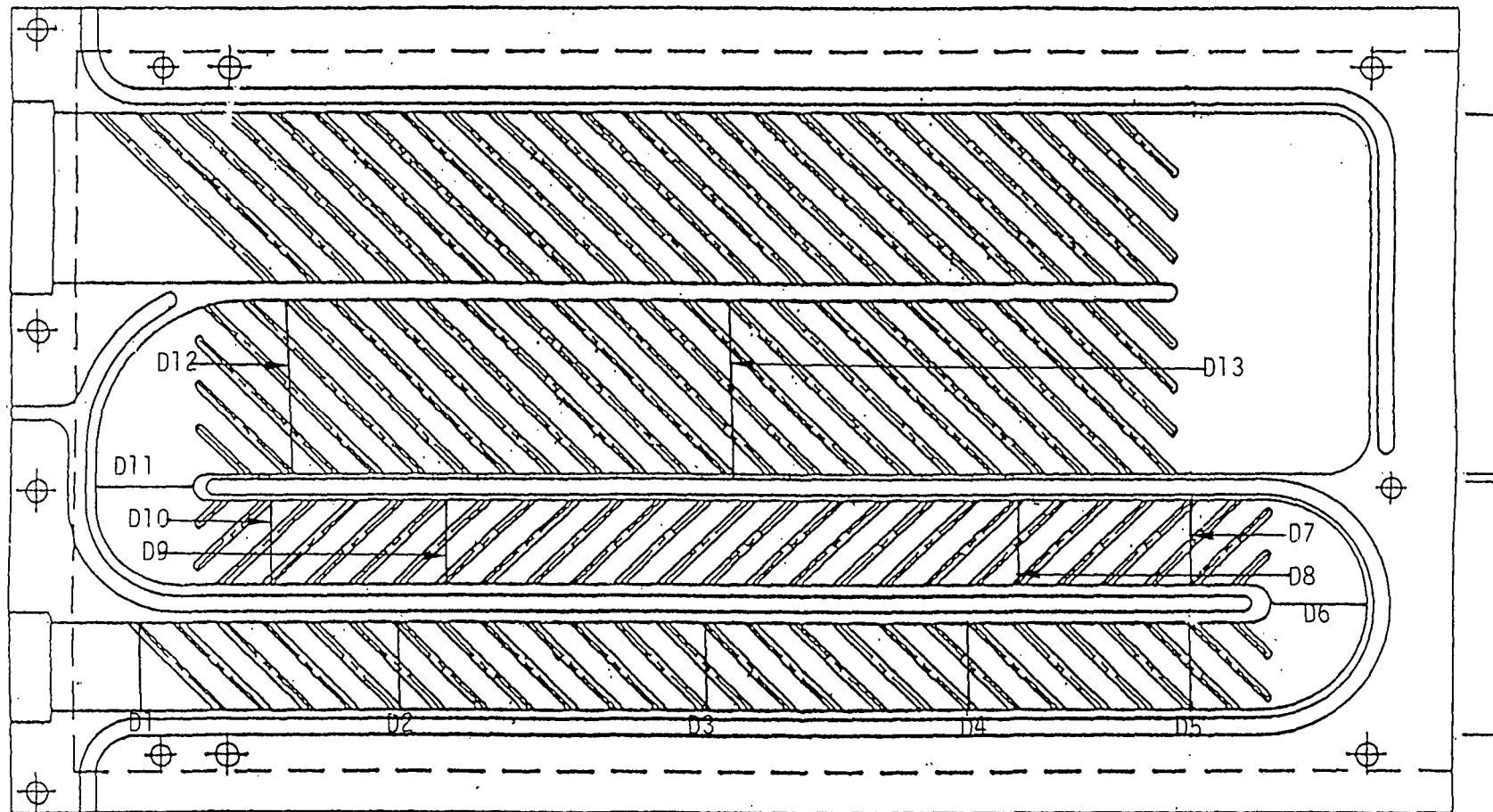

FIGURE 1

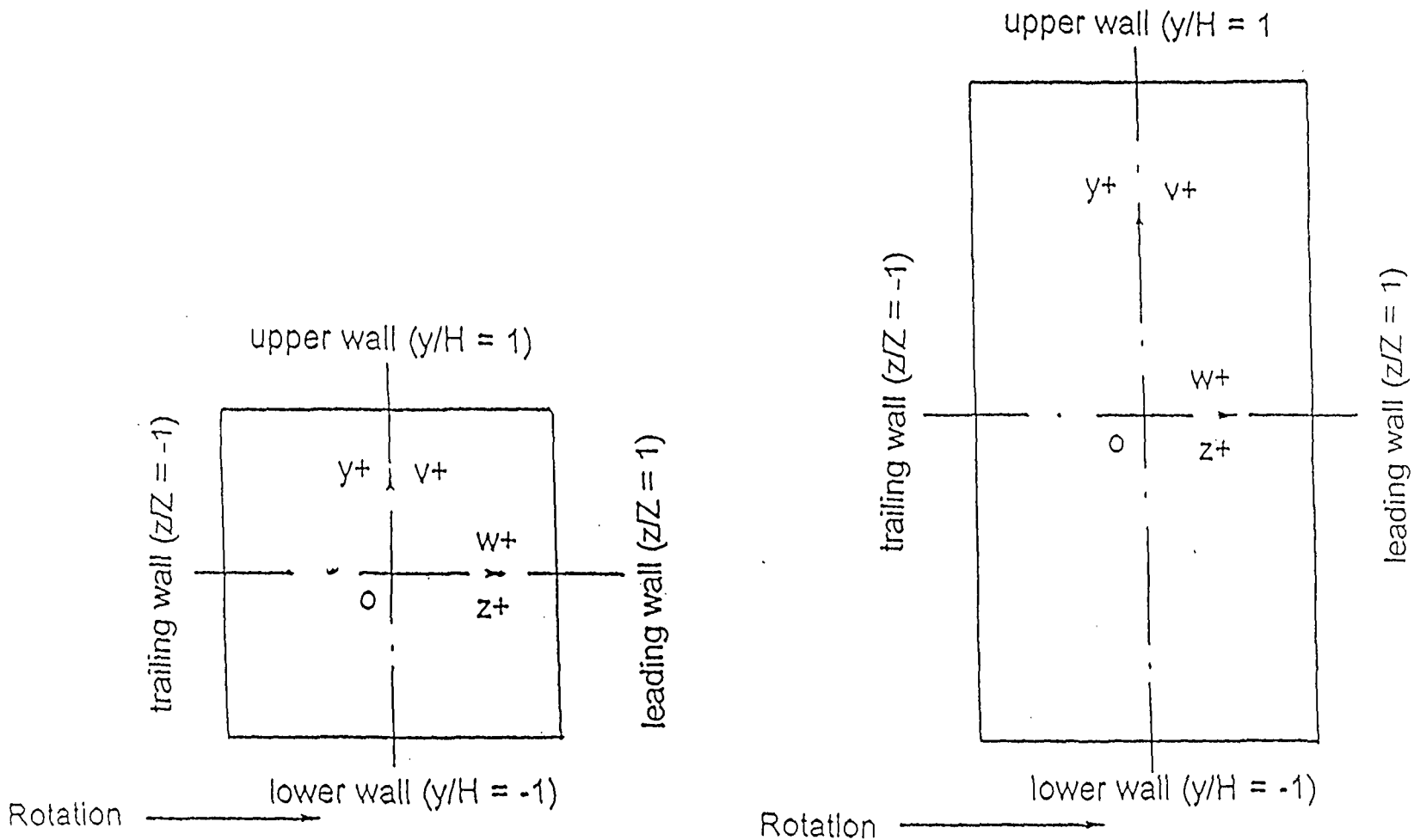

FIGURE 2

Velocity

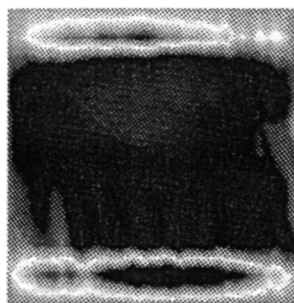
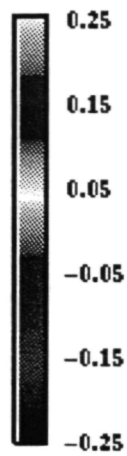

FIGURE 3

Velocity

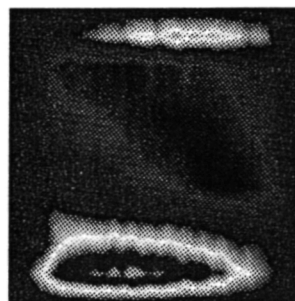
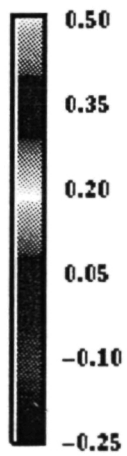

FIGURE 4

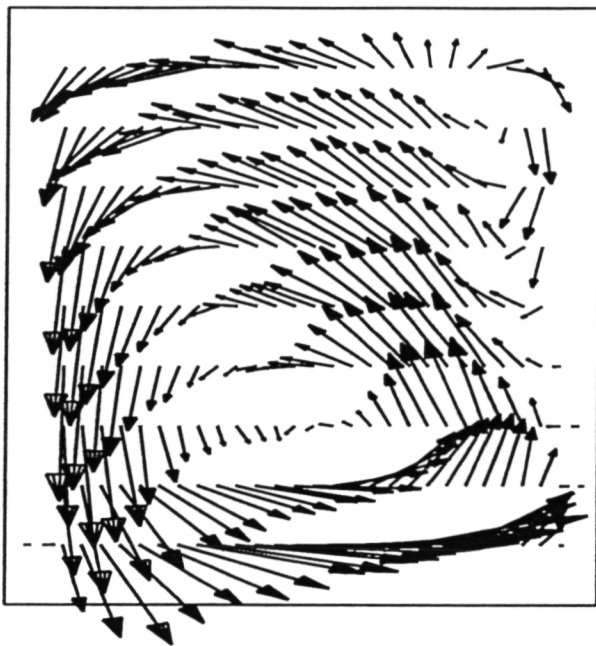

FIGURE 5

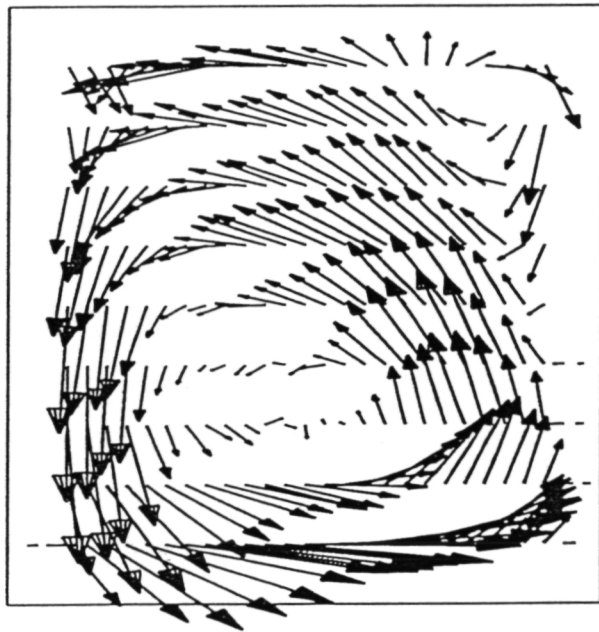

FIGURE 6

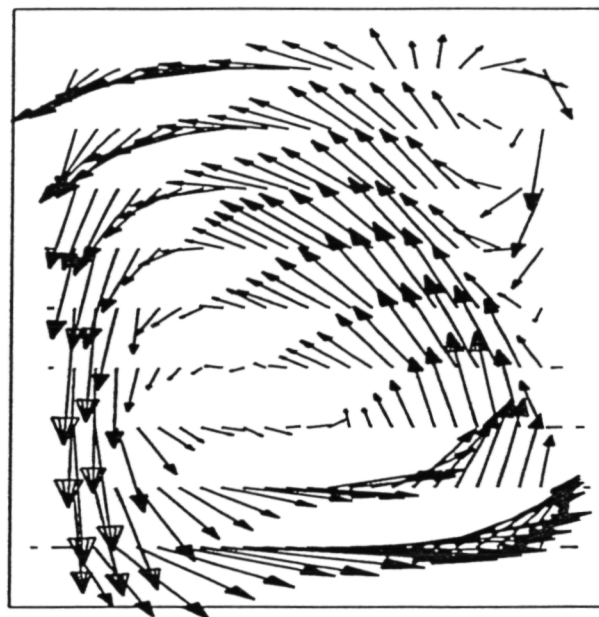

FIGURE 7

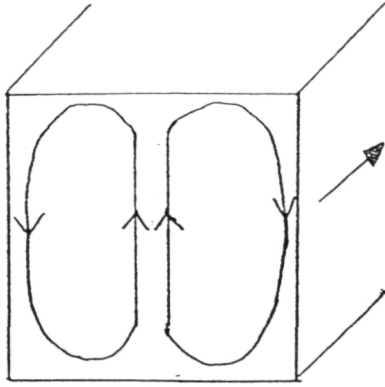

FIGURE 8.1 - DOUBLE VORTEX INDUCED BY THE TRIPS

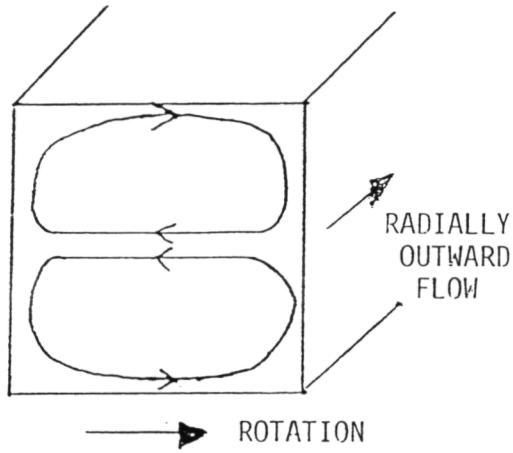

FIGURE 8.2 - DOUBLE VORTEX INDUCED BY ROTATION

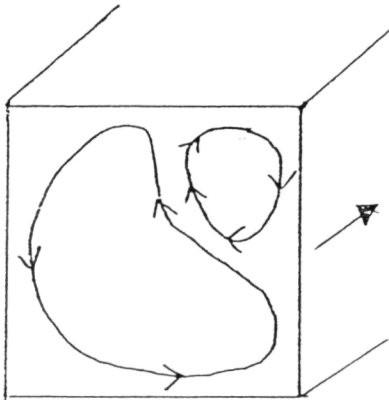

FIGURE 8.3 - DOUBLE VORTEX INDUCED BY THE TRIPS AND ROTATION

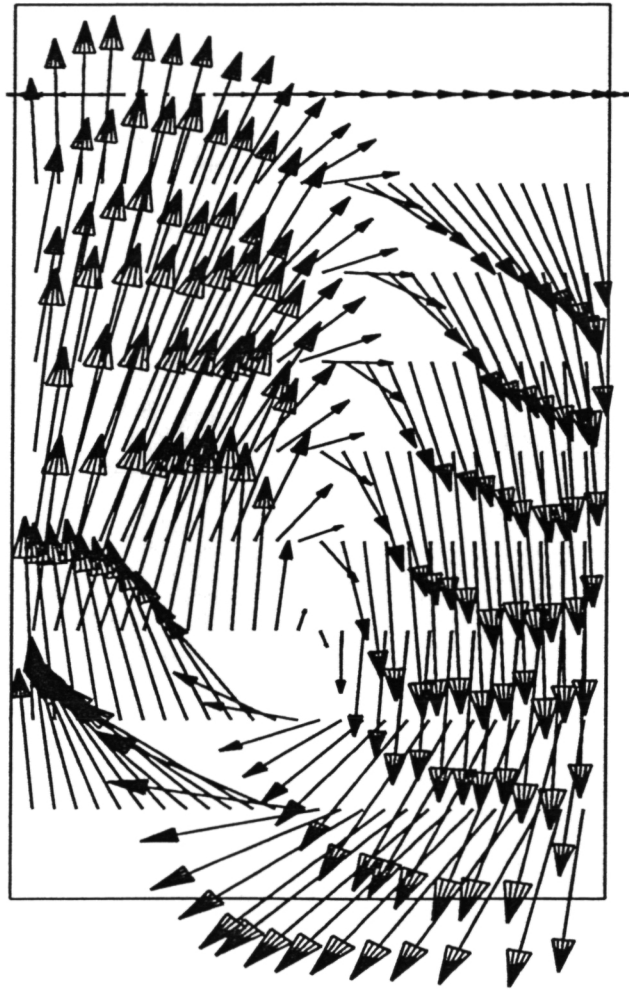

FIGURE 9

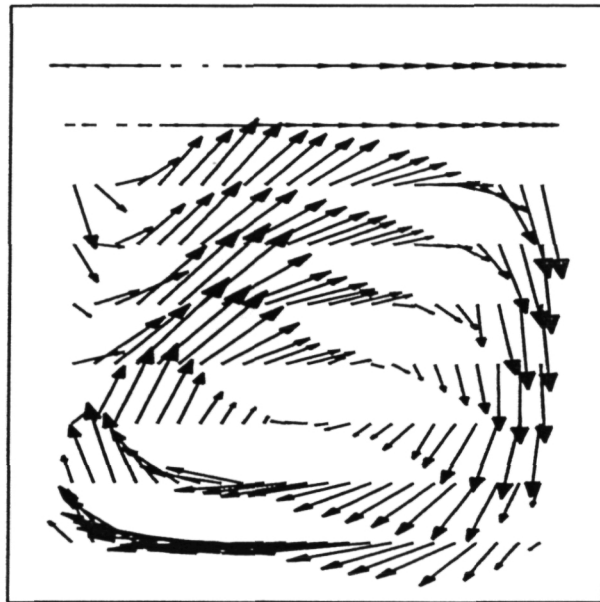

FIGURE 10

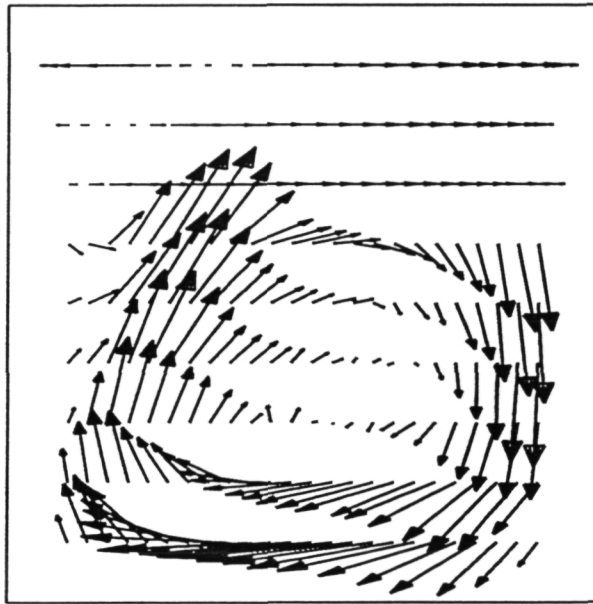

FIGURE 11

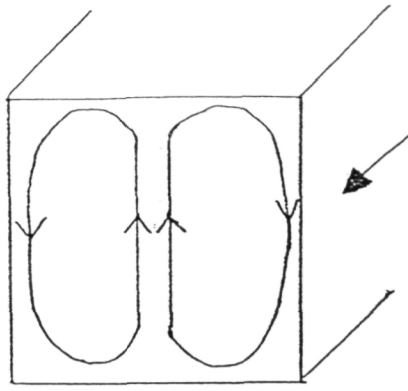

FIGURE 12.1 - DOUBLE VORTEX INDUCED BY THE TRIPS

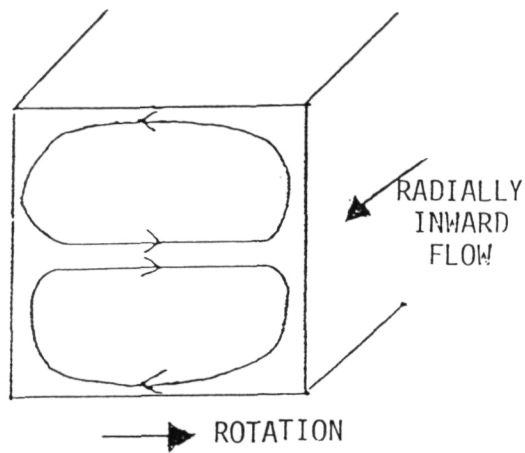

FIGURE 12.2 - DOUBLE VORTEX INDUCED BY ROTATION

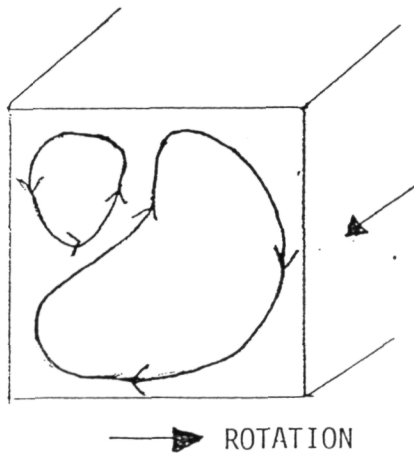

FIGURE 12.3 - DOUBLE VORTEX INDUCED BY THE TRIPS AND ROTATION

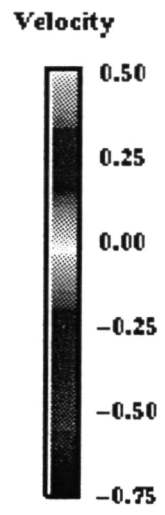

FIGURE 13

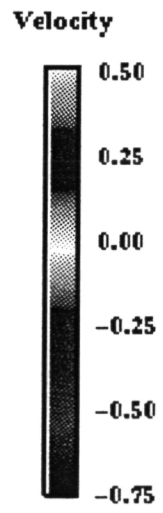

FIGURE 14

This is a monthly progress report in support of Contract NAS3-27378, "Flow in Serpentine Coolant Passages with Trip Strips" as per Pratt & Whitney Subcontract Proposal 94-3651.

Reporting Period September 1, 1995 to September 30, 1995 by G. D. Steuber

Requirements

The objective of this subcontract is to perform numerical simulations and compare them to the experimental data obtained by the contractor, Scientific Research Associates (SRA) under Task 4 of NAS3-27378. In addition, calculations shall be run to simulate selected heat transfer data (acquired by the United Technologies Research Center (UTRC) under Task 30 of NAS3-26618).

Pratt and Whitney (P&W) shall apply its Navier-Stokes code (NASTAR) to a rotating cooling passage with skewed trip strips assuming periodically fully developed flow. Grid sensitivity studies will be performed utilizing a two-equation k-epsilon turbulence model with two near wall treatments (wall functions and a two-layer wall integration model). Based on the results of the grid sensitivity study, (and the number of model passages jointly defined by P&W, UTRC, SRA and the NASA contract monitor), simulations will be performed for both a stationary and rotating duct with incompressible and compressible fluid.

Progress

As part of a separately funded P&W effort, NASTAR is being modified to allow for periodically fully developed, "conveyor-belt" type inlet and exit plane boundary conditions. This capability, which reduces computational grid requirements for streamwise "repeating" geometric patterns, is currently scheduled to be used for the grid sensitivity study of this contract. Problems in applying the conveyor-belt logic to the skewed trip strip geometry were surfaced and were being worked during this reporting period.

As part of the contract activities, efforts were focused on interpolating the SRA u,v,w and rms velocity field data into the NASTAR initialization procedure in order to run the channel simulation cases. Once this is complete, the next step is to then begin the four scheduled channel simulations.