



AIAA 95-2982
Flight Demonstration of Laser Diode Initiated Ordnance

C. Boucher
The Ensign-Bickford Company
Simsbury, CT

N. Schulze
NASA Headquarters
Washington, DC

(NASA-TM-111092) FLIGHT
DEMONSTRATION OF LASER DIODE
INITIATED ORDNANCE (NASA) 16 p

N96-12344

Unclass

G3/28 0071551

31st AIAA/ASME/SAE/ASEE
Joint Propulsion Conference and Exhibit
July 10-12, 1995/San Diego, CA

FLIGHT DEMONSTRATION OF LASER DIODE INITIATED ORDNANCE

Craig J. Boucher
The Ensign-Bickford Company
Simsbury, CT

Norman R. Schulze
NASA Headquarters
Washington, DC

ABSTRACT

Abstract - A program has been initiated by NASA Headquarters to validate laser initiated ordnance in flight applications. The primary program goal is to bring together a team of government and industry members to develop a laser initiated ordnance system having the test and analysis pedigree to be flown on launch vehicles. The culmination of this effort was a flight of the Pegasus® launch vehicle which had two fin rockets initiated by this laser system. In addition, a laser initiated squib was fired into a pressure bomb during thrusting flight.

The complete laser ordnance system comprising a laser diode firing unit, fiber optic cable assembly, laser initiated detonator, and laser initiated squib was designed and built by The Ensign-Bickford Company. The hardware was tested to the requirements of the Pegasus® launch vehicle and integrated onto the vehicle by The Ensign-Bickford Company and Orbital Sciences Corporation. Discussions include initial program concept, contract implementation, team member responsibilities, analyses results, vehicle integration, safing architecture, ordnance interfaces, mission timeline and telemetry data. A complete system description, summary of the analyses, the qualification test results, and the results of the flight are included.

PROGRAM OUTLINE

The use of laser diode initiated ordnance technology has been limited by the lack of flight experience. A "Catch 22" situation existed where vehicle designers were reluctant to fly a new technology until it had some flight experience. This situation was recognized by NASA Headquarters and a program was initiated to obtain the needed flight experience. This program, called the Laser Initiated Ordnance System Validation Program (LIOSVP), took the form of a NASA contract to The Ensign-Bickford Company to design, build, and test a Laser Diode Initiated Ordnance System

(LDIOS). The Ensign-Bickford Company executed a sub-contract to the Orbital Sciences Corporation to fly this system on the Pegasus® launch vehicle.

EXPERIMENT OBJECTIVES

The primary objectives of this program were as follows;

- 1) Design an LDIOS to initiate two of the nine fin rockets used to steer Pegasus® during the last part of stage 1 burn,
- 2) Qualify this system to the same environments as the mechanical safe and arm presently used for this task,
- 3) Support the design with appropriate safety analyses,
- 4) Integrate this system with the Pegasus® avionics, and
- 5) Fly the LDIOS on a Pegasus® mission.

A secondary objective was to initiate a laser initiated squib into a pressure bomb late in the stage 1 burn. A block diagram of the flight experiment can be seen in Figure 1.

LASER INITIATED ORDNANCE FLIGHT EXPERIMENT TEAM

The contracting method used for this program was a first-of-its-kind non-profit co-operative working agreement with a profit making company. Normally reserved for non-profit institutions such as universities, the co-operative working agreement was executed for a profit making company in support of NASA's continuing efforts to commercialize space technology (see reference 2 for detailed information). As stated, this was the bellwether contract of a new contracting method for NASA. This contracting method carried

specific limitations;

- 1) No products are to be delivered to NASA under this contract,
- 2) The vendor must accept no fee,
- 3) The government must provide significant contribution to the program.

The first two requirements are met in a straight forward manner. To meet the third requirement, NASA Headquarters created a laser ordnance team comprising members from NASA, DoD, DoE, and industry. Specifically, representatives from the following organizations were involved;

- NASA Headquarters
- NASA Goddard Space Flight Center
- NASA Johnson Space Center
- NASA Jet Propulsion Laboratory
- NASA Wallops Flight Facility
- The Aerospace Corporation
- Sandia National Laboratories
- Eastern Space & Missile Command Range Safety
- Western Space & Missile Command Range Safety
- Wallops Flight Facility Range Safety
- Martin Marietta Technologies Incorporated
- Orbital Sciences Corporation
- The Ensign-Bickford Company

Each team member was specifically selected for its expertise in laser initiated ordnance technology and/or applications and contributed to the program by providing technical support, guidance, or analyses specific to this system.

MISSION PROFILE

Pegasus® (see Figure 4) is a three stage solid propellant launch vehicle air launched from a specially modified L-1011 aircraft. Designed to put small payloads into earth orbit, the Pegasus® is dropped from the L-1011 at T+0 seconds from an altitude of approximately 40,000 ft. At T+5 seconds the stage 1 motor is ignited. At T+67 seconds, during the last portion of the stage 1 motor burn, nine fin rockets (3 in each fin) are ignited to provide enhanced attitude control as the atmosphere thins (see Figure 11). In the normal system, all nine fin rockets are initiated by an electro-mechanical safe/arm as shown in Figure 2. Two fin rockets, one in each horizontal fin, were chosen as the events to be initiated by the laser system since ignition failure or inadvertent initiation would not jeopardize the mission. A strain gage on each fin rocket motor was used as a telemetry indication of successful initiation. Similar to the

existing system which uses a mechanical safe/arm, detonating cord, through bulkhead initiator ordnance train (see Figure 2), the laser initiation train comprised a laser initiated detonator, manifold, detonating cord and through bulkhead initiator (see Figure 3). As shown in Figure 3, the fin rocket initiation system was re-arranged to allow two fin rockets to be initiated from the laser system while the remaining seven are initiated by the normal system (the laser ordnance portion of the fin rocket system is shown in bold).

Under command of the vehicle avionics, the Laser Diode Firing Unit (LDFU) will send a 10ms pulse of laser light down the Energy Transfer System (ETS) and into the Laser Initiated Detonator (LID). The LID is initiated by the laser light and produces an explosive output which is coupled to two Flexible Confined Detonating Cord Assemblies (FCDCAs) using a manifold. The detonation signal propagates along each FCDCAs at approximately 23,000 feet/second and initiates a Through Bulkhead Initiator (TBI) in each fin rocket motor. Each TBI, in turn, produces a flame and pressure output which ignites the fin rocket motors.

A second laser initiated event, a laser initiated squib fired into a pressure bomb, was included to provide flight experience of a laser initiated squib device. The squib was to be initiated just prior to stage 1 burnout, to provide maximum environmental exposure, with pressure telemetry data provided on a wideband analog telemetry channel.

SYSTEM DESIGN

As stated, the system was designed to initiate two fin rocket motors and a squib into a pressure bomb under control of the Pegasus® avionics. A block diagram of the experiment is shown in Figure 1 and 9. The LDFU received power from the avionics power bus and laser battery. A separate battery was used to provide an isolated power source for the LDFU laser power so as not to violate the Pegasus® single point grounding. The arm command was issued from the aft skirt Pyro Driver Unit and the fire commands originated in the Flight Computer. Telemetry was provided for the LDFU status signals, strain gages on the fin rocket motors, and pressure from the pressure bomb. The LID transitioned to two Flexible Confined Detonating Cord Assemblies (FCDCAs) using a manifold. Each FCDCAs connected to a Through Bulkhead Initiator (TBI) which directly initiated the fin rocket motors. The LIS was installed directly into a 10cc closed pressure bomb with a pressure transducer to measure the resulting output pressure during functioning of the LIS. The pressure transducer output was connected directly into the

telemetry multiplexer.

The system designed for this mission comprised a Laser Diode Firing Unit shown in Figure 5, fiber optic Energy Transfer System also shown in Figure 5, Laser Initiated Detonator shown in Figure 6, and Laser Initiated Squib shown in Figure 7. The LDFU, ETS, and LIS designs were based on a similar firing unit designed and qualified for the Naval Research Laboratory Advanced Release Techniques program¹. The LID was designed with an output which duplicates a standard detonating cord output. The manifold and FCDCA can be seen in Figure 10. The TBI is not shown. The manifold is a standard manifold design modified to accept a laser detonator input. The FCDCA and TBIs were the component normally flown on the Pegasus[®] and were not unique to this experiment.

Laser Diode Firing Unit The LDFU is a two channel all solid state safe and arm which utilizes transistor switches as inhibits. The internal safing architecture for the LDFU, shown in Figure 8, comprises a master arming switch which arms both outputs and individual fire switches, one for each output. Two power inputs are provided, one for power to the laser diodes and one for the control and monitoring circuits. — Monitoring is provided for each inhibit.

Energy Transfer System The ETS is a two channel fiber optic cable assembly which transmits the laser light from the LDFU to the LID or LIS. The optical cable, terminated in a MIL-C-38999 connector at the LDFU and ST connectors and the LID and LIS, comprises a radiation resistant multi mode optical fiber covered by multiple layers of Tefzel[®] and Kevlar[®] for strength and abrasion resistance.

Laser Initiated Detonator The LID is an all secondary explosive Deflagration to Detonation Transition (DDT) detonator. The HMX (high meltpoint explosive) first mix is directly ignited by the laser light. The HMX transitions from deflagration to detonation in a specially designed column. The column detonation output transitions to a 1 grain HNS (hexanitrostilbene) output cup which duplicates the output of standard detonating cord.

Laser Initiated Squib The LIS is a form, fit, and functional replacement for a NASA Standard Initiator (NSI). The laser light directly ignites the zirconium potassium perchlorate ($ZrKClO_4$, the same material used in the NSI) and produces the same pressure-time output as the NSI.

Manifold The manifold is a precision machined block which properly aligns the LID output and FCDCA

inputs in order to obtain reliable detonation transfer while containing all gasses, shrapnel, and debris.

Flexible Confined Detonating Cord The FCDCA comprises a precision core load of 2.7 grain/foot of HNS surrounded by protective layers of Tefzel[®], braided Kevlar[®], and braided steel. The input and output (which are interchangeable) comprise a welded and crimped booster assembly containing a 1 grain HNS cup identical to the LID. The FCDCA provides reliable transfer of a detonation signal while containing all gasses, shrapnel, and debris.

Through Bulkhead Initiator The TBI transitions the detonation output of an FCDCA to a pyrotechnic output capable of igniting a solid propellant rocket motor. The TBI also provides a post-function pressure seal that withstands the temperature and pressure of the solid rocket motor throughout the motor burn.

SAFING ARCHITECTURE

The internal safing architecture of the LDFU, shown in Figure 8, comprises a master arming switch and individual fire switches for each channel. Two separate power inputs provide separate power for the laser diodes (Laser Power) and for control and monitoring (Monitor Power). Control is provided through discrete 28V commands, 5VDC telemetry outputs are provided for arm/safe status and fire switch status, and analog telemetry outputs are provided for both Laser and Monitor Power. The LDFU fits into the system architecture as shown in Figure 9. Monitor Power is provided from the Pegasus[®] avionics power bus while Laser Power is provided by a separate battery installed specifically for this experiment. The LDFU design is based on a system designed and built for a satellite and has a common internal ground for Laser and Monitor Power. This required the use of a separate battery to eliminate a ground loop between the Pegasus[®] avionics power bus and transient power bus (which would have been used for the Laser Power source had the LDFU grounds been isolated). External to the LDFU, a safe/arm plug provides a positive interruption of the Laser Power input to the LDFU. The safe/arm plug was used for local control during ordnance hookup and to prevent the LDFU from depleting the battery during launch delays of a day or more.

During the flight, the LDFU is armed from the pyro driver unit following release of Pegasus[®] from the L-1011. The fire commands were provided by the flight computer at the desired times to initiate the fin rockets and pressure bomb squib. The telemetry points were connected directly to the telemetry

multiplexer to provide status of the LDFU during the mission. Neither the flight computer nor the pyro driver unit received status information from the LDFU.

HARDWARE LOCATIONS

All the hardware was located in the Pegasus® aft skirt which surrounds the stage 1 nozzle. Figure 10 shows the locations of the flight hardware taken prior to the mating of the aft skirt to the vehicle. In the orientation shown, the nozzle would point up (the access door can also be seen on the aft right hand side of Pegasus® in Figure 11). The LDFU was mounted directly to the aft skirt support ring with no vibration isolators. The ETS was secured to the skin using standard cable fasteners. The ETS connects to the LDFU connector on the left side as shown in Figure 10. The electrical cables, not shown, connect to the two connectors on the right side of the LDFU. The LID manifold replaced an existing manifold used to cross strap the outputs of the electro-mechanical safe/arm. In this photo, the LID manifold can be seen secured with a "C" clamp prior to final mounting. The LID, not shown, is installed into manifold LID port which is covered by a plug. The FCDCAs, which run from the manifold to the fin rocket TBIs, can be seen exiting the manifold and running along the skin to the fin clearance hole. The pressure bomb was located on a support strut. The LIS, not shown, was mounted directly into pressure bomb where the protective cover is shown. The pressure transducer is also mounted directly into the pressure bomb but cannot be seen in this view.

HARDWARE MANUFACTURE

The flight and qualification LDFUs, ETSs, LIDs, LISs, manifolds, and pressure bomb were built by the Ensign-Bickford Company specifically for this mission. The FCDCAs and TBIs were also manufactured by the Ensign-Bickford Company and are standard items flown on each Pegasus® vehicle.

ACCEPTANCE TESTING

Two LDFUs and two ETSs, one each for flight and one each for qualification, were built and subjected to acceptance testing. The LDFU and ETS acceptance testing was performed as defined in Table I. This testing comprised thermal cycle and random vibration. During the thermal cycle testing, each channel of the LDFU was fired and the laser power measured at the end of each thermal dwell. In addition, power-off cold soak, power off hot soak, and testing at low, nominal, and high line voltages were also included. During the random vibration testing, each channel of the LDFU was also fired and the power measured. Acceptance

testing of the LDFU and ETS was completed with no difficulties.

Thirty LIDs and thirty LISs were built and subjected to 100% inspection and non-destructive test as defined in Table II. These tests are the normal manufacturing tests performed for most ordnance products with the addition of optical loss measurements.

Since the manifold was an existing qualified design with only dimensional modifications the acceptance testing limited to dimensional testing on each unit and a functional test. The functional test verified proper transfer from the LID to two FCDCAs at 25°C, +74°C, and -54°C temperatures.

The pressure bomb was dimensionally inspected then subjected to hydrostatic testing at 3000 PSI for 5 minutes. Calibration shots were fired into the pressure bomb to validate the pressure bomb configuration as compared to the NASA Standard Initiator pressure bomb.

QUALIFICATION TESTING

Following successful completion of the acceptance testing qualification testing was performed. The qualification program was executed in two parts; component testing and system testing.

Component qualification testing The LDFU and ETS were subjected to the component qualification testing shown in Table I. This testing comprised thermal cycle, random vibration, and thermal vacuum. Similar to the acceptance testing, each channel of the LDFU was tested during each thermal extreme during thermal cycle and thermal vacuum testing. Also, each channel of the LDFU was fired during the random vibration exposure. Due to a limitation of the vibration table, the desired qualification level of 24.6gRMS (6dB above the acceptance level) was not achieved. In order not to impact the flight schedule, it was decided to qualify the LDFU to 3dB above the acceptance level, then repeat the 24.6gRMS test during qualification testing of the same system for a flight termination demonstration mission aboard a Nike-Orion sounding rocket². The qualification program for the Nike-Orion program is summarized in Table III. All the qualification testing for both the Pegasus® and Nike-Orion missions was completed prior to either flight. The thermal vacuum testing was performed in the same manner as the thermal cycle with each channel of the LDFU tested at the end of each thermal extreme dwell. A special bulkhead plate was designed to allow the optical fibers to be run through the side of the vacuum chamber.

The LID and LIS were subjected to the component qualification testing shown in Table II. Following exposure to the stated thermal cycle and random vibration environments, the LIDs and LISs were subjected to helium leak then functioned at hot, cold, and ambient temperatures. During this functional test, the LID function time and output dent into a steel block was measured. The LIS function time, peak pressure, and pressure-time curve was recorded.

System qualification testing Following successful completion of the component qualification testing, the system qualification testing shown in Table IV was performed. This testing comprised tests which verified the interfaces from the LDFU to the flight computer and pyro driver unit. Also included was a full scale ground test where the system was assembled in the flight configuration using engineering units for the flight computer, pyro driver unit, and telemetry system and functioned in a simulated flight.

The thermal extremes test was performed to verify the interfaces between the LDFU, Flight Computer, and Pyro Driver Unit over the vehicle operating temperature range. During this test, the LDFU was inadvertently soaked at -67°C due to an equipment malfunction. The problem was corrected and the LDFU was soaked for the defined time at -54°C before the test was successfully executed.

The full scale system test was a final validation of the system interfaces before the hardware was installed on the vehicle and to provide a baseline of the pressure bomb telemetry trace. The system was tested using the flight mission data load for the flight computer which determines when each output of the LDFU is commanded to fire. The test was performed with no difficulties. The LDFU successfully initiated the LID upon command from the flight computer. The LID initiated two FCDCA's whose outputs were protected by a containment cap with accelerometers attached for data recording. The LIS was successfully initiated with the pressure-time curve recorded at the output of the pressure transducer and at the output of the telemetry multiplexer. This provided a basis of comparison between the transducer trace and the telemetry trace to be recorded on the ground since the telemetry multiplexer filters the transducer signal using a 2kHz low pass filter.

SYSTEM ANALYSES

In support of this program an experiment safety analysis was performed by Orbital Sciences Corporation to determine the effect of the experiment on the mission. The conclusion of this analysis was that the experiment posed no threat to mission

success due to inadvertent initiation or failure of initiation. A safety assessment report was performed by NASA Johnson Space Center which included a component level Failure Modes, Effects, and Criticality Analysis (FMECA). The FMECA revealed no single component failures which would cause an inadvertent output. The Aerospace Corporation performed a sneak circuit analysis and general circuit analysis which revealed two potential component overstress conditions which could occur from a voltage transient on the Laser Power bus which was not simultaneously present on the Monitor Power bus. While this should not happen on this experiment since the Laser Power comes from a battery, the hardware had not yet been fabricated and an easy circuit modification was incorporated which eliminated the potential overstress.

A reliability prediction was performed which showed the calculated probability of mission success (successful function of both the LID and LIS) was in excess of 0.995. A bent pin analysis for the LDFU connectors was also performed to determine if any critical failure modes existed which would cause inadvertent initiation or mission failure. No critical bent pin failure modes were found.

VEHICLE INTEGRATION

The flight hardware (less the ordnance) was installed onto the aft skirt prior to mating the aft skirt to the vehicle as shown in Figure 10. Following the aft skirt mate, the LDFU was tested as part of the normal flight simulation testing. During flight simulation testing, the Pegasus® avionics are "flown" by providing simulated flight dynamics data and the response of the avionics is monitored. During this testing, the ordnance firing circuits are connected to electrical pulse catchers which monitor the level and time of the ordnance firing circuit outputs. For the laser system, optical pulse catchers were designed and built which would provide the same information. These optical pulse catchers were used during each flight simulation test (the test is repeated at various points during the vehicle build). The optical pulse catchers were also used to assure that no transient laser pulses occurred during power switching (both on and off). All the vehicle integration tests were completed successfully.

ORDNANCE CONNECTION/CLOSEOUT

Following the combined systems test, which occurs after the Pegasus® is mated to the L-1011 carrier vehicle, the ordnance was installed. The installation was made through the safe/arm access door (see Figure 11) with the Pegasus® located on the hot pad (a section of the taxiway adjacent to the air strip). This installation was performed about 24 hours prior

to launch. The optical pulse catchers were used to perform a stray light test similar to a stray voltage test immediately prior to connection of the LID and LIS. Once the ordnance was installed, the safe/arm plug was installed and the experiment was ready for flight.

FLIGHT MISSION

The first launch attempt was scrubbed due to poor weather. A one day re-cycle was planned so the ordnance was left installed and the safe/arm plug was removed. The safe/arm plug was re-installed the next day just before take-off of the L-1011. The second launch attempt was scrubbed during captive carry prior to drop due to an insulation problem with the vehicle. After the L-1011 landed it was determined that the repair would take a few days so the LID and LIS were left installed but were disconnected from the ETS. Following the insulation repair, the LID and LIS were reconnected to the ETS about 24 hours prior to launch. The Pegasus® vehicle was successfully launched on April 3, 1995 from Vandenberg AFB. At T+5.0 seconds following release from the L-1011, the stage 1 motor was ignited. At T+67 seconds, the flight computer commanded the LDFU to fire the fin rockets. Successful fin rocket ignition was observed on the chase plane video and confirmed by the strain gage telemetry. The LDFU also successfully fired the LIS into the pressure bomb at T+79 seconds with the vehicle at 175,000 ft altitude travelling at 7500 ft/sec. The pressure bomb data was not immediately available (it was recorded for post mission playback) but was confirmed the following day. Following the squib initiation at T+79 seconds, the experiment was complete. The Pegasus® vehicle successfully completed its mission by placing three satellites into their proper orbits.

TELEMETRY DATA

Fin rocket telemetry The telemetry for the port center fin rocket motor is shown in Figure 12. The telemetry channel dropped out from T+22 seconds to T+49 seconds but was fully functional during the fin rocket ignition and shows a normal fin rocket ignition strain gage signature at T+67 seconds. The telemetry for the starboard center fin rocket strain gage also showed successful initiation.

Pressure bomb telemetry The pressure bomb telemetry is shown in Figure 13. The data shows the fast rise and slow decay characteristic of a LIS with the peak pressure meeting the specified performance requirements. The baseline data curve labelled "lab" was the data taken directly from the transducer during the system qualification test. The flight plot is within specification but on the low side of nominal.

Qualification testing of the laser initiated squibs for this program showed only minor performance degradation at cold temperature (the aft skirt was at approximately -32°C during flight). The low measured peak pressure was most likely caused by performance degradation of the pressure transducer at cold temperature rather than actual pressure performance of the LIS. While the transducer was operated within its rated temperature range, it was not discovered until after the mission that the stated accuracy was for a limited temperature range. The performance of the pressure transducer was not characterized at cold temperature prior to the mission.

CONCLUSION

This program successfully completed all the stated mission objectives;

- 1) a laser diode initiated ordnance system was designed which initiated two of the nine fin rockets used to steer Pegasus® during the last part of stage 1 burn,
- 2) this system was successfully qualified to the same environments as the mechanical safe and arm presently used for this task,
- 3) the system was determined to have the safety features necessary for the Pegasus® flight,
- 4) the system was successfully integrated with the Pegasus® avionics, and
- 5) the system flew a 100% successful mission on the Pegasus® launch vehicle.

This program successfully demonstrated that a laser diode initiated ordnance system can be designed without mechanical barriers for space launch vehicle applications, qualified to a traditional qualification program, and integrated onto existing launch vehicle platforms.

References

¹ *Laser Ordnance System for NRL's ARTS Program*, B. Purdy, M. Fratta, C. Boucher, AIAA 93-2361

² *Flight Demonstration of Flight Termination System and Solid Rocket Motor Ignition Using Semiconductor Laser Initiated Ordnance* N. Schulze, B. Maxfield, C. Boucher, AIAA 95-2980

TEST	ACCEPTANCE LEVELS	QUALIFICATION LEVELS
THERMAL CYCLE	-24°C/+61°C, 8 cycles	-34°C/+71°C, 32 cycles
RANDOM VIBRATION	10.5gRMS, 75 sec., 3 axes	15.5gRMS, 225 sec., 3 axis
THERMAL VACUUM	-	-54°C/+71°C, 3 cycles @10 ⁻⁵ torr

Table I - LDFU/ETS Component Test Matrix

TEST	100% INSPECTION/TEST	QUALIFICATION LEVELS
OPTICAL LOSS	< 1.0dB	-
HELIUM LEAK	10 ⁻⁶ cc/sec He @1 atm	-
RADIOGRAPHIC INSPECTION	X-RAY/N-RAY	-
THERMAL CYCLE	-	-54°C/+74°C, 8 cycles
RANDOM VIBRATION	-	24.6gRMS, 225 sec., 3 axes
HELIUM LEAK	-	10 ⁻⁶ cc/sec He @1 atm
FUNCTION	-	1/3 lot sample @-54°C 1/3 lot sample @25°C 1/3 lot sample @74°C
POST FUNCTION INTEGRITY	-	15,000 PSI

Table II - LID/LIS Component Test Matrix

TEST	QUALIFICATION TEST LEVELS
THERMAL CYCLE	-24°C/+61°C, 8 CYCLES
SINE SWEEP VIBRATION	7.3 in/s 5-89Hz, 10.5g 89-800Hz, 15.0g 800-2000Hz
RANDOM VIBRATION	20gRMS, 20 SEC/AXIS, 3 AXES 24.6gRMS, 225 SEC/AXIS, 3 AXES
ACCELERATION	60g, 1 MIN, 3 AXES
SHOCK	20g HALF SINE, 11ms, 1 SHOCK EACH DIR. OF EACH AXIS 80g HALF SINE, 3ms, 1 SHOCK EACH DIR. OF EACH AXIS

Table III - Nike-Orion Qualification Test Matrix

TEST	QUALIFICATION TEST LEVELS
THERMAL EXTREMES	-54°C/+25°C/+71°C test with Flight Computer and Pyro Driver Unit
FULL SCALE FUNCTIONAL	+25°C, test with Flight Computer, Pyro Driver Unit, Telemetry Multiplexer, Laser Initiated Detonator, and Laser Initiated Squib

Table IV - System Level Qualification Test

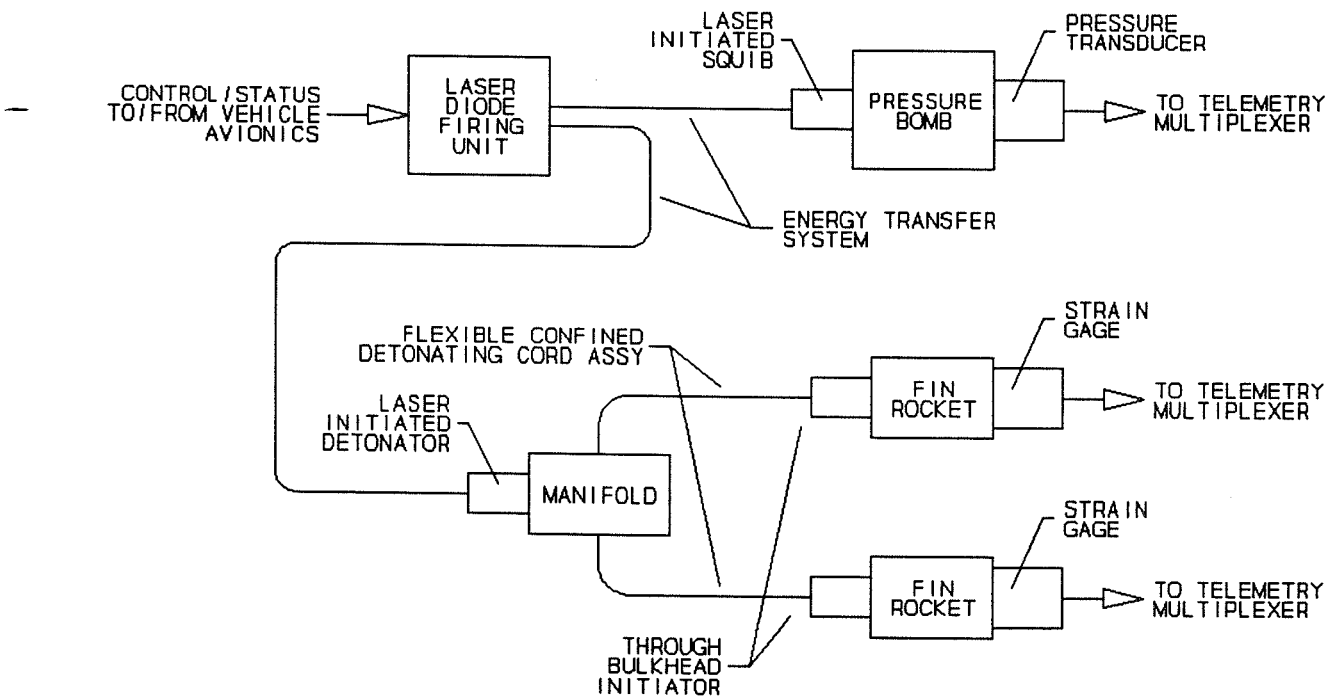

Figure 1 - Flight Experiment Block Diagram

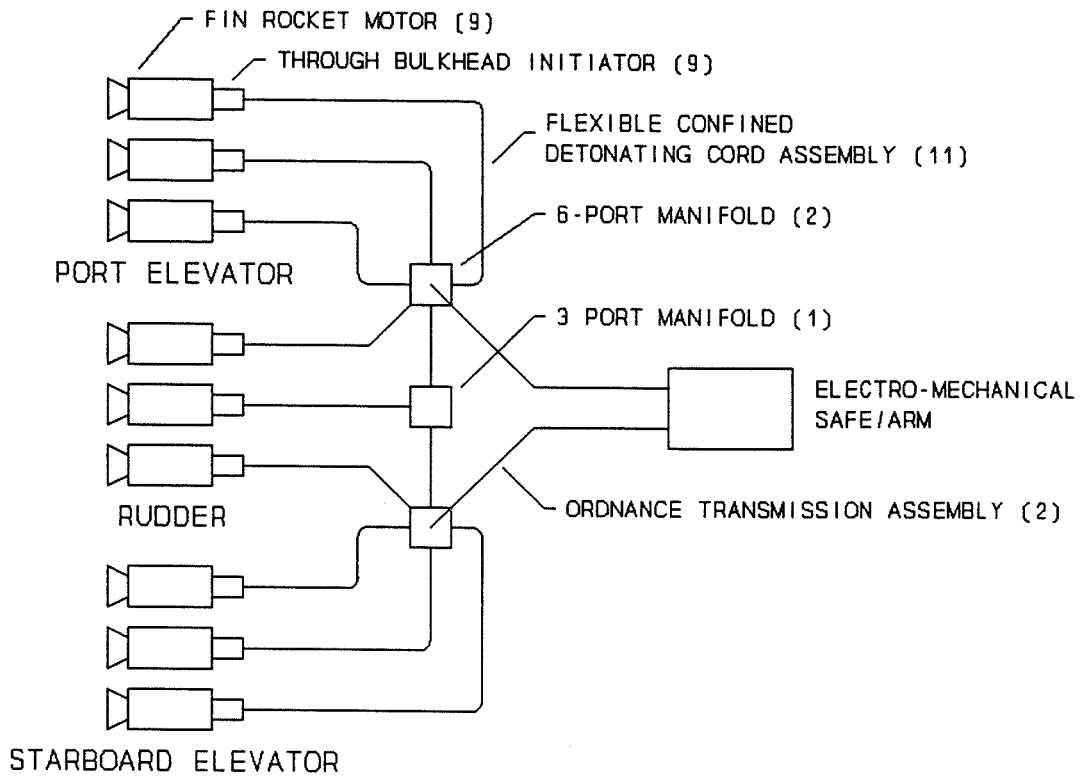

Figure 2 - Pegasus® Fin Rocket Layout

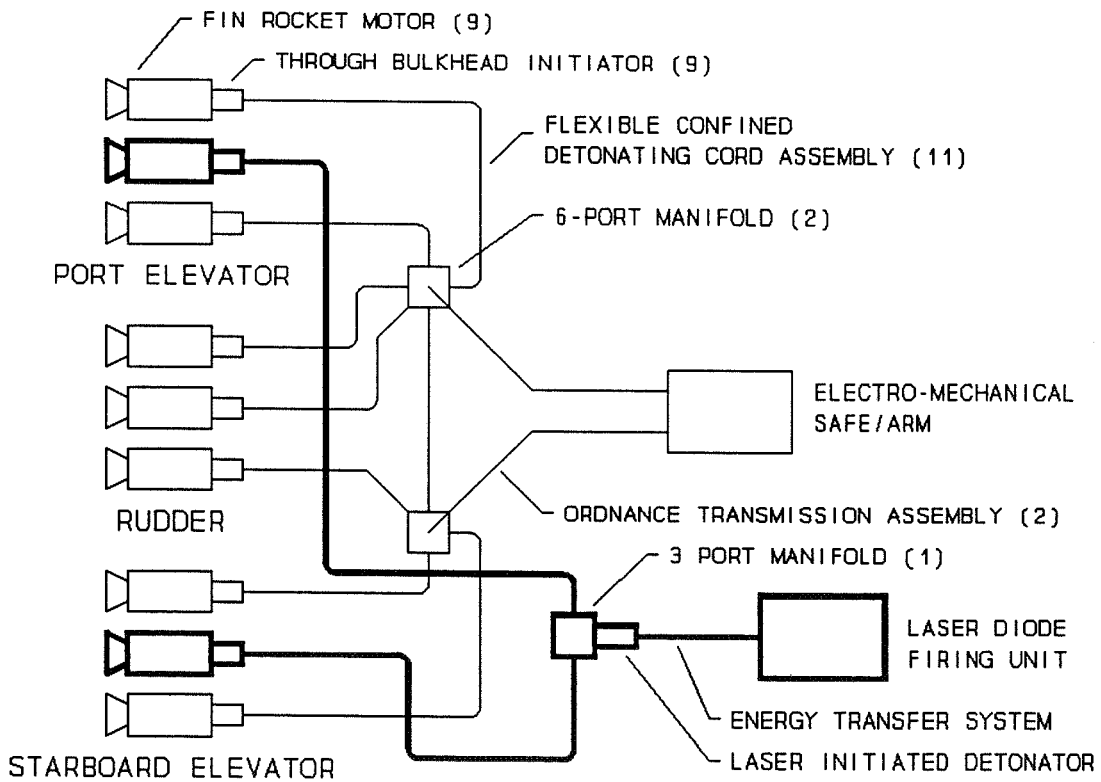

Figure 3 - Experiment Fin Rocket Layout

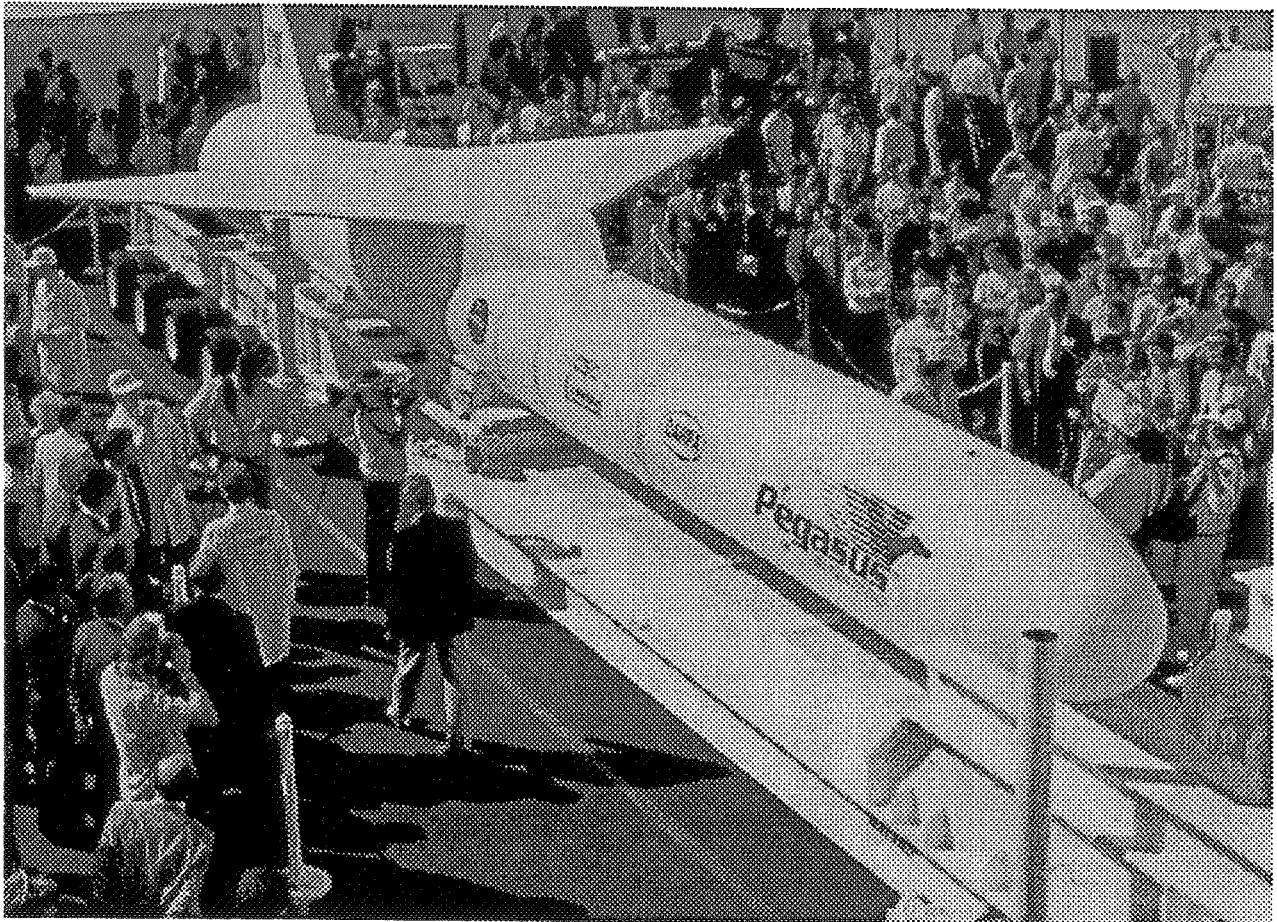

Figure 4 - Pegasus® Launch Vehicle

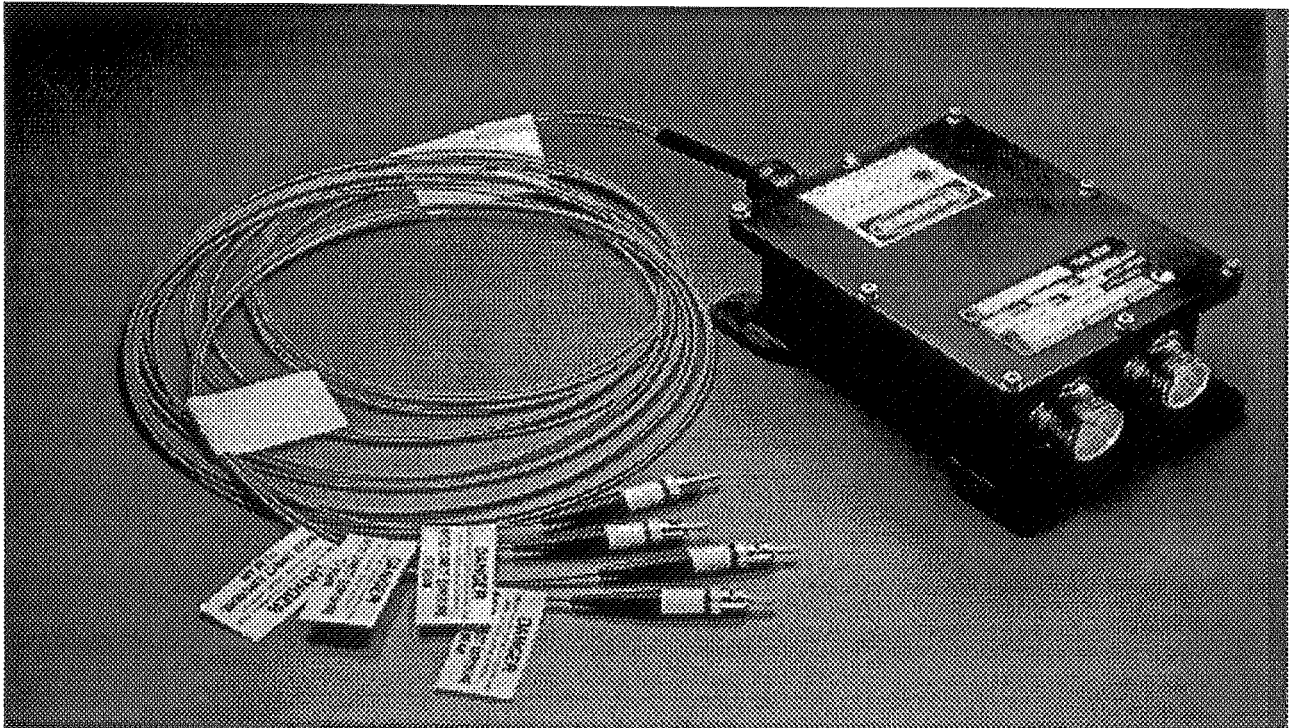

Figure 5 - Laser Diode Firing Unit

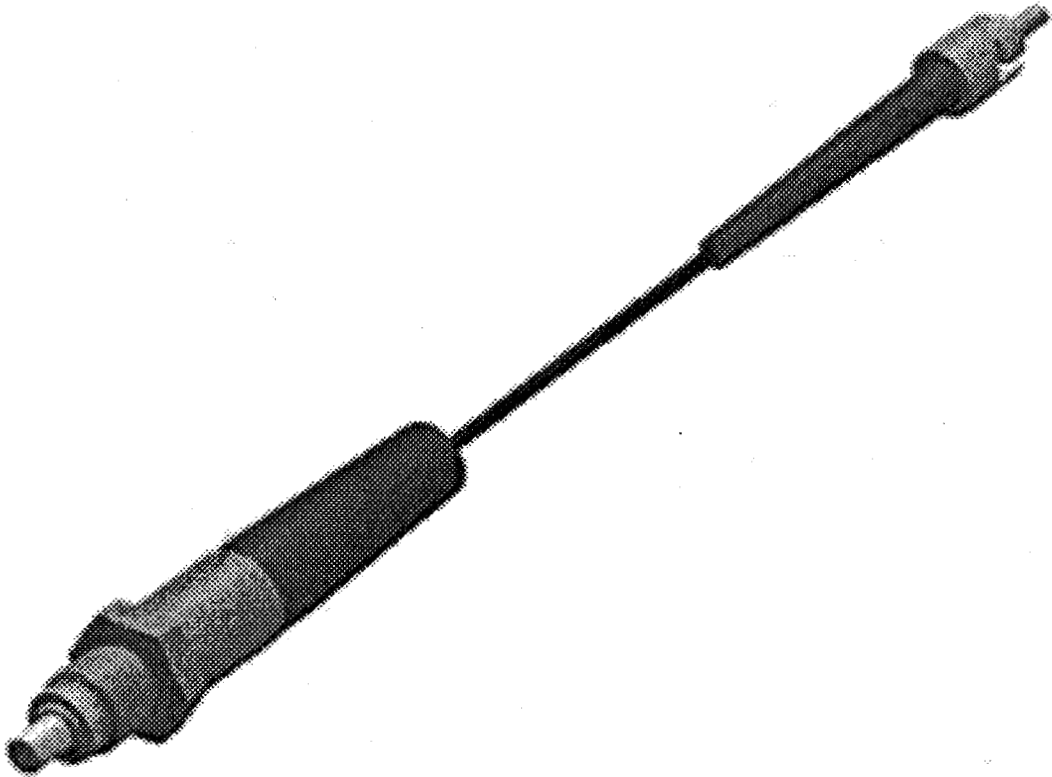

Figure 6 - Laser Initiated Detonator

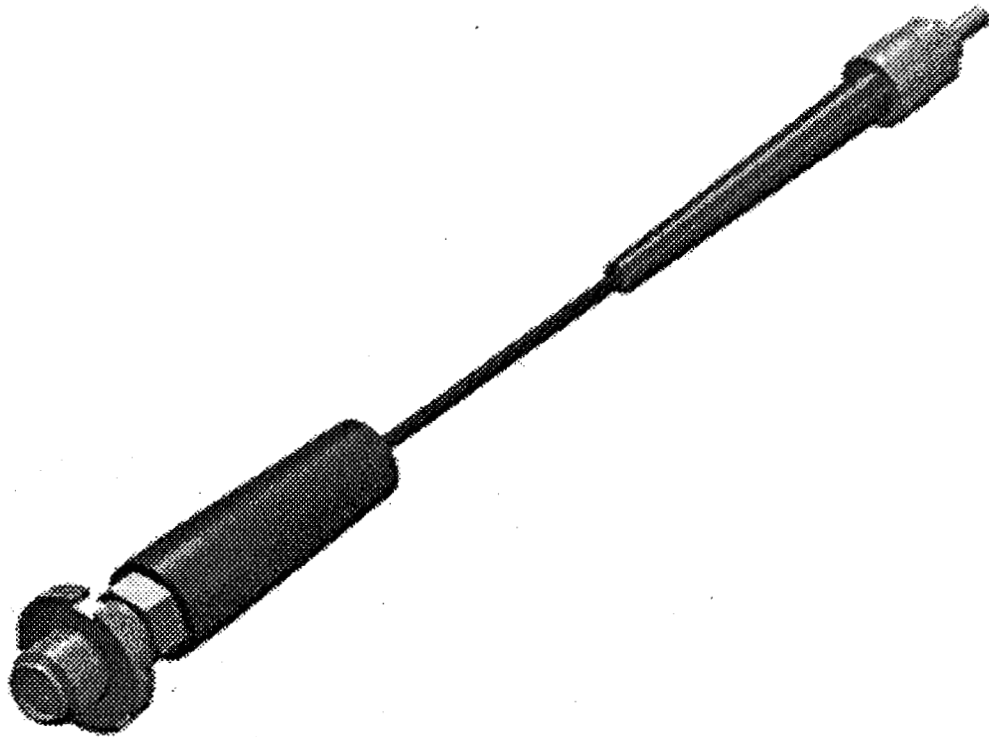

Figure 7 - Laser Initiated Squib

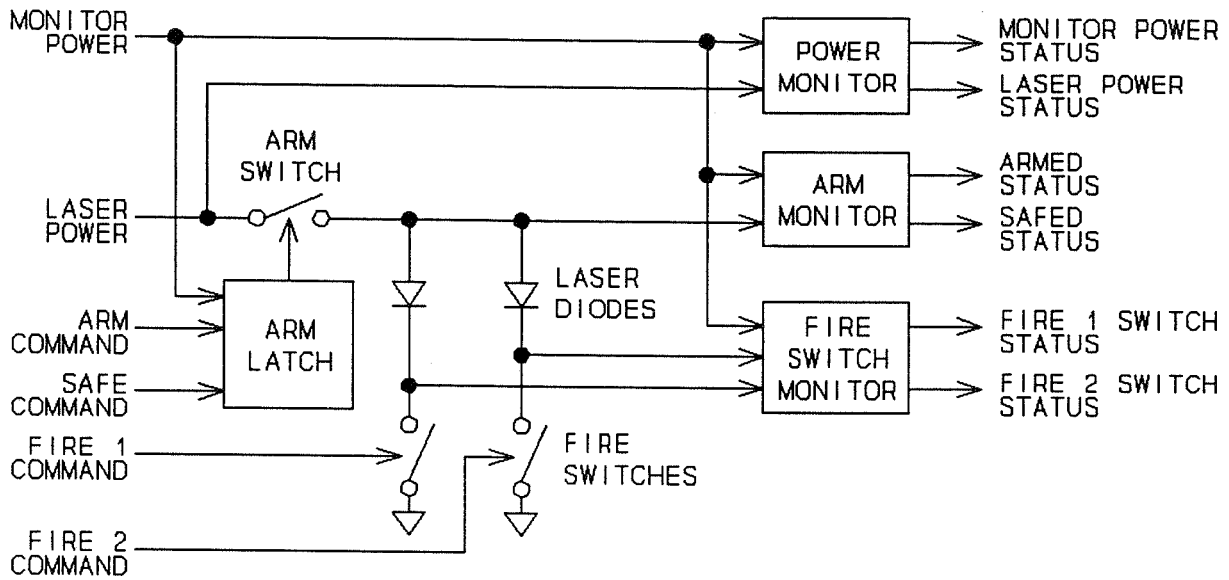

Figure 8 - LDFU Safing Architecture

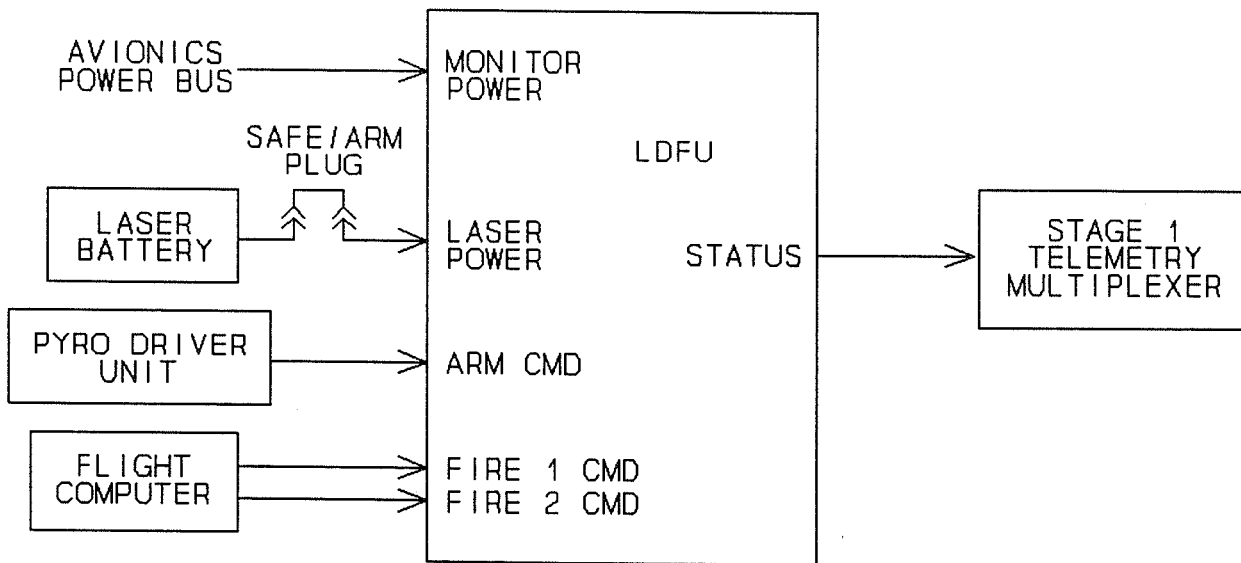

Figure 9 - Pegasus® Avionics Block Diagram

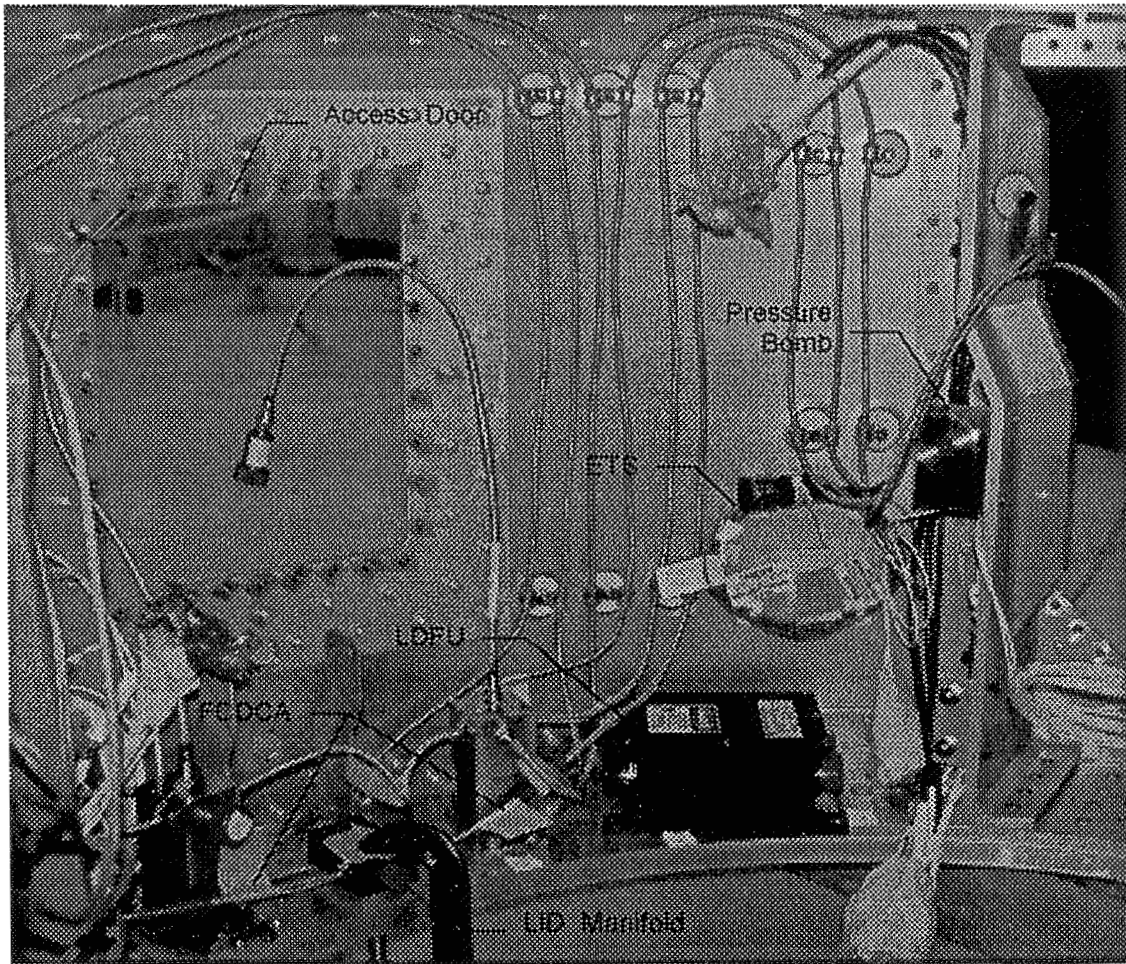

Figure 10 - Pegasus® Aft Skirt (prior to stage 1 mate)

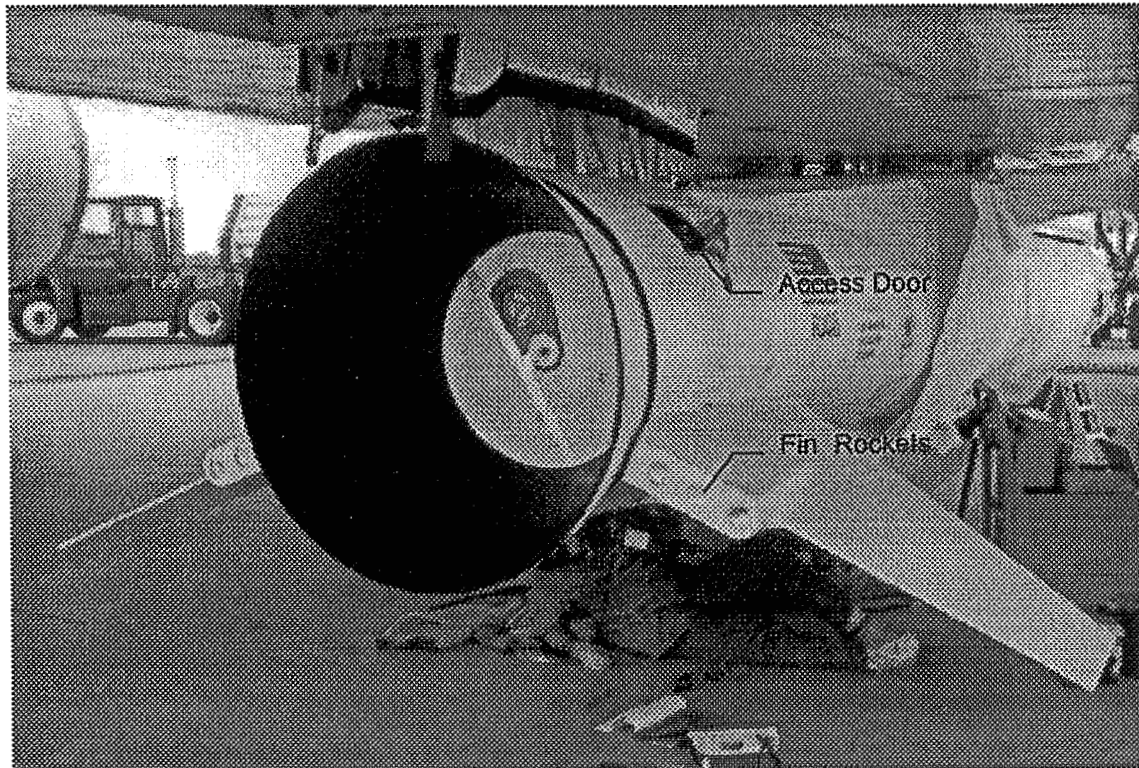

Figure 11 - Pegasus® Aft View

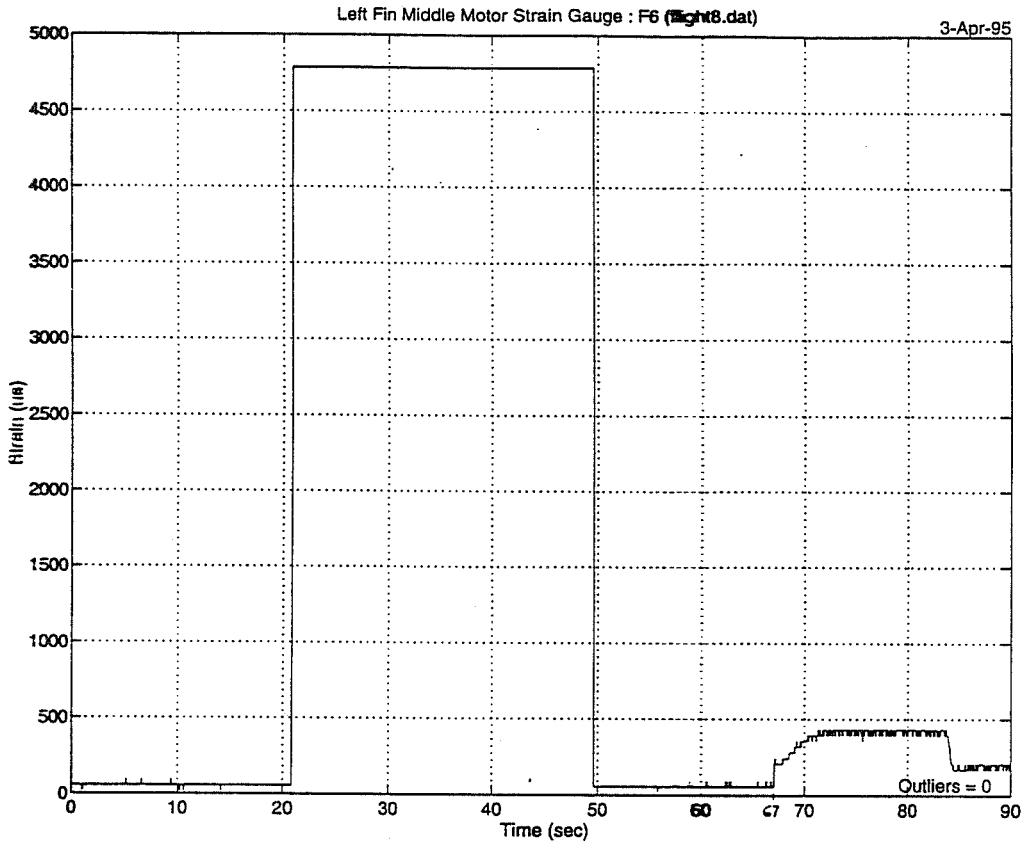

Figure 12 - Fin Rocket Strain Gauge Telemetry

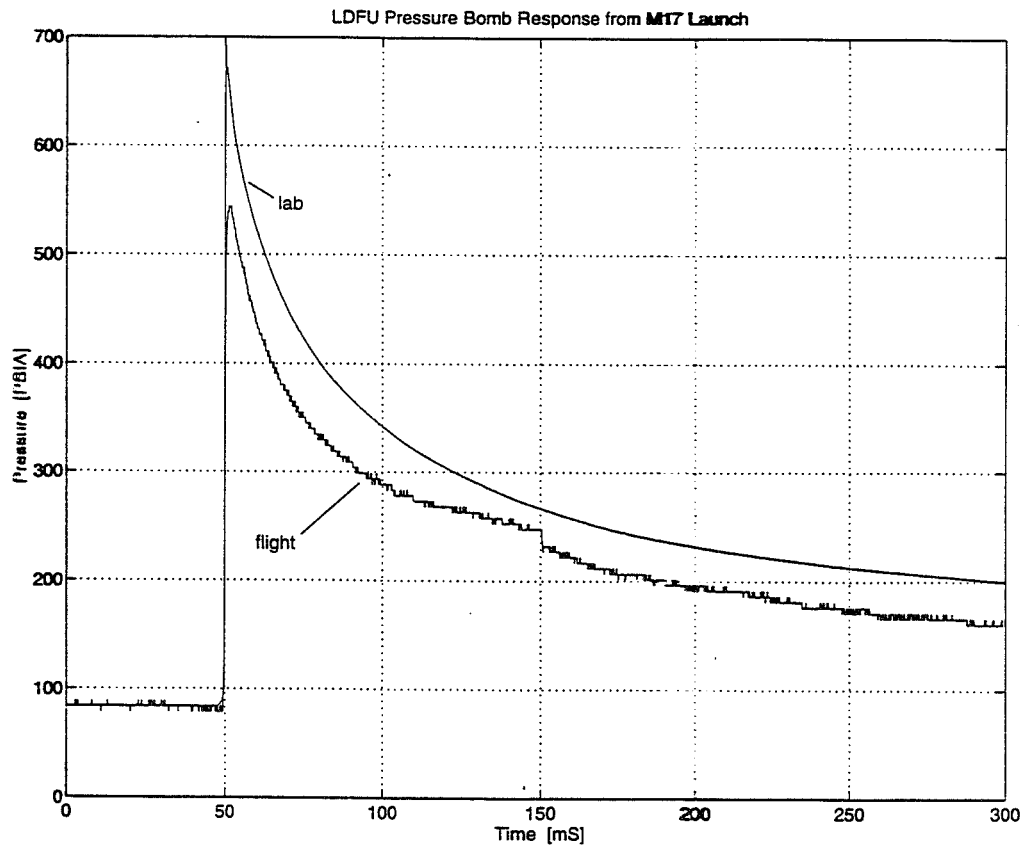

Figure 13 - Pressure Bomb Telemetry

REPORT DOCUMENTATION PAGE

Form Approved
OMB No. 0704-0188

Public reporting burden for this collection of information is estimated to average 1 hour per response, including the time for reviewing instructions, searching existing data sources, gathering and maintaining the data needed, and completing and reviewing the collection of information. Send comments regarding this burden estimate or any other aspect of this collection of information, including suggestions for reducing this burden, to Washington Headquarters Services, Directorate for Information Operations and Reports, 1215 Jefferson Davis Highway, Suite 1204, Arlington, VA 22202-4302, and to the Office of Management and Budget, Paperwork Reduction Project (0704-0188), Washington, DC 20503.

1. AGENCY USE ONLY (Leave blank)		2. REPORT DATE July 10-12, 1995	3. REPORT TYPE AND DATES COVERED Technical Memo, 1993-95	
4. TITLE AND SUBTITLE Flight Demonstration of Laser Diode Initiated Ordnance, AIAA 95-2982			5. FUNDING NUMBERS <i>IN-28- Overhead 5122 P-16</i>	
6. AUTHOR(S) C. Boucher, N. Schulze			8. PERFORMING ORGANIZATION REPORT NUMBER	
7. PERFORMING ORGANIZATION NAME(S) AND ADDRESS(ES) Office of Space Access and Technology Code XS NASA Headquarters Washington, D.C. 20546			10. SPONSORING/MONITORING AGENCY REPORT NUMBER	
9. SPONSORING/MONITORING AGENCY NAME(S) AND ADDRESS(ES) Office of Space Access and Technology Code XS NASA Headquarters Washington, D.C. 20546			11. SUPPLEMENTARY NOTES Prepared for the 31 st AIAA/ASME/SEA/ASEE Joint Propulsion Conference and Exhibit, July 10-12, 1995, San Diego, CA	
12a. DISTRIBUTION/AVAILABILITY STATEMENT Unlimited			12b. DISTRIBUTION CODE	
13. ABSTRACT (Maximum 200 words) A program has been initiated by NASA Headquarters to validate laser initiated ordnance in flight applications. The primary program goal is to bring together a team of government and industry members to develop a laser initiated ordnance system having the test and analysis pedigree to be flown on launch vehicles. The culmination of this effort was a flight of the Pegasus® launch vehicle which had two fin rockets initiated by this laser system. In addition, a laser initiated ordnance squib was fired into a pressure bomb during thrusting flight. The complete ordnance system comprising a laser diode firing unit, fiber optic cable assembly, laser initiated detonator, and laser initiated squib was designed and built by The Ensign Bickford Company. The hardware was tested to the requirements of the Pegasus® launch vehicle and integrated into the vehicle by The Ensign Bickford Company and the Orbital Sciences Corporation. Discussions include initial program concept, contract implementation, team member responsibilities, analysis results, vehicle integration, safing architecture, ordnance interfaces, mission timeline and telemetry data. A complete system description, summary of the analyses, the qualification test results, and the results of flight are included.				
14. SUBJECT TERMS Pyrotechnics, lasers, laser ordnance, reliability, safety, programs, solid rocket motors, applied technology, solid state safe and arm, Shuttle payload, unmanned launch vehicle system, sounding rocket			15. NUMBER OF PAGES	
			16. PRICE CODE	
17. SECURITY CLASSIFICATION OF REPORT Unclassified	18. SECURITY CLASSIFICATION OF THIS PAGE Unclassified	19. SECURITY CLASSIFICATION OF ABSTRACT Unclassified	20. LIMITATION OF ABSTRACT	

