

1N-02

5907

p. 22

NASA Technical Memorandum 4722

Design and Development of an F/A-18 Inlet Distortion Rake: A Cost and Time Saving Solution

Andrew J. Yuhas, Ronald J. Ray, Richard R. Burley,
William G. Steenken, Leon Lechtenberg, and Don Thornton

October 1995



(NASA-TM-4722) DESIGN AND
DEVELOPMENT OF AN F/A-18 INLET
DISTORTION RAKE: A COST AND TIME
SAVING SOLUTION (NASA, Dryden
Flight Research Center) 22 p

N96-14003

Unclass

H1/02 0075098

Design and Development of an F/A-18 Inlet Distortion Rake: A Cost and Time Saving Solution

Andrew J. Yuhas
PRC Inc.
Edwards, California

Ronald J. Ray
Dryden Flight Research Center
Edwards, California

Richard R. Burley
NASA Lewis Research Center
Cleveland, Ohio

William G. Steenken, Leon Lechtenberg
and Don Thornton
General Electric Aircraft Engines
Evendale, Ohio



National Aeronautics and
Space Administration
Office of Management
Scientific and Technical
Information Program

1995

DESIGN AND DEVELOPMENT OF AN F/A-18 INLET DISTORTION RAKE: A COST AND TIME SAVING SOLUTION

Andrew J. Yuhas*
PRC Inc.
Edwards, California

Ronald J. Ray**
NASA Dryden Flight Research Center
Edwards, California

Richard R. Burley†
NASA Lewis Research Center
Cleveland, Ohio

William G. Steenken,†† Leon Lechtenberg‡, and Don Thornton‡‡
General Electric Aircraft Engines
Evendale, Ohio

ABSTRACT

An innovative inlet total-pressure-distortion measurement rake has been designed and developed for the F/A-18 A/B/C/D aircraft inlet. The design was conceived by NASA and General Electric Aircraft Engines personnel. This rake has been flight qualified and flown in the F/A-18 High Alpha Research Vehicle at NASA Dryden Flight Research Center, Edwards, California. The eight-legged, one-piece, wagon wheel design of the rake was developed at a reduced cost and offered reduced installation time compared to traditional designs. The rake features 40 dual-measurement ports for low- and high-frequency pressure measurements with the high-frequency transducer mounted at the port. This high-frequency transducer offers direct absolute pressure measurements from low to high frequencies of interest, thereby allowing the rake to be used during highly dynamic aircraft maneuvers. Outstanding structural characteristics are inherent to the design through its construction and use of lightweight materials.

NOMENCLATURE

Acronyms

AIP aerodynamic interface plane
AIR Aerospace Information Report
ALF aft looking forward
AOA angle of attack, deg

ARP Aerospace Recommended Practice
ac alternating current
CFD computational fluid dynamics
DFRC Dryden Flight Research Center,
Edwards, California
F/A fighter-attack aircraft
FOD foreign object damage
GE General Electric
GEAE General Electric Aircraft Engines,
Evendale, Ohio
g inertial force expressed in multiples of
gravity
HARV High Alpha Research Vehicle
HATP High Alpha Technology Program
ID inside diameter
LeRC Lewis Research Center, Cleveland,
Ohio
M Mach number
NASA National Aeronautics and Space
Administration
NASTRAN NASA Structural Analysis, a finite
element modeling program
OD outside diameter
PSI Pressure Systems Incorporated,
Hampton, Virginia

PSIPP	pounds force per square inch, peak to peak
RTV	room temperature vulcanizing
SAE	Society of Automotive Engineers
X	experimental aircraft

Symbols

σ	standard deviation
----------	--------------------

INTRODUCTION

Designing, developing, and installing an inlet total-pressure-distortion rake can be expensive and time consuming. Figure 1 shows the F/A-18 High Alpha Research Vehicle (HARV) being flown at NASA Dryden Flight Research Center (DFRC), Edwards, California. The HARV inlet research program goals required a low-cost, short-installation-time, and low-maintenance solution to meet the need for a total-pressure inlet-distortion measurement system. The HARV inlet research program evaluates the inlet characteristics of high-performance aircraft during

stabilized and highly dynamic maneuvers at high angles of attack.

Traditional inlet rake systems typically use eight-legged, duct-mounted cantilevered designs, such as those used on the developmental F/A-18A¹ or inlet guide vane leading-edge designs.² These designs have commonly required extensive modifications to the aircraft or the engine. In particular, the cantilevered system, with its individual rake leg designs and installations, can be costly, because of separate rake leg development and testing. In addition, this system can be time consuming because of increased structural modifications of the aircraft and flight qualification testing.

Figure 2 shows an inlet rake which was developed by the NASA Lewis Research Center (LeRC), Cleveland, Ohio, and DFRC. This rake was based on an innovative design concept conceived by NASA and General Electric Aircraft Engines (GEAE), (Evendale, Ohio). This approach connects all of the rake legs together at the hub to form a one-piece, wagon wheel design. This design simplifies rake installation and aircraft modification requirements, thus greatly reducing cost and weight. The rake, designed and fabricated by GEAE,

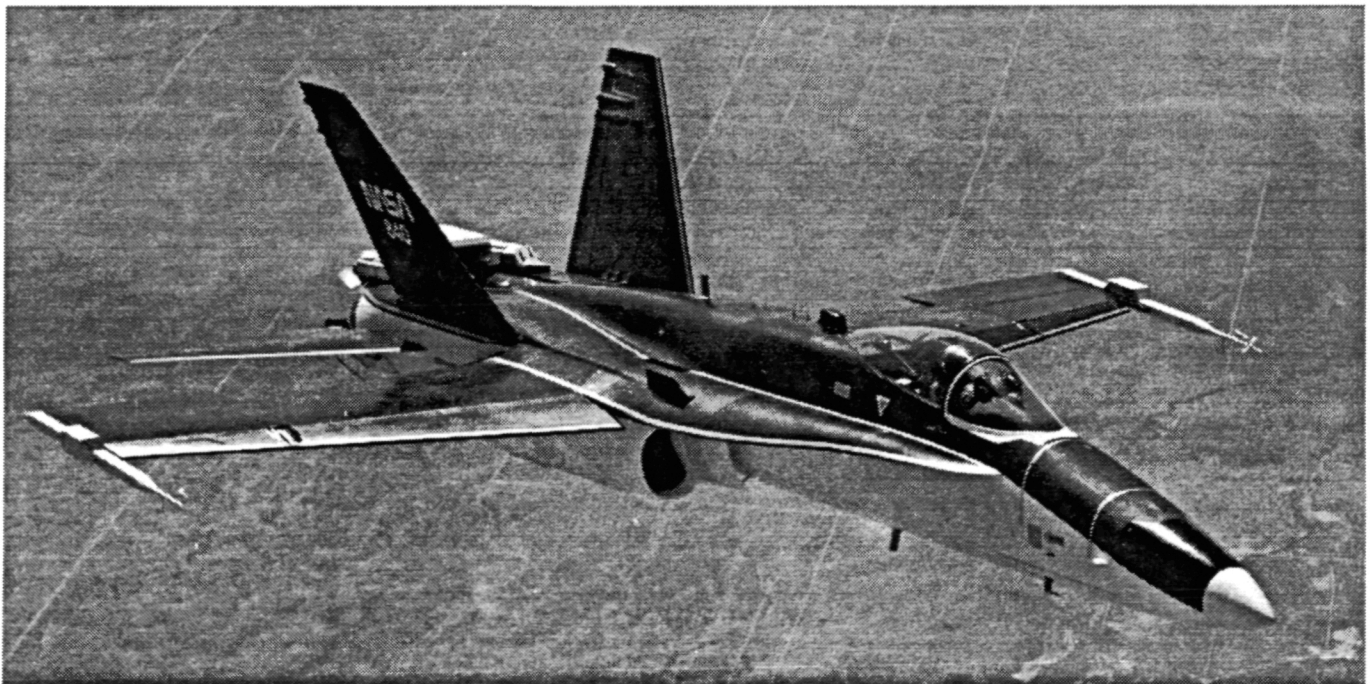

EC 91 495-15

Figure 1. NASA F/A-18 HARV aircraft (preproduction aircraft number 6 modified with multiaxis thrust vectoring paddles).

has passed the needed flight qualification requirements and has been flown on the HARV.

This paper describes the design, fabrication, installation, and qualification testing of the HARV inlet rake system. Comparisons of cost and installation time between this design and a previous design are made. The paper also details the design requirements and pressure transducer selection. All stages of flight qualification testing, from laboratory to flight test, are described.

Use of tradenames or names of manufacturers in this paper does not constitute an official endorsement of such products or manufacturers, either expressed or implied, by the National Aeronautics and Space Administration.

INLET RAKE SYSTEM REQUIREMENTS

When considering an inlet rake design for use on the F/A-18 HARV flight program, the basic requirements were first established. The most important requirement was to provide as much commonality as practical with the planned HARV inlet wind tunnel test at the LeRC and with previous F/A-18 inlet testing. Commonality considerations with past and present testing included

but were not limited to instrumentation setup, rake positioning, and probe configuration. The design also had to allow accurate data measurements to be gathered to meet all of the HARV inlet research objectives. This requirement primarily concerned instrumentation selection. In addition, following established industry guidelines wherever possible was desired. Considerations of cost and installation time are always important factors that ultimately constrained the design requirements.

Commonality

Inlet instrumentation was required on the HARV to correlate flight data with and verify test results from the planned 9- by 15-ft wind tunnel tests scheduled at the LeRC as part of the High Alpha Technology Program (HATP) inlet research program. In that aspect, the HARV instrumentation was developed to emulate the wind tunnel set, limited primarily by the cost and complexity of modifying the full-scale vehicle.

Having commonality between the current flight test rake and previous F/A-18 flight test rakes was also desirable. In the mid-1970's, the U.S. Navy along with industry partners, McDonnell Douglas Aerospace

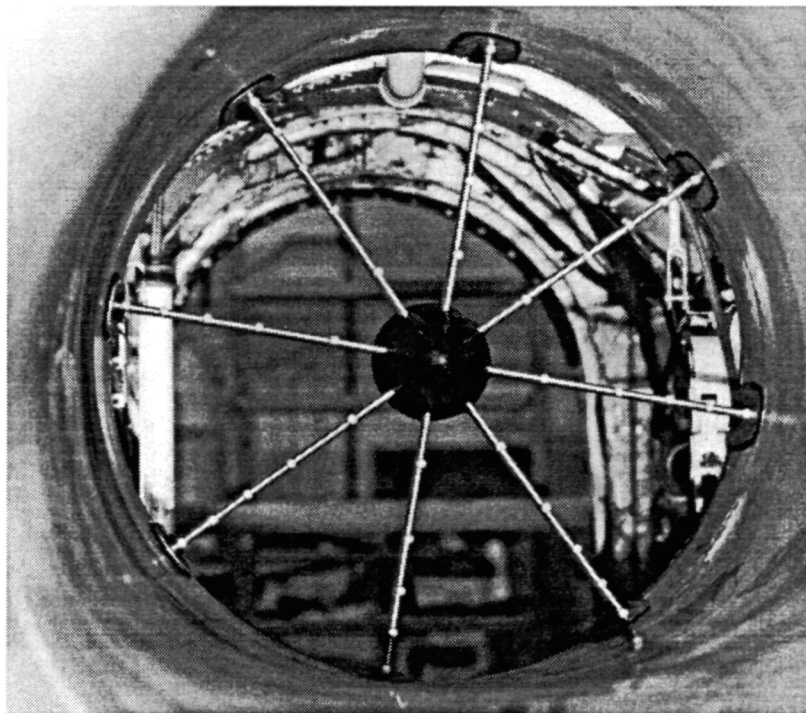

Figure 2. NASA and GEAE inlet pressure distortion rake mounted in HARV right inlet.

(St. Louis, Missouri), Northrop Aircraft Division (Newbury Park, California), and GEAE conducted an inlet evaluation on the second preproduction F/A-18A. The original inlet rake design consisted of eight independent, cantilevered rakes, each spaced equiangularly, having five measurement ports per rake located on the centroids of five equal areas.¹ Each rake was mounted to various structural members behind the inlet duct wall. Because of the forces and moments acting on each cantilevered rake, special attention was given to the structural design and buildup. To meet the complex inlet rake structural requirements, the bulkhead on aircraft number 2 was specifically designed to accommodate the inlet rake-mounting requirements. The cost and time required for this modification was obviously significant. Figure 3 shows the original rake installed in aircraft number 2. This original inlet rake design generally followed the instrumentation guidelines established by industry.^{2,3}

Technical Guidelines

An Aerospace Recommended Practice titled *Gas Turbine Engine Inlet Flow Distortion Guidelines*, ARP 1420, was established by the Society of Automotive

Engineers (SAE) in 1978 to ensure a consistent approach to the development of the inlet instrumentation configuration and to provide a proven and consistent method of data analysis.³ The SAE document recommends that the instrumentation and analysis methods be agreed upon among the involved parties and remain invariant throughout the propulsion system life cycle for all testing. This general approach was followed for the design and manufacture of the HARV inlet rake described here. In 1983, SAE issued a more comprehensive report, *Inlet Total-Pressure-Distortion Considerations for Gas-Turbine Engines*, AIR 1419, that provides more detailed information.²

The SAE established the "aerodynamic interface plane" (AIP) as the location of the instrumentation plane used to define inlet distortion and performance. In general, the guide recommended that the AIP should be located in a circular duct as close to the engine face as practical. The engine face is defined by the leading edge of the most upstream engine strut, vane, or blade row. To be consistent with past F/A-18 testing, the HARV AIP was required to be 4 in. in front of the engine bullet nose. The standard also established a typical 40-port rake array for distribution of the total pressure ports at the AIP. This array consists of eight

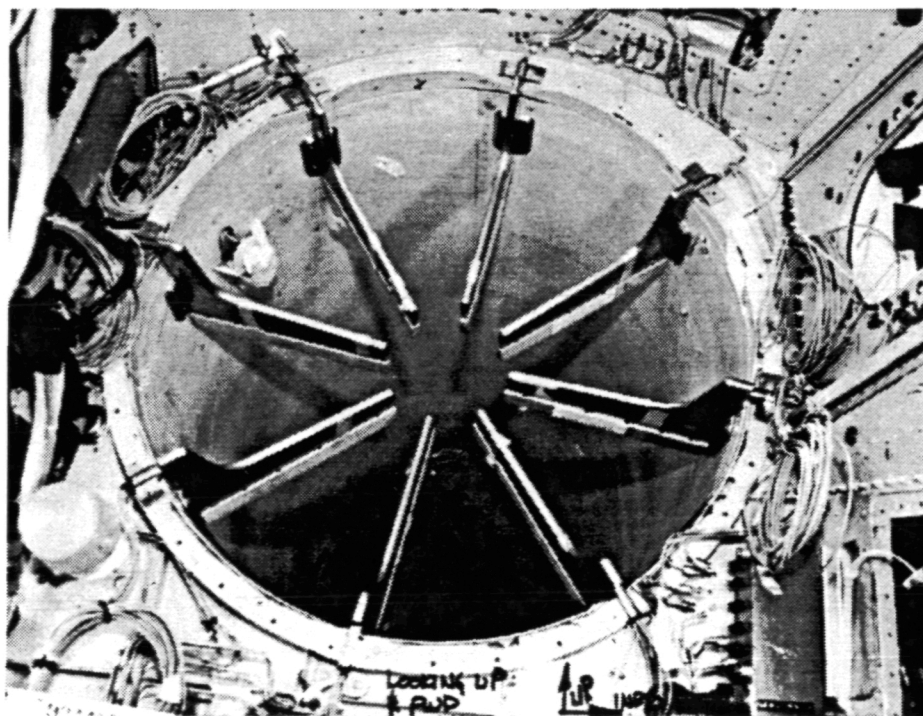

EC 91 220-2

Figure 3. Preproduction F/A-18A aircraft number 2 cantilevered inlet rake system.

equiangularly spaced rakes with five ports per rake located at the centroids of equal areas. The original F/A-18 rake (fig. 3) followed this configuration and was clocked (rotated clockwise aft looking forward (ALF)) approximately 9° . Clocking the rake is often required because of structure installation considerations. The HARV inlet flight test program goal was to meet this arrangement. Because the original F/A-18A rake was installed in the left inlet, the HARV rake, to be installed in the right inlet, was required to be clocked counterclockwise ALF approximately 9° . This configuration would make the installation equivalent because of symmetry.

HARV Inlet Research Objectives

Another consideration necessary for the design of the inlet rake was its intended use during the HARV inlet research flight test. The primary objectives of the research were as follows:

1. Determine whether highly dynamic aircraft maneuvers result in a significant increase in inlet pressure distortion levels compared to corresponding steady-flight conditions.
2. Determine whether sources other than spatial time-variant distortion lead to engine aerodynamic instabilities during aircraft departures.
3. Assess predicted inlet distortion from computational fluid dynamics (CFD) as compared to flight test measured levels.

These objectives have the dual requirement for gathering accurate inlet measurements during stabilized and dynamic maneuvers, including aircraft departures. The instrumentation setup for dynamic maneuvers would require more attention than the setup for stabilized maneuvers.

Instrumentation

Inlet pressure distortion instrumentation typically has the requirement for accurately measuring pressure levels at high frequencies. This requirement is typically achieved by measuring the inlet characteristics with a dual-probe configuration using low- and high-frequency response sensors. The low-frequency response probe usually consists of pneumatic tubing routed through and beyond the rake where it is connected to a highly accurate transducer. This pressure

transducer can either be absolute or differential (with an accurate reference source). This response system measures an accurate absolute pressure level. The high-frequency response probe typically consists of a miniature transducer mounted at the AIP. This response system measures the time-dependent component of the pressure but, normally, not an accurate absolute pressure level.

The HARV research objectives required instrumentation to measure stabilized and dynamic maneuvers. The typical instrumentation setup described in the previous paragraph would not be adequate to meet the demanding requirement of measuring inlet characteristics during dynamic maneuvers without introducing a large amount of measurement uncertainty. The HARV requires a system which would minimize the effects of two known drawbacks of the typical instrumentation setup that affect the ability to measure an accurate pressure level during a dynamic maneuver: pneumatic lag and thermal zero shift. Pneumatic lag describes the condition where the pressure signal at the AIP is delayed in reference to time to the transducer at the end of the tubing and, therefore, affects low-frequency response accuracy. Thermal zero shift affects the ability of the low- and, especially, the high-frequency response transducer to accurately measure the pressure level at varying inlet temperature conditions. Thermal zero shift describes the calibration shift of the zero voltage condition experienced as a pressure-sensing element of the transducer varies with temperature. Thus, the requirement was to develop an instrumentation setup that would allow for accurate measurement of the pressure level and the time-dependent component of the pressure during highly dynamic maneuvers.

The requirements for pressure and temperature ranges were determined by the flight conditions where research testing would take place. The HARV research occurred between an altitude from 15,000 to 40,000 ft and below Mach 0.9 (fig. 4). The necessary instrumentation pressure range was determined to be 2 to 16 psia. The temperature was from 395 to 618 °R.

Other instrumentation considerations outlined by industry through the SAE³ include that "the frequency response characteristic of the probe and transducer combination should be determined with reference to system accuracy requirements." GEAE determined that the highest frequency of interest for the F404-GE-400 engine was 105 Hz. NASA chose to increase the highest frequency of interest to 250 Hz. Industry requirements for the highest frequency of interest vary. NASA

required the higher range to allow the HARV inlet research database to be used by all interested industry customers. The instrumentation accuracy requirement needed to meet or exceed the original F/A-18A flight test. This testing called for the following system accuracy as a percent of reading (2σ): 3.2 percent at 2 psia, 1.3 percent at 5 psia, and 1 percent at 32 psia.¹

A final requirement stated for the instrumentation was ease of maintainability. Transducers needed to be accessible without engine removal. The ability to replace the transducer without removing the engine was also desirable. Additionally, the transducer or probe configuration should provide the sensing element of the transducer with protection from foreign object damage (FOD).

Aerodynamic and Structural Requirements

Figure 4 shows the aerodynamic design flight envelope. This envelope coincides with the normal operating envelope of the HARV aircraft and was chosen to allow unrestricted flight with the inlet rake installed. Inlet research test points were primarily focused at the low-speed portion of the envelope between Mach 0.3 and Mach 0.4. The worse-case dynamic pressure condition was at a Mach 0.7 at sea level conditions where

the freestream total pressure was 20.4 psia, and the hot day total temperature was 618 °R.

Requirements for the inlet rake design included additional aerodynamic and structural considerations. Designing the rake legs and center hub with an aerodynamic shape that minimized airflow disturbance and with a blockage factor as small as possible was desirable. The HARV blockage goal was to be equal to or less than the previous F/A-18A inlet rake design, which had a flow blockage of less than 8 percent.¹ Structural requirements included meeting the worse-case pressure loads. These loads include an inlet hammer shock overpressure of 20 psi maximum caused by an engine surge. The HARV structural load limits with the thrust vectoring vanes installed are 5.4 normal *g* loads and 2.0 lateral *g* loads. Of particular concern was the requirement to meet dynamic structural requirements as outlined in DFRC document "Process Specification 21-2, Environmental Testing Electronic and Electromechanical Equipment."^{*} In particular, the rake had to be designed stiff enough so that it did not exceed stress limits at its predominant structural frequencies

^{*}NASA Dryden internal document, "Process Specification 21-2, Environmental Testing Electronic and Electromechanical Equipment." Original released on May, 1968 with current updates until Apr. 1989.

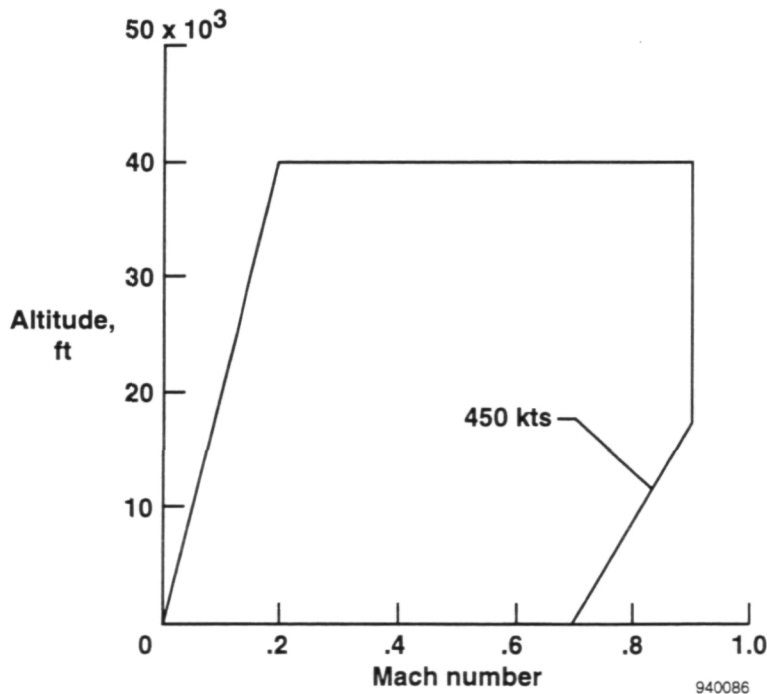

Figure 4. HARV inlet rake design flight envelope.

within the airframe and engine operating range. NASA also wanted a number of structural materials considered for the rake including composite materials. Use of composites could translate into a lighter, more aerodynamic design along with structural tailoring of the rake arms as compared to traditional designs.

Cost and Time Considerations

Two of the critical requirements that had to be met for the HARV inlet rake design were low cost and minimal installation time. An evaluation of the rake used in the original F/A-18 inlet compatibility program indicated costs in excess of \$1.5 million and installation time on the order of 1 year or more. Driving both these factors were the complexity of using eight cantilever rakes. Those designs had to be developed, tested, and installed independently. Installation would require the aft portion of the inlet duct to be extensively reinforced. Thus, this evaluation quickly revealed that this approach was not viable for the HARV project. A literature search of past rake designs did not provide a viable alternative approach.^{4,5}

During an early design conception meeting, NASA and GEAE personnel conceived an alternative approach in which the eight rake legs would be joined at the center of the inlet with a hub similar to that of a wagon wheel. The rake would thus be one piece and would only have to consider shear loads (no moments) at its attachment points. This alternative would greatly simplify the structural installation requirements. Also, it was envisioned that the rake would slip up the back of the inlet ahead of the engine and attach to the main bulkhead near this location.

Similar wagon wheel rake designs of the past differ from the NASA and GEAE approach. Previous designs typically used a modified engine bullet nose which acted as the hub. The NASA and GEAE concept would be self-supported with no physical contact with the engine. This design would minimize vibrational and force transfer from the engine. The NASA and GEAE design would greatly simplify installation and aircraft modifications and significantly reduce aircraft down time. GEAE has successfully designed, developed and built one prototype and two flight-worthy rakes for less than \$500,000. One flight-worthy rake had an entire set of high-frequency response transducers included in the cost. The design details and specifications associated with the delivered rake along with its flight qualification testing are described in the

HARV Inlet Rake System and Flight Qualification Testing sections.

One significant advantage of the new rake design includes its transportability to other aircraft which use F404-GE-400 engines, such as other F/A-18, X-29, and X-31 aircraft. GEAE is currently under contract to determine the feasibility of extending the current design to supersonic flight conditions and to scale this design to larger inlet diameters.

HARV INLET RAKE SYSTEM

This section describes the HARV Inlet Rake System. The design and development of the HARV inlet rake system are detailed in the Rake Description, Pressure Transducer Selection, and Rake Fabrication subsections. Placement of the rake into the HARV is described in the Rake Installation subsection. A summary description of the rake system is described in the Operating Principles subsection.

Rake Description

The HARV rake is similar to a wagon wheel with the streamlined centerbody acting as the hub, the eight aerodynamic rake bodies being the spokes, and the inlet duct being the rim. The load-bearing structure is a welded Inconel 625* unit that joins the rake bodies and the central hub into a single piece that is supported by integral footpads and bolted to the aircraft inlet duct flange (fig. 5). Each of the eight rake legs contain five ports located on the centroids of five equal areas of the flow area. The ports are aligned within 2° of the anticipated steady-flow streamlines. The innermost port is the only one that had to be angled (5.5°) with respect to the rake body. All others were already within 2° of the flow angle.

The central hub also contains an isolated metal damper ring potted in the polyurethane centerbody (fig. 6). This configuration allows the damping material to dissipate vibration energy more effectively than an all-metal body. The same polyurethane material also forms the streamlining of both the centerbody and the trailing edges of the rake bodies. The rake bodies (or spokes) of the structure are made by forming sheet metal into the leading edge and sides of the airfoil

*Inconel 625 is a registered trademark of Huntington Alloy Products Division, International Nickel Company, Huntington Beach, West Virginia.

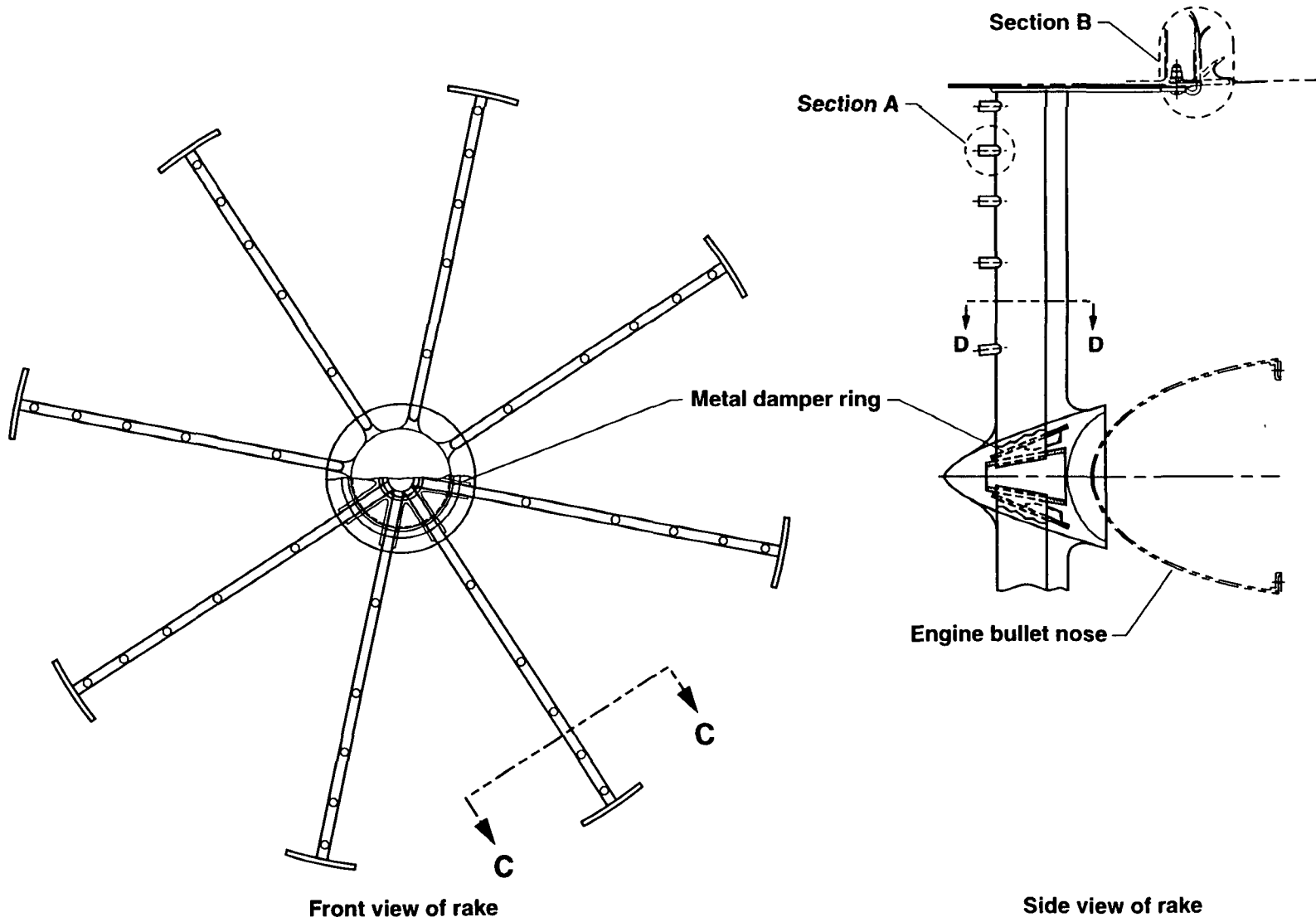

(a) Front and side views.
Figure 5. Inlet distortion rake.

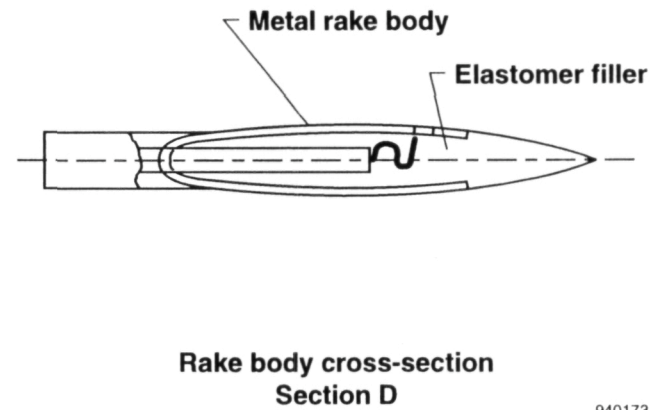
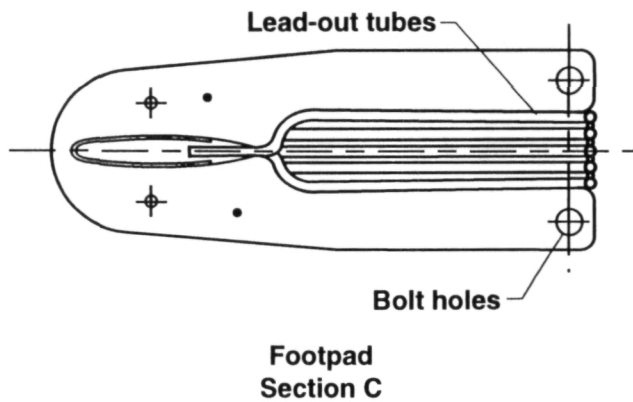
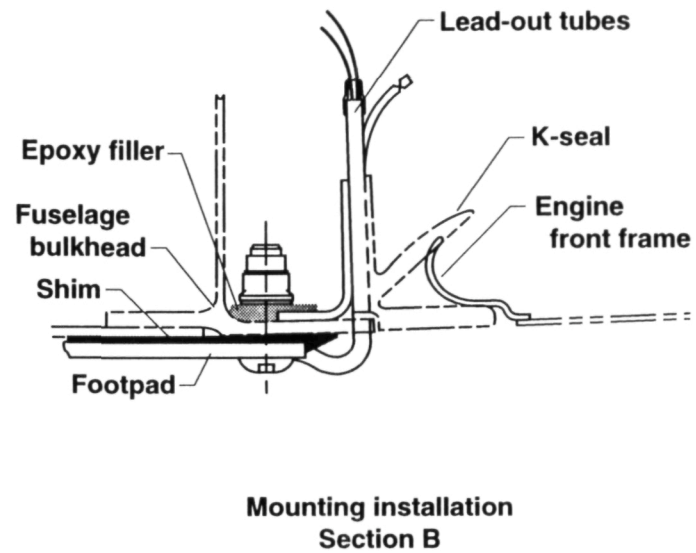
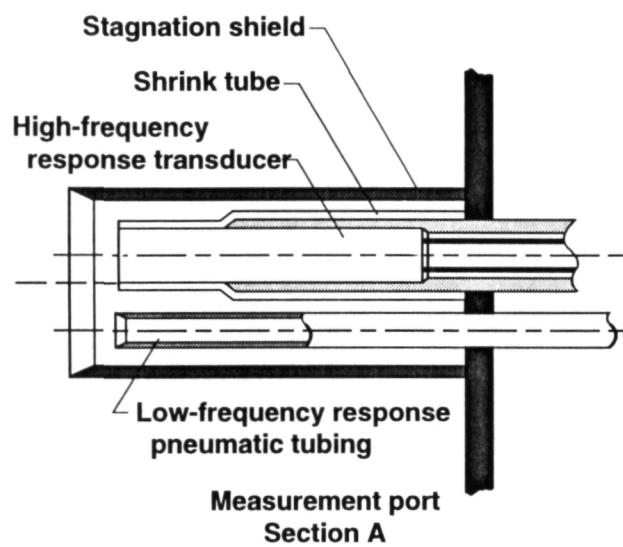

(b) Sections A through D.
Figure 5. Concluded.

940173

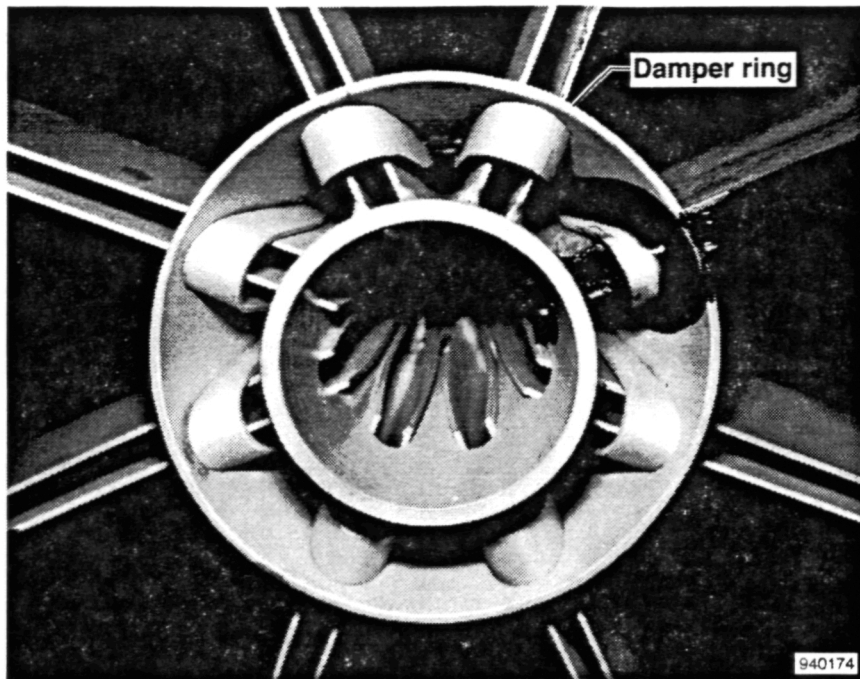

Figure 6. Floating damper ring.

shape. The sheet metal is left open at the trailing edge. This configuration allows the installation of the sensor and leadout tubes.

Flexane 94* is the polyurethane elastomer used as the potting and flow contour material. This 2 part mix, room temperature curing, pourable urethane bonds well to metal, meets the 618 °R maximum temperature requirement for this application, and has good vibration-damping properties. The rake assembly weighs approximately 15 lb.

The measurement plane of the sensors is located 4 in. in front of the bullet nose of the engine with the rakes oriented 45° from each other starting at 9° counter-clockwise off top center (aft looking forward (ALF)) for the right-hand inlet. This orientation satisfies the mounting accessibility and correspondence to previous test vehicle requirements. The rake sensors are shielded total-pressure-measuring sensors consisting of an impact-mounted high-frequency-response pressure transducer and a 1/16-in.-diameter, steady-state pressure tube. The stagnation shield configuration was tested to show its ability to measure the true total input pressure at varying flow angles. This configuration

*Flexane 94 is a registered trademark of Devcon Corporation, Danvers, Massachusetts.

allows the sensors to read true pressure levels at yaw angles from $\pm 25^\circ$ and pitch angles of 15° and -25° . Positive angle is toward the engine centerline. Maximum flow blockage is less than 8 percent of flowpath at the maximum thickness of the rake. This maximum thickness occurs 1.5 in. behind the AIP.

A composite material was not chosen for the rake because of increased design costs. Instead, the selection of the Inconel 625 frame with the bonded elastomer was an adequate compromise. The elastomer allowed the overall weight to be reduced and the rake struts to be aerodynamically shaped more easily than an all-metal body. In addition, the elastomer acted as an excellent damping material.

Pressure Transducer Selection and Installation

The NASA and GEAE team decided to use the same dual-probe configuration with low- and high-frequency response probes which had been used during the previous F/A-18A flight test for the HARV inlet rake. The low-frequency response probe would use 1/16-in. outside diameter (OD) tubing routed through the rake into the engine bay. A differential transducer with a reference pressure was selected. The DFRC has had a considerable amount of experience using ESP-3205BSL

differential transducers (Pressure Systems Incorporated (PSI), Hampton, Virginia). This transducer unit (fig. 7) was thermally stabilized to increase accuracy by minimizing thermal zero drift. This stabilization was accomplished by wrapping the transducer unit in a temperature-controlled thermal blanket. Another feature of the transducer, used to increase accuracy, was its ability to perform in-flight calibrations. This in-flight calibration allows for any calibration bias error to be removed during postflight data processing. The in-flight calibration is accomplished by applying the reference pressure to both sides of the differential transducer.

The right-hand ALF engine bay pressure was selected as the reference pressure for the ESP-3205BSL transducers. A Sonix PS1019 transducer (Pressure System Incorporated, Hampton, Virginia) was selected to measure the reference pressure. This pressure was chosen after careful consideration of a number of possible reference sources. Other possibilities included inlet duct throat wall static pressure, an inlet rake total-pressure port, and a pressurized tank. The inlet duct throat wall static pressure and inlet rake total-pressure ports were eliminated because of their unsteady pressure levels caused by inlet airflow variation. The pressurized tank was eliminated because of

increased maintainability requirements. The engine bay pressure was finally chosen because of its steady rate of change with altitude and its ease of installation on the aircraft. This pressure is also relatively unaffected by angle of attack.

The reference pressure range of the Sonix PS1019 transducer (0.4 to 19 psia) met the requirement of 2 to 16 psia. The range of the differential pressure transducer unit was sized to provide the smallest range about the reference pressure, while allowing for the expected differential between the engine bay pressure and the highly distorted total pressures at the inlet rake. A range of ± 5 psid was selected. This minimization of the differential pressure range allowed for increased resolution. Both the differential and reference pressure transducers were readily accessible. The differential transducer was located in the missile bay under the right wing ALF at the fuselage. The reference pressure transducer was located in the right-hand ALF landing gear wheel well. The differential and reference pressure transducer low-frequency response setups met the system accuracy requirements during stabilized aircraft maneuvers. This setup should not be depended upon during highly dynamic aircraft maneuvers. Instead, the high-frequency response instrumentation setup should be used.

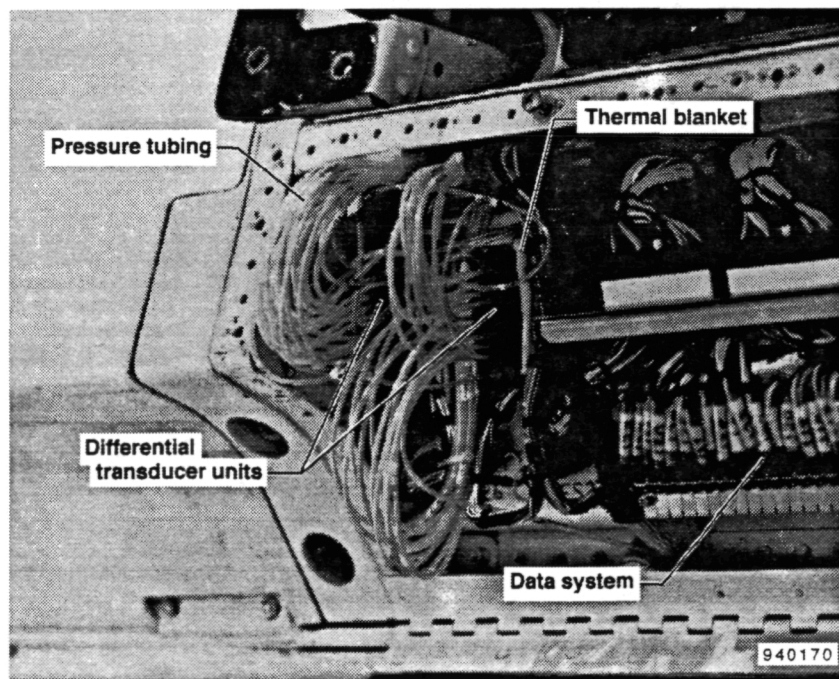

Figure 7. Installed HARV low-response differential transducer setup.

Each high-frequency response probe used an XCS-27L-093-20A temperature-compensated pressure transducer (Kulite Semiconductor Products, Inc., Leona, New Jersey). This transducer has a 0.093-in. diameter by 0.50 in. length with an absolute pressure range from 0 to 20 psia. The frequency response of this transducer met the 250 Hz requirement. Forty of these transducers were mounted at the rake measurement ports in close proximity to the low-frequency response pneumatic tubing (fig. 8). Each high-frequency response transducer had a protective FOD screen over the sensing element. This transducer was selected because of its ability to minimize thermal zero drift through passive temperature compensation. To further increase the accuracy of the transducer measurement, a series of pressure calibrations were performed over the entire required pressure and temperature range, up to 20 psia and at 395, 425, 460, 535, and 610 °R. Along with the measured engine inlet temperature, these calibrations would allow for any remaining zero thermal drift to be removed during postflight data processing. The differential transducer low-frequency response measurements will be used to verify the pressure levels of the temperature-compensated pressure transducer at stabilized conditions. This high-frequency response transducer setup allows for the accurate measurement

of high-frequency pressure levels during highly dynamic maneuvers and meets the system accuracy requirements.

The temperature-compensated pressure transducers were installed in the inlet rake 0.125-in. OD carrier tubes. These tubes have a 0.099-in. ID counterbore to receive the transducers. Installation was accomplished by feeding the transducer electrical leads through the 0.125-in. tube from the sensor end, coating the back of the transducer with room temperature vulcanizing (RTV) silicone adhesive, and inserting the transducer into the counterbore. Next, the transducer was covered with heat-shrinkable tubing, and the silicone adhesive was allowed to cure. Then, the shrink tube was trimmed flush with the transducer face. The lead exit was also sealed with the silicone adhesive and shrinkable tubing. This arrangement provided a secure mounting for the transducers but still allowed removal and replacement while the rake was still in the aircraft in case of transducer failure.

Rake Fabrication

Fabrication of the rake unit began with forming the sheet metal rake body airfoils, drilling them for the sensor tubes, and welding them to a machined hub. The

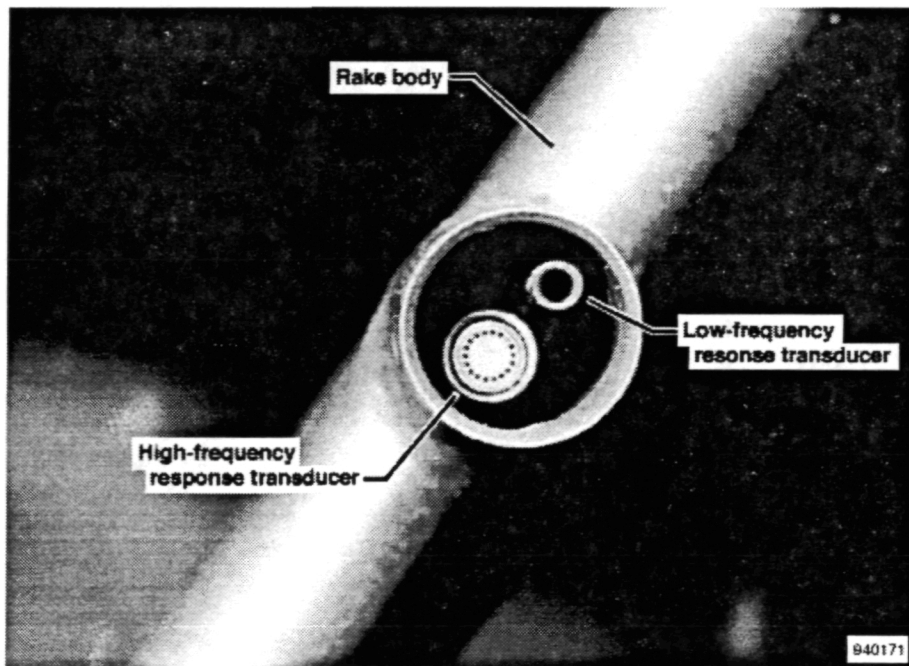
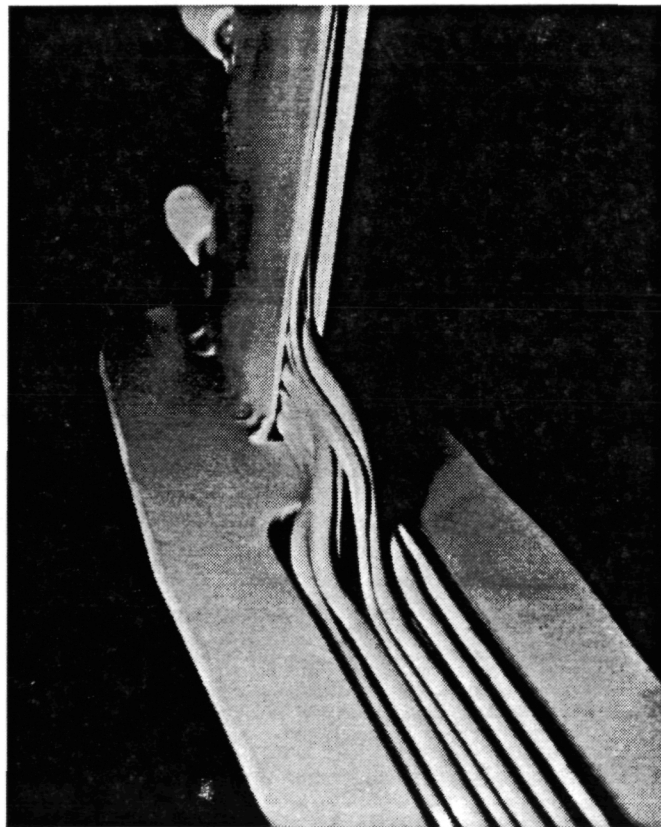

Figure 8. HARV inlet rake sensor setup with high-response, temperature-compensated pressure transducer installed.

footpads were then machined, formed to the duct radius, and welded to the rake bodies. After stress relieving, the welds were inspected using the florescent penetrant inspection technique. (This nondestructive inspection technique detects cracks by applying a penetrating fluorescent solvent to the material.) Sensor tubes and stagnation shields were then brazed in place with a gold and nickel braze. The bend radii in the leadout tubes were kept as large as possible to facilitate installation of the transducer leads later in the assembly (fig. 9). A damper ring was then installed around the hub and rake struts. Welds and brazes were reinspected after the metal fabrication portion of the assembly concluded. Strain gages were applied to the hub and rake bodies in the areas that would later be covered with polyurethane elastomer (fig. 10). The rake bodies were then filled and the trailing edges of the rakes were formed with the elastomer. The center hub form was then cast in place completing the airfoil blending of the rakes and centerbody. Figure 11 shows the completed rake assembly.

Rake Installation

Installation of the rake on the aircraft was accomplished after the right-hand engine (ALF) had been removed. The minimal airframe modifications that were required consisted of 1/4-in. bolt holes being drilled in the inlet duct flange aft of the rear bulkhead. These 16 holes were located by trial positioning the rake in the inlet duct, confirming that none of the bolt holes would interfere with any bulkhead bracing, and transfer-punching the hole locations through the rake-mounting footpads. Then, the rake assembly was removed, and the holes were drilled in the flange using a hand-held drill. Backup washers were then placed at each hole on the outside of the duct and epoxied in place to provide a solid and flat surface for seating the nuts of the rake-mounting bolts (fig. 5). This seating was done by inserting a nylon mandrel through the washer and rake-mounting holes in the duct to position the washers on an aluminum-filled epoxy base that filled the gap under the washer. These mandrels were removed after the epoxy had cured overnight.



EC 92 5192-3

Figure 9. Rake leg instrumentation tube leadouts.

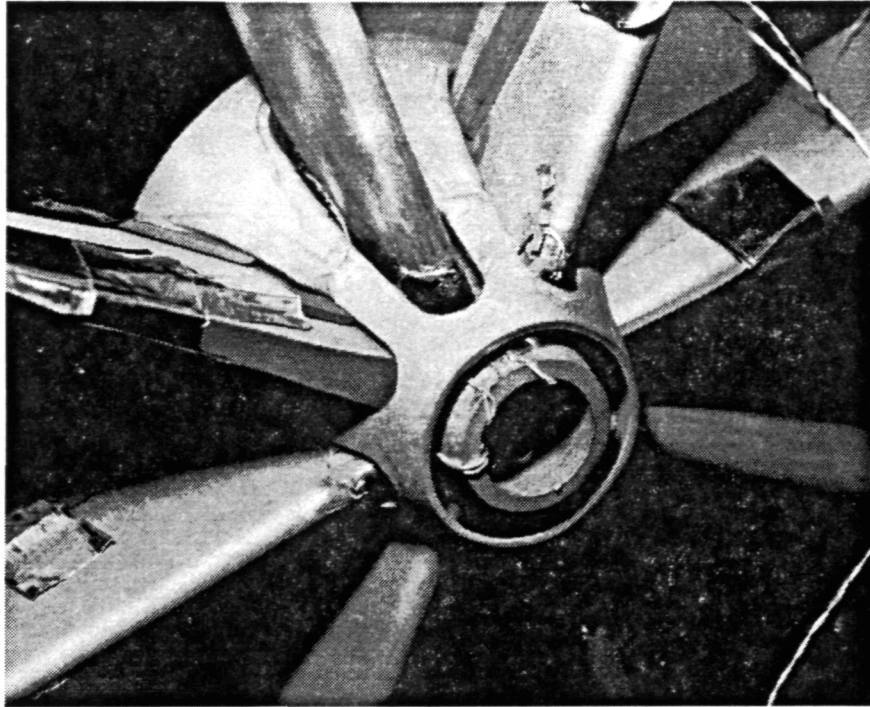

S 3405-2

Figure 10. Strain-gaged hub of distortion rake.

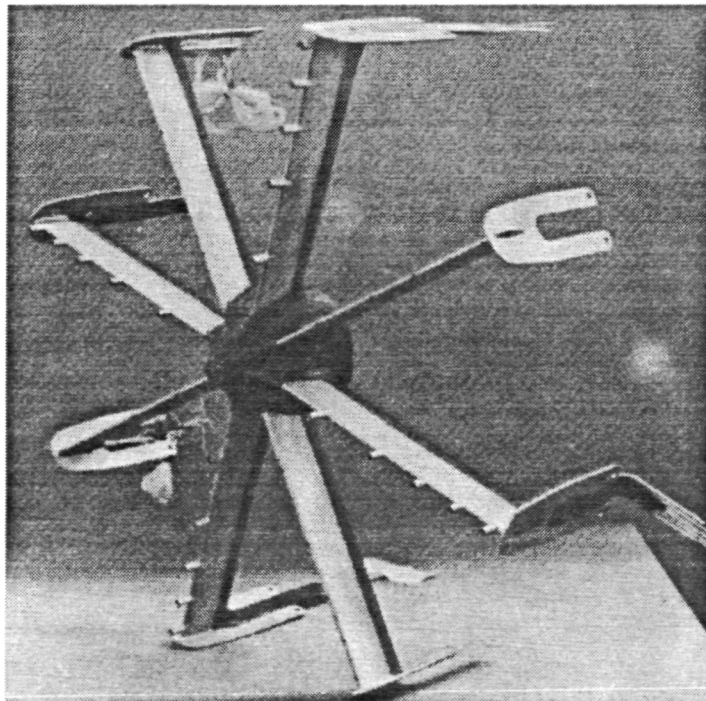

S 825-3

Figure 11. Completed prototype distortion rake with polyurethane elastomer rake leg fairings and centerbody.

Testing showed that this configuration could withstand over 200 in.-lb torque applied to the mounting bolts without deforming the washer, epoxy, or flange. The originally planned rework to the exit lip of the inlet duct was eliminated to retain as much of the original integrity of the flange as possible. To accomplish this goal, the leadout tubes of the rakes were reformed to exit the duct just behind the lip, and a support shim was made from polyurethane elastomer to support the tubes under the K-seal. This seal around the inlet duct exit provides the transition from the inlet duct to the engine front-frame lip. The K-seal was contoured to allow the rake tubes to pass freely under it (fig. 12).

The rake was placed in the duct. An even fit for each rake strut was achieved by placing shims between the rake metal footpad and the inlet duct wall. The rake assembly was then installed in its final position. Room temperature vulcanizing silicone adhesive was placed on each side of the fiberglass and polyurethane elastomer footpads. The metal footpads were then bolted in place, and the silicone adhesive was cured. This configuration gave the assembly a firm, elastomer-damped mounting.

The K-seal was then bolted in place on the aft duct flange. The electrical leads for the pressure transducers and the steady-state pressure tubes were routed to their respective connector locations. The rework to the

airframe, installation of the rake assembly, modification to the K-seal, and installation of the seal ready for lead routing was accomplished in less than 3 days.

Operating Principles

Single-piece construction of the HARV rake assembly resulted in a redundant structure that allows each spoke of the wheel configuration to share the load of the structure through the hub and transfer it to the airframe duct as shear loads to the bolts in the duct flange. These rakes are fastened at the footpad on the duct wall, allowing the duct flange to support the rake without inducing any bending load in the sheet metal wall of the duct.

Vibratory energy within the rake struts is damped as the flex and twist motion of the open-backed rakes put the polyurethane elastomer in shear. The elastomer is bonded to the sheet metal. Energy at the hub from the rake struts is dissipated using the action of the damping ring imbedded within the elastomer.

FLIGHT QUALIFICATION TESTING

Flight qualification testing consisted of three phases: laboratory, ground testing, and flight testing. The laboratory phase determines the baseline structural and

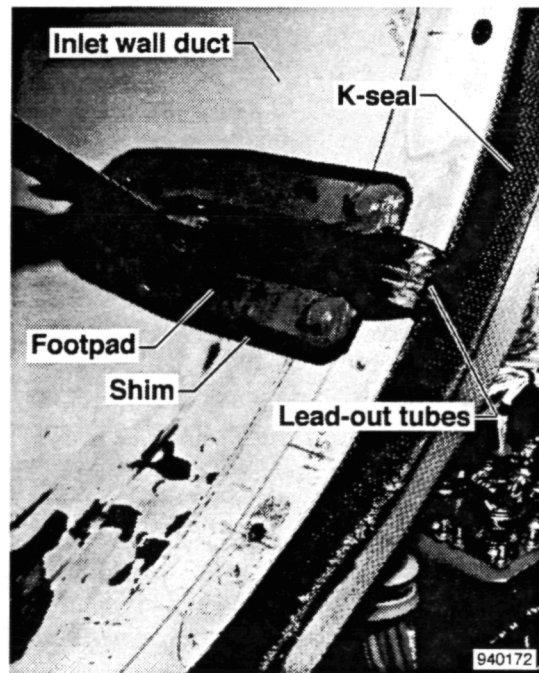

Figure 12. Instrumentation tubes passing under K-seal at exit lip of HARV inlet.

vibrational characteristics of the rake. This phase consists of rake modeling using NASA Structural Analysis (NASTRAN) along with Zonic ping (Zonic Corporation, Milford, Ohio) and vibrational shake table (Unholtz-Dickie Corporation, Wallingford, Connecticut) testing on a prototype rake. Results of this phase are compared to the environmental conditions that the rake will experience in operation. Then, baseline results from the laboratory tests are used for comparison with the results from the installed ground testing and flight testing phases. Each phase is described in the following subsections.

Laboratory Testing

Computer modeling of the rake structure using the NASTRAN program was used to identify the possible vibration modes and the approximate frequencies of those modes. The computer model identified 15 potential vibrational modes between 0 to 7000 Hz. Most of these modes could not be driven to significant levels during subsequent laboratory, ground, or flight testing.

The laboratory testing used a prototype rake instrumented with strain gages. This rake was installed in an inlet test fixture manufactured from a modified F/A-18 aircraft inlet. This test phase consisted of ping tests and vibration table testing. Objectives of vibration testing with the instrumented prototype were to:

1. Measure the vibration characteristics of the rake with axial and transverse excitation.
2. Determine the rake stress distribution at an established maximum rake stress level.
3. Excite the rake randomly at the flight qualification excitation level for a specified period without damaging the rake.
4. Excite the rake sinusoidally at its resonant frequency at a specified excitation level to empirically define the rake endurance limit.
5. Select the critical strain gage locations for ground test monitoring based on the strain-gage-derived stress distribution.

Twenty-eight dynamic strain gages were applied to two (of eight) rake struts. That is, 14 each on 2 struts spaced 90° with respect to each other and circumferentially oriented in the inlet so that one of the instrumented struts would be exposed to maximum excitation during the transverse vibration test. In

addition, accelerometers were mounted on the inlet test fixture and on the vibration table. This instrumentation would verify that there was no displacement amplification caused by resonance of the test fixture. This instrumentation was also used to verify the predicted damping characteristics of the rake structure.

Strain gage excitation and signal conditioning were accomplished by a GEAE designed and fabricated constant current excitation, alternating current (ac) coupled amplification system. Data were recorded on an X-Y plotter to show overall strain levels as a function of frequency. The instrumented inlet test fixture and rake assembly was mounted on a 17,500 lb capacity vibration table.

The ping test uses an instrumented hammer for applying a force to the rake structure and measures the resultant motion of the rake. This method identified four primary modes at which the rake might be driven. These modes were axial, torsion, strut bending, and second axial.

Vibration table testing consisted of three procedures: axial-sinusoidal, transverse-sinusoidal, and transverse-random excitation. The axial- and transverse-sinusoidal vibration test procedures required several steps. First, the rake was excited axially with respect to the engine centerline. Next, the rake was excited transversely using sinusoidal-driving forces over the frequency from 10 to 2000 Hz at 1-g excitation to locate the resonant frequencies of the rake. Then, the axial and transverse stress distributions were obtained by dwelling at the resonant points and increasing the input acceleration levels until the established maximum stress level was reached on one of the strain gages. Subsequently, the rake was exposed to transverse-random excitation (nonsinusoidal) over the frequency range of 15 to 2000 Hz at 18.4-g excitation (flight qualification level). Finally, the rake was vibrated at resonance at an excitation level necessary to verify the rake endurance limit.

Rake maximum stress levels were established by taking a number of factors into consideration. These factors included the material properties of the rake structure, placement and number of strain gages installed, stress concentrations, and safety margin. The stress limits of 30,000 and 50,000 lb/in² peak-to-peak (PSIPP), dependent on strain gage location, were used.

The axial-input frequency resonant sweep test showed an axial mode at 147 Hz with 1-g excitation. The input acceleration level was then increased until the maximum stress level of 30,000 PSIPP was reached. The maximum strain gage outputs were

located on the leading edge and trailing edge of the rake foil at the hub. A decrease in the axial mode frequency to 129 Hz at 3.8-g excitation was observed. The maximum response of 30,000 PSIPP at 3.8-g axial input meets the damping and structural design requirements of the rake. The lower resonance frequency (129 Hz) at the higher vibration level is a result of the soft mount interaction of the fixture and the elastomer-damping configuration. The soft mount of the test fixture is not representative of a full aircraft inlet. This soft mount was improved by adding bags of lead shot to the fixture. The frequency shift of the rake and the lower 1/rev crossover on the fan Campbell diagram (fig. 13) at the higher excitation level (147 Hz) is not critical to the highly damped rake structure.

Figure 13 shows the various vibration mode frequencies of the rake (axial, torsion, strut bending, and second axial) and lines representing multiples of fan rotor speed frequencies (1/rev, 2/rev) are superimposed across the entire fan rotor speed range. Any intersection allows for fan rotor speeds to be identified where rake resonance frequencies are likely to occur. For example, the rake axial mode resonance (147 Hz) is likely to occur at a fan rotor speed of approximately 8500 rpm. This low fan rotor speed means less energy which can be imparted onto the rake. Experience has

shown that axial excitation has never been a problem for an inlet rake installed directly in front of an engine.

The transverse-sinusoidal input sweep showed a resonant frequency of 123 Hz (a combination of rake axial mode and fixture resonance) and a strut bending mode of 240 Hz with the stress distribution remaining constant with increasing input levels. A transverse excitation of 7.8 g was reached at the maximum stress level of 30,000 PSIPP.

The transverse-random test provided a nonsinusoidal input to test the hardware for interaction and structural flaws caused by 18.4-g random input (flight qualification level) in the 15 to 2000 Hz frequency band. The test had to be performed for a minimum of 20 min to meet the flight qualification requirements. This test was performed for 26 min. Stress level and distribution data from the nonsinusoidal excitation are not related to the transverse sinusoidal sweep data. During the random tests, strain gages located on the leading and trailing edges of the rake foil near the footpad provided the highest relative output signals. Spectral data from the random excitation again indicated resonant frequencies of 129 Hz (rake axial with fixture resonance) and 240 Hz (strut bending). Based on the data from the vibration table tests, 12 strain gages at the leading and trailing edges of the airfoil at both the hub and the

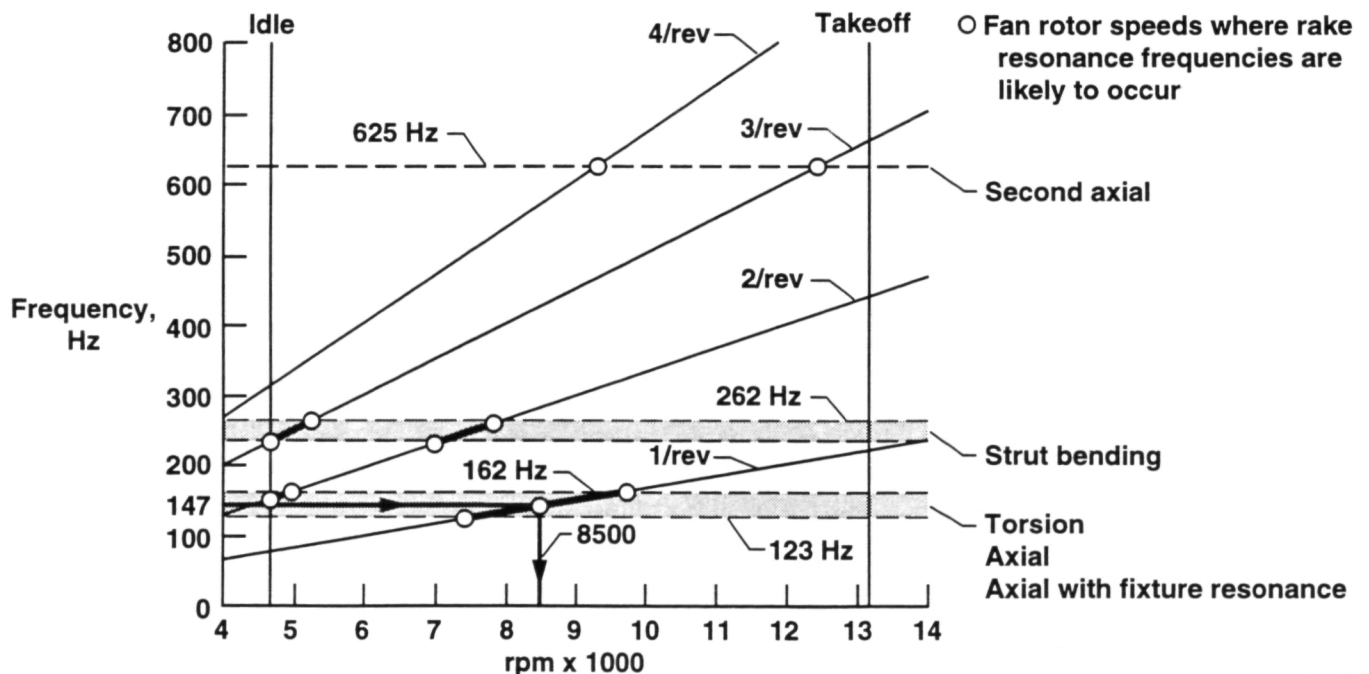

Figure 13. Campbell diagram showing rake vibration responses.

outer ends of the rake strut were selected to be monitored during the ground and flight test program. This test resulted in no structural damage to the rake.

Empirical determination of the structural endurance limit was attempted by exciting the rake at its resonant frequency at the required 10-g, transverse-sinusoidal level. The 10-g, transverse excitation showed a stress level of 41,000 PSIPP. The 10-g input was to be held until the rake structure failed or reached 10^7 vibration cycles. The duration would define the endurance limit. The resonant frequency changed from 122 to 117 Hz during the test. This change probably resulted from the heating effect on modulus of the elastomer potting material. The 10-g input level was extremely severe on the inlet test fixture. The test was shut down after 2 hr of dwell time at 10 g to avoid catastrophic damage to the test fixture. Empirical determination of the rake endurance limit could not be achieved because the high-damping characteristic of the rake made it significantly more durable than the inlet test fixture. The inlet test fixture could not tolerate excitation levels necessary to damage the rake. The rake system showed no signs of structural damage for the duration of the test and was confirmed with a posttest X-ray and visual inspection of the rake hardware.

The results of the vibration shake table test have been compared to the NASTRAN computer model predictions and to the ping test results. These dynamic analysis results are listed next.

Mode	NASTRAN model, Hz	Ping test, Hz	Vibration table, Hz
Axial	140	155	147
Torsion	147	162	N/A
Axial with fixture resonance	N/A	N/A	123-129
Strut bending	250	236-262	240
Second axial	594	625	N/A

The rake vibration testing confirmed the analytical design calculations. The laboratory results from the ping and vibration table tests formed the baseline predominant frequencies for comparison to ground and flight testing. A frequency shift limit of ± 20 percent was determined to be reasonable. Shifts greater than this limit indicate either a damaged or failed structural component. The stress limits of 30,000 and

50,000 PSIPP were satisfactory for use during ground and flight testing. Use of these limits depended on the location of the strain gage.

Ground Testing

A ping test was performed on the inlet rake installed in the F/A-18 HARV while in the hangar. This test was used to verify the results gathered during laboratory testing. Frequencies showed good agreement with the past laboratory ping test results.

The installed rake was ground tested on the F/A-18 HARV with the aircraft tied down. Twelve strain gages were monitored while the right-hand engine was operated through its full range with a slow acceleration from idle power to full maximum afterburning and a slow deceleration to idle power. This procedure allowed predominant frequencies to be identified over the entire fan rotor speed range. Stress levels and spectral data were taken during the test.

The spectra showed predominant frequencies of 153 and 162 Hz corresponding to axial and torsional frequencies and a broad band about 250 Hz at a lower level corresponding to strut bending modes. These predominant frequencies showed consistent agreement with the laboratory baseline frequencies. Maximum stress levels during the test were approximately 10 percent of limit. Again, the strain gages showing the greatest stresses were located at the leading and trailing edges of the airfoil, at the hub, and at the outer end of the rake strut.

Flight Testing

The four most active strain gages were located at the leading and trailing edges of the airfoil, at the hub, and at the outer end of the rake strut, and were selected for monitoring during rake qualification flights. Two were monitored by telemetry in real time, and two were recorded on the aircraft for postflight analysis.

Qualification runs for the rake consisted of flight points to give maximum unsteady loads (an angle of attack of 60° at an altitude of 20,000 ft), temperature and pressure (Mach 0.7 on the deck), and combination of temperature, pressure, and unsteady loads (Mach 0.9 at an altitude of 18,000 ft) within the HARV flight envelope. The latter two points were at the limits of the HARV flight envelope. The first point was flown to a high-angle-of-attack condition. The latter two points were obtained at the maximum maneuver-loading limit.

The spectra of the rake vibrations remained consistent with the ground and laboratory tests. The stress levels observed were 26 percent of limits during high-angle-of-attack flight and less than 10 percent of limits during maximum maneuver-loading flight. The maximum stress limits observed were 30 percent of limits during aircraft takeoff. Based on the laboratory, ground, and flight test results, the rake is now fully cleared for conducting flight research within the entire HARV flight envelope with no restrictions.

CONCLUDING REMARKS

An improved cost and installation-time saving inlet distortion pressure rake was successfully designed, built, and validated for flight testing on the F/A-18 HARV research aircraft. The innovative design consists of a one-piece, wagon wheel approach that resulted in ease of installation with minimal aircraft modifications. Design advantages include lightweight, high strength, low structural resonance, low flow blockage, and easy transducer removal and replacement. A prototype of the new rake was environmentally tested in a laboratory where it passed all vibration structural requirements. Ground test verified the expected frequency response predicted from laboratory test. Flight qualification was completed and the rake is now cleared for flight testing on the HARV aircraft. All stress levels observed during ground and flight qualification were less than 30 percent of limits.

The simple design approach and creative use of lightweight materials such as elastomers resulted in a superior rake design at a significantly lower cost than previous design approaches. The rake has promise of ease of transportability to other F404-GE-400 equipped aircraft. Further design efforts are expected to allow the

design flight envelope to be expanded to supersonic conditions and allow scaling to other aircraft inlets. The cost and time saving solution to the inlet rake design will allow the F/A-18 HARV to conduct important inlet research at flight conditions never before explored.

ACKNOWLEDGMENT

The DFRC, LeRC, and GEAE team members wish to recognize posthumously the creative energy brought by co-author Leon Lechtenberg to this project. It is unfortunate that his tragic and untimely death did not allow him to see the fruit of his labor that resulted in successful ground and flight clearance of this novel rake design.

REFERENCES

- ¹Amin, N.F. and D.J. Hollweger, "F/A-18A Inlet/Engine Compatibility Flight Test Results," AIAA-81-1393, July, 1981.
- ²*Inlet Total-Pressure-Distortion Considerations for Gas-Turbine Engines*, Society of Automotive Engineers Aerospace Information Report, AIR 1419, May 1983.
- ³*Gas Turbine Engine Inlet Flow Distortion Guidelines*, Society of Automotive Engineers Aerospace Recommended Practice, ARP 1420, Mar. 1978.
- ⁴Holzman, Jon K. and Gordon A. Payne, *Design and Flight Testing of a Nullable Compressor Face Rake*, NASA TN D-7162, Jan. 1973.
- ⁵Farr, A.P. and G.A. Schumacher, "System For Evaluation of F-15 Inlet Dynamic Distortion," *Symposium on Instrumentation for Airbreathing Propulsion*, MCAIR 72-043, Sept. 1972.

REPORT DOCUMENTATION PAGE

Form Approved
OMB No. 0704-0188

Public reporting burden for this collection of information is estimated to average 1 hour per response, including the time for reviewing instructions, searching existing data sources, gathering and maintaining the data needed, and completing and reviewing the collection of information. Send comments regarding this burden estimate or any other aspect of this collection of information, including suggestions for reducing this burden, to Washington Headquarters Services, Directorate for Information Operations and Reports, 1215 Jefferson Davis Highway, Suite 1204, Arlington, VA 22202-4302, and to the Office of Management and Budget, Paperwork Reduction Project (0704-0188), Washington, DC 20503.

1. AGENCY USE ONLY (Leave blank)	2. REPORT DATE October 1995	3. REPORT TYPE AND DATES COVERED Technical Memorandum
---	---------------------------------------	---

4. TITLE AND SUBTITLE Design and Development of an F/A-18 Inlet Distortion Rake: A Cost and Time Saving Solution	5. FUNDING NUMBERS WU 505-68
6. AUTHOR(S) Andrew J. Yuhas, Ronald J. Ray, Richard R. Burley, William G. Steenken, Leon Lechtenberg, and Don Thornton	

7. PERFORMING ORGANIZATION NAME(S) AND ADDRESS(ES) NASA Dryden Flight Research Center P.O. Box 273 Edwards, California 93523-0273	8. PERFORMING ORGANIZATION REPORT NUMBER H-2078
---	---

9. SPONSORING/MONITORING AGENCY NAME(S) AND ADDRESS(ES) National Aeronautics and Space Administration Washington, DC 20546-0001	10. SPONSORING/MONITORING AGENCY REPORT NUMBER NASA TM-4722
--	---

11. SUPPLEMENTARY NOTES
Presented as AIAA 94-2132 at the 7th Biennial AIAA Flight Test Conference, Colorado Springs, Colorado, June 20-23, 1994. A.J. Yuhas, PRC Inc., Edwards, California; R.J. Ray, Dryden Flight Research Center, Edwards, California; R.R. Burley, NASA Lewis Research Center, Cleveland, Ohio; W.G. Steenken, L. Lechtenberg, and D. Thornton, General Electric Aircraft Engines, Evendale, Ohio.

12a. DISTRIBUTION/AVAILABILITY STATEMENT Unclassified—Unlimited Subject Category 02	12b. DISTRIBUTION CODE
--	-------------------------------

13. ABSTRACT (Maximum 200 words)

An innovative inlet total-pressure-distortion measurement rake has been designed and developed for the F/A-18 A/B/C/D aircraft inlet. The design was conceived by NASA and General Electric Aircraft Engines personnel. This rake has been flight qualified and flown in the F/A-18 High Alpha Research Vehicle at NASA Dryden Flight Research Center, Edwards, California. The eight-legged, one-piece, wagon wheel design of the rake was developed at a reduced cost and offered reduced installation time compared to traditional designs. The rake features 40 dual-measurement ports for low- and high-frequency pressure measurements with the high-frequency transducer mounted at the port. This high-frequency transducer offers direct absolute pressure measurements from low to high frequencies of interest, thereby allowing the rake to be used during highly dynamic aircraft maneuvers. Outstanding structural characteristics are inherent to the design through its construction and use of lightweight materials.

14. SUBJECT TERMS F-18 aircraft; Flow measurement; In-flight monitoring; Inlet flow; Pressure measurement; Pressure sensors	15. NUMBER OF PAGES 21
	16. PRICE CODE A03

17. SECURITY CLASSIFICATION OF REPORT Unclassified	18. SECURITY CLASSIFICATION OF THIS PAGE Unclassified	19. SECURITY CLASSIFICATION OF ABSTRACT Unclassified	20. LIMITATION OF ABSTRACT Unlimited
--	---	--	--