

N96- 15593

AN INNOVATIVE APPROACH TO THE DEVELOPMENT OF A PORTABLE UNIT FOR ANALYTICAL FLAME CHARACTERIZATION IN A MICROGRAVITY ENVIRONMENT

Mark A. Dubinskiy, Mohammed M. Kamal, and Prabhakar Misra*

Laser Spectroscopy Laboratory
Department of Physics and Astronomy
Howard University
Washington, D.C. 20059

Introduction

The availability of manned laboratory facilities in space offers wonderful opportunities and challenges in microgravity combustion science and technology. In turn, the fundamentals of microgravity combustion science can be studied via spectroscopic characterization of free radicals generated in flames.

The laser-induced fluorescence (LIF) technique is a noninvasive method of considerable utility in combustion physics and chemistry suitable for monitoring not only specific species and their kinetics (ref. 1), but it is also important for imaging of flames (ref. 2). This makes LIF one of the most important tools for microgravity combustion science. Flame characterization under microgravity conditions using LIF is expected to be more informative than other methods aimed at searching for effects like pumping phenomenon that can be modeled via ground level experiments (ref. 3). Importance of LIF for two-dimensional temperature and species measurements, and for visualization and imaging of flames in microgravity was especially emphasized at the Second International Microgravity Workshop (ref. 4). However, it was noted that the lack of reliable, portable lasers tunable in the UV, based most probably on solid-state active media, was a major constraint for conducting actual microgravity experiments.

A primary goal of our work consisted in working out an innovative approach to devising an LIF-based analytical unit suitable for in-space flame characterization. It was decided to follow two approaches in tandem:

- (i) use the existing laboratory (non-portable) equipment and determine the optimal set of parameters for flames that can be used as analytical criteria for flame characterization under microgravity conditions; and
- (ii) use state-of-the-art developments in laser technology and concentrate some effort in devising a layout for the portable analytical equipment.

This paper presents an up-to-date summary of the results of our experiments aimed at the creation of the portable device for combustion studies in a microgravity environment, which is based on a portable UV tunable solid-state laser for excitation of free radicals normally present in flames in

* Author to whom correspondence should be addressed

detectable amounts. A systematic approach has allowed us to make a convenient choice of species under investigation, as well as the proper tunable laser system, and also enabled us to carry out LIF experiments on free radicals using a solid-state laser tunable in the UV.

On the proper choice of analytical species and precursors

The hydroxyl (OH) radical is an important species for combustion studies due to many reasons. According to recognized experts in combustion science: (i) the OH radical is convenient for study in a flame environment because its spectrum is easily characterized (unlike, say NO_2) and excited (ref.5), (ii) agreement between the experimental and calculated OH profiles is excellent (ref. 6), which makes OH an appropriate analytical candidate for flame-profile characterization under microgravity conditions. Compared to other radicals born in flames, the LIF signal from OH radicals is very strong and no complications associated with their detection occur. Therefore, the requirements for the UV tunable laser output energy are not so stringent; as well as requirements for the high voltage applied to the photomultiplier tube (PMT) normally used for LIF detection are more flexible. Thus, by choosing the OH radicals as the species for microgravity combustion studies, the weight-dimension characteristics of the analytical unit (including the tunable UV laser and the PMT-detection system) can be minimized, which is extremely important for airborne measurements in flight and aboard spacecraft.

A second important issue for in-flight and/or drop tower microgravity combustion experiments is a proper choice of precursors to obtain OH radicals. Part of our efforts has been devoted to the search for molecular precursor species that would be appropriate for investigation of combustion processes in flight (space) microgravity experiments. Another goal of these experiments has been to search for appropriate laser excitation regions that would yield data sensitive to a range of experimental conditions, so that besides being suitable for visualization and imaging of flames, we can also expect it to be appropriate for the search of gravity-sensitive features in laser-induced fluorescence excitation spectra recorded during flight experiments. Based on considerations of availability, the alkane family of gases - methane (CH_4), ethane (C_2H_6) and propane (C_3H_8), in order of increasing molecular weight and complexity - were chosen for burning. One expects a measure of commonality in free radical formation from the above gases due to their chemical similarity. This expectation was confirmed for air flames, when we studied laser-induced fluorescence excitation spectra for three alkane gases, recorded using a monochromator (employed at this stage as a variable narrowband UV filter) set at different wavelengths in a wide region of fluorescence from free radicals produced under air-combustion conditions. Fluorescence was detected using a R-1477 type PMT attached to the exit slit of a low-resolution ($f=100$ mm; $F/3.5$ aperture) H-10 type monochromator. The choice of this particular type of PMT was determined by its reduced sensitivity to the direct light from an open flame in the spectral region of registration (chosen to be 320 - 500 nm for OH radicals under consideration). The subject of study was the flame from a regular burner (without any premixing of gases) placed just in front of an entrance slit of the monochromator. No optics were used to image the flame on the entrance slit of the monochromator. Experimental set-up for these measurements is sketched in Fig. 1. Excitation of the OH radicals born in the combustion process was accomplished by a slight focusing of the tunable UV laser radiation (output radiation spectral bandwidth of 0.07 nm) in the 305-311 nm wavelength region within the flame. The excitation region corresponded to the $\text{A } ^2\Sigma^+ - \text{X } ^2\Pi (0,0)$ OH-absorption band. Tunable radiation in this part of our work was obtained in a traditional manner, using a tunable dye laser in the visible region of the spectrum, with subsequent frequency-doubling (described elsewhere, e.g., ref. 2, 5, 6). The lifetime of observed fluorescence was short and could not be measured very precisely within the time response limitations of our detector system used for these preliminary experiments.

The preliminary conclusions drawn from the series of experiments performed are as follows:

- For the three alkane gas-air flames, LIF excitation spectra recorded at the same registration wavelength are very similar. Since, analytically there appears to be no preference, the choice of

an appropriate species for burning may very well be made taking into account flame stability, price of starting materials and weight-dimension considerations relevant to a flight experiment. According to our data, the ethane-air combustion provides an example of the so-called fluctuation flame even under ambient conditions, which makes it inappropriate for studying important microgravity combustion features such as the pumping phenomenon (ref. 3). On the other hand, if we compare methane and propane, their flames are equally stable. At this point, propane seems to be the most appropriate, because it is available in a condensed state at room temperature and at relatively low pressure, and will occupy less space aboard an aircraft.

- LIF spectra of alkane-air flames excited in the region of the $A^2\Sigma^+ - X^2\Pi(0,0)$ OH-absorption band are sensitive to changes in experimental conditions (i.e., spectra are temperature-sensitive and positionally-sensitive in the flames). Also noticeable is their sensitivity to a particular wavelength of registration. As an example (because the results obtained with other studied alkane-air flames are qualitatively the same), Fig.2 shows LIF excitation spectra of a propane-air flame recorded at a registration wavelength of 330 nm (a) and 324 nm (b), respectively. The registration spectral bandwidth was $\text{FWHM} = 4$ nm. A comparison of Fig.2 (a) and (b) indicates a drastic change in the appearance of the excitation spectra with a change in registration wavelength by only 6 nm; and to the left and to the right of the spectral point around 327 nm there is no qualitative change in the spectra over a range of 60 nm. The reasons for such behavior are still under consideration, but it is quite clear that such anomalous alkane-air flame features may be useful for studies under microgravity conditions.

Analytical Application of the $\text{LiCaAlF}_6:\text{Ce}^{3+}$ Laser for Combustion Studies

As mentioned above, the main problem that one faces trying to devise a portable unit for flame characterization via UV laser induced fluorescence (LIF) analysis in space is that conventional (commercially available) UV tunable lasers are extremely cumbersome and energy-consuming devices that are not suitable for in-flight experiments. Indeed, such lasers, in addition to a pumping source (usually a YAG:Nd laser with an attached nonlinear frequency-doubler) need a tunable dye laser in the orange-red region of the spectrum and should be provided with a dye circulation system, as well as a system for frequency-doubling of the dye laser radiation with a servo-tuning system to follow the wavelength changes ("Autotracker") and also a system for separation of the visible and UV beams emanating from it ("Frequency Separator" in Fig. 1). Proceeding from state-of-the-art developments in quantum electronics, a reasonable way to overcome the problem is to use an all-solid-state tunable UV laser that employs direct pumping of the UV-active medium by UV harmonics from a YAG:Nd laser, and with no frequency transformation after the tunability stage (ref. 7). This emerging laser technology, which is only two years old, may allow the overcoming of drawbacks characteristic of traditional tunable UV laser systems. Promising results in this field have been demonstrated on the $\text{LiCaAlF}_6:\text{Ce}^{3+}$ (LiCAF:Ce) laser developed recently by M.Dubinskiy and co-workers (ref. 7-9) and the $\text{LiSrAlF}_6:\text{Ce}^{3+}$ (LiSAF:Ce) laser developed at the Naval Research Laboratory (ref. 10) and the Lawrence Livermore National Laboratory (ref. 11). To demonstrate the feasibility of our approach we have carried out preliminary experiments and succeeded in obtaining first positive results studying LIF of free radicals under the LiCAF:Ce UV tunable laser excitation at Howard University's Laser Spectroscopy Laboratory. Our considerations relevant to the choice of the source, a discussion of its advantages for applications such as flame characterization in space, and the results themselves, are summarized below.

Well-studied free radicals (that are also well-described theoretically and are therefore good combustion model subjects) are hydroxyl (OH) (ref. 12) and methoxy (CH_3O) (ref. 13, 14), which have analytically convenient excitation bands located in the 280 - 298 nm spectral region. Analytical equipment for routine LIF experiments with these radicals comprises usually an excimer laser delivering over 0.1 J of energy for photolyzing the precursor and a tunable ultraviolet laser consisting of a dye laser and a doubling stage for excitation of the fluorescence from the free radicals (ref. 15). As was emphasized above, it is hardly possible to use such equipment in space

because it is extremely cumbersome and energy-consuming. To the best of our knowledge, there have been no attempts to devise a portable all-solid-state unit suitable for spectroscopic measurements on free radicals in space. Such a development could promote significantly microgravity combustion science and applications.

The key-factor governing the design of a portable tunable UV laser for LIF excitation is a proper choice of "pumping source - active medium" combination so as to (i) avoid complications and energy consumption relating to the dye solution circulation and photochemical instability, (ii) to use the same efficient laser source for photolyzing the reaction species and for pumping the active medium, and (iii) to provide as high as possible "wall-plug" conversion efficiency for the device as a whole. Given the number of state-of-the art possibilities, we chose to use the newly discovered solid-state tunable UV laser based on the $\text{LiCaAlF}_6:\text{Ce}^{3+}$ (LiCAF:Ce) single crystal pumped by the quadrupled output of a Q-switched YAG:Nd laser (ref. 7-9). Our choice is based on the following considerations:

(i) - LiCAF:Ce laser is extremely efficient (most recent data - up to 30% slope efficiency (ref. 11) and photochemically stable (ref. 7,8,11) ;

(ii) - its available tunability (281 - 297 nm)(ref. 7,10) covers the region of excitation of OH and CH_3O free radicals ;

(iii) - 266-nm pumping radiation is efficient enough for photolyzing the precursor species, if necessary (ref. 16);

(iv) - LiCAF:Ce laser is the first known all-solid-state UV tunable device with direct pumping so that the portable unit devised will be compact.

For our first experiments we chose the methoxy radical, because its LIF is not so easy to observe, and thus observation of LIF using an all-solid-state tunable laser would be better proof of feasibility of approach, than say observation of OH fluorescence.

Fig. 3 represents the experimental arrangement for recording the excitation spectra of free radicals in the 291.5 - 296.5 nm spectral region based on the LiCAF:Ce tunable laser pumped by the fourth harmonic of the Q-switched Nd-YAG laser. The 266 nm output (about 10 mJ) was split into two beams of equal intensity, one of which was used for photolyzing the precursor and the other was used to pump the laser crystal. Pulse repetition rate of the computer-controlled device was 10 Hz; the LiCAF:Ce tunable laser output had a spectral bandwidth of 0.15 cm^{-1} , and the speed of spectral scanning was 0.5 nm/min. Tunability of the LiCAF:Ce laser was provided by a step-motor-driven Littrow-mounted diffraction grating. An optical scheme with counterpropagating photolyzing and excitation beams focused by fused silica lenses into the reaction vacuum chamber was employed. Fig. 4 represents a typical excitation spectrum of the methoxy (CH_3O) radical in the spectral region 291.5 - 296.5 nm obtained using the above-cited arrangement with CH_3ONO precursor and a time delay of 8 μs between the photolysis and probe pulses.

Thus, the laboratory experiment shows that the idea of using the LiCAF:Ce laser as an excitation source, in conjunction with a 266 nm pumping laser as a means for photolysis of the precursor species, provides a reliable solution for routine analytical investigations of combustion processes in space under microgravity conditions.

Acknowledgment

Financial support from the NASA Lewis Research Center (Grant #NAG3-1677) is gratefully acknowledged.

References

1. Crosley, D., "Collisional effects on laser-induced fluorescence flame measurements," *Optical Engineering* **20**, August 1981, pp. 511-521.
2. Allen, M., Hanson, R., "Planar laser-induced-fluorescence monitoring of OH in spray flames," *Optical Engineering* **25**, December 1986, pp. 1309-1311.

3. Durox, D., Bailott, F., Scoufflaire, P., Prud'homme, R., "Some effects of gravity on the behaviour of premixed flames," *Combustion and Flame* **82**, August 1990, pp. 66-74.
4. Weiland, K., "Visualization and imaging methods for flames in microgravity," *Proceedings of the Second International Microgravity Combustion Workshop*, Sept. 1992, pp. 135-140.
5. Smith, G., Dyer, M., Crosley, D. "Pulsed laser optoacoustic detection of flame species," *Applied Optics* **22**, December 1983, pp. 3995-4003.
6. Fleming, J., Burton, K., Ladouceur, H. "OH and CH profiles in a 10 Torr methane/oxygen flame: experiment and flame modeling." *Chemical Physics Letters* **175**, December 1990, pp. 395-400.
7. Dubinskii, M., Semashko, V., Naumov, A., Abdulsabirov, R., Korableva, S., "Ce³⁺-Doped Colquirite - a New Concept of All-Solid-State Tunable Ultraviolet Laser," *J. Mod. Opt.* **40**, January 1993, pp.1-5 .
8. Dubinskii, M., Semashko, V., Naumov, A., Abdulsabirov, R., Korableva, S., "Spectroscopy of a New Active Medium of a Solid-State UV Laser with Broadband Single-Pass Gain," *Laser Physics* **3**, January 1993, pp. 216-217.
9. Dubinskii, M., Semashko, V., Naumov, A., Abdulsabirov, R., Korableva, S., "Active Medium for All-Solid-State Tunable UV Laser," *OSA Proc. on Adv. Solid-State Las.*, A.Pinto and T.Fan, eds. (Opt. Soc. of Amer., Wash. DC, October 1993), v.**15**, pp. 195-198.
10. Pinto, J. , Rosenblatt, G., Esterowitz, L., Castillo, V., Quarles, G., "Tunable Solid-State Laser Action in Ce³⁺:LiSrAlF₆," *Electron. Lett.* **30**, February 1994, pp. 240-241.
11. Marshall, C., Payne, S., Speth, J., Krupke, W., Quarles, G., Castillo, V., Chai, B., In: 1994 OSA Proceedings on Advanced Solid-State Lasers, (Optical Society of America, Washington, D.C., 1994), vol. **20**, pp. 389-394.
12. Misra, P., Zhu, X., Nur, A., "Laser Induced Fluorescence Spectroscopy of the Hydroxyl Radical," *Spectr. Lett.* **25** (4), 547 - 557 (1992).
13. Misra, P., Zhu, X., Hsueh, C.-Y., Halpern, J., "Laser Excitation and Emission Spectroscopy of the Methoxy Radical in a Supersonic Jet," *Chem. Phys.* **178**, 377-385 (1993).
14. Williams, B., Fleming, J., "LIF Detection of Methoxy in CH₄/O₂/NO₂N₂ Flames," *Chem. Phys. Lett.* **221**, April 1994, pp. 27-32.
15. Misra, P., Zhu, X., Nur, A., "Rotationally-Resolved Excitation Spectroscopy of the Methoxy Radical in a Supersonic Jet," *Spectr. Lett.* **25** (5), 639-649 (1992).
16. Nur, A., "Laser Induced Fluorescence Spectroscopy of the Hydroxyl and Methoxy Radicals," M.S.Thesis, Howard University, Washington, D.C., 1991.

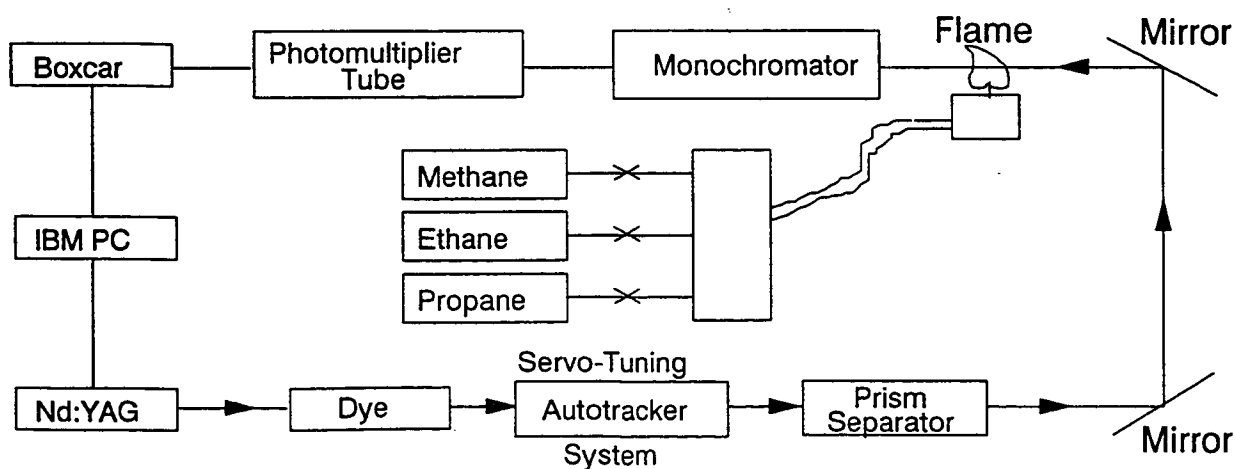

Figure 1: Experimental arrangement for recording laser excitation spectra of free radicals in alkane-air diffusion flames.

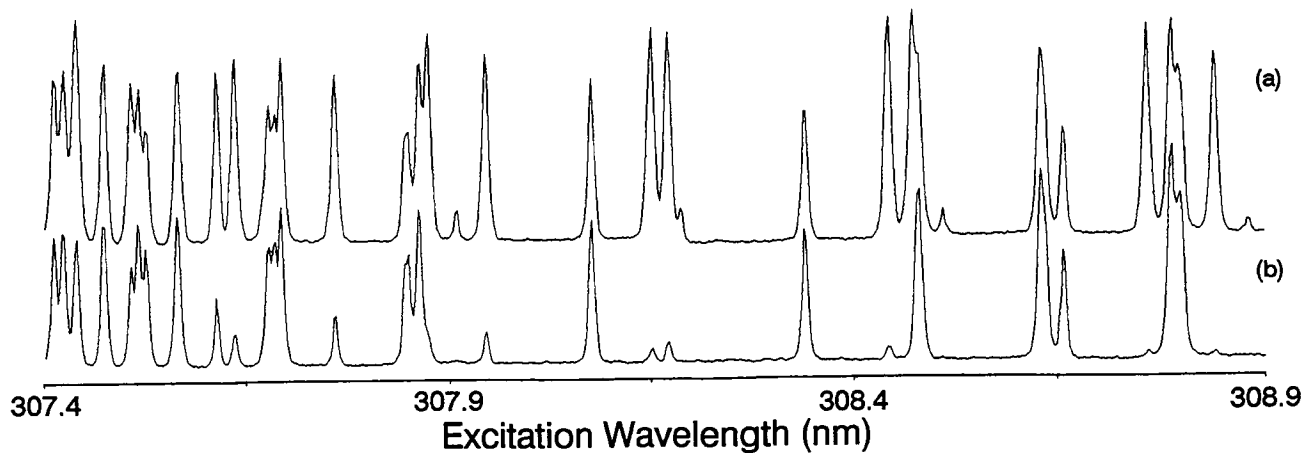

Figure 2: LIF excitation spectra of propane-air flame: (a) Registration wavelength 324 nm; (b) Registration wavelength 330 nm.

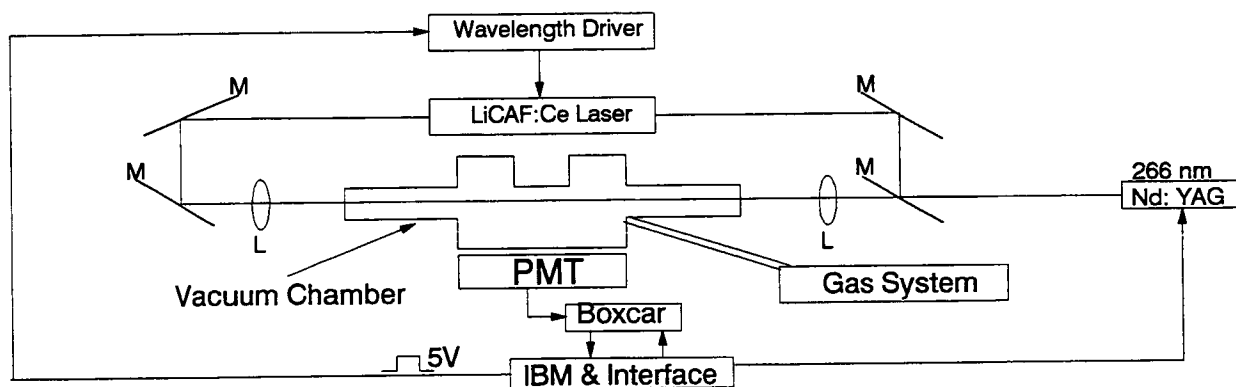

Figure 3: Experimental set-up for recording the UV excitation spectra of free radicals using a tunable all-solid-state LiCAF:Ce laser.

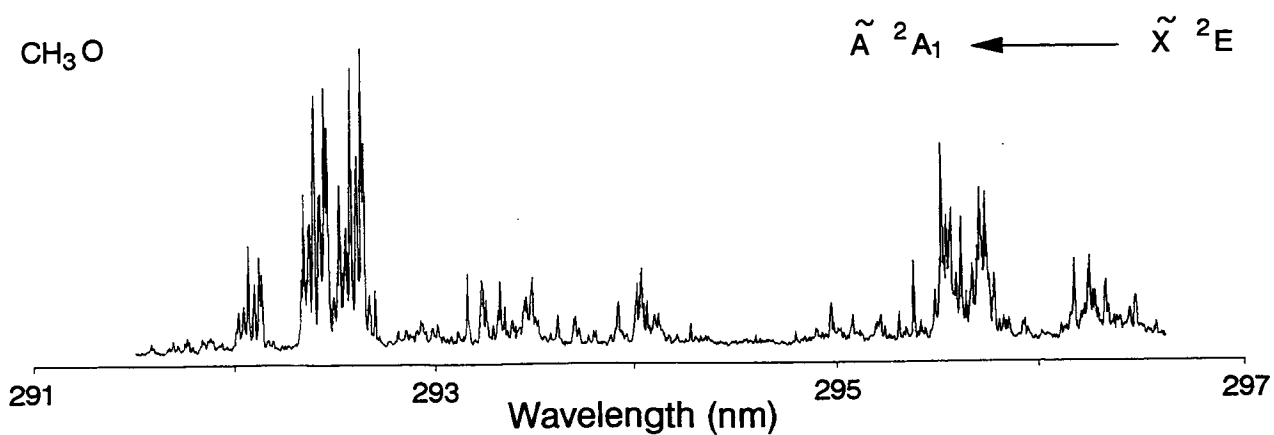

Figure 4: Laser excitation spectrum of the methoxy (CH_3O) free radical.