

N96- 15599

AN IMAGING SPECTROMETER FOR MICROGRAVITY APPLICATION

Wallace K. Wong
SSG, Inc.
Waltham, Massachusetts

Introduction

Flame structure is the result of complex interaction of mechanisms operating in both unwanted fires and controlled combustion systems. The scientific study of gas-jet diffusion flames in reduced-gravity environment is of interest because the effects of buoyancy on flow entrainment and acceleration are lessened. Measurements of flames have been restricted to cinematography, thermocouples, and radiometers. SSG, Inc. is developing an MWIR Imaging Spectrometer (MIS) for microgravity flame measurements. The device will be delivered to NASA Lewis at the end of this project to demonstrate flame measurements in the laboratory. With proper modifications, the MIS can be used to monitor a gas-jet flame under microgravity on an NASA Learjet or DC-9.

Instrument Concept

The MIS is a spatially scanned imaging spectrometer. Figure 1 illustrates the spectrometer concept. The instantaneous field of view (IFOV) of the instrument is defined by a slit behind an objective lens. This slit is imaged onto the central column of the FPA for the central wavelength, and on the end columns for the minimum and maximum wavelengths respectively. The FPA consists of 128 x 128 Indium Antimonide (InSb) photodiodes. Each detector column corresponds to the y-orientation and each detector row corresponds to 128 spectral components of the pixel corresponding to the crossing column. The scan mirror is synchronized with the FPA start of frame so that the footprint of the slit will advance by one footprint width on successive frames. After 128 FPA frames, a square image is collected. Post processing of the data block can produce an image of various spectral aggregates or a spectrum for part of the image. Figures 2 and 3 are compiled from the breadboard MIS developed during Phase I of this project.

Design Characteristics

The MIS design is optimized for flame measurements under microgravity on an NASA airplane. The parameters are tabulated on Table 1. Figure 4 shows the optical configuration. The mechanical package has been designed to be used with another instrument on an existing NASA free-floating rig. Figure 5 shows the hardware and the overall layout. The scan mirror is placed 30.5 cm (12.0 inches) from the flame at the center of a combustion chamber.

The Amber Engineering, Inc. Model 4128C camera system consists of a 128 x 128 InSb FPA packaged in a liquid nitrogen dewar; and the Amber Electronics. The dewar is custom modified with aluminum foam and burst disk and pressure relief valve for Learjet or DC-9 microgravity use. The hold time is more than six hours with 0.3 liters of liquid nitrogen. The Amber Electronics converts the analog at-dewar Trans-Impedance Amplifier (TIA) signals into a 12-bit digital video format. The 12-bit digital signal is first conditioned, then stored in the random access memory (RAM) of the Pentium PC. The fastest reliable frame rate is 109 Hz.

For a square image, 128 frames are collected as a 128 x 128 x 128 data cube. Each data cube is approximately 4 megabytes. The scan efficiency is approximately 75%. Therefore, successive data cubes are collected every 1.6 seconds. The MIS computer has 64 megabytes of RAM that can store 15 data cubes during a data collection period of 24 seconds. For reference, the NASA Model 25 Learjet can provide 22 to 25 seconds of reduced gravity.

During a typical experimental scenario, the MIS would be set up and held at the Stand-By Mode. When Zero-G condition is approaching, the operator will ignite the flame and press the MIS data collection TTL trigger switch to start data collection. After the data run, the data in RAM can be copied with header information to the hard disk memory. After multiple trails, the data is transferred from the disk to an 8-mm tape cartridge of an internal tape drive.

Operation and Software

The MIS Software has three modules: ImSet, ImDat and ImSpec. ImSet and ImSpec are applications under MS Windows; ImDat must run under MS DOS.

ImSet: This is the programmable experiment setup routine which allows the user to set parameters for the next data set. The ImSet has simple user interfaces, such as experimental configurations, that can be read from the hard disk. The configuration file includes the camera and frame grabber I/O board setup parameters. Header information can also be tagged to the data block to support subsequent quick look data identification.

ImDat: The user must reboot the PC prior to running this software. A TTL trigger switch provides synchronization with the ignition of the flame. The pointing mirror will move back and forth to perform the spatial scanning function. Successive spatial/spectral data are collected with the mirror scanning in opposite directions. No data is collected during the overscanned intervals. On average, the stepper motor moves two steps for each FPA readout frame. The stepper motor is synchronized with the master clock internal to the Amber Electronics.

ImSpec: This data visualization and analysis software is developed under Interactive Data Language (IDL) for MS Windows. The array processing capability of IDL allows simple arithmetic on data cubes such as coaddition and background subtraction. Figure 6 illustrates the main screen functions. The image can be recompiled to display a narrower aggregate of spectral components. The data range graphically illustrates the band center position and bandwidth. Other menu functions are provided to ease data visualization and analysis. SSG will also provide NASA with IDL for a UNIX Workstation. The ImSpec software will be modified for use on a UNIX computer.

Status and preliminary results

SSG is developing a laboratory MWIR imaging spectrometer instrumentation for microgravity applications. The data acquisition rate is once every 1.5 seconds for a 128 x 128 x 128 data cube. Our MIS instrument is designed with Learjet microgravity flights in mind. The operation of this instrument on the bench will be demonstrated at NASA Lewis by late spring of 1995.

Acknowledgements

This work is sponsored by NASA Lewis Research Center under a Phase II SBIR, Contract No. NAS3-26554. The NASA technical monitor is Dr. Karen Weiland. Stewart Radiance Laboratory in Bedford, Massachusetts provides subcontractual support to this project.

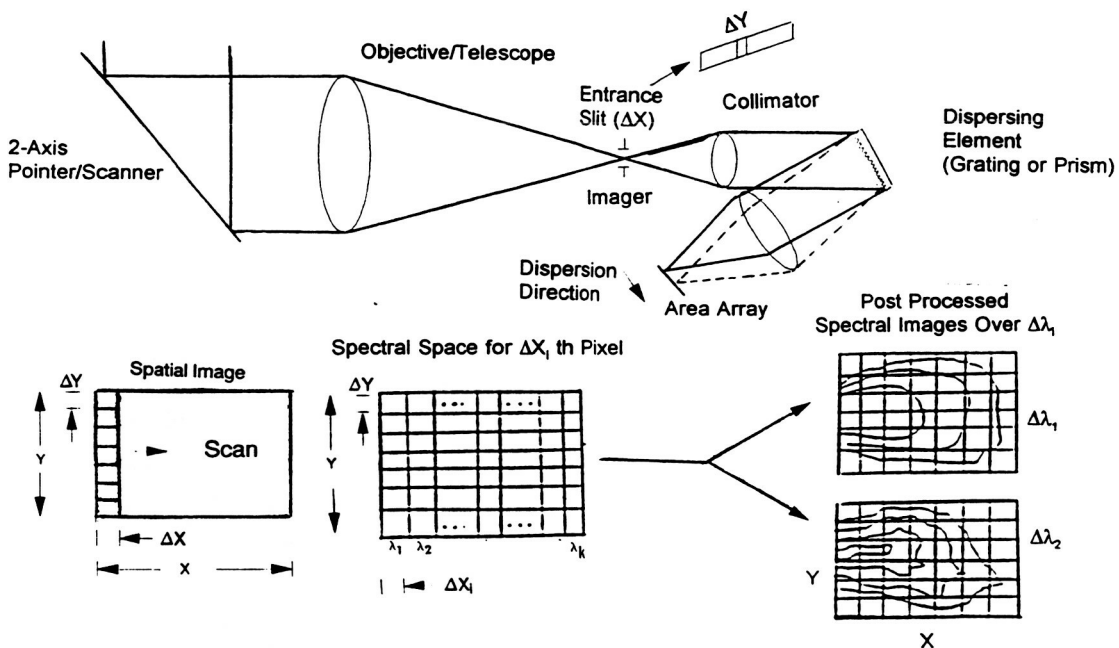
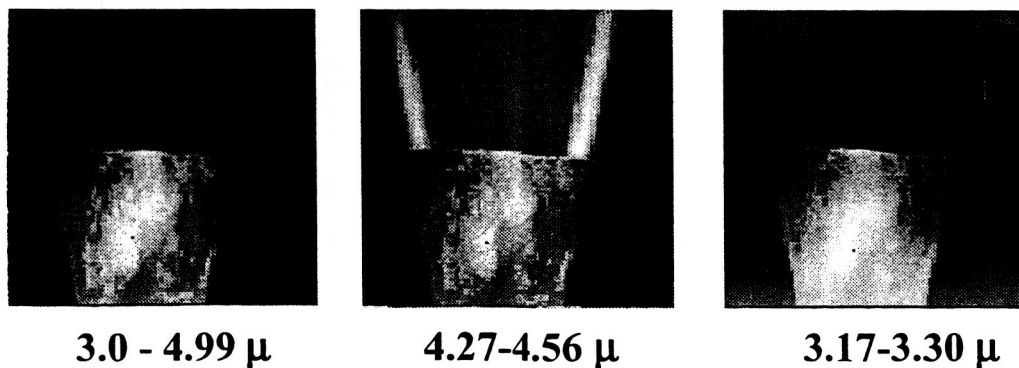
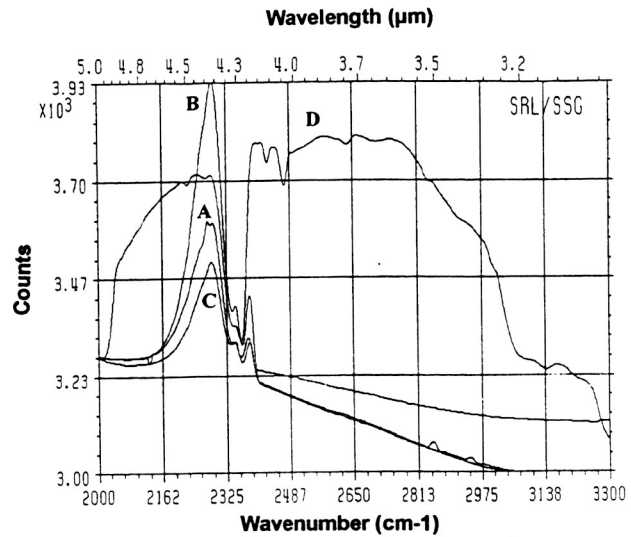
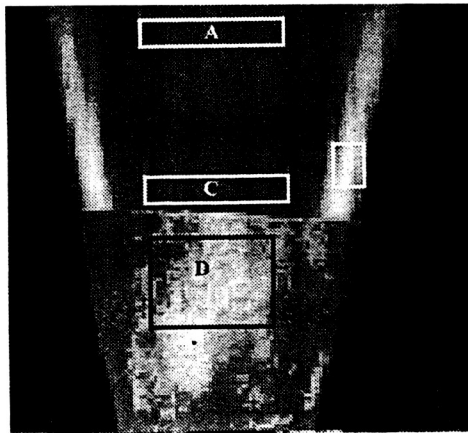

Figure 1. Spatially Scanned Imaging Spectrometer Concept



Propane Torch Flame and Nozzle

Figure 2. In-Band Images from One Scan



NASA Lewis Spectrometer Torch Data

Propane Torch Data

Figure 3. Spectra from Selected Regions in an Image

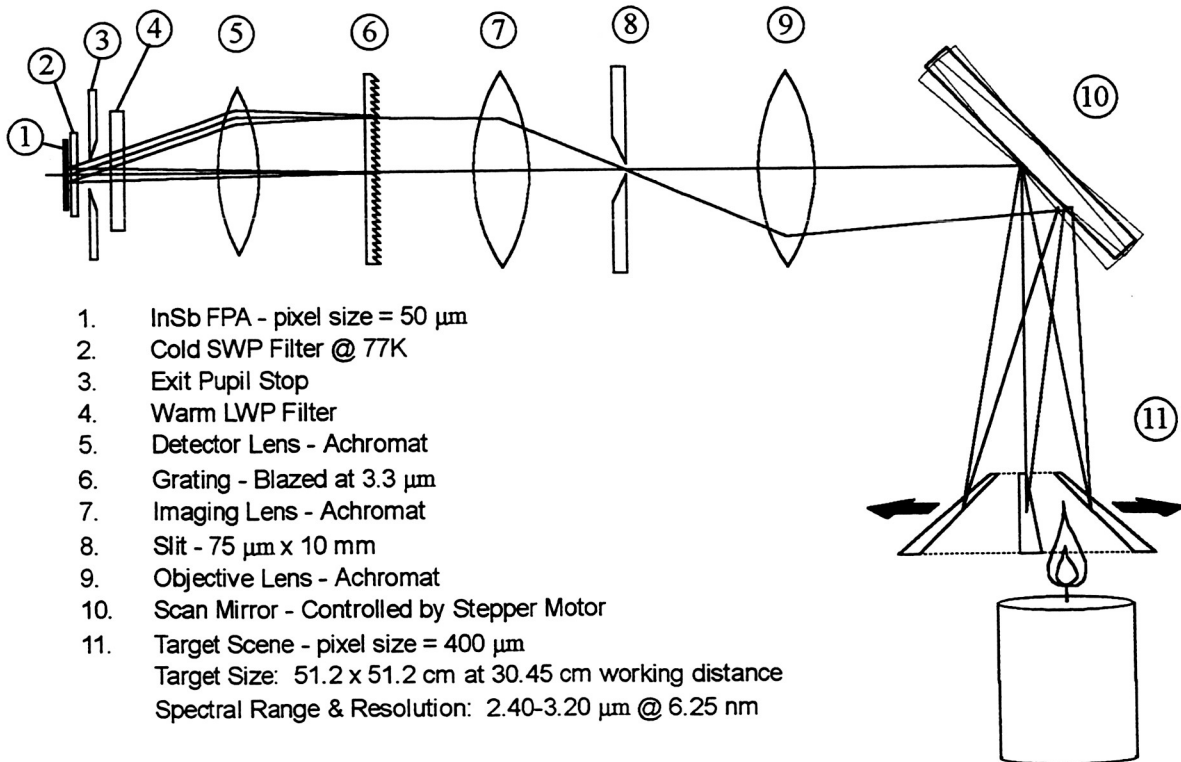

Figure 4. Optical Configuration

Table 1. Instrument Optical Characteristics

PARAMETER	UNIT	DESIGN VALUES	NOTES
Spectral Range	micron	2.4 - 3.2	FPA / optics / grating
Spectral Components	-	128	Limited by 128 X 128 FPA
Spatial Resolution		128	Limited by 128 X 128 FPA
Detector Material		InSb	Amber 4128 camera
FPA Format		128 x 128	Multiplexed digital output
Detector Pitch	micron	50.0 x 50.0	~43 x ~43 active area
Slit width x height	micron	75 x 6400	1 x 128 IFOVs
Demagnification		8	
Spatial Resolution	micron	400	distance of 40 cm between lens and flame!
Spatial Coverage	mm	0.4 x 51.2	1 x 128 IFOVs
Final F-number		2.3	at Detector
Optics type		achromats	3, at ambient temperature
Achromats coating		AR	2 - 5 micron
Grating	groove/mm	120	reflector, blazed at 3.25 μ m
SWP Filter - cold	micron	cutoff @ 3.5	inside dewar
LWP Filter - warm	micron	cuton @ 1.9	outside dewar window
dewar window material		Silicon	2 - 5 micron AR coated
Dewar	$^{\circ}$ K	77	alum.foam, Abs. press.relief valve, burst disk, hold ~ 7 hr.
Digitization		12	4096 levels
Data Acq. System			Pentium microprocessor based PC
Data Acq. Rate	Mbyte/s	10	Matrox Frame Grabber
Data Cube Collection Rate	second	1.6	Data Cube: > 128x128x128x2 Byte
NESR	W/cm ² -str- μ m	5.6e-6	calculated

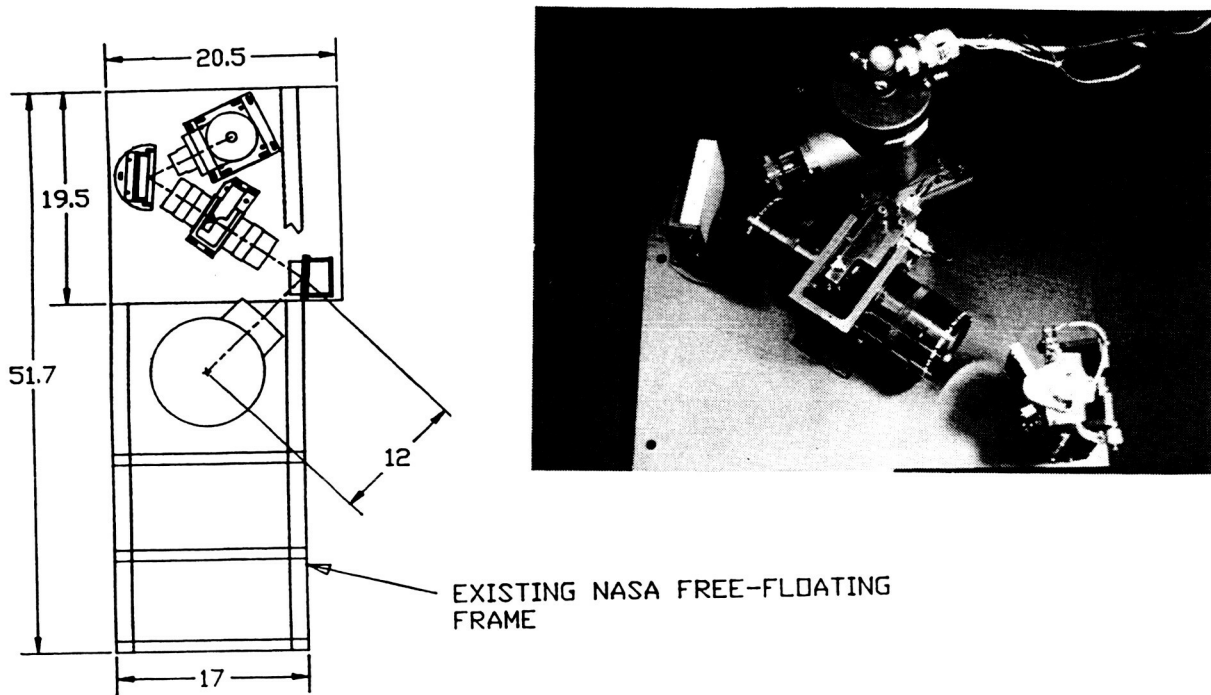

Figure 5. Optical Hardware and Overall Layout

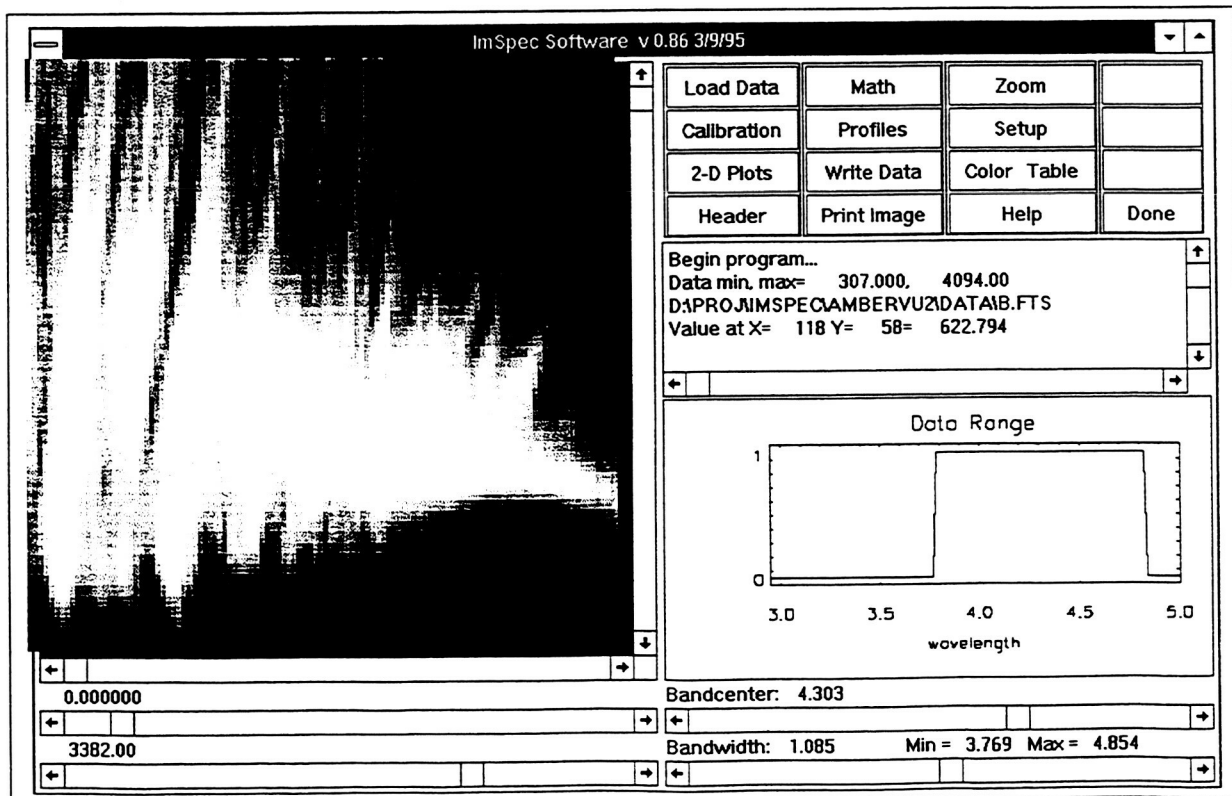

Figure 6. Main Screen Functions