

111 111
- 111 111

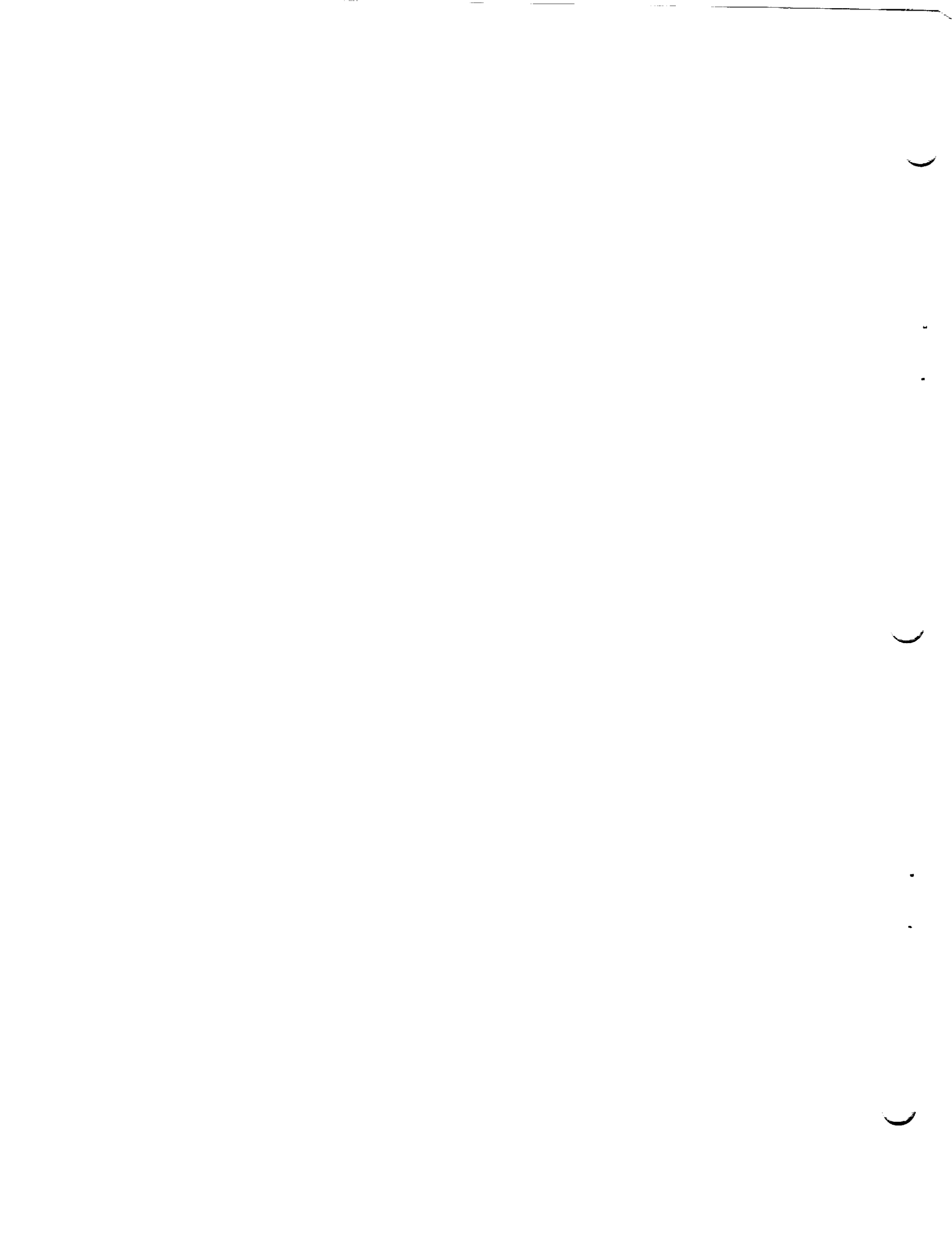

Debris/Ice/TPS Assessment and Integrated Photographic Analysis of Shuttle Mission STS-72

Gregory N. Katnik



Debris/Ice/TPS Assessment and Integrated Photographic Analysis of Shuttle Mission STS-72

*Gregory N. Katnik
Vehicle Engineering/Mechanical System Division/ET-SRB Branch,
Kennedy Space Center, Florida*

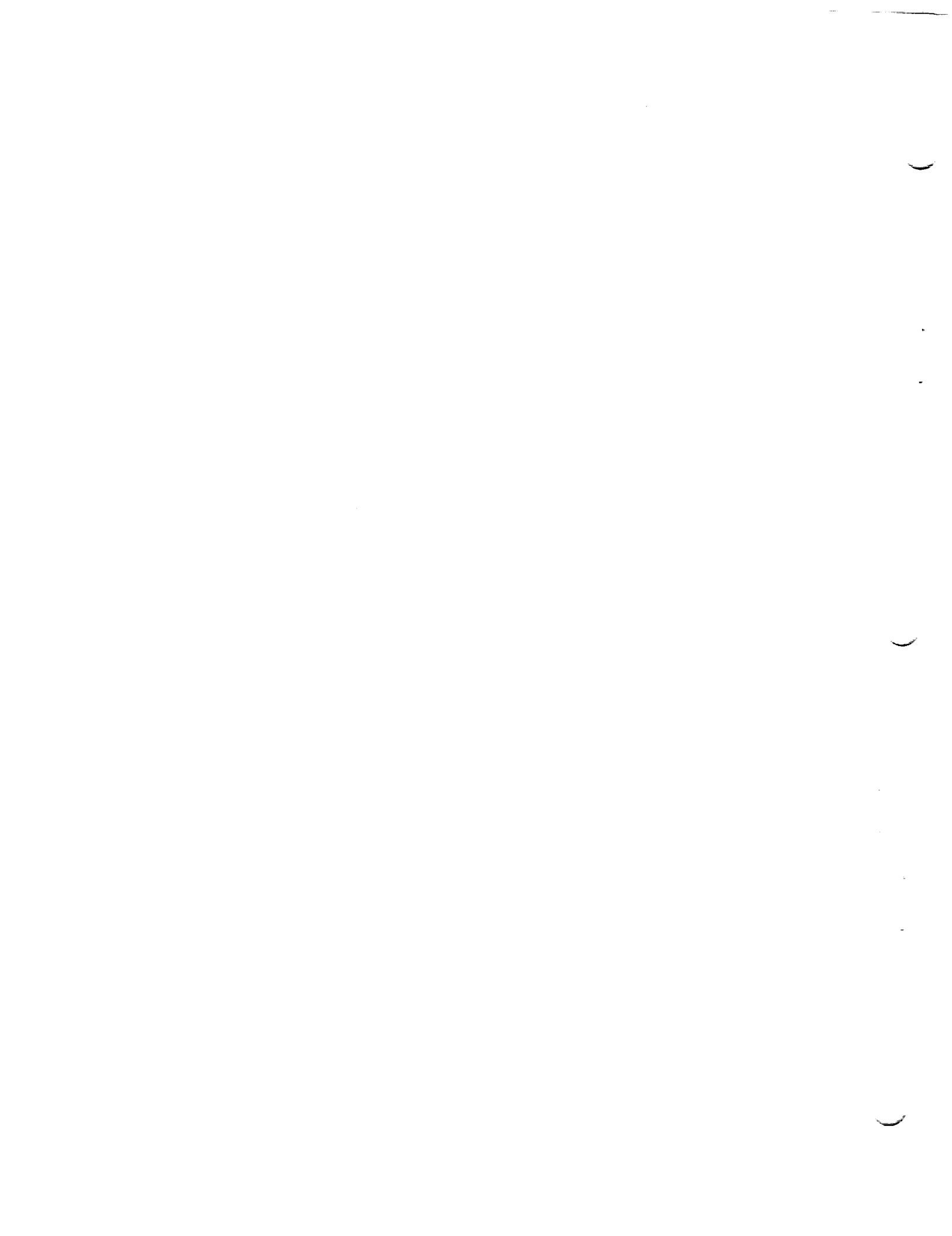

**DEBRIS/ICE/TPS ASSESSMENT
AND
INTEGRATED PHOTOGRAPHIC ANALYSIS
OF
SHUTTLE MISSION STS-72**

11 January 1996

Contributions By:

**NASA, Lockheed-Martin, Rockwell, and Thiokol Members of the
Debris/Ice/TPS and Photographic Analysis Teams**

Prepared By:



**Jill D. Lin
Shuttle Ice/Debris Systems
NASA/KSC/TV-MSD-7**

Approved:

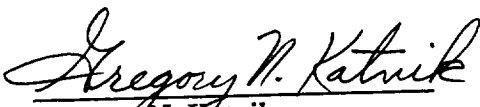

**Gregory N. Katnik
Shuttle Ice/Debris Systems
NASA/KSC/TV-MSD-7**

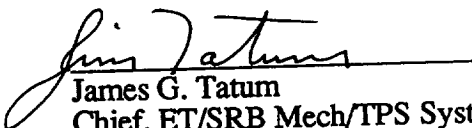

**James G. Tatum
Chief, ET/SRB Mech/TPS Systems
NASA/KSC/TV-MSD-7**

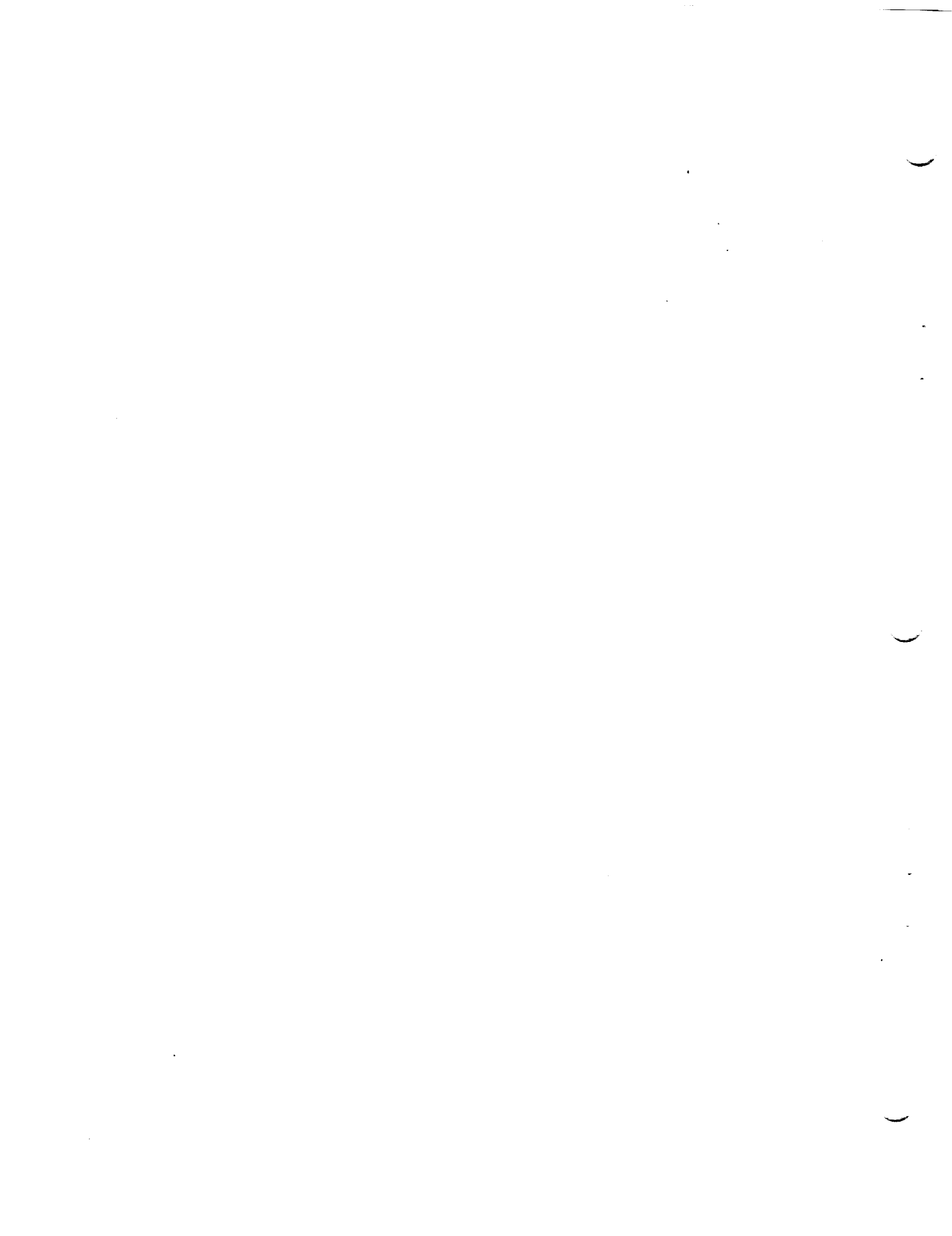

TABLE OF CONTENTS

TABLE OF CONTENTS	i
TABLE OF FIGURES	ii
TABLE OF PHOTOS	iii
FOREWORD.....	iv
1.0 SUMMARY.....	2
2.0 PRE-LAUNCH BRIEFING	4
3.0 LAUNCH.....	5
3.1 PRE-LAUNCH SSV/PAD DEBRIS INSPECTION.....	5
3.2 FINAL INSPECTION	5
3.2.1 ORBITER	5
3.2.2 SOLID ROCKET BOOSTERS.....	5
3.2.3 EXTERNAL TANK.....	5
3.2.4 FACILITY	10
4.0 POST LAUNCH PAD DEBRIS INSPECTION	18
5.0 FILM REVIEW.....	20
5.1 LAUNCH FILM AND VIDEO SUMMARY	20
5.2 ON-ORBIT FILM AND VIDEO SUMMARY	22
5.3 LANDING FILM AND VIDEO SUMMARY	24
6.0 SRB POST FLIGHT/RETRIEVAL DEBRIS ASSESSMENT.....	25
6.1 RH SOLID ROCKET BOOSTER DEBRIS INSPECTION.....	25
6.2 LH SOLID ROCKET BOOSTER DEBRIS INSPECTION	31
7.0 ORBITER POST LANDING DEBRIS ASSESSMENT	36
8.0 DEBRIS SAMPLE LAB REPORTS	51
8.1 PRELAUNCH ORBITER WINDOWS.....	51
8.2 PRELAUNCH ORGANIC ANALYSIS.....	51
8.4 POSTLANDING ORBITER WINDOWS.....	51
9.0 POST LAUNCH ANOMALIES	55
9.1 LAUNCH PAD/SHUTTLE LANDING FACILITY	55
9.2 SOLID ROCKET BOOSTERS	55
9.3 EXTERNAL TANK.....	55
9.4 ORBITER	55
APPENDIX A. JSC PHOTOGRAPHIC ANALYSIS SUMMARY.....	A
APPENDIX B. MSFC PHOTOGRAPHIC ANALYSIS SUMMARY.....	B

TABLE OF FIGURES

FIGURE 1: VEHICLE SURFACE TEMPERATURE STI MEASUREMENTS	7
FIGURE 2: VEHICLE SURFACE TEMPERATURE STI MEASUREMENTS	8
FIGURE 3: SURFACE COMPUTER PREDICTIONS	9
FIGURE 4: RH SRB FRUSTUM	26
FIGURE 5: LH SRB FRUSTUM	32
FIGURE 6: ORBITER LOWER SURFACE DEBRIS MAP	38
FIGURE 7: ORBITER RIGHT SIDE DEBRIS MAP	39
FIGURE 8: ORBITER LEFT SIDE DEBRIS MAP	40
FIGURE 9: ORBITER UPPER SURFACE DEBRIS MAP	41
FIGURE 10: ORBITER POST FLIGHT DEBRIS DAMAGE SUMMARY	42
FIGURE 11: ORBITER POST LANDING MICROCHEMICAL SAMPLE RESULTS	52
FIGURE 11 (CONTINUED): ORBITER POST LANDING MICROCHEMICAL SAMPLE RESULTS	53
FIGURE 11 (CONTINUED): ORBITER POST LANDING MICROCHEMICAL SAMPLE RESULTS	54

TABLE OF PHOTOS

PHOTO 1: LAUNCH OF SHUTTLE MISSION STS-72	1
PHOTO 2: ET-75 CRYOLOADED FOR LAUNCH	6
PHOTO 3: ET/ORB LH2 UMBILICAL	11
PHOTO 4: ET INTERTANK AND LO2 TANK BARREL AFTER CRYOLOAD	12
PHOTO 5: LH2 TANK +Y+Z QUADRANT	13
PHOTO 6: OVERALL VIEW OF LH2 TANK	14
PHOTO 7: LO2 FEEDLINE BELLOWS AND SUPPORT BRACKETS.....	15
PHOTO 8: OVERALL VIEW OF GUCP.....	16
PHOTO 9: LOWER QUARTER VIEW OF HYDROGEN VENT QD	17
PHOTO 10: AFT SKIRT SHOE SHIM	19
PHOTO 11: FLAME IN ENGINE PLUME.....	21
PHOTO 12: SRB SEPARATION FROM EXTERNAL TANK	23
PHOTO 13: RH FRUSTUM	27
PHOTO 14: RH FORWARD SKIRT	28
PHOTO 15: UPPER STRUT FAIRING MISSING K5NA	29
PHOTO 16: RH AFT BOOSTER/ AFT SKIRT.....	30
PHOTO 17: LH FRUSTUM	33
PHOTO 18: LH FORWARD SKIRT.....	34
PHOTO 19: LH AFT BOOSTER/ AFT SKIRT.....	35
PHOTO 20: OVERALL VIEW OF ORBITER LEFT SIDE	43
PHOTO 21: OVERALL VIEW OF ORBITER NOSE	44
PHOTO 22: VIEW OF BASE HEAT SHIELD.....	45
PHOTO 23: LOWER SURFACE TILE DAMAGE	46
PHOTO 24: DEBRIS FOUND ON RUNWAY UNDER UMBILICAL CAVITY	47
PHOTO 25: LO2 ET/ORB UMBILICAL	48
PHOTO 26: LH2 ET/ORB UMBILICAL	49
PHOTO 27: ORBITER WINDOWS 1 - 3	50
PHOTO 28: ORBITER WINDOWS 4 - 6	50

FOREWORD

The Debris Team has developed and implemented measures to control damage from debris in the Shuttle operational environment and to make the control measures a part of routine launch flows. These measures include engineering surveillance during vehicle processing and closeout operations, facility and flight hardware inspections before and after launch, and photographic analysis of mission events.

Photographic analyses of mission imagery from launch, on-orbit, and landing provide significant data in verifying proper operation of systems and evaluating anomalies. In addition to the Kennedy Space Center Photo/Video Analysis, reports from Johnson Space Center and Marshall Space Flight Center are also included in this document to provide an integrated assessment of the mission.



Photo 1: Launch of Shuttle Mission STS-72

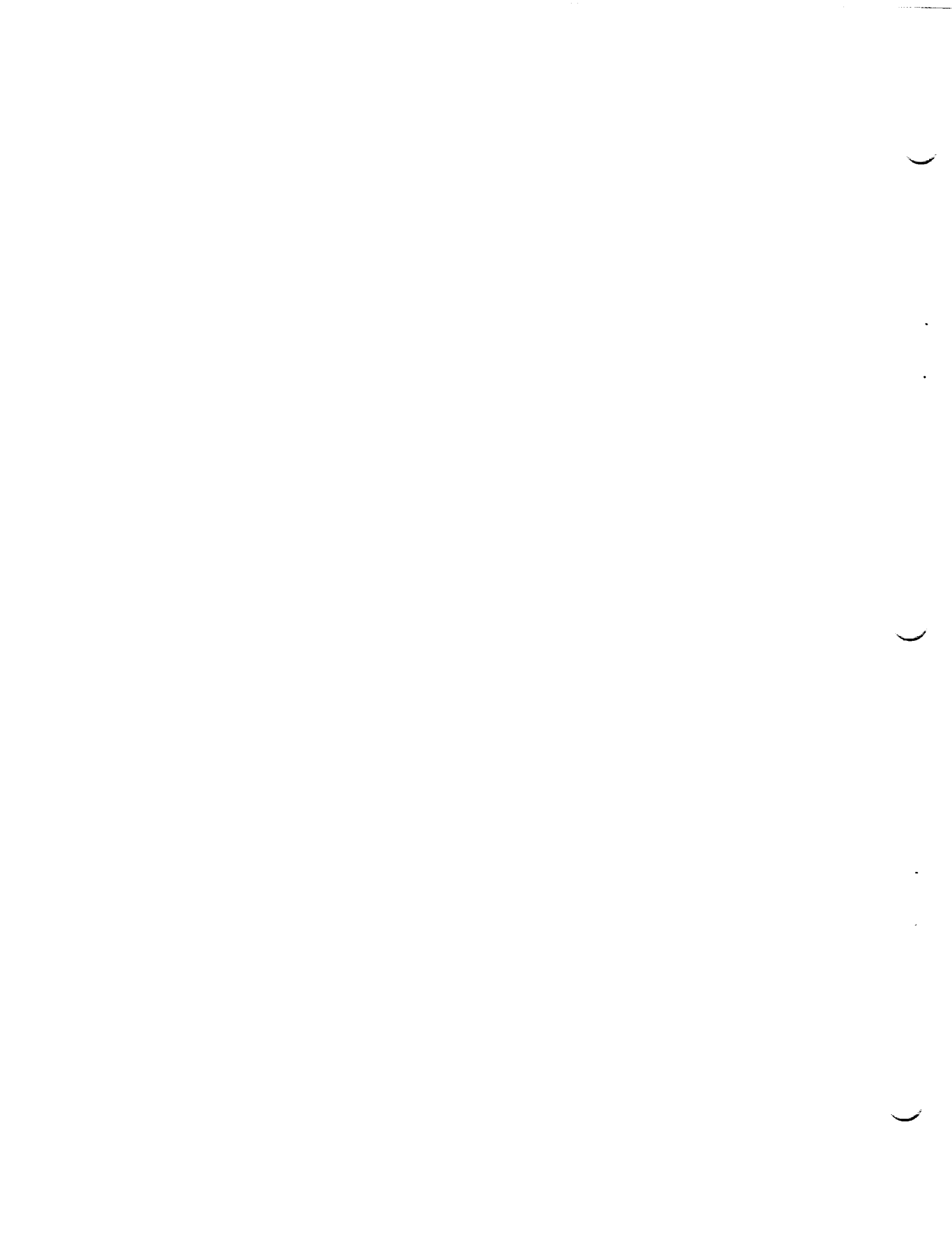

1.0 SUMMARY

A pre-launch debris inspection of the launch pad and Shuttle vehicle was performed on 10 January 1996. The detailed walkdown of Pad 39B and MLP-1 also included the primary flight elements OV-105 Endeavour (10th flight), ET-75 (LWT 68), and BI-077 SRB's. There were no significant vehicle or pad anomalies.

The vehicle was cryoloaded for flight on 10 January 1996. There were no Launch Commit Criteria (LCC), OMRS, or NSTS-08303 criteria violations. No IPR's were taken. Due to ambient weather conditions at this time of year, the potential existed for acreage icing. Frost, but no detectable ice, formed on the +Y side of the External Tank. There were no protuberance icing conditions outside of the established data base.

After the 4:41 a.m. (local) launch on 11 January 1996, a debris walk down of Pad 39B was performed. No flight hardware or TPS materials were found. All the T-0 umbilicals operated properly. A small amount of topcoat from the External Tank nose cone adhered to the northeast GOX seal. Overall, damage to the launch pad was minimal.

A total of 100 films and videos were analyzed as part of the post mission data review. No vehicle damage or lost flight hardware was observed that would have affected the mission. SSME ignition appeared normal.

No stud hang-ups occurred on any of the holddown posts. No ordnance fragments or frangible nut pieces fell from any of the DCS/stud holes.

Orbiter umbilical camera films showed nominal separation of SRB's from the External Tank and normal separation of the ET from the Orbiter. The LH2 ET/ORB umbilical appeared to be in good condition with little or no TPS damage. Foam was missing or eroded from the horizontal (clamshell) section of the cable tray and the aft surface of the -Y vertical strut. Pieces of charred foam impacted the LH SRB aft booster and broke into smaller pieces.

The Solid Rocket Boosters were inspected at Hanger AF after retrieval. From a debris standpoint, both SRB's were in excellent condition. The number of MSA-2 debonds on both frustums was average.

Orbiter performance as viewed on landing films and videos during final approach, touchdown, and rollout was nominal. Drag chute operation was also normal.

A post landing inspection of OV-105 was conducted 20 January 1996 on SLF runway 15 at the Kennedy Space Center. The Orbiter TPS sustained a total of 55 hits, of which 6 had a major dimension of 1-inch or larger. Based on these numbers and comparison to statistics from previous missions of similar configuration, both the total number of hits and the number of hits 1-inch or larger was exceptionally less than average.

The Orbiter lower surface sustained a total of 23 hits, of which 3 had a major dimension of 1-inch or larger. The largest lower surface tile damage site occurred approximately 15 feet forward of the RH MLG wheel well and measured 6.0-inches long by 0.375-inches wide by 0.25-inch maximum depth. The only debris found on the runway under the umbilical cavities (LH2) consisted of a bolt 0.875-inches long by 0.1875-inches in diameter with a red coating on the head. The bolt, stamped with the number MS 21279-7, is used in the Orbiter aft compartment SSME wire bundle clamps. A post flight inspection of the aft revealed no missing bolts (Ref. Lost and Found PR LAF-5-11-0199).

Orbiter post landing microchemical sample results revealed a variety of residuals in the Orbiter window samples from the facility environment, SRB BSM exhaust, Orbiter RCS nozzle cover adhesive, Orbiter TPS, and paints/primers from various sources. Additionally, prelaunch samples of the Orbiter windows and window covers has provided unique source data for the update of the STS debris sample chart. These residual sampling data do not indicate a single source of damaging debris as all of the noted materials have previously been documented in post-landing sample reports. The residual sample data showed no debris trends when compared to previous mission data.

A total of six Post Launch Anomalies, but no In-Flight Anomalies (IFA's), were observed during the STS-72 mission assessment.

2.0 PRE-LAUNCH BRIEFING

The Debris/Ice/TPS and Photographic Analysis Team briefing for launch activities was conducted on 9 January 1996 at 1500 hours. The following personnel participated in various team activities, assisted in the collection and evaluation of data, and contributed to reports contained in this document.

J. Tatum	NASA - KSC	Chief, ET/SRB Mechanical Systems
G. Katnik	NASA - KSC	Shuttle Ice/Debris Systems
J. Lin	NASA - KSC	Shuttle Ice/Debris Systems
B. Davis	NASA - KSC	Digital Imaging Systems
R. Speece	NASA - KSC	Lead, Thermal Protection Systems
B. Bowen	NASA - KSC	Infrared Scanning Systems
J. Rivera	NASA - KSC	Lead, ET Mechanisms/Structures
M. Bassignani	NASA - KSC	ET Mechanisms, Structures
M. Valdivia	LMSO - SPC	Supervisor, ET/SRB Mechanical Systems
R. Seale	LMSO - SPC	ET Mechanical Systems
J. Blue	LMSO - SPC	ET Mechanical Systems
W. Richards	LMSO - SPC	ET Mechanical Systems
M. Wollam	LMSO - SPC	ET Mechanical Systems
G. Fales	LMSO - SPC	ET Mechanical Systems
Z. Byrns	NASA - KSC	Level II Integration
K. Mayer	Rockwell LSS	Systems Integration
W. Atkinson	Rockwell LSS	Systems Integration
M. Eastwood	THIO - LSS	SRM Processing
S. Otto	LMSO - LSS	ET Processing
A. Howard	LMSO - SPC	Safety

3.0 LAUNCH

STS-72 was launched at 96:11:09:41:00.015 GMT (4:41 a.m. local) on 11 January 1996.

3.1 PRE-LAUNCH SSV/PAD DEBRIS INSPECTION

A pre-launch debris inspection of the launch pad and Shuttle vehicle was performed on 10 January 1996. The detailed walkdown of Pad 39B and MLP-1 also included the primary flight elements OV-105 Endeavour (10th flight), ET-75 (LWT 68), and BI-077 SRB's. There were no significant vehicle anomalies. Three untorqued deck bolts at the northeast and northwest corners of the raised deck around the LH SRB exhaust hole were entered into S0007, Appendix K for resolution prior to ET cryogenic loading.

3.2 FINAL INSPECTION

The Final Inspection of the cryoloaded vehicle was performed on 10 January 1996 from to 1100 to 0045 hours during the two hour built-in-hold at T-3 hours in the countdown. There were no Launch Commit Criteria (LCC), OMRS, or NSTS-08303 criteria violations. No IPR's were taken. Due to ambient weather conditions at this time of year, the potential existed for acreage icing. Frost, but no detectable ice, formed on the External Tank. There were no protuberance icing conditions outside of the established data base.

A portable Shuttle Thermal Imager (STI) infrared scanning radiometer was utilized to obtain vehicle surface temperature measurements for an overall thermal assessment of the vehicle, particularly those areas not visible from remote fixed scanners, and to scan for unusual temperature gradients (Figures 1 and 2).

3.2.1 ORBITER

No Orbiter tile or RCC panel anomalies were observed. The R2U, L3D, L4D, and L4L RCS thruster covers were tinted green indicating small internal vapor leaks. Ice/frost accumulations and condensate were present along the full 360 degree circumference of the SSME #1 and #2 heat shield-to-nozzle interfaces. An infrared scan revealed no unusual temperature gradients on the base heat shield or engine mounted heat shields.

3.2.2 SOLID ROCKET BOOSTERS

SRB case temperatures measured by the STI radiometer were averaging 45-54 degrees F depending on the wind direction. Temperatures measured by the SRB Ground Environment Instrumentation (GEI) ranged from 51-56 degrees F. All measured temperatures were above the 34 degrees F minimum requirement. The predicted Propellant Mean Bulk Temperature (PMBT) supplied by THIO was 54 degrees F, which was within the required range of 44-86 degrees F.

3.2.3 EXTERNAL TANK

The ice/frost prediction computer program 'SURFICE' was run from 2000 to 0430 hours and the results tabulated in Figure 3. The program predicted ET surface temperatures dropping below 32 degrees Fahrenheit and the formation of ice on most areas of the TPS acreage, with the exception of the LO2 tank ogive, during cryoload.

However, the Final Inspection Team observed dry TPS on the LO2 tank ogive. Very light condensate and frost, but no detectable ice, accumulated on the LO2 tank barrel +Y+Z quadrant. There were no TPS anomalies. The portable STI measured surface temperatures as high as the mid-40's on the ogive and an average temperature of 29 degrees F (frosted areas) on the barrel. Similar readings were taken by the Raytek handheld spot radiometer. SURFICE predicted temperatures of 31 degrees F on the ogive and 27 degrees on the barrel at the time of the inspection.

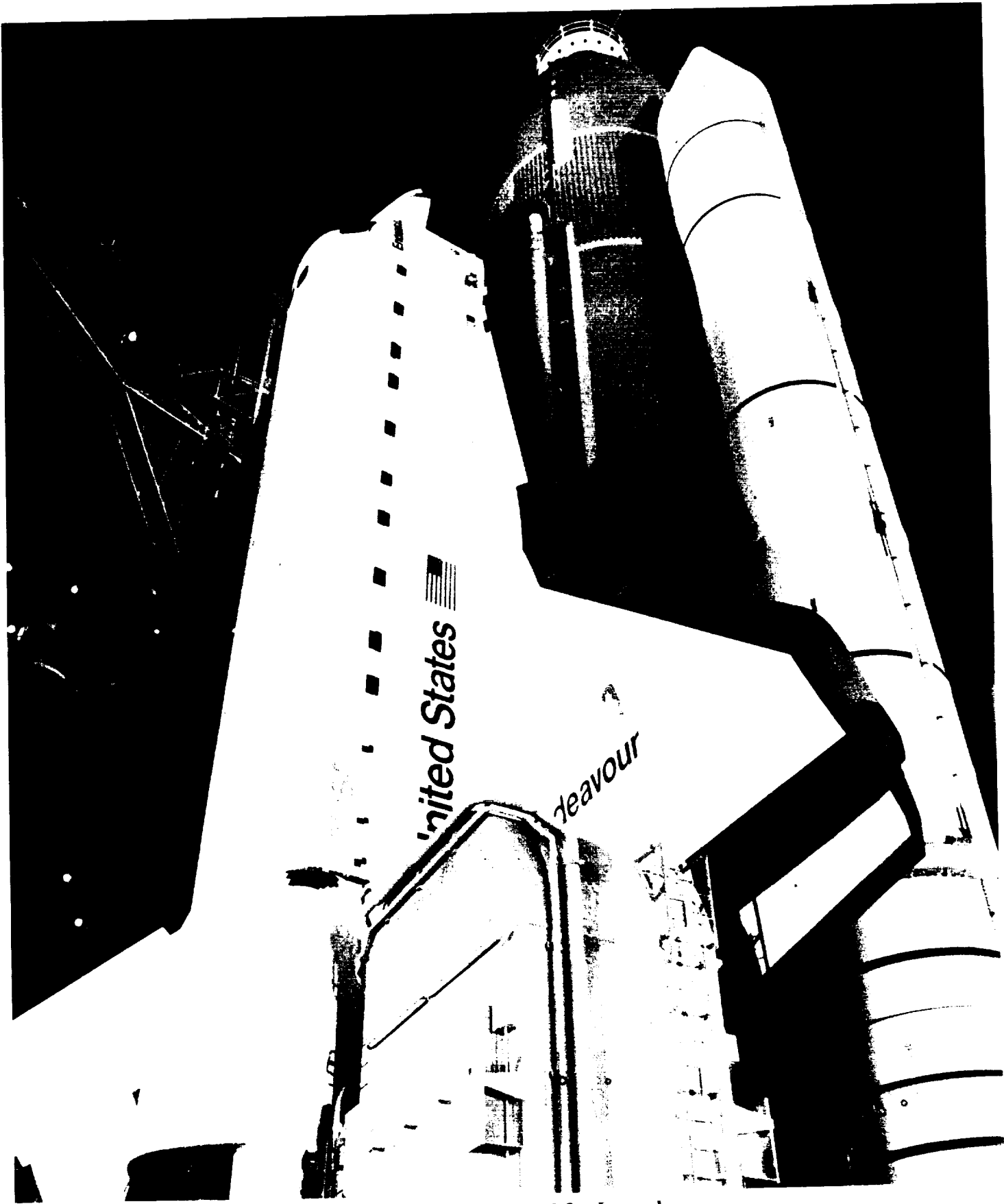
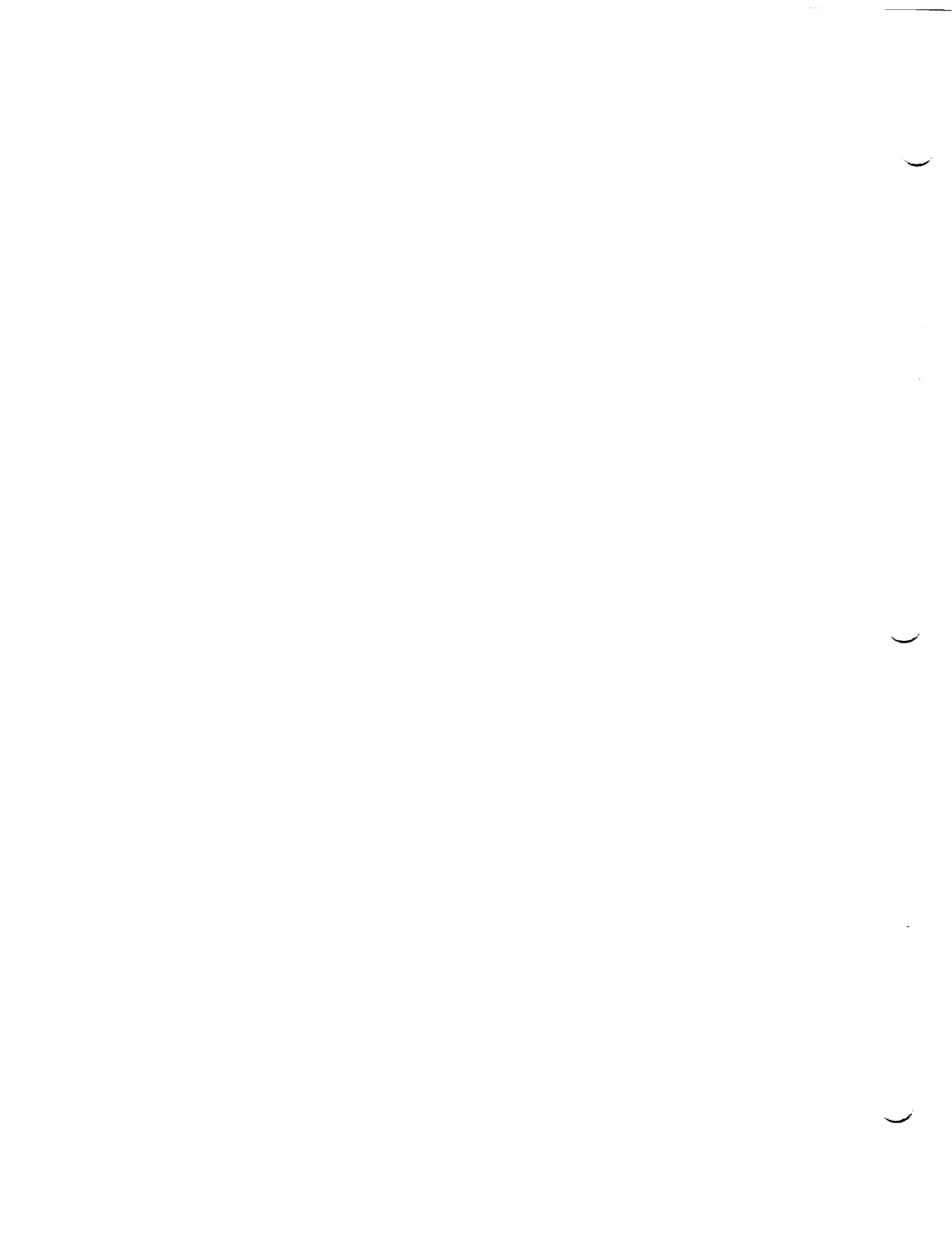

Photo 2: ET-75 Cryoloaded for Launch

The Final Inspection Team observed dry TPS on the LO2 tank ogive. Very light condensate and frost, but no detectable ice, had accumulated on the LO2 tank barrel and LH2 tank acreage +Y+Z quadrant.



SSV INFRARED SCANNER SURFACE TEMPERATURE SUMMARY DATA

TIME: 1100-0045
 DATE: 1-11-96
 VEH. STS- 72

All temperatures are
in degrees Fahrenheit

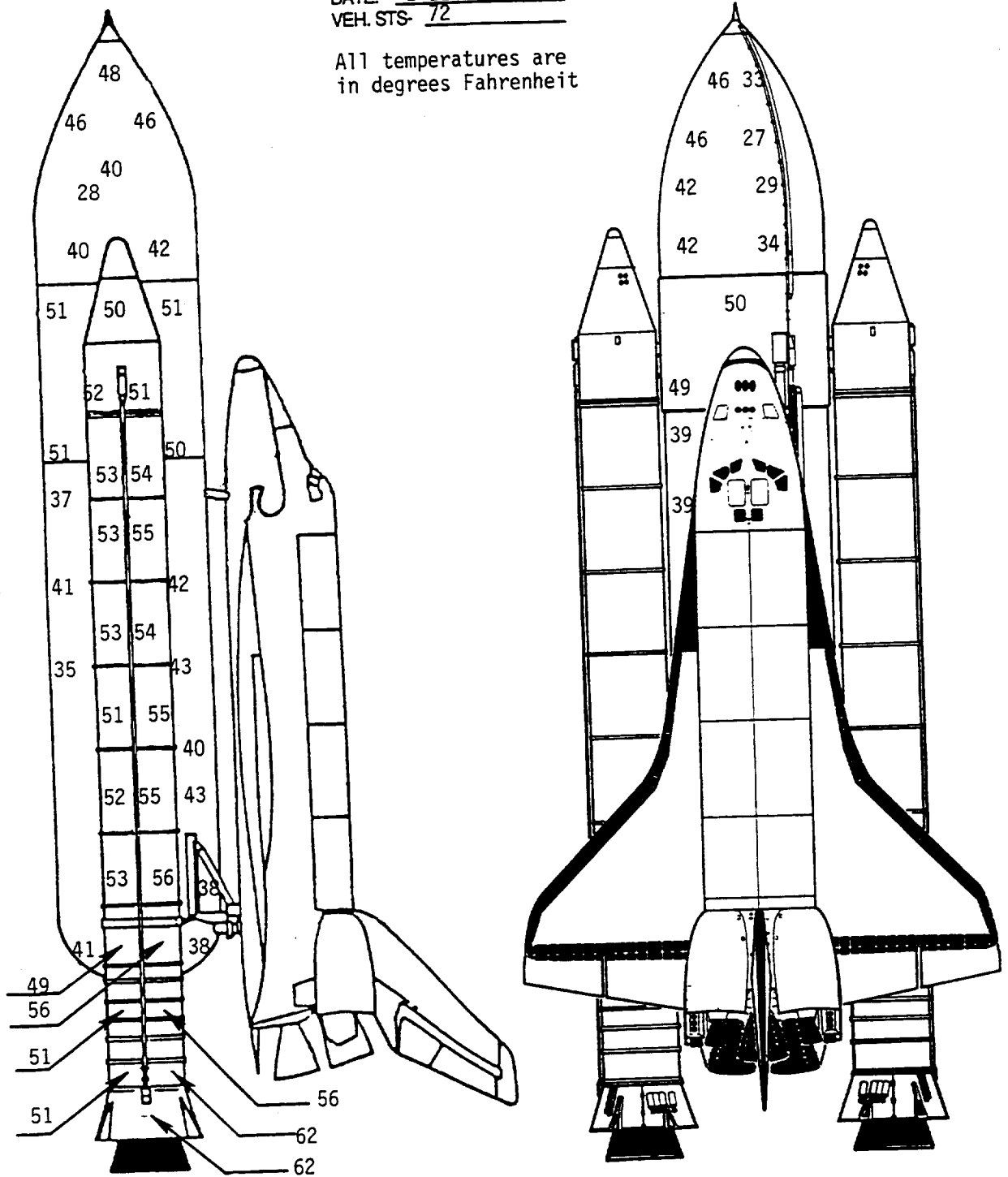

Figure 1: Vehicle Surface Temperature STI Measurements

SSV INFRARED SCANNER SURFACE TEMPERATURE SUMMARY DATA

TIME: 1100-0045
 DATE: 1/11/96
 VEH. STS: 72

All temperatures are
 in degrees Fahrenheit

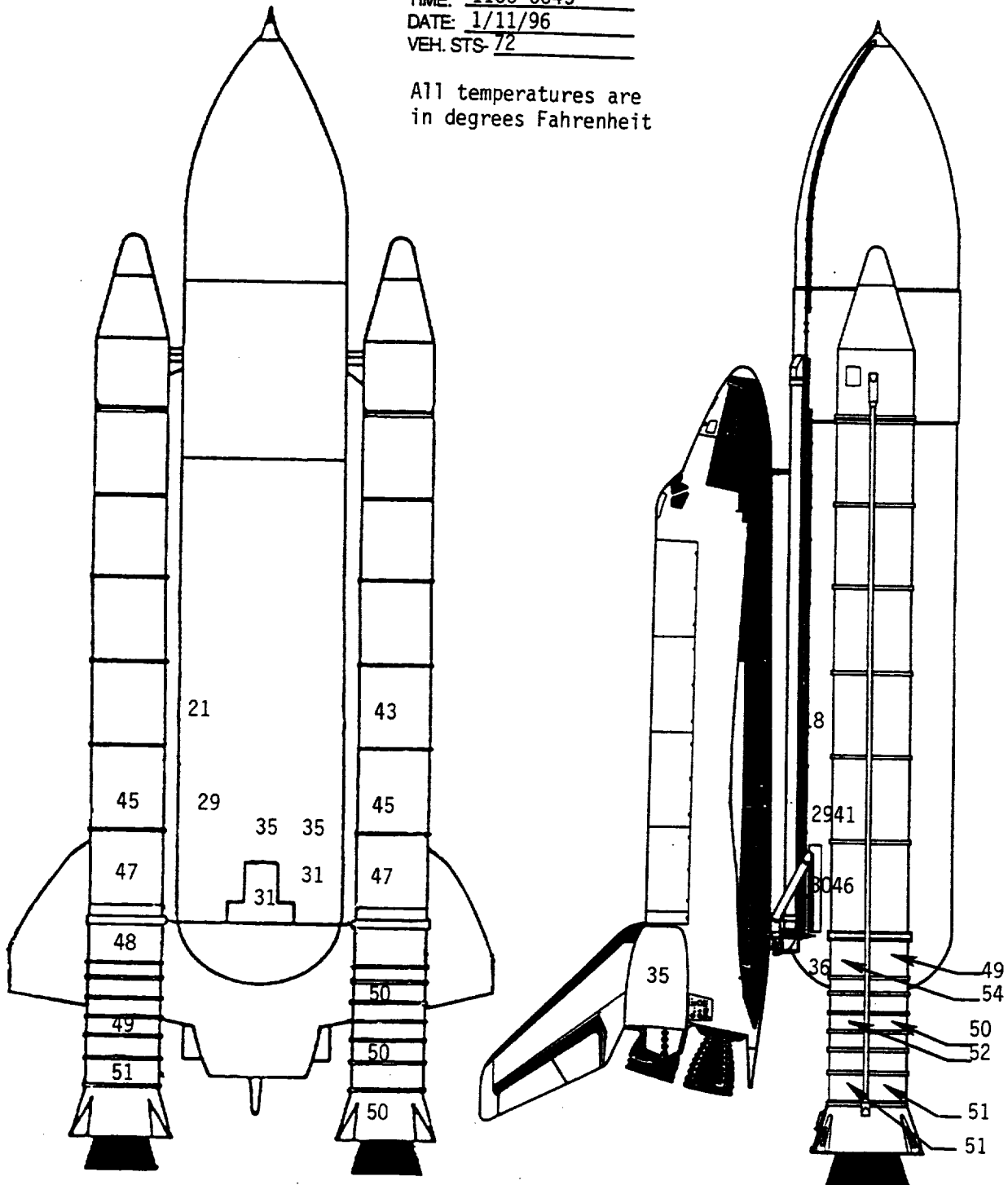

Figure 2: Vehicle Surface Temperature STI Measurements

The intertank acreage exhibited no TPS anomalies. Less than usual ice/frost accumulation was present on the GUCP and the ET umbilical carrier plate. The portable STI and Raytek measured an average surface temperature of 50 degrees F on the intertank.

There were no LH2 tank TPS acreage anomalies. Very light condensate and frost, but no detectable ice accumulation, was present on the acreage. Most of the frost had formed in the +Y+Z quadrant. A large, localized patch of thick frost was visible in the +Y-Z quadrant. Most of the frost in the -Y-Z quadrant had disappeared by the end of the inspection. The portable STI measured surface temperatures that averaged 40 degrees F on the upper LH2 tank. The lower LH2 tank was generally 30 degrees F with the exception of the frost covered areas, which measured 21 degrees. SURFICE predicted temperatures of 23 degrees F on the upper tank and 33 degrees on the lower tank. Frost had formed along the PAL, pressurization line, and cable tray ramp-to-acreage interfaces. The aft dome and manhole cover closeouts were dry.

There were no anomalies on the new-method bipod jack pad closeouts. A 10-inch long by 3/8-inch wide crack on the -Y ET/SRB cable tray forward surface TPS was acceptable for flight per the NSTS-08303 criteria.

Typical amounts of ice/frost had accumulated in the LO2 feedline bellows and support brackets.

There were no TPS anomalies on the LO2 ET/ORB umbilical. Ice/frost fingers on the separation bolt pyrotechnic canister purge vents were typical.

Ice and frost in the LH2 recirculation line bellows and on both burst disks, and in the LH2 feedline bellows was expected given the ambient weather conditions.

Typical amounts of ice/frost had accumulated on the LH2 ET/ORB umbilical purge barrier top and outboard sides. Typical ice/frost fingers were present on the pyro canister and plate gap purge vents. Ice/frost had formed on the forward pyro canister closeout bondline. No unusual vapors or cryogenic drips had appeared during tanking, stable replenish, and launch.

The summary of Ice/Frost Team observations/anomalies, which were all acceptable for launch per the NSTS-08303 criteria, consisted of four OTV recorded items.

3.2.4 FACILITY

All SRB sound suppression water troughs were filled and properly configured for launch (LCC requirement).

No leaks were observed on the GUCP or either of the LO2 and LH2 Orbiter T-0 umbilicals.

Three loose bolts under the raised deck at the northeast and northwest corners of the LH SRB exhaust hole were untorqued.

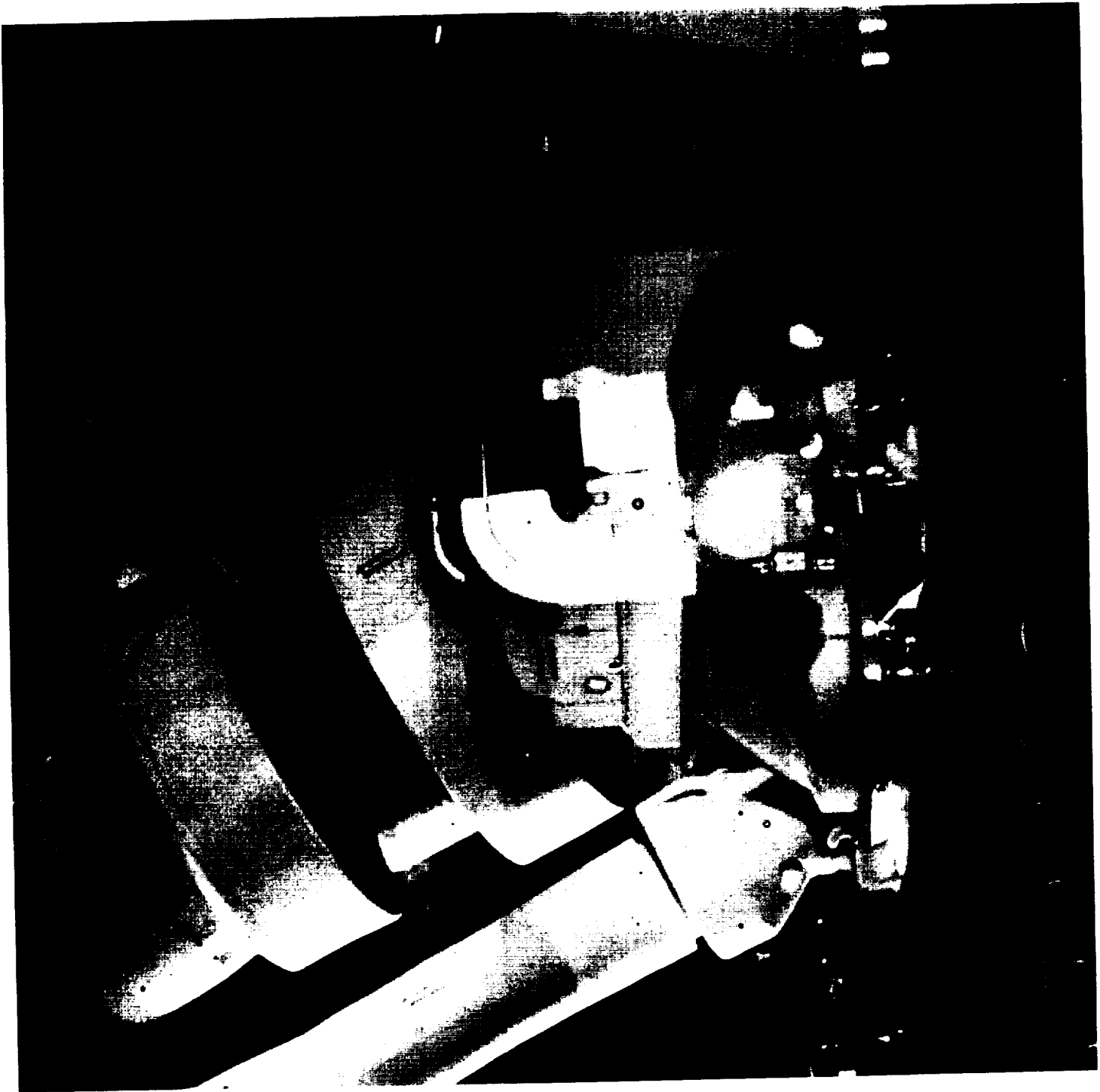

Photo 3: ET/ORB LH2 Umbilical

Less than usual amounts of ice/frost had accumulated on the LH2 ET/ORB umbilical purge barrier top and outboard sides. Typical ice/frost fingers were present on the pyro canister and plate gap purge vents. No unusual vapors or cryogenic drips had appeared during tanking, stable replenish, and launch.



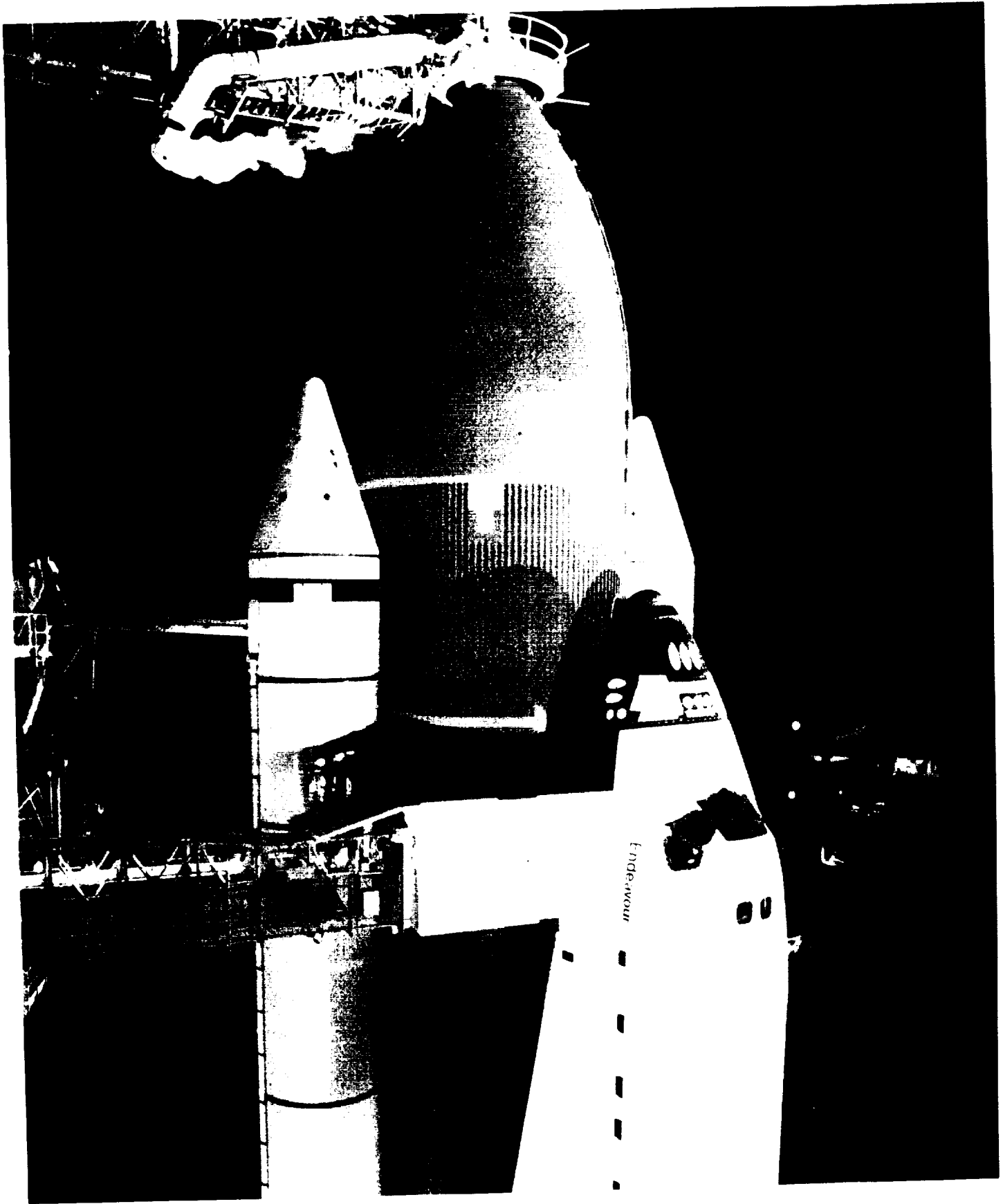
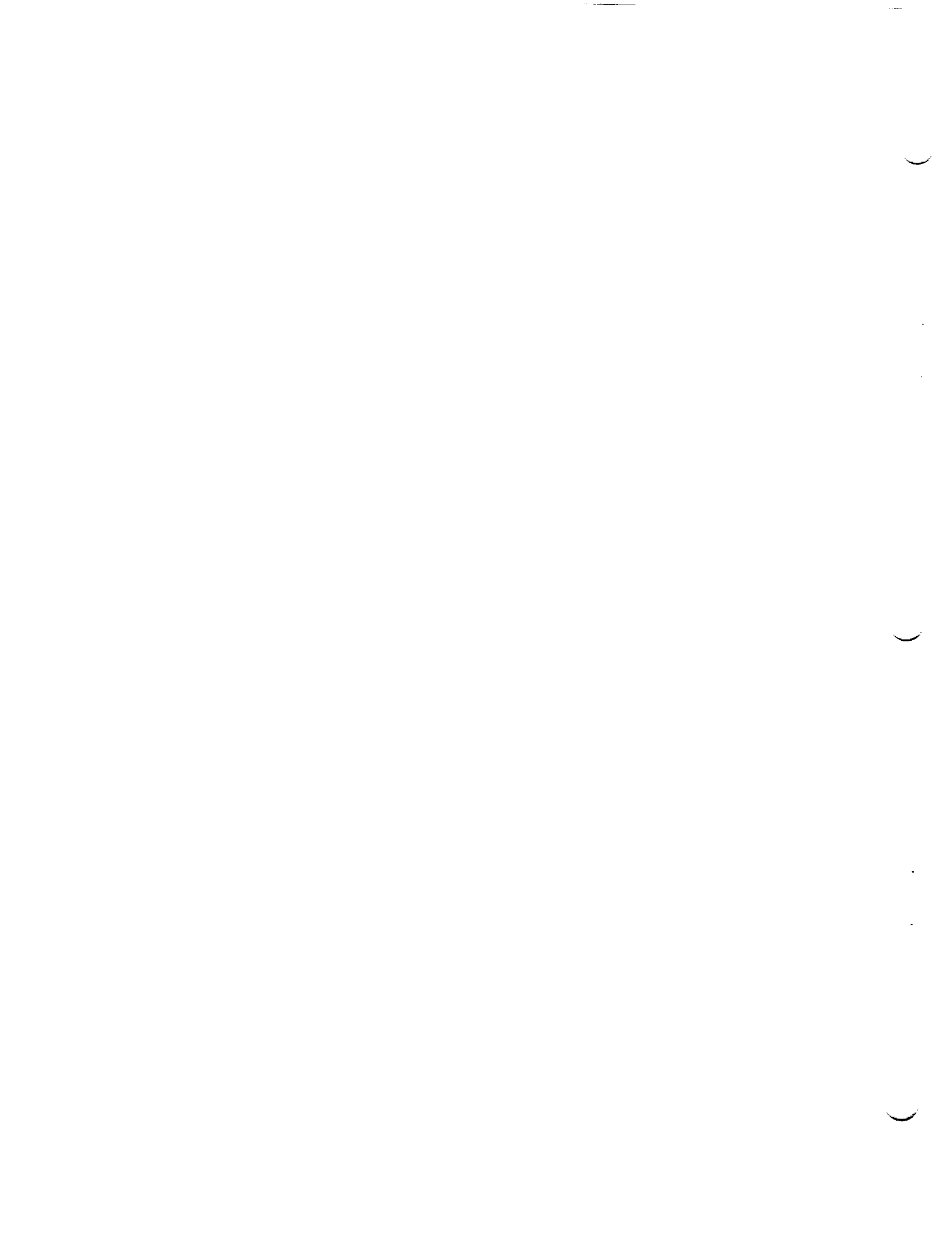

Photo 4: ET Intertank and LO2 Tank Barrel After Cryoload

The intertank acreage exhibited no TPS anomalies. The portable STI and Raytek measured an average surface temperature of 50 degrees F on the intertank. Very light condensate and frost, but no detectable ice, accumulated on the LO2 tank barrel +Y+Z quadrant.



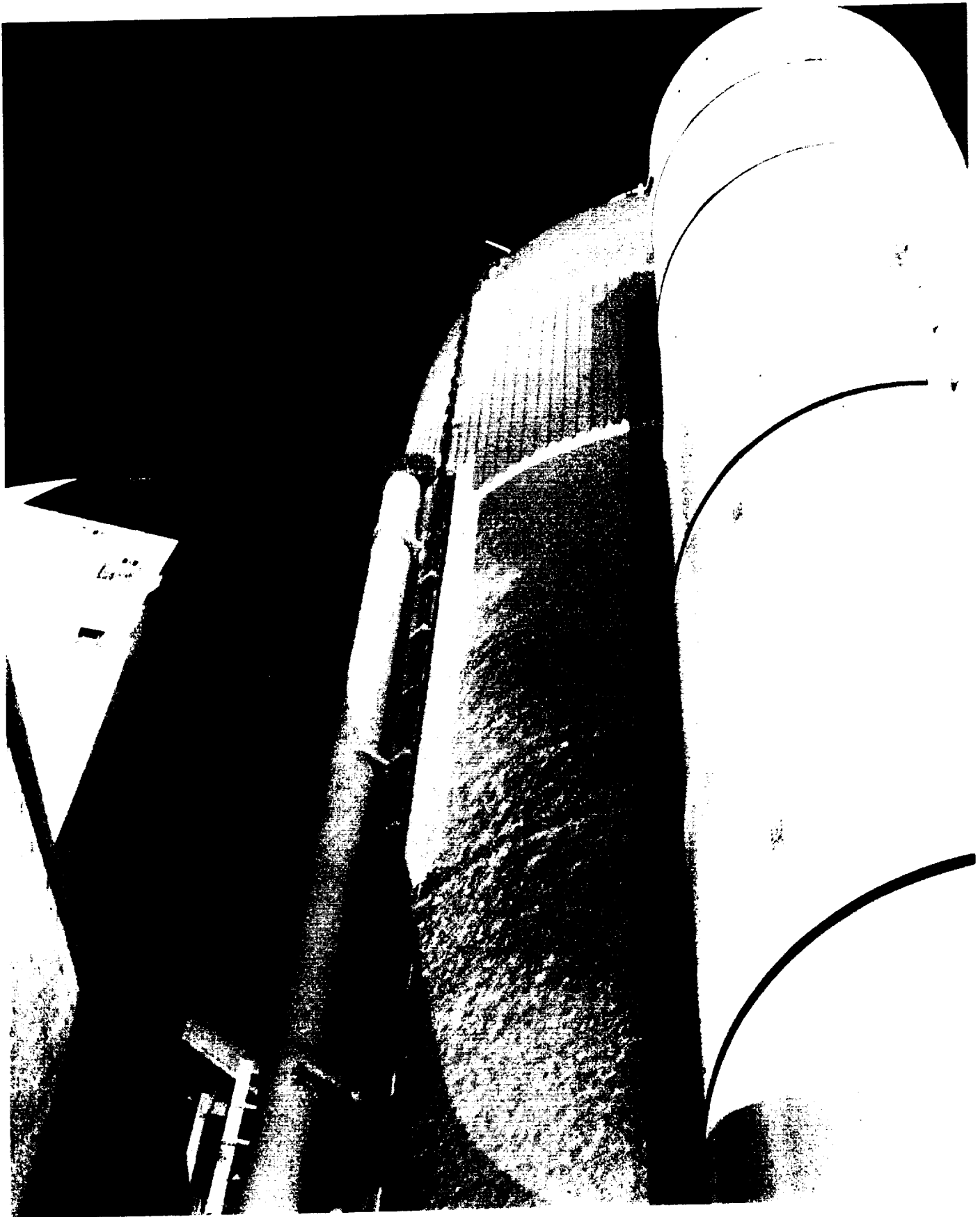

Photo 5: LH2 Tank +Y+Z Quadrant

There were no LH2 tank TPS anomalies. Very light condensate and frost, but no detectable ice accumulation, was present on the acreage. Most of the frost had formed in the +Y+Z quadrant.



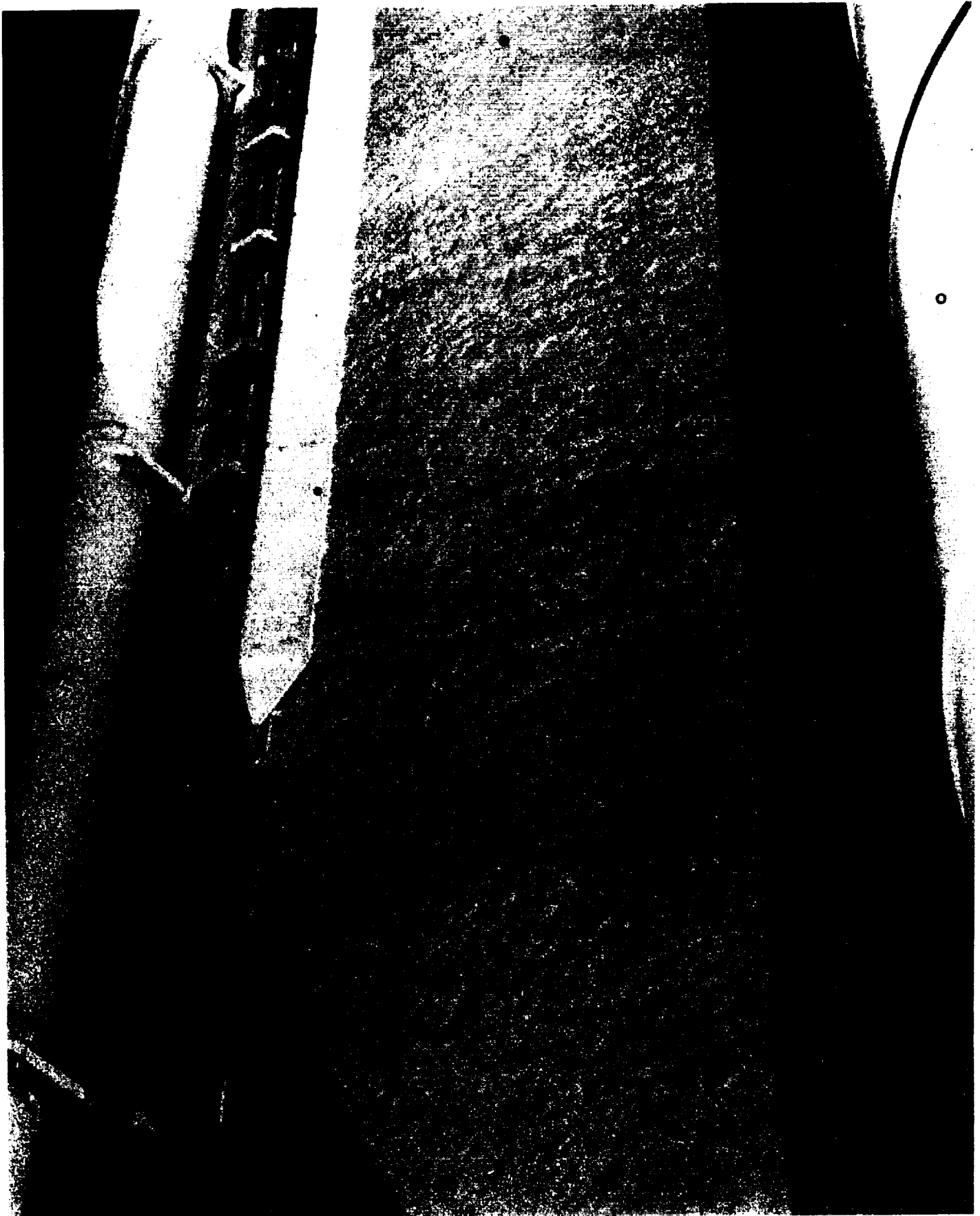
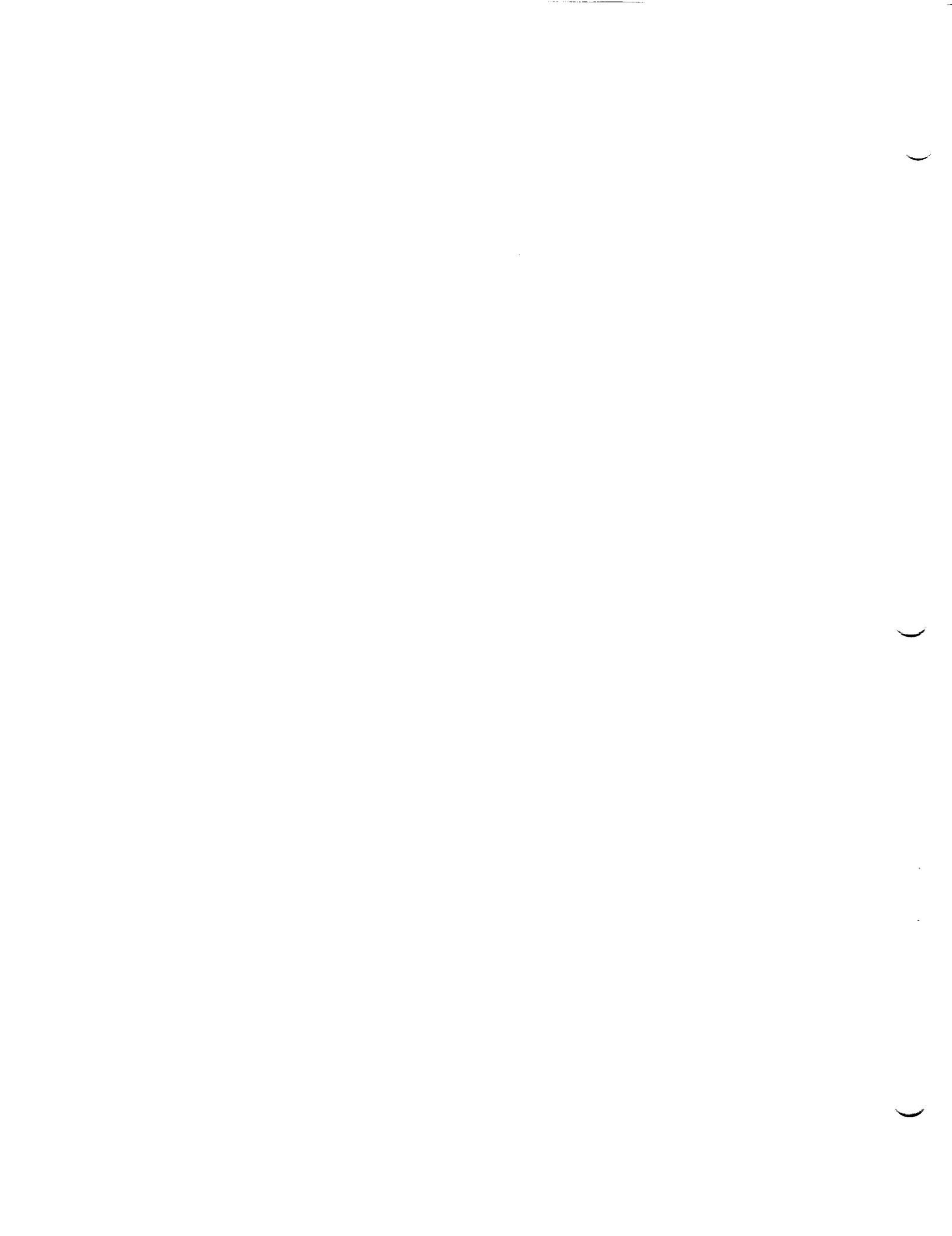

Photo 6: Overall View of LH2 Tank

Typical amounts of ice/frost had accumulated in the LO2 feedline bellows and support brackets. Very light condensate and frost, but no detectable ice accumulation, was present on the acreage.



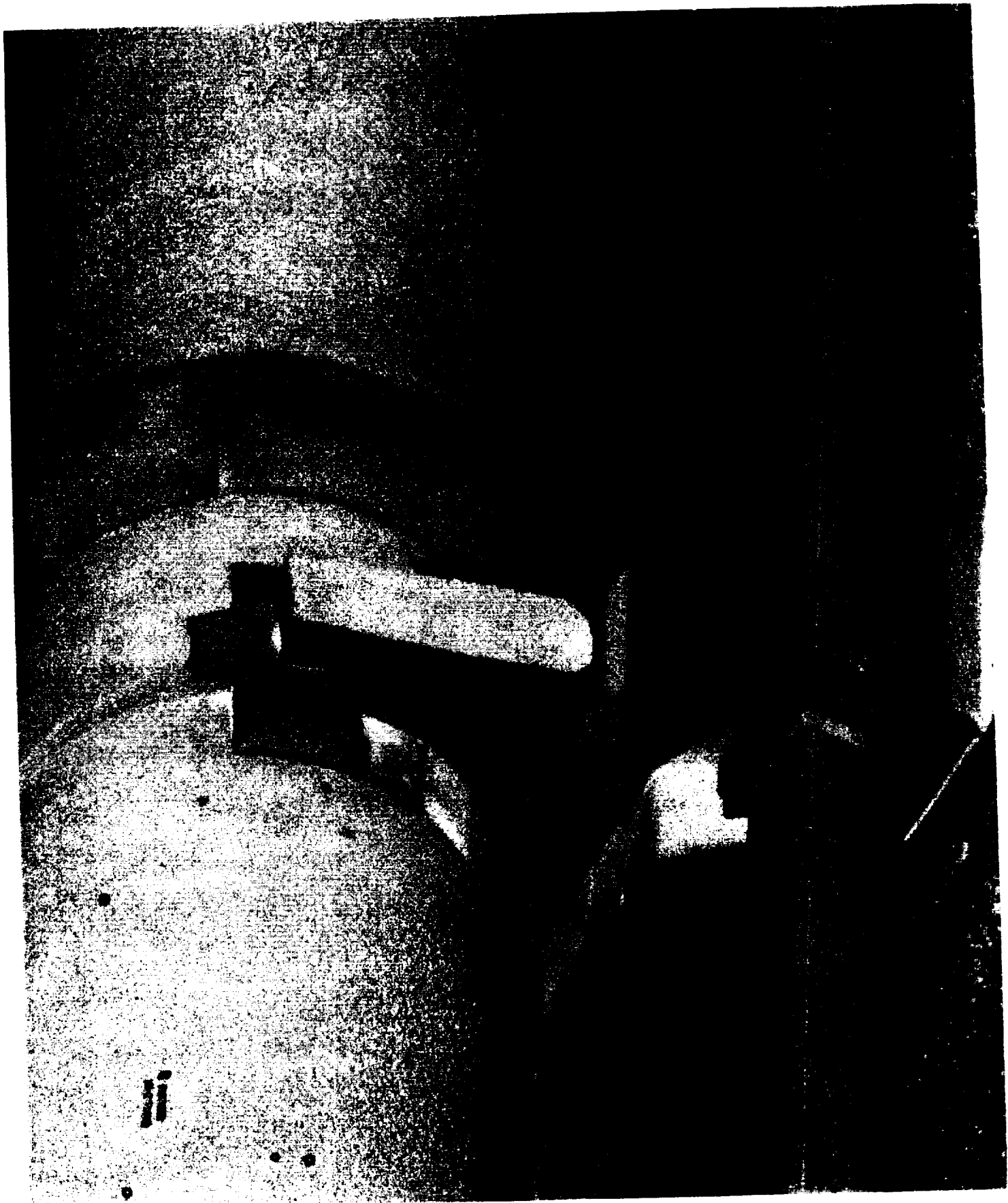

Photo 7: LO2 Feedline Bellows and Support Brackets

Typical amounts of ice/frost had accumulated in the LO2 feedline bellows and support brackets.

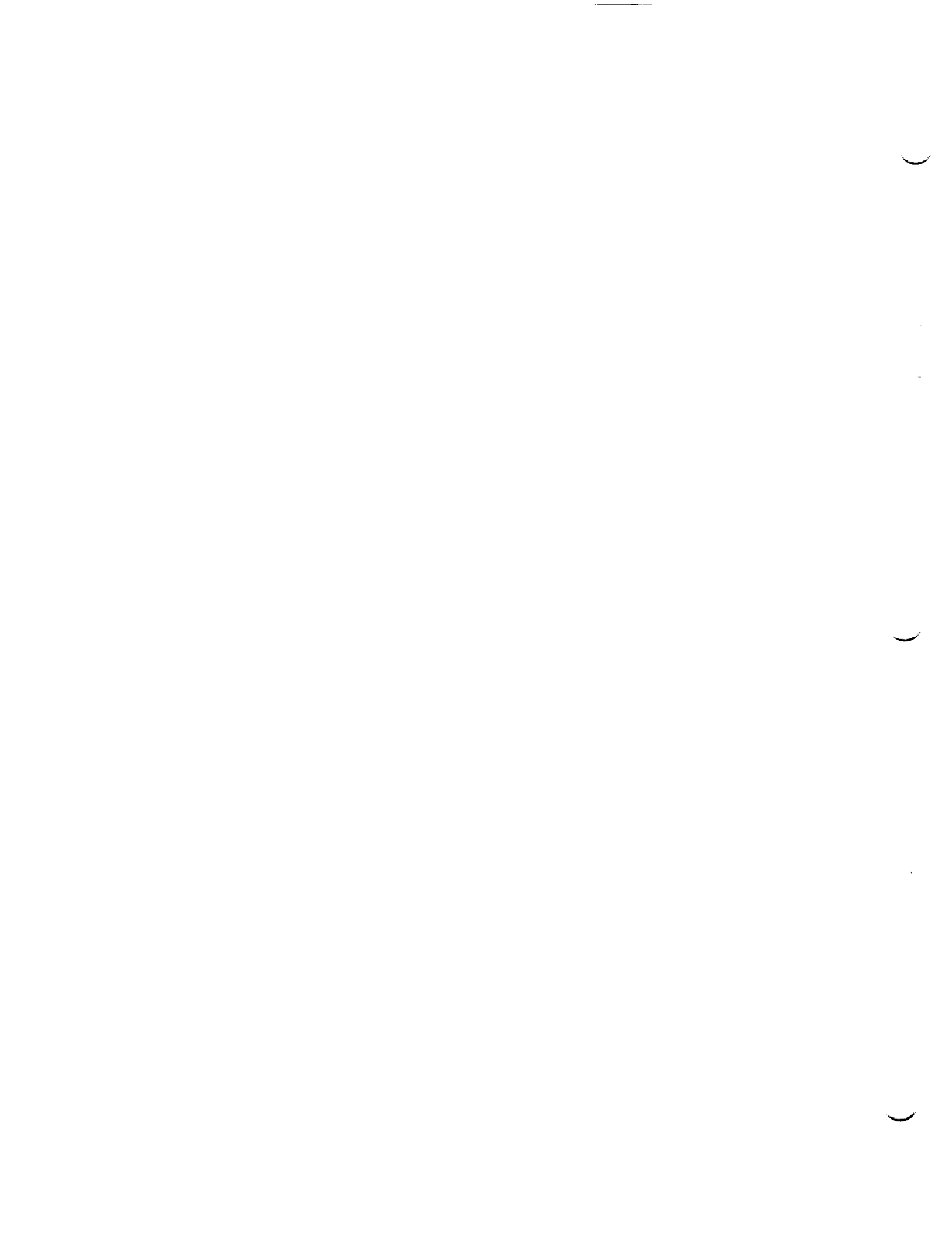



Photo 8: Overall View of GUCP

Less than usual ice/frost accumulation was present on the GUCP and the ET umbilical carrier plate. No leaks were observed on the GUCP.

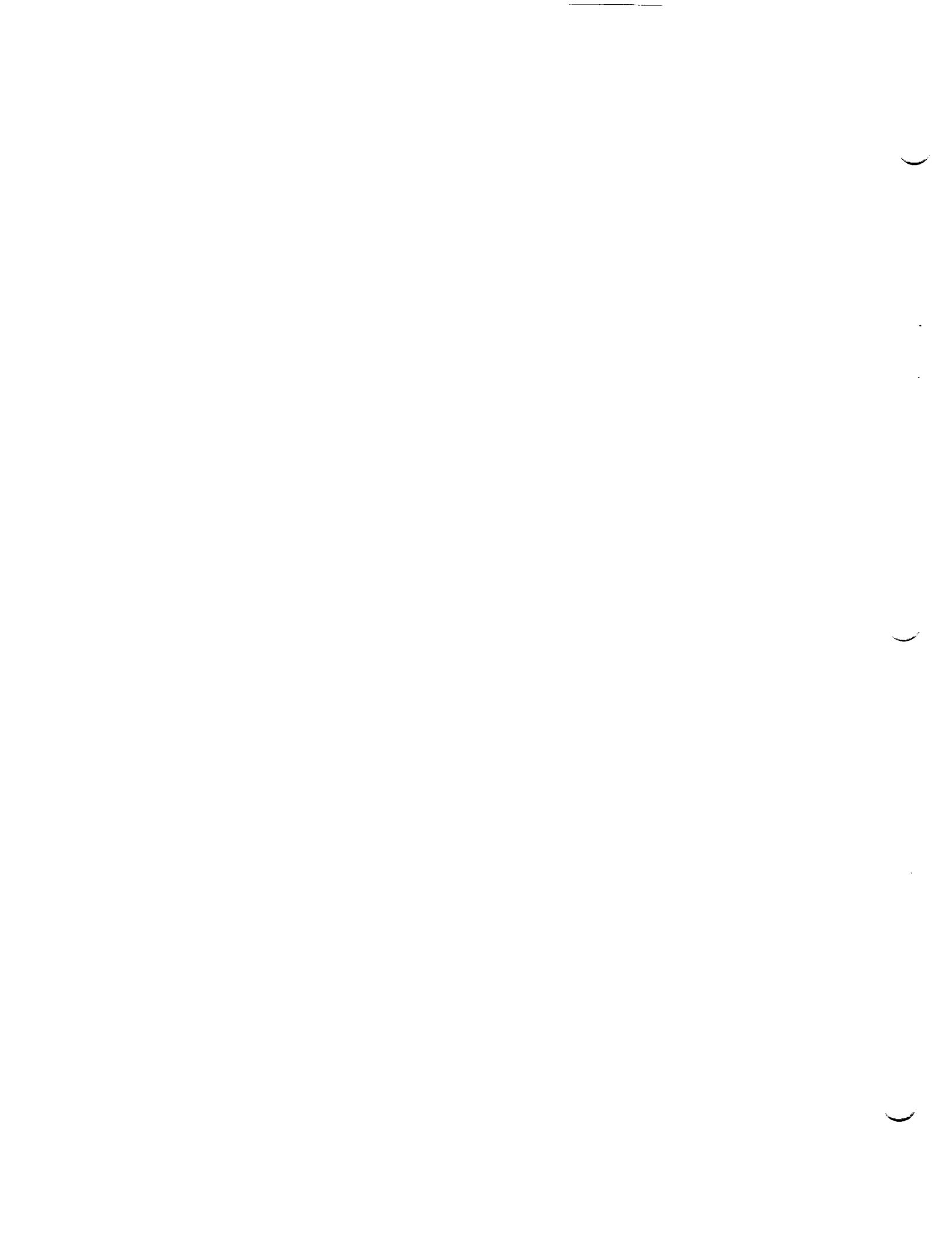
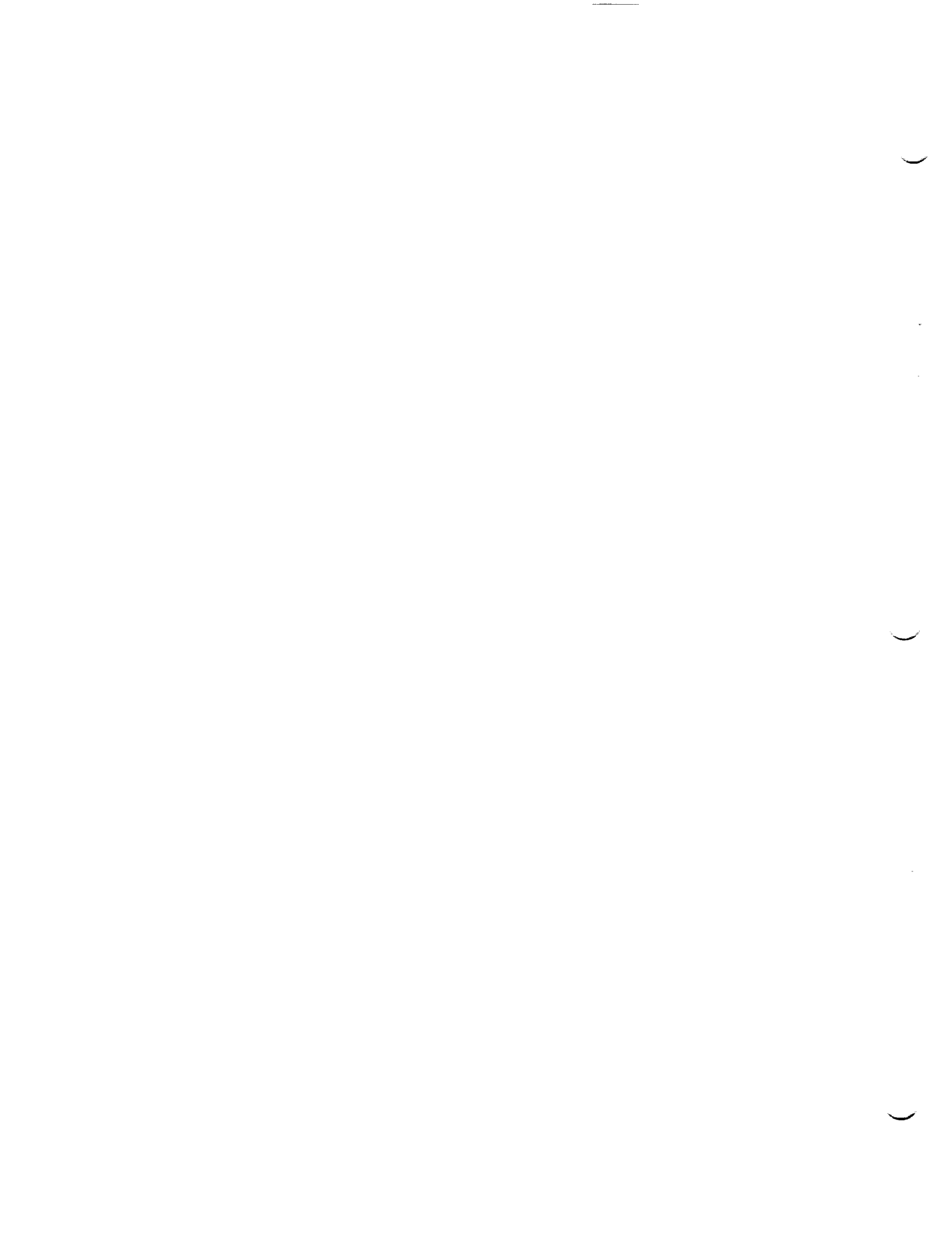



Photo 9: Lower Quarter View of Hydrogen Vent QD

Less than usual ice/frost accumulation was present on the GUCP and the ET umbilical carrier plate.



4.0 POST LAUNCH PAD DEBRIS INSPECTION

The post launch inspection of the MLP, FSS, RSS, and Pad B apron/crawlerway/acreage was performed for two hours on 11 January 1996 starting at Launch + 2 hours.

South SRB HDP erosion was typical. All south HDP shoe EPON shim material was intact. Rockwell-Downey reported a 0.08g lateral acceleration at liftoff and no stud hang-ups were expected. All of the north HDP doghouse blast covers were in the closed position. Erosion of the blast covers was typical. Minor damage to the SRB aft skirt purge lines and T-0 umbilicals was similar to previous launches.

The Tail Service Masts (TSM), Orbiter Access Arm (OAA), and GOX vent hood appeared undamaged. One small area of ET nose cone topcoat, approximately 1-inch long by 0.5-inches wide, adhered to the surface of the northeast GOX seal. Missing topcoat from the GOX seal footprint area is acceptable for flight.

The GH2 vent line had no loose cables (static retract lanyard), and appeared to have latched properly with no rebound. The GUCP legs and crossbeam showed no obvious signs of contact by the static retract lanyard. The vent line was latched on the sixth tooth of the latching mechanism. The RSS cable had disconnected properly.

Typical pad damage included:

- Five foot long crack in the MLP deck plating north of the LH SRB exhaust hole

- Untorqued bolts under the raised deck at the northeast and northwest corners of the LH SRB exhaust hole. These bolts had been identified during the pre-launch pad inspection.

- Missing access cover and broken cable tray bracket on FSS 135 foot level

- Loose cable tray covers and brackets on FSS 255 foot level

Overall, damage to the pad appeared minimal.

Post launch pad inspection anomalies are listed in Section 9.

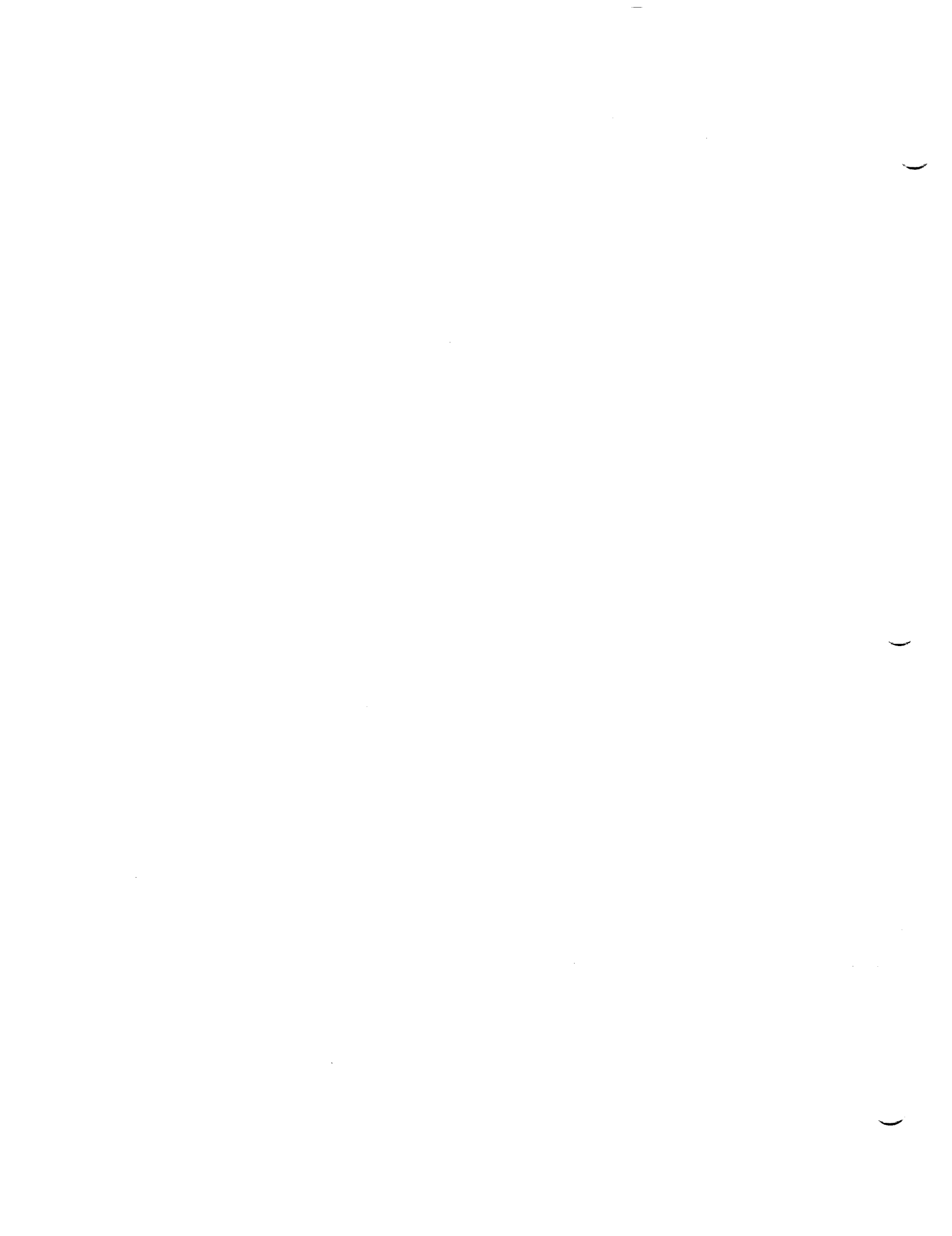

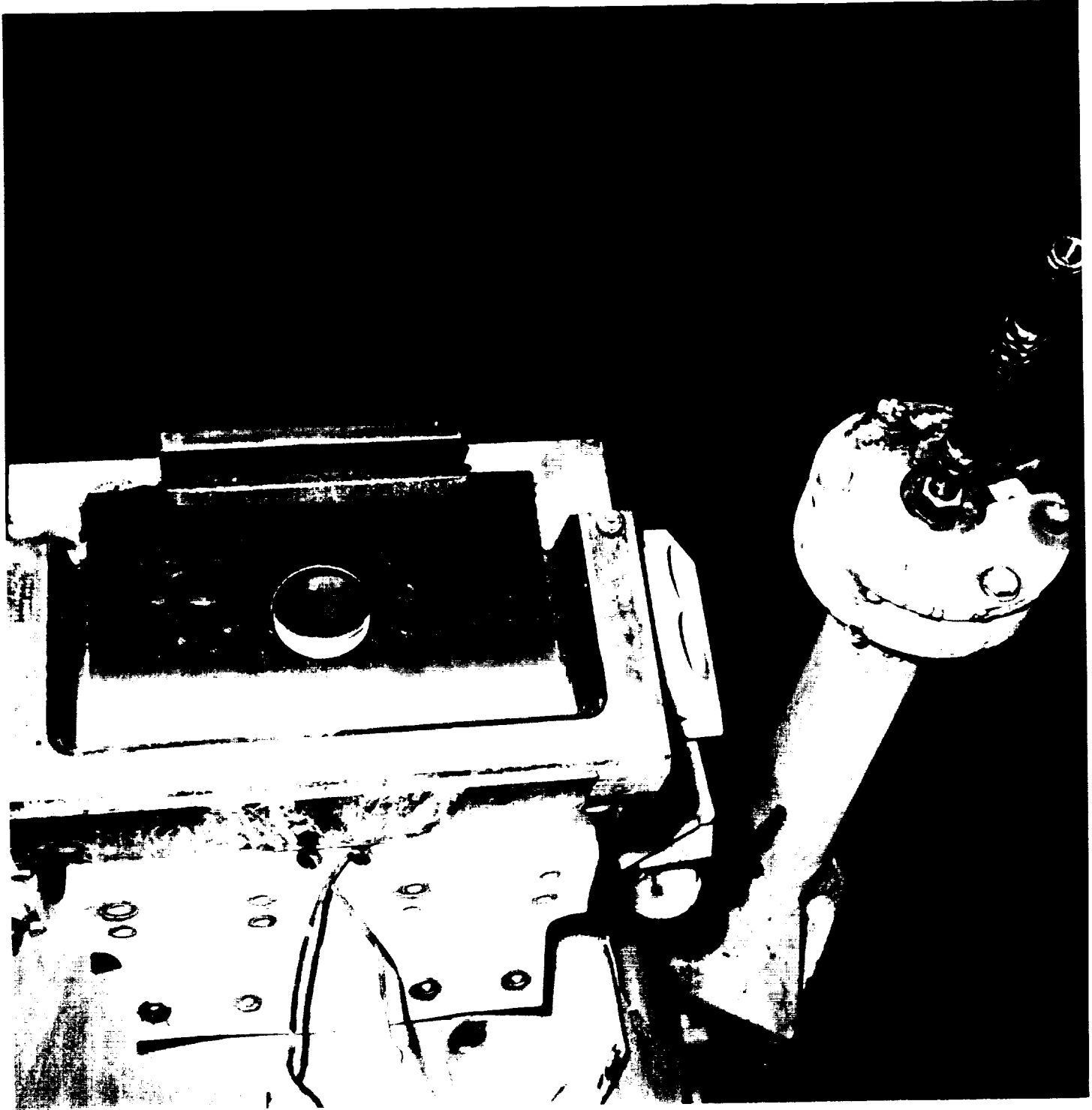

Photo 10: Aft Skirt Shoe Shim

Although the aft skirt shoe shim material was intact, the new material, which is somewhat darker than the material used prior to BI-074, exhibited a bubbled appearance after launch



5.0 FILM REVIEW

Anomalies observed in the Film Review were presented to the Mission Management Team, Shuttle managers, and vehicle systems engineers. No IPR's or IFA's were generated as a result of the film review. Post flight anomalies are listed in Section 9.

5.1 LAUNCH FILM AND VIDEO SUMMARY

A total of 100 films and videos, which included thirty-eight 16mm films, nineteen 35mm films, four 70mm films, and thirty-nine videos, were reviewed starting on launch day.

Free burning hydrogen had drifted upward to the base heat shield and OMS pods during start-up. SSME ignition and Mach diamond formation appeared normal. An intact paper cover from a downward firing RH RCS thruster came loose and fell aft past SSME #3 at liftoff (OTV 151, 170, 171).

Small pieces of tile surface coating material were lost from 2 places on the base heat shield near SSME #2 (E-17), 1 place on the base heat shield near the T-0 disconnect (E-17), and 5 places on the base heat shield near the SSME's (E-20).

SSME ignition caused pieces of ice to fall from the ET/ORB umbilicals. The ice finger from the upper plate gap purge vent shook loose, deflected off the LH2 ET/ORB umbilical cable tray clam shell, and contacted Orbiter tiles below the umbilical cavity. No tile damage was visible as a result of the impact (OTV 109).

Ice fell from the ET LO2 feedline upper bellows, but did not contact Orbiter tiles (E-54).

A rectangular object, believed to be a base heat shield gap filler, first appeared from an area behind the body flap in the general vicinity of SSME #2 and fell aft at GMT 09:40:57.671 (E-17).

No stud hang-ups occurred on any of the holddown posts. No ordnance fragments or frangible nut pieces fell from any of the DCS/stud holes.

The Orbiter LH2 and LO2 T-0 umbilicals disconnected and retracted properly (OTV 149, 150, 170, 171). As the LH2 T-0 umbilical carrier plate retracted, a rectangular object 1.5-inches long by 1-inch wide appeared to originate from the umbilical plate cable area and fall past the Orbiter inboard elevon at 09:41:00.357 GMT. The object is most likely a metal parts tag from the carrier plate flex lines. No contact with Orbiter tiles was detected (E-18, -31). A piece of the LH2 TSM purge barrier dangled from the TSM door cavity at T-0 (E-2, -19).

GUCP disconnect from the ET was nominal. GH2 vent line retraction and latch were normal. Slack in the static retract lanyard was typical (E-33, -41, -50).

Movement of the GOX vent hood in the SRB plume after the vehicle cleared the tower appeared to be similar to previous launches and resulted in no unusual damage (E-62).

Several pieces of light-colored debris, most likely chunks of instafoam from the SRB aft skirts, fell out of the SRB plume after the roll maneuver (E-54, -57, -59).

A flare, or long streak, was visible in the SSME plume during ascent at T+22 seconds MET (ET-212; E-218, -220).

Body flap movement (amplitude and frequency) appeared similar to previous flights (E-220). ET aft dome charring, exhaust plume recirculation, and SRB separation appeared nominal.

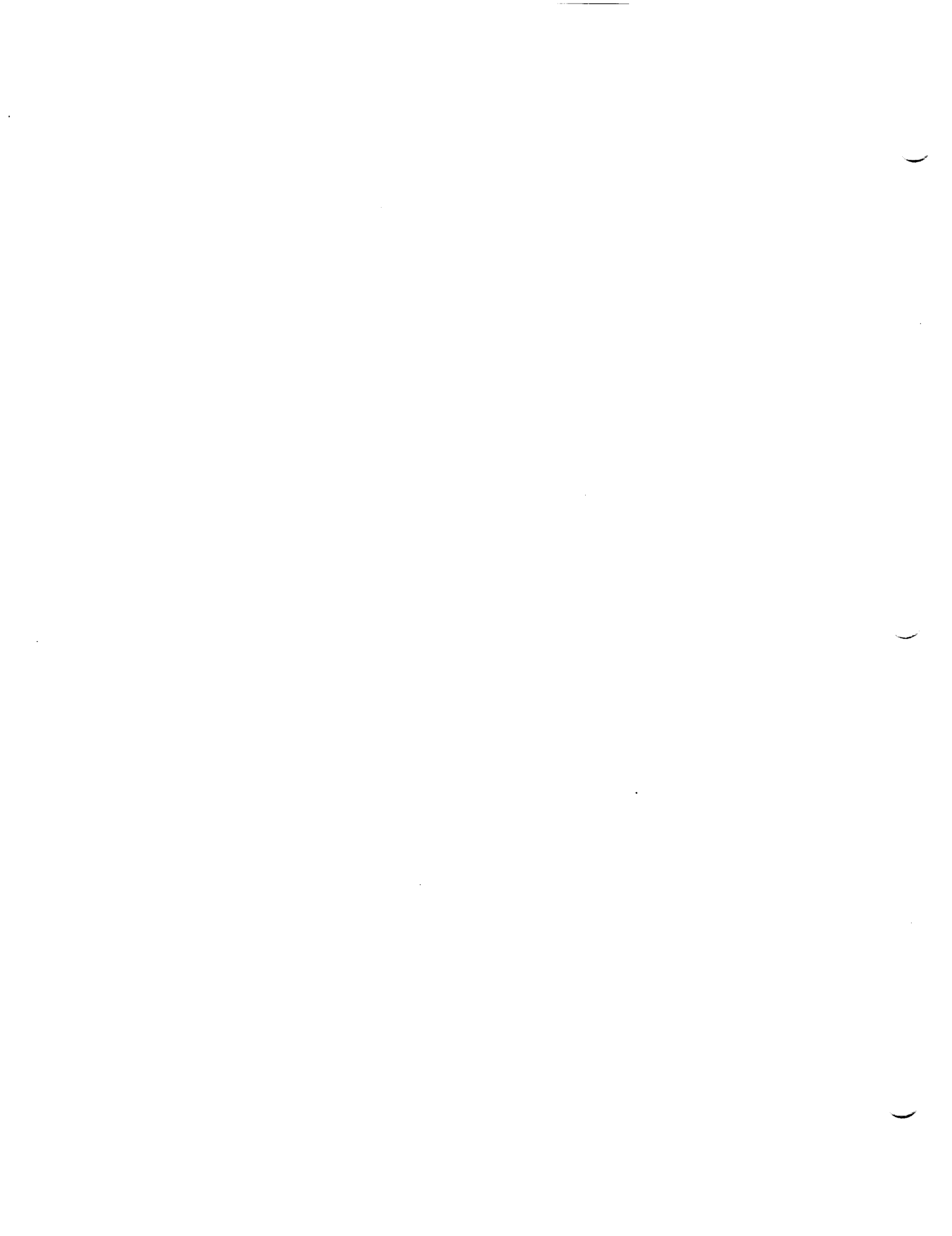

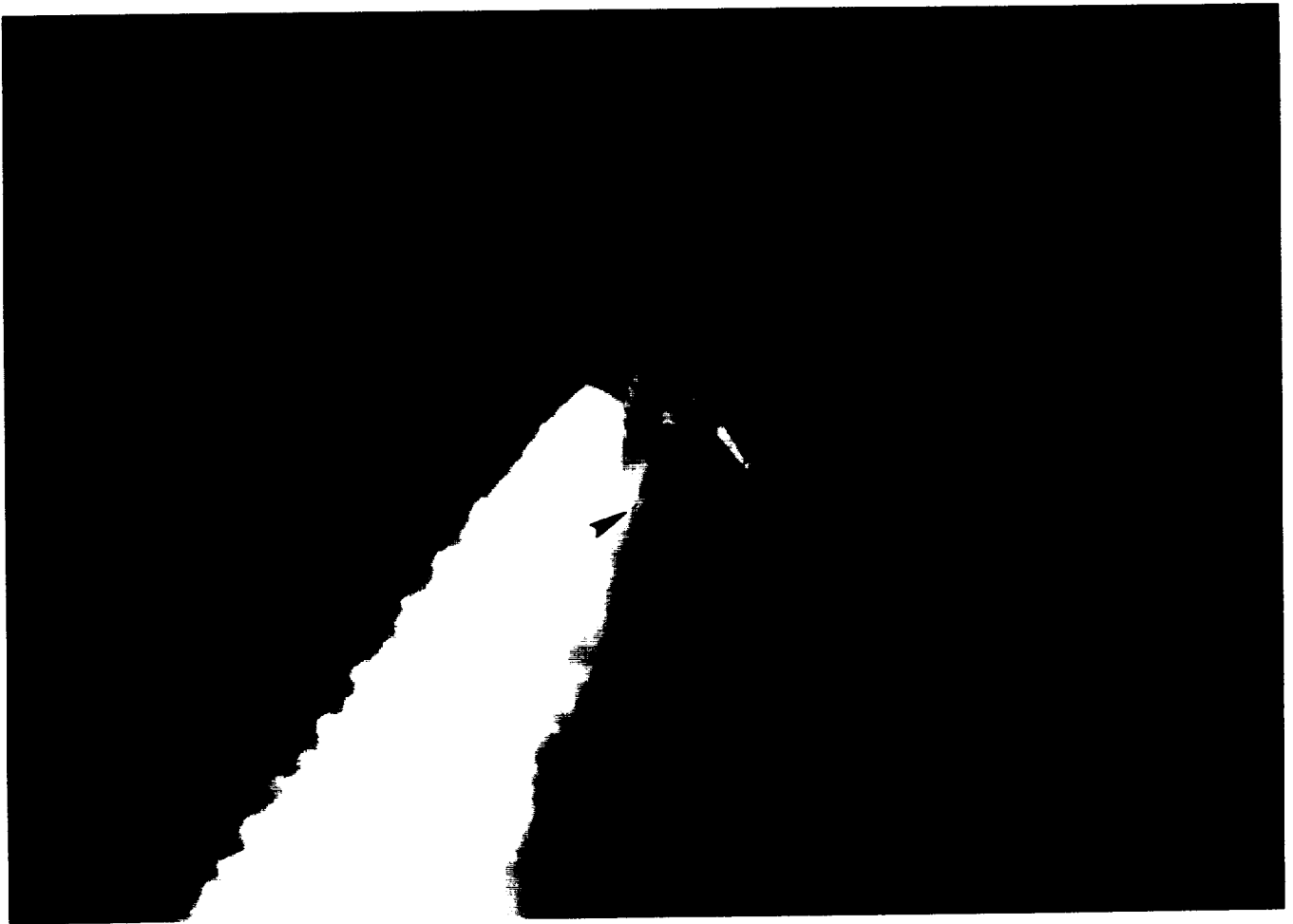
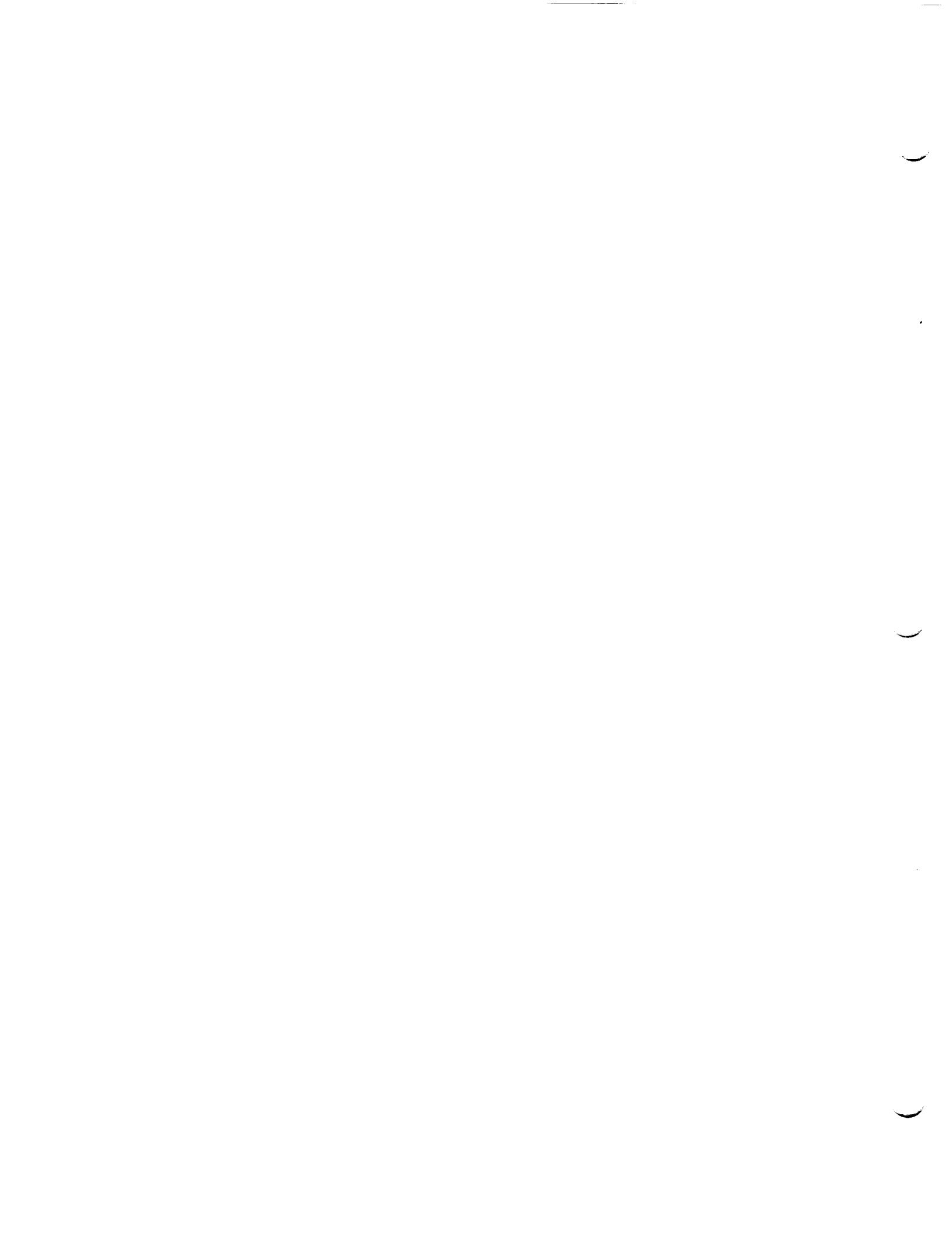

Photo 11: Flame in Engine Plume

A flare, or long streak, was visible in the SSME plume during ascent at T+22 seconds MET



5.2 ON-ORBIT FILM AND VIDEO SUMMARY

OV-105 was equipped to carry umbilical cameras: 16mm motion picture with 5 mm lens; 16mm motion picture with 10mm lens; 35mm still views. Data was obtained from two cameras (the 35mm camera malfunctioned) along with hand held photography by the flight crew (eleven still photos and video footage). The umbilical films were hampered by the lack of light for ET separation.

No vehicle damage or lost flight hardware was observed that would have been a safety of flight concern.

SRB separation from the External Tank was nominal.

ET-75 separation from the Orbiter was nominal. The BSM burn scars on the LO2 tank were typical. No anomalies were observed on the nosecone, PAL ramps, and LO2 feedline. Likewise, no -Z side acreage TPS anomalies were detected on the LO2 tank, intertank, and LH2 barrel.

The LH2 ET/ORB umbilical appeared to be in good condition with little or no TPS damage. Foam was missing or eroded from the horizontal (clamshell) section of the cable tray and the aft surface of the -Y vertical strut. Pieces of charred foam impacted the LH SRB aft booster and broke into smaller pieces.

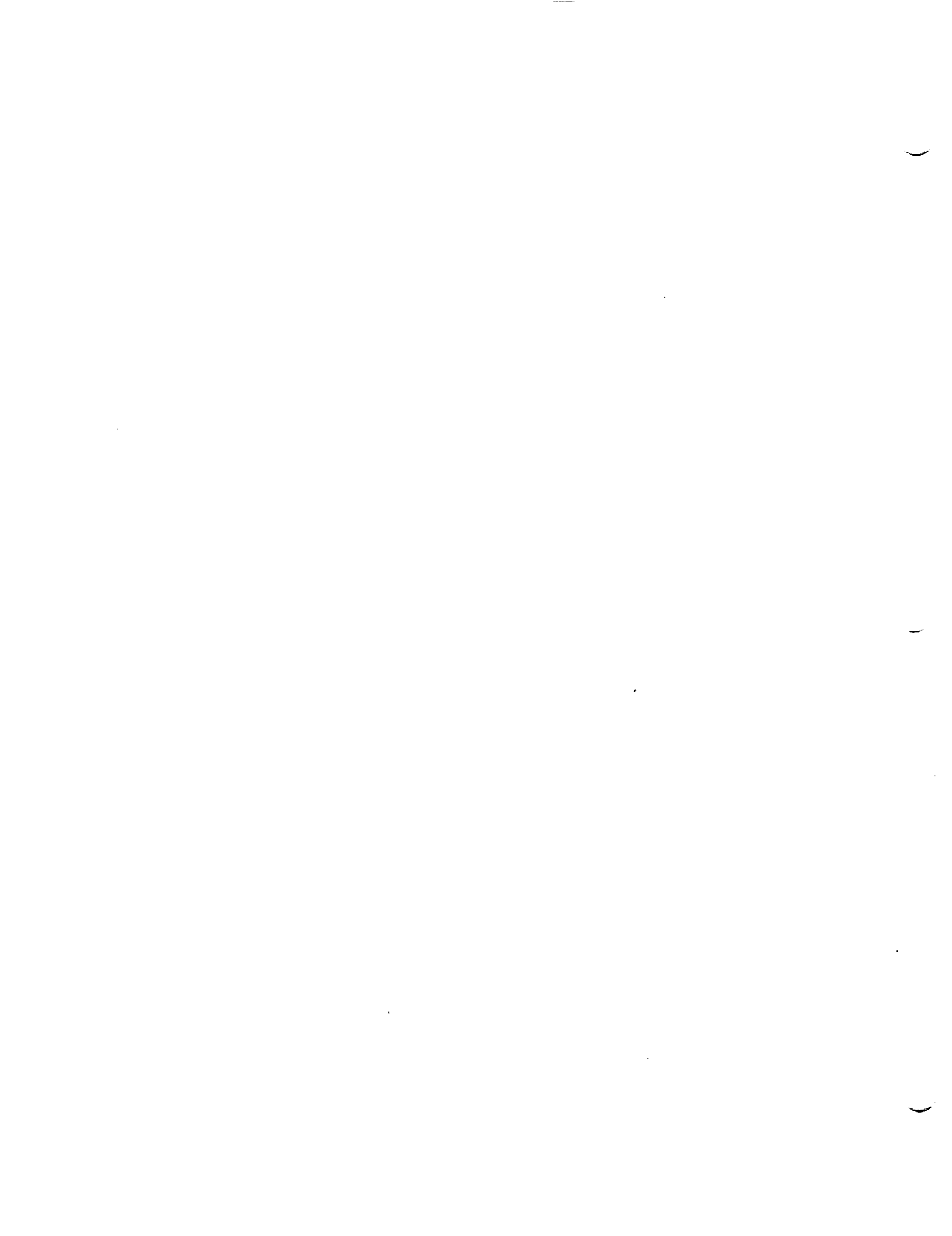



Photo 12: SRB Separation from External Tank

SRB separation from the External Tank was nominal. Foam was missing or eroded from the horizontal (clamshell) section of the cable tray and the aft surface of the -Y vertical strut. Pieces of charred foam impacted the LH SRB aft booster and broke into smaller pieces



5.3 LANDING FILM AND VIDEO SUMMARY

A total of 19 films and videos, which included seven 35mm large format films and twelve videos, were reviewed. The reduced landing coverage was caused by dark conditions for a night landing.

Wing tip vortices on final approach were visible in the Xenon lights due to the amount of moisture in the air at the time of landing.

The landing gear extended properly. The infrared scanners showed no debris falling from the Orbiter during final approach. Left and right main landing gear touchdown was almost simultaneous with the left side touching down first. The left MLG tire contacted the runway west of the centerline. The Orbiter rolled back to centerline after the drag chute was deployed.

Drag chute deployment appeared nominal.

Touchdown of the nose landing gear was smooth.

No significant TPS damage was visible. Rollout and wheel stop were uneventful.

6.0 SRB POST FLIGHT/RETRIEVAL DEBRIS ASSESSMENT

The BI-077 Solid Rocket Boosters were inspected for debris damage and debris sources at CCAS Hangar AF on 15 January 1996. From a debris standpoint, both SRB's were in excellent condition.

6.1 RH SOLID ROCKET BOOSTER DEBRIS INSPECTION

The RH frustum was missing no TPS. The number of debonds over fasteners (27) and over acreage (1) was close to the average (Figure 4). Hypalon paint was blistered/missing along the XB-395 ring frame where BTA closeouts had been applied. However, most of the exposed BTA substrate was not sooted. The BSM aero heat shield covers had locked in the fully opened position though the two lower cover attach rings had been bent slightly by parachute riser entanglement.

The RH forward skirt exhibited no debonds or missing TPS. Both RSS antennae covers/phenolic base plates were intact though phenolic layers in the +Z plate were delaminated. Hypalon paint was blistered/missing over the areas where BTA closeouts had been applied. No pins or retainer clips from the frustum severance ring were missing or damaged.

The Field Joint Protection System (FJPS) closeouts were generally in good condition. Trailing edge damage to the FJPS and the GEI cork runs were attributed to debris resulting from severance of the nozzle extension.

Separation of the aft ET/SRB struts appeared normal. K5NA 3-inches long by 1-inch wide was missing from the separation plane of the upper strut fairing. The ETA ring, IEA, and IEA covers appeared undamaged. The aft booster stiffener ring splice plate closeouts were intact and no K5NA material was missing.

Aft skirt MSA-2 was intact. The HDP Debris Containment System (DCS) plungers appeared to have functioned properly. However, a 0.5-inch by 0.25-inch piece of ordnance debris was wedged against the HDP #4 plunger and prevented full seating.

**STS-72
RIGHT SRB FRUSTUM**

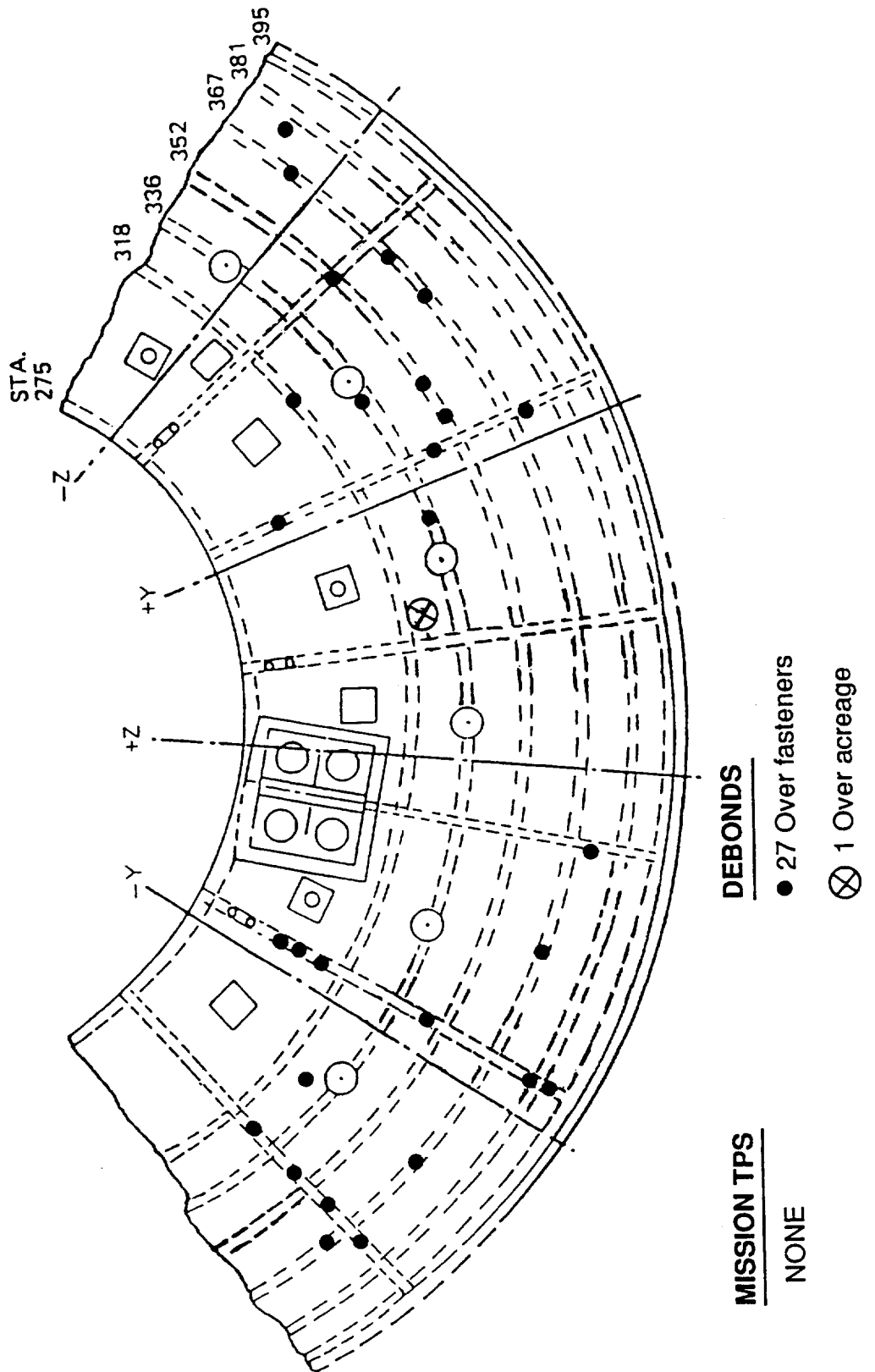
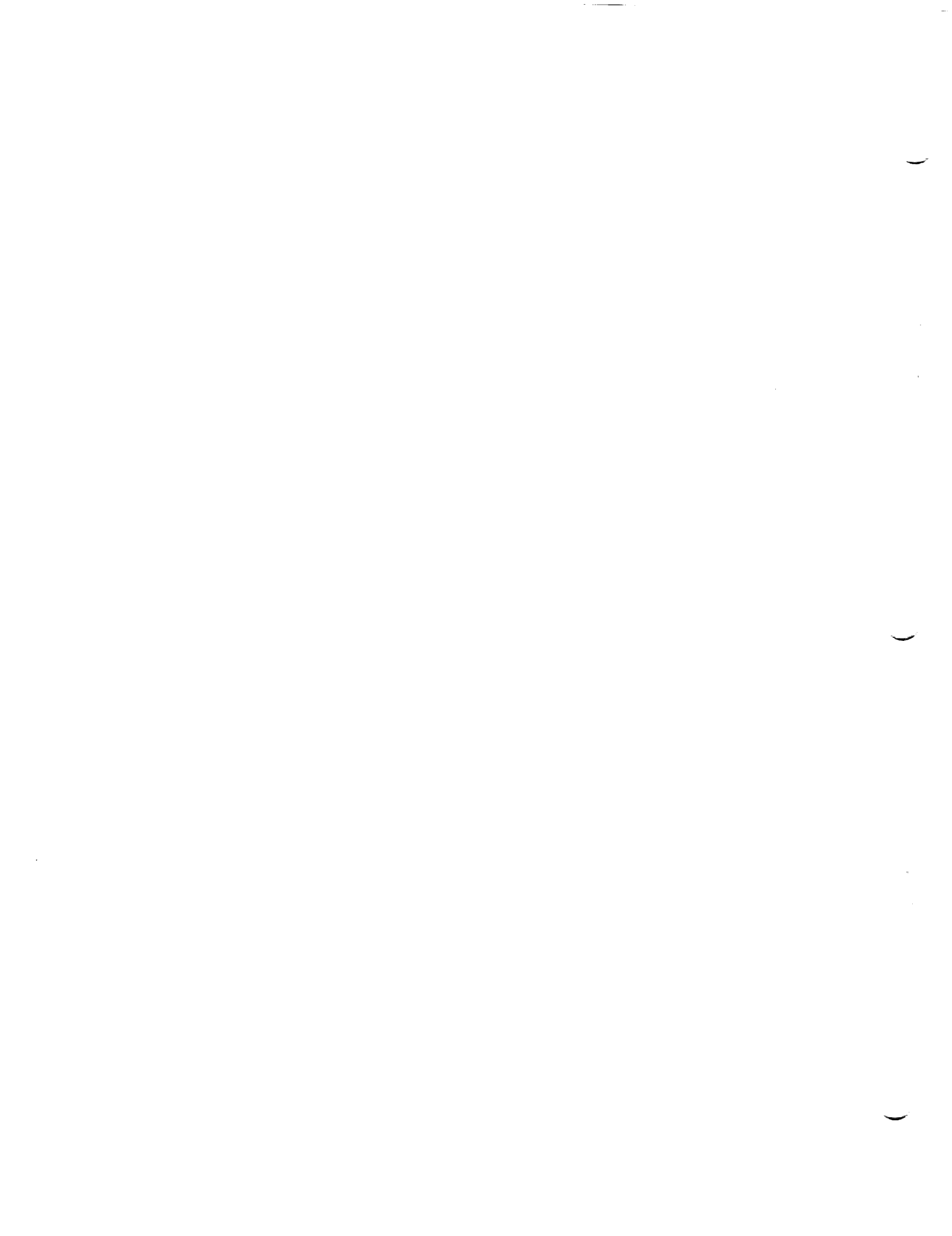

Figure 4: RH SRB Frustum



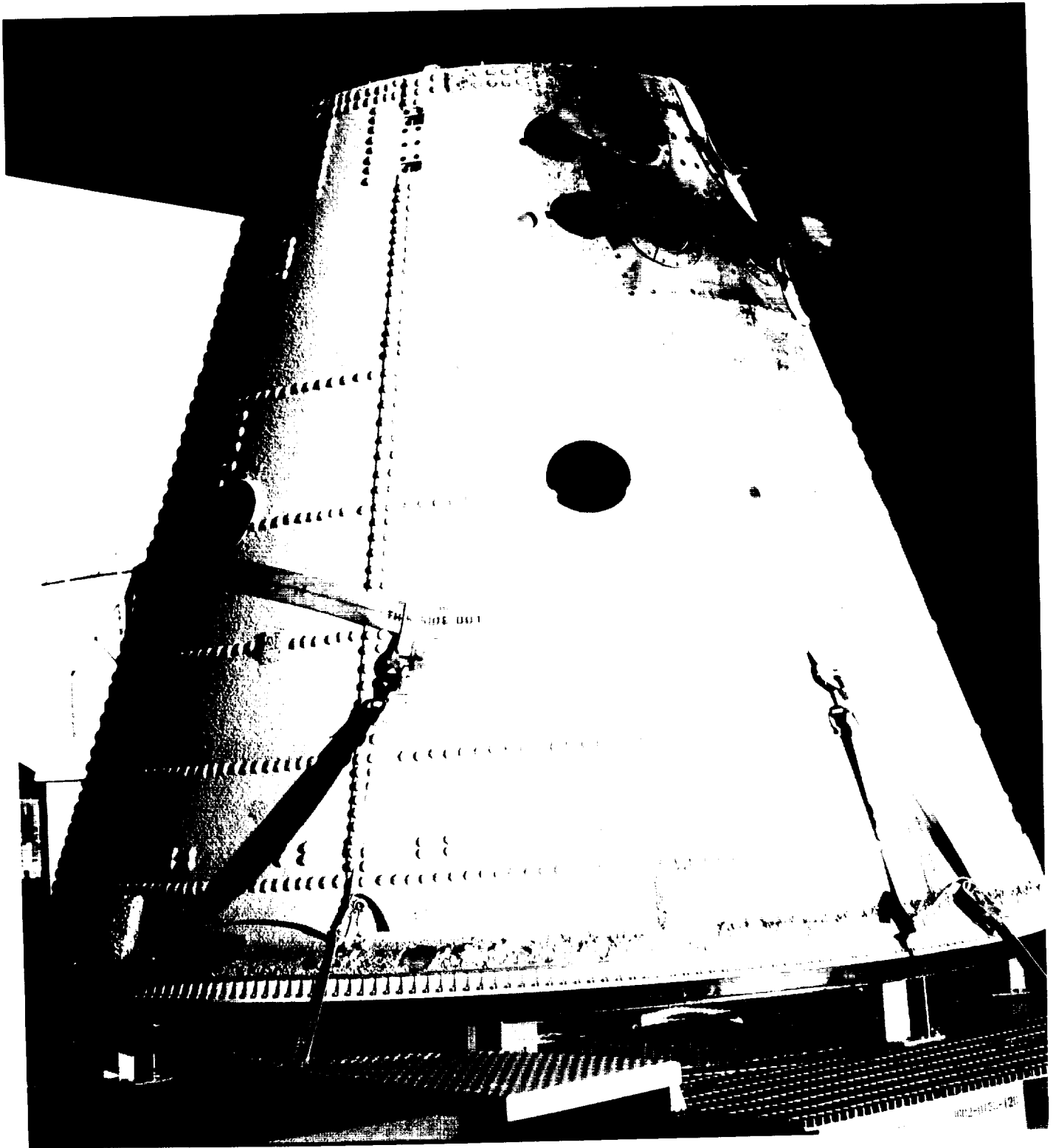
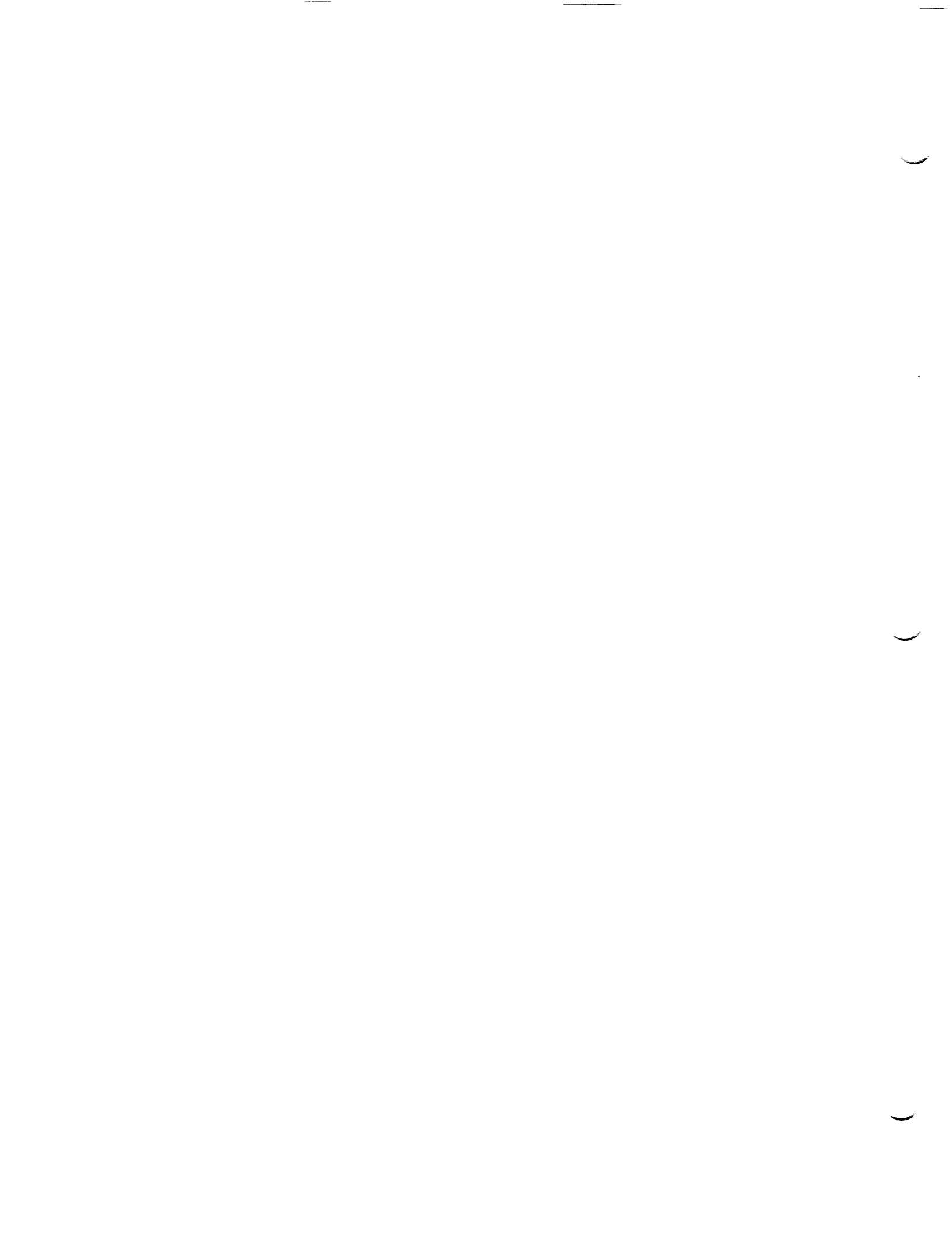

Photo 13: RH Frustum

The RH frustum was missing no TPS. The number of debonds over fasteners (27) and over acreage (1) was close to the average. Hypalon paint was blistered/missing along the XB-395 ring frame where BTA closeouts had been applied. However, most of the exposed BTA substrate was not sooted. The BSM aero heat shield covers had locked in the fully opened position though the two lower cover attach rings had been bent slightly by parachute riser entanglement.



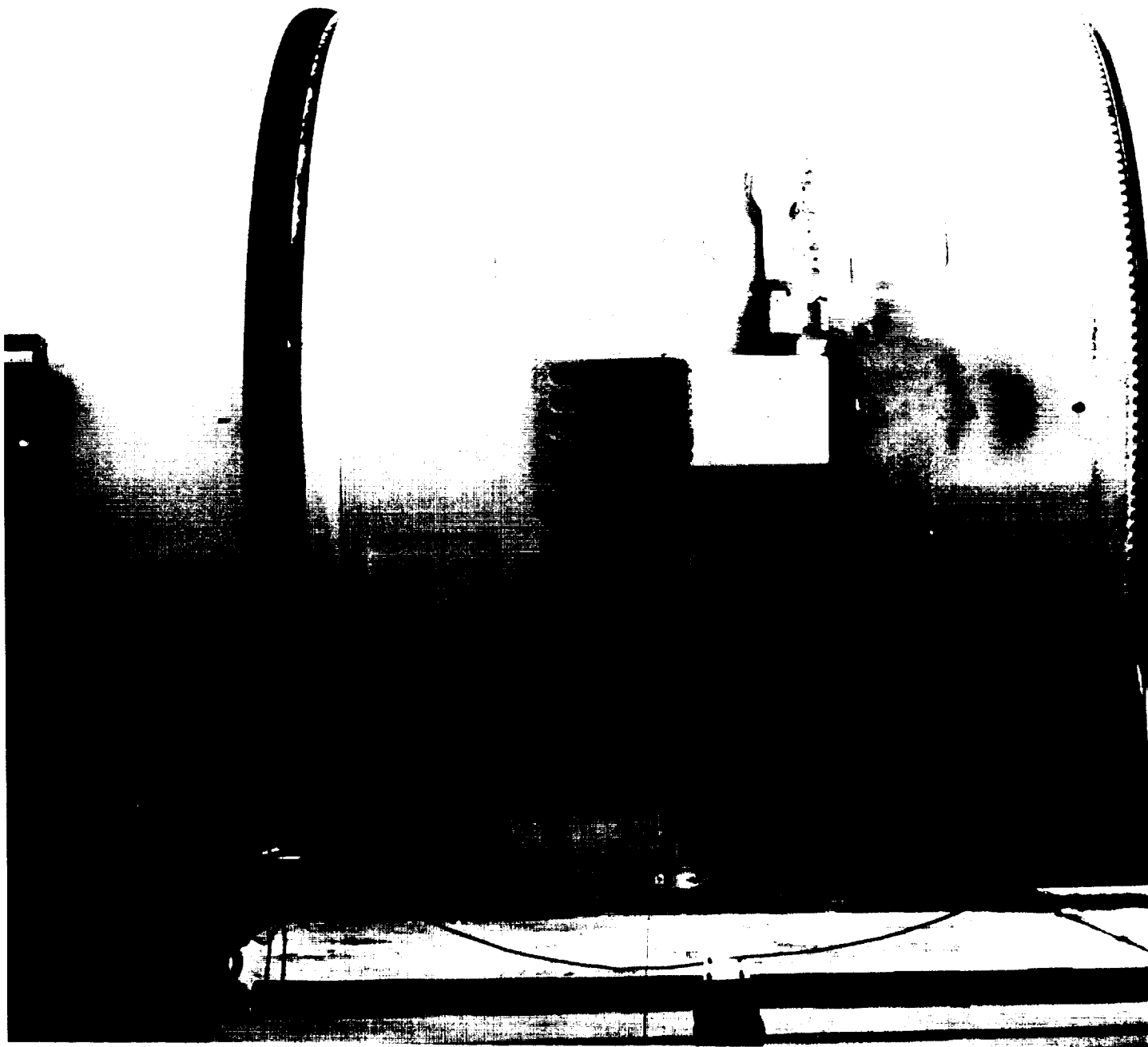

Photo 14: RH Forward Skirt

The RH forward skirt exhibited no debonds or missing TPS. Both RSS antennae covers/phenolic base plates were intact though phenolic layers in the +Z plate were delaminated. Hypalon paint was blistered/missing over the areas where BTA closeouts had been applied. No pins or retainer clips from the frustrum severance ring were missing or damaged.

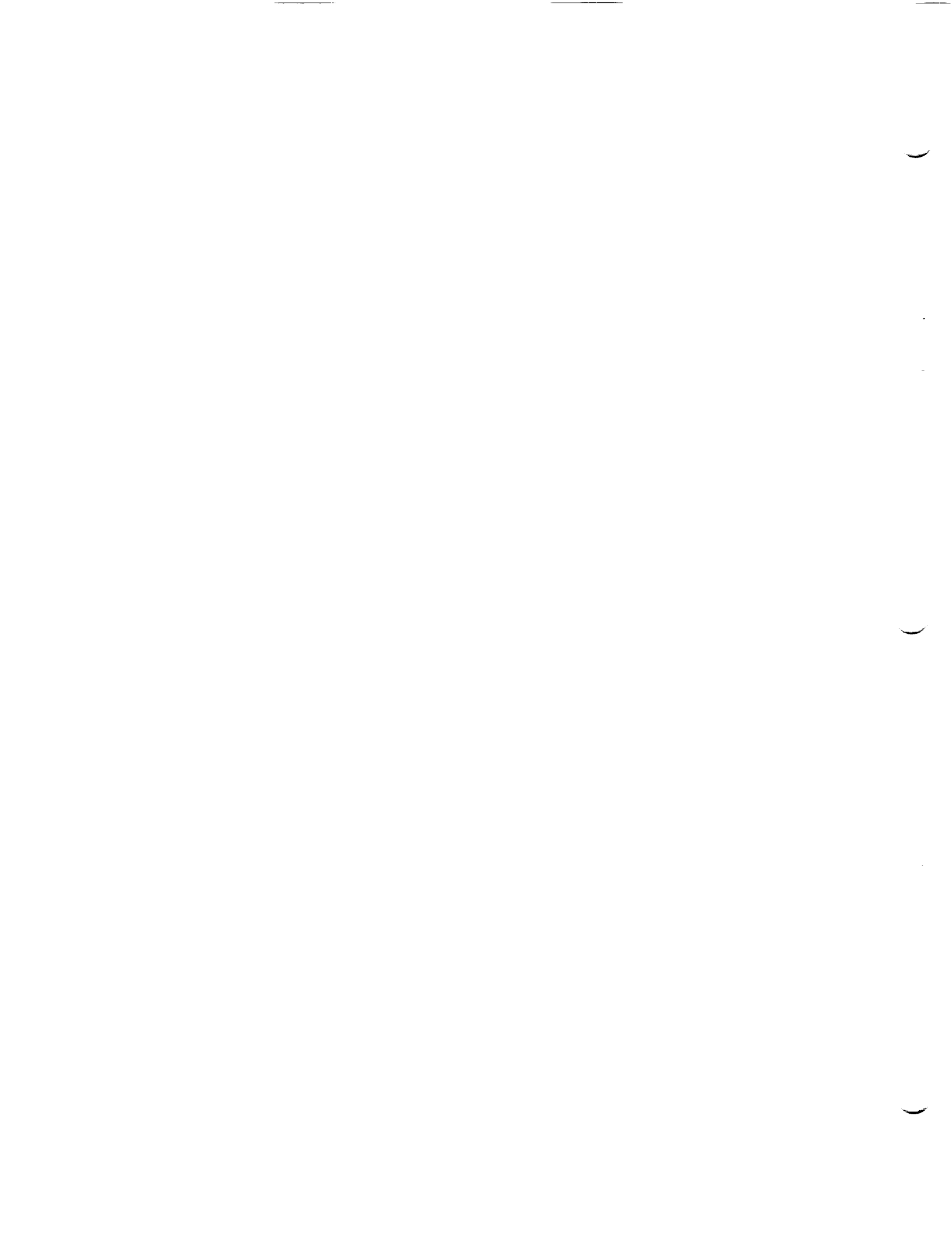



Photo 15: Upper Strut Fairing Missing K5NA

Separation of the aft ET/SRB struts appeared normal. K5NA 3-inches long by 1-inch wide was missing from the separation plane of the upper strut fairing.

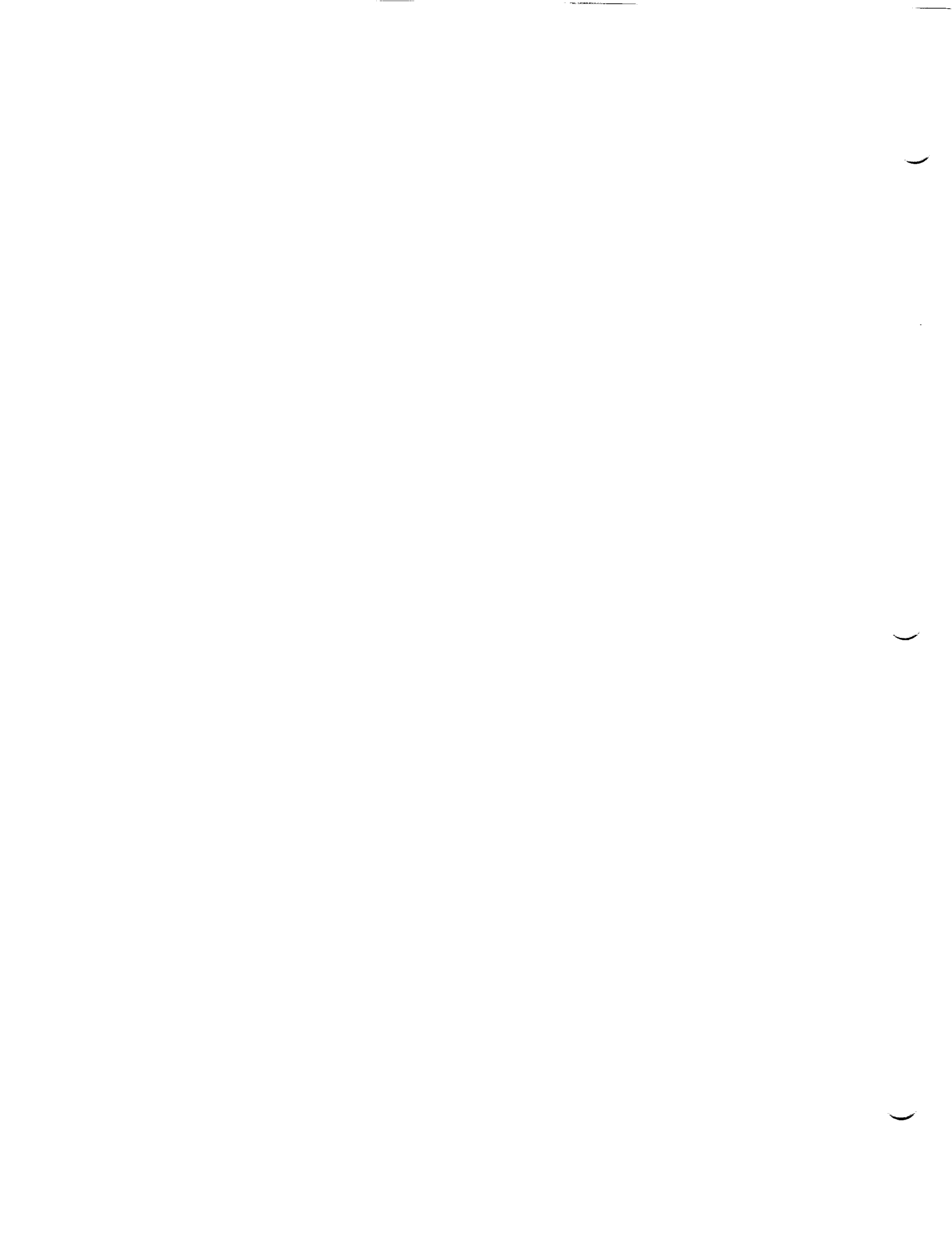
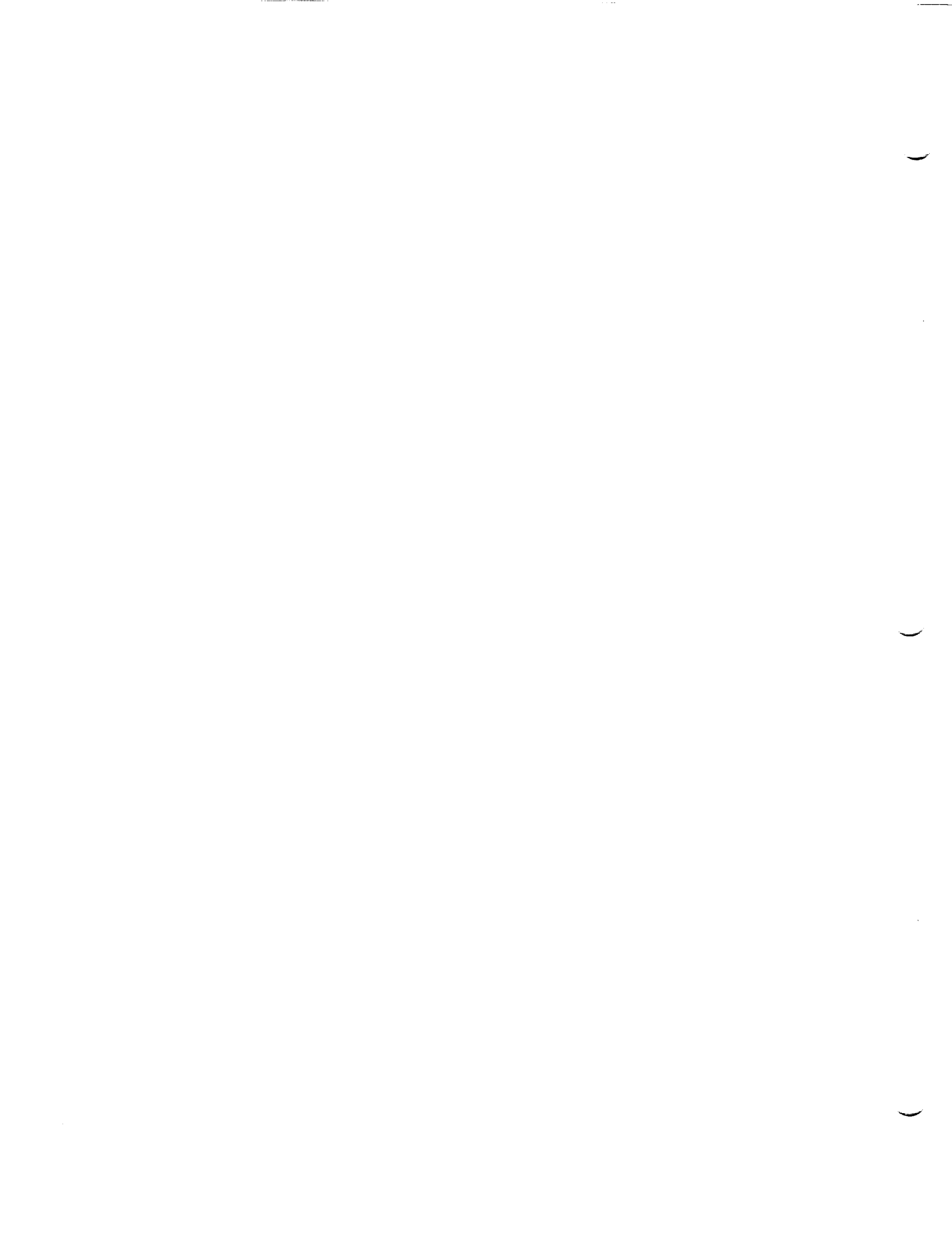



Photo 16: RH Aft Booster/ Aft Skirt



6.2 LH SOLID ROCKET BOOSTER DEBRIS INSPECTION

The LH frustum was missing no TPS. The number of MSA-2 debonds over fasteners (36) was average (Figure 5). Hypalon paint was blistered/missing along the XB-395 ring frame where BTA closeouts had been applied. However, most of the exposed BTA substrate was not sooted. The BSM aero heat shield covers had locked in the fully opened position.

The LH forward skirt exhibited no TPS debonds. One 1-inch diameter MSA-2 divot was located near the EB fitting. Both RSS antennae covers/phenolic base plates were intact. Hypalon paint was blistered/missing over the areas where BTA closeouts had been applied. No pins or retainer clips from the frustum severance ring were missing or damaged.

The Field Joint Protection System (FJPS) closeouts were generally in good condition. Trailing edge damage to the FJPS and the GEI cork runs were attributed to debris resulting from severance of the nozzle extension.

Separation of the aft ET/SRB struts appeared normal. K5NA 3.5-inches long by 1-inch wide was missing from the separation plane of the upper strut fairing. The ETA ring, IEA, and IEA covers appeared undamaged. The stiffener ring splice plate closeouts were intact and no K5NA material was missing.

Aft skirt MSA-2 was intact. The HDP Debris Containment System (DCS) plungers were seated and appeared to have functioned properly.

SRB Post Launch Anomalies are listed in Section 9.

**STS-72
LEFT SRB FRUSTUM**

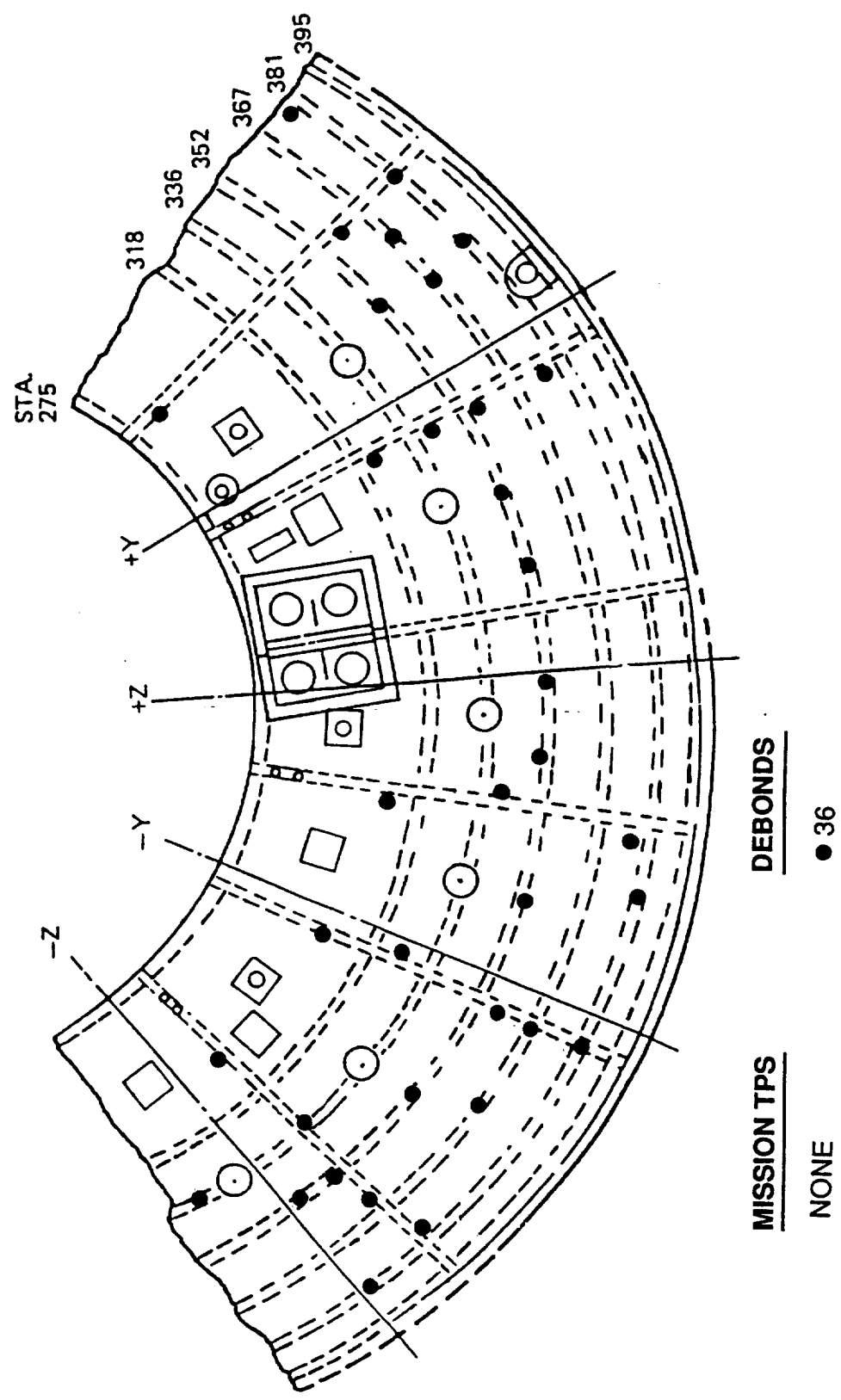

Figure 5: LH SRB Frustum

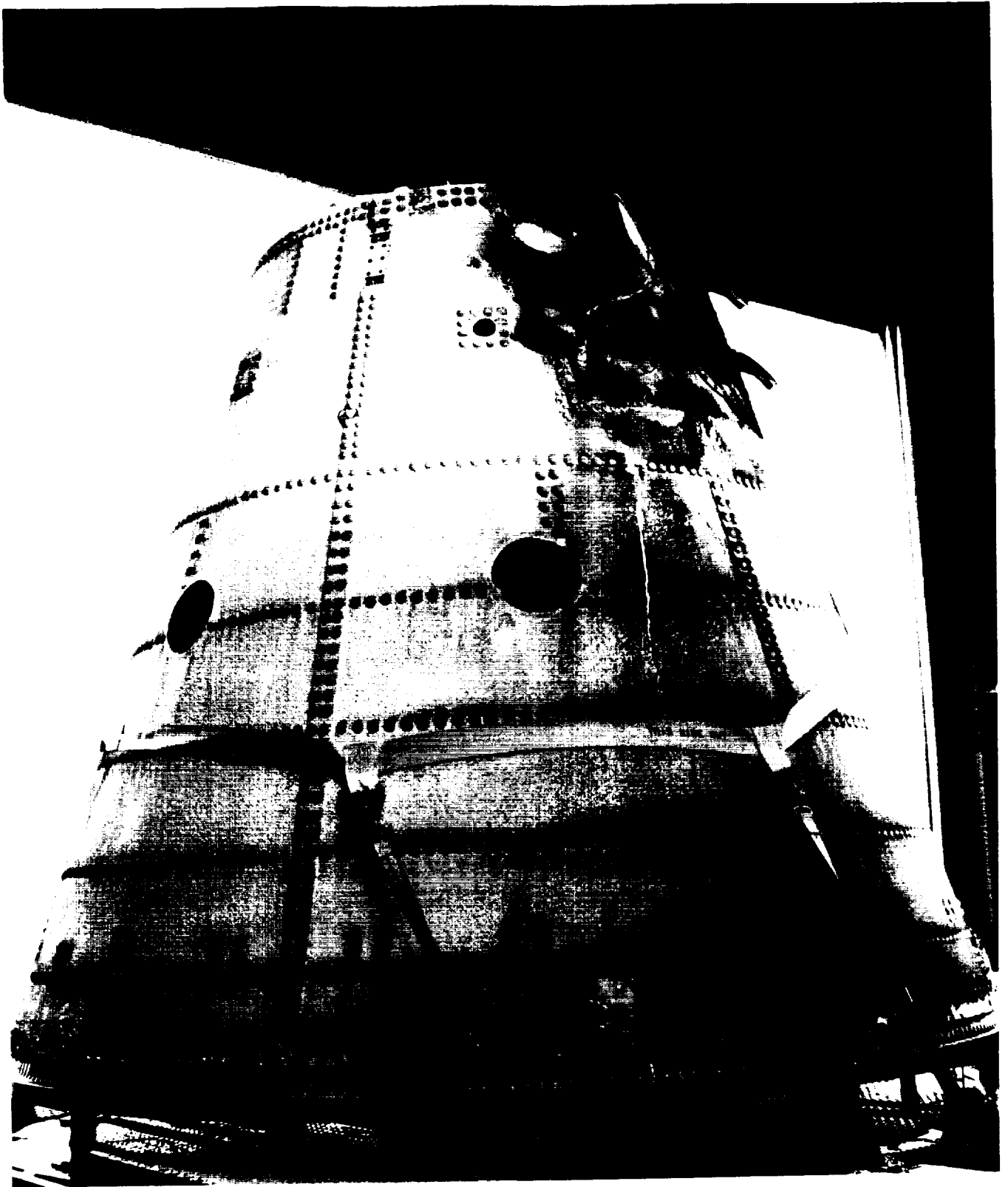
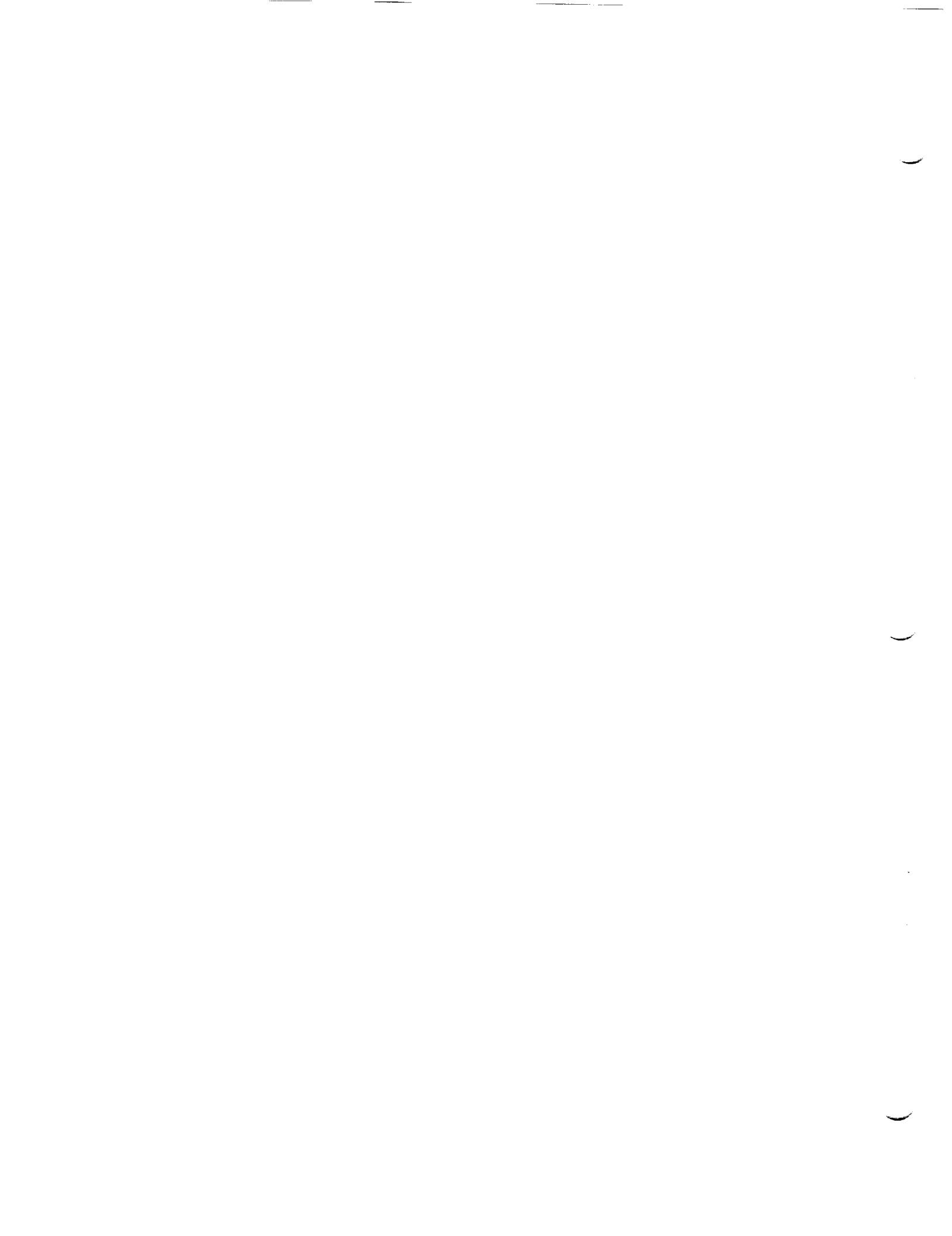

Photo 17: LH Frustum

The LH frustum was missing no TPS. The number of MSA-2 debonds over fasteners (36) was average. Hypalon paint was blistered/missing along the XB-395 ring frame where BTA closeouts had been applied. However, most of the exposed BTA substrate was not sooted. The BSM aero heat shield covers had locked in the fully opened position.



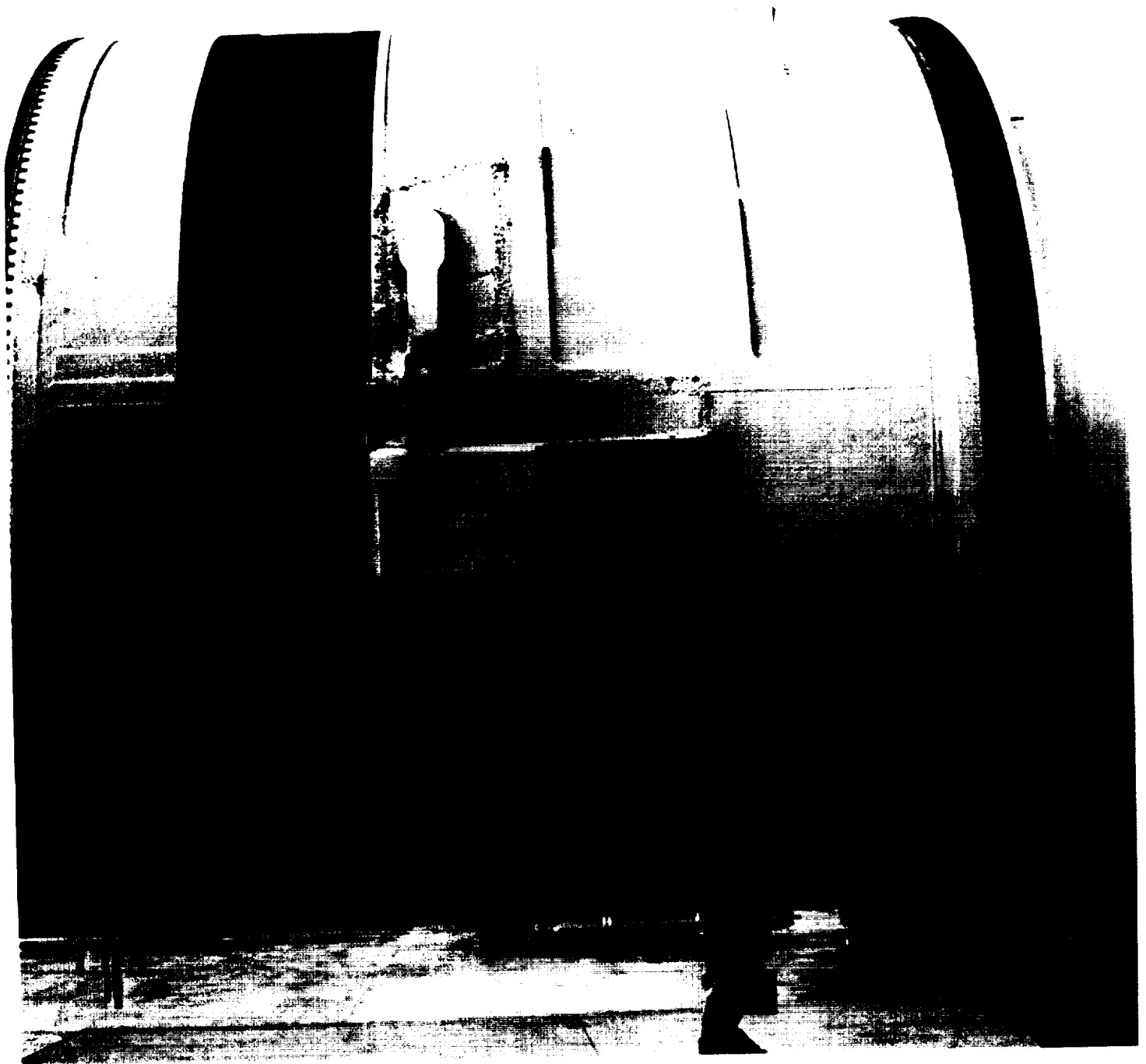
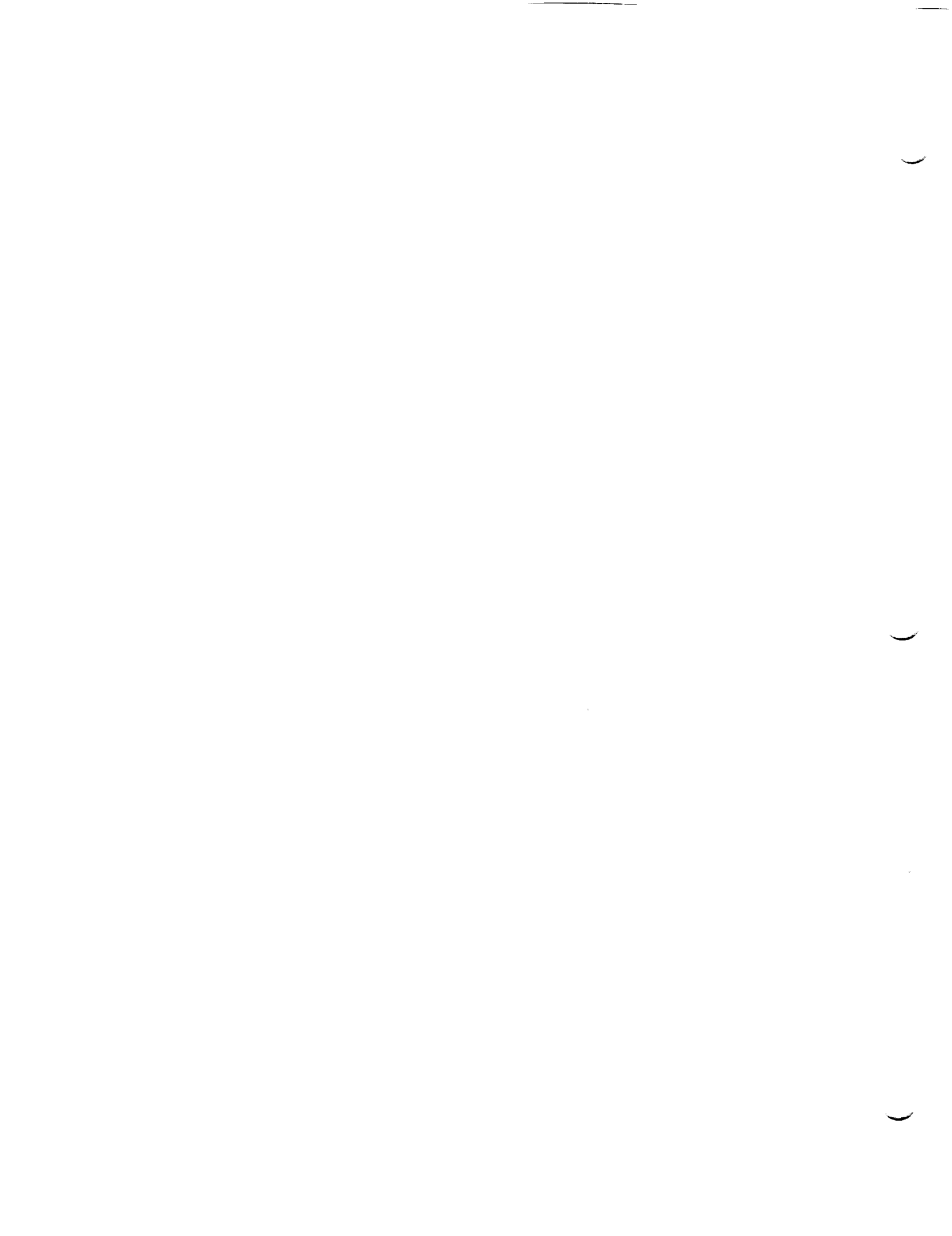

Photo 18: LH Forward Skirt

The LH forward skirt exhibited no TPS debonds. One 1-inch diameter MSA-2 divot was located near the EB fitting. Both RSS antennae covers/phenolic base plates were intact. Hypalon paint was blistered/missing over the areas where BTA closeouts had been applied. No pins or retainer clips from the frustrum severance ring were missing or damaged.



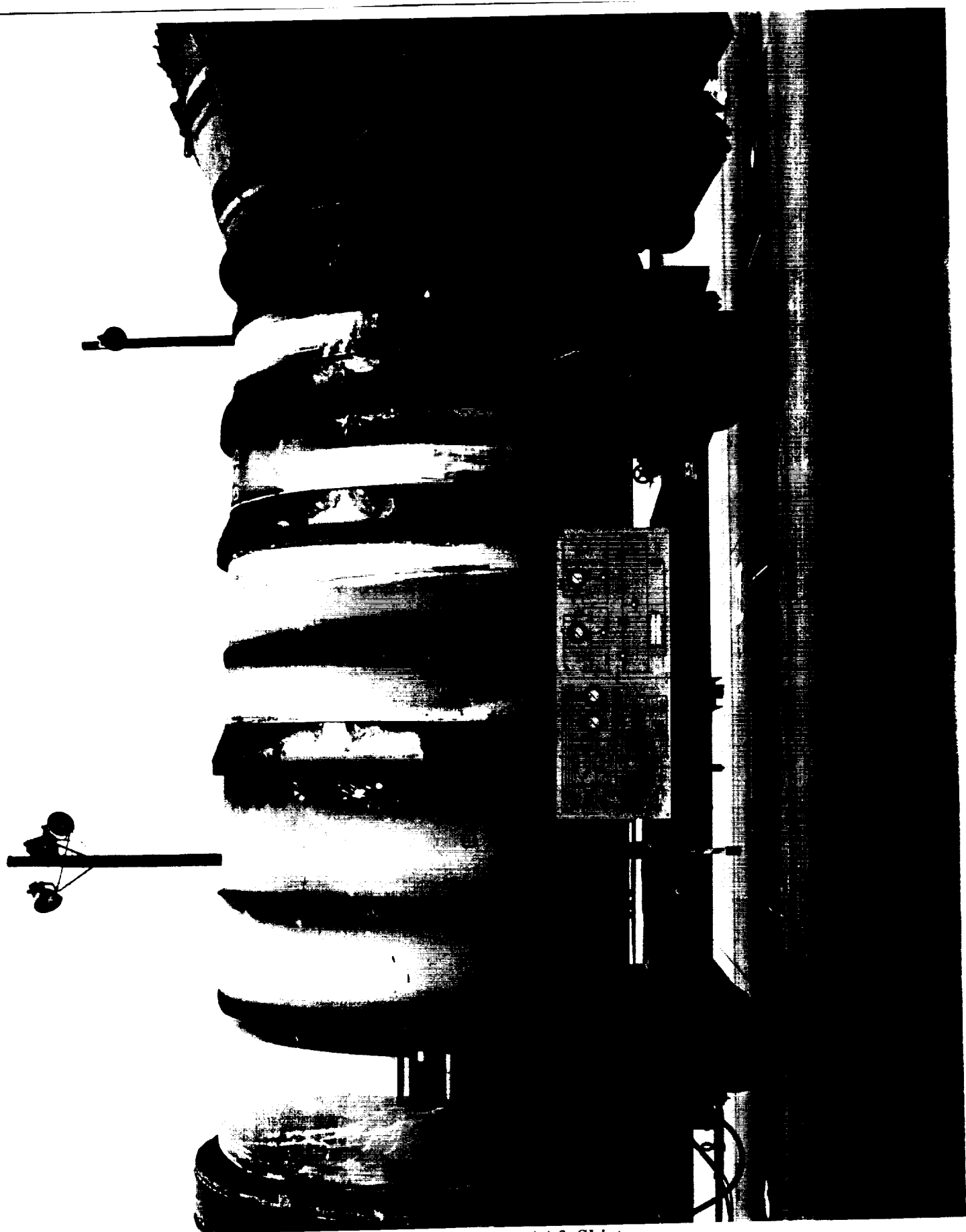
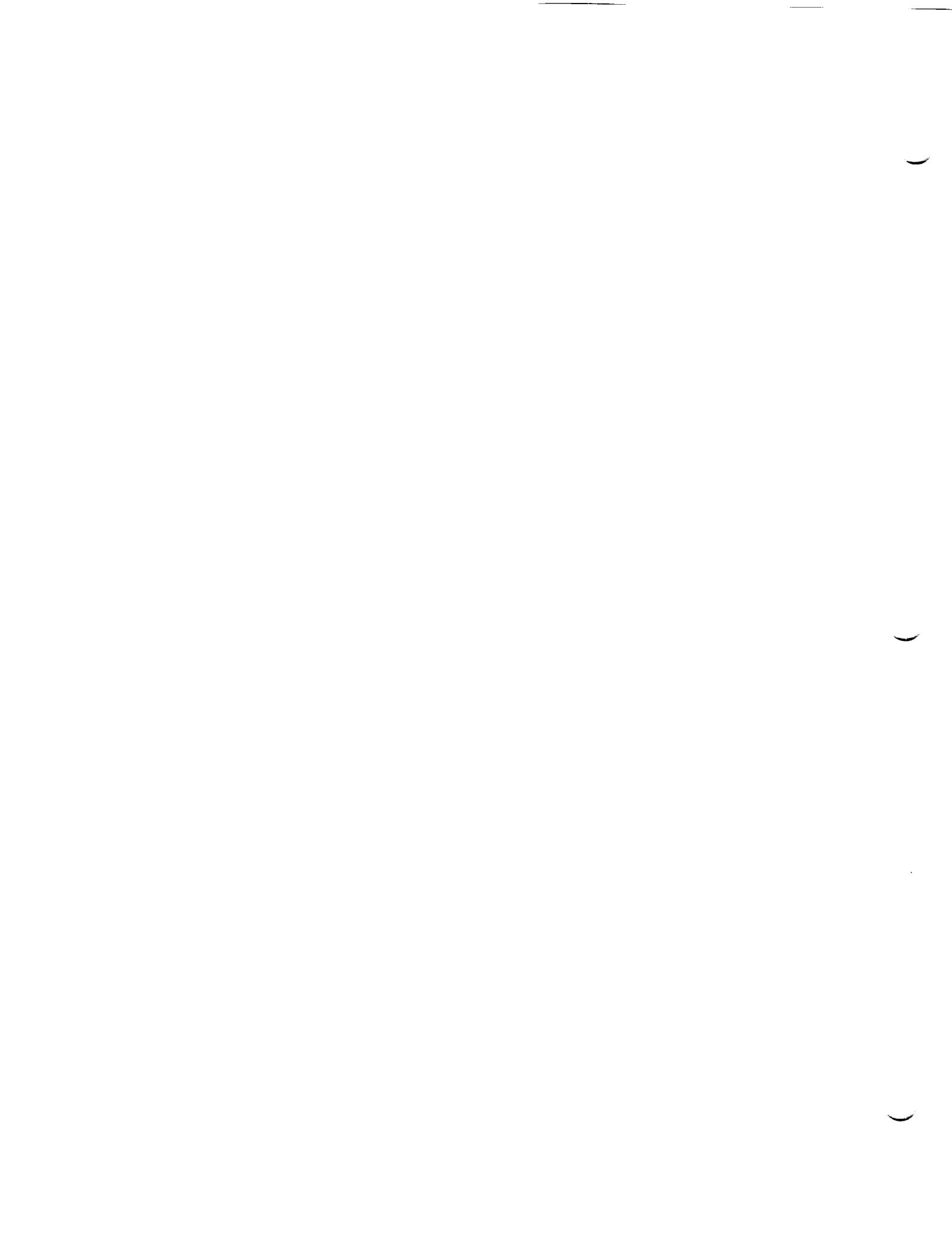

Photo 19: LH Aft Booster/ Aft Skirt

Aft skirt MSA-2 was intact. The HDP Debris Containment System (DCS) plungers were seated and appeared to have functioned properly.



7.0 ORBITER POST LANDING DEBRIS ASSESSMENT

A post landing debris inspection of OV-105 Endeavour was conducted 20-21 January 1996 at the Kennedy Space Center on SLF runway 15 and in the Orbiter Processing Facility bay #3. This inspection was performed to identify debris impact damage and, if possible, debris sources. The Orbiter TPS sustained a total of 55 hits, of which 6 had a major dimension of 1-inch or larger. This total does not include the numerous hits on the base heat shield attributed to SSME vibration/acoustics and exhaust plume recirculation. A comparison of these numbers to statistics from 57 previous missions of similar configuration (excluding missions STS-23, 25, 26, 26R, 27R, 30R, and 42, which had damage from known debris sources), indicates both the total number of hits and the number of hits 1-inch or larger was exceptionally less than average (reference Figures 6-9).

The following table breaks down the STS-72 Orbiter debris damage by area:

	<u>HITS > 1"</u>	<u>TOTAL HITS</u>
Lower surface	3	23
Upper surface	1	22
Right side	0	1
Left side	0	2
Right OMS Pod	0	4
Left OMS Pod	2	3
TOTALS	6	55

Virtually no tile damage sites were recorded aft of the ET/ORB LH2 and LO2 umbilicals. Damage sites in this area are typically caused by impacts from umbilical ice or shredded pieces of umbilical purge barrier material flapping in the airstream. A possible reason for this unusual finding was the absence of ice on the umbilicals after being shaken loose during SSME ignition prior to liftoff.

No tile damage from micrometeorites or on-orbit debris was identified during the inspection.

The tires and brakes were reported to be in good condition for a landing on the KSC concrete runway.

ET/Orbiter separation devices EO-1, EO-2, and EO-3 functioned normally. All ET/Orbiter umbilical separation ordnance retention shutters were closed properly. Three clips were missing from both EO-2 and EO-3 fitting "salad bowls". Virtually no umbilical closeout foam or white RTV dam material adhered to the umbilical plate near the LH2 recirculation line disconnect. The only debris found on the runway under the umbilical cavities (LH2) consisted of a bolt 0.875-inches long by 0.1875-inch diameter with a red coating on the bolt head. The bolt, which is stamped with the number MS 21279-7, is used in the Orbiter aft compartment SSME wire bundle clamps. A post flight inspection of the aft revealed no missing bolts (Ref. Lost and Found PR LAF-5-11-0199).

All three Dome Mounted Heat Shield (DMHS) closeout blankets were in excellent condition with no missing material. Tiles on the vertical stabilizer "stinger" and around the drag chute door were intact and undamaged.

No ice adhered to the payload bay door. A white residue was observed around the waste water dump nozzles. Some, but no unusual, tile damage sites were documented on the leading edges of the OMS pods and vertical stabilizer.

Less than usual hazing was visible on the Orbiter windows. Eighteen damage sites on the window perimeter tiles was most likely caused by impacts from FRCS thruster paper covers and RTV adhesive.

The post landing walkdown of Runway 15 was performed immediately after landing. The only flight hardware debris found on the runway was located in the general vicinity of the pilot chute at the 4800 foot marker. The debris consisted of a 1.25-inch long by 0.75-inch wide piece of black-coated metallic speed brake spring clip from the hinge area of the rudder near the split. All drag chute hardware was recovered at the expected places on the runway. The drag chute appeared to have functioned normally and no significant damage was observed on any of the chute components.

In summary, both the total number of Orbiter TPS debris hits and the number of hits 1-inch or larger was significantly less than average when compared to previous missions.

Orbiter Post Launch Debris Anomalies are listed in Section 9.

DEBRIS DAMAGE LOCATIONS

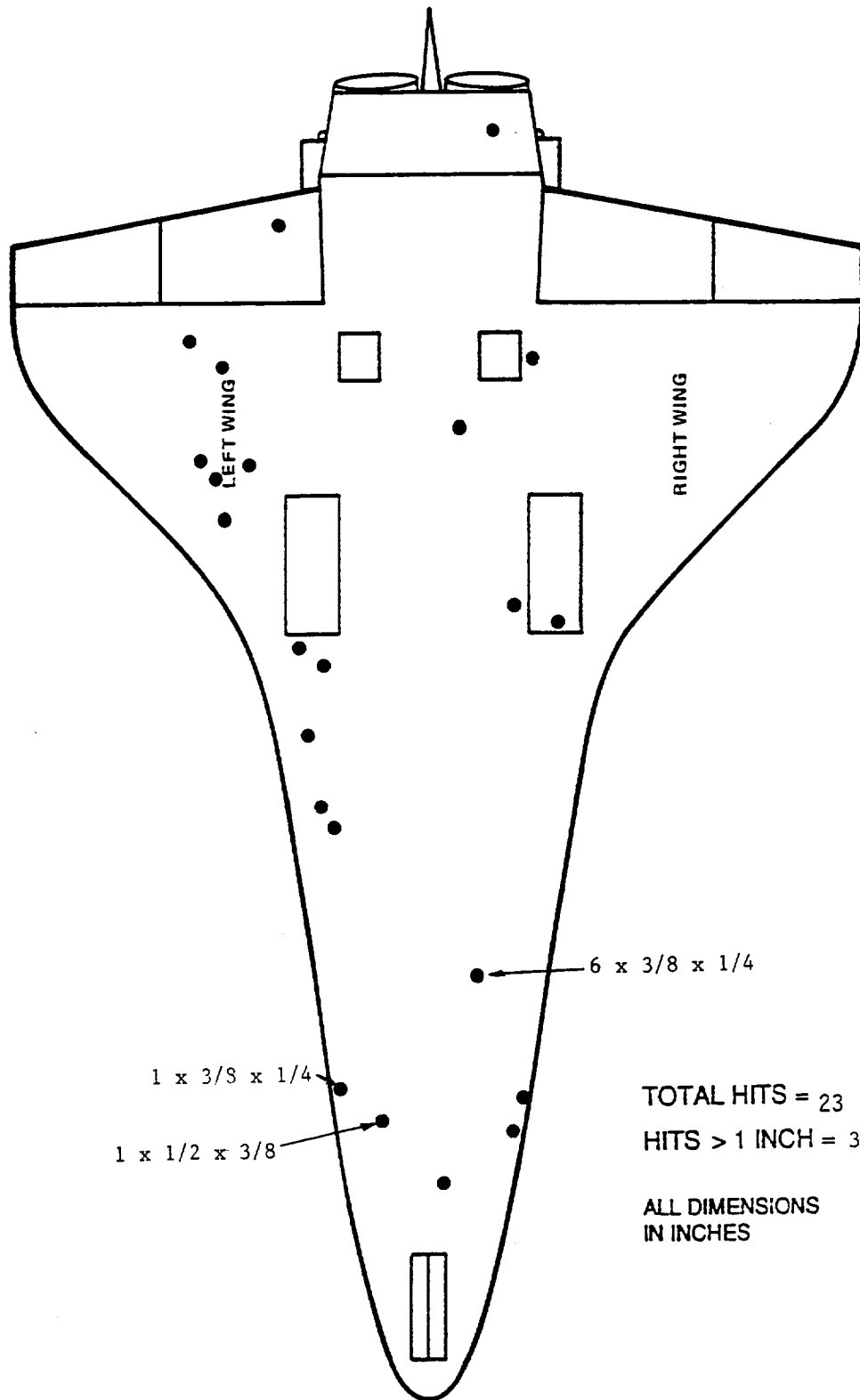

Figure 6: Orbiter Lower Surface Debris Map

STS-72

DEBRIS DAMAGE LOCATIONS

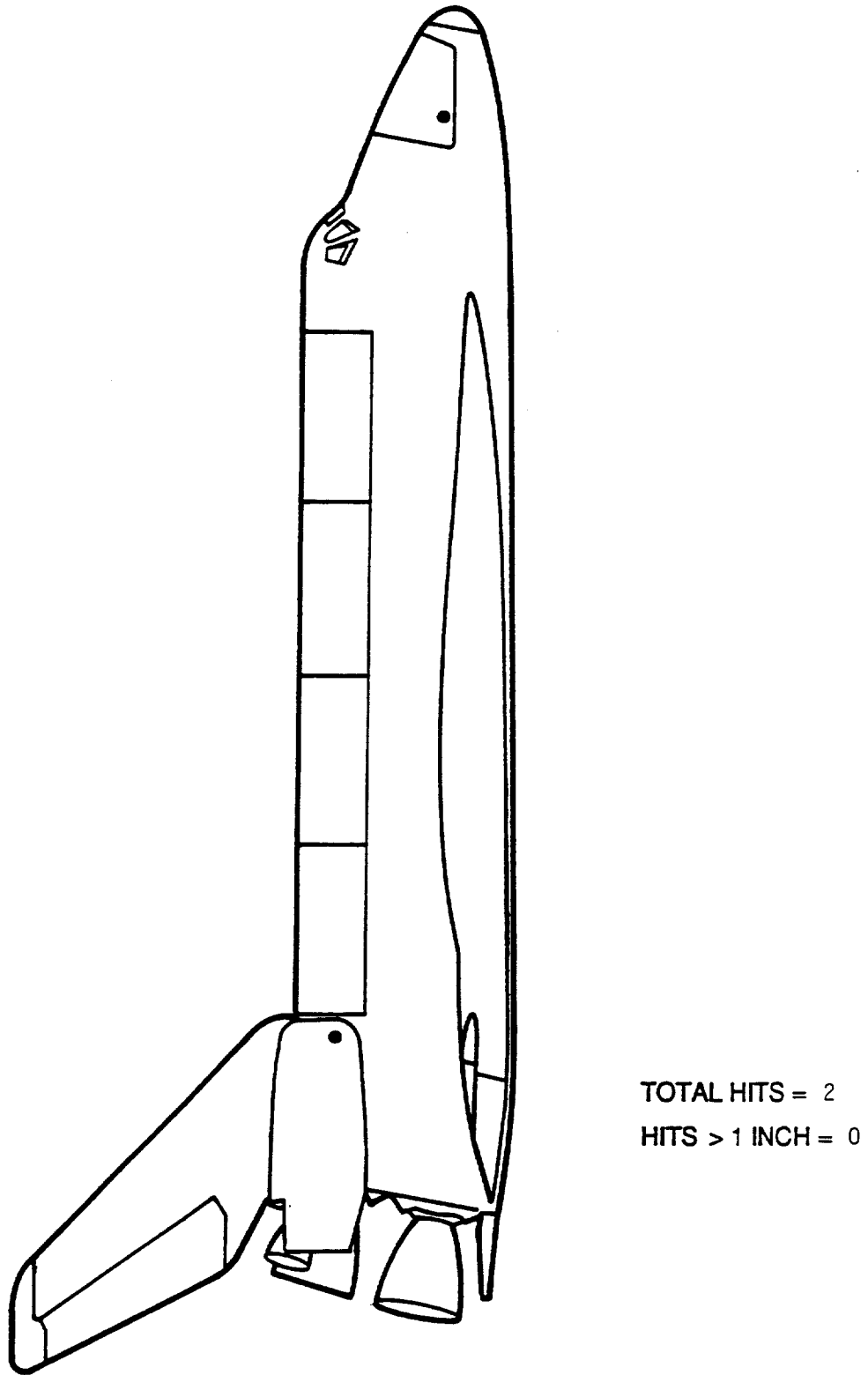
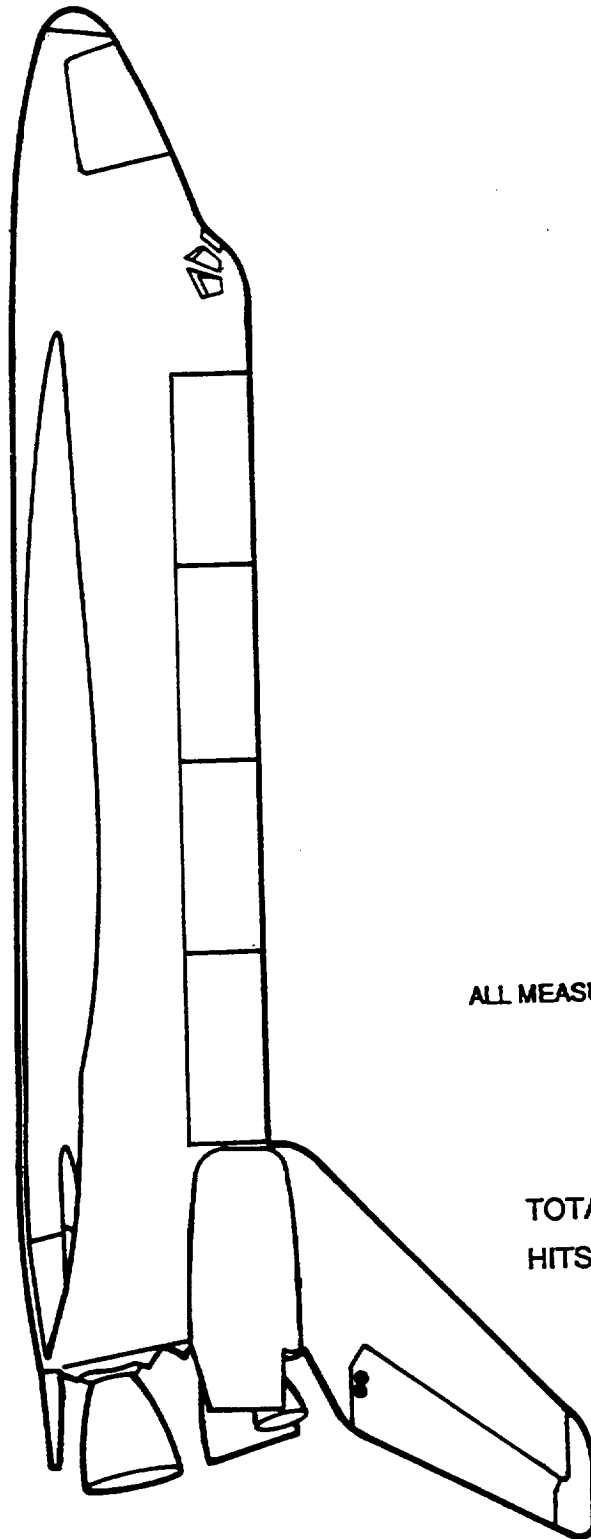

Figure 7: Orbiter Right Side Debris Map

STS-72

DEBRIS DAMAGE LOCATIONS



ALL MEASUREMENTS IN INCHES

TOTAL HITS = 2

HITS > 1 INCH = 0

Figure 8: Orbiter Left Side Debris Map

STS-72
DEBRIS DAMAGE LOCATIONS

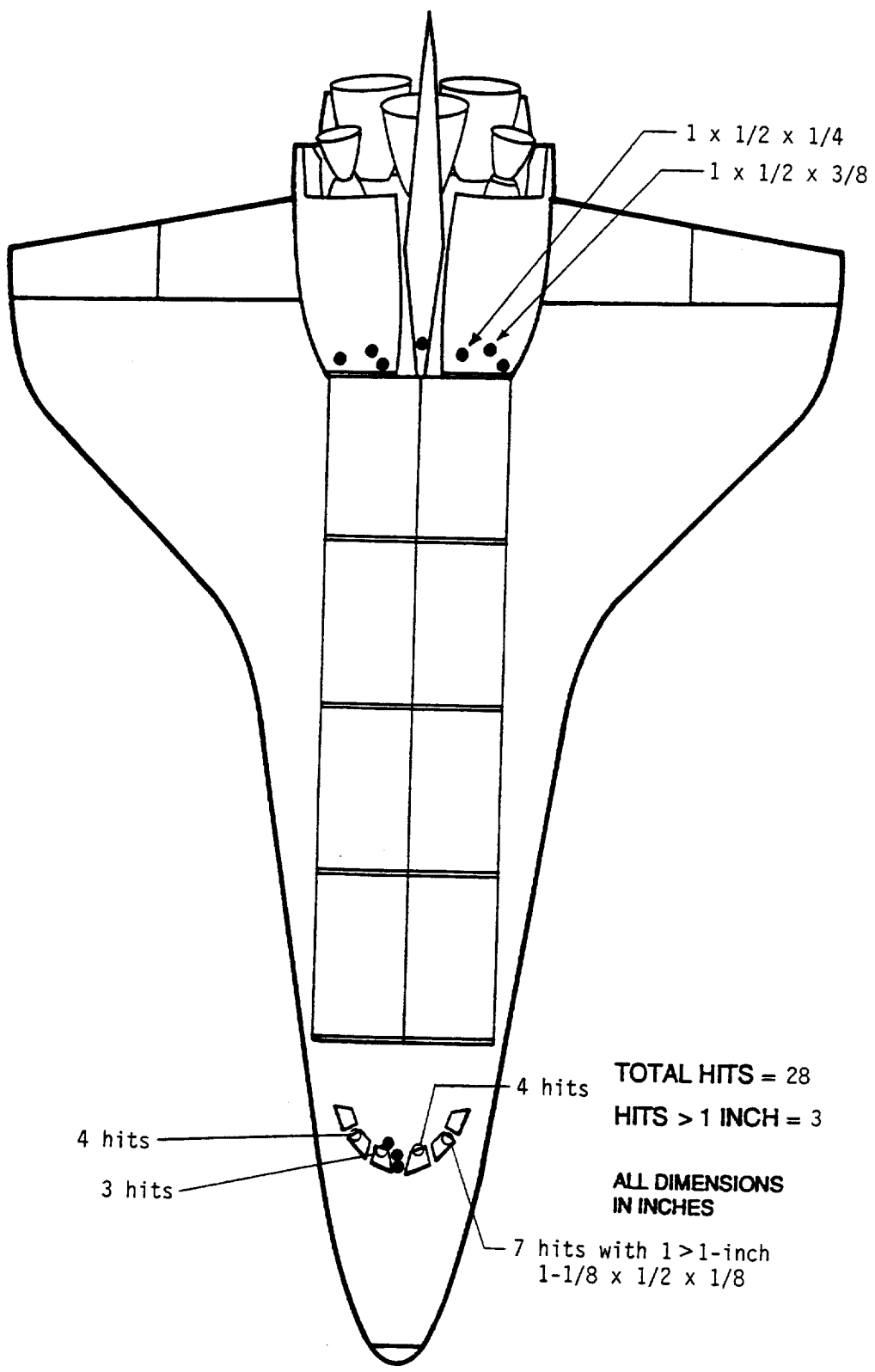

Figure 9: Orbiter Upper Surface Debris Map

ORBITER POST FLIGHT DEBRIS DAMAGE SUMMARY

	LOWER SURFACE		ENTIRE VEHICLE	
	HITS > 1 INCH	TOTAL HITS	HITS > 1 INCH	TOTAL HITS
STS-6	15	80	36	120
STS-8	3	29	7	56
STS-9 (41-A)	9	49	14	58
STS-11 (41-B)	11	19	34	63
STS-13 (41-C)	5	27	8	36
STS-14 (41-D)	10	44	30	111
STS-17 (41-G)	25	69	36	154
STS-19 (51-A)	14	66	20	87
STS-20 (51-C)	24	67	28	81
STS-27 (51-I)	21	96	33	141
STS-28 (51-J)	7	66	17	111
STS-30 (61-A)	24	129	34	183
STS-31 (61-B)	37	177	55	257
STS-32 (61-C)	20	134	39	193
STS-29	18	100	23	132
STS-28R	13	60	20	76
STS-34	17	51	18	53
STS-33R	21	107	21	118
STS-32R	13	111	15	120
STS-36	17	61	19	81
STS-31R	13	47	14	63
STS-41	13	64	16	76
STS-38	7	70	8	81
STS-35	15	132	17	147
STS-37	7	91	10	113
STS-39	14	217	16	238
STS-40	23	153	25	197
STS-43	24	122	25	131
STS-48	14	100	25	182
STS-44	6	74	9	101
STS-45	18	122	22	172
STS-49	6	55	11	114
STS-50	28	141	45	184
STS-46	11	186	22	236
STS-47	3	48	11	108
STS-52	6	152	16	290
STS-53	11	145	23	240
STS-54	14	80	14	131
STS-56	18	94	36	156
STS-55	10	128	13	143
STS-57	10	75	12	106
STS-51	8	100	18	154
STS-58	23	78	26	155
STS-61	7	59	13	120
STS-60	4	48	15	106
STS-62	7	36	16	97
STS-59	10	47	19	77
STS-65	17	123	21	151
STS-64	18	116	19	150
STS-68	9	59	15	110
STS-66	22	111	28	148
STS-63	7	84	14	125
STS-67	11	47	13	76
STS-71	24	149	25	164
STS-70	5	81	9	127
STS-69	22	175	27	198
STS-73	17	102	26	147
STS-74	17	78	21	116
AVERAGE	14.2	91.9	21.1	132.1
SIGMA	7.1	43.2	9.7	53.5
STS-72	3	23	6	55

MISSIONS STS-23, 24, 25, 26, 26R, 27R, 30R, AND 42 ARE NOT INCLUDED IN THIS ANALYSIS
SINCE THESE MISSIONS HAD SIGNIFICANT DAMAGE CAUSED BY KNOWN DEBRIS SOURCES

Figure 10: Orbiter Post Flight Debris Damage Summary

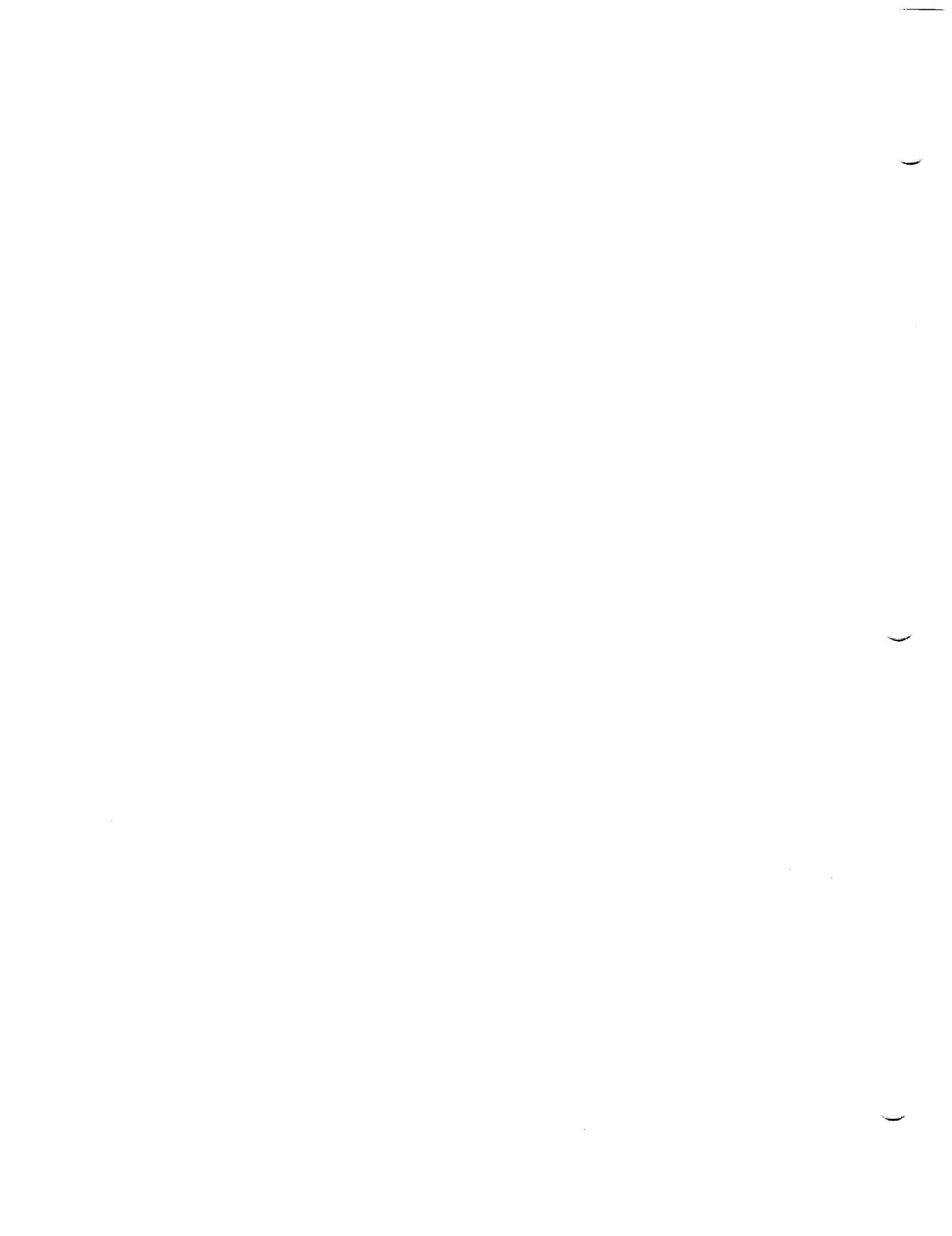



Photo 20: Overall View of Orbiter Left Side

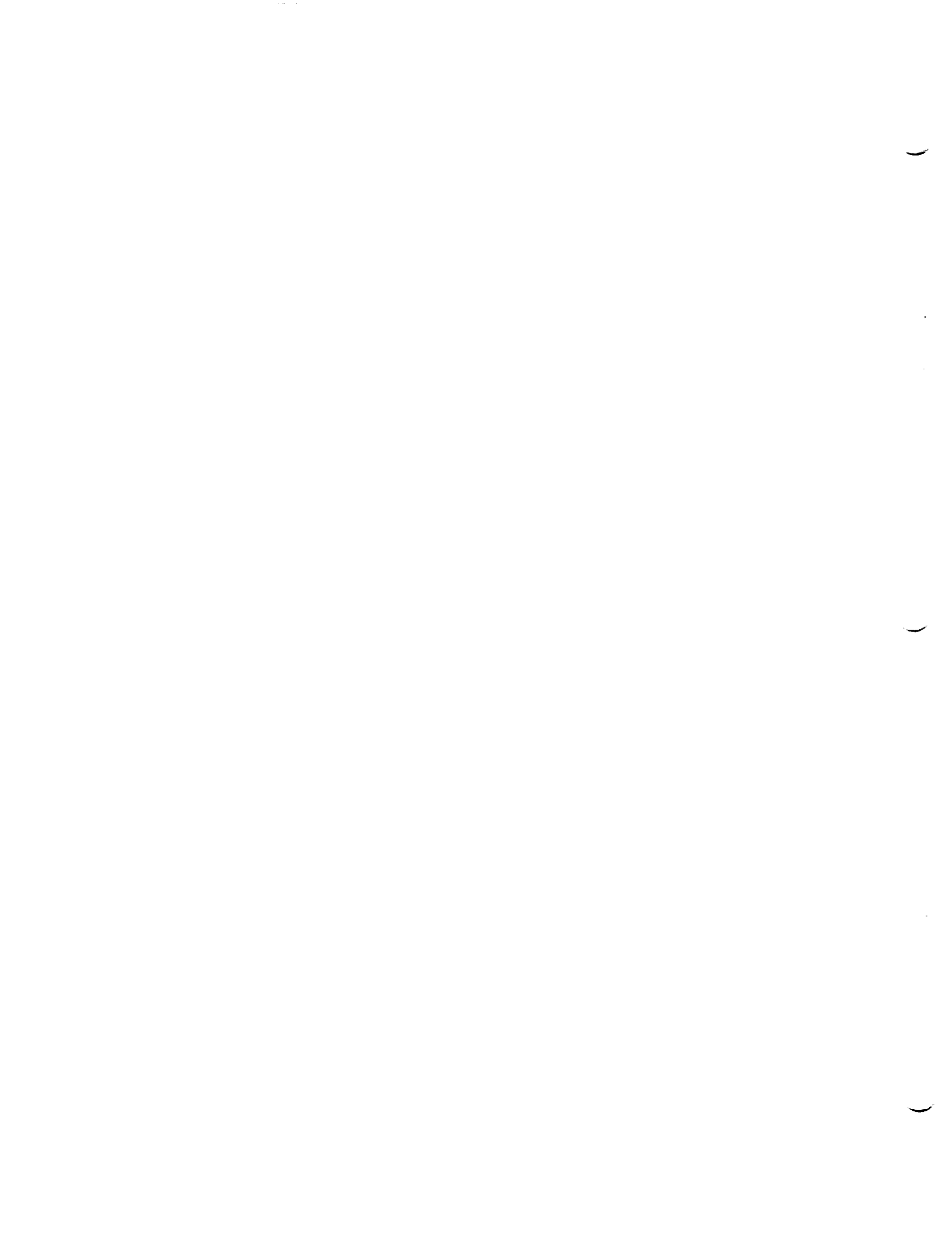
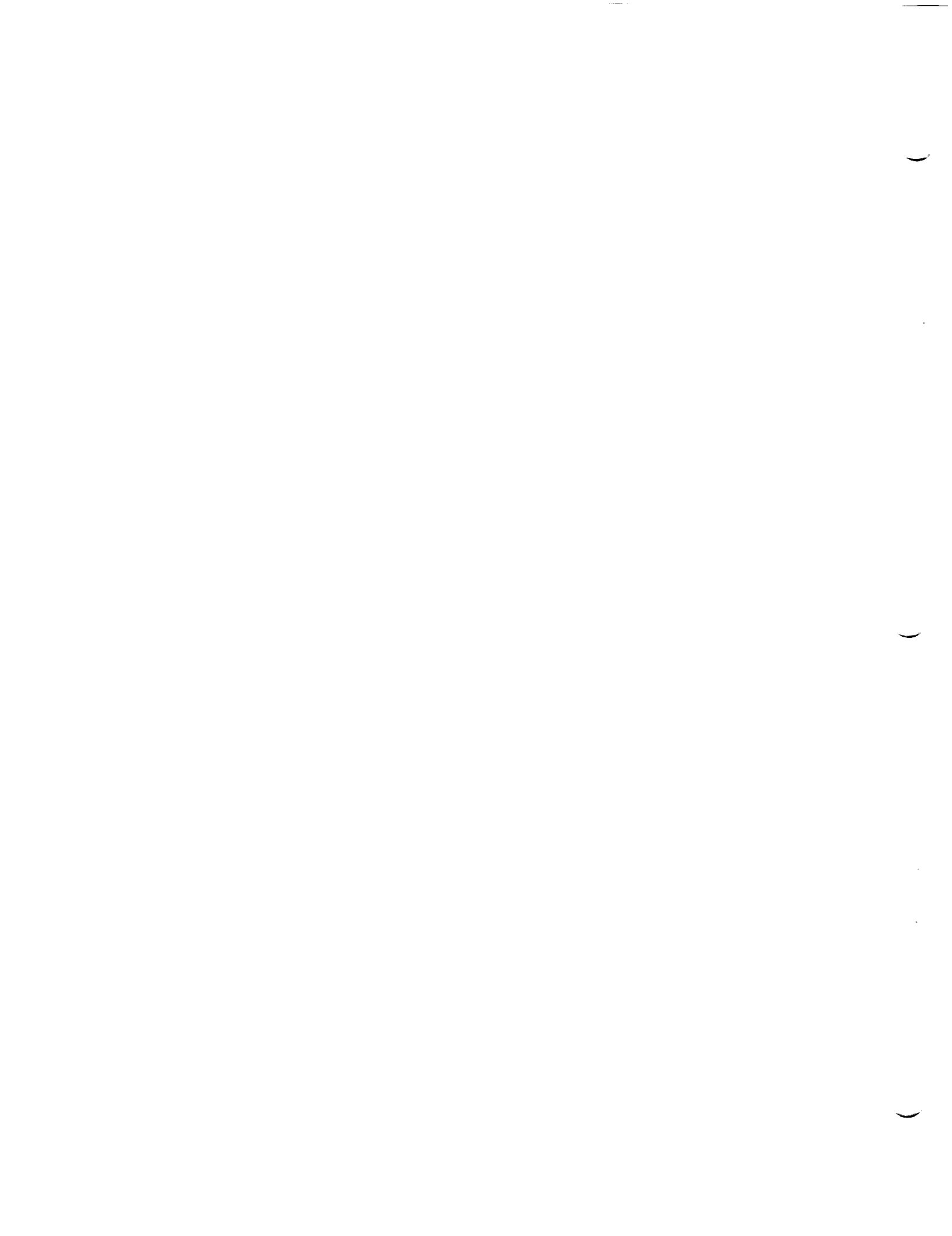



Photo 21: Overall View of Orbiter Nose



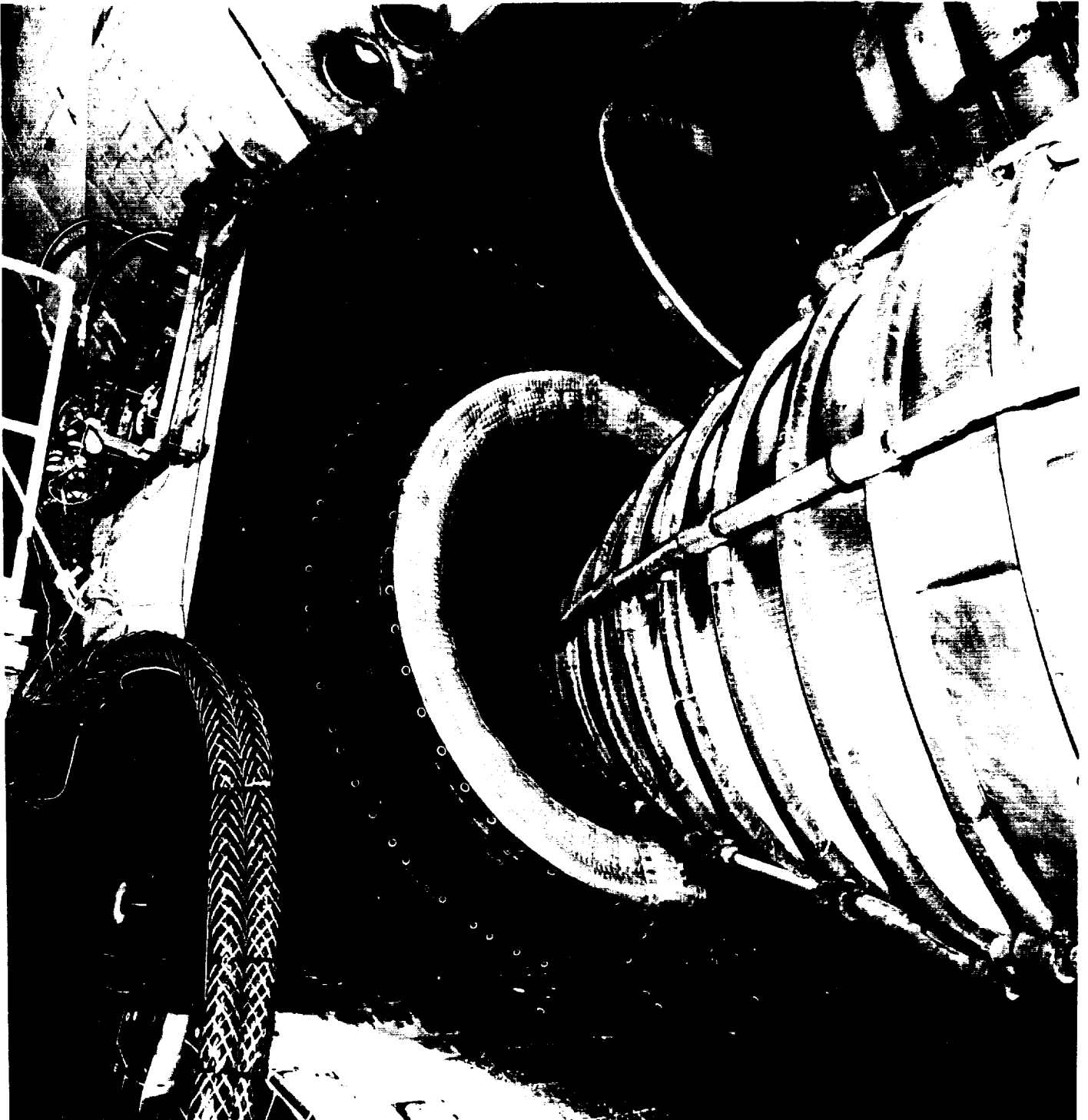
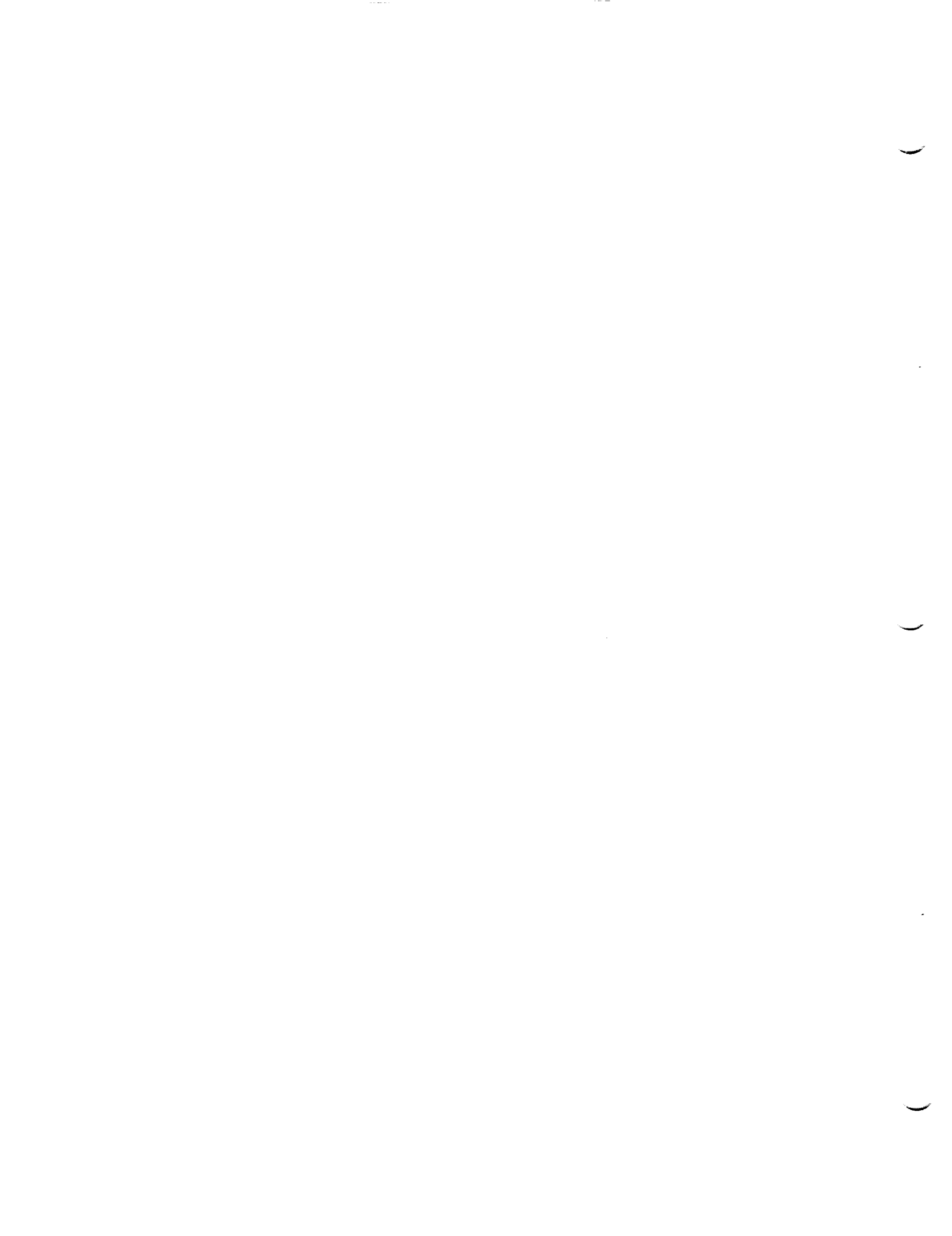

Photo 22: View of Base Heat Shield

All three Dome Mounted Heat Shield (DMHS) closeout blankets were in excellent condition with no missing material.



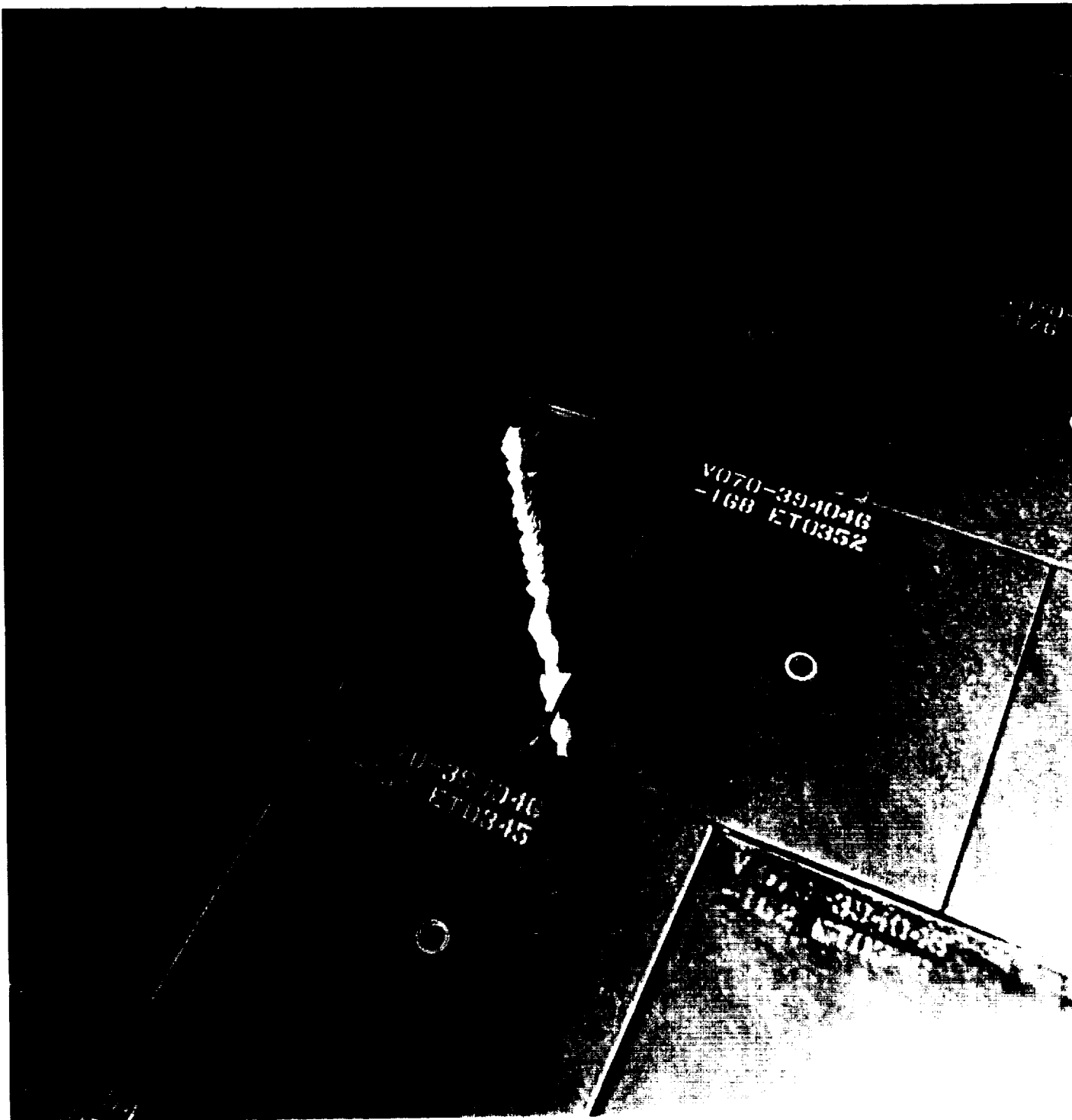

Photo 23: Lower Surface Tile Damage

The Orbiter lower surface sustained a total of 55 hits, of which 6 had a major dimension of 1-inch or larger. The largest lower surface tile damage site occurred approximately 15 feet forward of the RH MLG wheel well and measured 6.0-inches long by 0.375-inches wide by 0.25-inch maximum depth

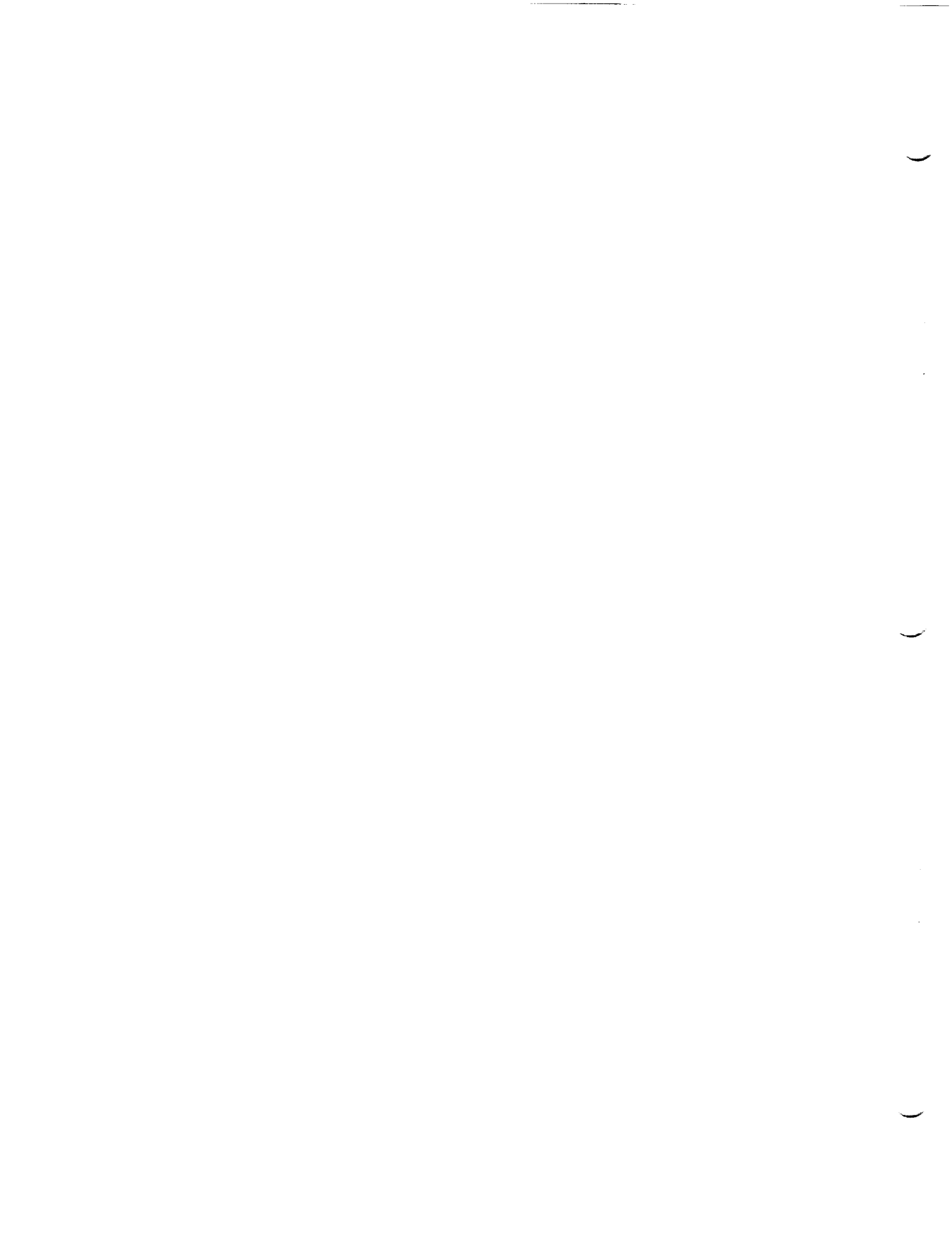



Photo 24: Debris Found on Runway Under Umbilical Cavity

The only debris found on the runway under the umbilical cavities (LH2) consisted of a bolt 0.875-inches long by 0.1875-inch diameter with a red coating on the bolt head. The bolt, which is stamped with the number MS 21279-7, is used in the Orbiter aft compartment SSME wire bundle clamps. A post flight inspection of the aft revealed no missing bolts (Ref. Lost and Found PR LAF-5-11-0199).

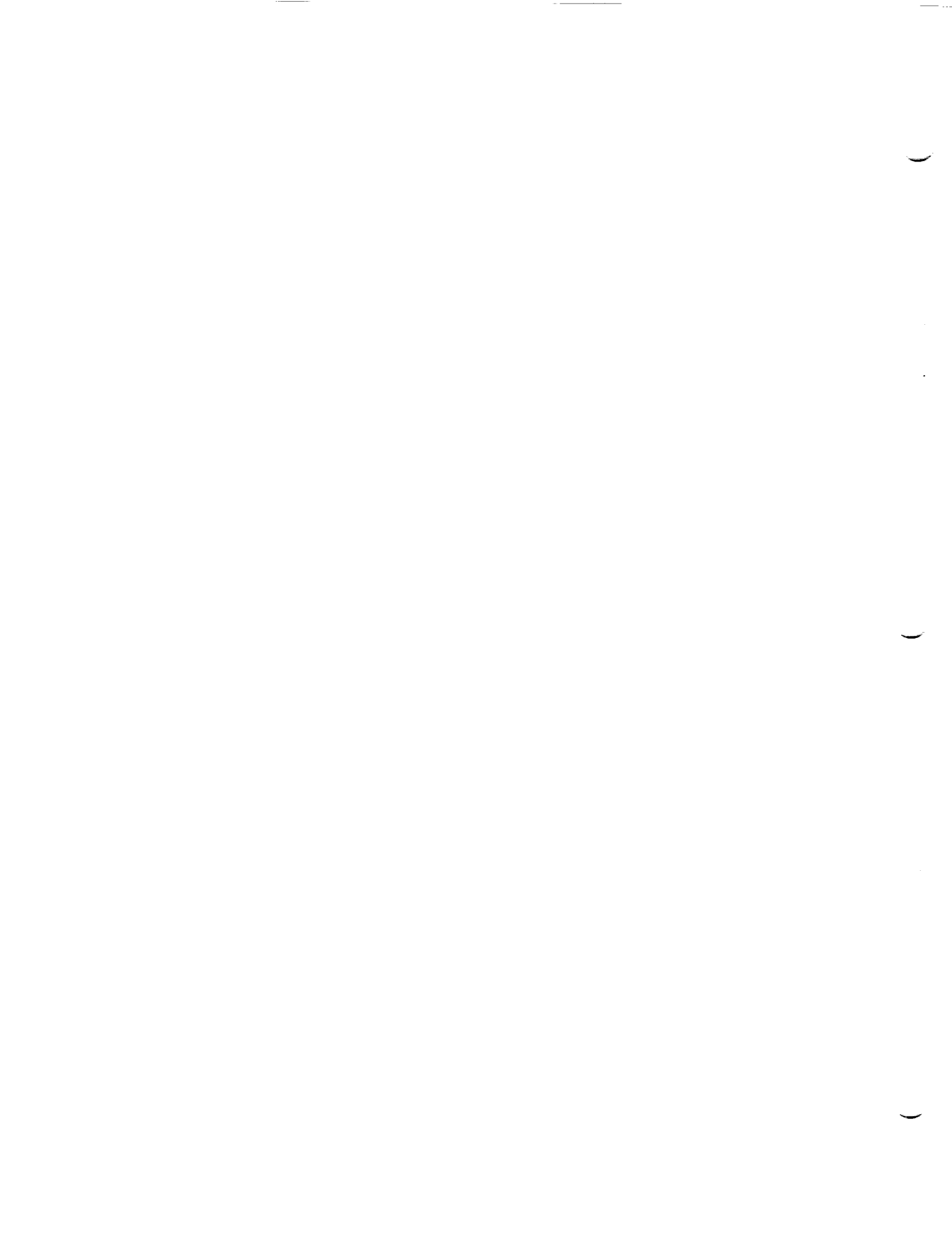



Photo 25: LO2 ET/ORB Umbilical

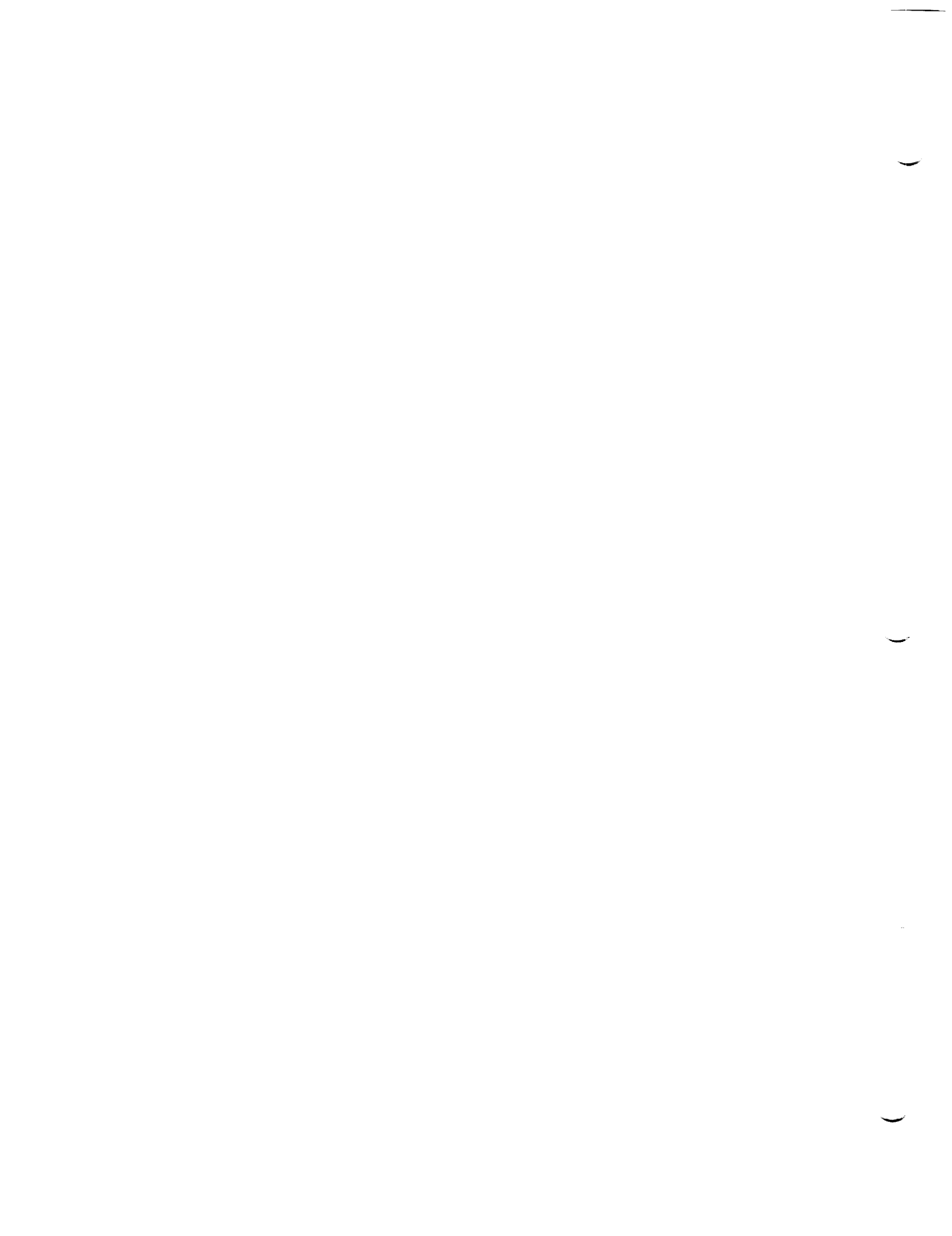



Photo 26: LH2 ET/ORB Umbilical

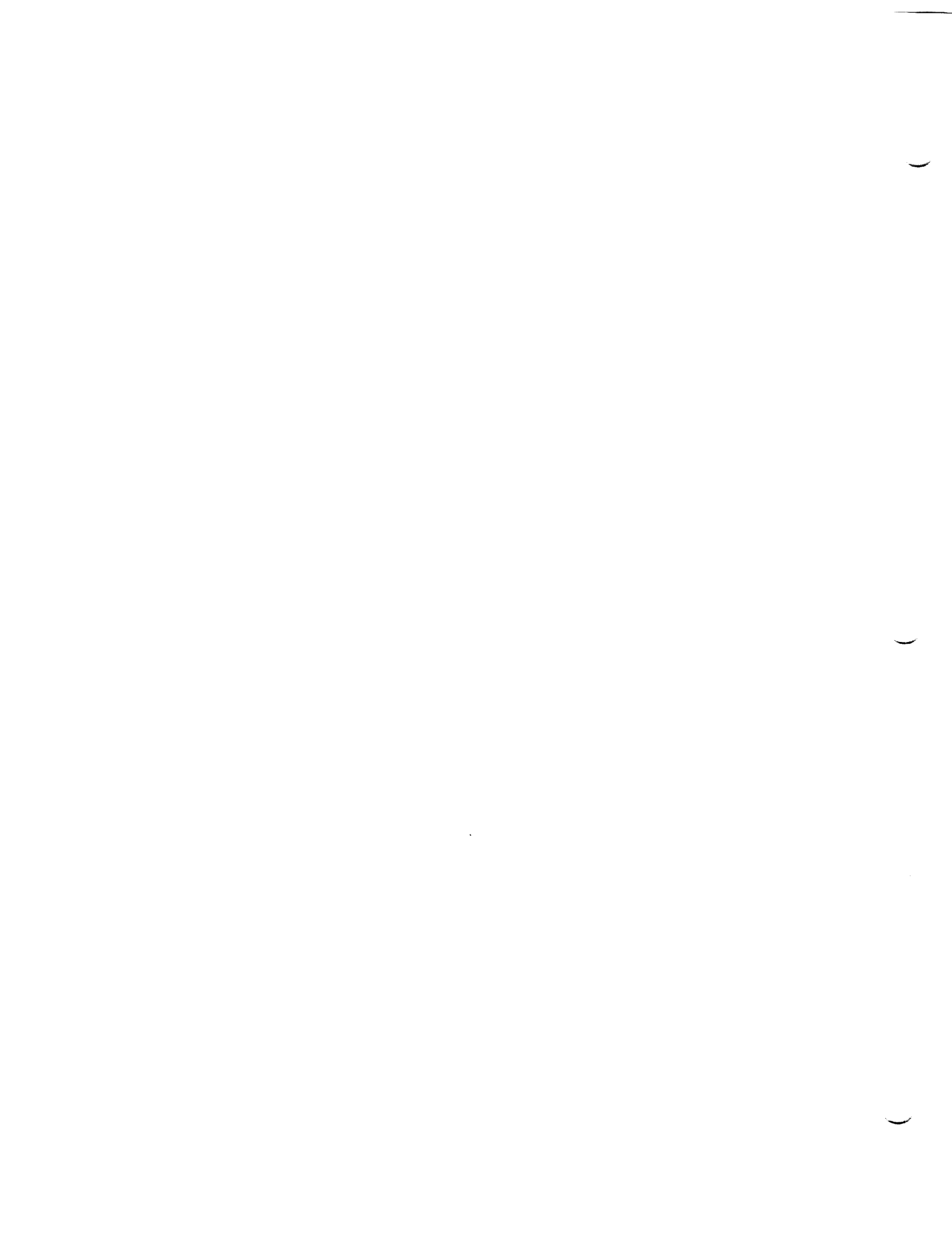

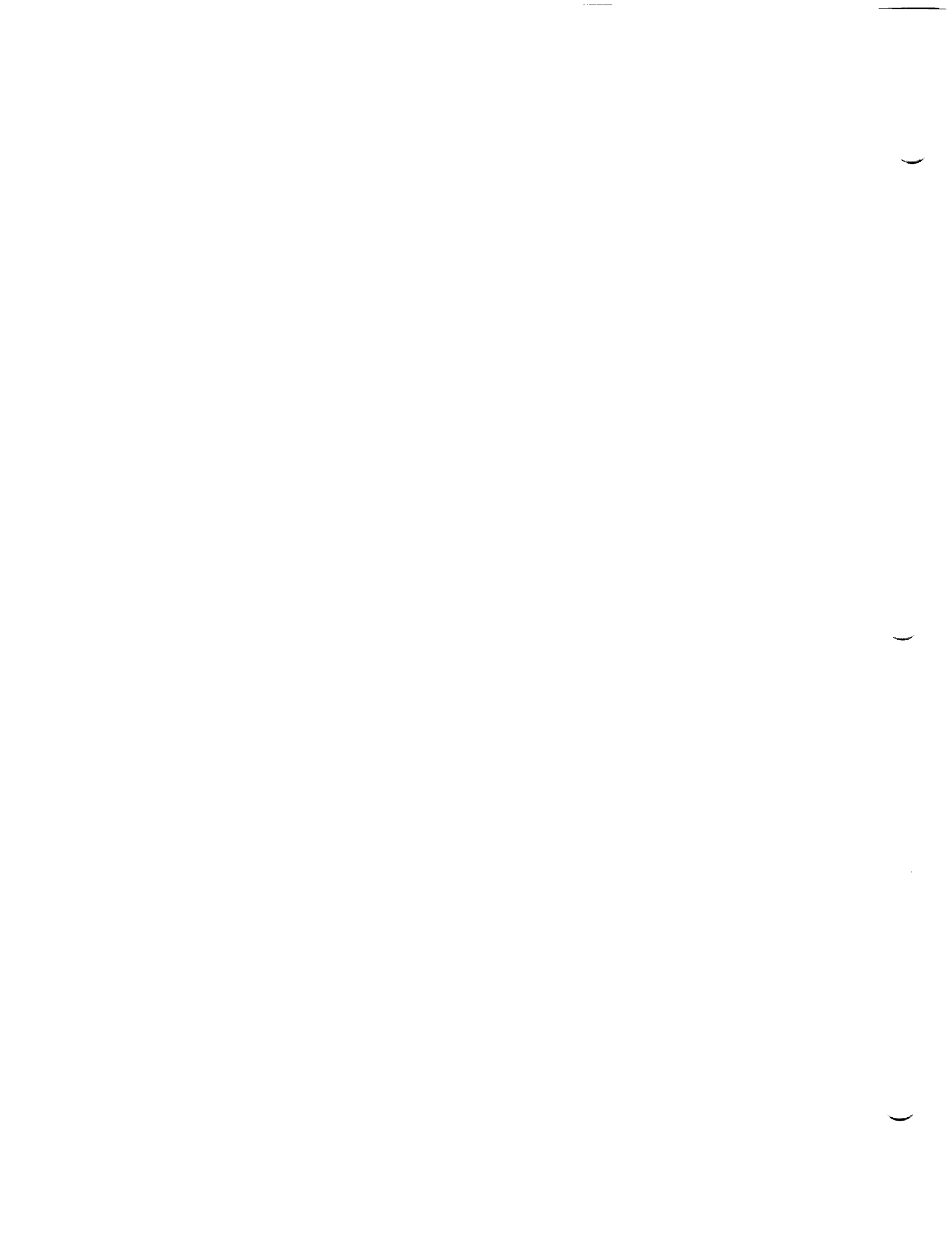

Photo 27: Orbiter Windows 1 - 3



Photo 28: Orbiter Windows 4 - 6

Less than usual hazing was visible on the Orbiter windows. Eighteen damage sites on the window perimeter tiles was most likely caused by impacts from FRCS thruster paper covers and RTV adhesive.



8.0 DEBRIS SAMPLE LAB REPORTS

A total of sixteen samples were obtained from OV-105 Endeavour during the STS-72 launch and landing activities at the Kennedy Space Center. The submitted samples consisted of 8 wipes from Orbiter windows #1-8 taken prelaunch and again at postlanding. The samples were analyzed by the NASA KSC Microchemical Analysis Branch (MAB) for material composition and comparison to known STS materials. Debris analysis involves both the placing and the correlating of particles and residues with respect to composition, thermal (mission) effects, and availability. Debris sample results/analyses are listed by Orbiter location in the following summaries.

8.1 PRELAUNCH ORBITER WINDOWS

Prelaunch samples from the Orbiter windows indicated exposure to facility environment (including metallic particulate), launch site materials (earth minerals), Orbiter Thermal Protection System (RTV, tile, tile repair, and glass insulation), Orbiter window polish residue, paints and primer from various sources. There was no apparent vehicle damage related to these residuals.

8.2 PRELAUNCH ORGANIC ANALYSIS

The results of the prelaunch STS-72 organic analysis are pending.

8.3 PRELAUNCH WINDOW COVERS

The results of the prelaunch STS-72 window cover sample analysis indicated results similar to the samples taken from the actual Orbiter windows. Evidence of exposure to the facility environment (including metallic particulate), launch site materials (earth minerals), Orbiter Thermal Protection System (excluding tile repair material), paints and primer from various sources. Orbiter window polish residue was not found in the window cover samples.

8.4 POSTLANDING ORBITER WINDOWS

Samples from the Orbiter windows indicated exposure to facility environment (including metallic particulate), landing site materials (earth minerals), Orbiter Thermal Protection System (RTV, tile, tile repair, and glass insulation), Orbiter window polish residue, paints and primer from various sources. There was no apparent vehicle damage related to these residuals.

8.5 POSTLANDING ORGANIC ANALYSIS

The results of the postlanding organic analysis are pending.

8.6 NEW FINDINGS

This set of prelaunch residual samples provided new source information for launch pad processing residual identification. The continued organic sample analysis and source data provided by the prelaunch samples will not be fully realized until STS debris chart update is completed (reference Figure 11).

STS	Sample Location	
	Wing RCC	Lower Tile Surface
72	Windows Metallics - Fac.Env./BSM Residue(SRB) RTV, Tile, Tile repair (ORB TPS) Insulation Glass (ORB TPS) Building type insulation Earth Minerals Organics Window polish residue Paint and primer	Umbilical Pre-launch Window Cover: Metallic-Fac.Env.;RTV,Tile-(TPS) Insulation Glass - (ORB TPS) Earth Minerals; Organics Pre-launch Window: Metallic-Fac.Env.;Window polish res RTV,Tile,Tile repair,Ins glass (TPS) Earth Minerals,Organics,Paint/primer
74	Metallics - Fac.Env./BSM Residue(SRB) RTV (ORB TPS) Insulation Glass (ORB TPS) Building type insulation Earth Minerals Organics - Plastic polymers, sealant, RTV(RCS thruster nozzle cover adhesive) SRB sealant Paint and primer	
73	Metallics - Fac. Env./BSM Residue (SRB) Tile, Tile filler (ORB TPS) Insulation Glass (ORB TPS) Earth Minerals Organics - Plastic polymers, sealant, RTV(RCS thruster nozzle cover adhesive) Paint and primer	
69	Metallics - Fac. Env./BSM Residue (SRB) RTV, Tile filler (ORB TPS) Insulation glass (ORB TPS) Earth minerals Building type insulation Organics -RTV(RCS adhesive),Plastic polym Orbiter window polish residue Paint and primer	
70	Metallics - Fac. Env./BSM Residue (SRB) RTV, Tile filler (ORB TPS) Insulation glass (ORB TPS) Earth minerals Building type insulation Organics - RTV, Plastic polymers RTV - RCS thruster nozzle cover adhesive Paint and primer	
71	Metallics - Fac. Env./BSM Residue (SRB) RTV, Tile, Tile filler (ORB TPS) Insulation Glass (ORB TPS) Earth minerals (landing site) Organics - Plastic polymers RTV - RCS thruster nozzle cover adhesive Paint and primer	

Figure 11: Orbiter Post Landing Microchemical Sample Results

STS	Windows	Sample Location		Other
		Wing RCC	Lower Tile Surface	
67	<p>Metallics - Fac. Env./BSM Residue (SRB) Tile, Tile filler (ORB TPS) Insulation Glass (ORB TPS) Fiber - sample cloth Earth minerals (Landing site) Organics - RTV/RCS adhesive, Plastic polymeric Paint and primer</p>			SRB sealant sample: laboratory reference
63	<p>Metallics - Fac. Env./BSM Residue (SRB) RTV, Tile, Tile filler (ORB TPS) Insulation Glass (ORB TPS) Building type insulation Fiber-sample cloth Earth minerals (Landing site) Organics-Plastic polymers, SRB sealant RTV/RCS thruster nozzle cover adhesive) Paint and primer</p>		Silica-rich tile (ORB TPS) Hypalon paint (SRB)	
66	<p>Metallics - Fac. Env./BSM Residue (SRB) RTV, Tile, Tile filler (ORB TPS) Insulation Glass (ORB TPS) Fiber-sample cloth Earth minerals (Landing site) Organics-Plastic polymers, SRB sealant RTV/RCS thruster nozzle cover adhesive) Paint and primer</p>		Silica-rich tile (ORB-TPS) Hypalon paint (SRB)	
68	<p>Metallics - Fac. Env./BSM Residue (SRB) RTV, Tile, Tile filler (ORB TPS) Insulation Glass (ORB TPS) Fiber-sample cloth Earth minerals (Landing site) Organics-Plastic polymers, SRB sealant RTV/RCS thruster nozzle cover adhesive) Paint and primer</p>		Silica-rich tile (ORB-TPS) Hypalon paint (SRB)	ET GOX Vent Seal land area and GOX Seal Sample - Metallic Particulate WINDOW DEBRIS SAMPLE - 'Butcher paper'
64	<p>Metallics - Fac. Env./BSM Residue (SRB) RTV, Tile, Tile filler (ORB TPS) Insulation Glass (ORB TPS) Fiber-sample cloth Earth minerals (Landing site) Organics-Plastic polymers, SRB sealant RTV/RCS thruster nozzle cover adhesive) Paint and primer</p>			

Figure 11 (continued): Orbiter Post Landing Microchemical Sample Results

STS	Sample Location		Other
	Window	Umbilical	
65	<p>Metallics - Fac.Env./BSM Residue (SRB) RTV, Tile, Tile filler (ORB TPS) Insulation Glass (ORB TPS) Fiber-sample cloth Earth minerals (Landing site) Organics-Plastic polymers, SRB sealant RTV/RCS thruster nozzle cover adhesive) Paint and primer</p>	<p>Lower Tile Surface Silica-rich tile (ORB-TPS) Hypalon paint (SRB)</p>	
59	<p>Metallics - Fac.Env./BSM Residue (SRB) RTV, Tile, Tile filler (ORB TPS) Insulation Glass (ORB TPS) Fiber-Building insulation, wipe cloth Earth minerals - (Landing site) Organics- Plastic polymers, sealant RTV/RCS thruster nozzle cover adhesive) Paint and primer</p>		
62	<p>Metallics - Fac.Env./BSM Residue (SRB) RTV, Tile, Tile filler (ORB TPS) Insulation Glass (ORB TPS) Fiber-Building insulation, wipe cloth Earth minerals - (Landing site) Organics- Plastic polymers, sealant RTV/RCS thruster nozzle cover adhesive) Paint and primer</p>		
60	<p>Metallics - Fac.Env./BSM Residue (SRB) RTV, Tile, Tile filler (ORB TPS) Insulation Glass (ORB TPS) Fiber - Building insulation, textile Earth minerals - (Landing site) Organics - Plastic polymers, SRB sealant RTV/RCS thruster nozzle cover adhesive) Paint and primer</p>		
61	<p>Metallics - Fac.Env./BSM Residue (SRB) RTV, Tile filler (ORB TPS) Insulation Glass (ORB TPS) Fiber - Building insulation, textile Earth minerals - (Landing site) Blue paint particles Organics - Plastic polymers, rubber RTV/RCS thruster nozzle cover adhesive) Paint and primer</p>		
58	<p>Metallics - Fac. Env./BSM Residue (SRB) RTV, Tile (ORB TPS) Insulation Glass (ORB TPS) Glass fiber - Structural insulation Earth minerals - (Landing site) Blue paint/zinc alloy Organics - Plastic polymers, adhesive RTV/RCS thruster nozzle cover adhesive) Paint</p>		

Figure 11 (continued): Orbiter Post Landing Microchemical Sample Results

9.0 POST LAUNCH ANOMALIES

Based on the debris walkdowns and film/video review, 6 post launch anomalies, but no In-Flight Anomalies (IFA's), were observed on the STS-72 mission.

9.1 LAUNCH PAD/SHUTTLE LANDING FACILITY

1. Untorqued bolts were found after launch under the raised deck at the northeast and northwest corners of the LH SRB exhaust hole. These bolts had been identified during the pre-launch pad inspection.

2. As the LH2 T-0 umbilical carrier plate retracted at T-0, a rectangular object 1.5-inches long by 1-inch wide appeared to originate from the umbilical plate cable area and fall past the Orbiter inboard elevon at 09:41:00.357 GMT. The object is most likely a metal parts tag from the carrier plate flex lines. No contact with Orbiter tiles was detected

9.2 SOLID ROCKET BOOSTERS

1. A 0.5-inch by 0.25-inch piece of ordnance debris was wedged against the HDP #4 plunger and prevented full seating.

9.3 EXTERNAL TANK

1. No significant items

9.4 ORBITER

1. A rectangular object, believed to be a base heat shield gap filler, first appeared from an area behind the body flap in the general vicinity of SSME #2 and fell aft at GMT 09:40:57.671.

2. The only debris found on the runway under the umbilical cavities (LH2) consisted of a bolt 0.875-inches long by 0.1875-inch diameter. The origin of the bolt, which is stamped with the number MS 21279-7, has not been determined yet (Ref. Lost and Found PR LAF-5-11-0199).

3. Flight hardware debris found on the runway was located in the general vicinity of the pilot chute at the 4800 foot marker. The debris consisted of a 1.25-inch long by 0.75-inch wide piece of black-coated metallic speed brake spring clip from the hinge area of the rudder near the split.



APPENDIX A. JSC PHOTOGRAPHIC ANALYSIS SUMMARY



Space Shuttle

Earth Science Branch

**Image Science and
Analysis Group**

STS-72 Summary of Significant Events

February 21, 1996

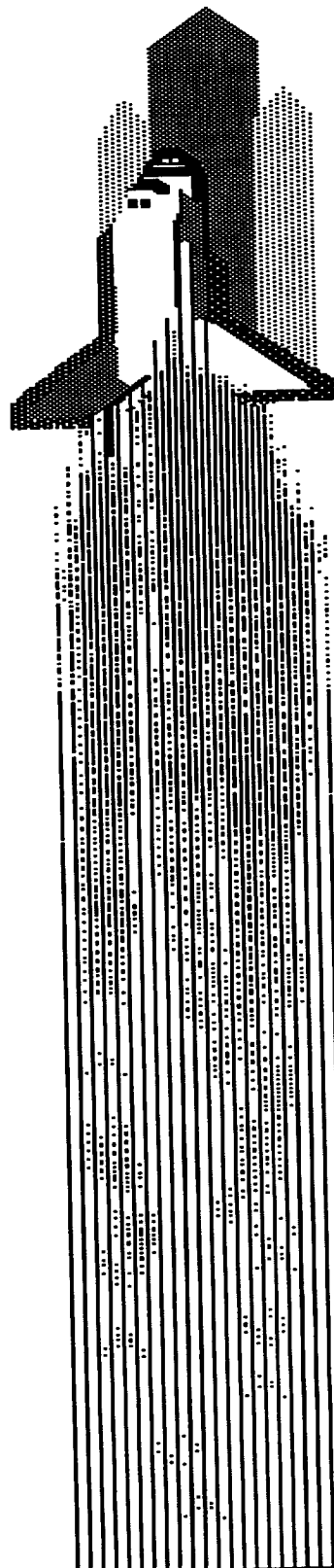

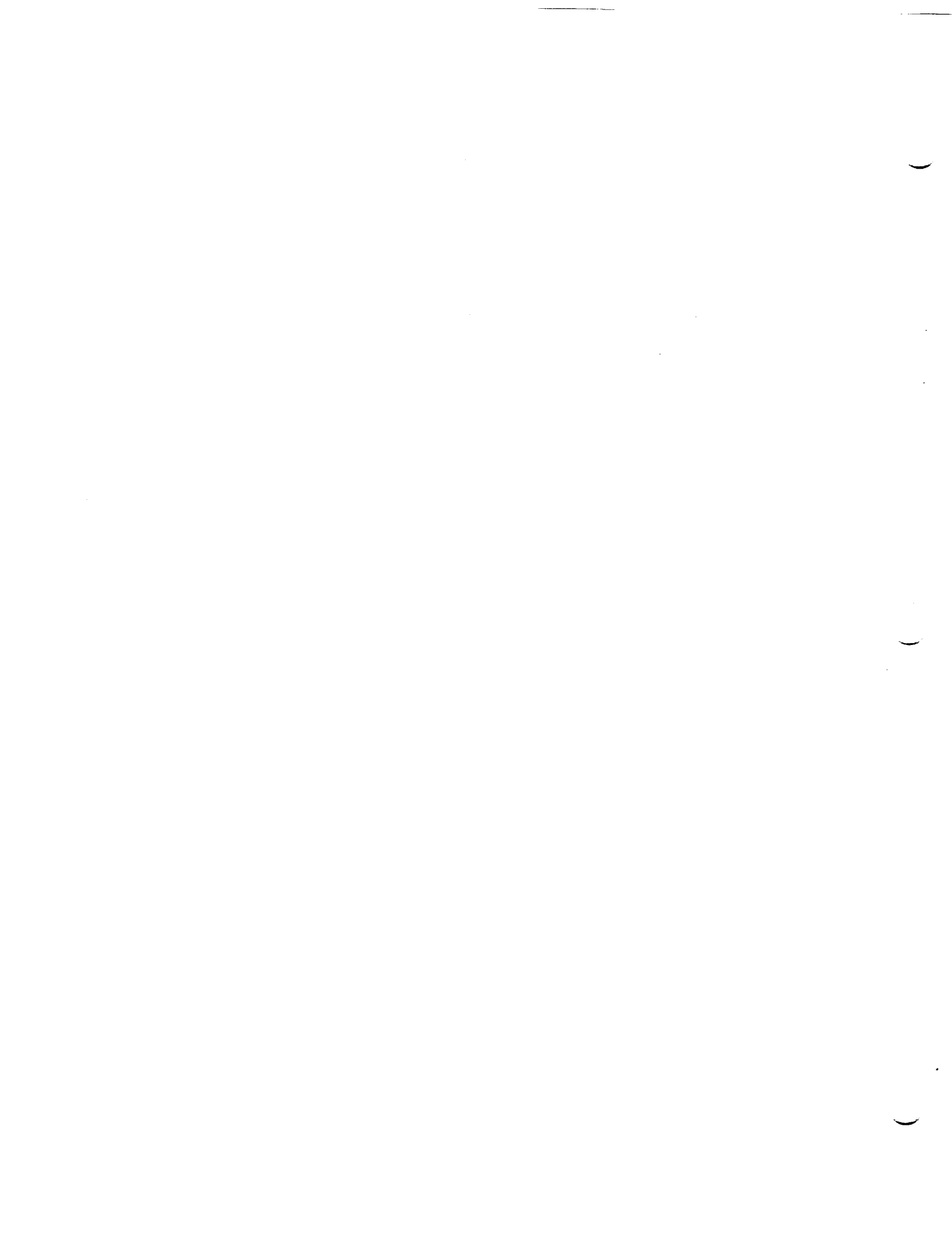

Space Shuttle Image Science and Analysis Group

STS-72 Summary of Significant Events

Project Work Order - SN-5CR

Approved By

Lockheed Martin

NASA

J. M. Disler, Project Analyst
Image Science and Analysis Group

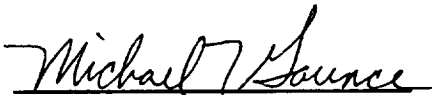
Michael T. Gaunce, Lead
Image Science and Analysis Group
Earth Science Branch

M. H. Trenchard, Project Manager
Image Analysis Projects

Jess G. Carnes, Operations Manager
Basic and Applied Research Department

Prepared By

Lockheed Martin Engineering and Sciences Company
for
Earth Science Branch
Earth Sciences and Solar System Exploration Division
Space and Life Sciences Directorate

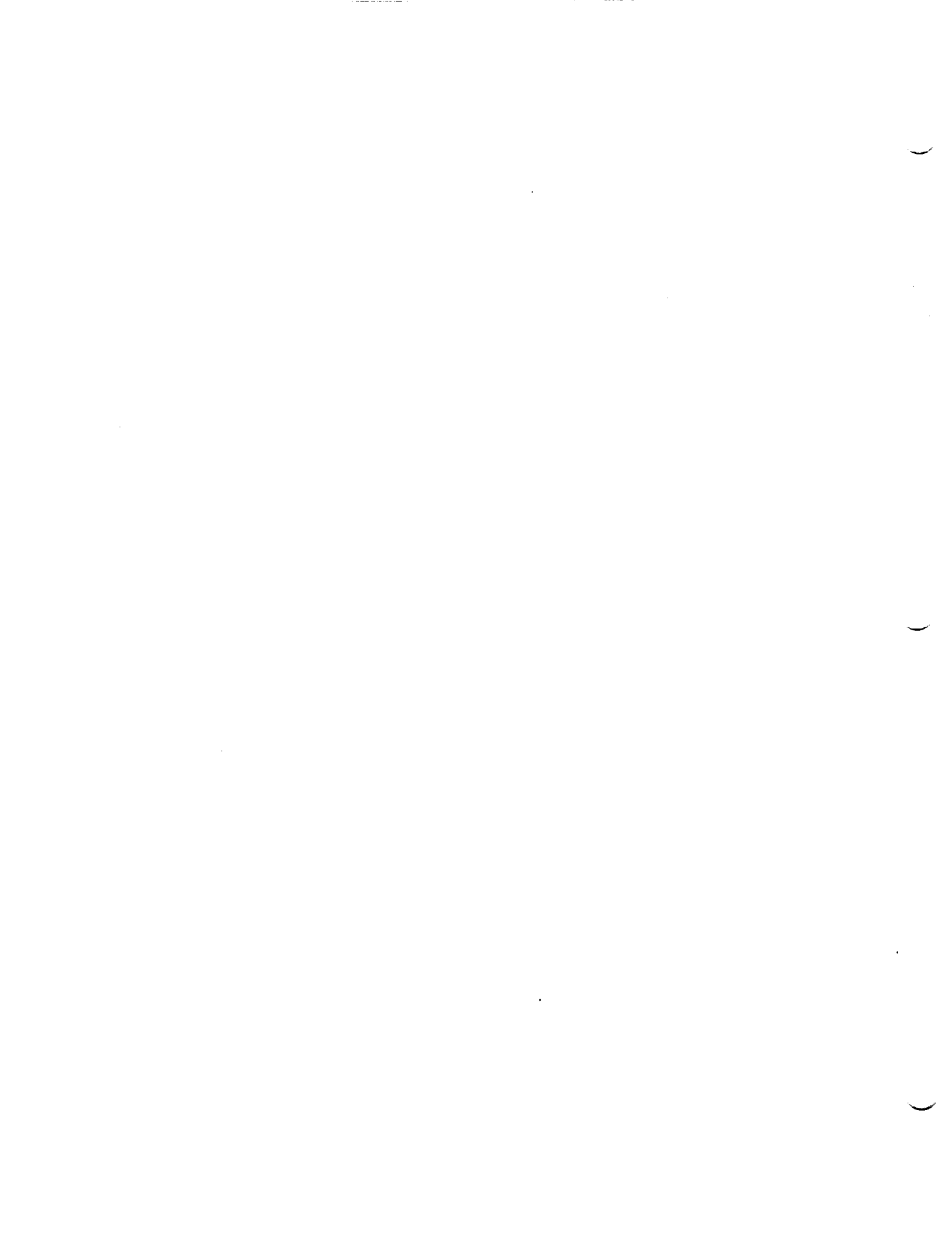

Table of Contents

1. STS-72 (OV-105): FILM / VIDEO SCREENING AND TIMING SUMMARY	A5
1.1 SCREENING ACTIVITIES	A5
1.1.1 Launch.....	A5
1.1.2 Landing	A5
1.2 TIMING ACTIVITIES.....	A5
2. SUMMARY OF SIGNIFICANT EVENTS	A7
2.1 DEBRIS.....	A7
2.1.1 Debris Near the Time of SSME Ignition	A7
2.1.1.1 Debris Strikes Orbiter Tile Aft of the LH2 Umbilical	A7
2.1.1.2 Debris Near RSRB Holddown Post M-2	A7
2.1.1.3 LH2 and LO2 ET/Orbiter Umbilical Disconnect Debris	A8
2.1.2 Debris Near the Time of SRB Ignition	A8
2.1.2.1 Water Baffle Debris	A8
2.1.2.2 Flame Trench Debris.....	A9
2.1.2.3 Debris Near Left Inboard Elevon.....	A10
2.1.2.4 Debris Near Starboard RCS Stinger.....	A11
2.1.2.5 LH2 and LO2 Tail Service Mast (TSM) T-0 Umbilical Disconnect Debris	A11
2.1.2.6 GH2 Vent Arm Debris During Disconnect and Retraction	A11
2.1.3 Debris After Liftoff.....	A11
2.1.3.1 Debris In SSME Exhaust Plume	A12
2.1.3.2 Debris Near SRB Plume	A12
2.1.3.3 Debris Near RSRB Aft Skirt.....	A12
2.2 MOBILE LAUNCH PLATFORM (MLP) EVENTS	A13
2.2.1 Object on LH2 TSM Door	A13
2.2.2 Base Heat Shield Erosion.....	A13
2.2.3 Orange Vapor.....	A13
2.2.4 SSME Mach Diamond Formation.....	A14
2.3 ASCENT EVENTS	A14
2.3.1 Flares in SSME Exhaust Plume	A14
2.3.2 Flickering Near the Starboard R2D, R3D, and R4D RCS Jets.....	A15
2.3.3 Recirculation	A16
2.4 ONBOARD PHOTOGRAPHY OF THE EXTERNAL TANK (DTO-312).....	A16
2.4.1 Analysis of Handheld Photography of the ET (Task 3).....	A16
2.4.2 Analysis of the Umbilical Well Camera Films (Task #2).....	A18
2.5 LANDING EVENTS.....	A19
2.5.1 Landing Sink Rate Analysis (Task #3)	A19
2.6 OTHER	A21
2.6.1 Normal Events.....	A21

Table of Contents

Table 1.2	Landing Video Timing Events.....	A6
Figure 2.1.1.1	Debris Strikes Orbiter	A7
Figure 2.1.2.2	Flame Trench Debris.....	A9
Figure 2.1.2.3	Debris Near Left Inboard Elevon.....	A10
Figure 2.1.2.4	Debris Near Starboard RCS Stinger.....	A11
Figure 2.1.3.2	Debris Near SRB Exhaust Plume.....	A12
Figure 2.2.3	Orange Vapor.....	A13
Figure 2.3.2	Flickering Near Starboard RCS Jets	A15
Figure 2.3.3	Recirculation	A16
Figure 2.4.1(A)	ET Separation Velocity.....	A17
Figure 2.4.1(B)	35mm Handheld (Nikon F4) External Tank Photography (DTO-312).....	A18
Figure 2.4.2	Debris Strikes LSRB (10mm Lens View).....	A19
Table 2.5.1	Sink Rate Measurements.....	A20
Figure 2.5.1	Main Gear Height Versus Time Prior To Touchdown (Film)	A20

1. STS-72 (OV-105): Film/Video Screening and Timing Summary

1. STS-72 (OV-105): FILM / VIDEO SCREENING AND TIMING SUMMARY

1.1 SCREENING ACTIVITIES

1.1.1 Launch

The STS-72 launch of Endeavour (OV-105) from pad B occurred on Thursday, January 11, 1996 (day 011) at 09:41:00.024 Coordinated Universal Time (UTC) as seen on camera E9. Solid Rocket Booster (SRB) separation occurred at 09:43:04.389 UTC as seen on camera KTV4B.

On launch day 24 of 24 expected videos were received and screened. Following launch day, 51 films were screened. Camera film E79, and E224 were not received. No potential anomalies were observed during launch.

Detailed Test Objective 312, photography of the external tank after separation, was performed using the Orbiter umbilical well cameras (method 1) and handheld photography of the external tank using the Nikon F4 with the 300mm lens plus 2X converter (method 3). Handheld video of the external tank using the Cannon L-1 camcorder was also acquired.

1.1.2 Landing

Endeavour landed on runway 15 at KSC on January 20, 1995. Twelve videos of the Orbiter's approach and landing were received. Due to the night landing only six landing films were received.

No major anomalies were noted in any of the approach, landing, or roll-out video views screened. The drag chute deployment appeared normal.

1.2 TIMING ACTIVITIES

Launch:

The time codes from videos and films were used to identify specific events during the initial screening process.

Video cameras: KTV21B did not have IRIG timing. All other videos had timing.

Film cameras: E4 and E224 did not have IRIG timing. E1, E2, E3, E5, E6, E7, E8, E9, E10, E11, E12, E13, E14, E15, E16, E17, E18, E19, E20, E25, E26, E30, E33, E34, E35, E36, E40, E50, E52, E54, E57, E59, E60, E62, E63, E65, E76, E77, and E222 had in-frame alphanumeric timing.

1. STS-72 (OV-105): Film/Video Screening and Timing Summary

Landing:

Video cameras: Twelve videos were screened on landing day. Eight videos: KTV5L, KTV6L, KTV11L, KTV15L, KTV20L, EL17 IR, EL18 IR, and SLF South had timing. There was no IRIG timing for videos SLF North, KTV33L, BMDO IR, and BMDO IN.

Film cameras: Film cameras EL1, EL7, EL 9, EL12, and EL15 had in-frame alphanumeric timing.

The landing and drag chute event times are provided in Table 1.2.

Event Description	Time (UTC)	Camera
Landing Gear - Doors Opened	020:07:41:17.374	EL18 IR
Left Main Wheel Touchdown	020:07:41:39.854	EL18 IR
Right Main Wheel Touchdown	020:07:41:39.954	EL18 IR
Drag Chute Initiation	020:07:41:42.979	KTV11L
Pilot Chute at Full Inflation	020:07:41:43.797	KTV11L
Bag Release	020:07:41:44.497	KTV11L
Drag Chute Inflation in Reefed Configuration	020:07:41:45.589	KTV11L
Drag Chute Inflation in Disreefed Configuration	020:07:41:48.752	KTV11L
Nose Wheel Touchdown	020:07:41:50.663	EL18 IR
Drag Chute Release	020:07:42:17.231	EL18 IR
Wheel stop	020:07:42:45.263	EL18 IR

Table 1.2 Landing Video Timing Events

2. Summary of Significant Events

2. SUMMARY OF SIGNIFICANT EVENTS

2.1 DEBRIS

2.1.1 Debris Near the Time of SSME Ignition

As on previous missions, multiple pieces of debris were seen near the time of SSME ignition. Most of the debris was umbilical ice and RCS paper. No follow-up action was requested.

2.1.1.1 Debris Strikes Orbiter Tile Aft of the LH2 Umbilical (Camera: OTV109)

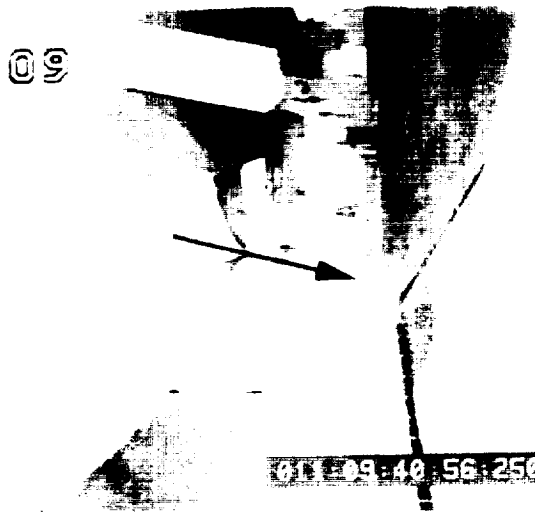

Figure 2.1.1.1 Debris Strikes Orbiter

A single light colored piece of debris (probably ice) hit the Orbiter tile surface aft of the LH2 umbilical at SSME ignition (011:09:40:56.250 UTC). No damage to the vehicle was noted.

2.1.1.2 Debris Near RSRB Holddown Post M-2 (Camera: E8)

A dark piece of debris was seen near the RSRB holddown post M-2 during SSME ignition. The debris did not appear to strike the vehicle.



2. Summary of Significant Events

2.1.1.3 LH2 and LO2 ET/Orbiter Umbilical Disconnect Debris

(Cameras: E1, E2, E17, E18, E19, E20, E36, E76, E77, E79, OTV109, OTV149, OTV150, OTV151, OTV154, OTV170, OTV171)

Normal ice debris was seen falling from the LH2 and LO2 ET/Orbiter umbilical disconnect areas at liftoff. No follow-up action was requested.

2.1.2 Debris Near the Time of SRB Ignition

As on previous missions, multiple pieces of debris were seen near the time of SRB ignition. No follow-up action was requested.

2.1.2.1 Water Baffle Debris

(Camera: E12, E15)

A single, large, orange colored piece of debris (possible water baffle material) was seen near the LSRB holddown post M-5 (09:41:00.536 UTC). Also, two large red colored pieces of debris (possible water baffle material) were seen in the exhaust cloud near the RSRB exhaust duct (09:41:01.597 UTC). The debris did not appear to strike the vehicle.

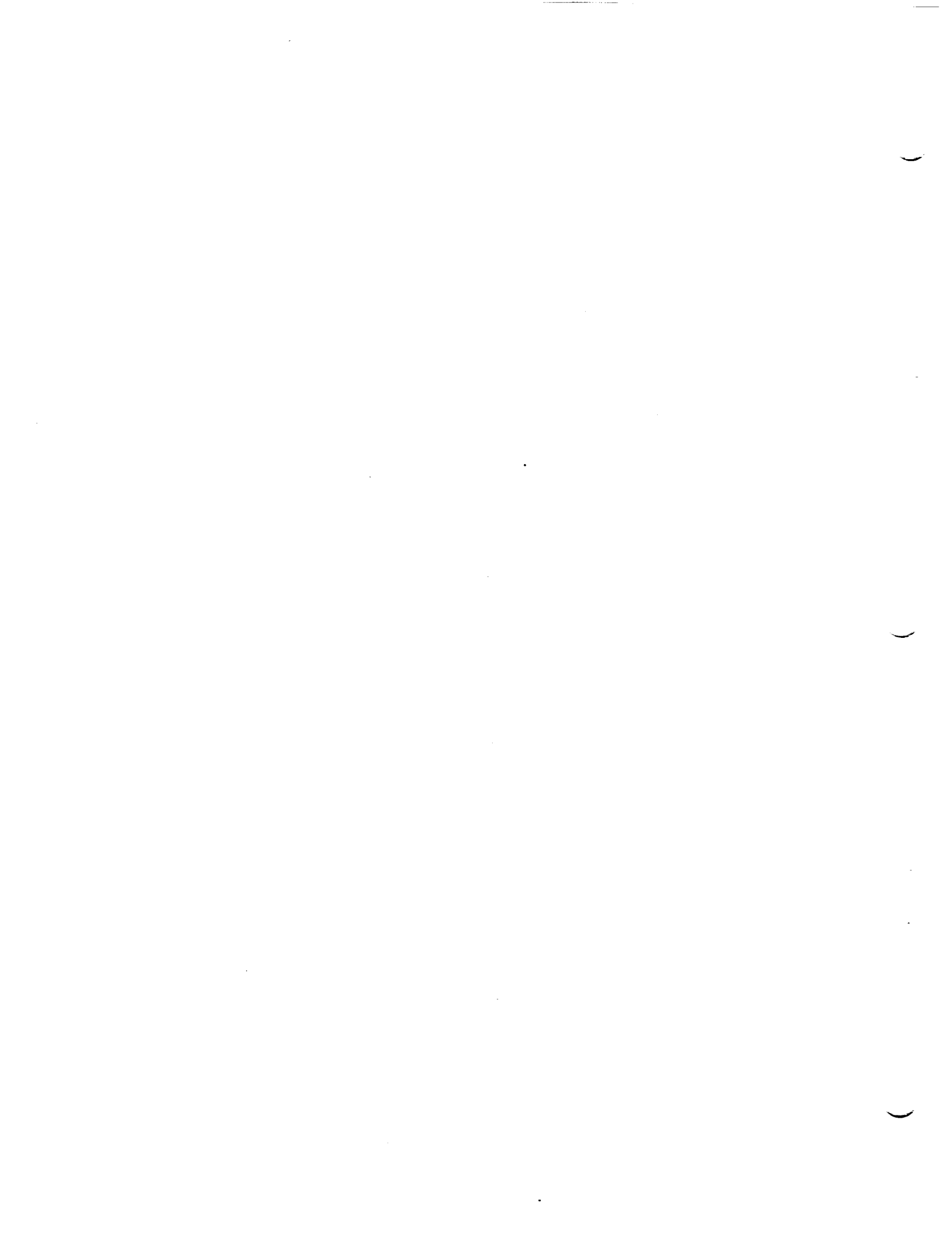

2. Summary of Significant Events

2.1.2.2 Flame Trench Debris (Camera: KTV4B, KTV7B, E4, E15, E16)



Figure 2.1.2.2 Flame Trench Debris

Several pieces of flame trench debris were seen north of the vehicle at SRB ignition (011:09:41:01.232 UTC). The debris moved north away from the vehicle and was not seen to strike the vehicle.

—

.

.

—

.

.

—

2. Summary of Significant Events

2.1.2.3 Debris Near Left Inboard Elevon (Camera: E31)



Figure 2.1.2.3 Debris Near Left Inboard Elevon

A single light colored piece of debris, rectangular in shape, was first seen on the +Z side of the left inboard elevon and moved towards the LH2 TSM at liftoff. The origin of this debris was not determined. The debris was not seen to contact the vehicle. No follow-up action was requested.

1

.

.

2

.

3

2. Summary of Significant Events

2.1.2.4 Debris Near Starboard RCS Stinger (Camera: OTV170)

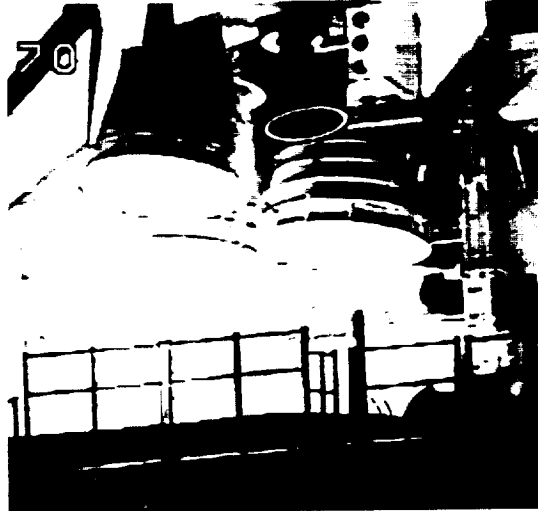

Figure 2.1.2.4 Debris Near Starboard RCS Stinger

A large, thin, rectangular piece of RCS paper fell from the starboard RCS stinger at liftoff (011:09:41:00.693 UTC).

2.1.2.5 LH2 and LO2 Tail Service Mast (TSM) T-0 Umbilical Disconnect Debris (Cameras: OTV109, OTV149, OTV150, OTV151, OTV163, OTV170, OTV171, E17, E18, E19, E20, E76, E77)

Normal ice debris was noted falling from the LH2 and LO2 TSM T-0 umbilical disconnect areas at liftoff. None of the debris was observed to strike the vehicle.

2.1.2.6 GH2 Vent Arm Debris During Disconnect and Retraction (Cameras: E33, E34, E35, E41, E50, E54)

Vapor and multiple light colored pieces of ice debris fell from the GH2 vent arm carrier plate at vent arm retraction. The GH2 vent arm appeared to retract normally.

2.1.3 Debris After Liftoff (Camera: E40, E52, E57, E59, E213, E220, E222, E223)

Multiple pieces of debris were seen falling aft of the Shuttle Launch Vehicle (SLV) after liftoff on the launch tracking views. The debris was probably reaction control system (RCS) paper and ice from the ET/Orbiter umbilicals. None of the debris was seen to contact the launch vehicle. No follow-up action was requested.

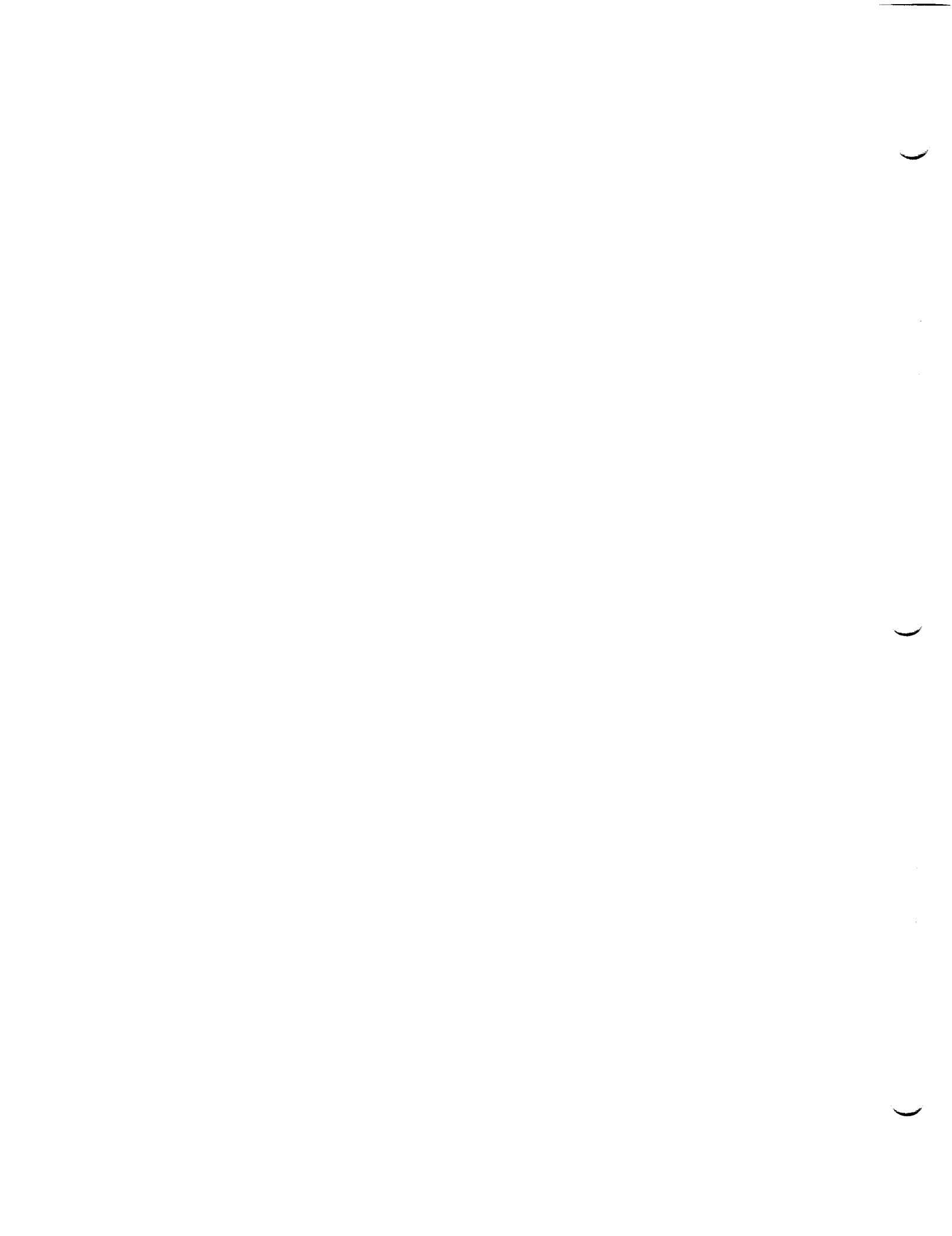

2. Summary of Significant Events

2.1.3.1 Debris In SSME Exhaust Plume

(Camera: E52, E57, E220, E222, E223)

A large piece of light colored debris was seen in the SSME exhaust plume after liftoff (09:41:08.044 UTC). Multiple light colored pieces of debris were also seen falling aft of the vehicle into the SSME exhaust plume after the roll maneuver (~09:41:29, ~09:41:41 UTC).

2.1.3.2 Debris Near SRB Plume

(Camera: E57, E59, E220, E222)

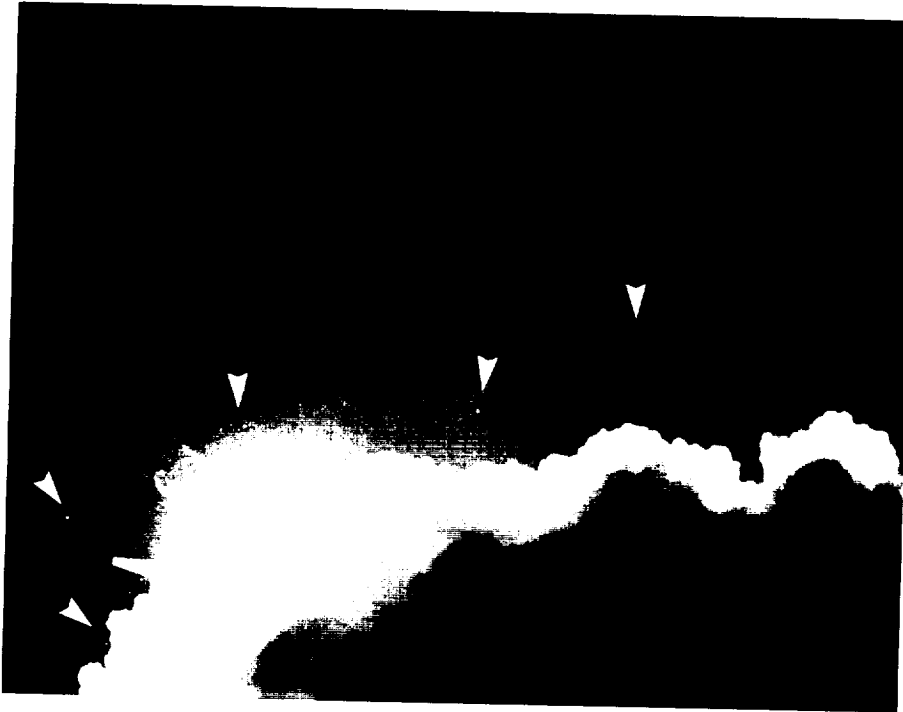

Figure 2.1.3.2 Debris Near SRB Exhaust Plume

Multiple (20 or more) pieces of light colored debris were seen near the SRB exhaust plume after the roll maneuver (09:41:14.2 - 09:41:21.7 UTC).

2.1.3.3 Debris Near RSRB Aft Skirt

(Camera: E222)

A single large appearing, light colored piece of debris was seen near the RSRB aft skirt and fell into the SSME plumes (09:41:26.773 UTC).

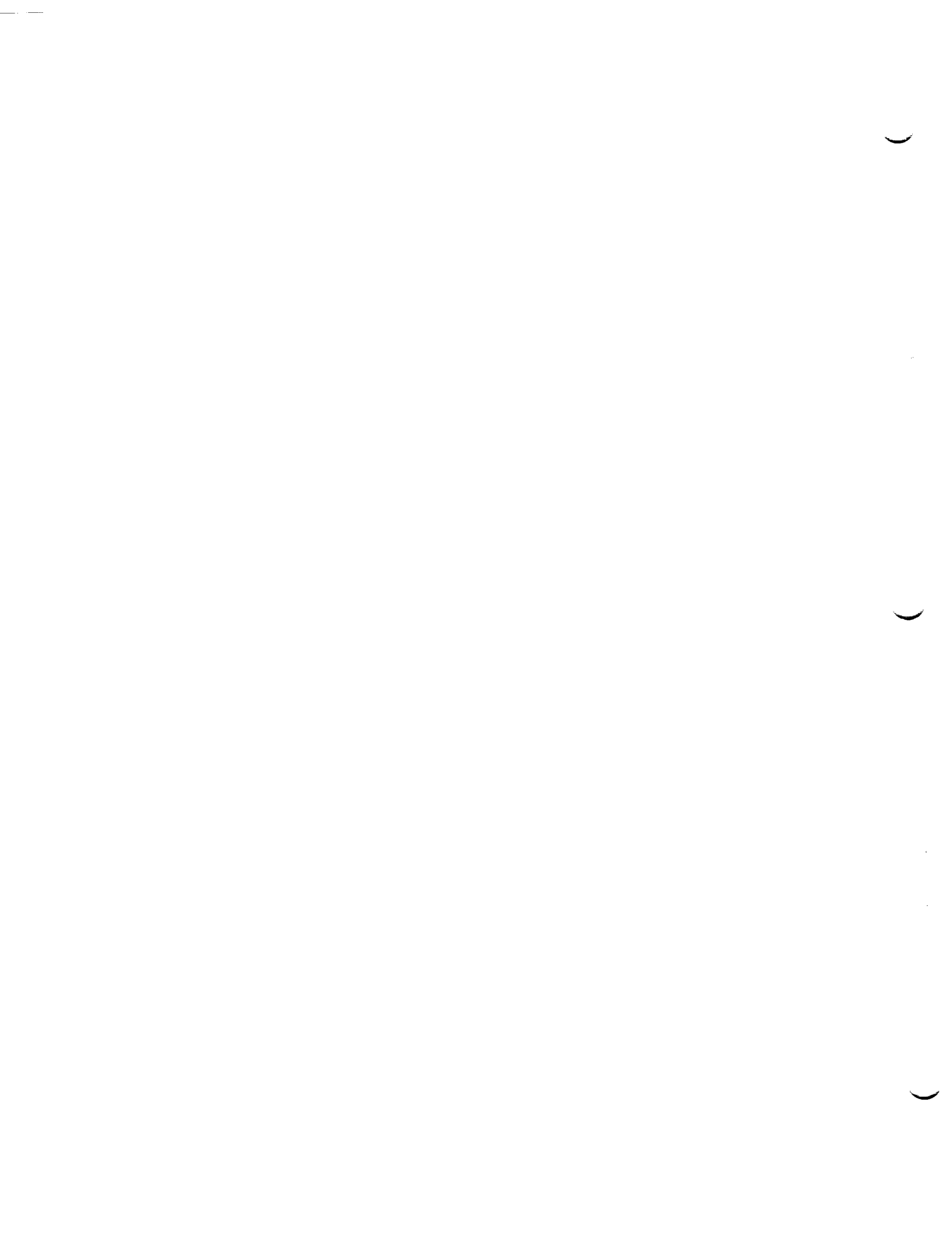

2. Summary of Significant Events

2.2 MOBILE LAUNCH PLATFORM (MLP) EVENTS

2.2.1 Object on LH2 TSM Door

(Camera: E19)

A white strap like object (possible TSM door seal material) was seen on the exterior of the LH2 TSM door during door closure at liftoff (09:41:01.319 UTC). KSC reported that this object was a piece of the clear purge barrier material. This is a normal condition and no follow-up action was required.

2.2.2 Base Heat Shield Erosion

(Camera: E18, E20)

Two areas of base heat shield erosion were noted near the base of SSME #2 during SSME ignition. Base heat shield erosion was also seen between the right RCS stinger and the base of the right OMS pod (09:40:56.411 UTC). Base heat shield erosion has been seen on previous missions. No follow-up action was requested.

2.2.3 Orange Vapor

(Cameras: E2, E3, E5, E15, E16, E17, E18, E19, E30, E36, E76, E77, OTV170, OTV171)

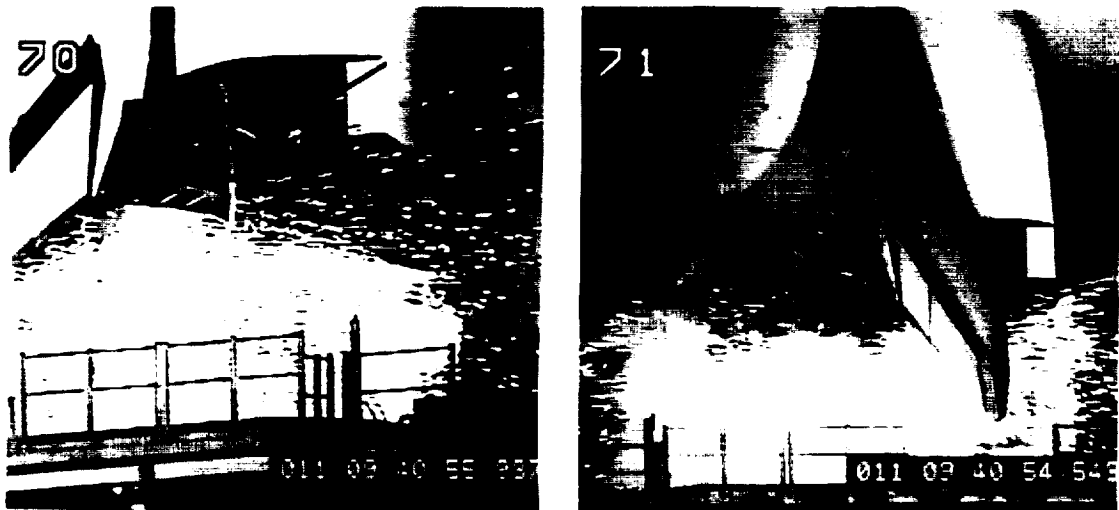

Figure 2.2.3 Orange Vapor

Orange vapor (possible free burning hydrogen) was seen above the SSME bells, by the port RCS stringer, under the bodyflap, near the vertical stabilizer and near the base heat shield during SSME ignition (09:40:54.2 UTC). Orange vapor has been seen on previous missions. No follow-up action was requested.

1

2

3

4

5

2. Summary of Significant Events

2.2.4 SSME Mach Diamond Formation

(Cameras: OTV170, OTV171, E19, E76)

The SSME Mach Diamonds formed in the normal sequence. The times of the Mach Diamond sequence were:

SSME #3 - 011:09:40:56.822 UTC

SSME #2 - 011:09:40:56.850 UTC

SSME #1 - 011:09:40:56.889 UTC

2.3 ASCENT EVENTS

2.3.1 Flares in SSME Exhaust Plume

(Cameras: KTV21B, ET212, E207, E220, E223)

Several flares were seen in the SSME exhaust plume after the roll maneuver (09:41:22 - 09:41:26 UTC). Flares in the SSME exhaust plume have been seen on previous missions. No follow-up action was requested.



2. Summary of Significant Events

2.3.2 Flickering Near the Starboard R2D, R3D, and R4D RCS Jets (Camera: E207)

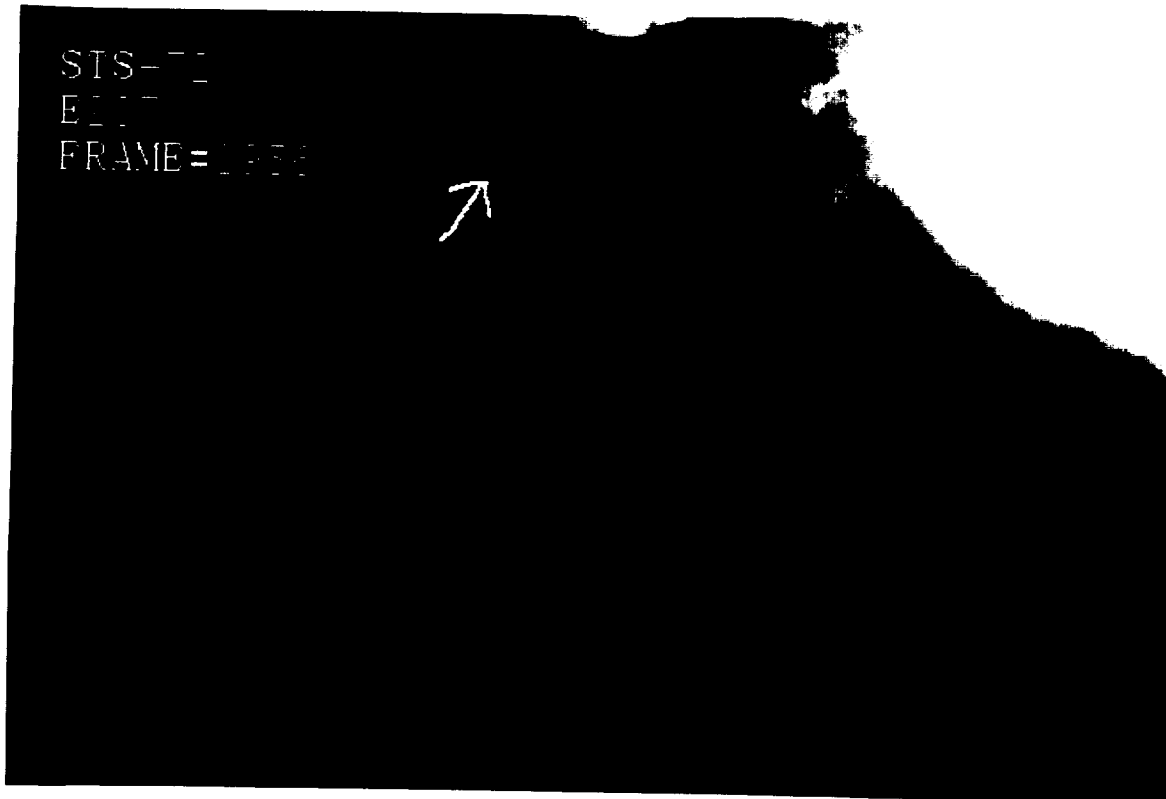
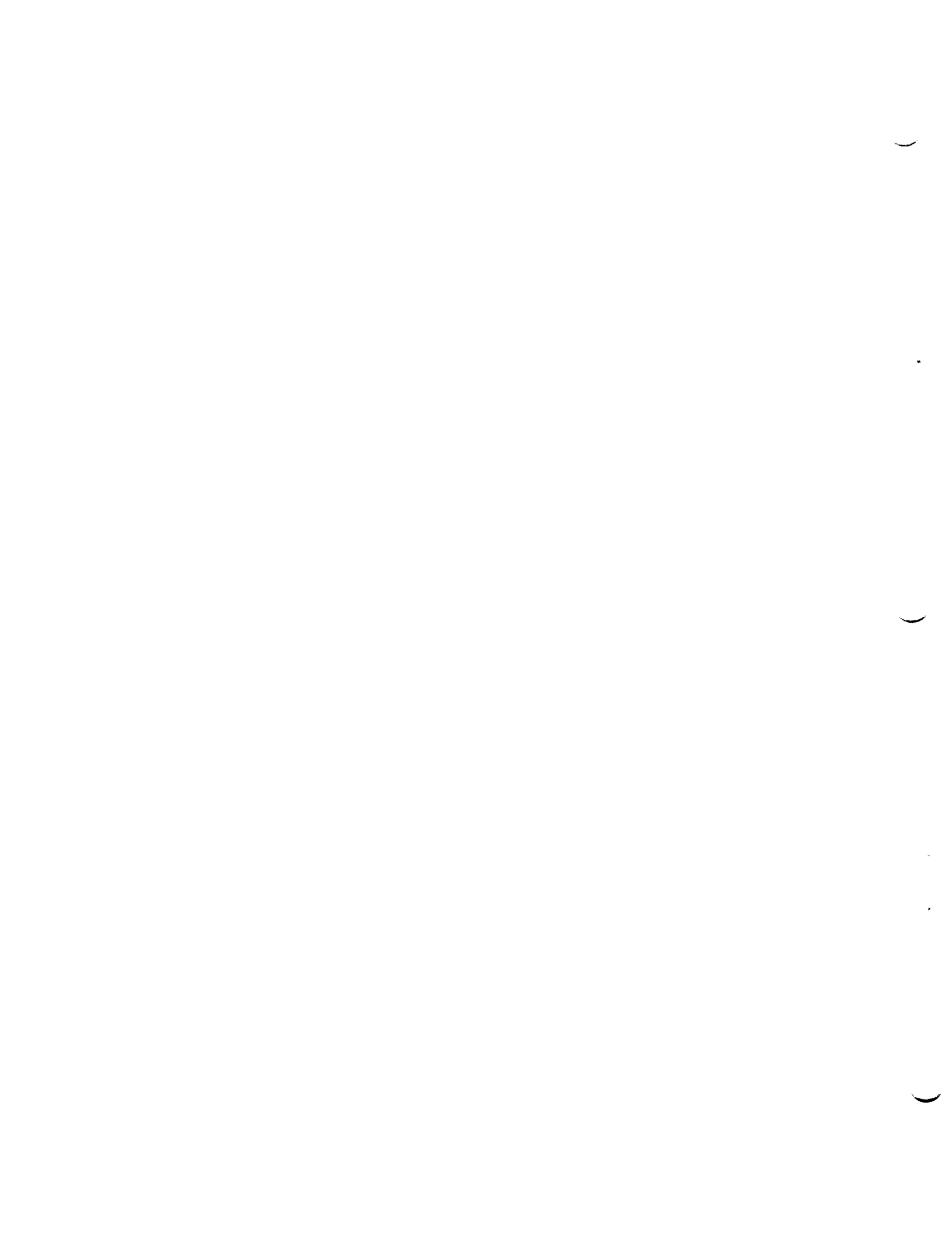

Figure 2.3.2 Flickering Near Starboard RCS Jets

An unidentified (apparent) flickering was seen near the starboard R2D, R3D, and R4D RCS jets between 19 and 21 seconds MET.

Previous night mission films were reviewed and a similar event was seen on STS-61. An analysis of the more detailed view visible on STS-61 indicated that the apparent flickering may be an optical effect. No follow-up action was requested.



2. Summary of Significant Events

2.3.3 Recirculation

(Camera: KTV13, ET204, ET212, E204, E208, E212, E218)

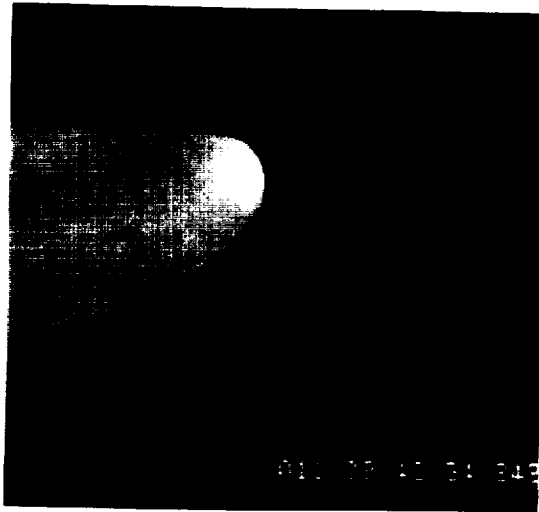

Figure 2.3.3 Recirculation

Recirculation of plasma/flame near the ET aft dome was seen after the roll maneuver (011:09:42:32 - 011:09:42:52.3 UTC). Recirculation has been seen on previous missions. No follow-up action was requested.

2.4 ONBOARD PHOTOGRAPHY OF THE EXTERNAL TANK (DTO-312)

2.4.1 Analysis of Handheld Photography of the ET (Task 3)

One roll of STS-72 handheld photography was taken using the Nikon F4 with the 300mm lens plus 2X extender (method 3). Nine usable frames were acquired for analysis.

1

2

3

4

5

6

2. Summary of Significant Events

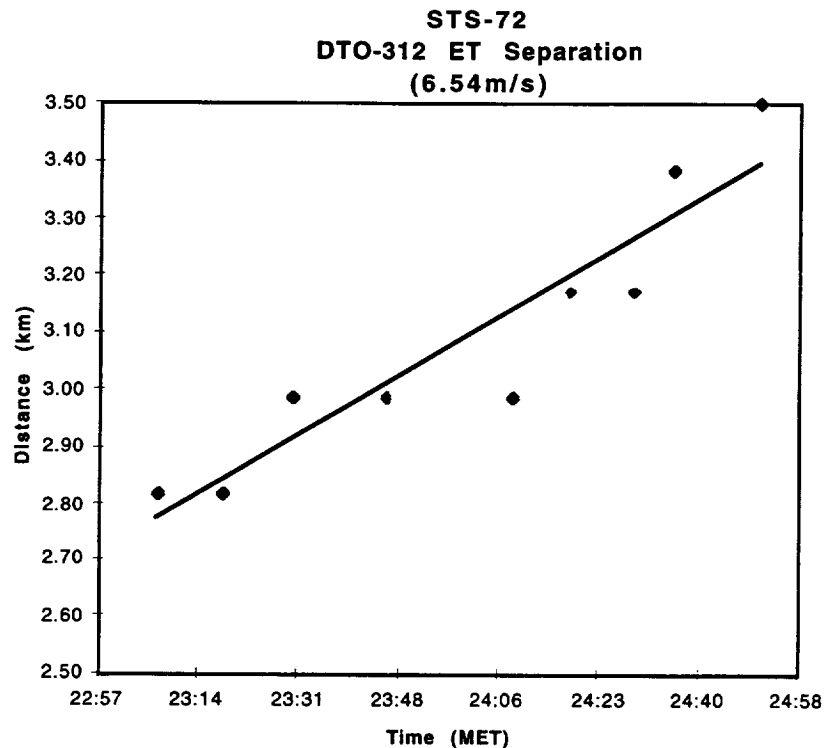
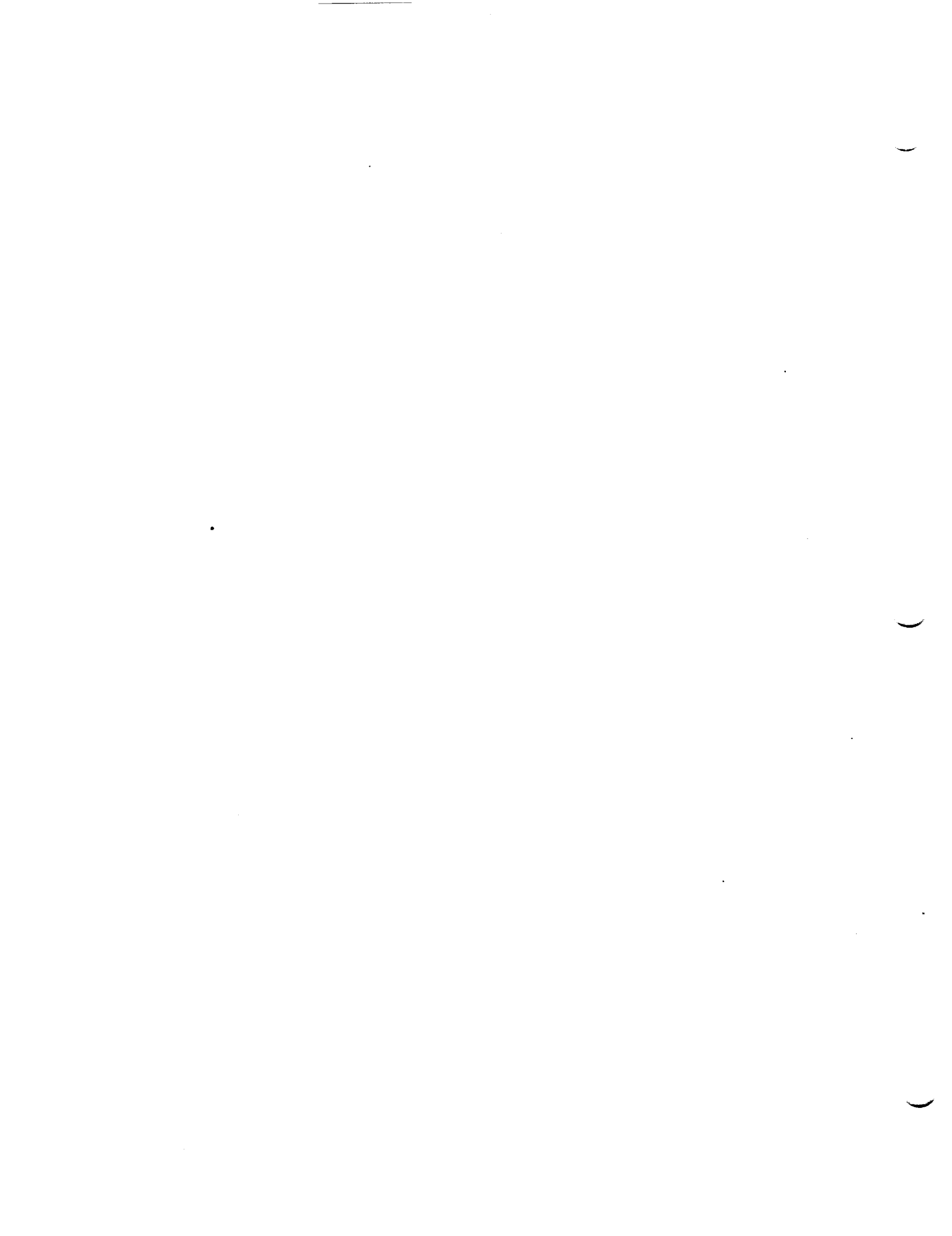

Figure 2.4.1(A) ET Separation Velocity.

Using the 35mm handheld (Nikon F4) camera film, the external tank distance was calculated over a 9 frame sequence. The external tank was calculated to be a distance of 2.8km away from the Orbiter at 23:07 MET; 104 seconds later at 24:51 MET the tank was calculated to be at 3.5km. The tank separation velocity was determined to be 6.54 m/s. Roll rate was estimated at 0.6°/sec, and tumble rate was estimated at 0.4°/sec. The separation velocity and roll/tumble rates were similar to previous mission measurements.



2. Summary of Significant Events

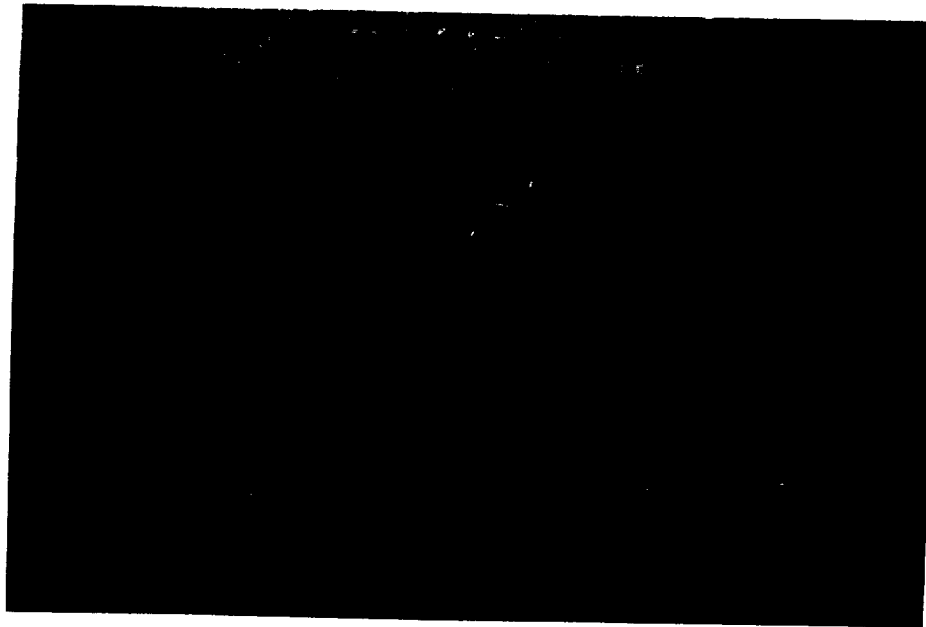

Figure 2.4.1(B) 35mm Handheld (Nikon F4) External Tank Photography (DTO-312)

Charring of the ET aft dome is visible (1). Also burn scars are apparent near the SRB attach points (2). ET aft dome charring and RSRB separation burn scars have been seen on previous missions and are not considered anomalous.

2.4.2 Analysis of the Umbilical Well Camera Films (Task #2)

Two rolls of STS-72 umbilical well camera film were acquired: the 16 mm film (5 mm lens), and the 16 mm film (10 mm lens) from the LH2 umbilical. The 35mm film from the LO2 umbilical did not run. The +X translation and the pitch maneuver were not performed on STS-72. The 16mm film views of the external tank were too dark for analysis.

As on previous missions, multiple pieces of debris was seen throughout SRB separation. Most of the debris was TPS insulation. No follow-up action was requested.

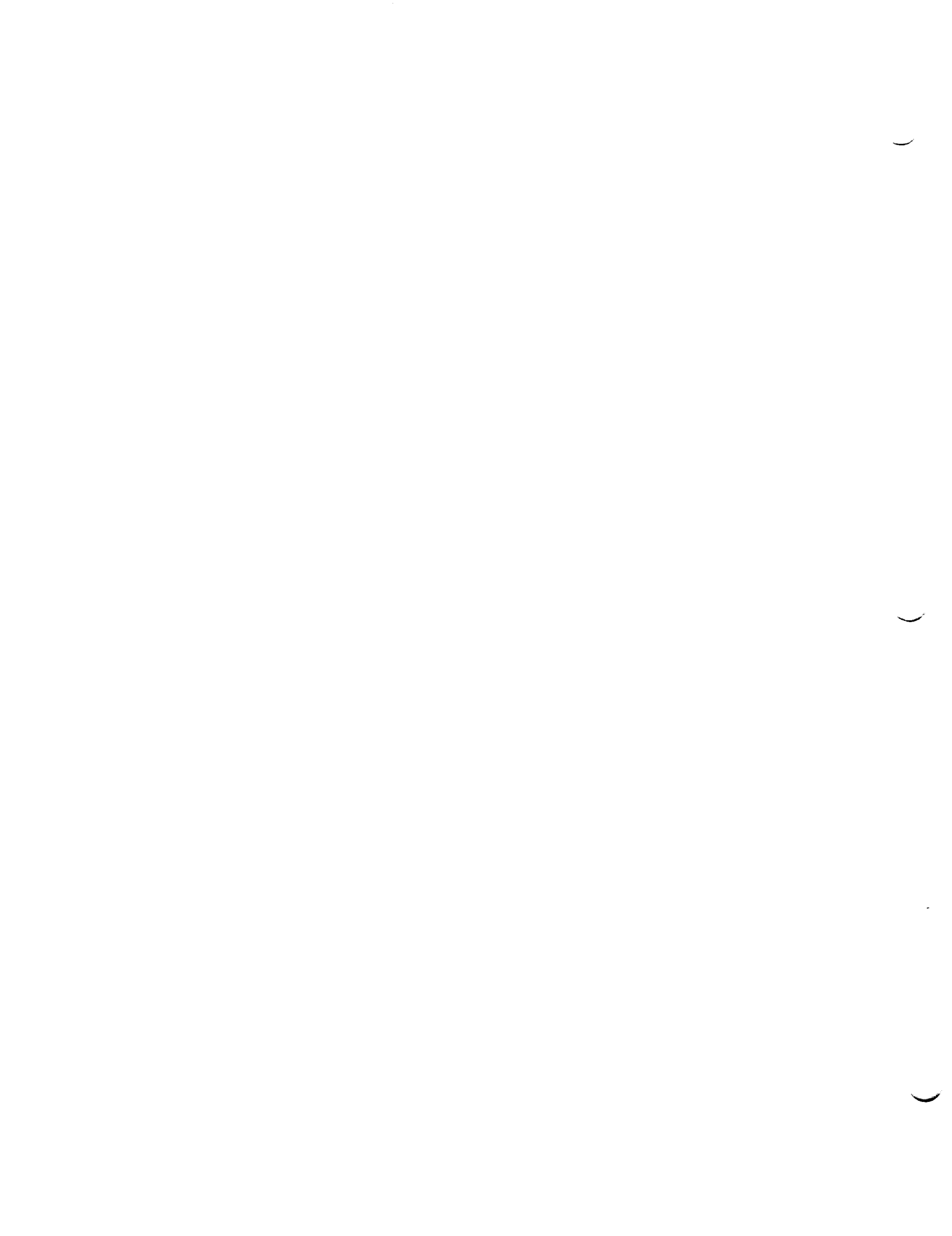

2. Summary of Significant Events

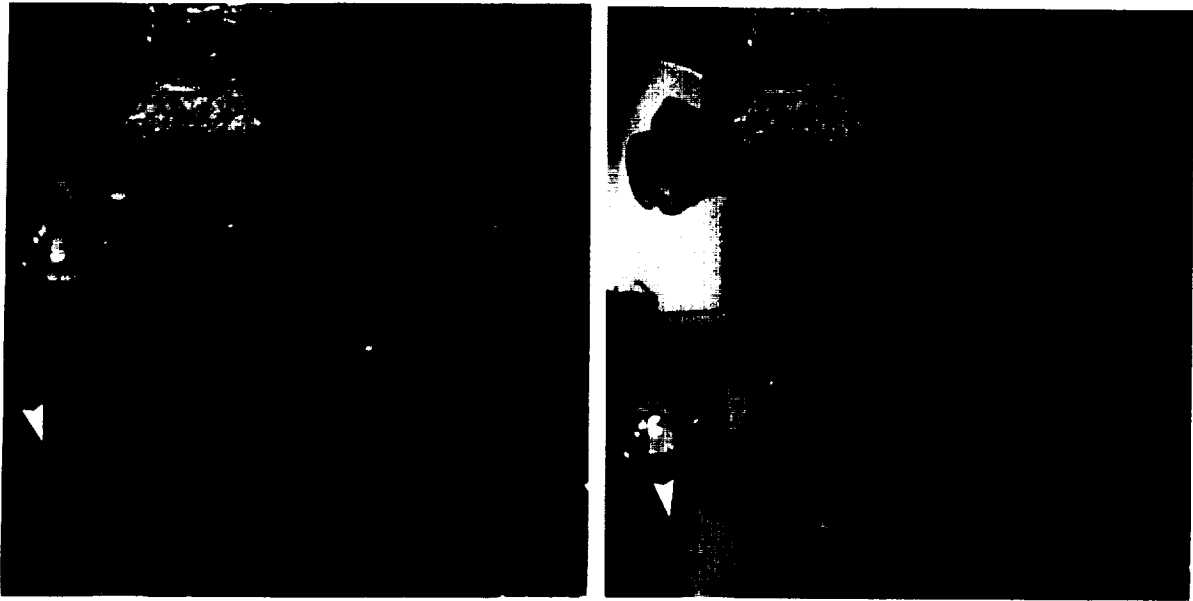

Figure 2.4.2 Debris Strikes LSRB (10mm lens view)

A dark colored piece of debris (probably insulation) was seen striking the LSRB a few inches aft of the ET attach ring shortly after SRB separation (1). The debris broke into multiple pieces at impact. A dark mark remained on the LSRB after impact (2). No damage to the RSRB due to the impact was seen on the SRB recovery photography. KSC did not report damage from the impact in the SRB post launch inspection report.

2.5 LANDING EVENTS

2.5.1 Landing Sink Rate Analysis (Task #3)

The main gear sink rate of the Orbiter was determined over a one second time period prior to main gear touchdown using landing film. Nose gear sink rate was not determined due to inadequate lighting conditions.

The measured main gear values were found to be below the maximum allowable values of 9.6 ft/sec for a 211,000 lb. vehicle and 6.0 ft/sec for a 240,000 lb. vehicle (the landing weight of the STS-72 Orbiter was reported to be 220,000 lb.). The sink rate measurements for STS-72 are given in Table 2.5.1. In Figure 2.5.1 the trend of the measured data points for film image data are illustrated.



2. Summary of Significant Events

<i>Prior to Touchdown (1 Second)</i>	<i>Sink Rate: Film</i>
<i>Main Gear</i>	<i>1.88 ft/sec</i>
<i>Nose Gear</i>	<i>N/A</i>

Table 2.5.1 Sink Rate Measurements

**STS-72 Main Gear Sink Rate From Film
(Camera EL-7)**

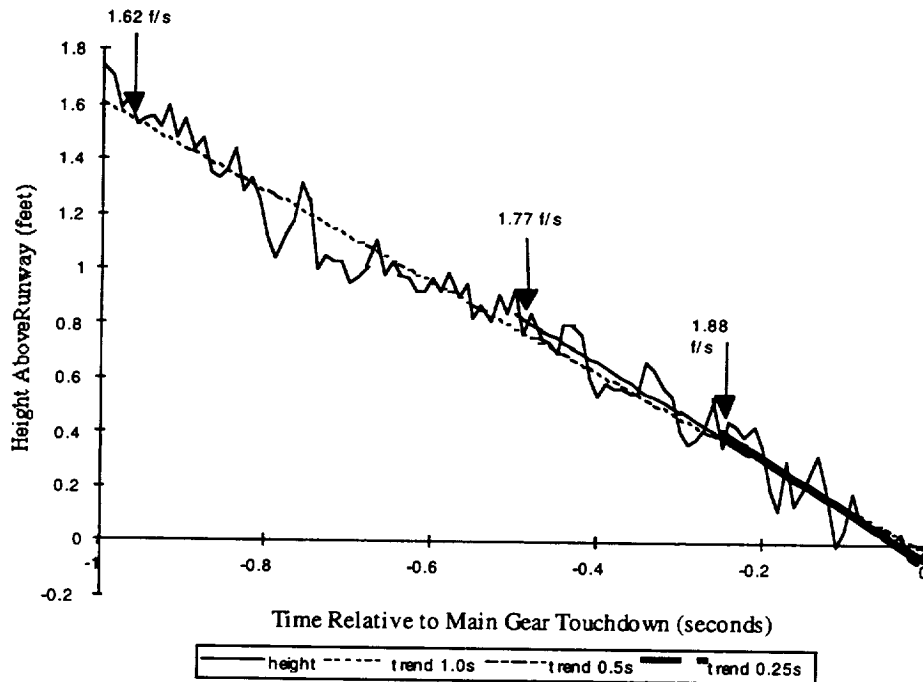

Figure 2.5.1 Main Gear Height Versus Time Prior to Touchdown (Film)

2. Summary of Significant Events

2.6 OTHER

2.6.1 Normal Events

Other normal events observed include: inboard elevon motion at SSME ignition, flares in SSME exhaust at SSME ignition, RCS paper debris at SSME ignition through liftoff, ET twang, acoustic waves at liftoff, pad debris during SSME ignition through liftoff, flame duct debris at liftoff, debris in the exhaust cloud after liftoff, vapor off the SRB stiffener rings after liftoff, outgassing of the ET aft dome, roll maneuver, forward RCS paper detaching after the roll maneuver, slight body flap motion after roll maneuver, expansion waves after the roll maneuver, SRB plume brightening prior to SRB separation, linear optical effects, SRB separation, multiple light colored debris in the SRB exhaust plume after separation.

Normal events seen that are related to the pad are hydrogen ignitor operation, fixed service structure (FSS) deluge water activation, GH2 vent arm retraction, sound suppression water initiation, mobile launch platform (MLP) water dump activation, LH2 and LO2 TSM T-0 umbilical disconnect, TSM door closure at liftoff.

APPENDIX B. MSFC PHOTOGRAPHIC ANALYSIS SUMMARY

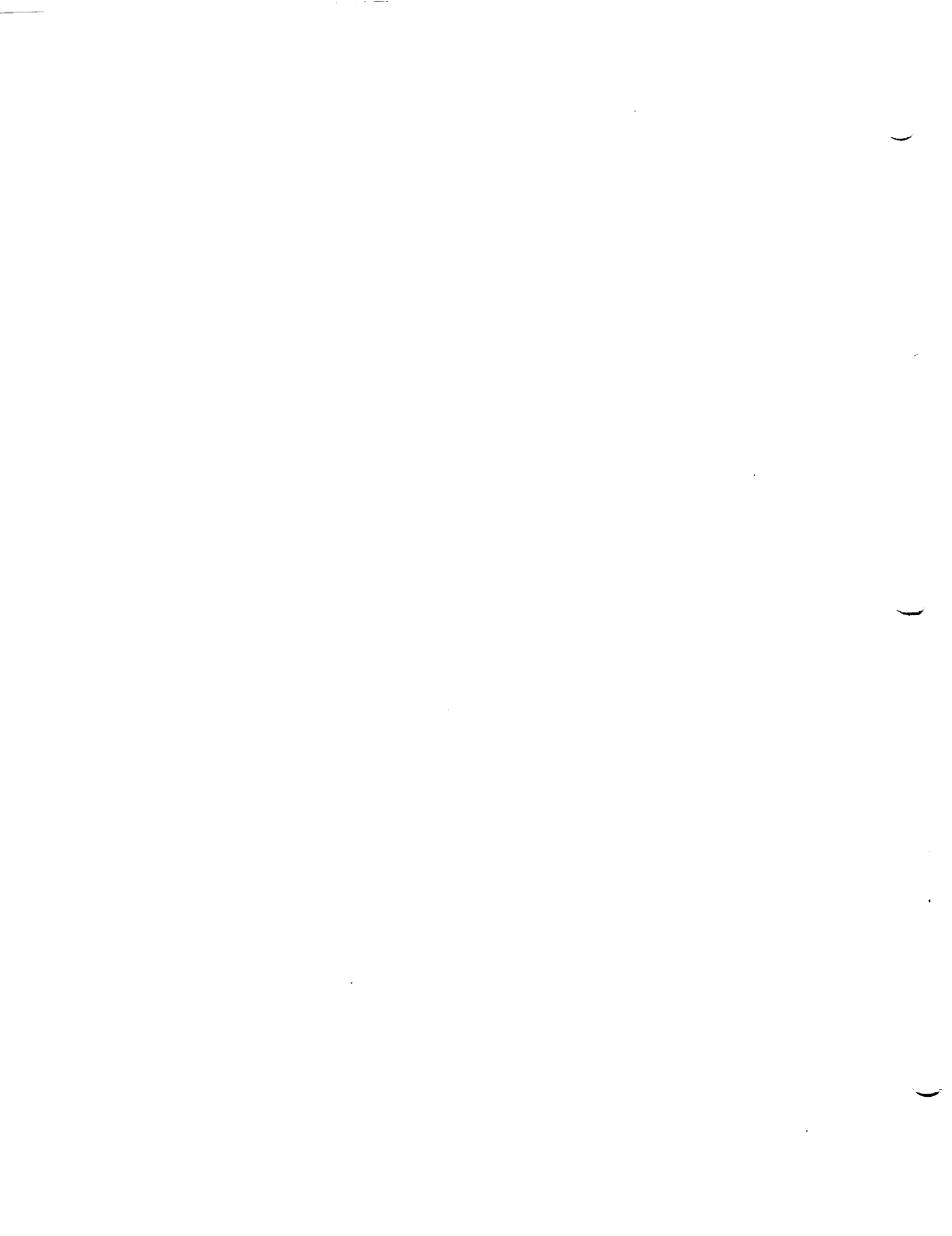

George C. Marshall Space Flight Center
Marshall Space Flight Center, Alabama 35812
AC(205)544-2121

Reply to Attn of:

EP42 (96-07)

February 9, 1996

TO: Distribution

FROM: EP42/Thomas J. Rieckhoff

SUBJECT: Engineering Photographic Analysis Report for STS-72

The launch of space shuttle mission STS-72, the tenth flight of the Orbiter Endeavour occurred on January 11, 1996, at approximately 4:41 A.M. Central Standard Time from Launch Complex 39B (LC-39B), Kennedy Space Center (KSC), Florida. Photographic and video coverage was evaluated to determine proper operation of the MSFC related flight hardware.

Film was received from fifty-one of fifty-four requested cameras as well as video from twenty-four requested cameras. The camera that views the ET tip and one of the long range tracking cameras experienced mechanical problems and provided no data. The dark sky condition from the early morning launch reduced the available data from all cameras.

The astronauts recorded eleven frames of the -Z, +Y quadrants of the ET after separation using the hand-held 35mm camera. The orbiter's two 16mm motion picture cameras in the LH2 umbilical well recorded the SRB separation event. The ET separation portion was unusable due to the dark sky conditions. The 35mm sequential still camera in the LO2 umbilical well malfunctioned.

No anomalies were observed. The typical events of ice/frost falling from the 17" disconnects at SSME ignition and liftoff, butcher paper falling from the vehicle and debris induced streaks were observed.

Several pieces of glowing debris particles were observed falling from the SRM plumes during ascent. Copious amounts of this type debris were noted at approximately T+18 seconds MET.

Frost was noted on the ET acreage at liftoff.

Frost was observed on the eyelid of ME-2 during liftoff. A single piece of debris appears to come from the upper surface of

the left elevon traveling in a +Z direction at liftoff. The origin of this debris is uncertain.

A piece of light colored debris appears to bounce off the RSRB aft skirt near the separation motors at T+25.4 seconds MET. No damage was observed. This debris piece may be associated with butcher paper from the Orbiter's forward RCS motor covers which was also observed falling aft during this time period.

The following event times were acquired.

<u>EVENT</u>	<u>TIME (UTC)</u>	<u>DATA SOURCE</u>
M-1 PIC Firing	09:41:00.024	Camera E-9
M-2 PIC Firing	09:41:00.024	Camera E-8
M-5 PIC Firing	09:41:00.023	Camera E-12
M-6 PIC Firing	09:41:00.025	Camera E-13
SRB separation	09:43:04.40	Camera E-212

This report and additional information are available on the World Wide Web at URL: <http://photo4.msfc.nasa.gov>. For further information concerning this report contact Tom Rieckhoff at 544-7677 or Jeff Hixson, Rockwell at 971-3082.

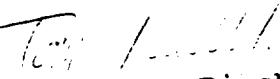
Thomas J. Rieckhoff

Enclosure

REPORT DOCUMENTATION PAGE

Form Approved
OMB No. 0704-0188

Public reporting burden for this collection of information is estimated to average 1 hour per response, including the time for reviewing instructions, searching existing data sources, gathering and maintaining the data needed, and completing and reviewing the collection of information. Send comments regarding this burden estimate or any other aspect of this collection of information, including suggestions for reducing this burden, to Washington Headquarters Services, Directorate for Information Operations and Reports, 1215 Jefferson Davis Highway, Suite 1204, Arlington, VA 22202-4302, and to the Office of Management and Budget, Paperwork Reduction Project (0704-0188), Washington, DC 20503.

1. AGENCY USE ONLY (Leave blank)	2. REPORT DATE February 1996	3. REPORT TYPE AND DATES COVERED Final 10-20 January 1996	
4. TITLE AND SUBTITLE Debris/Ice/TPS Assessment and Integrated Photographic Analysis of Shuttle Mission STS-72		5. FUNDING NUMBERS OMRS00UO	
6. AUTHOR(S) Gregory N. Katnik Barry C. Bowen Jill D. Lin		8. PERFORMING ORGANIZATION REPORT NUMBER TM-111469	
7. PERFORMING ORGANIZATION NAME(S) AND ADDRESS(ES) John F. Kennedy Space Center, NASA Vehicle Engineering/Mechanical Systems Division ET/SRB Branch TV-MSD-7 Kennedy Space Center, Florida 32899			
9. SPONSORING / MONITORING AGENCY NAME(S) AND ADDRESS(ES)		10. SPONSORING / MONITORING AGENCY REPORT NUMBER	
11. SUPPLEMENTARY NOTES			
12a. DISTRIBUTION / AVAILABILITY STATEMENT Blanket Release		12b. DISTRIBUTION CODE	
13. ABSTRACT (Maximum 200 words) A debris/ice/thermal protection system assessment and integrated photographic analysis was conducted for Shuttle mission STS-72. Debris inspections of the flight elements and launch pad were performed before and after launch. Icing conditions on the External Tank were assessed by the use of computer programs and infrared scanned data during cryogenic loading of the vehicle, followed by on-pad visual inspection. High speed photography of the launch was analyzed to identify ice/debris sources and evaluate potential vehicle damage and/or in-flight anomalies. This report documents the ice/debris/thermal protection system conditions and integrated photographic analysis of Shuttle mission STS-72 and the resulting effect on the Space Shuttle Program.			
14. SUBJECT TERMS SUBJECT CATEGORY: 15, 16 STS-72 Thermal Protection System (TPS) Ice Debris Photographic Analysis		15. NUMBER OF PAGES	
17. SECURITY CLASSIFICATION OF REPORT Unclassified		16. PRICE CODE	
18. SECURITY CLASSIFICATION OF THIS PAGE Unclassified	19. SECURITY CLASSIFICATION OF ABSTRACT Unclassified	20. LIMITATION OF ABSTRACT Unlimited	

**KSC DEBRIS/ICE/TPS ASSESSMENT AND INTEGRATED PHOTOGRAPHIC ANALYSIS
REPORT DISTRIBUTION LIST 9/95**

NASA - KSC

MK/L. J. Shriver
TE-COM-2/C. Brown
TV-PEO-2/R. Harrison
TV-MSD/C. Stevenson
TV-MSD-7/G. Katnik (7)
RO-SLQ-3/J. L. Shehane
GK-5/Z. H. Byrns

SK-LOS/J. Martin
LSO-321/H. L. Lamberth
LSO-437/M. Valdivia
ZK-88/K. J. Mayer
BICO-RVITS/R. B. Hoover
MMC-15/D. S. Otto
USBI-LSS/L. Clark

NASA - HQ

QSO/W. Comer

NASA - JSC

EP2/B. Rosenbaum
ES3/J. Kowal
FA22/D. Camp
SN3/E. Christiansen
SN5/M. Gaunce

Johnson Space Center
Houston, Texas 77058

NASA - MSFC

ED31/D. Andrews
EE31/M. A. Pessin
EE31/C. A. Snoddy
EP24/T. J. Rieckhoff

Marshall Space Flight Center
Huntsville, AL 35812

Rockwell - Downey

AE21/J. McClymonds
FA44/R. Ramon

Rockwell International
12214 Lakewood Blvd
Downey, CA 90241

Martin Marietta

Dept. 3571/S. Copsy
Dept. 4200/P. Lewis

13800 Old Gentilly Road
New Orleans, Louisiana 70129

P. O. Box 29304
New Orleans, Louisiana 70189