

EFFECT OF DIET ON METABOLISM OF LABORATORY RATS
The final and supplemental reports for the National Aeronautics and Space Administration

March 24, 1996

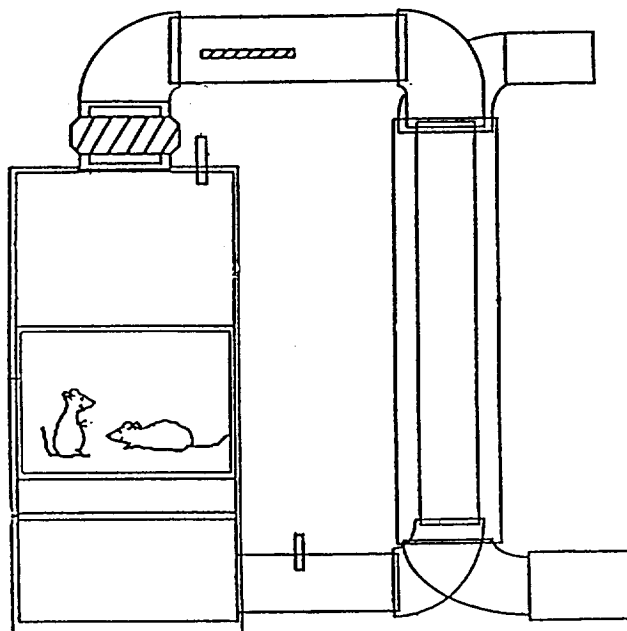

Investigators:

P.C. Harrison
G.L. Riskowski
J.S. McKee

Bioenvironmental Engineering Research Laboratory (BERL)
Animal Focus Group

University of Illinois at Urbana-Champaign
392 Animal Science Laboratory
1207 W. Gregory Drive
Urbana, IL 61801
(217)333-0069



TABLE OF CONTENTS

| | |
|---|-----|
| ABSTRACT | 1 |
| GENERAL PROCEDURE | 2 |
| MATERIALS AND MEASUREMENTS | 3 |
| Acclimation Chamber | 3 |
| Calorimeter Design | 4 |
| <u>Calorimeter Boxes</u> | 4 |
| <u>Air Temperature Control</u> | 4 |
| <u>Air Velocity Control</u> | 5 |
| <u>Air Humidity Control</u> | 5 |
| 1) Fresh air exchange | 6 |
| 2) Desiccant drying system | 7 |
| <u>Oxygen and Carbon Dioxide Analysis</u> | 7 |
| <u>Calibration of Calorimeters</u> | 8 |
| Environmental Variables Measured | 10 |
| Biological Variables Measured at Daily and Weekly Intervals | 12 |
| Biological Variables Measured at Thirty-day Intervals | 13 |
| RESULTS AND DISCUSSION | 15 |
| GENERAL SUMMARY | 23 |
| GENERAL CONCLUSION | 24 |
| REFERENCES | 24 |
| TABLES | 25 |
| FIGURES | 58 |
| A SUPPLEMENTAL REPORT | S-1 |



ABSTRACT

In previous studies when rats were fed a processed, semipurified, extruded rodent food bar (RFB) developed for Space Science research, we noted a difference in the appearance of gastrointestinal tissue (GI); therefore the following study evaluated GI characteristics and growth and metabolic rates of rats fed chow (C) or RFB. Two hundred and twenty-four rats (78 g mean body weight) were randomly assigned to 28 cages and provided C or RFB. Each cage was considered the experimental unit and a 95 percent level of significance, indicated by ANOVA, was used for inference. After each 30-, 60-, and 90-day period, eight cages were shifted from the C to RFB diet and housing density was reduced by two rats per cage. The two rats removed from each cage were sacrificed and used for GI evaluation. Metabolic rates of the rats in each cage were determined by indirect calorimetry. No differences in body weight were detected at 0, 30, 60 or 90 days between C and RFB. Heat production (kcal/hr/kg), CO₂ production (L/hr/kg) and O₂ consumption (L/hr/kg) were different by light:dark and age with no effect of diet. Respiratory quotient was different by age with no effect of light:dark or diet. Rats on the C diet ate less food and drank more water than those on RFB. C rats produced more fecal and waste materials than the RFB. GI lengths increased with age but were less in RFB than C. GI full and empty weights increased with age but weighed less in RFB than C. Gut-associated lymphoid tissue (GALT) numbers increased with age with no effect of diet. No differences in ileum-associated GALT area were detected between C and RFB. Switching C to RFB decreased GI length, GI full and empty weights, with no changes in GALT number or area. We concluded RFB decreased GI mass without affecting metabolic rate or general body growth.

GENERAL PROCEDURE

The effects of feed type and feeding period on energy exchange, moisture production, and contaminant production of rats were investigated over a 90-day experimental period. Feed treatments were ad libitum access to either a rodent food bar (RFB [a processed Teklad diet, TD93062]) or standard rat chow (C [an extruded pellet Purina diet, Certified Rodent Diet-5002]) diet (Table 1). Feeding periods were 30 days (0-30), 60 days (30-60) and 90 (60-90) days (Figure 1). Metabolic rate, moisture production, and contaminant production was measured in indirect calorimeters at the end of each feeding period; GI tissue from each feed type was also sampled following each feeding period. Average daily body weight, food consumption and water consumption were recorded and summarized weekly. Physical environmental parameters and contaminant production were recorded and summarized for the 90-day experimental period, each feeding period, and during calorimetry measurements. Data were analyzed using either single factor or repeated measure analysis of variance (ANOVA) and a level of 95% significance as indicated by Fisher's-Protected Least Squares Difference was used for inference purposes. The cage was considered the experimental unit for statistical evaluation.

To eliminate variability in response to different management conditions, male rats [Sprague Dawley (SD)] were purchased from a single distributor (Harlan Sprague Dawley, Inc., Indianapolis, IN) and started onto the experiment at a mean body weight of 78 ± 0.4 g and raised for the entire experimental period under uniform controlled conditions (acclimation chamber) in our laboratory. Therefore, all rats in this experiment were subjected to the same housing and management conditions.

Two hundred and twenty-four rats were randomly assigned to 28 cages (8 rats per cage). Eight cages started on RFB (B90), and 20 cages started on C diet (Certified Rodent Diet-5002, Purina Mills, Inc.) (Table 1). After the first 30-day feeding period, another six cages of rats were transferred from the C to the RFB diet (B60). The final group of six cages was transferred from the C to the RFB diet after the 30-60 feeding period (B30). Two rats were removed from each of the 28 cages after the 30, 60, and 90-day periods and used for GI tissue analysis. Two rats remained in each cage at the end of the experiment. The remaining rats continued their respective

diets and were used in a supplemental study that will be reported separately. The general treatment protocol is diagrammatically shown in Figure 1. All cages were placed in specially designed ventilation units that were used to house the animals in the acclimation chamber, during the entire experimental period. At the 30, 60, and 90-day calorimetry measurements, the rats were individually weighed and returned to their respective cage that was moved from the acclimation chamber into a randomly assigned calorimeter in a separately controlled environment room. The food and water that were assigned to each cage remained with that cage during the 24-hour calorimetry period. Photoperiod (12:12 L:D), temperature, air velocity, and humidity in the cage were essentially the same in the calorimeter as it had been in the ventilation unit.

MATERIALS AND MEASUREMENTS

ACCLIMATION CHAMBER

The acclimation chamber was a 3.2 m wide x 4.1 m long x 2.4 m high environmentally controlled, insulated chamber. Seven ventilation units were placed in the acclimation chamber to hold a total of 28 rat cages. Each rat cage had 6.4 mm thick plexiglass walls and was 305 mm wide x 432 mm long x 330 mm high. The floor and top of each cage were stainless-steel welded wire (2 meshes per 25 mm, 1.6 mm diameter) supported 203 mm apart (Figure 2). The specially designed ventilation units were used to develop a uniform distribution of air velocity (0.13 m/s) approaching the top of the rat cages. Rat wastes collected on a paper lining on the floor of the lower box which was replaced twice a week.

As shown in Figure 3, the ventilation units had an air settling means above the rat cages to uniformly distribute airflow approaching the cages. The air settling means consisted of three layers of perforated steel sheets with 50%, 40%, and 30% open area. An in-line duct fan was mounted on one side wall of the lower box. The fan created a slightly negative pressure inside the unit drawing air from the room into the unit. Air moved unidirectionally from top to bottom of the cage and was exhausted through the fan. Fan motor speed was controlled with a motor speed regulator to control the magnitude of the air velocity approaching the rat cage. The ventilation rate and air velocity were also controlled using a bypass valve located on the side opposite the fan.

CALORIMETER DESIGN

Three indirect, convective calorimeters were developed for this project (Figure 4). Air temperature, velocity, and relative humidity were controlled in each calorimeter. Desired air temperature was 22 C, air velocity was 0.13 m/s, and relative humidity was 55%. Fresh air exchange rate (FR) was also precisely controlled at around 2 l/m during the 30-day calorimetry and 8 l/m during the next two calorimetry runs. Air entering and leaving the calorimeters was pumped to the O₂ and CO₂ analyzers for determining animal metabolic rate.

Calorimeter Boxes: The calorimeter boxes were constructed from 6.4 mm thick plexiglass and were 356 mm wide x 1070 mm high x 585 mm deep. Clear plexiglass was used to allow observation of animals and to allow light into the calorimeter from the environmental chamber. Ledges were placed 445 mm above the box floor; upon which the bottom of the rat cages was supported. Another ledge was placed 180 mm below the bottom of the rat cage to support a stainless steel wire rack (15 mm x 15 mm wire spacings) which held a filter below the cages. The filter was a polyester air filter media and served to catch feces.

The entire front panel was removable to allow access of workers and to move rats in and out. The inside edges of the front panel were coated with vacuum grease to form a seal and were clamped on the calorimeter with ten clamps around the perimeter. A recirculation pipe, 200-mm diameter plexiglass tube, exited from the bottom of the calorimeter box, went up and over the calorimeter, and attached to an in-line fan on top of the calorimeter box. This air recirculation system allowed for the control of air velocity past the animals without affecting the fresh airflow exchange rate.

Air Temperature Control: The calorimeter box and air recirculation system were completely sealed to maintain the gas balances. Therefore, heat generated within the calorimeter had to transfer through the box or tube surfaces. To enhance this heat transfer process, all three calorimeters were placed within an environmental chamber that was operated at a lower temperature than the calorimeter air temperature. Also, a plastic duct which served as a heat exchanger, was placed around the vertical portion of the air recirculation tube and conditioned air was forced between that duct and the vertical portion of the air recirculation tube to create a heat exchange system. One separate air conditioning/heating unit per calorimeter was placed outside

the environmental chamber. Air from the tube heat exchanger surface was recirculated through these units to control the temperature of the air passing through the heat exchanger and, thus, the amount of heat leaving or entering the heat exchanger. This heat exchange system, plus a 150W electric heater bar placed in the top of the air recirculation tube, allowed for precise control of air temperature entering the top of the calorimeter boxes.

The heat exchanger, air conditioners, and heaters were controlled with a microprocessor PID temperature controller (Omega, Model CN9122A). Each calorimeter was individually controlled. Temperatures within the calorimeters were sensed with one Type T thermocouple placed in the center of the calorimeter box just above the rat cage.

Air Velocity Control: Air moved downward through the calorimeter so the movement was from top to bottom in the animal cages. Air movement was created by recirculating air through the air recirculation tube described previously (Figure 4). An in-line fan was placed on top of the calorimeter and forced air down through the calorimeter box and around through the recirculation system. There was a square air diffuser at the air entry at the top of the calorimeter that distributed the air over the calorimeter cross-section. To further improve the uniformity of airflow across the cross-section, an air settling means was placed below the diffuser and above the animal cage. The air settling means consisted of three perforated stainless steel sheets with 60%, 40%, and 30% openings. To ensure that there was a uniform profile of air velocities approaching the top of the animal cages, a 3 x 5 grid of air velocity measurements was taken between the air settling means and above the top of the cages before each test. If air velocities from point-to-point varied by more than 20%, the diffuser vanes were adjusted to obtain a more uniform profile.

The airflow rate through the recirculation fan was controlled by an 80-mm diameter orifice in the tube above the fan and by adjusting the fan speed with a voltage controller. Airflows were adjusted with the fan speed controller until the average of the air velocities taken in the 3 x 5 grid was within 10% of the desired value.

Air Humidity Control: Relative humidity of the air within the calorimeters was controlled by two methods: 1) fresh air exchange and 2) desiccant drying system:

- 1) Fresh air exchange - The fresh air that entered the calorimeter, due to the air exchange system was drier than the calorimeter air so there was a net reduction of moisture. Most of the fresh air entered the calorimeter through a desiccant drying system (anhydrous calcium sulfate, #8 mesh granules) which effectively removed all of the moisture from that air. The remainder of the fresh air entered through leaks and that air was at the same conditions as the environmental chamber.

Fresh air exchange (ventilation) was provided to each calorimeter for several reasons: 1) maintain appropriate O₂ and CO₂ levels, 2) remove moisture and help maintain appropriate relative humidity, and 3) provide sample of air for metabolic rate analysis. Air was removed from the lower part of the 200-mm diameter air recirculation tube and passed through a Gilmont Instruments Model GF1300 air flow meter (accuracy = $\pm 2\%$ of reading or ± 1 scale division). All tubing used was 6-mm diameter polypropylene. The air then flowed to a diaphragm pump that had a 500-ml beaker in line to dampen the oscillations from the pump. Airflow rate was controlled by an air bypass system with a needle valve. Air flowed from the pump system to the gas analysis instruments, electronic controls, and computer data acquisition system, which were all located in an adjacent environmental chamber.

Air drawn out of the calorimeters was precisely measured and used as flow rate (FR) in the O₂ consumption and CO₂ production calculations. A slight negative pressure was maintained (approximately 12 Pa) within the calorimeters. This negative pressure would draw in the same amount of fresh air from the surrounding environmental chamber as was removed by the pump. A planned air inlet (8-mm diameter hole) was placed in the lower part of the air recirculation tube, but some fresh air would have entered through unplanned inlets (leaks). Since the entire calorimeter was at a negative static pressure and a certain amount of air had to enter the calorimeter anyway, the leaks did not create a problem.

The air that entered the planned inlet passed first through a container of desiccant to remove its moisture. A 100-mm diameter x 360-mm high plexiglass container with open top was filled with approximately 2900 g of desiccant. Fresh air from the environmental chamber flowed downward through the desiccant into an 8-mm diameter polyethylene tube at the bottom and into the calorimeter.

2) Desiccant drying system - A separate air humidity control system was developed to remove moisture from the calorimeter air. To accomplish this, calorimeter air was recirculated through a desiccant drying system. Each calorimeter had two air drying systems. Calorimeter air was pumped from the area below the animal cages (airflow rate approximately 10 l/m) through 8-mm diameter polyethylene tubing to a 100-mm diameter x 360-mm high sealed plexiglas container filled with desiccant. As the air passed through the desiccant, it effectively removed all of the moisture. The relative humidity exiting the bottom of the drying container was measured to be 0% with a Tri-Sense temperature/humidity meter (Model 37000-00). Each container held approximately 3800 g of desiccant. The air then passed through tubing to a diaphragm air pump and finally back into the lower part of the calorimeter box. The air pumps turned on when the calorimeter relative humidity exceeded 55% and stopped when the relative humidity was reduced back to 55%. The relative humidity in the calorimeters was sensed electronically with a General Eastern (Model RH-5-V) humidity transducer. This signal was collected on a Keithley Metrabyte DAS-8/PGA data acquisition system connected to an IBM compatible PC. The signals were analyzed with Keithley Metrabyte VIEWDAC software that controlled an electronic relay that controlled power to the drying system pumps. After each calorimetry test, the desiccant was dried in an oven at 220 C for 1.5 h and reused.

Oxygen and Carbon Dioxide Analysis: Air flowed through a computer-controlled solenoid valve switching system that controlled air flow to the O₂ and CO₂ analysis instruments (Beckman Model OM-11 and LB-2, respectively). Air was analyzed from six sources--the three calorimeters, the environmental chamber that housed the calorimeters, and two standard gases. Each source was connected to a separate solenoid valve that directed air through the O₂ and CO₂ analyzers and either stopped air flow (standard gases) or redirected it into the outside room (calorimeter and chamber air). All of the solenoid valves were controlled by an automatic switching system that directed which source of gas would be analyzed. The switching system cycled through all six sources every 30 minutes. The switching sequence was: each calorimeter for 6 minutes (O₂ and CO₂ out), environmental chamber for 6 minutes (O₂ and CO₂ in), and each standard gas for 3 minutes. Certified standard gases (Matheson) were used to set the range of O₂ and CO₂ that was to be analyzed. Standard gas #1 was calibrated to have around 19% O

concentration and 1% CO₂ concentration. Standard gas #2 was calibrated to have 17% O₂ concentration and 0.5% CO₂ concentration. Output from the gas analyzers was continuously recorded on a strip chart recorder and by the computer data acquisition system.

Calibration of Calorimeters Accuracy of O₂ consumption and CO₂ production was determined from burning ethanol in the calorimeters. This procedure also served as an integrated check on all components of the calorimeter and determined the overall accuracy of the calorimeter.

An ethanol lamp was filled with absolute ethanol (EtOH) and placed on an analytical balance that had been leveled in the floor of a rat cage placed inside a calorimeter. The lamp was ignited, the calorimeter door was sealed shut, FR was set and the gas analysis switching sequence was initiated. After the ethanol lamp established a steady burn rate, the change in weight (g/min) of the ethanol lamp was measured with a stop watch over several 1, 5, and 10-min periods (ΔEtOH). Differences in percent O₂ content of air leaving the calorimeter (O_{2out}) was subtracted from O₂ content of air entering the calorimeter (O_{2in}) over 5-min periods at 30-min intervals ($O_{2in} - O_{2out} = \Delta O_2$). The same procedure for CO₂ analysis was simultaneously recorded ($CO_{2out} - CO_{2in} = \Delta CO_2$). Accuracy, recovery, and calibration values for each calorimeter were obtained by comparison of respiratory quotient [$RQ = (\text{CO}_2 \text{ produced})/(\text{O}_2 \text{ consumed})^{-1}$] and recovery of gases obtained from the ΔEtOH , $\Delta O_2\%$, and $\Delta CO_2\%$ measurements. Calibration of each calorimeter was conducted before and after each of the 30, 60, and 90-day animal calorimetry periods. Calibrations had RQ ranges from .65 to .71 and accuracy of O₂ recovery ranged from 97% to 106%.

Sample Calibration for a Calorimeter
(6-29-94, Calorimeter 3)

Assumptions: EtOH has a molecular weight of 46.0694, 22.414 liters (L) of gas per mole, and 4.9 Kcalories of energy per L O₂ consumed, and 7.1 Kcal/g of heat of combustion.

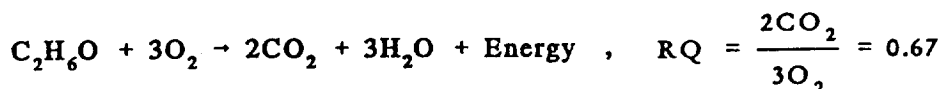

Data from Analytical Balance:

$$\Delta\text{EtOH} = 0.11 \pm 0.009 \text{ g/min}$$

$$\begin{aligned} \text{L O}_2/\text{min for } \Delta\text{EtOH} &= (0.11 \text{ g/min})(46.0694 \text{ g})^{-1}(22.414 \text{ L/mole})(3 \text{ mole O}_2)(.922_{\text{STP}}) \\ &= 0.148 \text{ L O}_2/\text{min} \end{aligned}$$

Data from Gas Analysis:

$$\Delta\text{O}_2\% = (\text{O}_{2\text{in}} - \text{O}_{2\text{out}}) = 1.879\%$$

$$\Delta\text{CO}_2\% = (\text{CO}_{2\text{out}} - \text{CO}_{2\text{in}}) = 1.288\%$$

$$\text{RQ} = \frac{1.288}{1.879} = 0.69$$

$$\begin{aligned} \text{L O}_2/\text{min for } \Delta\text{O}_2\% &= (.01879 \text{ O}_2)(8.4 \text{ L/min FR})(0.922_{\text{STP}}) \\ &= 0.146 \text{ L O}_2/\text{min} \end{aligned}$$

$$\text{Recovery \%} = \frac{\text{L O}_2/\text{min for } \Delta\text{O}_2\%}{\text{L O}_2/\text{min for } \Delta\text{EtOH}} \times 100 = \frac{0.146}{0.148} \times 100 = 98.6$$

ENVIRONMENTAL VARIABLES MEASURED

In the acclimation chamber, the following environmental variables were monitored:

- Air temperature of the room air. Measurements were taken every 15 minutes above each cage.
- Air humidity and temperatures were taken at one location in the chamber with a hygromograph. Chart readings were continuous and values were recorded on an hourly basis.
- Air velocities approaching the top of the rat cages were taken once a week with an omnidirectional anemometer over the center of each cage.
- Ammonia levels in each cage were taken once a week with a gas detector meter.
- Dust levels in the chamber were taken once a week with two methods—particulate weight per volume of air and particle counts.
- Noise levels in the cages were recorded before the overall experiment began.

In the calorimeters, the following environmental variables were measured:

- Air temperatures above the center of rat cages were taken every 10 minutes.
- Relative humidity of air just above the center of rat cages was taken every 10 minutes.
- Air velocity at 15 locations above the rat cages was recorded before each 24 h calorimetry run.
- Dust levels of air after it passed through the rat cages were measured as particulate counts and taken with a laser counter every 4 h during each 24 h calorimetry run.
- Ammonia levels of the air after it passed through the rat cages were taken with a gas detector meter every 4 h during the calorimetry runs.
- Light levels at the bottom, center of each rat cage location were taken with a light meter before and after each set of calorimetry runs.
- Noise levels at the bottom, center of each rat cage were taken with a sound meter before and after each set of calorimetry runs.
- Fresh Air Exchange (FR), that was used to calculate O₂ consumption and CO₂ production, was taken visually and recorded every 4 h.

In the environmental chamber that housed the calorimeters, the following environmental variables were measured:

- Air temperature near each of the three calorimeters was taken every 10 minutes.
- Air humidity and temperature was taken continuously with a hygromograph at one location in the chamber.
- Dust levels were taken every 4 h during the calorimetry runs with a laser particle counter.

- Ammonia levels were taken every 4 h during the calorimetry runs with a gas detector meter.

Unless stated otherwise, all temperatures were measured with type T (copper-constantan) thermocouples connected to a data logger (Model 21X, Campbell Scientific, Inc.) which was interfaced to an IBM compatible PC. The calibration of the thermocouples with long leads was checked by placing them in a water bath at two temperatures (18 C and 28 C). The water bath temperature was checked with a calibrated thermometer. The humidity sensors in the calorimeters were General Eastern RH-5-V with an accuracy of $\pm 5\%$. The chamber air humidity and temperatures were recorded continuously with temperature/humidity recorders (Model CT480RS, White Box and Model 594, The Bendix Corp.). Humidity sensors were calibrated in the expected operating range with a mechanically aspirated psychrometer.

Air velocity was measured with an omnidirectional probe (Model 8470, TSI, Inc.), which was accurate to within $\pm 6.5\%$ of velocity reading. The air velocity probe was calibrated before each set of calorimetry runs with a wind tunnel (Model 1125, TSI, Inc.) which was calibrated to NIST traceable standards. The probe was connected to a power supply/display unit. Light intensity levels were measured in lux with a light meter (Model P401025, Extech Instruments), with an accuracy of $\pm 5\%$ of light reading. Noise levels were measured with a sound level meter (Model 1400, Quest Electronics), which had a ± 1 dBA accuracy. Ammonia levels were measured with a PhD ammonia gas detector meter (Model 1600W/1633, Biosystems, Inc.), which had an accuracy of $\pm 5\%$ of the reading. The ammonia meter was calibrated against a standard gas that had 50 ppm NH_3 and the balance was nitrogen.

Dust particle counts in the calorimeters were taken with a laser based airborne particle counter (Model CI-7350, Climet Instruments Co.) which was recently calibrated to NIST traceable standards. This counter determined the number of particles per volume of air for the following particle diameters: $> 10 \mu\text{m}$, $> 5 \mu\text{m}$, $> 1 \mu\text{m}$, $> 0.7 \mu\text{m}$, $> 0.5 \mu\text{m}$, and $> 0.3 \mu\text{m}$. The ranges include all of the particles counted that were larger than the diameter stated. So, the smaller range values would also include the particles counted in the larger range values, e.g., the counts for the $> 0.3 \mu\text{m}$ range also include the particles given in the ranges above it. Approximately 30 lpm of air was collected from the calorimeters and chambers for the dust counter samples. In order to clear the tubes, air was pumped from the sampling port for one minute before counting began, then counts were taken for a two-minute period. Three counts were taken and averaged for each reading. After the air was analyzed for dust levels, it was pumped back into the calorimeter so it would have little effect on air exchange rates of the calorimeters. Air was drawn into the sampling tubes through specially sized nozzles to ensure that isokenitic conditions existed. Note that the

filters under the rat cages would remove some dust since all of the air moving through the calorimeters passed through the filters. The filter material was a polyester air filter media.

Dust weight per volume of air measurements were determined in the acclimation chamber, where the rats were housed over the entire experimental period by pumping a known volume of air through a 0.1 μm pore filter and weighing the filter before and after. Dust weight samples were not collected in the calorimeters due to the large volumes of air needed to obtain an accurate reading. Large air exchange rates would affect the other readings taken in the calorimeter and would not give accurate dust readings in such a small sampling volume.

BIOLOGICAL VARIABLES MEASURED AT DAILY AND WEEKLY INTERVALS

In the acclimation chamber, the following animal indices were monitored:

- Rat body weight: All rats were removed from their cage and individually weighed with a top loading Sartorius (L610) balance, weekly.
- Food consumption: Premeasured food (RFB and C) was provided ad libitum, checked daily, and additional food was weighed into each cage if the initial supply was getting low. Chow diets were in cube form and placed in standard stainless steel rat feeders. The RFB diet was wired to stainless steel mesh that was fixed to one wall of the cage. Feed weighed back was to be subtracted from additions weekly; however, because of initial over and under estimations of anticipated food requirements, food additions and weigh backs were not always taken at the same exact weekly intervals. Consequently, some weekly food consumptions were not taken on the same reference day. Although the consumption data are accurate, when expressed weekly, they may represent a slightly higher or lower value on alternate weeks. This food weigh back interval problem was corrected during the last half of the experimental period.
- Water Consumption: Premeasured water volumes were supplied via lixit watering devices connected to water bottles. Water was added and recorded on a daily basis. Ending water volumes were subtracted from premeasured water volumes, and consumption was calculated weekly.
- Fecal and Waste Production: Once a week the paper lining from the floor of ventilation units that housed either RFB or C diet cages was removed, and weight and volume of waste was measured. Waste material was weighed on a Sartorius (Model E12000S) top loading balance. Volume was determined by water displacement.

BIOLOGICAL VARIABLES MEASURED AT THIRTY-DAY INTERVALS

Calorimetry: Indirect calorimetry measurements were obtained at thirty minute intervals over a 24-h period 30, 60, and 90 days from the initiation of the experiment. During the calorimetry period, the number of rats per cage and diet treatment assigned to the cage during the previous 30-day period remained the same. Calorimetry was conducted for six cages of rats from each diet treatment at the end of their respective preceding feeding period. The calorimetry sequence was: (1) At the first calorimetry period (30 days), six cages of the C treatment and six cages of the B90 treatment were measured over a continuous four-day interval; (2) At the second calorimetry period (60 days), six cages each from the C, B90 and B60 treatments were measured over six days and; (3) At the third calorimetry period (90 days), six cages from each of the C, B90, B60 and B30 treatments were measured over an eight-day interval. Cages were systematically assigned to calorimetry day and calorimeter so that cages from the same diet treatment were not evaluated on the same day and not always in the same calorimeter. Cages in a dietary treatment were randomly assigned on the starting day of calorimetry. Calorimetry values expressed on a per unit of body weight basis were oxygen consumption, carbon dioxide production, and heat production. Calculations were the same as for the ethanol lamp. Heat production was calculated based on RQ and oxygen consumption that was written into a computer program. The computer program calculated heat production (Kcal/min/Kg) based on a linear relationship between $RQ=0.7$ with a caloric equivalent of 4.686 Kcal/ LO_2 and $RQ=1.0$ with a caloric equivalent of 5.047 Kcal/ LO_2 .

Moisture Production: Water from calorimetry was also measured; however, metabolic water could not be separated from water evaporation caused by drinking, water spills, and body fluids voided into the calorimeter. Metabolic water can be estimated based on the assumption that with a balanced diet, nutrient sources for energy are from protein, carbohydrate, and fats. The range of water produced per Kilocalorie of energy liberated in metabolism of mixed nutrients is 0.09 to 0.13 g H_2O /Kcal. An average value of 0.11 g H_2O /Kcal was used to calculate the estimated metabolic water production that occurred during calorimetry.

Moisture was removed from the calorimeters through the ventilation air and through a desiccant air drying system. During the first calorimetry period (5/2/94 - 5/5/94), air was removed from the calorimeters at a rate of around 2 liters per minute (lpm). During the second and third calorimetry periods (5/31/94 - 6/5/94 and 6/30/94 - 7/7/94), air was removed from the calorimeters at a rate of around 8 lpm. Fresh air from the environmental chamber entered the calorimeter through a small hole at the lower part

of the recirculation duct and through leaks. During the first period, all of the air entering the calorimeters was at the same conditions as the chamber air. During the second and third periods, some air passed through a column of desiccant to dry before entering the calorimeters. The desiccant was dried in an oven for 1.5 h at 220 C before use and was weighed before and after use. The amount of weight change was the amount of moisture absorbed out of the air. The desiccant was anhydrous calcium sulfate, #8 mesh granules. The moisture removed from the calorimeters by ventilation was calculated by:

$$Mv = ((Wc-Wi)/Vs) \times (453.6 \text{ g/h} / 28.32 \text{ l/ft}^3) \times FR \times 60 \text{ min/h}$$

- where: Mv = moisture removed from calorimeter by ventilation, g/h
 Wc = moisture level of air exiting calorimeter, lb water/lb dry air
 Wi = moisture level of air entering calorimeter, lb water/lb dry air
 Vs = specific volume of air exiting calorimeter, ft³/lb dry air
 FR = air exchange flow rate, lpm

The moisture level of air entering the calorimeter, Wi , was calculated by:

$$Wi = Wr \times ((Wmax - DM) / Wmax)$$

- where: Wr = moisture of air in the chamber housing the calorimeters, lb water/lb dry air
 $Wmax$ = maximum amount of moisture that could have entered the calorimeter if the desiccant system was not removing moisture, lb
 DM = measured moisture removed by the desiccant system, lb

The relative humidity control system discussed earlier was used to remove excess moisture from the calorimeter air to maintain the calorimeter relative humidity at around 55%. During the first two sets of calorimetry runs, there was one pump and desiccant column per calorimeter. During the last set of calorimetry runs, there were two per calorimeter. The pumps were controlled by a computer with a feedback loop from the relative humidity sensor so they would turn on only when the relative humidity rose above the desired level. The desiccant was weighed in and out for each calorimeter to determine the amount of moisture removed during each calorimeter test. The moisture collected by the relative humidity control system was added to the calculated amount of moisture removed by the ventilation system to get the total moisture production in the calorimeters.

Gastrointestinal (GI) Evaluation: Following each calorimetry period (30, 60, and 90 days) two rats from each of the 28 cages were removed from their home cage and euthanized in a separate precharged CO₂ chamber (Figure 1). The rats were individually marked for identification purposes before euthanasia. Following euthanasia the rats were weighed, the gastrointestinal tract was removed from the pharyngeal

end of the esophagus to the colorectal area and weighed with full contents. After obtaining the full GI weight, the GI tract was flushed with a cold physiological saline solution, followed by a flush with a 10% buffered formalin solution. The tract was then extended beside a ruler that was taped to a laboratory bench for determination of GI length. While extended on the laboratory bench the number of nodules (Peyer's Patches or gut associated lymphatic tissue [GALT]) were macroscopically counted. The tissue was weighed again (empty weight), and tissue samples containing GALT and adjacent areas were taken from the duodenum, ileum, and jejunum and preserved in a 10% buffered formalin solution. To reduce autolysis, all these processes were accomplished within two to five minutes following euthanasia.

The formalin fixed tissue was histologically processed and stained with a standard hematoxylin-eosin dye. The tissues were then blind examined and evaluated by Dr. J. Johnson, a veterinary histopathologist. All of the histological processing and evaluation were conducted at the Veterinary Histopathology Laboratory of the University of Illinois. Following evaluation the results, tissues, and slides were returned to our laboratory and histologically examined by the scientist that had evaluated the GI tissue for our previous report, "Design and Evaluation of Spatially Enhanced Caging for Laboratory Rats at High Density." Histologically the size or area of the GALT was determined as width (mm) x height (mm). The tissue around and adjacent to the GALT was also scored. Scoring was by an arbitrary value assigned to the histological description. The scoring was: 0=essentially normal, 1=mild lymphocytic infiltration of intestinal villi, and 2=heavy lymphocytic infiltration of intestinal villi.

RESULTS AND DISCUSSION

ENVIRONMENTAL VARIABLES

Air Temperature: The average air temperatures in the acclimation chamber are presented in Table 2. The temperatures are separated for each period before the three calorimetry periods. In the acclimation chamber the air temperatures were consistently around 22 C.

The average air temperatures above the rat cages in the calorimeters are presented in Table 3. The temperatures are separated by food treatment for each of the three calorimetry periods. The calorimeter air temperatures were around 21-22 C and there was little difference across the treatments.

The average air temperatures in the chamber housing the calorimeters were around 16-18 C (Table 3). The chamber air temperatures were kept lower than the calorimeter temperatures to enhance heat transfer out of the calorimeters.

Air Relative Humidity: The average relative humidities in the acclimation chamber are presented in Table 2. They are separated for each period before the three calorimetry periods. The air relative humidity was around 57% before the first calorimetry period and 53% before the second and third calorimetry periods.

The average relative humidities above the rat cages in the calorimeters are presented in Table 3. They are separated by food treatment for each of the three calorimetry tests. The calorimeter air relative humidity was around 60% the first period, 65% the second period, and 55% the third period. There was no difference across treatments.

The average air relative humidities in the chamber housing the calorimeters are presented in Table 3. The average chamber air relative humidity was around 63-64%.

Air Velocity: The average air velocities approaching the top of the rat cages in the acclimation chamber are presented in Table 2. They are separated by food treatment for each period before the three calorimetry runs. The air velocities were around 0.13 m/s before the first calorimetry period, 0.14 m/s for the second period, and 0.12-0.15 m/s before the third calorimetry period. There was no difference across treatments.

The average air velocities above the rat cages in the calorimeters are presented in Table 3. They are separated by food treatment for each of the three calorimetry tests. The calorimeter air velocities were around 0.13 m/s the first period, 0.14 m/s the second period, and 0.13 m/s the third period. There was no difference across the treatments.

Ammonia Level: The average air ammonia levels above the rat cages in the acclimation chamber are presented in Table 2. They are separated by food treatment for each period before the three calorimetry tests. The ammonia levels were around 3.4 ppm before the first calorimetry period, 1.5 ppm for the second period, and 0 ppm before the third calorimetry period. There was no difference across treatments.

The average ammonia levels in the calorimeters are presented in Table 3. They are separated by food treatment for each of the three calorimetry periods. The calorimeter ammonia levels were around 0.4 ppm the first period, 3.5 ppm the second period, and 0.7 ppm the third period. There was no difference across the treatments.

The average ammonia levels in the chamber housing the calorimeters are presented in Table 3. The chamber ammonia level ranged from 1.5 to 3.9 ppm.

Dust Level: The dust weight per volume of air sampled weekly in the acclimation chamber is presented in Table 4. The average value for 9 weeks of samples was 0.091 mg dust per m³ of air. Since

the dust weight data was collected in the acclimation chambers where the rats were housed, it would be reasonable to assume that the dust density would be similar in other rat housing applications. The particle counts for the dust samples taken in the acclimation chamber is presented in Table 5. The particle counts for one micron and smaller particle sizes tended to increase with time. Possibly due to the larger rat mass with time or a build-up of dust in the chamber with time.

The particle counts for the air samples from the calorimeters for each sampling period are in Tables 6-8. The approximate times for each sampling period were: Period 1 - 10:30 am, Period 2 - 1:30 pm, Period 3 - 5:30 pm, Period 4 - 9:30 pm, Period 5 - 1:30 am, and Period 6 - 5:30 am. Table 9 gives the average particle count over all six time periods, and Table 10 gives the average particle counts for the light time periods (1-3) and the dark time periods (4-6). The chamber housing the calorimeters generally had higher particle counts than the calorimeters; therefore, incoming ventilation air would tend to raise rather than lower dust levels in the calorimeters. The filters under the rats may have reduced the dust levels in the calorimeters. Since the standard deviation is inherently large for dust and particle samples, there were no significant differences in particle counts in the calorimeters across treatments. The particle counts were generally higher for the dark periods for the first two calorimetry runs but had the opposite trend for the third calorimetry run.

Noise Level: The average noise level above the rat cages in the acclimation chamber are presented in Table 2. They are separated by food treatment for each period before the three calorimetry periods. The noise levels were around 75 dBA before the first calorimetry period, 72 dBA before the second period, and 75 dBA before the third calorimetry period. There was no difference across treatments.

The average noise level within the rat cages in the calorimeters is presented in Table 3. The calorimeter noise levels were around 75 dBA the first period, 82 dBA the second period, and 81 dBA the third period.

Light Intensity: The average light level within the rat cages in the calorimeters is presented in Table 3. The calorimeter light levels were around 15 lux during the first period, 17 lux the second period, and 17 lux the third period.

BIOLOGICAL VARIABLES MEASURED DAILY AND WEEKLY

Rat Body Weight: Diet treatments or change in diet did not affect body weight of the rats. All of the RFB treatments (B90, B60, and B30) followed the same growth curve as the C rats and there were no diet

effects on body weight at any of the weekly comparisons (Table 11, Figure 5). The same diet treatment pattern was shown for the average daily gain (ADG) (Table 12).

Feed Consumption: A comparison of weekly means of feed consumption (ADF=g of feed/rat/day) over the entire experimental period showed no significant effect due to diet treatment (Table 13). A similar comparison of food intake for those rats that remained on their respective diet for the entire 90-day experiment (B90vsC) is shown in Table 13A; again there was no significant affect for the entire 90-day period. However, during the first 30-day feeding period (0-30), feed consumption was greater for the B90 treatment when compared to C fed animals. During the next two feeding periods (30-60 and 60-90), there were no consistent dietary treatment effects on feed and gain relationships (Table 14A and 14B, Figure 6, 7a and 7b).

Analysis of feed consumption on a weekly basis reflected a consistent difference in feed consumption between the C and B90 treatments, especially during the rapid growth period (feeding period 0-30) of the rats (Figures 5, 6 and 7a). During this 0-30 period, fresh RFB was added more frequently than during the remainder of the experiment; therefore, the difference in food consumption may be reflective of a difference in evaporative water loss from the RFB with time in the rat cage. There was an increase in week to week variance in feed consumption during the remaining feeding periods, and the pattern was much less consistent. One obvious reason for the variance was related to disruption of the rats' routine and general habitat during the calorimetry periods (week 5 and 9). Data from part of week 5 was before the diet change that occurred after the first 30-day period and part after the change. Consequently, for analysis purposes the first feeding period (0-30) was considered as weeks 1 through 4, the second feeding period (30-60) was weeks 6 through 9 and the third feeding period (60-90) was weeks 10 through 13. It can be seen that during week 9, feed consumption was reduced and was followed by a compensatory increase in feed intake during week 10. This pattern also occurred at weeks 5 and 6 (Figure 6).

Appetite was apparently not adversely influenced by change in diet form C to RFB (treatments B60 and B30). There were no weekly periods in which the feed consumption of those transferred from C to RFB treatment was different from their respective controls. After the transfer from C to RFB, the transferred rats (B60 and B30) showed the same ADF as the B90 groups. Before the change from C to RFB, the B60 and B30 cages had a feed consumption level the same as the C treatments. Gain to feed ratio followed an inverse pattern of response over the experimental period when compared to ADG. Since gain was very uniform across all diets, weekly gain to feed ratio between any of the diets or in response to change in diet reflects differences in feed intake (Table 15, Figures 7a and 7b).

Water Consumption: Water consumption was greater for the chow fed rats at essentially all weekly periods and over the entire feeding period (Table 16, Figure 8). After the change in diet from C to RFB during week 5, water consumption for the B60 rats was intermediate to the C and B90 treatments during the following two weeks. After the diet change at week 9, water consumption of the B30 rats was lower than the C treatment. Before the week 9 change in diet, the water intake for the B30 rats was the same as the C. Mean water consumption for the B30 treatment was 31.8 ml/rat/day during week 8 and 24.5 during week 10.

Water consumption and feed consumption were inversely related and especially obvious during the first feeding period (0-30). The change in water consumption following the dietary source change was much more apparent for water consumption than was seen for feed consumption. A comparison of the treatments that remained on the C or RFB diet throughout the experimental period (C and B90) showed that the C rats ate 2.7 g less feed and drank 7.0 ml more water on a daily basis (Table 13 and 17). The RFB diet had a much higher (27%) water content than the C (9%) diet; consequently, when the RFB rats were consuming larger volumes of feed to attain their daily nutrients, they were also meeting part of their daily water requirements. Since the RFB diet tended to dry and lose water at different rates over time when placed in the rat cage, it was not possible to get an accurate measure of the daily water intake that was provided by the RFB diet. However, on average and over the entire experimental period, water intake was around 23% lower for the B90 treatment when compared to C. (Table 17).

Fecal and Waste Production: One of the most obvious differences between dietary treatments was the volume and weight of fecal and waste materials produced. Rats on the chow diet produced a much greater volume and weight of waste than the RFB fed animals (Table 18). On a rat/day basis the C rats produced a 275% greater volume (ml) of waste, and it weighed 255% more than the waste from the RFB diet. Not all of the waste was feces, and the C diet tended to produce more feed waste. However, a sample of only fecal material (equal numbers of fecal pellets per treatment) showed that the C treatment fecal pellets were larger and ten randomly selected fecal pellets weighed 1.82 ± 0.093 g for the C treatment and 1.34 ± 0.11 for the RFB.

The increased fecal mass produced by the C treatment is inversely related to treatment differences in feed intake. There are several possible reasons for this difference. For example: 1) the C diet was much less processed (more coarsely ground) than the RFB, therefore, maybe less digestible and 2) the RFB diet was higher in moisture, therefore, less dense in nutrients per unit weight. In an attempt to better

understand the feed intake and waste production relationship, the urine and fecal constituents from the B90 and C treatments will be analyzed in a supplemental experiment.

BIOLOGICAL VARIABLES MEASURED AT THIRTY-DAY INTERVALS

Calorimetry: Metabolic measurements of O₂ consumption and CO₂ production are shown in Table 19. Heat production and RQ were calculated from the O₂ and CO₂ values and are also shown in Table 19. All metabolic measurements were lower during the 90-day calorimetry period, and RQ increased between each calorimetry period. Light:Dark cycle had the most dramatic on all metabolic measurements but had no apparent effect on RQ.

Mean difference in metabolic rate (Kcal/hr/Kg) between the daily light and dark periods was about 20%. Generally an expected 10% difference in post-absorptive resting metabolic rate is anticipated between the sleep-wake cycle. The greater difference measured between the light and dark period in this experiment probably reflects the fact that, in addition to being active during the dark period, this is the time when the greatest amount of food consumption occurs.

During the first two calorimetry periods, mean 24-hr metabolic rate was about 20-25% greater than many values reported in the literature (Altman and Dittmer, 1966). Unlike the rats used in this experiment, metabolic values often reported in the literature are taken from mature post-absorptive resting metabolic rate animals. Literature values also tend to be obtained from samples taken during the light part of the day and do not reflect an integration of the entire daily energy conversion process. Additionally during these 30- and 60-day calorimetry periods the rats were accumulating metabolically stored energy (body mass). During the last calorimetry period, when body growth rate reached a plateau, mean daily heat production was around 10-15% greater for these ad libitum fed rats, when compared to resting metabolic rates reported in the literature. The lower metabolic rate observed in all measurements during the 90-day calorimetry period, which coincided with the more stable body weight period, is probably more reflective of actual oxidative heat production of ad libitum fed rats.

The increase in RQ during each successive measurement period is probably reflective of anabolic metabolism to a greater extent than catabolic processes. When fat is being utilized for metabolic energy purposes RQ should be around 0.70 and RQ should be around 1.0 when carbohydrate is being oxidized. When the animal is storing nutrient energy in the form of total body growth and consuming a balanced ration, the RQ is generally between 0.75 and 0.95. However, when fatty tissue is being synthesized from carbohydrate, RQ may be greater than 1. Since the rats were fed a balanced nutrient diet, a mixed RQ

between 0.70 and 1.0 should be expressed. Therefore, the increase in RQ observed as the animals attained a mature body weight is probably reflective of an increase in body fat.

Moisture Production: Tables 20 and 21 show total moisture production for the 60- and 90-day calorimetry periods. Results for the 30-day calorimetry tests are not available due to numerous problems in the initial relative humidity control system and in the handling of the desiccant. There were no significant differences found between the diet treatments for either of the calorimetry periods. The 90-day calorimetry period had a higher moisture production than the 60-day calorimetry period. Metabolic water was estimated (Table 19) and would account for about 20.0% of the total moisture produced.

Gastrointestinal Tract Measurements:

Weight Weights (g) of gastrointestinal tracts with contents are presented in Table 22. Full gastrointestinal tract (GI) weights of chow (C) and B90 rats increased significantly with time. Following the switch from C to RFB, full GI weights of B60 and B30 rats significantly decreased with time. Full GI weights of C rats were significantly greater than RFB rats following all three periods.

Weights (g) of gastrointestinal tracts without contents are presented in Table 23. Empty GI weights of C, B90, and B60 rats increased significantly with time. Empty GI weights of B60 and B30 rats decreased significantly following the switch from C to RFB. Empty GI weights of C rats were significantly greater than RFB rats following periods 1 and 3.

Length Lengths (cm) of gastrointestinal tracts are presented in Table 24. GI lengths of C, B90, and B30 rats increased significantly with time. A non-significant reduction in GI length as observed in B60 and B30 rats following the switch from C to RFB. GI's of C rats were significantly longer than RFB rats following all three periods.

Gut Associated Lymphoid Tissue (GALT):

Numbers of Peyer's Patches Numbers of Peyer's patches in the gastrointestinal tract are presented in Table 25. The number of Peyer's patches significantly increased in all treatments with time. Switching from C to RFB did not affect the frequency of Peyer's patches. B90 rats exhibited significantly fewer Peyer's patches than B60 and B30 rats following period 1. No significant treatment differences were detected following periods 2 or 3.

Peyer's Patch Area (mm²) The size (area, mm²/patch) of Peyer's patches of duodenum are presented in Table 26. No significant changes in patch area were detected in C, B90, and B30 rats over time. However, patch area of B60 rats decreased significantly over time. No significant treatment differences were detected following all three periods.

The size (area, mm²/patch) of Peyer's patches of the jejunum are presented in Table 27. No significant changes in patch area were detected over time, regardless of treatment. C rats exhibited significantly larger patches than B30 rats following period 2. No significant treatment differences were detected following periods 1 and 3.

The size (area, mm²/patch) of Peyer's patches of the ileum are presented in Table 28. No significant changes in patch area were detected in C, B90, and B30 rats over time. However, patch area of B60 rats decreased significantly over time. B60 rats exhibited significantly larger patch areas than B90 rats following period 1. No significant treatment differences were detected following periods 2 and 3.

Lymphocyte Infiltration of Intestinal Villi Lymphocyte infiltration of duodenal intestinal villi is presented in Table 29. Infiltration increased significantly in C, B60, and B30 rats with time. No significant changes were detected in B90 rats with time. C rats exhibited significantly more infiltration compared to B90 rats following period 2. No significant treatment (C vs RFB) differences were detected following periods 2 and 3.

Lymphocyte infiltration of jejunal intestinal villi is presented in Table 30. C rats exhibited significantly higher infiltration with time. C rats exhibited significantly less infiltration compared to B60 and B30 rats with time. C rats exhibited significantly less infiltration compared to B60 and B30 rats following period 1. No significant treatment differences were detected following periods 2 and 3.

Lymphocyte infiltration of the ileal intestinal villi is presented in Table 31. Infiltration in B90 rats increased significantly following period 2 but decreased significantly following period 3. No significant changes in infiltration were detected for C, B60, or B30 rats with time. No significant treatment (C vs RFB) differences were detected following all three periods.

The observation that full GI weights of C rats were greater than RFB rats, following all three periods, is probably related to the higher crude fiber content of the C diet. This would also explain the fact that full GI weights of B60 and B30 rats decreased after they were switched from C to RFB. The observation that empty GI weights and GI lengths of C and RFB rats increased with time simply indicates somatic growth. Empty GI weights and GI lengths of C rats, being greater than RFB rats suggests higher digestibility and/or absorbability of the RFB diet. This may explain the finding that empty GI weights of B60 and B30 rats decreased after they were switched from C to RFB. These reductions in empty GI weights are correlated to a reduction in GI length.

It has been well established that immune functions decline with age (Makinodan, 1980). However, the effects of age on GALT seem to contradict this generalization. In the present study, the numbers of Peyer's patches increased with age regardless of dietary treatment. Similar age related changes have been

reported by Lochmiller et al. (1992) who documented increased numbers and size of Peyer's patches in the small intestine of the cotton rat (*Sigmodon Hispidus*). However, patch area did not increase with age in the present study. In fact, duodenal and ileal Peyer's patch area in B60 rats decreased with age. In addition, the synthesis of immunoglobulins by B cells from Peyer's patches was significantly greater in old mice than in young mice (Hosoda et al., 1992).

There is evidence which suggests that diet quality, specifically dietary protein levels, can affect relative weights of Peyer's patch tissue (Lochmiller et al., 1992). However, no consistent changes in patch area were detected between dietary treatments in the present study. Since the numbers of Peyer's patches increased with age in all dietary treatments, it was expected that lymphocyte infiltration would also increase with age. However, no consistent changes in lymphocyte infiltration were detected by age or dietary treatment in the present study.

GENERAL SUMMARY

1. Caging System and Environment – There were no differences between physical variables between cages over the entire experimental period.
2. Calorimetry System – Three identical calorimeters were constructed and tested prior to the experiment. There were not differences between metabolic measurements between calorimeters. During calorimetry tests with the experimental rats, diet treatments were systematically assigned to all calorimeters, following an initial random treatment assignment.
3. Diet Effects on Physical Variables – There was no diet effects on moisture production or particulate production. Variance in dust particle size and number is inherently high and a different system of statistical analysis is needed in order to evaluate treatment effects if this variable is of importance in Space Science.
4. Biological Variables:
 - a. Body Weight Gain and Energy Conversion – Metabolic rate and total body growth were not affected by diet. Daily L:D cycle had the most significant affect on metabolism; age also had significant metabolic affect. Feed consumption was significantly greater for the RFB treatments, especially during the first thirty days. Evaporation rates from the RFB may be a confounding variable in this measurement.
 - b. Water Consumption – Rats receiving the RFB drank less water than those receiving the C diet. Change in diet was rapidly followed by a change in water intake.

- c. Fecal and Waste Volume -- Fecal weight and volume was consistently 2X greater for the C fed rats.
- d. Gastrointestinal Tissue -- Rats receiving C expressed greater GI tissue mass compared to RFB. Rats transferred from C to RFB exhibited reductions in length and weight of GI tract. No consistent changes in GALT number or area, or lymphocyte infiltration of intestinal villi were observed between dietary treatments.

GENERAL CONCLUSION

Total body growth was uniformly supported by both RFB and C diets. Energy conversion as indicated by all metabolic parameters were also the same for both diets. Efficiency of energy conversion was affected by diet; however, moisture content by the RFB appears to be a confounding factor for interpretation of these results. Change in diet had no apparent detrimental affects and rats rapidly adjusted to the transfer from C to RFB diets, regardless of age.

Fecal volume was dramatically and consistently lower for the RFB rats. Water consumption was also consistently lower for the RFB rats. Supplemental experiments are being conducted to help explain these differences.

GI tissue was significantly less in the RFB rats. In fact it appeared to regress after a shift from the C to RFB diet. Gut associated lymphatic tissue was not affected by diet.

REFERENCES

- Altman, P.L., and D.S. Dittmer, 1966. Environmental Biol: Biol. Handbooks, FASEB.
- Hosoda, S., T. Bamba, S. Nakago, Y. Fujiyama, S. Senda, and M. Hisata, 1992. Age-related changes in the gastrointestinal tract. Nut. Rev. 40:374-377.
- Lochmiller, R.L., M.R. Vestey, and D. Nash, 1992. Gut associated lymphoid tissue in the cotton rat (*Sigmodon Hispidus*) and its response to protein restriction. J. Wildlife Dis. 28:1-9.
- Makinodan, T.K., 1980. Age influence on the immune system. Adv. Immunol. 29:287-330.

Table 1. Comparison of feed components.

| Ingredient | Diets* | |
|-------------|----------|---------|
| | Chow (%) | RFB (%) |
| Protein | 21.2 | 21.5 |
| Fat | 5.6 | 4.8 |
| Crude fiber | 4.4 | 3.8 |
| Moisture | 8.8 | 26.9 |
| Calcium | 0.82 | 0.73 |
| Phosphorus | 0.63 | 0.57 |
| Ash | 7.0 | — |
| ME (Kcal/g) | 3.41 | 3.75 |

* RFB = rodent food bar – Harlan Teklad diet TD 93062. This diet was 8.8% moisture prior to processing. Processing of Teklad diet into RFB was by the American Institute of Baking, Manhattan, KS.

Chow = Certified rodent diet - 5002; Purina Mills, Inc.

Table 2. Acclimation chamber environmental variables.

| Environmental Index | Diet Treatments ¹ | |
|-----------------------------|------------------------------|----------------------|
| | Chow [Mean (S.D.)] | RFB [Mean (S.D.)] |
| <i>Feeding Period 0-30</i> | | |
| Air Temperature, C | 22.1* (0.68) | 22.1* (0.68) |
| Relative Humidity, % | 57* (19.6) | 57* (19.6) |
| Air Velocity, m/s | 0.125 (.045) | 0.124 (.071) |
| Noise Level, dBA | 75(1.7) | 75 (1.6) |
| Ammonia Level, ppm | 3.2 (0.41) | 3.7 (0.52) |
| <i>Feeding Period 30-60</i> | | |
| Air Temperature, C | 22.3* (0.63) | 22.3* (0.63) |
| Relative Humidity, % | 53* (16.9) | 53* (16.9) |
| Air Velocity, m/s | 0.143 (.039) | 0.136 (.048) |
| Noise Level, dBA | 72 (6.1) | 72 (7.8) |
| Ammonia Level, ppm | 1.4 (1.5) | 1.6 (1.5) |
| <i>Feeding Period 60-90</i> | | |
| Air Temperature, C | 21.6* (1.56) | 21.6* (1.56) |
| Relative Humidity, % | 53* (10.9) | 53* (10.9) |
| Air Velocity, m/s | 0.148 (.045) | 0.125 (.043) |
| Noise Level, dBA | 75 (1.7) | 76 (2.1) |
| Ammonia Level, ppm | 0 (-) | 0 (-) |

* Measurements were taken in one location in acclimation chamber and could not be separated according to treatment.

¹ See Table 1 for diets.

Table 3. Calorimeter environmental variables.

| Environmental Index | Calorimeter Chamber [Mean (S.D.)] | Diet Treatments | |
|---|--------------------------------------|-----------------------|----------------------|
| | | Chow [Mean (S.D.)] | RFB [Mean (S.D.)] |
| <i>First calorimetry (5/2/94 to 5/5/94)</i> | | | |
| Air Temperature, C | 16.2 (0.93) | 22.2 (0.56) | 22.1 (1.75) |
| Relative Humidity, % | N/A | 60 (9.8) | 59 (7.3) |
| Air Velocity, m/s | N/A | 0.129 (0.003) | 0.128 (0.005) |
| Noise Level, dBA | N/A | 74.5* (6.9) | 74.5* (6.9) |
| Light Level, lux | N/A | 14.5* (1.64) | 14.5* (1.64) |
| Ammonia Level, ppm | 1.5 (1.65) | 0.3 (0.97) | 0.5 (1.31) |
| <i>Second calorimetry (5/31/94 to 6/5/94)</i> | | | |
| Air Temperature, C | 16.8 (1.30) | 20.9 (0.65) | 20.8 (0.68) |
| Relative Humidity, % | 64 | 64 (9.3) | 65 (10.4) |
| Air Velocity, m/s | N/A | 0.141 (0.008) | 0.141 (0.012) |
| Noise Level, dBA | N/A | 82.1* (2.34) | 82.1* (2.34) |
| Light Level, lux | N/A | 16.8* (2.48) | 16.8* (2.48) |
| Ammonia Level, ppm | 3.9 (3.79) | 3.5 (3.21) | 3.4 (2.99) |
| <i>Third calorimetry (6/30/94 to 7/7/94)</i> | | | |
| Air Temperature, C | 17.9 (0.46) | 21.1 (0.71) | 21.0 (1.19) |
| Relative Humidity, % | 63 | 55 (1.0) | 54 (4.8) |
| Air Velocity, m/s | N/A | 0.133 (0.005) | 0.135 (0.006) |
| Noise Level, dBA | N/A | 80.7* (2.90) | 80.7* (2.90) |
| Light Level, lux | N/A | 16.7* (2.16) | 16.7* (2.16) |
| Ammonia Level, ppm | 1.2 (1.70) | 0.8 (1.31) | 0.7 (1.28) |

* Measurements were taken before and after each set of calorimetry runs and could not be separated according to treatment.

Table 4. Acclimation chamber dust weight data.

| Date Sampled | Particulate Mass (mg/m ³ of air) |
|--------------|--|
| 5/03/94 | 0.124 |
| 5/10/94 | 0.106 |
| 5/17/94 | 0.092 |
| 5/24/94 | 0.127 |
| 5/31/94 | 0.058 |
| 6/07/94 | 0.039 |
| 6/14/94 | 0.071 |
| 6/21/94 | 0.088 |
| 6/28/94 | - |
| 7/05/94 | 0.114 |
| Mean | 0.091 |
| S.D. | 0.030 |

Table 5. Particle counts in acclimation chamber.

| Date | Particles/m ³ air | | |
|---------|---------------------------------|------------|-----------|
| | Size Range (μm) | Mean | S.D. |
| 5/10/94 | > 10 | 358 | 34 |
| | > 5 | 1,238 | 234 |
| | > 1 | 40,261 | 4,106 |
| | > 0.7 | 172,286 | 16,827 |
| | > 0.5 | 765,247 | 38,889 |
| | > 0.3 | 3,497,781 | 81,983 |
| 5/17/94 | > 10 | 324 | 132 |
| | > 5 | 773 | 24 |
| | > 1 | 51,302 | 8,530 |
| | > 0.7 | 219,018 | 24,545 |
| | > 0.5 | 1,215,003 | 83,089 |
| | > 0.3 | 6,178,185 | 241,069 |
| 5/24/94 | > 10 | 93 | 68 |
| | > 5 | 470 | 135 |
| | > 1 | 56,049 | 7,370 |
| | > 0.7 | 334,458 | 42,599 |
| | > 0.5 | 3,180,747 | 322,036 |
| | > 0.3 | 15,754,800 | 466,995 |
| 5/30/94 | > 10 | 88 | 49 |
| | > 5 | 333 | 57 |
| | > 1 | 56,264 | 6,997 |
| | > 0.7 | 405,657 | 51,108 |
| | > 0.5 | 4,085,921 | 401,962 |
| | > 0.3 | 15,406,510 | 761,750 |
| 6/9/94 | > 10 | 49 | 46 |
| | > 5 | 415 | 135 |
| | > 1 | 69,871 | 5,929 |
| | > 0.7 | 528,715 | 22,706 |
| | > 0.5 | 4,267,648 | 118,441 |
| | > 0.3 | 15,306,800 | 224,393 |
| 6/15/94 | > 10 | 42 | 28 |
| | > 5 | 249 | 42 |
| | > 1 | 111,093 | 8,127 |
| | > 0.7 | 569,741 | 33,816 |
| | > 0.5 | 3,768,059 | 62,783 |
| | > 0.3 | 17,036,900 | 146,047 |
| 6/24/95 | > 10 | 3,879 | 3,148 |
| | > 5 | 6,654 | 6,036 |
| | > 1 | 88,883 | 70,465 |
| | > 0.7 | 378,360 | 165,355 |
| | > 0.5 | 2,773,562 | 387,205 |
| | > 0.3 | 15,562,080 | 386,037 |
| 7/5/94 | > 10 | 18 | 18 |
| | > 5 | 3,011 | 602 |
| | > 1 | 8,461,781 | 1,267,729 |
| | > 0.7 | 20,205,470 | 1,077,101 |
| | > 0.5 | 27,085,100 | 448,772 |
| | > 0.3 | 28,398,540 | 333,413 |

Table 6. Particle counts in the calorimeters during the first calorimetry.

| 4-hr Sample Period | Size Range (μm)* | Particles/ m^3 air | | | | | |
|--------------------------|-------------------------------------|-----------------------------|-----------|-----------------|-----------|-----------|-----------|
| | | Calorimetry Chamber | | Diet Treatments | | | |
| | | Mean | S.D. | Chow | | RFB | |
| | | | | Mean | S.D. | Mean | S.D. |
| 1 | >10 | 6,734 | 5,908 | 165 | 142 | 154 | 117 |
| | >5 | 20,159 | 12,597 | 793 | 706 | 1,003 | 682 |
| | >1 | 391,651 | 161,137 | 215,580 | 310,203 | 354,539 | 346,926 |
| | >0.7 | 1,122,522 | 389,691 | 762,158 | 1,149,746 | 1,112,779 | 1,128,295 |
| | >0.5 | 4,822,954 | 1,331,715 | 2,417,699 | 2,914,430 | 3,471,422 | 2,814,400 |
| | >0.3 | 12,282,040 | 429,610 | 5,815,656 | 4,666,952 | 8,149,166 | 4,460,295 |
| | 2 | >10 | 3,940 | 1,022 | 82 | 114 | 25 |
| >5 | | 11,824 | 3,822 | 296 | 287 | 908 | 1,566 |
| >1 | | 154,683 | 40,968 | 57,260 | 45,809 | 159,596 | 183,867 |
| >0.7 | | 475,863 | 78,327 | 167,375 | 67,524 | 551,998 | 584,628 |
| >0.5 | | 2,839,555 | 1,248,207 | 667,108 | 220,741 | 1,951,180 | 1,726,968 |
| >0.3 | | 13,132,706 | 4,194,432 | 3,201,159 | 1,117,147 | 6,044,666 | 3,189,539 |
| 3 | | >10 | 2,410 | 587 | 62 | 67 | 48 |
| | >5 | 7,347 | 2,175 | 1,261 | 2,060 | 278 | 337 |
| | >1 | 151,621 | 100,750 | 357,368 | 653,293 | 41,411 | 23,612 |
| | >0.7 | 452,389 | 241,541 | 705,014 | 1,070,846 | 163,838 | 95,212 |
| | >0.5 | 2,178,744 | 656,354 | 1,712,026 | 1,730,183 | 857,792 | 550,519 |
| | >0.3 | 12,432,105 | 3,466,505 | 4,913,004 | 1,714,636 | 3,887,941 | 1,490,482 |
| | 4 | >10 | 1,829 | 588 | 41 | 26 | 24 |
| >5 | | 6,166 | 1,766 | 410 | 221 | 232 | 147 |
| >1 | | 117,119 | 25,115 | 138,656 | 91,078 | 102,323 | 102,421 |
| >0.7 | | 384,712 | 62,740 | 548,655 | 388,404 | 437,905 | 418,294 |
| >0.5 | | 2,200,475 | 627,170 | 2,075,572 | 1,474,159 | 2,020,614 | 1,457,362 |
| >0.3 | | 12,906,415 | 2,897,974 | 6,831,736 | 2,245,419 | 6,639,795 | 2,518,879 |
| 5 | | >10 | 245 | 143 | 21 | 13 | 14 |
| | >5 | 1,405 | 907 | 2,626 | 5,364 | 2,530 | 5,406 |
| | >1 | 75,958 | 45,586 | 524,053 | 995,441 | 486,779 | 1,011,223 |
| | >0.7 | 302,894 | 174,541 | 1,285,075 | 2,142,012 | 1,134,150 | 2,203,833 |
| | >0.5 | 2,197,100 | 1,379,413 | 4,334,779 | 5,030,825 | 3,448,997 | 5,378,383 |
| | >0.3 | 11,458,071 | 6,797,986 | 12,795,092 | 6,696,400 | 9,180,311 | 8,882,751 |
| | 6 | >10 | 2,753 | 3,377 | 12 | 9 | 5 |
| >5 | | 6,805 | 7,890 | 125 | 76 | 79 | 63 |
| >1 | | 85,499 | 64,977 | 58,909 | 42,031 | 30,013 | 25,340 |
| >0.7 | | 376,714 | 216,041 | 272,421 | 188,024 | 139,277 | 104,262 |
| >0.5 | | 3,071,010 | 2,066,340 | 2,098,985 | 1,226,849 | 1,266,454 | 926,355 |
| >0.3 | | 12,358,626 | 7,310,558 | 8,238,143 | 4,294,366 | 5,890,130 | 4,188,711 |

*Total number of particles counted that were greater than the diameter shown (includes the particles shown in the larger ranges).

Table 7. Particle counts in the calorimeters during the second calorimetry.

| 4-hr Sample Period | Size Range (μm)* | Particles/ m^3 air | | | | | |
|--------------------------|-------------------------------------|-----------------------------|-----------|-----------------|-----------|-----------|-----------|
| | | Calorimetry Chamber | | Diet Treatments | | | |
| | | Mean | S.D. | Chow | | RFB | |
| | | Mean | S.D. | Mean | S.D. | Mean | S.D. |
| 1 | >10 | 2,339 | 2,187 | 340 | 373 | 86 | 103 |
| | >5 | 8,345 | 6,823 | 979 | 927 | 945 | 811 |
| | >1 | 272,719 | 123,378 | 92,991 | 42,444 | 217,947 | 220,721 |
| | >0.7 | 1,184,251 | 1,098,721 | 313,441 | 106,879 | 745,143 | 826,562 |
| | >0.5 | 4,869,300 | 4,501,559 | 1,356,300 | 374,266 | 2,540,138 | 2,275,251 |
| | >0.3 | 11,918,223 | 6,331,671 | 4,697,957 | 1,815,103 | 6,705,571 | 4,346,238 |
| 2 | >10 | 1,342 | 1,239 | 184 | 304 | 15 | 19 |
| | >5 | 4,027 | 3,233 | 907 | 1,212 | 191 | 217 |
| | >1 | 114,114 | 36,630 | 177,198 | 339,130 | 33,728 | 29,830 |
| | >0.7 | 739,994 | 594,961 | 529,542 | 911,493 | 139,913 | 85,731 |
| | >0.5 | 4,579,786 | 3,741,590 | 1,642,200 | 2,021,794 | 827,769 | 565,626 |
| | >0.3 | 13,247,555 | 6,988,962 | 5,367,688 | 4,835,409 | 4,256,670 | 3,154,485 |
| 3 | >10 | 1,119 | 890 | 90 | 103 | 31 | 55 |
| | >5 | 3,231 | 2,587 | 431 | 461 | 240 | 285 |
| | >1 | 146,530 | 108,987 | 67,198 | 73,510 | 31,100 | 16,585 |
| | >0.7 | 1,146,310 | 1,271,375 | 261,203 | 253,822 | 160,809 | 105,614 |
| | >0.5 | 5,615,987 | 5,857,043 | 1,380,912 | 1,211,341 | 1,127,133 | 1,054,367 |
| | >0.3 | 12,979,994 | 8,494,822 | 5,857,508 | 4,988,992 | 5,436,798 | 4,454,283 |
| 4 | >10 | 1,190 | 672 | 117 | 98 | 12 | 10 |
| | >5 | 3,676 | 2,033 | 361 | 239 | 235 | 124 |
| | >1 | 103,623 | 19,166 | 78,155 | 56,407 | 69,735 | 78,511 |
| | >0.7 | 434,161 | 187,017 | 304,291 | 166,187 | 301,826 | 322,451 |
| | >0.5 | 2,449,683 | 1,736,129 | 1,275,884 | 429,753 | 1,469,637 | 1,177,661 |
| | >0.3 | 13,441,514 | 7,328,084 | 4,467,403 | 1,672,237 | 5,421,912 | 2,655,488 |
| 5 | >10 | 2,277 | 2,829 | 95 | 141 | 12 | 11 |
| | >5 | 5,790 | 4,809 | 313 | 226 | 1,523 | 3,957 |
| | >1 | 116,122 | 44,570 | 64,685 | 33,157 | 307,553 | 736,540 |
| | >0.7 | 336,615 | 99,709 | 262,548 | 110,827 | 779,849 | 1,596,983 |
| | >0.5 | 1,464,442 | 915,977 | 1,255,907 | 452,142 | 2,430,862 | 3,934,721 |
| | >0.3 | 7,039,729 | 4,914,646 | 5,897,141 | 2,714,914 | 6,971,476 | 6,455,396 |
| 6 | >10 | 3,219 | 3,668 | 9 | 6 | 7 | 7 |
| | >5 | 6,547 | 6,193 | 224 | 148 | 236 | 188 |
| | >1 | 75,918 | 45,979 | 96,634 | 64,490 | 53,934 | 27,247 |
| | >0.7 | 278,472 | 178,872 | 459,562 | 275,933 | 245,941 | 129,257 |
| | >0.5 | 1,566,324 | 1,252,778 | 2,845,620 | 1,324,008 | 1,781,042 | 901,813 |
| | >0.3 | 7,545,717 | 6,001,675 | 10,561,415 | 3,078,898 | 8,573,180 | 4,543,287 |

*Total number of particles counted that were greater than the diameter shown (includes the particles shown in the larger ranges).

Table 8. Particle counts in the calorimeters during the third calorimetry.

| 4-hr Sample Period | Size Range (μm)* | Particles/ m^3 air | | | | | |
|--------------------------|-------------------------------------|-----------------------------|-------------|-----------------|-----------|------------|-----------|
| | | Calorimetry Chamber | | Diet Treatments | | | |
| | | Mean | S.D. | Chow | | RFB | |
| | | | | Mean | S.D. | Mean | S.D. |
| 1 | >10 | 1,711 | 1,596 | 81 | 40 | 33 | 41 |
| | >5 | 6,106 | 5,159 | 893 | 672 | 691 | 802 |
| | >1 | 1,258,916 | 2,037,906 | 190,663 | 218,857 | 258,529 | 617,103 |
| | >0.7 | 5,832,943 | 5,241,780 | 1,414,138 | 1,823,533 | 1,567,695 | 2,790,556 |
| | >0.5 | 22,653,376 | 14,996,980 | 7,132,211 | 5,998,614 | 7,280,238 | 5,933,869 |
| | >0.3 | 23,925,019 | 3,894,318 | 16,736,904 | 7,867,140 | 17,386,004 | 7,207,657 |
| 2 | >10 | 1,372 | 1,614 | 67 | 63 | 75 | 176 |
| | >5 | 7,169 | 11,748 | 402 | 181 | 1,491 | 4,053 |
| | >1 | 6,026,619 | 13,298,716 | 67,974 | 34,716 | 184,227 | 473,334 |
| | >0.7 | 30,218,613 | 61,685,331 | 568,443 | 447,503 | 737,507 | 991,666 |
| | >0.5 | 58,088,167 | 109,321,929 | 4,981,318 | 3,518,546 | 5,069,844 | 2,560,003 |
| | >0.3 | 69,169,758 | 120,670,316 | 16,155,634 | 6,701,678 | 16,420,599 | 5,317,646 |
| 3 | >10 | 1,793 | 1,336 | 148 | 199 | 101 | 220 |
| | >5 | 5,138 | 4,340 | 586 | 340 | 1,773 | 5,481 |
| | >1 | 1,187,625 | 2,672,544 | 77,437 | 88,358 | 122,128 | 247,672 |
| | >0.7 | 3,668,212 | 5,866,946 | 632,303 | 1,034,306 | 566,782 | 744,082 |
| | >0.5 | 11,289,182 | 6,520,531 | 3,409,350 | 4,913,124 | 2,832,664 | 3,343,218 |
| | >0.3 | 21,980,479 | 4,591,685 | 9,707,925 | 7,436,140 | 9,007,107 | 4,525,187 |
| 4 | >10 | 1,032 | 702 | 258 | 317 | 37 | 35 |
| | >5 | 2,682 | 1,425 | 743 | 466 | 480 | 254 |
| | >1 | 424,177 | 878,684 | 58,360 | 22,290 | 60,050 | 21,619 |
| | >0.7 | 2,008,377 | 3,830,463 | 265,317 | 176,942 | 244,171 | 130,771 |
| | >0.5 | 5,433,205 | 2,601,947 | 1,487,149 | 1,395,997 | 1,455,124 | 1,279,934 |
| | >0.3 | 18,275,119 | 4,914,052 | 5,722,122 | 4,342,757 | 6,262,897 | 3,842,252 |
| 5 | >10 | 496 | 973 | 821 | 631 | 46 | 29 |
| | >5 | 1,760 | 2,116 | 1,514 | 936 | 445 | 252 |
| | >1 | 100,749 | 16,238 | 50,720 | 20,326 | 48,512 | 20,993 |
| | >0.7 | 740,808 | 275,967 | 199,301 | 74,397 | 195,664 | 88,010 |
| | >0.5 | 5,819,337 | 2,190,397 | 1,062,532 | 434,063 | 1,238,946 | 613,297 |
| | >0.3 | 17,343,808 | 2,850,221 | 9,790,410 | 6,448,788 | 6,767,340 | 4,173,820 |
| 6 | >10 | 571 | 807 | 464 | 884 | 42 | 31 |
| | >5 | 1,734 | 1,818 | 936 | 1,260 | 366 | 174 |
| | >1 | 109,860 | 30,765 | 32,527 | 12,866 | 38,496 | 21,498 |
| | >0.7 | 866,128 | 498,824 | 150,560 | 52,682 | 170,740 | 87,539 |
| | >0.5 | 6,523,562 | 2,750,145 | 1,044,879 | 369,436 | 1,163,107 | 586,842 |
| | >0.3 | 18,506,765 | 3,390,081 | 5,354,094 | 1,991,989 | 5,813,330 | 2,904,176 |

*Total number of particles counted that were greater than the diameter shown (includes the particles shown in the larger ranges).

Table 9. Particle counts averaged over all calorimetry periods.

| Size Range (μm)* | Particles/m ³ air | | | | | |
|-------------------------------|------------------------------|------------|-----------------|-----------|------------|-----------|
| | Calorimetry Chamber | | Diet Treatments | | | |
| | Mean | S.D. | Chow | | RFB | |
| | Mean | S.D. | Mean | S.D. | Mean | S.D. |
| <i>First Calorimetry</i> | | | | | | |
| > 10 | 2,985 | 3,470 | 63 | 95 | 45 | 77 |
| > 5 | 8,953 | 8,658 | 915 | 2,512 | 838 | 2,464 |
| > 1 | 162,755 | 137,169 | 225,306 | 531,697 | 195,777 | 476,036 |
| > 0.7 | 519,182 | 354,240 | 623,445 | 1,158,166 | 589,991 | 1,128,817 |
| > 0.5 | 2,884,973 | 1,610,439 | 2,217,692 | 2,820,758 | 2,169,410 | 2,859,294 |
| > 0.3 | 12,428,327 | 4,822,551 | 6,965,800 | 4,993,672 | 6,632,001 | 5,038,240 |
| <i>Second Calorimetry</i> | | | | | | |
| > 10 | 1,838 | 2,200 | 147 | 241 | 29 | 57 |
| > 5 | 5,194 | 4,891 | 554 | 746 | 581 | 1,781 |
| > 1 | 141,833 | 98,648 | 96,115 | 156,054 | 122,827 | 342,449 |
| > 0.7 | 710,643 | 840,130 | 348,953 | 431,792 | 404,382 | 816,823 |
| > 0.5 | 3,533,544 | 3,956,810 | 1,554,403 | 1,232,506 | 1,691,100 | 2,158,653 |
| > 0.3 | 11,233,675 | 7,301,136 | 5,881,525 | 3,902,918 | 6,089,626 | 4,614,557 |
| <i>Third Calorimetry</i> | | | | | | |
| > 10 | 1,162 | 1,328 | 306 | 540 | 56 | 122 |
| > 5 | 4,098 | 6,067 | 846 | 818 | 874 | 2,873 |
| > 1 | 1,517,991 | 5,980,754 | 79,614 | 111,027 | 118,657 | 344,562 |
| > 0.7 | 7,221,014 | 27,492,386 | 538,344 | 979,078 | 580,427 | 1,346,219 |
| > 0.5 | 18,301,138 | 48,903,050 | 3,186,240 | 4,195,261 | 3,173,320 | 3,810,218 |
| > 0.3 | 28,200,158 | 52,736,984 | 10,577,848 | 7,613,619 | 10,276,213 | 6,821,789 |

* Total number of particles counted that were greater than the diameter shown (includes the particles shown in the larger ranges).

Table 10. Particle counts averaged over light and dark periods.

| Size Range (μm)* | Particles/ m^3 air | | | | | | | |
|-------------------------------|-----------------------------|-----------|-------------|-----------|--------------|-----------|-------------|-----------|
| | Diet Treatments | | | | | | | |
| | Chow | | | | RFB | | | |
| | Light Period | | Dark Period | | Light Period | | Dark Period | |
| | Mean | S.D. | Mean | S.D. | Mean | S.D. | Mean | S.D. |
| <i>First Calorimetry</i> | | | | | | | | |
| > 10 | 103 | 108 | 25 | 16 | 75 | 71 | 14 | 14 |
| > 5 | 783 | 1008 | 1,054 | 1,887 | 730 | 862 | 947 | 1,872 |
| > 1 | 210,069 | 336,435 | 240,539 | 375,850 | 185,182 | 184,802 | 206,372 | 379,661 |
| > 0.7 | 544,849 | 762,706 | 702,050 | 906,147 | 609,538 | 602,712 | 570,444 | 908,796 |
| > 0.5 | 1,598,944 | 1,621,785 | 2,836,445 | 2,577,278 | 2,093,465 | 1,697,296 | 2,245,355 | 2,587,367 |
| > 0.3 | 4,643,273 | 2,499,578 | 9,288,324 | 4,412,062 | 6,027,257 | 3,046,772 | 7,236,745 | 5,196,781 |
| <i>Second Calorimetry</i> | | | | | | | | |
| > 10 | 205 | 260 | 73 | 82 | 44 | 59 | 10 | 9 |
| > 5 | 772 | 867 | 299 | 204 | 459 | 438 | 665 | 1,423 |
| > 1 | 112,462 | 151,695 | 79,825 | 51,351 | 94,258 | 89,046 | 143,740 | 280,766 |
| > 0.7 | 368,062 | 424,065 | 342,134 | 184,316 | 348,622 | 339,302 | 442,538 | 682,897 |
| > 0.5 | 1,459,804 | 1,202,467 | 1,792,470 | 735,301 | 1,498,347 | 1,298,415 | 1,893,847 | 2,004,732 |
| > 0.3 | 5,307,718 | 3,879,835 | 6,975,320 | 2,488,683 | 5,466,346 | 3,985,002 | 6,988,856 | 4,551,390 |
| <i>Third Calorimetry</i> | | | | | | | | |
| > 10 | 98 | 100 | 514 | 611 | 70 | 146 | 42 | 32 |
| > 5 | 627 | 398 | 1,065 | 887 | 1,318 | 3,446 | 430 | 227 |
| > 1 | 112,025 | 113,977 | 47,202 | 18,494 | 188,295 | 446,036 | 49,019 | 21,370 |
| > 0.7 | 871,628 | 1,101,780 | 205,059 | 101,341 | 957,328 | 1,508,768 | 203,525 | 102,107 |
| > 0.5 | 5,174,293 | 4,810,095 | 1,198,187 | 733,165 | 5,060,915 | 3,945,696 | 1,285,726 | 826,691 |
| > 0.3 | 14,200,155 | 7,334,986 | 6,955,542 | 4,261,178 | 14,271,237 | 5,683,497 | 6,281,189 | 3,640,082 |

*Total number of particles counted that were greater than the diameter shown (includes the particles shown in the larger ranges).

Table 11. Mean body weight of rats fed chow or RFB for different time periods.¹

| Weekly Period | Date | Diet Treatments ² | | | |
|---------------|------|------------------------------|-------------|-------------|-------------|
| | | Chow | B90 | B60 | B30* |
| 0 | 4-4 | 77.62±.78 | 78.25±.44 | 78.54±.47 | 78.05±.67 |
| 1 | 4-11 | 124.20±1.29 | 122.02±.87 | 124.95±1.04 | 124.56±.95 |
| 2 | 4-18 | 173.98±1.87 | 171.85±1.46 | 174.03±1.32 | 174.12±1.47 |
| 3 | 4-25 | 224.40±2.50 | 223.35±1.82 | 224.95±1.24 | 225.32±2.21 |
| 4 | 5-2 | 271.05 ±2.49 | 271.38±1.84 | 275.47±1.75 | 273.28±3.00 |
| 5 | 5-9 | 307.07±3.63 | 311.41±3.38 | 310.50±1.70 | 310.61±3.41 |
| 6 | 5-16 | 334.41±3.57 | 337.74±3.52 | 336.36±1.97 | 338.28±5.08 |
| 7 | 5-23 | 354.86±3.78 | 361.72±3.85 | 361.16±3.07 | 359.13±6.44 |
| 8 | 5-31 | 377.66±4.20 | 379.69±4.06 | 382.65±3.46 | 380.33±6.90 |
| 9 | 6-6 | 387.88±5.95 | 394.69±5.68 | 399.92±5.59 | 391.52±6.40 |
| 10 | 6-13 | 403.30±5.79 | 413.00±5.65 | 417.50±6.00 | 404.10±4.12 |
| 11 | 6-20 | 416.20±5.89 | 422.2±5.57 | 431.5±6.32 | 423.00±5.62 |
| 12 | 6-27 | 426.60±6.35 | 437.80±4.73 | 445.6±7.45 | 434.4±6.70 |
| 13 | 7-5 | 434.00±6.67 | 439.90±5.12 | 449.30±7.11 | 442.50±6.97 |

* Mean and standard error. Values with different superscripts differ significantly ($p < .05$) within period.

¹ See Table 1 for diets.

² Chow treatment received chow diet for all periods; n=8 cages.

B90 treatment received RFB diet for all periods; n=8 cages.

B60 treatment received chow diet until date 5-6 and RFB diet for the remaining periods; n=6 cages.

B30 treatment received chow diet until 6-6 and RFB diet for the remaining periods; n=6 cages.

Table 12. Average daily gain (g) of rats fed chow or RFB for different time periods.¹

| Weekly Period | Date | Diets Treatments ² | | | |
|---------------|------|-------------------------------|-------------------------|-------------------------|-------------------------|
| | | Chow | B90 | B60 | B30* |
| 0 | 4-4 | — | — | — | — |
| 1 | 4-11 | 6.65 ± .08 | 6.25 ± .07 ^a | 6.60 ± .11 | 6.63 ± .11 |
| 2 | 4-18 | 7.11 ± .10 | 7.11 ± .12 | 7.03 ± .09 | 7.07 ± .10 |
| 3 | 4-25 | 7.20 ± .12 | 7.35 ± .08 | 7.27 ± .08 | 7.33 ± .35 |
| 4 | 5-2 | 6.62 ± .06 | 6.86 ± .09 | 7.13 ± .18 | 6.98 ± .56 |
| 5 | 5-9 | 5.13 ± .30 | 5.73 ± .37 | 5.01 ± .14 | 5.33 ± .21 |
| 6 | 5-16 | 3.91 ± .09 | 3.78 ± .27 | 3.68 ± .14 | 3.95 ± .26 |
| 7 | 5-23 | 2.93 ± .07 ^a | 3.41 ± .10 ^b | 3.55 ± .18 ^b | 2.97 ± .24 ^a |
| 8 | 5-31 | 3.26 ± .11 ^a | 2.58 ± .20 | 3.07 ± .23 | 3.03 ± .14 |
| 9 | 6-6 | 1.82 ± .33 | 1.89 ± .38 | 2.16 ± .31 | 1.41 ± .27 |
| 10 | 6-13 | 2.57 ± .14 | 2.96 ± .26 | 2.95 ± .11 | 2.09 ± .73 |
| 11 | 6-20 | 1.84 ± .05 | 1.31 ± .49 | 2.00 ± .09 | 2.70 ± .62 |
| 12 | 6-27 | 1.47 ± .15 | 2.20 ± .75 | 2.02 ± .08 | 1.61 ± .53 |
| 13 | 7-5 | 1.06 ± .20 | .31 ± .54 | .54 ± .50 | 1.16 ± .08 |

* Mean and standard error. Values with different superscripts differ significantly ($p < .05$) within period.

¹ See Table 1 for diets.

² Chow treatment received chow diet for all periods; n=8 cages.

B90 treatment received RFB diet for all periods; n=8 cages.

B60 treatment received chow diet until date 5-6 and RFB diet for the remaining periods; n=6 cages.

B30 treatment received chow diet until 6-6 and RFB diet for the remaining periods; n=6 cages.

Table 13. Overall ANOVA daily feed consumption (g/rat/day).

One Factor ANOVA X_1 :TRTS Y_1 :f/d

Analysis of Variance Table

| Source | DF | Sum Squares | Mean Square | F-test |
|----------------|----|-------------|-------------|-----------|
| Between groups | 3 | 57.664 | 19.221 | .725 |
| Within groups | 44 | 1166.242 | 26.505 | p = .5424 |
| Total | 47 | 1223.906 | | |

Model II estimate of between component variance = -2.428.

| Diet ³ Treatments | Weeks | Mean ¹ | Std. Dev. | Std. Error |
|---------------------------------|-------|-------------------|-----------|------------|
| d1 = Chow | 12 | 23.343 | 5.096 | 1.471 |
| d2 = B90 | 12 | 26.011 | 5.184 | 1.496 |
| d3 = B60 | 12 | 23.641 | 4.518 | 1.304 |
| d4 = B30 | 12 | 23.489 | 5.724 | 1.653 |

| Comparison | Mean Diff. | Fisher PLSD ² | Scheffe F-test | Dunnnett t |
|------------|------------|--------------------------|----------------|------------|
| d1 vs. d2 | -2.668 | 4.236 | .537 | 1.269 |
| d1 vs. d3 | -.298 | 4.236 | .007 | .142 |
| d1 vs. d4 | -.146 | 4.236 | .002 | .07 |
| d2 vs. d3 | 2.37 | 4.236 | .424 | 1.127 |
| d2 vs. d4 | 2.521 | 4.236 | .48 | 1.2 |
| d3 vs. d4 | .152 | 4.236 | .002 | .072 |

¹ Weeks = 4 wks x 3 feeding periods; feeding periods = 0-30 (wks 1-4); 30-60 (wks 6-9); 60-90 (wks 10-13).

² Protected least squares difference.

³ Chow treatment received chow diet for all periods; B90 treatment received RFB diet for all periods; B60 treatment received chow diet until date 5-6 and RFB diet for the remaining periods; B30 treatment received chow diet until 6-6 and RFB diet for the remaining periods.

Table 13A. Overall ANOVA of daily feed consumption (g/rat/day) with no change in diet (Chow vs RFB)

One Factor ANOVA $X_i:TRTS$ $Y_i:f/d$

Analysis of Variance Table

| Source | DF | Sum Squares | Mean Square | F-test |
|----------------|----|-------------|-------------|-----------|
| Between groups | 1 | 42.696 | 42.696 | 1.616 |
| Within groups | 22 | 581.258 | 26.421 | p = .2169 |
| Total | 23 | 623.954 | | |

Model II estimate of between component variance = 16.275.

| Diet ³ Treatments | Weeks | Mean ¹ | Std. Dev. | Std. Error |
|---------------------------------|-------|-------------------|-----------|------------|
| Chow | 12 | 23.343 | 5.096 | 1.471 |
| B90 | 12 | 26.011 | 5.184 | 1.496 |

| Comparison | Mean Diff. | Fisher PLSD ² | Scheffe F-test | Dunnnett t |
|--------------|------------|--------------------------|----------------|------------|
| Chow vs. B90 | -2.668 | 2.649 | 1.616 | 1.271 |

¹ Weeks = 4 wks x 3 feeding periods; feeding periods = 0-30 (wks 1-4); 30-60 (wks 6-9); 60-90 (wks 10-13).

² Protected least squares difference.

³ Chow treatment received chow diet for all periods; B90 treatment received RFB diet for all periods; B60 treatment received chow diet until date 5-6 and RFB diet for the remaining periods; B30 treatment received chow diet until 6-6 and RFB diet for the remaining periods.

Table 14A. Average daily feed consumption (g/rat/day) of rats fed chow or RFB diets for different time periods.¹

| Weekly Period | Date | Diet Treatments ² | | | |
|---------------|------|------------------------------|-------------------------|-------------------------|-------------------------|
| | | Chow | B90 | B60 | B30* |
| 0 | 4-4 | — | — | — | — |
| 1 | 4-11 | 18.05±0.38 | 20.58±0.46 ^a | 17.98±0.32 | 18.30±0.43 |
| 2 | 4-18 | 19.88±.36 | 23.16±.55 ^a | 19.03±.52 | 19.43±.43 |
| 3 | 4-25 | 19.85±.24 | 23.98±.41 ^a | 19.72±.47 | 20.17±.85 |
| 4 | 5-2 | 18.38±.40 | 22.30±.54 ^a | 19.35±.82 | 19.28±1.69 |
| 5 | 5-9 | 17.50±0.80 | 25.4±0.74 ^a | 17.10±1.0 | 18.73±.04 |
| 6 | 5-16 | 31.30±1.07 | 34.84±1.72 | 34.10±0.5 | 30.95±1.27 |
| 7 | 5-23 | 23.31±0.55 ^a | 32.3±1.27 ^b | 32.60±0.86 ^b | 23.15±1.44 ^a |
| 8 | 5-31 | 22.76±0.63 | 21.05±1.51 | 24.78±1.54 | 20.72±0.71 |
| 9 | 6-6 | 15.75±1.28 ^a | 23.18±3.63 ^b | 23.1±1.74 ^b | 14.03±0.90 ^a |
| 10 | 6-13 | 29.92±1.08 ^a | 34.35±1.28 | 33.13±1.30 | 31.87±2.76 |
| 11 | 6-20 | 25.34±0.97 | 21.98±1.20 | 26.61±0.81 | 29.50±3.37 |
| 12 | 6-27 | 28.34±0.29 | 27.59±1.10 | 28.50±0.45 | 26.25±0.73 |
| 13 | 7-5 | 27.25±0.30 | 26.91±1.05 | 27.0±0.65 | 27.95±0.54 |

* Mean and standard error. Values with different superscripts differ significantly ($p < .05$) within period.

¹ See Table 1 for diets.

² Chow treatment received chow diet for all periods; B90 treatment received RFB diet for all periods; B60 treatment received chow diet until date 5-6 and RFB diet for the remaining periods; B30 treatment received chow diet until 6-6 and RFB diet for the remaining periods.

Table 14B. Mean daily feed consumption (g)/mean daily body weight (g) of rats fed chow or RFB for different time periods.¹

| Weekly Period | Date | Diet Treatments ² | | | |
|---------------|------|------------------------------|------------------------|------------------------|------------------------|
| | | Chow | B90 | B60 | B30* |
| 0 | 4-4 | — | — | — | — |
| 1 | 4-11 | .145±.003 | .167±.003 ^a | .145±.003 | .150±.003 |
| 2 | 4-18 | .115±.020 | .136±.003 ^a | .108±.003 | .112±.002 |
| 3 | 4-25 | .086±.002 | .105±.002 ^a | .090±0.00 | .090±.003 |
| 4 | 5-2 | .067±.002 | .084±.002 ^a | .070±.003 | .070±.005 |
| 5 | 5-9 | .058±.002 | .081±.002 ^a | .055±.003 | .060±.000 |
| 6 | 5-16 | .095±.004 | .104±.004 | .068±.010 ^a | .090±.004 |
| 7 | 5-23 | .065±.002 | .090±.004 ^a | .058±.010 | .065±.003 |
| 8 | 5-31 | .060±.002 | .056±.004 | .065±.003 ^a | .053±.002 |
| 9 | 6-6 | .040±.003 ^a | .057±.009 ^b | .057±.006 ^b | .035±.002 ^a |
| 10 | 6-13 | .078±.004 | .084±.003 | .078±.005 | .080±.007 |
| 11 | 6-20 | .061±.002 | .054±.004 | .062±.003 | .070±.007 |
| 12 | 6-27 | .067±.002 | .065±.003 | .062±.002 | .060±.000 |
| 13 | 7-5 | .065±.002 ^a | .060±.002 | .060±.000 | .062±.002 |

* Mean and standard error. Values with different superscripts differ significantly ($p < .05$) within period.

¹ See Table 1 for diets.

² Chow treatment received chow diet for all periods; B90 treatment received RFB diet for all periods; B60 treatment received chow diet until date 5-6 and RFB diet for the remaining periods; B30 treatment received chow diet until 6-6 and RFB diet for the remaining periods.

Table 15. Average daily gain/average daily feed consumption (g/g) of rats fed chow or RFB for different time periods.¹

| Weekly Period | Date | Diet Treatments ² | | | |
|---------------|------|------------------------------|-----------------------|-----------------------|-----------------------|
| | | Chow | B90 | B60 | B30* |
| 0 | 4-4 | — | — | — | — |
| 1 | 4-11 | .37±.008 | .31±.006 ^a | .37±.010 | .36±.002 |
| 2 | 4-18 | .36±.008 | .32±.008 ^a | .37±.009 | .37±.004 |
| 3 | 4-25 | .36±.007 | .31±.005 ^a | .37±.009 | .36±.004 |
| 4 | 5-2 | .36±.007 | .31±.006 ^a | .38±.015 | .36±.005 |
| 5 | 5-9 | .30±.022 | .23±.013 ^a | .30±.020 | .29±.011 |
| 6 | 5-16 | .12±.003 | .11±.005 | .18±.028 ^a | .13±.004 |
| 7 | 5-23 | .13±.003 | .11±.004 | .19±.028 ^a | .13±.003 |
| 8 | 5-31 | .15±.004 ^a | .12±.004 ^b | .12±.008 ^b | .14±.004 ^a |
| 9 | 6-6 | .09±.024 | .08±.018 | .10±.017 | .10±.019 |
| 10 | 6-13 | .09±.003 | .09±.009 | .09±.005 | .06±.021 |
| 11 | 6-20 | .07±.002 | .05±.024 | .08±.004 | .09±.013 |
| 12 | 6-27 | .05±.006 | .07±.028 | .07±.003 | .06±.019 |
| 13 | 7-5 | .04±.007 | .004±.025 | .02±.018 | .04±.003 |

* Mean and standard error. Values with different superscripts differ significantly ($p < .05$) within period.

¹ See Table 1 for diets.

² Chow treatment received chow diet for all periods; B90 treatment received RFB diet for all periods; B60 treatment received chow diet until date 5-6 and RFB diet for the remaining periods; B30 treatment received chow diet until 6-6 and RFB diet for the remaining periods.

Table 16. Average daily water consumption (ml/rat/day) of rats fed chow or RFB for different time periods.¹

| Weekly Period | Date | Diet Treatments ² | | | |
|---------------|------|------------------------------|-----------------------|------------------------|-----------------------|
| | | Chow | B90 | B60 | B30* |
| 0 | 4-4 | — | — | — | — |
| 1 | 4-11 | 21.8±.27 | 17.3±.50 ^a | 21.6±0.90 | 23.5±1.1 |
| 2 | 4-18 | 26.2±.63 | 20.6±.32 ^a | 25.7±.19 | 26.3±.51 |
| 3 | 4-25 | 29.9±.45 | 24.3±.36 ^a | 29.3±.66 | 29.8±.61 |
| 4 | 5-2 | 33.2±.97 | 27.8±.70 ^a | 33.0±1.2 | 32.2±.72 |
| 5 | 5-9 | 34.9±.60 | 32.3±.87 ^a | 37.2±1.1 | 37.6±.58 |
| 6 | 5-16 | 39.1±.47 ^b | 31.5±1.6 ^a | 32.5±4.6 ^{ab} | 38.3±1.2 ^b |
| 7 | 5-23 | 34.1±.67 ^b | 27.5±1.3 ^a | 31.2±2.6 ^{ab} | 33.1±.97 ^b |
| 8 | 5-31 | 31.5±.92 ^a | 24.2±1.1 ^b | 25.6±2.7 ^b | 31.8±1.1 ^a |
| 9 | 6-6 | 26.9±1.0 | 20.3±1.2 ^a | 22.5±1.8 | 26.2±1.1 |
| 10 | 6-13 | 35.8±.56 ^a | 25.0±1.5 | 23.9±1.5 | 24.5±1.8 |
| 11 | 6-20 | 30.3±.90 ^a | 23.0±1.3 | 22.9±1.7 | 23.9±.90 |
| 12 | 6-27 | 32.4±.53 ^a | 22.2±1.7 | 23.2±.90 | 26.1±1.3 |
| 13 | 7-5 | 28.9±.76 ^a | 22.8±2.2 | 22.2±1.8 | 24.7±2.2 |

* Mean and standard error. Values with different superscripts differ significantly ($p < .05$) within period.

¹ See Table 1 for diets.

² Chow treatment received chow diet for all periods; B90 treatment received RFB diet for all periods; B60 treatment received chow diet until date 5-6 and RFB diet for the remaining periods; B30 treatment received chow diet until 6-6 and RFB diet for the remaining periods.

Table 17. Average daily water consumption (ml/rat/day) analyzed overall feeding periods.

One Factor ANOVA X_1 :TRTS Y_1 :W(ml)

Analysis of Variance Table

| Source | DF | Sum Squares | Mean Square | F-test |
|----------------|----|-------------|-------------|---------|
| Between groups | 3 | 310.757 | 103.586 | 5.137 |
| Within groups | 44 | 887.265 | 20.165 | p=.0039 |
| Total | 47 | 1198.023 | | |

Model II estimate of between component variance = 27.807.

| Diet | Weeks ¹ | Mean | Std. Dev. | Std. Error |
|---------|--------------------|--------|-----------|------------|
| d1=Chow | 12 | 30.833 | 4.631 | 1.337 |
| d2=B90 | 12 | 23.878 | 3.813 | 1.101 |
| d3=B60 | 12 | 26.511 | 4.837 | 1.396 |
| d4=B30 | 12 | 28.356 | 4.613 | 1.332 |

| Comparison | Mean Diff. | Fisher PLSD ² | Scheffe F-test | Dunnnett t |
|------------|------------|--------------------------|----------------|------------|
| d1 vs. d2 | 6.955 | 3.695* | 4.798* | 3.794 |
| d1 vs. d3 | 4.322 | 3.695* | 1.853 | 2.358 |
| d1 vs. d4 | 2.478 | 3.695 | .609 | 1.352 |
| d2 vs. d3 | -2.633 | 3.695 | .688 | 1.436 |
| d2 vs. d4 | -4.478 | 3.695* | 1.988 | 2.442 |
| d3 vs. d4 | -1.844 | 3.695 | .337 | 1.006 |

* Significant at 95%.

¹ Weeks = 4 wks x 3 feeding periods; feeding periods = 0-30 (wks 1-4); 30-60 (wks 6-9) and 60-90 (wks 10-13).

² Protected least squares difference.

Table 18. Fecal and waste production by rats fed chow or RFB diets for different time periods.

| Week | Diet* | Rats | Total Body Wt. (g) | Period (days) | Fecal Vol. (ml) | ml/g of rat/day | Total Fecal Wt. (g) | g feces/g of rat/day |
|------|-------|------|--------------------|---------------|-----------------|-----------------|---------------------|----------------------|
| 1 | RFB | 64 | 7809.0 | 4 | 415.0 | .0133 | 215.0 | .0069 |
| 1 | CHOW | 160 | 19925.0 | 4 | 2964.0 | .0372 | 1339.0 | .0168 |
| 2 | RFB | 64 | 10988.0 | 7 | 1034.0 | .0134 | 537.0 | .0070 |
| 2 | CHOW | 160 | 27845.0 | 7 | 10546.0 | .0541 | 4766.0 | .0245 |
| 3 | RFB | 64 | 14294.0 | 7 | 1319.0 | .0132 | 685.0 | .0068 |
| 3 | CHOW | 160 | 35974.0 | 7 | 13675.0 | .0543 | 6180.0 | .0245 |
| 4 | RFB | 64 | 17368.0 | 7 | 1655.0 | .0136 | 859.0 | .0070 |
| 4 | CHOW | 160 | 43687.0 | 7 | 18111.0 | .0592 | 8186.0 | .0268 |
| 5 | RFB | 60 | 18668.0 | 7 | 1748.0 | .0134 | 907.0 | .0069 |
| 5 | CHOW | 108 | 33378.0 | 7 | 19297.0 | .0826 | 8722.0 | .0373 |
| 6 | RFB | 60 | 20222.0 | 7 | 1780.0 | .0126 | 924.0 | .0065 |
| 6 | CHOW | 108 | 36327.0 | 7 | 12804.0 | .0504 | 5787.0 | .0228 |
| 7 | RFB | 60 | 21295.0 | 7 | 1884.0 | .0126 | 978.0 | .0066 |
| 7 | CHOW | 108 | 38674.0 | 7 | 12168.0 | .0450 | 5500.0 | .0203 |
| 8 | RFB | 84 | 31629.0 | 8 | 4426.0 | .0175 | 2240.0 | .0088 |
| 8 | CHOW | 84 | 31819.0 | 8 | 10097.0 | .0397 | 4792.0 | .0188 |
| 9 | RFB | 56 | 22228.0 | 6 | 971.3 | .0073 | 491.0 | .0037 |
| 9 | CHOW | 56 | 21808.0 | 6 | 3698.0 | .0283 | 1755.0 | .0134 |
| 10 | RFB | 80 | 32934.0 | 7 | 2628.0 | .0114 | 1330.0 | .0057 |
| 10 | CHOW | 32 | 12906.0 | 7 | 3566.0 | .0395 | 1692.0 | .0187 |
| 11 | RFB | 80 | 34020.0 | 7 | 2809.0 | .0118 | 1456.0 | .0061 |
| 11 | CHOW | 32 | 13317.0 | 7 | 4182.0 | .0449 | 2081.0 | .0223 |
| 12 | RFB | 80 | 35127.0 | 7 | 2755.0 | .0112 | 1428.0 | .0058 |
| 12 | CHOW | 32 | 13650.0 | 7 | 3782.0 | .0396 | 1882.0 | .0197 |
| 13 | RFB | 80 | 35480.0 | 8 | 2882.0 | .0102 | 1494.0 | .0053 |
| 13 | CHOW | 32 | 13886.0 | 8 | 4044.0 | .0364 | 2012.0 | .0181 |

* See Table 1 for diet information.

¹ Feces was collected for treatment groups on a weekly basis; therefore variance terms were not associated with weekly values. Error terms associated with these variables are shown in Table S-2 of the attached supplemental report.

Table 19. Metabolic measurements for all calorimetry periods.¹

| Variable ² | Calorimetry Period | Diet Treatments | | | | | | | |
|------------------------------|--------------------|-----------------|----------|----------|----------|----------|----------|----------|----------|
| | | Chow | | RFB90 | | RFB60 | | RFB30 | |
| | | Light | Dark | Light | Dark | Light | Dark | Light | Dark |
| Heat | 30 days | 6.56±.22 | 8.49±.22 | 6.66±.22 | 8.35±.24 | -- | -- | -- | -- |
| Production (HP) | 60 days | 6.82±.22 | 8.44±.22 | 6.88±.22 | 8.68±.22 | 6.97±.22 | 8.95±.22 | -- | -- |
| Kcal/hr/Kg | 90 days | 5.66±.22 | 7.23±.22 | 5.48±.22 | 7.29±.22 | 5.56±.22 | 7.44±.22 | 5.76±.22 | 7.53±.22 |
| CO ₂ ³ | 30 days | 1.13±.04 | 1.49±.04 | 1.13±.04 | 1.46±.04 | -- | -- | -- | -- |
| Production | 60 days | 1.24±.04 | 1.48±.04 | 1.27±.04 | 1.55±.04 | 1.28±.04 | 1.57±.04 | -- | -- |
| L/hr/Kg | 90 days | 1.13±.04 | 1.41±.04 | 1.17±.04 | 1.43±.04 | 1.12±.04 | 1.46±.04 | 1.17±.04 | 1.46±.04 |
| O ₂ ³ | 30 days | 1.35±.05 | 1.74±.05 | 1.38±.05 | 1.72±.06 | -- | -- | -- | -- |
| Consumption | 60 days | 1.39±.05 | 1.74±.05 | 1.39±.05 | 1.77±.05 | 1.41±.05 | 1.84±.05 | -- | -- |
| L/hr/Kg | 90 days | 1.12±.05 | 1.45±.05 | 1.08±.05 | 1.45±.05 | 1.10±.05 | 1.42±.05 | 1.13±.05 | 1.50±.05 |
| RQ | 30 days | .84±.02 | .85±.02 | .82±.02 | .85±.02 | -- | -- | -- | -- |
| | 60 days | .90±.02 | .86±.02 | .91±.02 | .88±.02 | .91±.02 | .86±.02 | -- | -- |
| | 90 days | 1.01±.02 | .97±.02 | 1.03±.02 | .98±.02 | 1.02±.02 | .99±.02 | 1.03±.02 | .98±.02 |
| Metabolic Water | 30 days | 0.722 | 0.934 | 0.733 | 0.919 | -- | -- | -- | -- |
| g H ₂ O/hr/Kg | 60 days | 0.750 | 0.928 | 0.757 | 0.955 | 0.767 | 0.985 | -- | -- |
| | 90 days | 0.623 | 0.795 | 0.603 | 0.802 | 0.612 | 0.818 | 0.634 | 0.828 |

¹ n = 6 cages from each diet treatment measured over a 24-hr period. Mean and standard error of the mean values represent six cages sampled at 30-min intervals for 12 h of light and 12 h of dark.

² HP was different (p < .05) between light vs. dark. CO₂ was different (p < .05) between light vs. dark. O₂ was different (p < .05) between light vs. dark. RQ was not different. Water was estimated from HP as 0.11 g H₂O/Kcal and assuming mixed nutrients being metabolized.

³ For conversions between volumetric and gravimetric values, see page 9 of this report.

Table 20. Moisture production during 60-day calorimetry period.

| Calorimetry Date | Diet Treatments | | | |
|---------------------|-----------------|-----------------------------|-------------|------------------------------|
| | Chow | | RFB | |
| | Calorimeter | g H ₂ O/hr/kg BW | Calorimeter | g H ₂ O/hr/kg BW* |
| 6/1/94 | #1 | 4.41 | #2 | 6.02 |
| | | | #3 | 4.10 |
| 6/2/94 | #2 | 3.37 | #1 | 3.41 |
| | | | #3 | 3.56 |
| 6/3/94 | #3 | 5.29 | #1 | 3.74 |
| | | | #2 | 3.39 |
| 6/4/94 | #1 | 4.11 | #2 | 4.09 |
| | | | #3 | 4.95 |
| 6/5/94 | #2 | 3.56 | #1 | 3.08 |
| | | | #3 | 3.70 |
| Mean±SEM | | 4.15±0.34 | 4.00±0.39 | |

* g/hr per kilogram of rat body weight in cage.
No effect of diet or calorimeter on moisture production.

Table 21. Moisture production during 90-day calorimetry period.

| Calorimetry Date | Diet Treatments | | | |
|------------------|-----------------|-----------------------------|-------------|------------------------------|
| | Chow | | RFB | |
| | Calorimeter | g H ₂ O/hr/kg BW | Calorimeter | g H ₂ O/hr/kg BW* |
| 6/30/94 | #1 | 4.68 | #2 | 4.84 |
| | | | #3 | 3.96 |
| 7/1/94 | #2 | 4.36 | #1 | 4.72 |
| | | | #3 | 4.43 |
| 7/2/94 | #3 | 6.84 | #1 | 4.34 |
| | | | #2 | 3.75 |
| 7/3/94 | | | #1 | 4.37 |
| | | | #2 | 3.78 |
| | | | #3 | 3.79 |
| 7/4/94 | #1 | 5.02 | #2 | 4.26 |
| | | | #3 | 3.88 |
| 7/5/94 | #2 | 4.92 | #1 | 7.02 |
| | | | #3 | 3.82 |
| 7/6/94 | #3 | 4.38 | #1 | 5.67 |
| | | | #2 | 4.22 |
| 7/7/94 | | | #1 | 5.37 |
| | | | #2 | 4.44 |
| | | | #3 | 3.81 |
| Mean±SEM | | 5.03±0.37 | | 4.47±20 |

* g/hr per kilogram of rat body weight in cage.
 No effect of diet or calorimeter on moisture production.

Table 22. Weights (g) of gastrointestinal tracts with contents.*

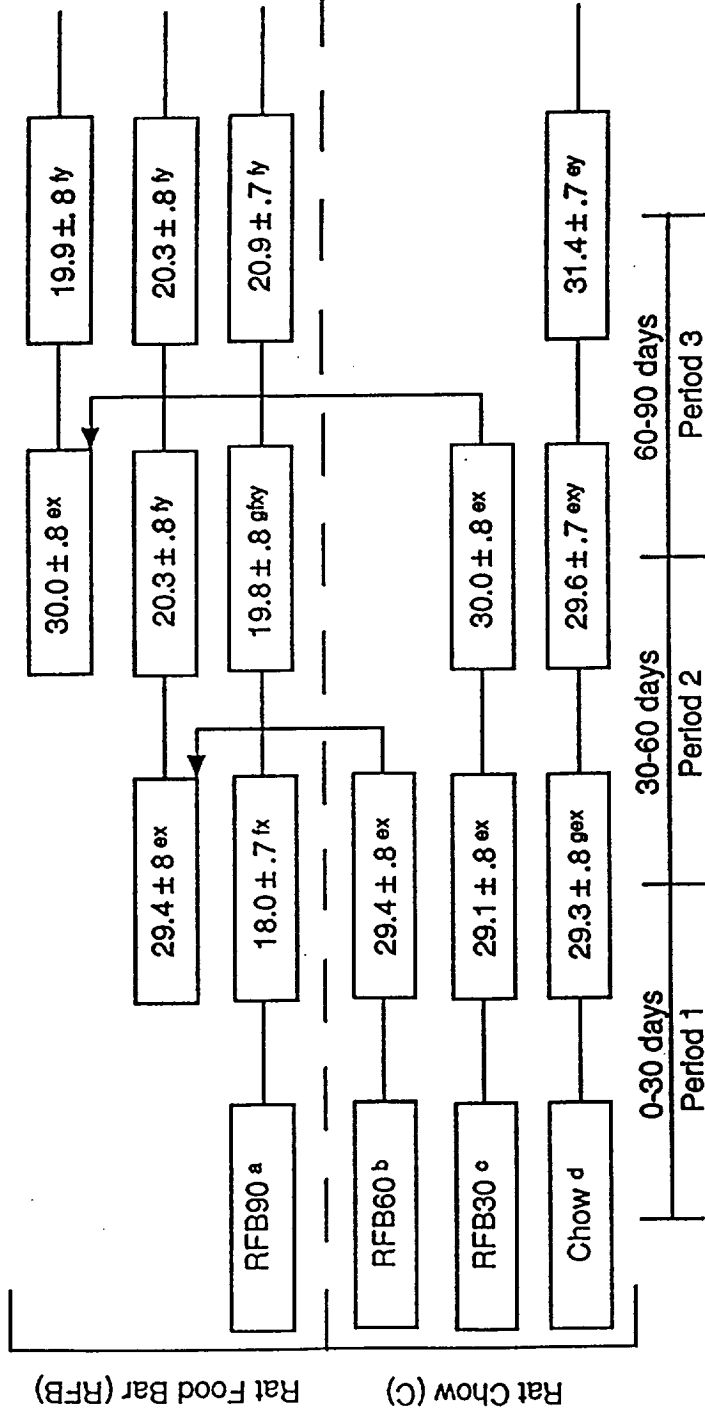

* Least-squares means ± SE of 16 rats for Chow and RFB90; n=12 for RFB60 and RFB30.

^g Least-squares means ± SE of 14 rats.

^{e-f} Means in a column with no common superscripts differ (p<.05).

^{x-y} Means in a row with no common superscripts differ (p<.05).

^a Received rat food bar for all three periods.

^b Switched from rat chow to rat food bar following period 1.

^c Switched from rat chow to rat food bar following period 2.

^d Received rat chow for all three periods.

Table 23. Weights (g) of gastrointestinal tracts without contents.*

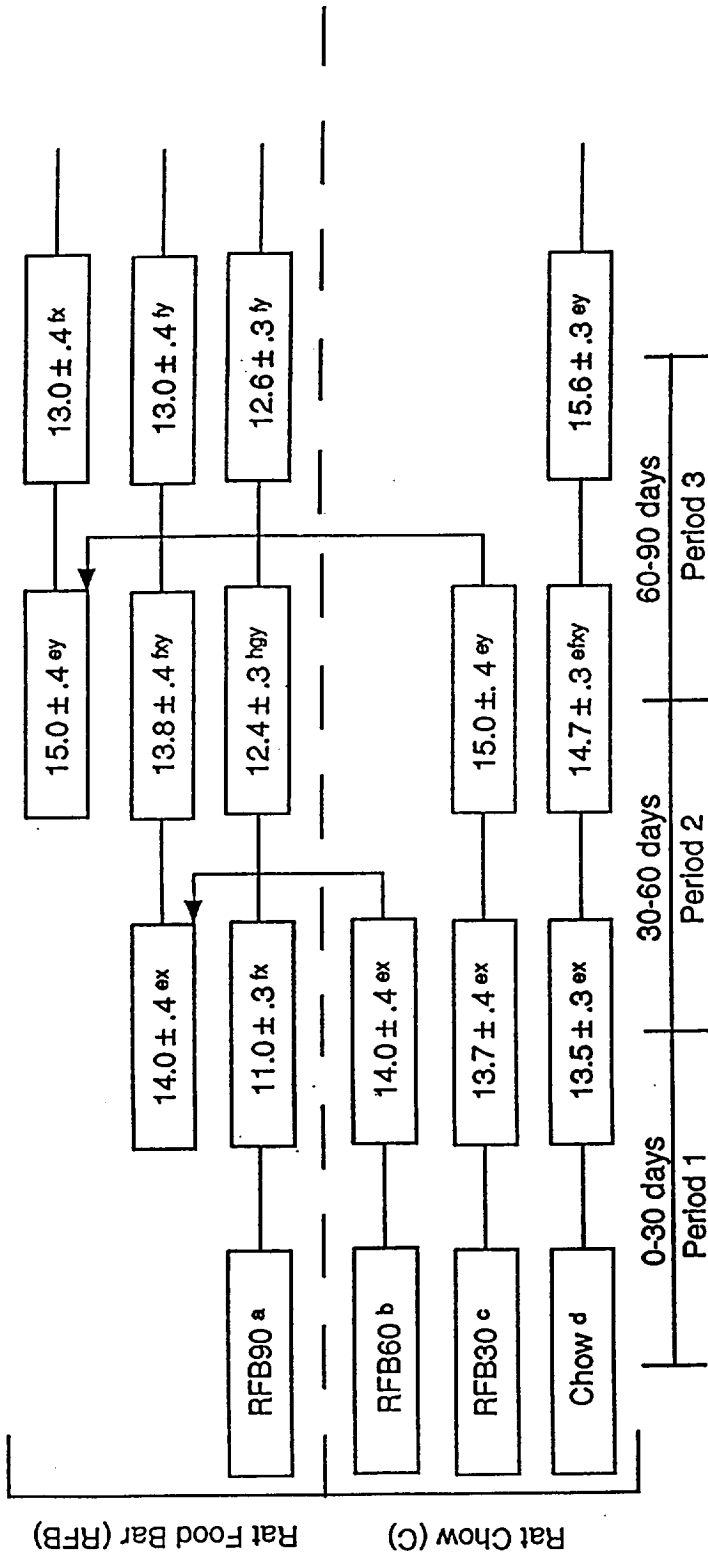

* Least-squares means ± SE of 16 rats for chow and RFB90; n=12 for RFB60 and RFB30.

h Least-squares mean ± SE of 14 rats.

e-g Means in a column with no common superscripts differ (p<.05).

x-y Means in a row with no common superscripts differ (p<.05).

a Received rat food bar for all three periods.

b Switched from rat chow to rat food bar following period 1.

c Switched from rat chow to rat food bar following period 2.

d Received rat chow for all three periods.

Table 24. Lengths (cm) of gastrointestinal tracts.*

| Group | Rat Food Bar (RFB) | | | Rat Chow (C) | | |
|--------------------|----------------------------|----------------------------|----------------------------|----------------------------|---------------------------|----------------------------|
| | 0-30 days | 30-60 days | 60-90 days | 0-30 days | 30-60 days | 60-90 days |
| RFB90 ^a | 143.0 ± 2.3 ^e | 145.3 ± 2.3 ^{ey} | 140.5 ± 2.3 ^{fy} | 143.0 ± 2.3 ^e | 137.9 ± 2.3 ^l | 139.2 ± 2.3 ^{lg} |
| RFB60 ^b | 126.2 ± 2.0 ^{gx} | 133.1 ± 2.0 ^{hly} | 132.8 ± 2.0 ^{gy} | 143.0 ± 2.3 ^e | 145.3 ± 2.3 ^{ey} | 146.8 ± 2.0 ^{hey} |
| RFB30 ^c | 136.7 ± 2.3 ^{fx} | 145.3 ± 2.3 ^{ey} | | 137.4 ± 2.0 ^{eix} | 145.0 ± 2.0 ^{ey} | |
| Chow ^d | 137.4 ± 2.0 ^{eix} | 145.0 ± 2.0 ^{ey} | 146.8 ± 2.0 ^{hey} | | | |

* Least-squares means ± SE of 16 rats for Chow and RFB90; n=12 for RFB60 and RFB30.

^h Least-squares means ± SE of 15 rats.

^{e-g} Means in a column with no common superscripts differ (p<.05).

^{x-y} Means in a row with no common superscripts differ (p<.05).

^a Received rat food bar for all three periods.

^b Switched from rat chow to rat food bar following period 1.

^c Switched from rat chow to rat food bar following period 2.

^d Received rat chow for all three periods.

Table 25. Numbers of Peyer's patches in the gastrointestinal tract.*

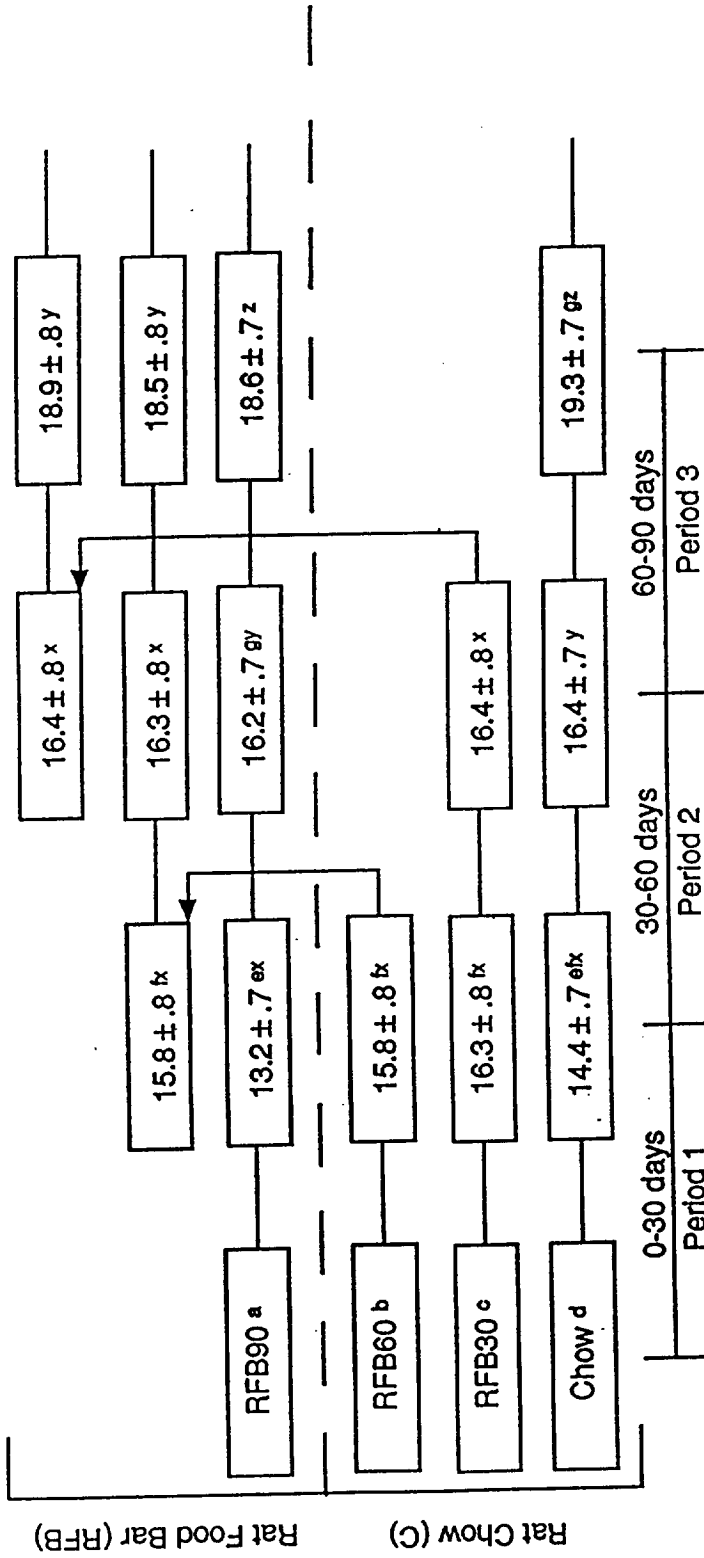

* Least-squares means ± SE of 16 rats for Chow and RFB90; n=12 for RFB60 and RFB30.

^a Least-squares means ± SE of 15 rats.

^{e-f} Means in a column with no common superscripts differ (p<.05).

^{x-z} Means in a row with no common superscripts differ (p<.05).

^a Received rat food bar for all three periods.

^b Switched from rat chow to rat food bar following period 1.

^c Switched from rat chow to rat food bar following period 2.

^d Received rat chow for all three periods.

Table 26. Size of Peyer's patches of the duodenum (surface area, mm²/patch).

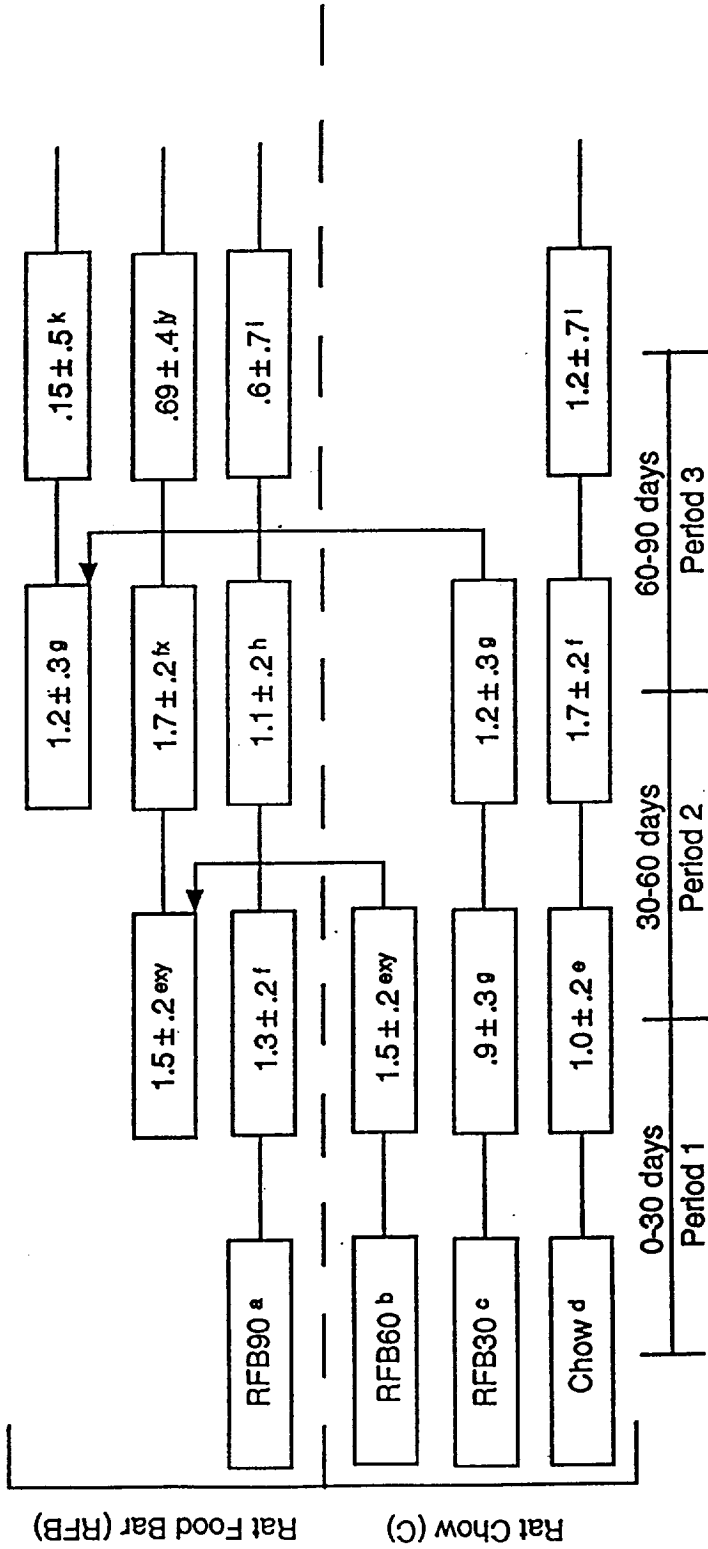

- ^e Least-squares means ± SE of 10 rats.
- ^f Least-squares means ± SE of 9 rats.
- ^g Least-squares means ± SE of 8 rats.
- ^h Least-squares mean ± SE of 13 rats.
- ⁱ Least-squares means ± SE of 1 rat.
- ^j Least-squares mean ± SE of 3 rats.
- ^k Least-squares mean ± SE of 2 rats.
- ^{x-y} Means in a row with no common superscripts differ (p < .05).

- ^a Received rat food bar for all three periods.
- ^b Switched from rat chow to rat food bar following period 1.
- ^c Switched from rat chow to rat food bar following period 2.
- ^d Received rat chow for all three periods.

Table 27. Size of Peyer's patches of the jejunum (surface area, mm²/patch).

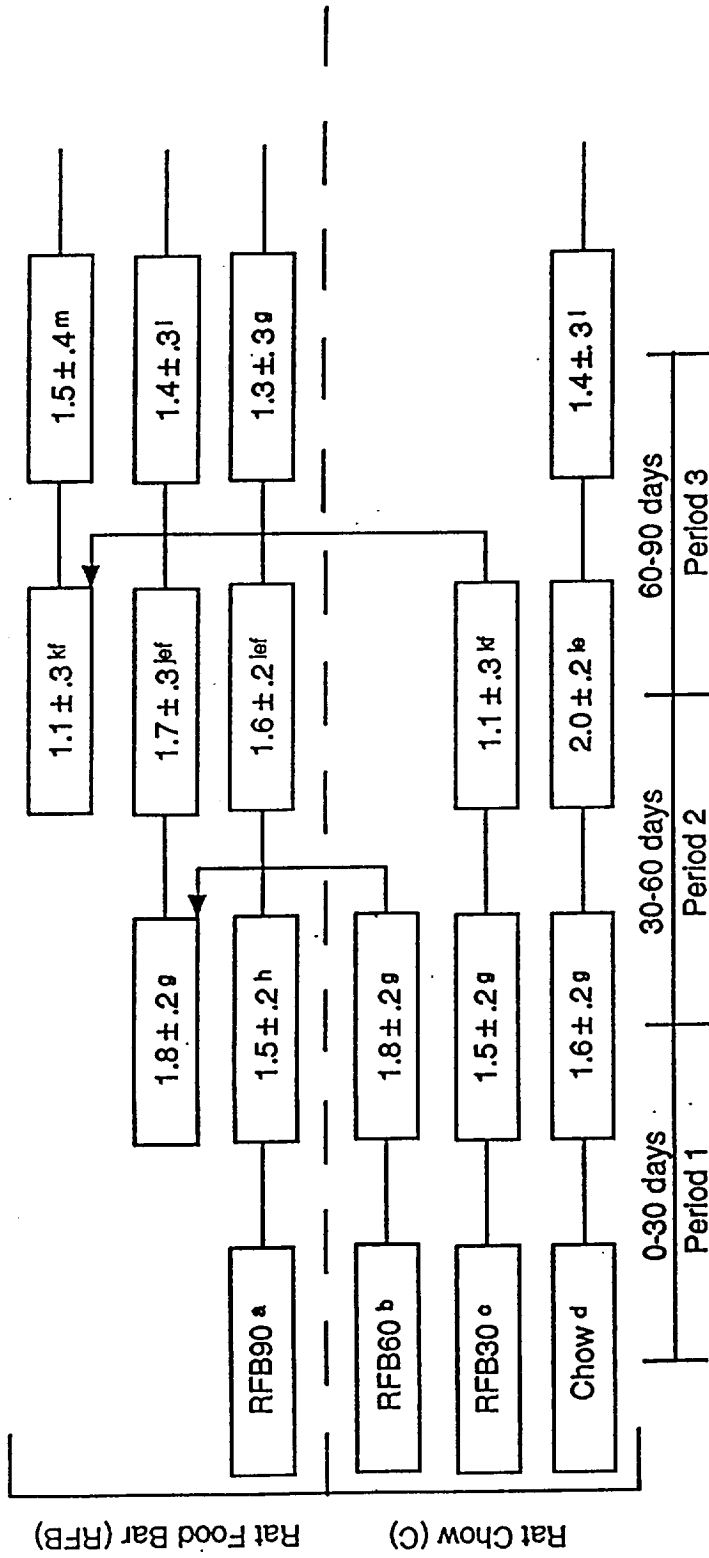

^g Least-squares means ± SE of 12 rats.

^h Least-squares mean ± SE of 14 rats.

ⁱ Least-squares means ± SE of 13 rats.

^j Least-squares mean ± SE of 11 rats.

^k Least-squares means ± SE of 10 rats.

^l Least-squares means ± SE of 8 rats.

^m Least-squares mean ± SE of 5 rats.

^{e-f} Means in a column with no common superscripts differ ($p < .05$).

^a Received rat food bar for all three periods.

^b Switched from rat chow to rat food bar following period 1.

^c Switched from rat chow to rat food bar following period 2.

^d Received rat chow for all three periods.

Table 28. Size of Peyer's patches of the ileum (surface area, mm²/patch).

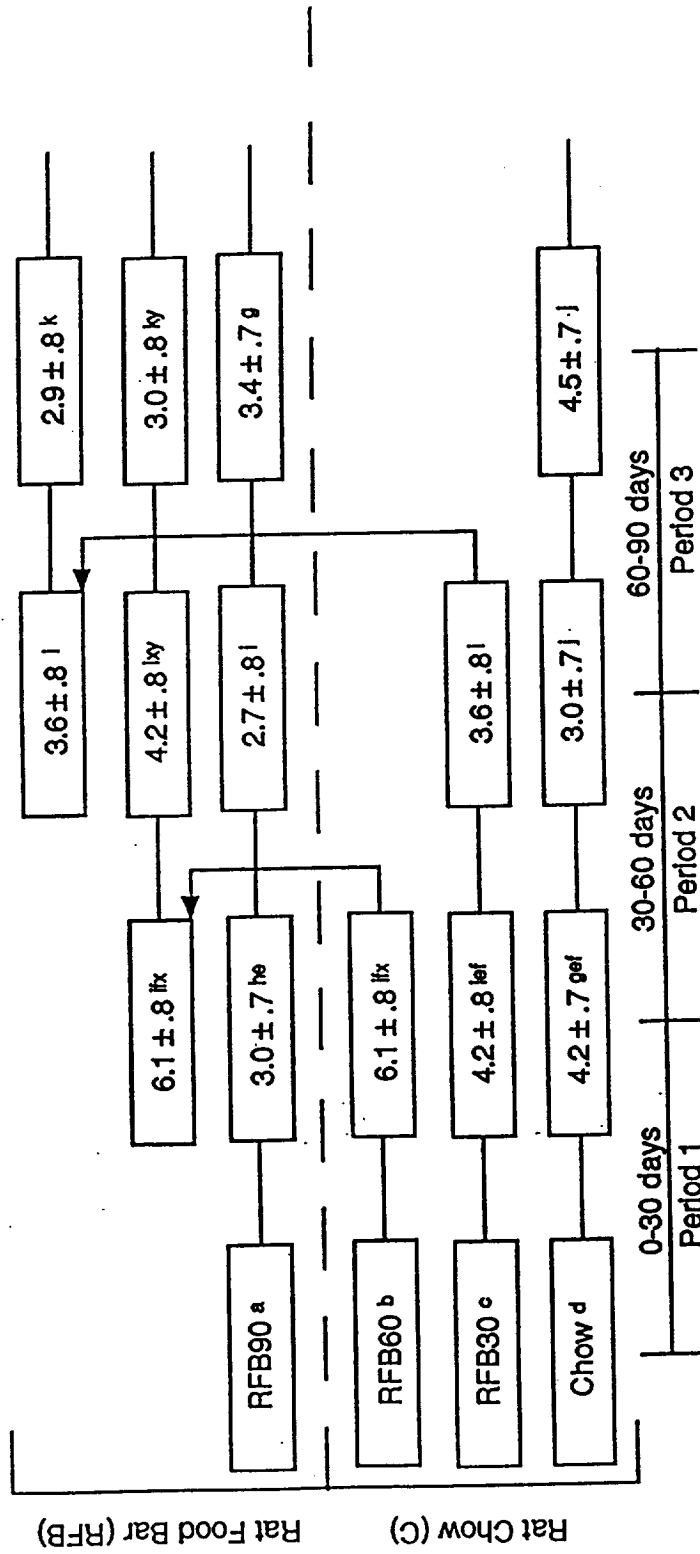

- g Least-squares means ± SE of 14 rats.
- h Least-squares mean ± SE of 16 rats.
- i Least-squares means ± SE of 12 rats.
- j Least-squares means ± SE of 13 rats.
- k Least-squares means ± SE of 11 rats.
- e-f Means in a column with no common superscripts differ ($p < .05$).
- x-y Means in a row with no common superscripts differ ($p < .05$).
- a Received rat food bar for all three periods.
- b Switched from rat chow to rat food bar following period 1.
- c Switched from rat chow to rat food bar following period 2.
- d Received rat chow for all three periods.

Table 29. Lymphocyte infiltration of duodenal Intestinal villi.*

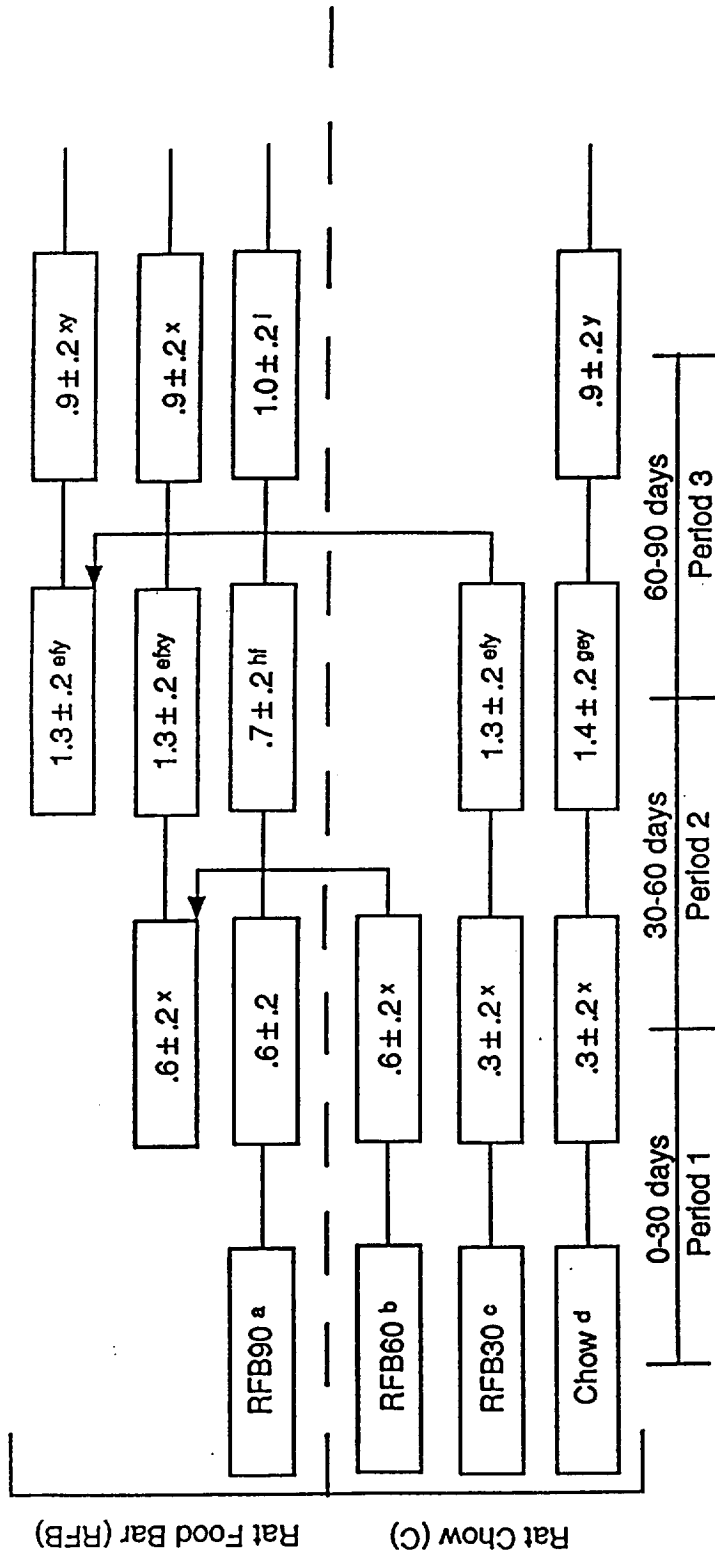

+ Least-squares means ± SE of 16 rats for Chow and RFB90; n=12 for RFB60 and RFB30.

† Scoring was: 0=essentially normal, 1=mild lymphocytic infiltration of intestinal villi, and 2=heavy lymphocytic infiltration of intestinal villi.

g Least-squares means ± SE of 15 rats.

h Least-squares means ± SE of 14 rats.

i Least-squares mean ± SE of 15 rats.

e-f Means in a column with no common superscripts differ (p<.05).

x-y Means in a row with no common superscripts differ (p<.05).

a Received rat food bar for all three periods.

b Switched from rat chow to rat food bar following period 1.

c Switched from rat chow to rat food bar following period 2.

d Received rat chow for all three periods.

Table 30. Lymphocyte Infiltration of jejunal intestinal villi.⁺

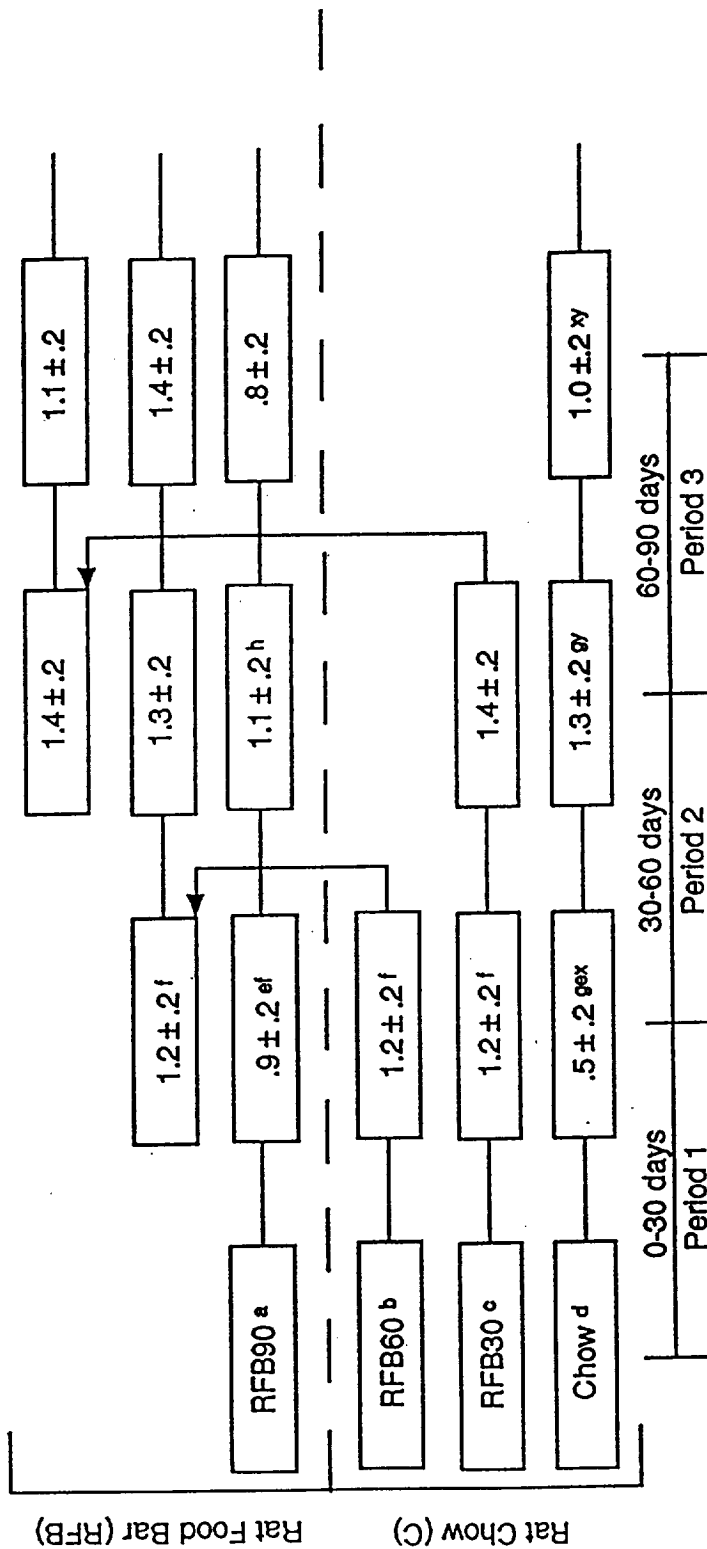

- + Least-squares means ± SE of 16 rats for Chow and RFB90; n=12 for RFB60 and RFB30.
- t Scoring was: 0=essentially normal, 1=mild lymphocytic infiltration of intestinal villi, and 2=heavy lymphocytic infiltration of intestinal villi.
- g Least-squares means ± SE of 15 rats.
- h Least-squares means ± SE of 14 rats.
- e-f Means in a column with no common superscripts differ (p<.05).
- xy Means in a row with no common superscripts differ (p<.05).
- a Received rat food bar for all three periods.
- b Switched from rat chow to rat food bar following period 1.
- c Switched from rat chow to rat food bar following period 2.
- d Received rat chow for all three periods.

Table 31. Lymphocyte Infiltration of ileal Intestinal villi.⁺

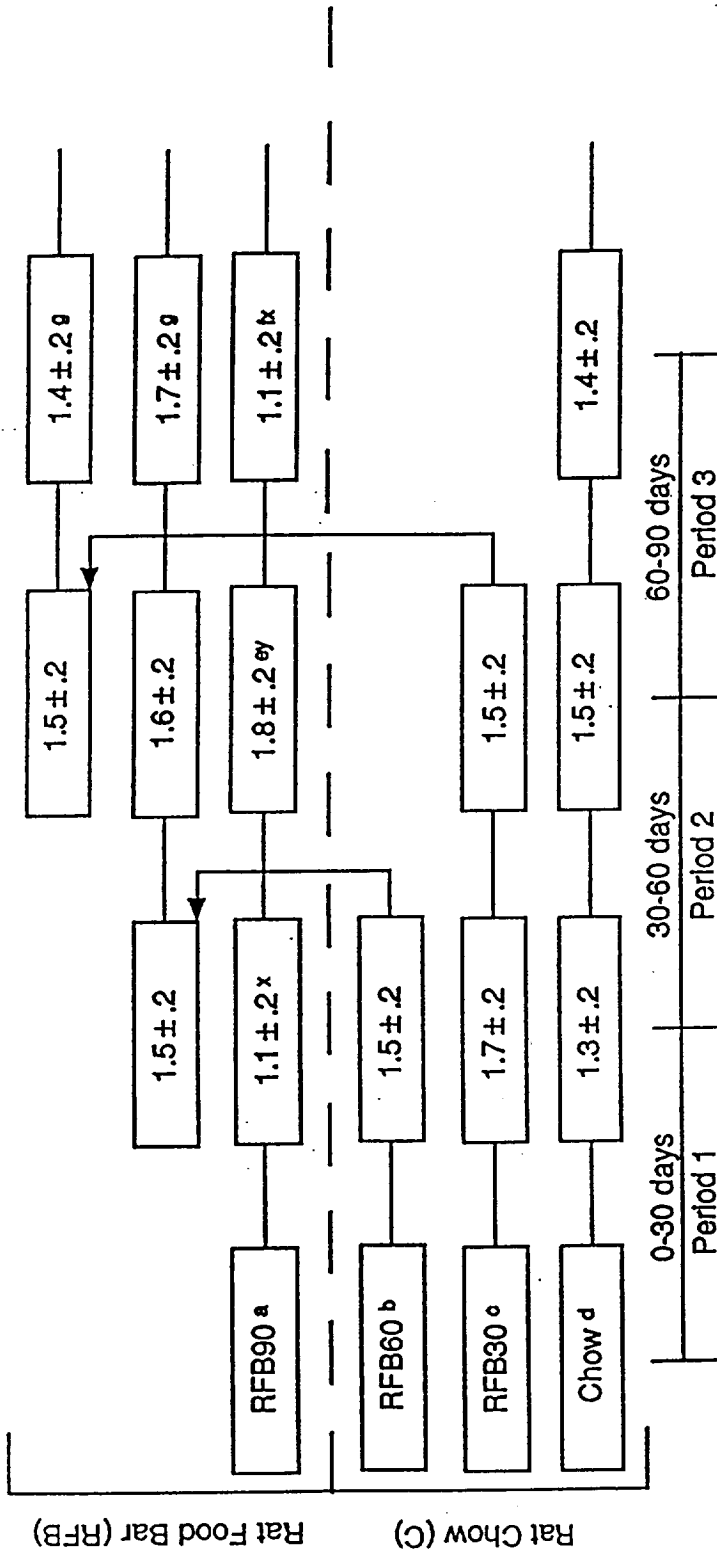

⁺ Least-squares means ± SE of 16 rats for Chow and RFB90; n=12 for RFB60 and RFB30.

[†] Scoring was: 0=essentially normal, 1=mild lymphocytic infiltration of intestinal villi, and 2=heavy lymphocytic infiltration of intestinal villi.

^e Least-squares means ± SE of 14 rats.

^f Least-squares mean ± SE of 15 rats.

^g Least-squares means ± SE of 11 rats.

^{x-y} Means in a row with no common superscripts differ (p<.05).

^a Received rat food bar for all three periods.

^b Switched from rat chow to rat food bar following period 1.

^c Switched from rat chow to rat food bar following period 2.

^d Received rat chow for all three periods.

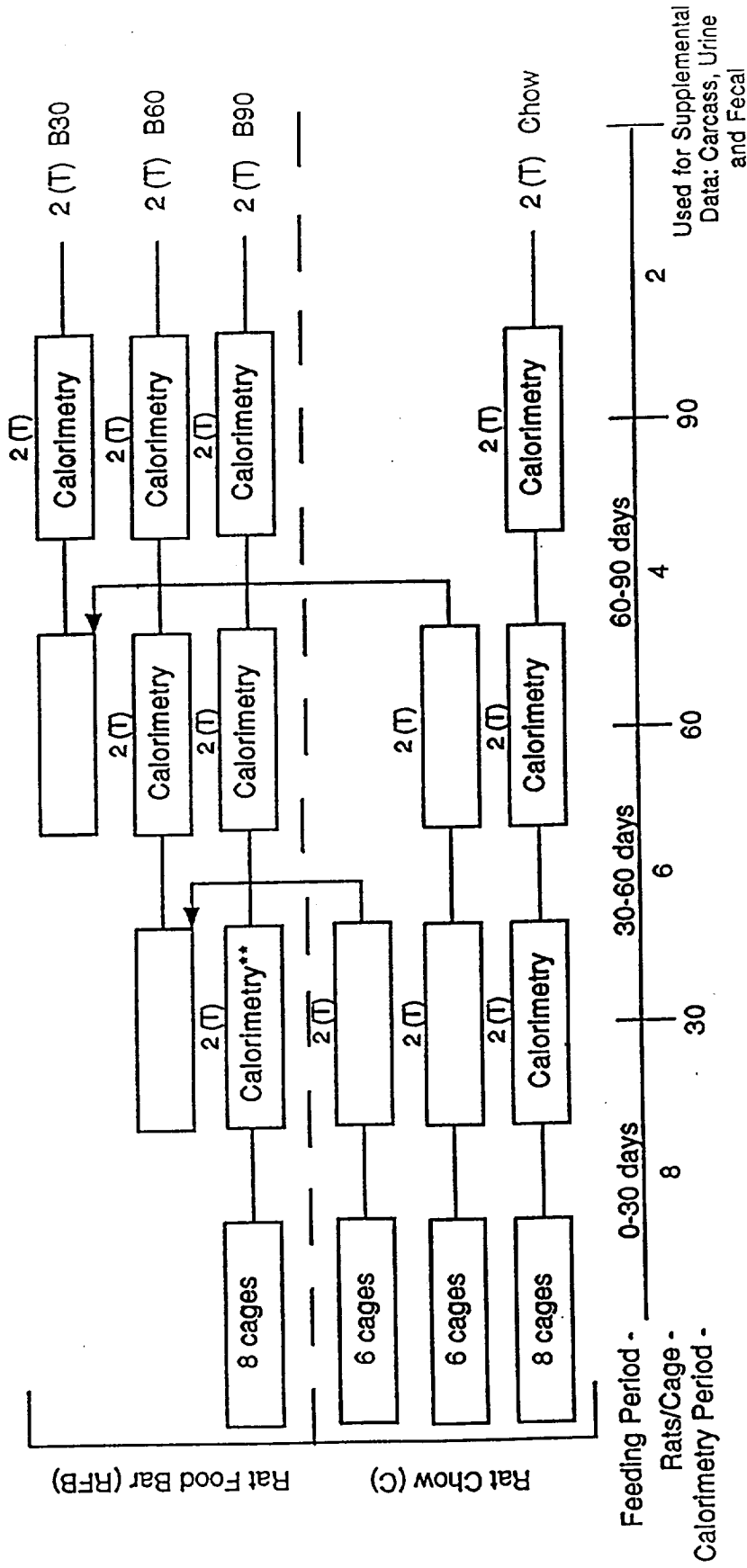

2 (T) = 2 rats removed from each cage for tissue analysis after calorimetry.
 ** = Calorimetry on 6 cages per treatment.

Diet Treatments:

- B30 = Rats on food bar for 30 days.
- B60 = Rats on food bar for 60 days.
- B90 = Rats on food bar for 90 days.
- Chow = Rat chow control for calorimetry at all weights and ages.

Figure 1. Experimental Design and General Protocol

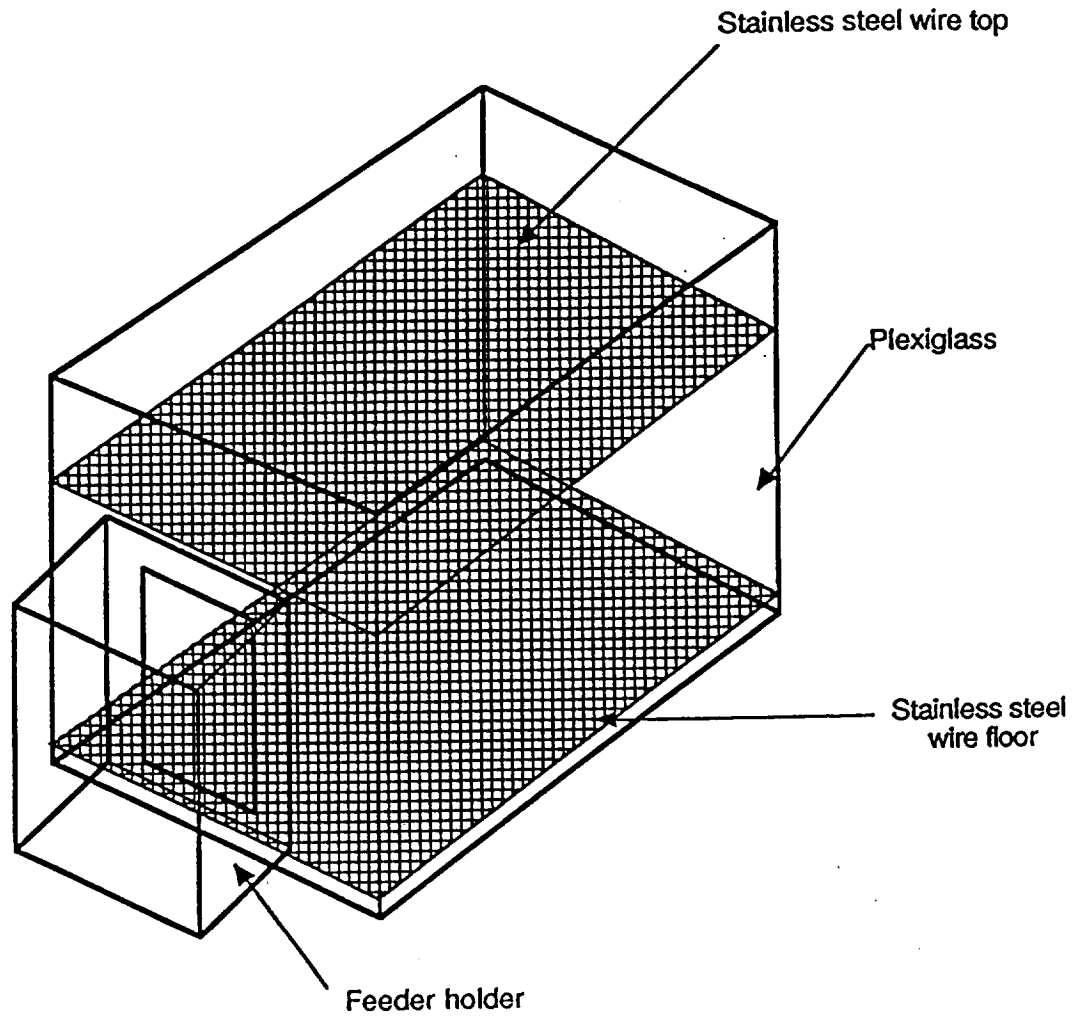
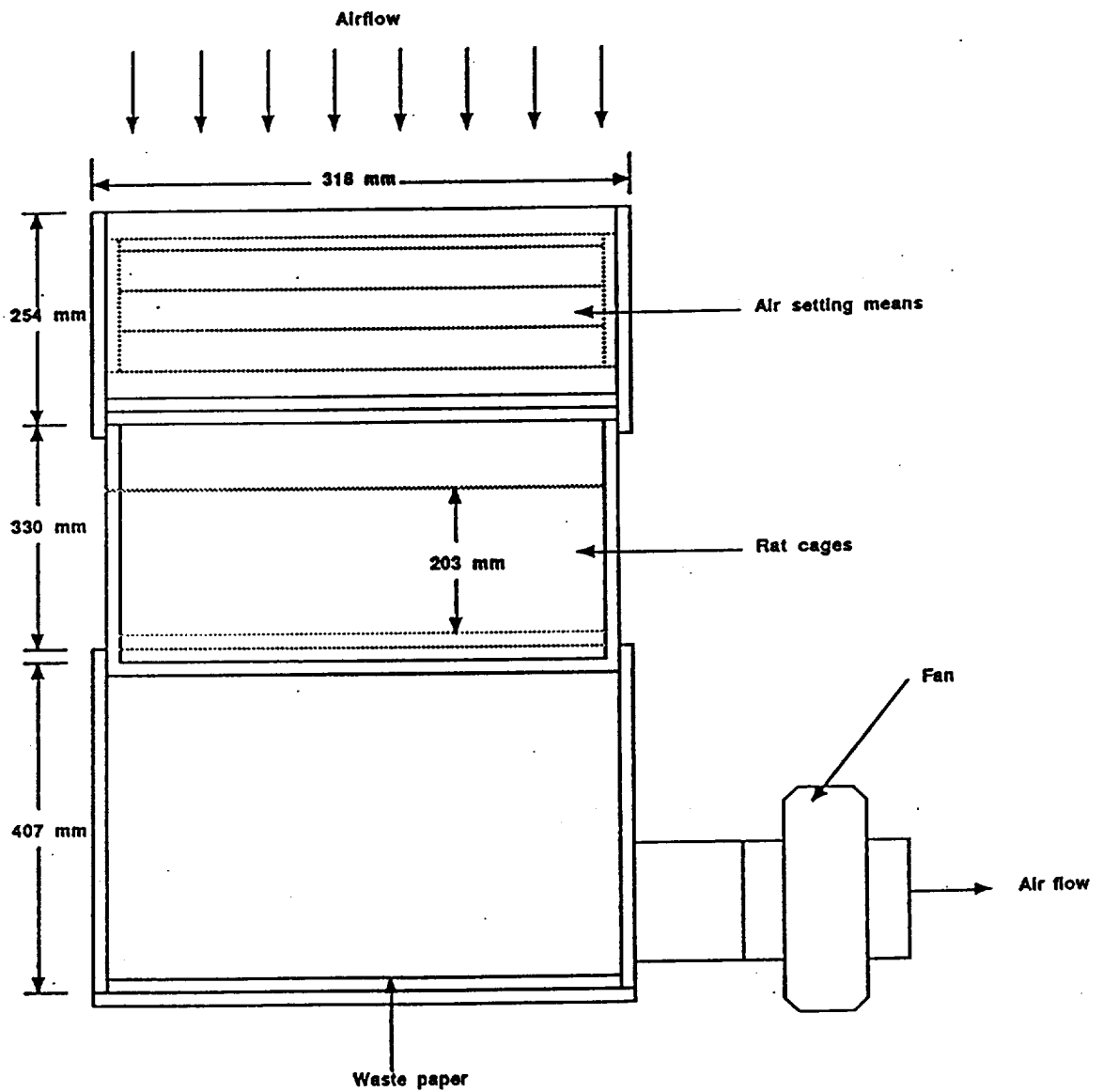

Figure 2. Diagram of the cage. Floor and top stainless steel welded wire mesh. Walls are 6.4 mm thick plexiglass, 305 mm wide x 432 mm long x 330 mm high. Wire floor and top were supported 203 mm apart.



Side View

Figure 3. Ventilation unit (depth is 445 mm) designed to hold four of the rat cages shown in Figure 2.

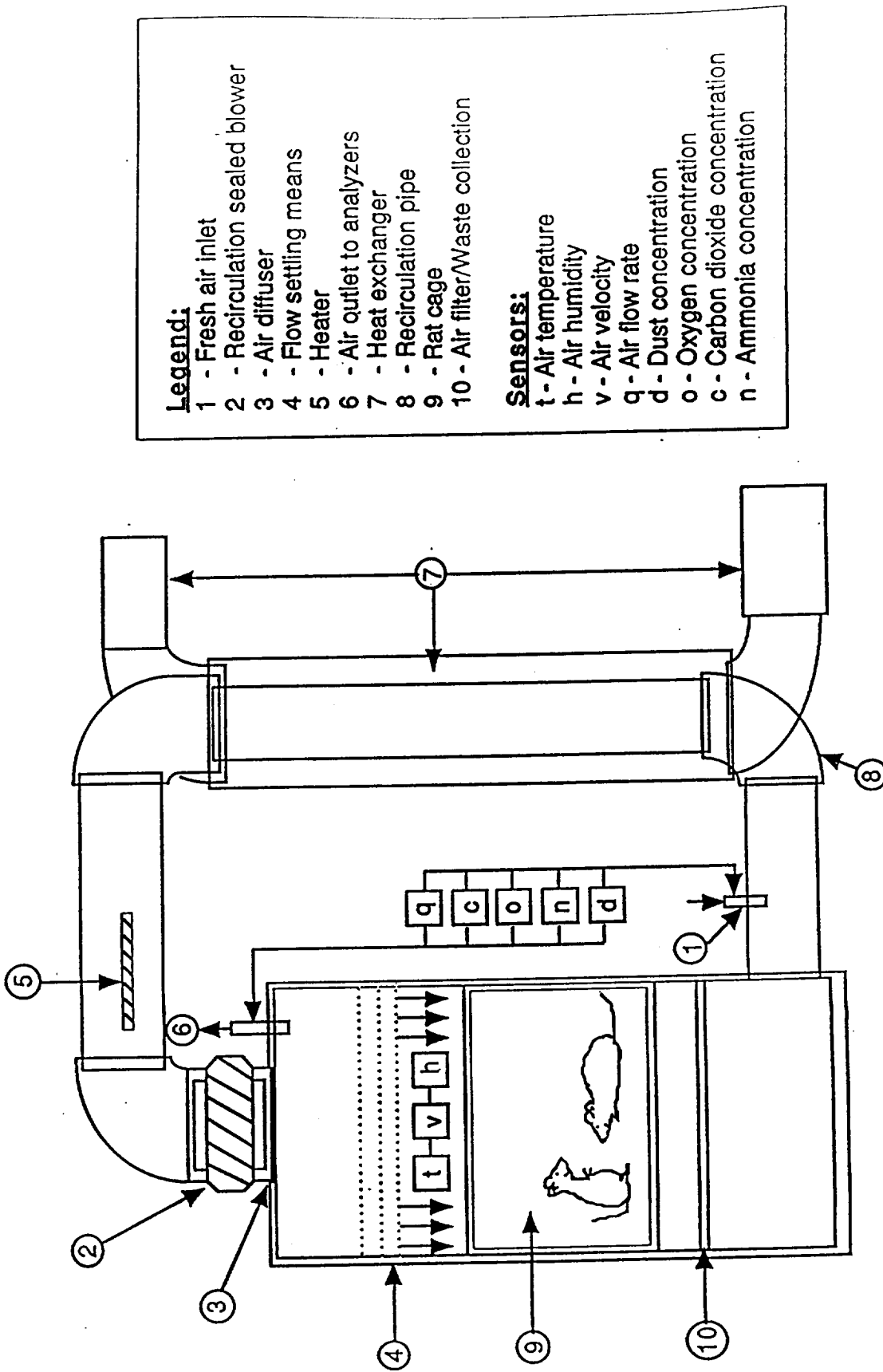
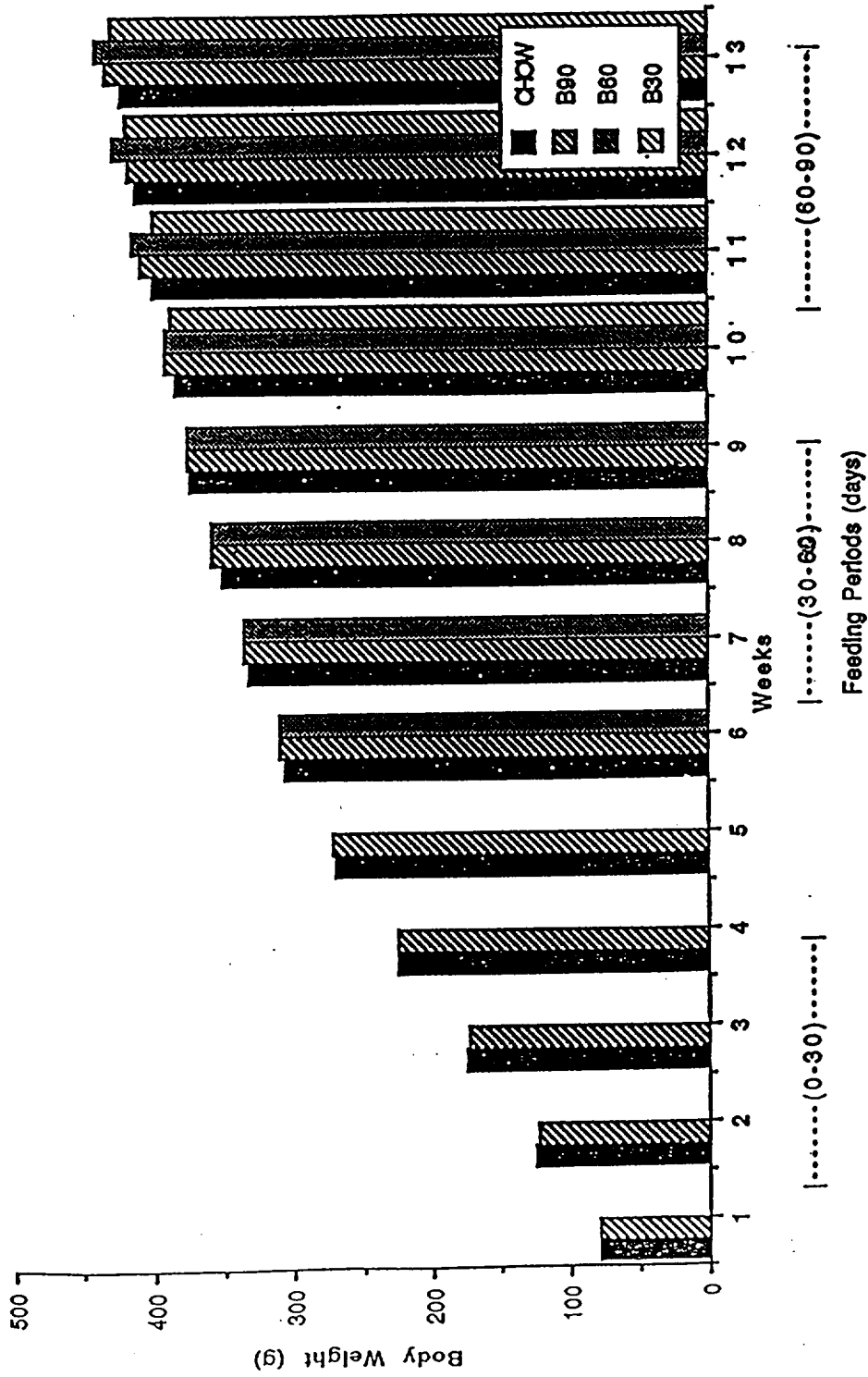

Figure 4. Schematic diagram of an indirect convective calorimeter.

Figure 5. Body Weight of Rats Fed Chow and RFB Diets at Different Ages ¹



¹See Table 11 for error terms and actual values
 Weeks with three bars indicate the time after which B60 treatment cages were changed from C to RFB and
 weeks with four bars indicate the time after which B30 treatment cages were changed from C to RFB.

Figure 6. Average Daily Feed Intake of Rats Fed Chow and RFB Diets at Different Ages ¹

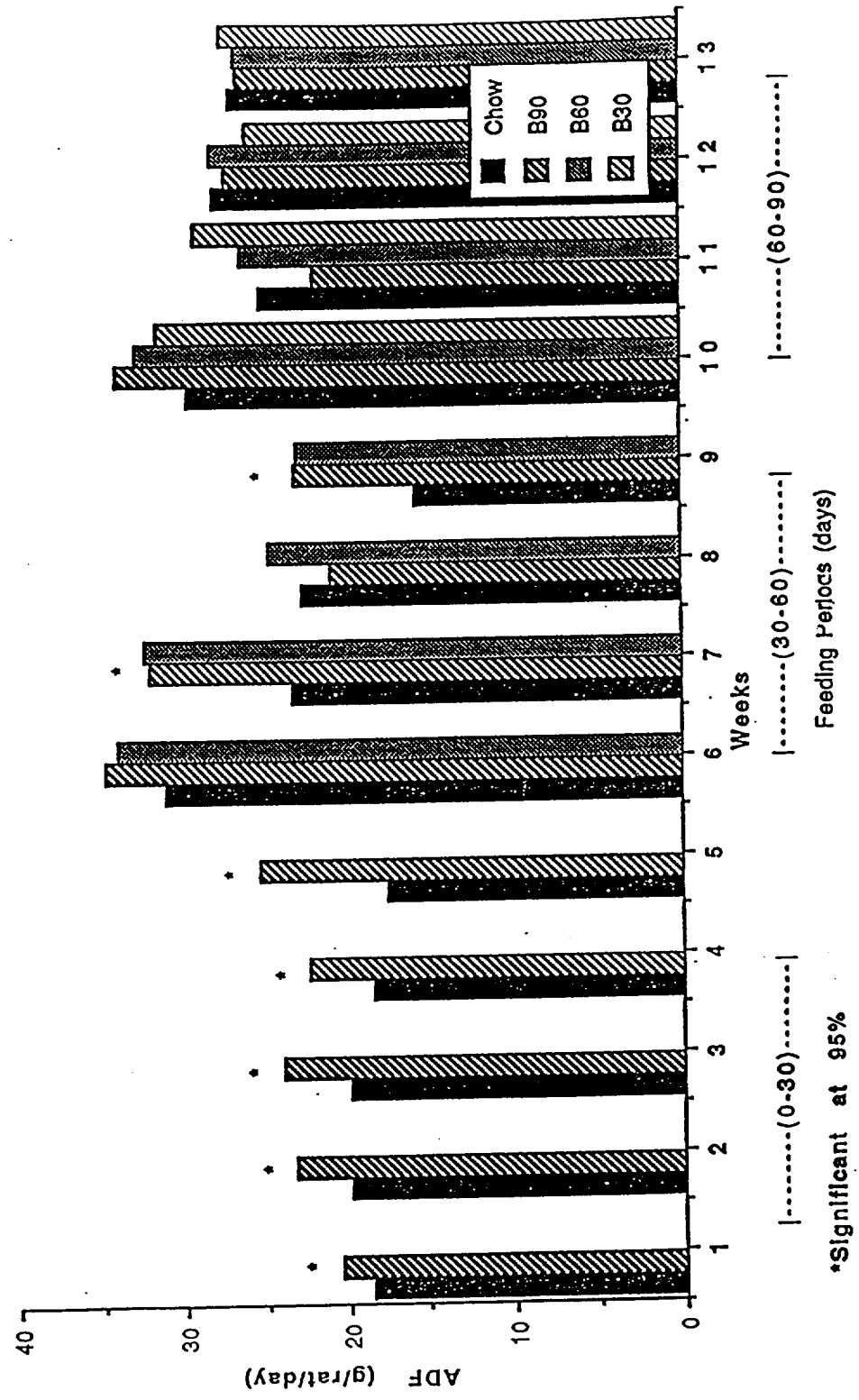

¹See Table 11 for error terms and actual values. Weeks with three bars indicate the time after which B60 treatment cages were changed from C to RFB and weeks with four bars indicate the time after which B30 treatment cages were changed from C to RFB.

Figure 7a. Average Daily Gain/Average Daily Feed of Rats Fed Chow and RFB Diets at Different Ages †

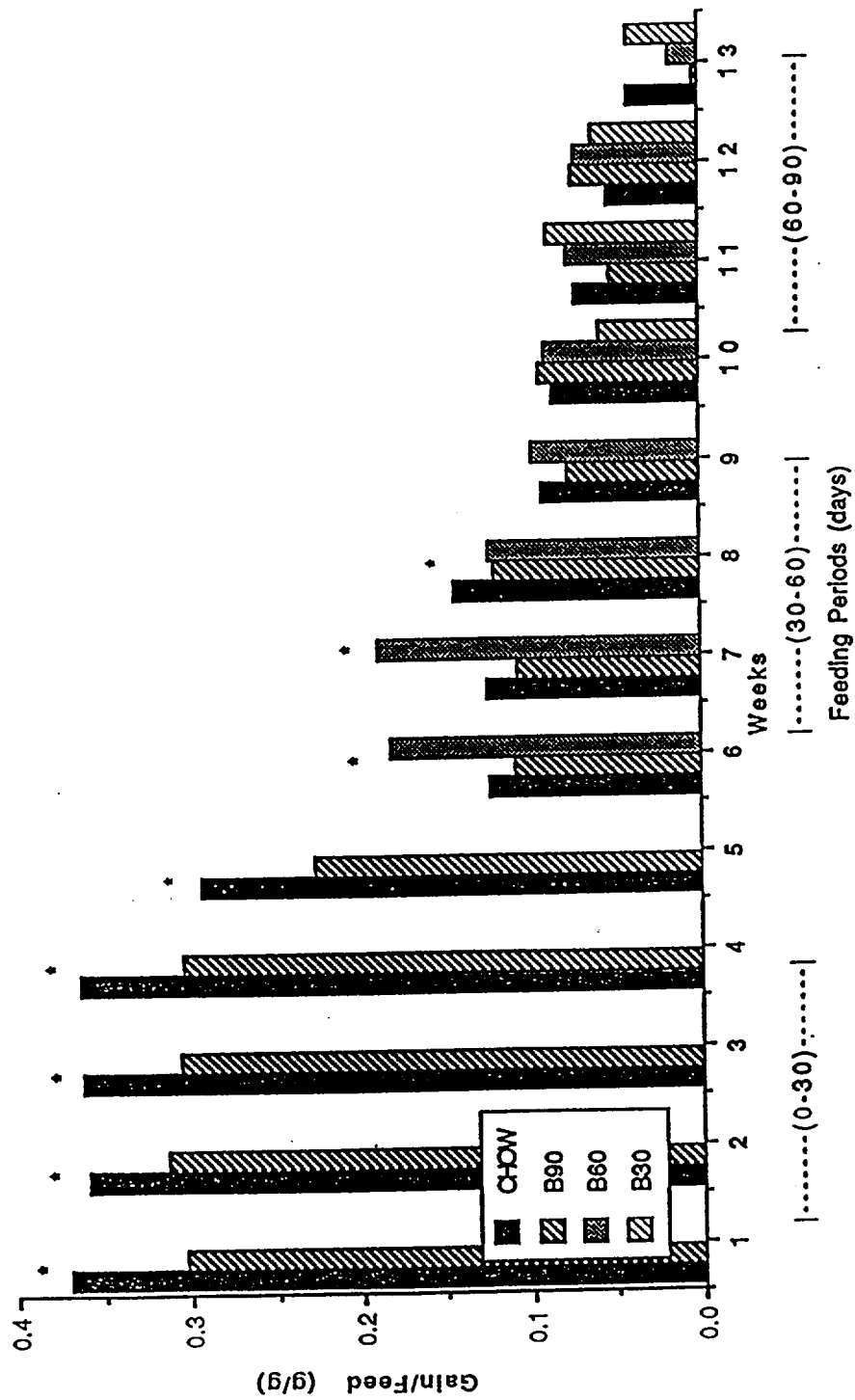

*Significant at 95%

†See Table 11 for error terms and actual values
 Weeks with three bars indicate the time after which B60 treatment cages were changed from C to RFB and weeks with four bars indicate the time after which B30 treatment cages were changed from C to RFB.

Figure 7b. Mean Average Daily Feed Intake (g)/Mean Body Weight (g) of Rats Fed Chow and RFB Diets at Different Ages ¹

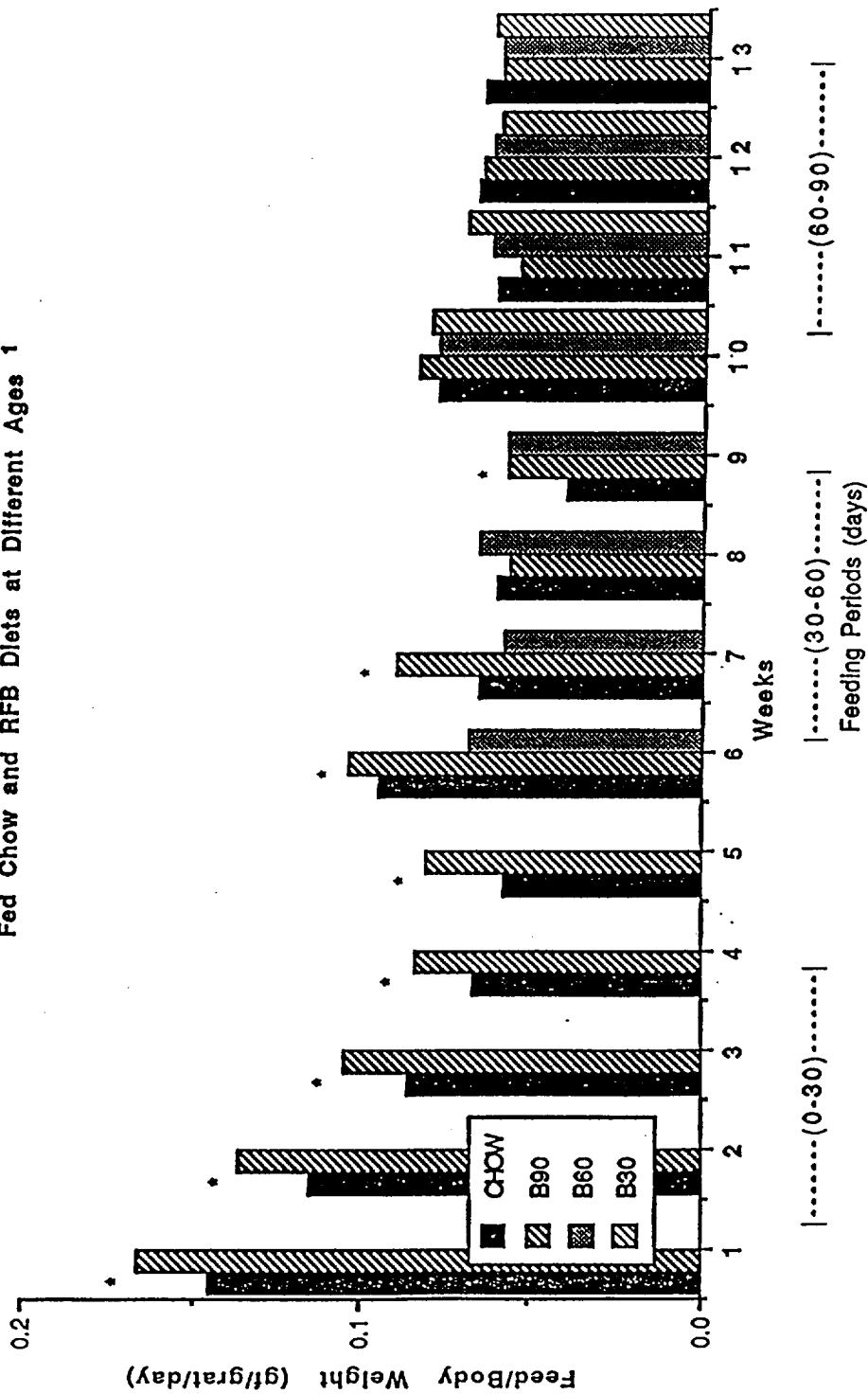

*Significant at 95%

¹See Table 11 for error terms and actual values

Weeks with three bars indicate the time after which B60 treatment cages were changed from C to RFB and weeks with four bars indicate the time after which B30 treatment cages were changed from C to RFB.

Figure 8. Average Daily Water Consumption of Rats Fed Chow and RFB Diets at Different Ages¹

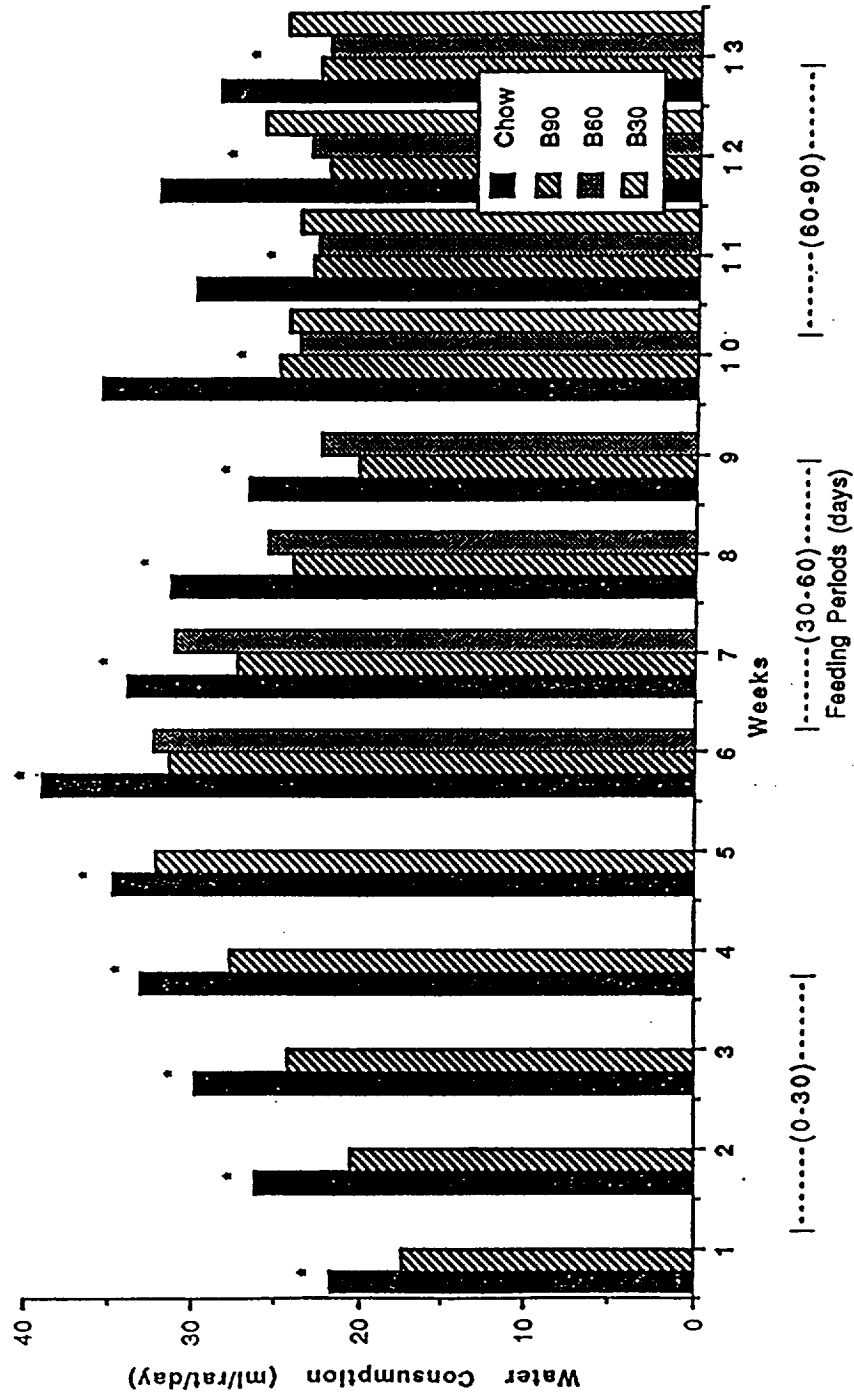

*Significant at 95%

¹See Table 11 for error terms and actual values

Weeks with three bars indicate the time after which B60 treatment cages were changed from C to RFB and weeks with four bars indicate the time after which B30 treatment cages were changed from C to RFB.



EFFECT OF DIET ON METABOLISM OF LABORATORY RATS

Effect of diet on carcass, fecal and urine characteristic of rats

Effects of diet reversal on feed and water intake

(A supplemental report)

The final report for the National Aeronautics and Space Administration

March 24, 1996

Investigators:

P.C. Harrison
G.L. Riskowski
J.S. McKee

Bioenvironmental Engineering Research Laboratory (BERL)
Animal Focus Group

University of Illinois at Urbana-Champaign

392 Animal Science Laboratory
1207 W. Gregory Drive
Urbana, IL 61801
(217)333-0069



TABLE OF CONTENTS

| | |
|---|-------------|
| ABSTRACT | S-1 |
| INTRODUCTION | S-2 |
| MATERIALS AND METHODS | S-2 |
| General Procedures | S-2 |
| Urine and Fecal Collection | S-3 |
| Carcass Composition | S-4 |
| Daily Responses Following a Change in Diet | S-4 |
| RESULTS AND DISCUSSION | S-5 |
| Carcass Composition | S-6 |
| Nitrogen and Water Balance | S-6 |
| Daily Responses Following Change in Diet | S-7 |
| GENERAL CONCLUSIONS AND SUMMARY | S-8 |
| TABLES | S-10 |
| FIGURES | S-18 |



ABSTRACT

Male (SD) rats fed a semipurified rodent food bar (RFB) diet, developed for Space applications, showed a decreased intestinal tissue mass but equal growth and energy conversion rates when compared to a natural (C) diet (McKee et al., 1995¹); therefore, this study was conducted to evaluate other possible partitioning of body tissue or nutrient utilization. Rats (n=224) were housed in a thermally controlled chamber in 28 separate (30.5 x 43.2 cm) individually ventilated cages (22°C and 0.13 m/s). Mean rat weight started at 78 g and 90-day weight was 446 g. After 30 and 60 days, six cages were shifted from C to RFB diet and at 30, 60, and 90 (B30, B60, B90) days housing density was reduced by two rats per cage. At 90 days, the two rats were euthanized in precharged CO₂ containers; viscera were removed and carcasses were frozen and saved for protein, water and fat analysis. Remaining rats from each dietary treatment (C, B30, B60, and B90) were placed in individual metabolism cages to determine feed and water consumption and fecal and urine production. Urine and feces were frozen and saved for analysis. A 95% level of significance indicated by ANOVA was used for inference. Feed intake was less for the C than the RFB treatments (24±0.6 vs 29±0.5 g/d/rat) and water intake was greater for the C than the RFB treatments (30±0.8 vs 20±0.7 ml/d/rat). For the C rats carcass protein (19.5%) and water (65%) was greater and fat (11%) was less when compared to the B90-RFB rats which was 19%, 63% and 13%, respectively. The C rats had a mean fecal weight of 8.2 g/d/rat with a moisture content of 36% and a 27% nitrogen level on a dry weight basis; these values were greater than the RFB treatments. Urine volume, weight, osmolality, and pH were the same for both diets. Urine nitrogen was 3.3 and 5.0% for C vs RFB, respectively. Reversal of the dietary treatments resulted in a reversal of the feed and water intake levels that had been measured previously. Change in diet from C to RFB resulted in over eating on the first days post diet change. The opposite response was observed for the RFB to C change and persisted for around four days.

In summary, the RFB and C diets had distinct effects on fecal characteristics and volumes, which in turn, influenced avenues of attaining water and nitrogen balance. The RFB diet stimulated over consumption of feed, especially after a diet change, which could be related to the higher lipid content in the RFB rats.

¹ McKee, J.S., P.C. Harrison, G.L. Riskowski and J. Johnson, 1995. Effects of diet on gastrointestinal and whole body growth of laboratory rats. FASEB 9(3); A3203.

INTRODUCTION

In a previous report male Sprague-Dawley (SD) rats had comparable body weights and energy exchange rates when fed either a processed, semipurified, rodent food bar (RFB) diet or a chow (C) diet which contained less processed feed ingredients. RFB diet or a change from C to RFB resulted in less gastrointestinal tract mass, fecal volume and water consumption. Also the change from C to RFB often resulted in a significant increase in feed consumption. These differences in feed and water intake were considered significant enough to warrant additional research concerning physiological responses to diet reversal, such as, body composition, water balance and nitrogen balance of the rats that had received combinations of these diets over a 90-day growth period.

Detailed and specific methodology, measurements and results are presented in the previous (attached) report "Effects of Diet on Metabolism of Laboratory Rats."

MATERIALS AND METHODS

GENERAL PROCEDURES

Male Sprague-Dawley (SD) rats ranging in age from approximately 17 to 22 wks with a mean body weight range between 440 to 496 g were used to obtain the data for this report. The rats had been reared in acclimation chambers in 30.5 x 43.2 cm cages from approximately four weeks of age and a mean body weight of 78 g. The acclimation chamber was environmentally controlled to maintain a temperature of 22°C and a relative humidity of around $55 \pm 5\%$. The rat cages were in units that controlled air to flow uniformly downward through the cages at a velocity of 0.13 m/s.

For the initial study, 224 rats were randomly assigned to 28 cages (8 rats/cage). Eight cages started on RFB (B90) and 20 cages started on C diet (Certified Rodent diet - 5002, Purina Mills, Inc.) (Table S-1). After the first 30-day feeding period, six of the 20 cages on C were changed to RFB (B60). After another 30-day feeding period, six of the remaining 14 cages on the C diet were changed to RFB (B30). Two rats had been removed from each of the 28 cages after 30, 60 and 90 days from the start of the experiment in order to obtain gastrointestinal tract tissue. The rat carcasses that remained from the 90-day gastrointestinal tract removal were used for carcass composition evaluation. The two remaining rats in each cage continued on their respective diets and were used for the urine, fecal and short term diet changes measured for this supplemental report.(Figure 1).

Data were analyzed using either single factor or repeated measures for analysis of variance (ANOVA) and a level of 95% significance, as indicated by Fischer's-Protected Least Squares Difference, was used

for inference purposes. In general, the rat was considered the experimental unit for statistical evaluation. All urine, fecal and carcass samples were coded prior to analysis and values reassigned to appropriate dietary treatments after sample analysis data was obtained. This procedure of treatment-blind and random-sequence analysis by laboratory technicians allowed for unbiased analysis of samples.

URINE AND FECAL COLLECTION

Collections were obtained from each of the dietary treatments (C, B90, B60, and B30). Four consecutive days of collection were individually taken for each of the two rats from six cages for each of the dietary treatments. The rats were individually housed in one of 12 metabolism cages (MC) and provided feed and water ad libitum. The entire collection period occurred over sixteen consecutive days (48 rats, 96 hours/collection period, 12 MC).

Each MC measured 203W x 267L x 168H mm. MC were constructed of stainless steel and had a funnel attached below the wire mesh floor of the cage. Urine and feces that passed through the floor were collected and separated by a small (2.5 cm²) pyramid located in the bottom of the funnel. The feces collected in the funnel, while the urine drained into a graduated container attached to the bottom of the funnel. Each MC also had an attached feeding-watering chamber that was 103 mm long and extended out the front of the cage. The rat had to enter this attached area to obtain food and water. The feeding-watering chamber floor was perforated and excess or spilled feed and water fell into a separate collection container before the rat moved back over the urine-fecal collection funnel area. (Fig. 6). Water was supplied by a "lixit" water nipple, which was the same as provided in their home cage. Feed was supplied in a cup attached to the bottom of the feeding chamber floor. RFB and C had to be ground in a Wareing blender to prevent the rats from carrying pieces of food over the urine and fecal collection floor area.

The following data were evaluated for the 4-day collection period:

- Urine volume (measured every 12 hours)
- Urine density (weight/volume, osmolality and specific gravity)
- Urine Nitrogen
- Urine electrolytes [Ca, Na, K and pH(H⁺)]
- Fecal weight
- Fecal moisture content
- Fecal nitrogen
- Feed consumption
- Water consumption

Urine osmolarity was determined from replicate samples from each rat using a freezing point osmometer (Fiske D.S. Fiske Assoc. Uxbridge, MA). Urine specific gravity was determined with a mercury urine hydrometer (1.000-2.060 Sp. Gr. Range; Thermometer Corp. Of America, Springfield, OH). Urine and fecal nitrogen was determined by standard micro Kjeldahl (Buchi 323, Brinkman Instruments, Westbury, NY) procedure on replicate samples from each rat. Urine calcium, sodium and potassium were also determined on replicates and compared against standard preparations using atomic absorption spectrophotometry (Perkin Elmer Model 306-AA, Norwalk CT). Fecal moisture was determined by change in weight of equal volumes of fecal samples that were oven dried at 100°C for 18-24 hours. Fecal and water consumption was measured on a weight in-out (g) or volume in-out (ml) basis, respectively, over 12-hour periods.

CARCASS COMPOSITION

Following the removal of the intestines, that were used for macroscopic and microscopic evaluation (see first report) after 90 days of dietary treatments, two rat carcasses from each (28) cage were frozen for carcass analysis. Both rat carcasses from each cage were ground, mixed and samples taken for replicate determination of moisture, protein and lipid content.

Carcass moisture was determined from duplicate (10g) samples which were oven dried at 100°C for 18-24 hours. Lipid content was determined by extraction with an azeotropic mixture of chloroform and methanol. Protein was estimated based on a protein: water = ~ 0.3. If duplicate samples did not agree within 10%, analysis of that sample was not used for evaluation.

DAILY RESPONSES FOLLOWING A CHANGE IN DIET

Eight rats that had been fed the RFB diet throughout the entire experimental period (approximately 17 weeks at the time of this experiment) were changed to the Chow diet and an equal number of rats that had always been fed C were changed to NSB. At the start an initial feed weight and water volume, was given to each of eight cages (two rats/cage) and feed and water leftovers were subsequently recorded on a daily basis. Feed and water were supplied ad libitum. Feed, water and body weight were recorded for six days prior to diet changes (Pre). Following diet reversals the same parameters (feed, water, and body weight) continued to be recorded daily for seven consecutive days (Post).

RESULTS AND DISCUSSION

Data collected from the rats during the four days of MC evaluation are shown in Table S-2. Rats that were receiving the Chow diet ate less feed, drank more water and produced more feces than any of the RFB treatments. There were no significant differences between any of the RFB (B90, B60 and B30) treatments.

There was a significant ($P < .05$) day effect on feed intake, water consumption and fecal production. The first day of the four-day MC evaluation was different from the other three days; however, significant dietary treatment effects were the same on the first day as they were each day for the entire four day treatment period. Feed intake was the lowest for the C treatment on day one of MC exposure and highest for the RFB treatments. Water consumption was highest on day one for all dietary groups and fecal production was lowest regardless of diet. There were no replication or cage effects during the MC evaluation.

Fecal constituents are shown on Table S-3. Fecal samples had significantly higher moisture and nitrogen content for the C when compared to all the RFB diets. There were no significant replication effects, therefore factorial analysis was used instead of repeated measures analysis. The relative contribution of microbial nitrogen was not determined; however, in the larger mass of feces produced by the C rats it was assumed that microbial nitrogen could account for some differences in fecal nitrogen. This question should be more extensively investigated.

Urine constituents are shown on Table S-4. Urine samples from the C treatment had less nitrogen than the RFB diets, while all the RFB treatments were the same. These urine nitrogen levels were opposite the dietary treatment effects on fecal nitrogen.

Urine sodium was higher in the C than in the B60 and B30 treatments receiving the RFB diet. There were no sodium differences between RFB treatments. Potassium was also greater in the C treatment than any of the RFB treatments. Calcium was not significantly different but was higher for the C urine when compared to the RFB treatments, B60 and B30 ($P < 0.1$). This higher level of urine electrolyte concentration may be reflective of a renal exchange with hydrogen ions. Even though there was no significant treatment effect on urine pH (or H^+ when calculated from individual urine pH values) there was an indication (smaller error term) that H^+ were being regulated in the C treatment. However, greater numbers with a different experimental protocol would be required to evaluate the acid-base status of these animals.

CARCASS COMPOSITION

Protein, lipid and water content of rat carcasses from the C and RFB dietary treatments are shown in Table S-5. There was no difference in live body weight between the rats used for carcass analysis. Intestinal tissue both full and empty (Saline flushed) were greater for the C treatment when compared to all RFB treatments (data from previous report). Remaining carcass tissue, after intestine removal, had a greater proportion of protein, less fat, and more water on a percentage basis for the C treatment when compared to all RFB treatments.

NITROGEN AND WATER BALANCE

One of the more interesting differences was the general nitrogen and water equilibrium processes that occurred between the C and RFB rats (Table S-6 and S-7). Rats on the C diet excreted less nitrogen in urine and more in the feces than those on the RFB diets. The C rats produced more feces with a higher percent nitrogen (Table S-3). Urine volume was about the same for all diets but the C treatment rats had a lower urine nitrogen level (Tables S-2 and S-4).

Regardless of diet source, rats retained between 8 and 9 percent of dietary nitrogen as carcass nitrogen. All dietary treatments showed a negative (in -[out + retained]) nitrogen balance. The small negative balance could be accounted for by the visceral tissue and contents, for which we do not have data. The larger -1.29 g/rat/day balance for the C rats probably reflects not only visceral tissue and contents, but a substantial hindgut microbial nitrogen content. However, additional experiments need to be conducted to evaluate how much of the fecal nitrogen is from microbial sources.

Differences in water balance are also associated with the fecal differences between diet treatment (Table S-7). The C rats again produced more feces with a higher level of moisture. The C rats drank more water and produced about the same urine volume; however, fecal water loss was 400 percent greater in the C rats when compared to RFB rats. Since urine volume was the same in C and RFB rats, and the greater loss of body water in the feces of C rats did not influence urine volume, it would appear that the increase in body water loss was compensated by increased drinking. This represents a unique water equilibrium process for the C rats, in that thirst, rather than renal processes, appears to be the regulatory mechanism for water balance. The C treatment also retained the least amount of consumed water in the form of total carcass water. However, retained water, as was retained nitrogen, is based on carcass data (Table S-5) obtained from different rats.

Water balance (in -[out + retained]) was the opposite of that seen for nitrogen balance and showed a greater amount of water consumed than could be accounted for by urine, fecal and carcass water. From

the previous report it is obvious that water is being lost by evaporation from animal surfaces. The greatest disparity in water balance occurred in the C treatment. This disparity again could be accounted for by the treatment differences in intestinal tissue and contents. Table 5 indicates that the C rats should have more visceral tissue with greater visceral contents than any of the RFB treatments. Based on observation and fecal moisture measurements, the water content of visceral materials in the C rats was also greater. For example, the C rats contained 15.8g of intestinal contents, while the mean for the RFB treatments was 7.5g; the difference between the C and RFB contents is 8.3g and when the 7.54 ml/rat/day "Balance" is subtracted from the 8.3g difference in intestinal contents the water Balance is more in line with the other values in the Balance column (Table S-7). Also there was no indication in the previously reported data that the C rats would be generating or losing metabolic water different from any of the RFB rats.

DAILY RESPONSES FOLLOWING A CHANGE IN DIET

Responses to a change in diet from C to RFB and RFB to C are shown in Table S-8. The C rats had a lower mean body weight at the start of the measurement period for evaluation of the daily effects of a diet change. From Table S-8 and Fig. S-3, it can be seen that the rats on C and RFB diets were gaining weight on their respective diets. After a reversal of the diets there was not a significant difference in the average daily change in body weight. The reason for the lack of a significant difference in change in daily body weight was caused by the variance that occurs from day to day in an animal's body weight (Figure S-3). However, the rats continued to grow regardless of change in diet. During the week following the diet change, those rats that were changed from C to RFB diets had a significant mean total body weight increase of 19 grams, whereas, those switched from RFB to C only gained 9 grams. Both food intake and water intake were significantly influenced by diet change. Rats that were changed from C to RFB increased feed consumption and decreased water consumption; however, the opposite food and water intake responses were measured for the rats subjected to the RFB to C change.

The time course of these responses to a diet reversal can be more clearly seen in Figures S-1 thru S-5. The most obvious and early response observed was the change in food intake (Figures S-1, S-2 and S-4). Within the first daily measurement period, those that received the C to RFB change showed a dramatic increase in feed consumption; whereas those receiving the RFB to C treatment showed an opposite response. Within four days following the diet change both treatments had attained a new steady state of daily feed consumption.

This early food intake response may relate to the differences in carcass composition (Table S-5). In both humans and rats, increased consumption of food for even short periods of time will lead to increased

body fat deposition. Research reported by ¹Rolls and Rowe (1982) demonstrated that adding variety, such as chocolate, cookies and crackers, to rodent diets on a periodic basis increased short term feed consumption and significantly increased fat pad deposition. In our previous report we found that rats on both C and RFB diets had similar metabolic energy expenditures and respiratory quotients; however, those that received the RFB had a significantly greater carcass lipid content. We suspect that the higher carcass lipid in the RFB treatments reflects this period of over eating and under eating that occurred during the early transition from C to RFB and RFB to C, respectively. The fact that the metabolic rate, respiratory quotient and growth rate were similar for both C and RFB treatments, in turn, reflects the fact that the energy balance measurements were taken thirty days after the diet change and a new steady state feeding pattern had occurred. Also some evidence indicates that when equal but isolated feed components (purified or semipurified ingredients) are used as a diet source, there is an increase in body lipid content (Novakofski, J.E. personal communication).

Water consumption pattern (Figure S-1, S-2 and S-5) followed the same but opposite direction that was observed for feed consumption, following diet changes. Water consumption changes were not as abrupt as those seen for daily food intake and appeared much more variable. Whether the variability in water intake reflects true consumption variance or physical problems associated with drinking could not be determined. It is interesting to note that, after diet changes, those daily periods (day-4 for the C to RFB and day-6 for the RFB to C treatments) that had low water intake values also had a low or even negative change in body weight.

GENERAL CONCLUSIONS AND SUMMARY

1. Rats maintained on the RFB diet consumed more feed and less water than those on the C diet.
2. Rats maintained on the RFB diet produced less feces volume and weight with a lower moisture and nitrogen content than those on the C diet.
3. Rats maintained on the RFB diet produced essentially equal volumes of urine with a higher nitrogen and lower sodium, potassium and calcium content than those on the C diet.
4. Rats maintained on the RFB diet had a consistently, but not significant, larger body weight and their carcass tissue was higher in fat but lower in protein and water proportions than the C fed group.

¹Rolls, B.J., and E.A. Rowe. 1982. Variety in the diet enhances intake in a meal and contributes to the development of obesity in the rat. *Physiol & Behav* 31:21-27.

5. Rats maintained on the RFB diet showed a consistent negative estimate of nitrogen balance and positive water balance. Rats on the C diet had a much greater disparity in both nitrogen and water balance and both of these imbalances appear to be related to the difference in gastrointestinal tissue, and fecal mass and moisture.
6. Water balance in the C rats appears to be regulated by thirst, rather than renal mechanisms. Urine volume was the same for C and RFB rats and the increased body water loss in the feces of the C rats were compensated by increased drinking.
7. Reversal of the diets caused a reversal of feed and water consumption levels. During the first 1 to 4 days after the diet reversal there was a period of over eating and under eating for the C to RFB and RFB to C treatments, respectively. The over eating and under eating period following the diet change could be cause-effect related to the differences in carcass composition.

In future investigations differences in gastrointestinal microbial populations may be of benefit to help understand the differences observed between the RFB and C rats. Also GI microbial characterization will be important when comparing nutrition experiments under space station conditions to earthbound environments.

Table S-1. Comparison of feed components

| Ingredient | Diets* | |
|-------------|----------|---------|
| | Chow (%) | RFB (%) |
| Protein | 21.2 | 21.5 |
| Fat | 5.6 | 4.8 |
| Crude fiber | 4.4 | 3.8 |
| Moisture | 8.8 | 26.9 |
| Calcium | 0.82 | 0.73 |
| Phosphorus | 0.63 | 0.57 |
| Ash | 7.0 | — |
| ME (Kcal/g) | 3.41 | 3.75 |

*RFB = rodent food bar – Harlan Teklad diet TD 93062. Diet components for this diet were based on 8.8% moisture prior to processing. Processing of Teklad diet into RFB was by the American Institute of Baking, Manhattan, KS.

Chow = Certified rodent diet - 5002; Purina Mills, Inc.

Table S-2. Mean metabolic cage measurements.¹

| Measurement Variable | Dietary Treatment | | | |
|--|-------------------|----------------------------|----------------------------|----------------------------|
| | Chow | B90 | B60 | B30 |
| Body Weight Gain ² (g/rat/day) | 2.08±0.56 | 2.71±0.36 | 3.13±0.64 | 2.97±0.40 |
| Feed Intake (g/rat/day) | 23.55*±0.603 | 29.00±0.525 | 29.82±0.518 | 29.48±0.596 |
| Water Intake (ml/rat/day) | 29.60*±0.816 | 20.77±0.856 | 19.75±0.768 | 19.89±0.668 |
| Fecal Production (g/rat/day) | 8.22*±0.302 | 3.67±0.159 | 3.96±0.196 | 3.85±0.200 |
| Urine Production (ml/rat/day) | 17.78*±0.495 | 16.65 ^{ab} ±0.603 | 16.49 ^{ab} ±0.581 | 15.97 ^{bc} ±0.489 |

¹Measurements were taken at 12 hour intervals over a continuous four day period for 12 rats/diet.

*Values are significantly different ($P < .05$) from other values in the same row.

²Body weight in-out were used to evaluate average daily gain and factorial ANOVA was used for analysis of all variables.

^{a-b}Means in a row with no common superscript differ ($P < .05$).

Table S-3. Characteristics of rat feces collected during metabolic cage measurements.¹

| Fecal Variable | Dietary Treatments | | | |
|----------------|--------------------|-------|-------|-------|
| | Chow | B90 | B60 | B30 |
| Moisture (%) | 35.67* | 18.33 | 19.12 | 17.41 |
| SEM | 1.47 | 0.71 | 1.20 | 1.08 |
| Nitrogen (%) | 27.51* | 15.57 | 16.15 | 15.82 |
| SEM | 0.67 | 0.63 | 0.58 | 0.47 |

¹Feces were collected and weighed at 12 hour intervals on a daily basis. Individual rat (12/treatment) collections were pooled and stored in refrigerated sealed containers during the four day collection, then frozen until analyzed for moisture and nitrogen. Percent is expressed on a total dry weight basis.

*Values are significantly different ($P < .05$) from other values in the same row. All values were obtained from factorial ANOVA analysis ($n = 12/\text{treatment}$).

Table S-4. Characteristics of rat urine collected during metabolism cage measurements.¹

| Urine Variables | Dietary Treatments | | | |
|---------------------------------|--------------------|--------------------|-------------------|--------------------|
| | Chow | B90 | B60 | B30 |
| Urine Weight(g/rat/day) | 18.33 | 17.15 | 16.67 | 16.48 |
| SEM | 1.85 | 1.85 | 1.85 | 1.85 |
| Urine Density(specific gravity) | 1.031 | 1.030 | 1.011 | 1.032 |
| SEM | .009 | .009 | .009 | .009 |
| Urine Osmolarity(osmoles) | 1.786 | 1.878 | 1.887 | 1.903 |
| SEM | .175 | .175 | .175 | .175 |
| Urine pH | 8.51 | 7.88 | 8.01 | 8.19 |
| SEM | .14 | .33 | .31 | 0.28 |
| Urine Nitrogen(%) | 3.21 ^a | 4.33 ^b | 4.48 ^b | 4.53 ^b |
| SEM | 0.22 | 0.32 | 0.29 | 0.33 |
| Urine Na (meq/L) | 101.2 ^a | 84.7 ^{ab} | 81.4 ^b | 74.62 ^b |
| SEM | 8.0 | 5.0 | 8.2 | 5.1 |
| n | 9 | 10 | 9 | 10 |
| Urine Ca (meq/L) | 2.68 | 1.80 | 1.54 | 1.62 |
| SEM | .36 | .44 | .45 | .42 |
| n | 9 | 12 | 10 | 11 |
| Urine K (meq/L) | 18.29 ^a | 9.72 ^b | 8.82 ^b | 8.82 ^b |
| SEM | 1.16 | .66 | .50 | .58 |
| n | 9 | 10 | 9 | 10 |

¹Analysis was taken for individual rat urine samples (n = 12 rats/treatment). Urine weight, density and osmolarity was evaluated for repeated measurements over days (pooled SEM). Other analysis was taken on pooled (days) urine samples from each of the 12 rats/treatment. Values represent mean ± SEM values from replicate sample analysis using factorial analysis. Where n does not equal 12, replicate samples had an associated error term that was significant enough to warrant elimination from the overall analyses.

^{a-b}Means in a row with no common superscript differ (P < .05).

Table S-5. Characteristics of rat carcasses after 90 days of Chow and Rodent Food Bar diets.¹

| Carcass Variable | Dietary Treatments | | | |
|-----------------------------|--------------------|--------------------|--------------------|--------------------|
| | Chow | B90 | B60 | B30 |
| Live Body Weight (g) | 439.6 | 443.6 | 458.9 | 439.8 |
| SEM | 6.4 | 7.4 | 9.5 | 9.6 |
| Intestinal Weight full (g) | 31.4 ^a | 20.9 ^b | 20.3 ^b | 19.9 ^b |
| SEM | 0.7 | 0.7 | 0.8 | 0.8 |
| Intestinal Weight empty (g) | 15.6 ^a | 12.6 ^b | 13.0 ^b | 13.0 ^b |
| SEM | 0.3 | 0.3 | 0.4 | 0.4 |
| Carcass Protein (%) | 19.52 ^a | 18.96 ^b | 19.15 ^b | 19.02 ^b |
| SEM | .03 | .07 | .09 | .11 |
| Carcass Lipid (%) | 10.84 ^a | 12.79 ^b | 12.95 ^b | 12.66 ^b |
| SEM | .19 | .36 | .43 | .34 |
| Carcass Water (%) | 65.05 ^a | 63.20 ^b | 63.8 ^b | 63.4 ^b |
| SEM | 0.10 | 0.24 | 0.29 | 0.37 |

¹Values of carcass components are from individual samples within treatments and error terms are from factorial ANOVA (n=6). Values for body weight and intestinal weights are from individual rats (n=16 for C and B90 and 12 for B60 and B30).

^{a,b}Means in a row with no common superscripts differ (P < .05).

Table S-6. Metabolism cage evaluation of nitrogen equilibrium.¹

| Diet Treatment | Nitrogen Balance* | | | | Balance g/rat/day |
|----------------|----------------------------|---------------------------|-------|--------------------------------|----------------------|
| | Nitrogen In (g/rat/day) | Nitrogen Out g/rat/day | | Nitrogen Retained g/rat/day | |
| | feed | Urine | Feces | Carcass | |
| Chow | 0.799 | 0.571 | 1.45 | .065 | -1.29 |
| B90 | 0.998 | 0.7209 | 0.48 | .082 | -0.29 |
| B60 | 1.026 | 0.739 | 0.52 | .096 | -0.33 |
| B30 | 1.014 | 0.723 | 0.50 | .090 | -0.30 |

¹Since values were calculated from data taken in different experiments and previously reported in other tables, statistical analysis is not presented. Statistical inference values can be obtained for the calculation components from the previous tables.

*In = $\frac{\text{Average Daily Feed} \times \% \text{ Food Protein}}{6.25}$

Out = Average Daily Urine Production X % N = Urine

Out = Average Daily Fecal Weight (dry) x % N = Feces

Retained = $\frac{\text{Average Daily Gain} \times \% \text{ Carcass Protein (90 day Rats)}}{6.25}$

Balance = In - (Out + Retained)

Table S-7. Metabolism cage evaluation of water equilibrium.¹

| Diet Treatment | Water Balance* | | | | |
|----------------|----------------|------------|-------|----------------|------------|
| | Water In | Water Out | | Water Retained | Balance |
| | (ml/rat/day) | ml/rat/day | | ml/rat/day | ml/rat/day |
| | | Urine | Feces | Carcass | |
| Chow | 29.60 | 17.78 | 2.93 | 1.35 | 7.54 |
| B90 | 20.77 | 16.65 | 0.69 | 1.71 | 1.72 |
| B60 | 19.75 | 16.49 | 0.76 | 2.00 | 0.50 |
| B30 | 19.89 | 15.97 | 0.67 | 1.88 | 1.37 |

¹Same as Table 6

*Fecal Water = Fecal wt/day(g) x % Moisture

Water Retained = Average daily gain(g) x % Carcass water (90 day Rats)

Balance = In - (Out + Retained)

Table S-8. Response of rats to a change in diet.¹

| Variables Measured | Diet Change ³ | | | |
|--|--------------------------|-------------------------|-------------------------|-------------------------|
| | Chow to RFB | | B90 to Chow | |
| | Pre | Post | Pre | Post |
| Mean Body Weight (g) ² | 467±3.9 ^a | 486±3.9 ^b | 496±3.1 ^a | 505±3.1 ^b |
| Average Daily Gain (g) ² | 1.55±1.01 | 3.21±0.99 | 1.18±0.34 | 1.84±1.38 |
| Food Intake (g/rat/day) ² | 29.95±1.17 ^a | 39.19±1.02 ^b | 32.27±0.38 ^a | 25.3±1.36 ^b |
| Water Intake (ml/rat/day) ² | 37.38±1.67 ^a | 30.68±1.41 ^b | 22.74±0.96 ^a | 30.33±2.14 ^b |

¹Data for each diet change was taken from eight rats in four cages that had received either Chow or RFB during the entire experimental period. Measurements were taken daily for six days prior to change and for seven days after the diet change.

²Body weight was analyzed by ANOVA repeated measures on eight individual rats on days 1-6 (Pre) and days 7-13 (Post) for each diet change. All other variables were analyzed by cage (two rats per cage) and values divided by two to express data on a rat/day basis.

³Pre measurements were analyzed for a six day period prior to diet change and Post was analyzed for seven days.

^{a-b}Means in a row within a diet change column (e.g. C to RFB), with no common superscript differ (P < .05)

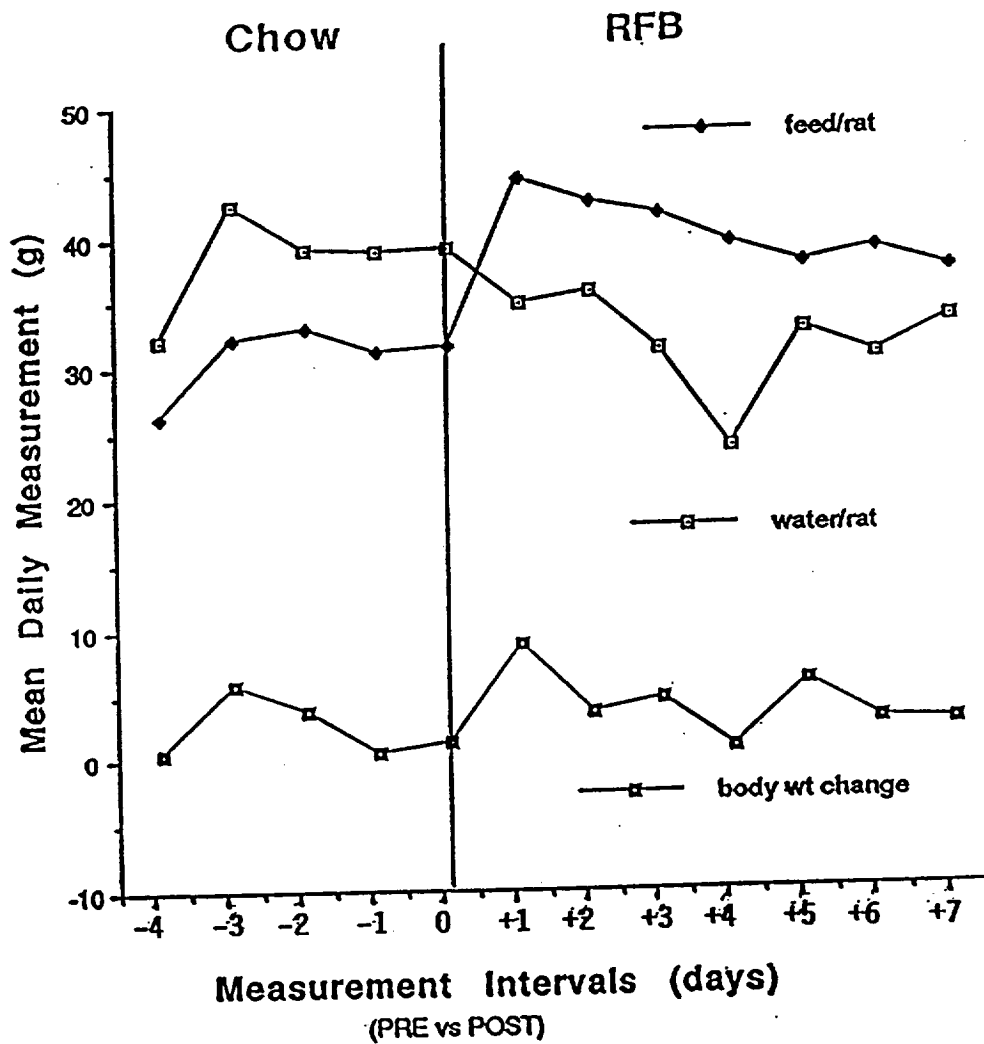

Figure S-1. Daily responses of rats to a change in diet from chow (PRE) to rodent food bar (POST)

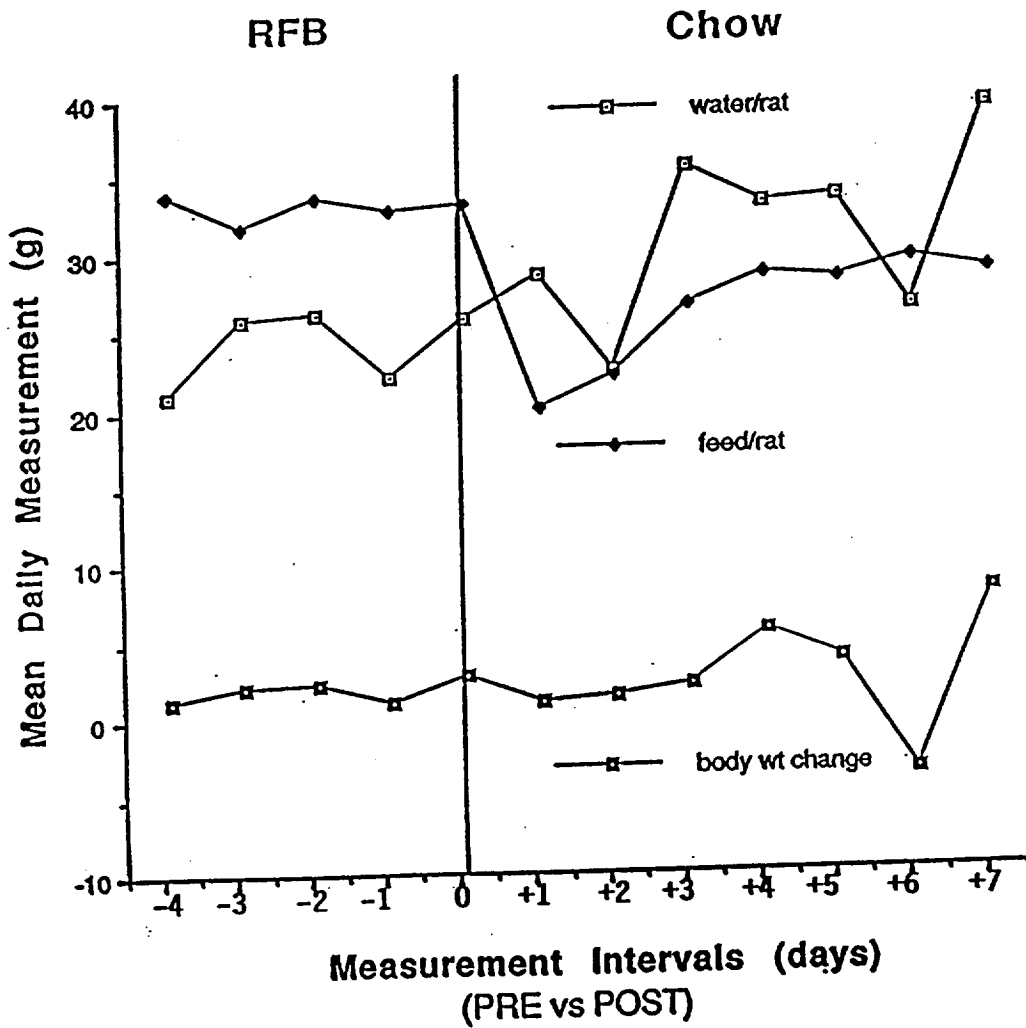

Figure S-2 Daily responses of rats to a change in diet from rodent food bar (PRE) to chow (POST)

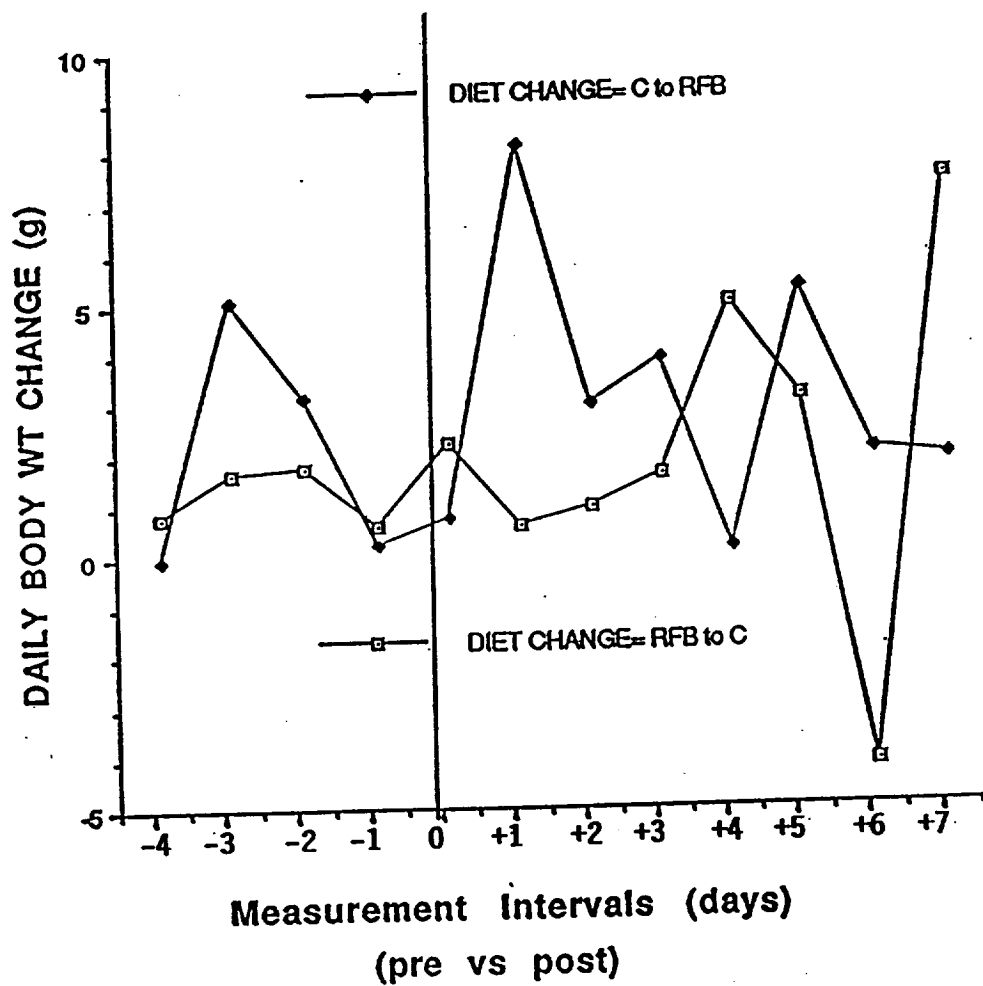

Figure S-3. Daily body weight response of rats to change in diet.
 C = chow; RFB = rodent food bar

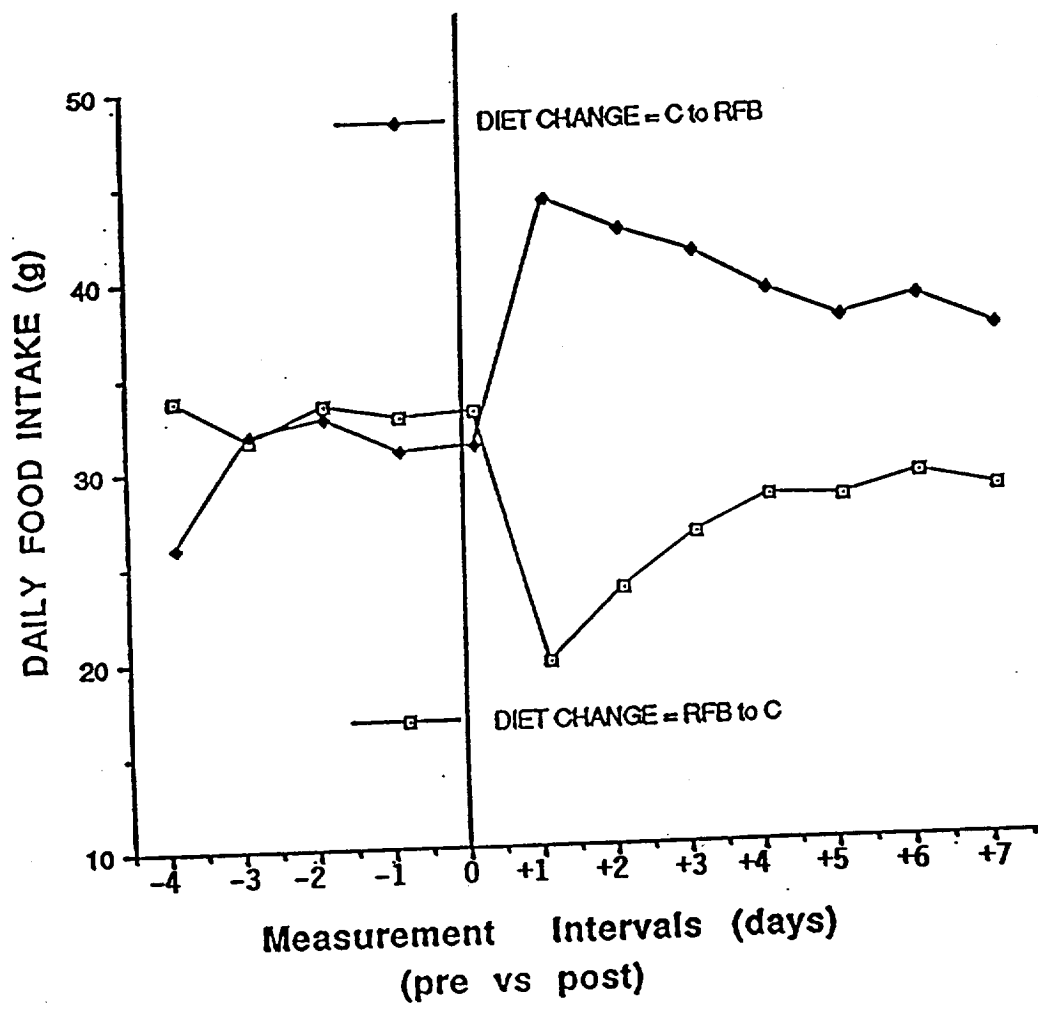

Figure S-4. Daily food intake response of rats to a change in diet. C = chow; RFB = rodent food bar

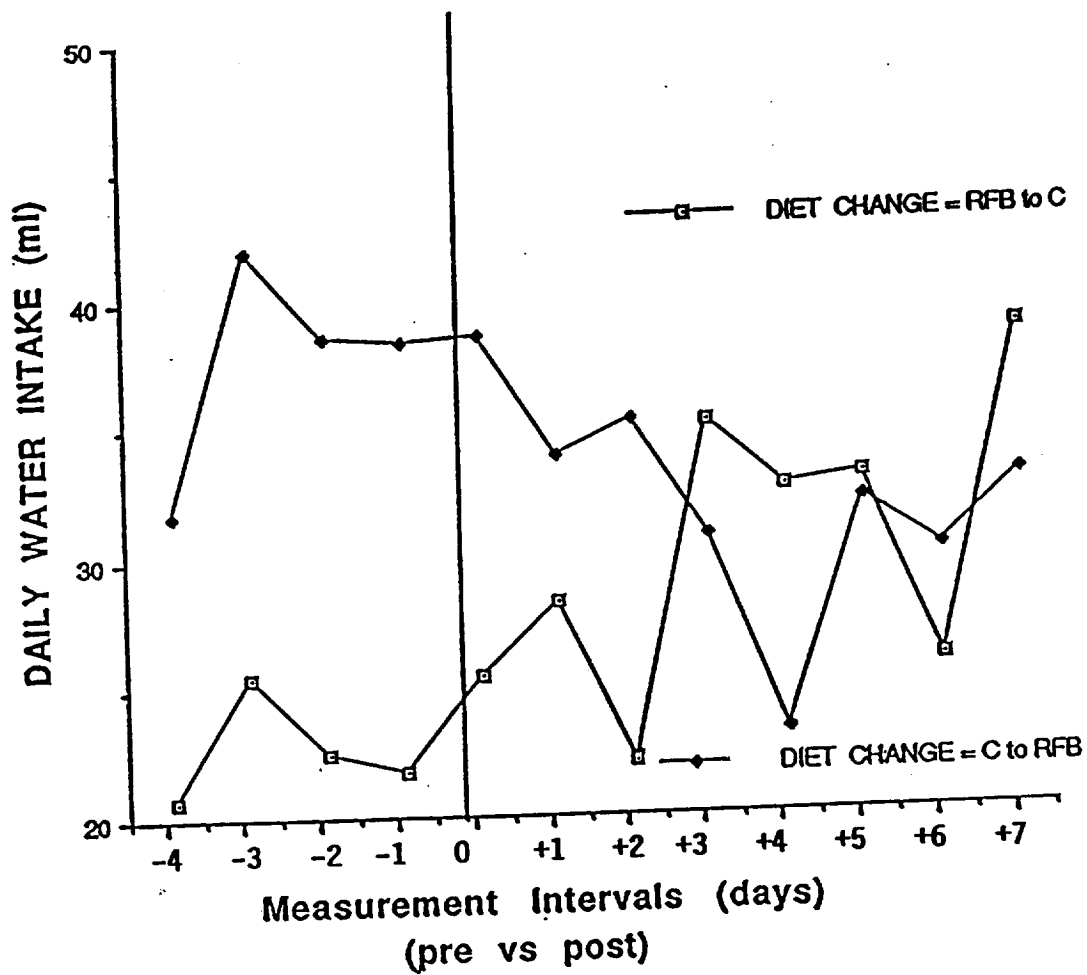

Figure S-5. Daily water intake response of rats to a change in diet.
 C = Chow; RFB = rodent food bar

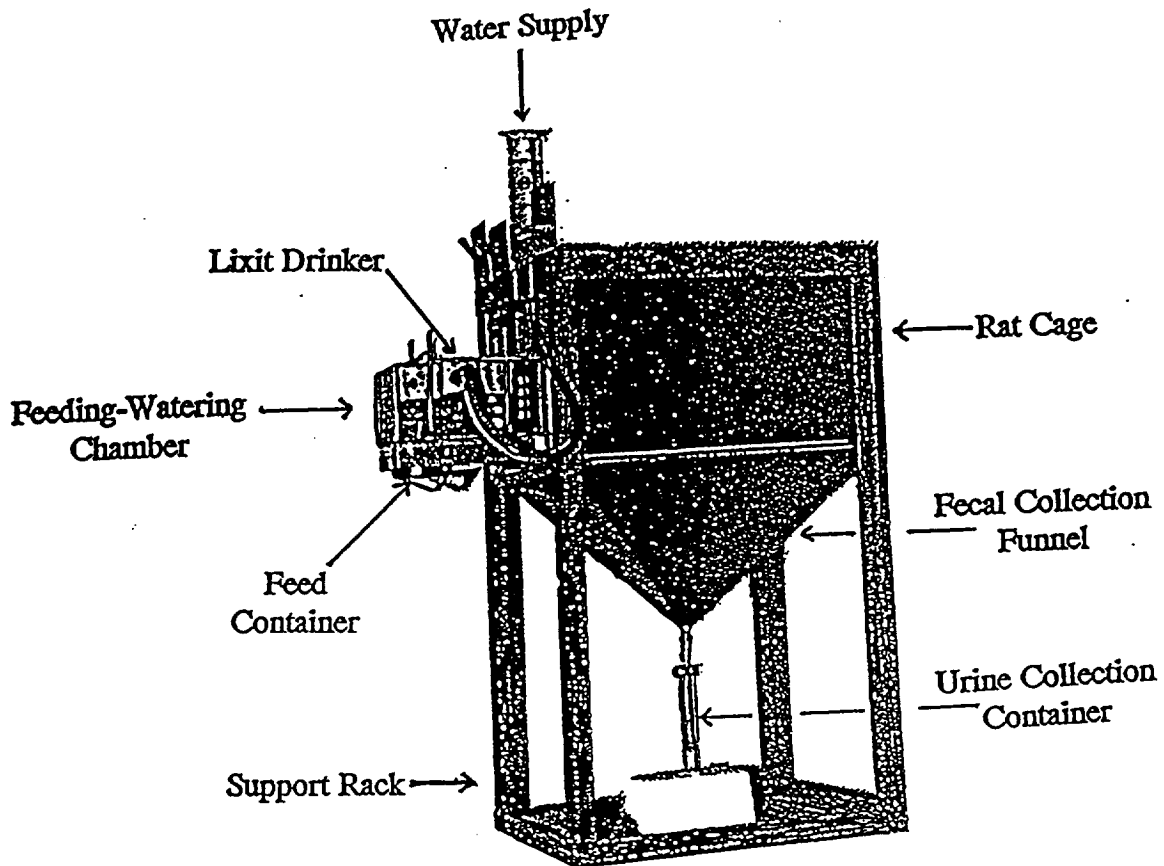

Figure S-6. Metabolism cage and support rack

