

NASA Contractor Report 4683

Pilot-Induced Oscillations and Human Dynamic Behavior

Duane T. McRuer

July 1995





NASA Contractor Report 4683

1N-08

44468

Pilot-Induced Oscillations and Human Dynamic Behavior

Duane T. McRuer
Systems Technology, Inc.
Hawthorne, California

Prepared under
Subcontract TSD-93-STI-2806
to PRC Inc.



National Aeronautics and
Space Administration

Office of Management

Scientific and Technical
Information Program

1995

TABLE OF CONTENTS

| | <u>Page</u> |
|--|-------------|
| LIST OF FIGURES | v |
| LIST OF TABLES | vii |
| ABSTRACT | 1 |
| INTRODUCTION | 2 |
| A. THE ANATOMY OF PILOT-INDUCED OSCILLATIONS | 3 |
| B. CLASSIC AND POTENTIAL FUTURE PIOS | 5 |
| C. PREDICTIVE MEANS AND CRITERIA | 6 |
| D. WHAT IS TO COME | 7 |
| HISTORICAL PERSPECTIVE | 8 |
| A. ESSENTIALLY SINGLE AXIS, EXTENDED RIGID BODY EFFECTIVE VEHICLE DYNAMICS | 8 |
| B. ESSENTIALLY SINGLE AXIS, EXTENDED RIGID BODY WITH SIGNIFICANT MANIPULATOR MECHANICAL CONTROL ELEMENTS | 11 |
| C. MULTIPLE AXIS PIOS EXTENDED RIGID BODY | 11 |
| D. PIOS INVOLVING HIGHER FREQUENCY MODES | 12 |
| PILOT BEHAVIORAL PATTERNS | 14 |
| A. HUMAN PILOT DYNAMICS — COMPENSATORY BEHAVIOR | 19 |
| B. HUMAN PILOT DYNAMICS — PURSUIT BEHAVIOR | 27 |
| C. HUMAN PILOT DYNAMICS — PRECOGNITIVE BEHAVIOR | 29 |
| D. PILOT ABERRANT BEHAVIOR CHARACTERISTICS | 32 |
| AIRCRAFT DYNAMIC FEATURES THAT CAN CONTRIBUTE TO PIO | 35 |
| A. EXCESSIVE LAGS IN EFFECTIVE VEHICLE (Aircraft Plus Stability Augmentation) | 35 |
| 1. Pilot Dynamic Characteristics in Severe PIOS | 37 |
| 2. Governing Principle for Good Flying Qualities — Tolerance to Pilot Compensation Variations | 53 |
| 3. The Space Shuttle Orbiter Approach and Landing Tests | 60 |
| 4. F-8 Digital Fly-by-Wire Experiments — The "Definitive" Lag Data | 62 |
| B. MISMATCHED PILOT-AIRCRAFT INTERFACE CHARACTERISTICS | 64 |
| C. CONTROLLER RATE LIMITING | 68 |
| D. VEHICLE DYNAMICS TRANSITIONS | 70 |
| 1. The YF-12 PIO | 70 |
| 2. T-38 PIO | 71 |
| TRIGGERS AS CENTRAL FEATURES IN SEVERE PIOS | 77 |
| SUGGESTED PILOT-BEHAVIOR-THEORY-BASED CATEGORIES FOR PIO | 79 |
| A. PROPOSED CATEGORIES | 79 |
| B. COMMENTARY | 80 |
| INTERIM PRESCRIPTIONS TO AVOID PIO | 83 |
| CONCLUDING REMARKS | 86 |
| REFERENCES | 89 |
| BIBLIOGRAPHY | 95 |

LIST OF FIGURES

| | <u>Page</u> |
|---|-------------|
| 1. Conditions Associated with PIO | 4 |
| 2. Human Dynamic Behavioral Features | 15 |
| 3. Additional Human Pilot Dynamic Features | 17 |
| 4. High Frequency PIO – Roll Ratchet (Adapted from Refs. 38, 59) | 18 |
| 5. Simple Compensatory System and Time Responses (Adapted from Ref. 48) | 20 |
| 6. Crossover Model for Compensatory Systems (Adapted from Refs. 48, 60) | 21 |
| 7a. Bode Diagrams for Crossover Model | 24 |
| 7b. Gain-Phase Diagram for Crossover Model | 25 |
| 8. Closed-Loop Pilot-Vehicle System Possibilities (Compensatory and Pursuit) | 28 |
| 9. Comparative Data for Pursuit and Compensatory Conditions (Adapted from Ref. 51) | 29 |
| 10. Sources of Pilot-Induced Oscillations (Pilot Aberrant-Behavior Characteristics) | 33 |
| 11. Sources of Pilot-Induced Oscillations (Aircraft Dynamic Characteristics) | 36 |
| 12a. PIO Rating Scale and Flowchart | 38 |
| 12b. Cooper-Harper Pilot Rating Scale | 39 |
| 13a. Baseline Configuration: 2-1 Pilot Ratings: 2/2/3 ; PIOR: 1/1/1 ; $\tau_p = 0.054$ sec Incremental Gain Range = 15.96 dB (6.28) | 41 |
| 13b. Configuration: 2-5 {2-1 * 1/(1)} Pilot Ratings: 10/7/10 ; PIOR: 4/4/5 ; $\tau_p = 0.235$ sec Incremental Gain Range = 9.40 dB (2.95) | 42 |
| 13c. Configuration: 2-8 {2-1 * 1/[.7,9]} Pilot Ratings: 8/10/8 ; PIOR: 4/4/4 ; $\tau_p = 0.19$ sec Incremental Gain Range = 6.60 dB (2.14) | 43 |
| 13d. Baseline Configuration: 3-1 Pilot Ratings: 5/3/4 ; PIOR: 3/2/2 ; $\tau_p = 0.059$ sec Incremental Gain Range = 16.37 dB (6.58) | 44 |
| 13e. Configuration: 3-12 {3-1 * 1/[.7,2]} Pilot Ratings: 7/9 ; PIOR: 4/5 ; $\tau_p = 0.32$ sec Incremental Gain Range = 5.32 dB (1.84) | 45 |
| 13f. Configuration: 3-13 {3-1 * 1/[.7,3]} Pilot Ratings: 10/10 ; PIOR: 4/5 ; $\tau_p = 0.28$ Incremental Gain Range = 5.48 dB (1.88) | 46 |
| 13g. Baseline Configuration: 5-1 ; Pilot Ratings: 2/5 ; PIOR: 1/1 ; $\tau_p = 0.053$ sec Incremental Gain Range = 18.71 dB (8.62) | 47 |

LIST OF FIGURES (concluded)

| | <u>Page</u> |
|--|-------------|
| 13h. Configuration: 5-9 {5-1 * 1/[.7,6]} Pilot Ratings: 7/7 ; PIOR: 4/4 ; $\tau_p = 0.26$ sec Incremental Gain Range = 7.09 dB (2.26) | 48 |
| 13i. Configuration: 5-10 {5-1 * 1/[.7,4]} Pilot Ratings: 10/10 ; PIOR: 5/5 ; $\tau_p = 0.36$ sec Incremental Gain Range: 4.76 dB (1.73) | 49 |
| 14. Comparison of Flight-Based PIO Frequencies with Neutral Stability of θ/F_s | 51 |
| 15. Comparison of Flight-Based PIO Frequencies with Compensatory System Resonant Frequencies | 52 |
| 16. Comparison of Flight-Based PIO Frequencies with Compensatory System Neutral Stability Frequency Based on the Crossover Model | 53 |
| 17. Bode and Gain Phase/Nichols Plots for LAHOS Case 2-C | 56 |
| 18. Bode and Gain Phase/Nichols Plots for LAHOS Case 2-10 | 57 |
| 19. Shuttle Orbiter PIO (Ref. 18) | 61 |
| 20. Effective Time Delay Data from Flight and Simulators (Ref. 77) | 62 |
| 21. Flight Recording of F-8 DFBW PIO (NASA Ames/Dryden Flight Research Facility) | 63 |
| 22. Pilot Ratings vs. Controlled Element Gain (Ref. 46) | 65 |
| 23. Real World Complications Associated with PIO Understanding and Assessments | 67 |
| 24. Simplified Surface Servoactuator System | 69 |
| 25. Large-Amplitude YF-12 PIO Time History (Ref. 15) | 71 |
| 26. Bode Diagram of YF-12 Longitudinal Control System and θ/δ_{ep} Describing Functions (Adapted from Ref. 15) | 72 |
| 27. Flight Recording of T-38 PIO (Adapted from Refs. 10, 29, 30) | 73 |
| 28. T-38 Primary Control System Block Diagram (Ref. 10) | 75 |
| 29. Effect of Bobweight on Pitch Response (Ref. 10) | 76 |
| 30. Precursors/Triggers Mechanisms/Pilot Mode Shifters | 78 |
| 31. Interim Prescriptions for Reduction of PIO Potential | 84 |

LIST OF TABLES

| | <u>Page</u> |
|---|-------------|
| 1. Famous PIOs | 9 |
| 2. Crossover Model Characteristics for Idealized Controlled Elements | 27 |
| 3. Closed-Loop Characteristics for Synchronous Pilot and Idealized Rate-Command Controlled Elements | 31 |
| 4. Bjorkman Configurations with Severe PIO's | 40 |
| 5. Severe PIO Frequencies Developed From Bjorkman Data (Ref. 72) with Corresponding Values of ω_{u_θ} and ω_R | 50 |
| 6. Severe PIO Subset with Crossover Model | 52 |
| 7. Some Summary Measures of Frequency Domain Characteristics | 59 |

ABSTRACT

This is an in-depth survey and study of Pilot-Induced Oscillations (PIOs) as interactions between human pilot and vehicle dynamics; it includes a broad and comprehensive theory of PIOs. A historical perspective provides examples of the diversity of PIOs in terms of control axes and oscillation frequencies. The constituents involved in PIO phenomena, including effective aircraft dynamics, human pilot dynamic behavior patterns, and triggering precursor events, are examined in detail as the structural elements interacting to produce severe pilot-induced oscillations. The great diversity of human pilot response patterns, excessive lags and/or inappropriate gain in effective aircraft dynamics, and transitions in either the human or effective aircraft dynamics are among the key sources implicated as factors in severe PIOs. The great variety of interactions which may result in severe PIOs is illustrated by examples drawn from famous PIOs. These are generalized under a pilot-behavior-theory-based set of categories proposed as a classification scheme pertinent to a theory of PIOs. Finally, a series of interim prescriptions to avoid PIO is provided.

SECTION I

INTRODUCTION

A pilot-induced oscillation (PIO) is an inadvertent, sustained aircraft oscillation which is the consequence of an abnormal joint enterprise between the aircraft and the pilot. In one form or another these fascinating and complex pilot-vehicle interactions have been around since the Wright Brothers. They thus have an unambiguous status as THE senior flying qualities problem or, more precisely, problems. For, as one kind of PIO appears (almost invariably surreptitiously), it stirs actions which are more or less corrective and generally useful for the future in that the major sources believed to cause the particular difficulty tend to be avoided in later aircraft (not always, of course, because the "word" never seems to spread to all that should hear!). Then, with different circumstances, another kind of PIO repeats the cycle. The fact of oscillation itself is the constant in this progression; the details shift with the flight control system technology employed.

The state of affairs outlined above has existed for several decades, with only very occasional attempts at general advances. These were often spasmodic and ad hoc, tending to be associated with specific problems encountered in flight. Recently, however, there has been a confluence of some highly visible accidents in both military and civil craft (e.g., the YF-22, JAS 39, and MD-11 PIOs), and incidents (e.g., V-22 and C-17 pilot-vehicle oscillations), which has captured attention of policy-makers, decision-makers, and applied research engineers and scientists. Besides ad hoc efforts aimed at correcting the specific problems, another round of general activities is now underway. These have three foci, which have different time scales and breadth. The first is narrowly confined to reduce PIO potential by current "legislative means," i.e., by setting forth criteria, e.g., Refs. 1, 2, 3, and 4, based on existing predictive concepts such as Refs. 5, 6, 7, and 8. The second focus emphasizes corrective approaches, e.g., Ref. 9. The third is more general in that it recognizes the paramount need for an enhanced quantitative analytical understanding of PIOs, embodied in a theory or theories of those pilot-vehicle interactions which underlie PIOs. An adequate PIO theory which improves and codifies understanding can be useful in "explaining" existing PIOs and in the validation of existing concepts and criteria which are consistent with actual PIO and related data; they can also lead to the development of new concepts, appropriate criteria, and superior flying qualities design. This is the subject addressed in this report.*

Pilot-vehicle oscillatory phenomena comprise a complete spectrum. The oscillation may be a very temporary, easily-corrected, low-amplitude bobble often encountered by pilots when getting the feel of and used to a new configuration — basically a learning experience. This can happen on every airplane,

*This report is a much extended version of the Twenty-Second Minta Martin Lecture, "Human Dynamics and Pilot-Induced Oscillations," given by the author on 2 December 1992 while at the Massachusetts Institute of Technology as the Jerome Clarke Hunsaker Professor of Aeronautical Engineering.

and has undoubtedly been experienced by every pilot at one time or another. On the other hand, a fully-developed, large amplitude oscillation with near or actual catastrophic consequences is a chilling and terrifying event jeopardizing the safety of the aircraft and crew. The only good thing about severe PIOs is that they are very rare.

Yet severe PIOs persist and, in fact, grow in variety and complexity as aircraft systems otherwise advance. The large amplitude, potentially catastrophic, severe PIO can appear in many guises and can involve many diverse factors which tend to complicate and confuse. The nature of these factors and how they interact to produce severe PIOs needs to be understood; the goal of this report is to define a current status in satisfying this need. The approach taken here is to identify, describe, and examine the constituents of severe PIOs and how they may interact to create PIO phenomena. Ideally this would result in a comprehensive quantitative understanding of severe PIOs which elucidates their individual and interactive mechanisms.

A. THE ANATOMY OF PILOT-INDUCED OSCILLATIONS

PIO is a collaboration between the pilot and the airplane in that the oscillations can occur only when the pilot attempts to impose his will on the aircraft. Indeed the aircraft left to its own devices may be stable. Because the pilot's actions depend in part on the motions of the airplane in response to pilot commands, the aircraft and pilot dynamics form a closed-loop feedback control system. The pilot is said to be "operating closed-loop" or to be "in the loop." The oscillations can therefore be identified as closed-loop instabilities of a feedback control system.

The general physical structure of the pilot-vehicle system and the necessary and sufficient conditions for oscillation are summarized in Figure 1 for single-loop situations. Generally, "single-loop" may include all situations where the pilot's output is expressed by a single manipulation of a control inceptor (which may effect several vehicle control effectors, as with coordinated motions of aileron and rudder originated by a lateral stick deflection). Similarly, "single-loop" includes many multi-variable-input situations. The pilot's input can be: a simple visual cue, such as pitch attitude; motion cue, such as normal acceleration at the pilot's location; or a composite signal, such as a flight-director error display. Thus the "single-loop" situations defined here really refers to the solitary character of the pilot's control output, c , in Figure 1.

The sufficient conditions can only be satisfied when the pilot-vehicle system is operating with high loop gains. Figure 1 lists some flight control tasks in which a high open-loop system gain may be required to achieve desired closed-loop system performance. Most of these high pilot gain tasks are well-defined flight operations. These nominal high gain tasks are normal and ordinary, whereas severe PIOs are extraordinary events. Thus, while some PIOs may occasionally appear as the result of over-aggressive actions, they can usually be associated with abnormal changes in the pilot's and/or the effective vehicle dynamics. This is where the last item listed, in Figure 1, "Demanding/Unexpected Transitions," comes in. These include

ELEMENTARY PILOT-VEHICLE FEEDBACK SYSTEM

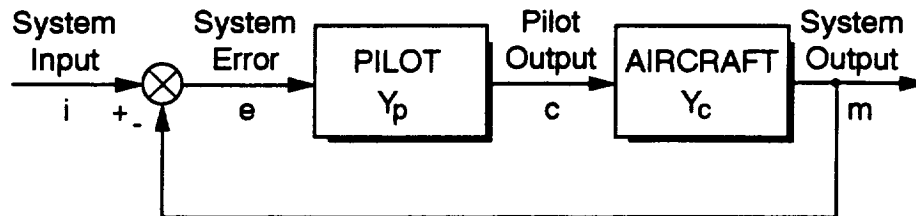

NECESSARY AND SUFFICIENT CONDITION FOR INSTABILITY

Full Attention -- Transfer Characteristics of Pilot + Effective Aircraft, $Y_p Y_c = -1$

USUAL CONDITIONS OF ONSET

High Gain/Task Urgency -- Often with a Precursor Trigger

TYPICAL TRACKING TASKS WITH HIGH PILOT GAIN/URGENCY

Aerial Refueling

Formation Flying

Precision Tracking

Precision Approaches and Spot Landings (e.g., carrier approach)

Terrain Following

Demanding/Unexpected Transitions

Figure 1. Conditions Associated with PIO

conditions inducing or requiring: 1) major and sudden overall pilot-vehicle system configuration changes, e.g., wave offs, target maneuvering, shifts in goals, etc.; 2) effective vehicle configuration modifications e.g., sudden changes in effective aircraft dynamics — such as low-altitude cargo extractions, afterburner light-off, engine unstart, stability augments failure, asymmetric stores release, or amplitude-sensitive vehicle dynamics changes driven by pilot output-amplitude shifts from small to large, or 3) changes in the pilot's dynamics and/or the pilot-defined system architecture, e.g., shifting of attention or dominant cues, etc.

The unexpected and unusual aspect of most severe PIOs implies the likely presence of another unusual precursor or trigger event, arising from either external or internal origins. These may be conditions of major upset, which can stem from gusts, turbulence, unexpected events (e.g., runway incursions), etc. which enter from the external environment. Triggers may also derive from transitional changes in the pilot's or effective vehicle's characteristics, i.e., transitions in the system or system elements themselves may actually embody triggering events as well as dynamic changes.

These anatomical elements involved in the generation of PIOs are examined, along with key interactions, in three sections of this report: pilot dynamic behavior patterns and possible transitions between these patterns; effective aircraft dynamic features; and triggering possibilities. The PIO-sensitive dynamic attributes of the first two are developed both as individual system elements, and as interactive partners within the system. As the interacting entities they are key to PIO understanding and possible nature — the omnipresent essential ingredients. These are sufficient to discover what is possible, although not the specifics of exposure and potential. The triggering possibilities, on the other hand, are almost impossible to encompass in general; we can only provide examples of past PIO precursors, so one can then attempt to project from these experiences some of the conceivable triggers for specific new situations.

B. CLASSIC AND POTENTIAL FUTURE PIOS

Many classic severe PIOs can be understood in the context of quasilinear system considerations. While PIOs often start with fairly low amplitudes, which can adequately be treated with small perturbation linear theory, severe PIOs will, by definition, become very large. In the fully-developed state these can still be treated on a quasi-linear basis, including the impact on closed-loop piloted control of such nonlinear features as actuator rate and surface position limiting, hysteresis, etc. When these combine, a severe PIO, when it is encountered, becomes harder to unravel and to understand in its details. In fact, the majority of the severe PIO time history records available show surface rate limiting (and sometimes stick or surface position limiting as well) in the fully developed oscillation. Particularly insidious nonlinearities lead to combinations of actuator rate limiting, surface and/or SAS position limits, nonlinear stick shaping of pilot commands, various fader combinations, etc. which interact to create a confounding variety of input-amplitude-sensitive effective vehicle dynamics.

Unfortunately, future advanced systems promise to be even more arcane. Advanced aircraft which apply active control principles to multiple control effectors (e.g., combinations of canards, flaps, elevons, thrust vectoring, etc.) complicate the flying qualities and potential PIO pictures by creating a large number of effective vehicle dynamic possibilities which can be recruited at will or, sometimes, inadvertently. While enhancing nominal dynamic performance, such systems may also introduce new PIO possibilities associated with transitions in effective vehicle dynamics as functions of the flight control system state or of the pilot's input amplitude. Thus, increases in flight control system complexity introduced to improve overall system performance are accompanied by an increase in the number of transitions possible, a number that is already quite large.

C. PREDICTIVE MEANS AND CRITERIA

No one ever designs an airplane to be PIO-prone, and their presence is never welcome! They can be pernicious because of their unpredictability. Manned simulations, either ground- or in-flight-based, have been historically unable to guarantee their likely presence or absence. Further, existing and proposed criteria are similarly insufficient in many respects. Considered in their most general sense, most existing criteria emphasize the importance of net high-frequency lags as major factors in PIO. These can indeed be major contributors to poor flying qualities, and they are inconsistent with the ability to exert precise, high gain, closed-loop control. But detailed investigations of the causes of specific severe PIOs reveal that additional factors are often needed to explain the phenomena, especially for the severe PIOs of most interest here. As none of these factors are specifically contained in the existing or proposed criteria they can be incomplete at best, and non-selective at worst.

Although the assessment of aircraft for PIO tendencies using existing predictive criteria, simulations and testing procedures is not yet sufficient to cover all cases, this status is a powerful motivation for improvement. In particular, the unappreciated and ill-defined factors associated with PIO possibilities, and the current incomplete understanding of PIO mechanisms, further underscore the paramount need for an enhanced quantitative understanding of PIOs — comprehensive experiments, analyses, and theories of PIO suitable to cover both classic and future situations. In the normal course, theoretical concepts which improve and codify understanding will support the development of new concepts, appropriate adjustments of criteria to fit new systems, and superior flying qualities design. This is a consummation devoutly to be wished, so a major thrust of this report is to advance the development of a comprehensive theory of severe pilot-induced oscillations which can be used in company with existing criteria and ground and in-flight simulations to address future advanced aircraft and/or to assess and help alleviate PIO problems with existing aircraft as they appear. It is not, however, the purpose to explore existing criteria or PIO testing procedures in depth, or to add to the list in either area.

D. WHAT IS TO COME

The next section provides a historical perspective based on "Famous PIOs," notorious but celebrated as significant events in aviation history which had to be surmounted. A very few of these PIOs have been extensively measured and analyzed and have details which are well-appreciated. Others are represented primarily by gradually fading movie or video recordings; while still others are becoming part of the lore, even mythology, of flight. They are or were all important in the sense of providing lessons to be learned and behavior to be explained.

The third section describes pilot behavioral patterns. In some respects, the appellation "Pilot-Induced Oscillations" is pejorative because the pilot acting alone is seldom the problem. Because the phrase tends to raise emotional hackles or, more importantly, to shift blame from the machine to the pilot, some investigators prefer to speak of "Aircraft-Pilot Coupling" or "Pilot-Augmented Oscillations," etc. Regardless, the fact remains that the pilot is a participant, and pilot behavior is the source-factor which distinguishes the severe PIO problem from most aircraft feedback control design problems. The differences reside in those uniquely human properties related to the enormously adaptive characteristics of the human pilot for which there are no parallels in an automatic flight control system. First, different pilot behavior patterns are associated with different types of PIO. These patterns include: compensatory behavior and low-frequency neuromuscular dynamics with PIOs in the 0.3 to 0.8 Hz (2-5 rad/sec) range; synchronous pilot dynamics with PIOs in the 1-2 Hz (6-12 rad/sec) range and with flexible mode interactions, more complete limb/neuromuscular/manipulator dynamics with PIOs in the 1-3 Hz (6-20 rad/sec) range, etc. Second, pilots exhibit peculiar transitions in the organizational structure of the pilot-vehicle system. These transitions can involve both the pilot's compensation (e.g., when a pilot adapted to high-gain compensatory tracking/regulation suddenly shifts to a "synchronous" pure gain mode) and the effective architecture of the pilot's control strategy (i.e., as manifested by which variables the pilot senses and processes). All of these and other PIO-significant aspects of pilot dynamics are covered in the "Pilot Behavioral Patterns" section.

The fourth section turns to the other partner — aircraft dynamic features which can contribute to a PIO. These are very extensive, and the section is the longest in the report by far. Both experimental studies and examples from the "Famous PIOs" series are examined for what they can tell us about the effective aircraft's role.

The third constituent in the anatomy of PIOs are triggers or precursors. These are idiosyncratic and difficult to generalize, so they are covered in the fifth section mainly by listing examples.

The remaining sections of the report are devoted to a proposed classification scheme for PIOs, a short section giving some interim prescriptions to avoid PIO, and concluding remarks.

SECTION II
HISTORICAL PERSPECTIVE

A study of aeronautical history reveals a remarkably diverse set of severe PIOs. Although we will later propose a different classification scheme for PIOs, it is useful here to group the varieties by focusing on two primary features: the number of aircraft control axes which are fundamentally involved; and the frequency of the closed-loop aircraft-pilot couplings, which can range from about 1/2 to 3 Hz. These distinguishing features serve to divide PIOs into four different groups. Each group is exemplified by well-known incidents of aircraft-pilot couplings, all notable or even celebrated, and some catastrophic. These are summarized in Table 1 — "FAMOUS PIOs." (The reader is also referred to Table 1 — "Classification of Some Known PIO Cases" of Ref. 10, for really old PIOs!). Appropriate references, when available, are given in Table 1, although for many of the PIOs there is little or no data available other than movies or personal recollections from witnesses. However, for some of these flight test records may still be in some obscure archive which has escaped the author's searches. The "Category I, II or III" notations refer to the PIO classification scheme proposed later (Section VI).

A. ESSENTIALLY SINGLE AXIS, EXTENDED RIGID BODY EFFECTIVE VEHICLE DYNAMICS

Most of the PIO research to date has been focused on effective aircraft dynamics which are characteristic of rigid body longitudinal or lateral-directional properties. Higher frequency dynamics representing the control actuators, effects of SAS dynamics, digital system time delays, etc. have been incorporated, usually approximated as parts of an effective time delay. For many PIOs such approximations are both appropriate and adequate. Specific examples of severe PIOs where the key effective vehicle dynamics are of this "extended rigid-body" variety include the Table 1 entries for: "Longitudinal PIOs — Extended Rigid-Body," and "Lateral-Directional PIOs — Extended Rigid-Body."

Perhaps best known and surely the most widely viewed lateral PIO in this category was the remarkable unintended "first flight" of the YF-16. A description of the participating events is given in Ref. 11. The longitudinal variety have several dramatic entries — including the Shuttle Orbiter ALT-5 and the tragic F-4 record run. (Videos of these and several others exist and are recommended viewing for serious students of PIO phenomena.)

TABLE 1. FAMOUS PIOS

Longitudinal PIOS — Extended Rigid-Body

| | |
|----------------------|--|
| XS-1 | PIO during gliding approach and landing, 24 Oct 1947; NACA pilot Herbert Hoover (Ref. 12) |
| XF-89A | PIO during level off from dive recovery, early 1949; pilot Fred Bretcher |
| F-86D | PIO during formation flying when pulling G's |
| F-100 | PIO during tight maneuvering |
| F-101 | Aft CG |
| X-15 | Gliding flight approach and landing, 8 June 1959; pilot Scott Crossfield; (Ref.s. 13, 14; PIO Analysis in Ref. 10); Category II PIO |
| XF2Y-1 (Sea Dart) | Post-takeoff destructive PIO |
| YF-12 | Mid-frequency severe PIO (Refs. 15, 16); Category III PIO |
| MRCA | Short Take-off, 1975; Heavy Landing, 1976 |
| Shuttle | ALT-5 during landing approach glide, 26 Oct 1977; pilot Fred Haise; both attitude and path modes involved; (Refs. 17, 18); Category II PIO |
| DFBW F-8 | PIO during touch and goes, 18 April 1978; pilot John Manke (Ref. 19); Category III PIO |
| YF-22 | PIO after touchdown and wave off in afterburner, 25 April 1992; pilot Thomas Morgenfeld (Ref. 20); Category III PIO |
| JAS 39 | PIOs during approach, 1990; 1993; Category II — III PIOS |
| MD-11 | China Eastern Airlines FLT 583, 6 April 1993; Inadvertent slat deployment (Ref. 21) |

Lateral-Directional PIOS — Extended Rigid-Body

| | |
|---------|---|
| KC-135A | Mild Lateral-directional PIO associated with ω_ϕ/ω_d , effects, late 1950's (Ref. 22) |
| B-52 | Roll PIO while refueling |
| F-101B | Lateral PIO at high q subsonic (Ref. 23) |
| X-15 | Lateral PIO, ω_ϕ/ω_d , Research Study, 1961 (Ref. 24) |
| Parasev | Paraglider Research Vehicle lateral rocking PIO during ground tow, 1962; pilot Bruce Peterson (Ref. 12) |

TABLE 1. FAMOUS PIOS (concluded)

| | |
|--|--|
| B-58 | Lateral-directional control-associated crash, Sept 14, 1962; pilot Ray Tenhoff |
| M2-F2 | Lifting Body Lateral-directional PIO, first on 10 May 1967; pilot Bruce Peterson (Refs. 25, 26); Category II PIOS |
| YF-16 | "First Flight," pilot Phil Oestricher (Refs. 11, 26); Category III PIO |
| <u>Longitudinal PIOS — Extended Rigid Body Plus Mechanical Elaborations</u> | |
| A4D-2 | High speed PIO, during routine flight testing, 19 January 1957 (Refs. 27, 28); Bobweight and Primary control system involved; Category III PIO |
| T-38 | High Speed PIO, 26 Jan 1960; (Refs. 10, 16, 29, 30, 31, 32); distributed Bobweight and Primary control system involved; Category III PIO |
| F-4 | Low altitude record run second pass, 18 May 1961; pilot Cmdr Jack Feldman; destructive PIO |
| <u>Lateral-Directional PIOS — Extended Rigid Body Plus Mechanical Elaborations</u> | |
| A-6 | Lateral effective bobweight effects; Category I PIO |
| <u>PIOS Associated with Higher-Frequency Non-Rigid Body Modes</u> | |
| YF-12 | High-frequency flexible mode involvement (Refs. 15, 16); Category I PIO |
| CH-53E | Airplane-Pilot Coupling with Flexible Modes, several major instances in precision hover and with heavy sling loads, including heavy landings, dropped loads, etc., 1978 – 1985 (Refs. 33-35); Extreme Category I to Category II PIOS |
| F-111 | Pilot Lateral Control coupling with sustained underwing heavy store limit cycle oscillation (Ref. 36) |
| Voyager | Pilot Coupling with Symmetric Wing Bending, 1986 (Ref. 36) |
| V-22 | Pilot involvement with: a) 1.4 Hz lateral oscillation on the landing gear; b) 3.4 Hz antisymmetric mode destabilized by pilot aileron control; c) 4.2 Hz symmetric mode destabilized by pilot collective control (Ref. 37) |
| <u>3-D, Multi-Axis PIOS</u> | |
| X-5 | 31 March 1952, pilot Joe Walker (Ref. 12) |
| Shuttle | ALT-5 Lateral PIO, just prior to longitudinal PIO described in Refs. 18, 11; Oct. 1967, pilot Fred Haise |
| F-14 | High α , with some β ; pilot Don Evans |
| AD-1 | Oblique Wing |

B. ESSENTIALLY SINGLE AXIS, EXTENDED RIGID BODY WITH SIGNIFICANT MANIPULATOR MECHANICAL CONTROL ELEMENTS

PIOs in this group are similar to those described above, with the addition that the primary mechanical control system plays a major role. The aircraft included are of more traditional design, and typically incorporate such elements as single or dual bobweights, various artificial feel devices, etc. Some older aircraft or modern aircraft with simpler primary controls have tab or servo-tab controls, power boost rather than fully powered surface actuators, etc. System friction and hysteresis effects can be very important, since they tend to create two different sets of effective airplane dynamics (e.g., corresponding to small-amplitude and large-amplitude pilot inputs). In these systems the aircraft dynamics are still extended rigid body, but the dynamics of the primary control and artificial feel system also contribute. In the simplest situations, the effective airplane dynamics differ primarily as a function of the pilot's output amplitude (e.g., the T-38 PIO of Ref. 10 or the YF-12 PIO of Ref. 15), and the pilot's inability to adapt to large changes from pre- to post-transition effective airplane dynamics is central to the PIO. In some cases the limb-neuromuscular-manipulator system dynamics are major factors, either as a simple effective limb bobweight, or as a much more elaborate dynamic entity. Severe PIO examples in this category listed in Table 1 include "Longitudinal PIOs - Extended Rigid Body Plus Mechanical Elaborations" and "Lateral-Directional PIOs - Extended Rigid Body Plus Mechanical Elaborations."

C. MULTIPLE AXIS PIOS EXTENDED RIGID BODY

Of all the essentially rigid body PIOs these are by far the most interesting, dramatic, and least well understood. Some appreciation can be gained by a Joe Walker test report on an exciting flight with the X-5 airplane (Ref. 12):

"As the airplane pitches, it yaws to the right and causes the airplane to roll to the right. At this stage aileron reversal occurs, the stick jerks to the right and kicks back and forth from neutral to full right deflection if not restrained. It seems that the airplane goes longitudinally, directionally, and laterally unstable in that order."

As noted by Einar Enevoldson, a noted retired NASA Dryden test pilot, "3-D PIOs are extreme, and are present in many aircraft under asymmetric conditions. Besides the oblique wing AD-1, another example was a 3-D PIO in an F-14 at high angle of attack and large sideslip, which resulted in a departure which was very difficult to recover." Thrust-vectoring aircraft, damaged aircraft, and aircraft with asymmetrically-hung stores, are also subject to unusual asymmetries. Unfortunately, this PIO type is not at all well understood. For aircraft with elevon or ailevator controls, which can create conflicts between axes, the multi-axis PIO phenomenon can be further complicated by position as well as rate limiting.

D. PIOS INVOLVING HIGHER FREQUENCY MODES

A downside of the trend for more highly integrated aircraft, and especially aircraft that are flown unstable, is the insurgence of the lower frequency flexible modes into the frequency range of stability augmentation and pilot control. For these vehicles the extended rigid body characteristics are not sufficient or, sometimes, even relevant. Instead, the lower frequency flexible modes enter and the pilot's neuromuscular dynamics play key roles.

Cases in which the limb-neuromuscular dynamics are central to pilot-vehicle oscillations are fairly common even with extended rigid body or extended rigid body plus mechanical controls. The roll ratchet phenomenon is a notable example (e.g., Refs 38, 39, and 40). Here the characteristic frequency is set primarily by the limb-manipulator combination, tending to range from 2 - 3 Hz. To the extent that this type of PIO is a limb-bobweight phenomenon it is sometimes referred to as Pilot-Augmented Oscillation (PAO). PAO is probably not catastrophic in the safety sense, although it can severely limit the airplane's maneuvering performance. Roll ratchet cases are not included in Table 1, although some of the aircraft listed there have exhibited the characteristic.

Pilot interaction with lower frequency flexible modes can be extremely severe. As reported in Ref. 36 they have been observed on the F-111 at the edges of its flight envelope when loaded with heavy stores, and with the Rutan Voyager. Of the documented cases to date, the flexible mode coupling observed on the YF-12 (Ref. 15) was relatively mild while the CH-53 was quite the opposite. In fact, the pilot-vehicle interactions encountered with the CH-53E helicopter are extremely important harbingers of things to come as flexible modes become significant elements in aircraft-pilot coupling. They are of particular future concern in connection with large, flexible aircraft such as the National Aerospace Plane (NASP) (Refs. 41, 42), and may be prominent in the High Speed Civil Transport (Ref. 43).

In connection with the CH-53E, the severe pilot-aircraft oscillations that occurred were associated with the lower flexible mode frequencies. These were first encountered with the aircraft in precision hover tasks. They were particularly severe when large sling loads were present. The extra dynamics due to the sling load were not an important feature of these oscillations, but the much higher sensitivity to cyclic controls associated with the increased collective needed to support the load was. Several dramatic incidents which occurred over a period of years (1978 - 85), including some high-visibility events in which catastrophe was avoided only by dropping the load (in one case a light armored vehicle), created a great deal of high level attention in the US Navy. The very comprehensive analysis, flight, and ground test program conducted to define and measure all the dynamics and conditions involved (Refs. 33-35) make this an unusually well-documented case study.

As further noted in Table 1, the CH-53E is not alone among rotorcraft for PIO or PAO. The V-22 tiltrotor aircraft experienced three incidents of this nature in flight test operations (Ref. 37). The first was a 1.4 Hz lateral oscillation on the landing gear, the second a 3.4 Hz antisymmetric mode destabilized by pilot/lateral control stick coupling, and the third was a 4.2 Hz symmetric mode destabilized through pilot collective control inputs.

SECTION III

PILOT BEHAVIORAL PATTERNS

A significant attribute of a human pilot is the ability to establish a wide variety of pilot-vehicle system organizations (Refs. 44, 45, 46, 47, 48, 49). In essence, human adaptive and learning attributes permit the pilot to be simultaneously engaged as the on-going architect and modifier of the pilot-aircraft system itself and as an operating entity within that system. As the pilot "changes" the system organization, the pilot's dynamic behavior is adjusted as appropriate for the overall system. This repertory of behavior is so extensive that the pilot, as a learning and adaptive controller operating with an extensive array of endogenous sensing mechanisms, has capabilities which far exceed those of the most sophisticated unmanned control system.

From the system analysis standpoint this variety is, at first, disconcerting. For many flight control situations, however, the complexities exhibit an orderly character — evolutionary forces have worked to the analyst's great advantage! In controlling any complex system operating at or near its margins, *successful* behavior is very narrowly limited. The very nature of the requirements for "good" system performance and the restrictions imposed by the dynamic characteristics of the aircraft constrain the successful human pilot to operate in accordance with well-established "behavioral laws." When well-trained and motivated, and when the restrictions imposed on pilot-vehicle system performance are severe, the performance of the pilot and the system can be predicted in both qualitative and quantitative terms — in short the pilot-vehicle system is amenable to mathematical analysis like inanimate systems (Ref. 48). Operationally, each of the pilot-organized system structures can be depicted as an effective pilot-vehicle system block diagram which corresponds to a "control law." Feedback control system analysis principles can be extended to treat these pilot-vehicle systems. The dynamic behavior of human pilots can be described and quantified by "describing functions," which are akin to the transfer functions used to characterize the airplane dynamics, and an additive pilot-induced noise or "remnant."

The overall result of all this versatility is a variably-configured, task-oriented, pilot-vehicle system which in any of its manifestations is ordinarily admirably suited to accomplish flight control goals with great efficiency and precision. On occasion, however, aberrations in either the pilot's system organization or dynamic behavior appear which induce far from ideal system behavior. PIOs are a notable example.

There are several behavioral modes or patterns which can conceivably enter into or influence pilot-induced oscillations. These are cataloged in Figure 2. The "Control Architectural Patterns" are names for particular types of pilot-vehicle system structure; each can be represented as a specific block diagram showing the essential control pathways which embody that structural form. For example, in "Compensatory" behavior the pilot responds primarily to errors in the pilot-vehicle system, as in Figure 1. The dynamic properties for some of these behavioral patterns will be described later. In principle these

FULL-ATTENTION CONTROL ARCHITECTURAL PATTERNS

Compensatory -- Pilot Response Conditioned on Errors

Pursuit -- Response Conditioned on Errors + System
Inputs and Outputs

Pursuit with Preview -- Preview of Input Added

Precognitive -- Skilled, Essentially Open-Loop

Precognitive/Compensatory -- Dual Mode Control

BEHAVIOR TRANSITIONS

Successive Organization of Perception (SOP)

Shift in pilot-organized control system architecture

SOP progressive transitions

compensatory

pursuit

precognitive/compensatory

precognitive

SOP regressive transitions

Controlled-Element-Induced Transitions

Post-transition retention

Post-transition re-adaptation

Figure 2. Human Dynamic Behavioral Features

modes can exist for a variety of pilot percepts, although visual and acceleration cues are certainly dominant in flight control.

The second major heading in Figure 2 lists the types of transitions among the behavioral patterns which can sometimes occur (Refs. 45, 46, 50, 51, 52). The "SOP Progressive Transitions" form a sequence, based on the Successive Organization of Perception (SOP) theory (Refs. 45, 46, 48). As the system structure established by the pilot changes progressively, overall pilot-vehicle performance improves. Specifically:

- closed-loop system effective bandwidth increases;
- system dynamic response is faster, with less error;
- pilot workload is reduced.

The "SOP Regressive Transitions" proceed in the opposite direction.

Also in Figure 2 are the consequences on the pilot dynamics of sudden or step-like changes in the effective vehicle dynamics. The "Post Transition Retention" phase (Ref. 48) covers a time period immediately after a sudden change in vehicle characteristics. During this interval the pilot dynamics remain those adapted to the vehicle dynamics which were present before the change. This phase is followed by adaptation to the post-transition aircraft dynamics.

The basic behavioral modes called out in Figure 2 pertain to the fundamental human pilot dynamic forms for conditions when the pilot is devoting full attention to control tasks. Figure 3 completes the dynamic features summary list. The first item, divided attention phenomena, is important for many flying tasks, but is seldom pertinent to PIOs because they are invariably full-attention in the developed state. (Reduction in divided attention, as in the narrowing of the attentional field, with a consequent increased focus on a dominant control variable and increased pilot gain, can be a precursor and initiating facet for a PIO.) On the other hand, the neuromuscular system dynamics and the acceleration feedthroughs can be important factors in pilot-aircraft oscillations (Refs. 38, 39, 53-58). An example of a high-frequency (2-3 Hz) rolling oscillation which sometimes occurs during rapid rolling maneuvers ("roll ratchet") is shown in Figure 4. Refs. 38, 39 indicate that this can be associated with the pilot's neuromuscular actuation system's resonant peak.

The final entry in Figure 3, "Acceleration-Induced Phenomena," can appear in several guises. For instance, acceleration feedbacks may be associated with the neuromuscular system limb-manipulator "bobweight" effect or with whole-body acceleration and vibration feedthroughs (Ref. 57); these are both essentially independent of human pilot central processes other than deliberate changes of muscular tension. Accelerations can also act through the human's perceptual processes to set up major feedback pathways which are on a par with visual pathways. In this form, accelerations can conceivably serve in parallel

DIVIDED ATTENTION PHENOMENA

Reduced System Bandwidth (crossover frequency)

Increased Error in Closed-Loop Aspects

NEUROMUSCULAR ACTUATION SYSTEM PHENOMENA

High-Frequency "Actuation" Dynamics

Affected by intrinsic coupling with manipulators

Impacts closed-loop high-frequency (beyond crossover characteristics)

Potential Source of Inadvertent Feedbacks of Local Accelerations

Limb manipulator "bobweight"

ACCELERATION-INDUCED PHENOMENA

Acceleration and Vibration Feedthrough

Acceleration as a Feedback Cue

Figure 3. Additional Human Pilot Dynamic Features

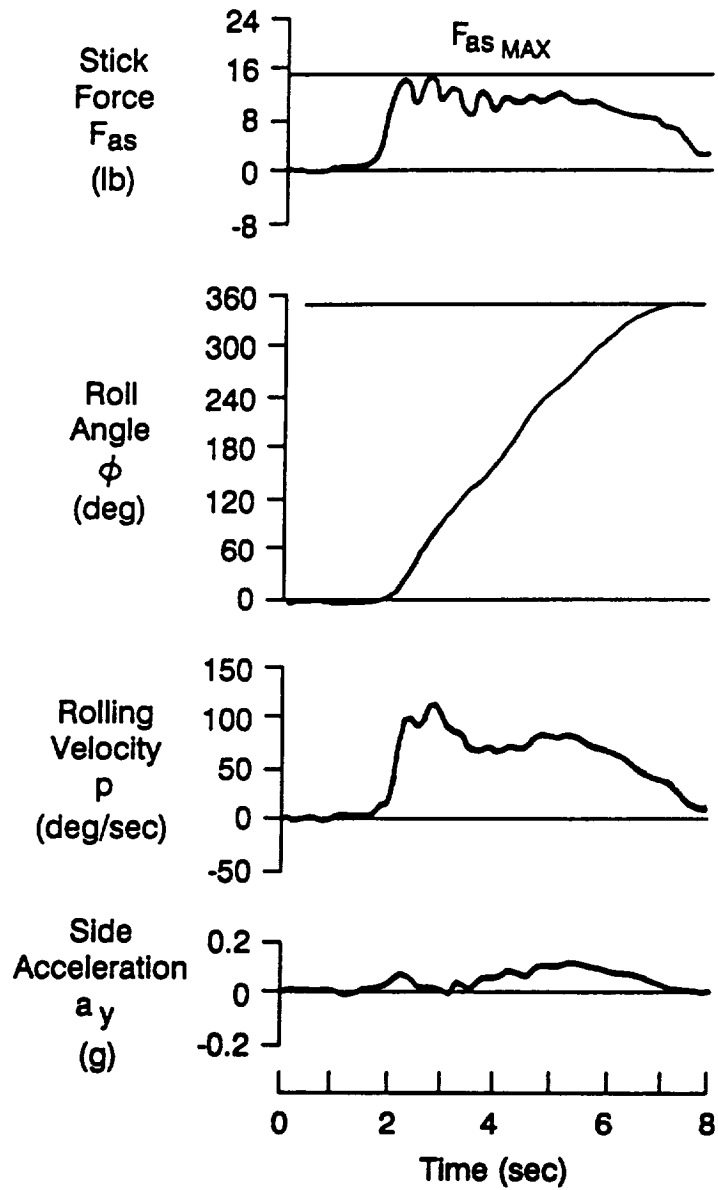

Figure 4. High Frequency PIO – Roll Ratchet (Adapted from Refs. 38, 59)

feedback pathways or as one stage in transition processes in which visual and acceleration cues compete for dominance.

A. HUMAN PILOT DYNAMICS – COMPENSATORY BEHAVIOR

Compensatory behavior will characteristically be present when the commands and disturbances are random-appearing and when the only information acted on by the pilot consists of system errors or aircraft outputs. Under full-attention conditions the pilot exerts continuous closed-loop control on the aircraft so as to minimize system errors in the presence of commands and disturbances.

The time traces of Figure 5 illustrate the nature of compensatory control. The system is a roll-control tracking task in which the rolling velocity becomes proportional to the pilot's aileron output after a first-order lag given by the roll-subsidence time constant, T . Notice that the system output follows the system forcing function command to the closed-loop pilot-vehicle system quite closely. To accomplish this the pilot develops an anticipatory lead $(T_L s + 1)$ which approximately cancels the airplane's roll-subsidence lag $1/(Ts + 1)$. This can be demonstrated using the Figure 5 time traces by comparing the system roll error with the pilot's output lagged by the roll-subsidence lag time constant $(Ts + 1)$. When the latter time history is shifted by a time increment τ_h , the two traces are very much alike. This correspondence suggests not only that the pilot has generated a lead to cancel the vehicle lag, but that the pilot's higher frequency lags can be approximated at the lower frequencies by the time delay, τ_h . The implication is that, when the pilot's characteristics are represented by a describing function, Y_{pe} , and the aircraft roll angle to aileron dynamics by the transfer function, Y_c , the open-loop describing function for the roll control task of Figure 5 would be,

$$\begin{aligned}
 Y_{pe} Y_c &\doteq \underbrace{K_p e^{-\tau_h s} (T_L s + 1)}_{\text{Pilot}} \underbrace{\frac{K_c}{s(Ts + 1)}}_{\text{Aircraft}} \\
 &\doteq \frac{\omega_c e^{-\tau_h s}}{s}, \quad \text{for } |s| \text{ near } \omega_c
 \end{aligned} \tag{1}$$

where $\omega_c = K_p K_c$. As explained further below, this equation has become ubiquitous in manual control, and is commonly referred to as the "crossover" model or law.

Just how well the "crossover model" works can be subjected to a more refined examination using the frequency response of the open-loop pilot-vehicle system. An example is shown in Figure 6. There it is apparent that the crossover law is an excellent approximation to the open-loop pilot-aircraft dynamics in the frequency range around the crossover frequency, ω_c (where the open-loop amplitude ratio equals 1).

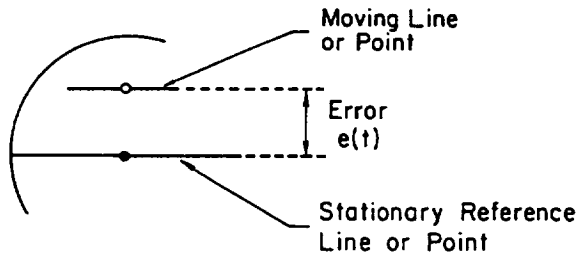

COMPENSATORY DISPLAY

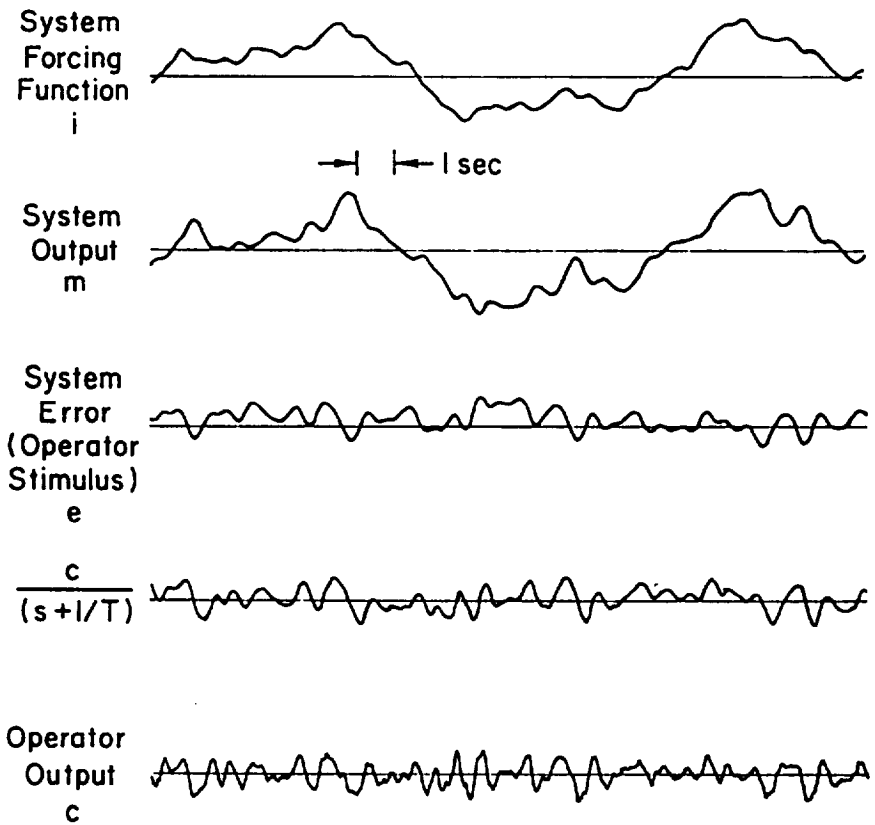
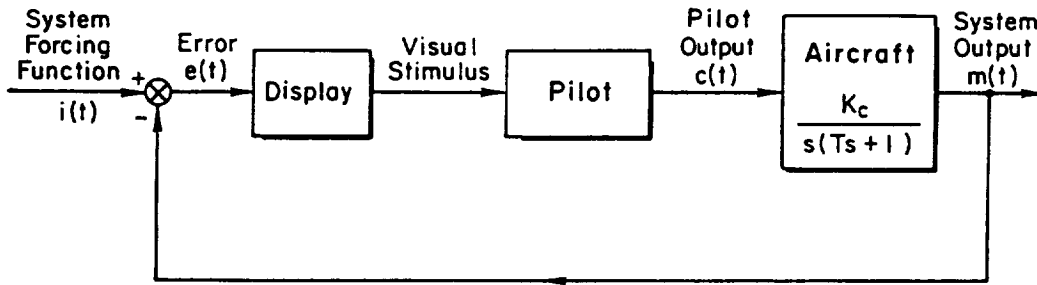
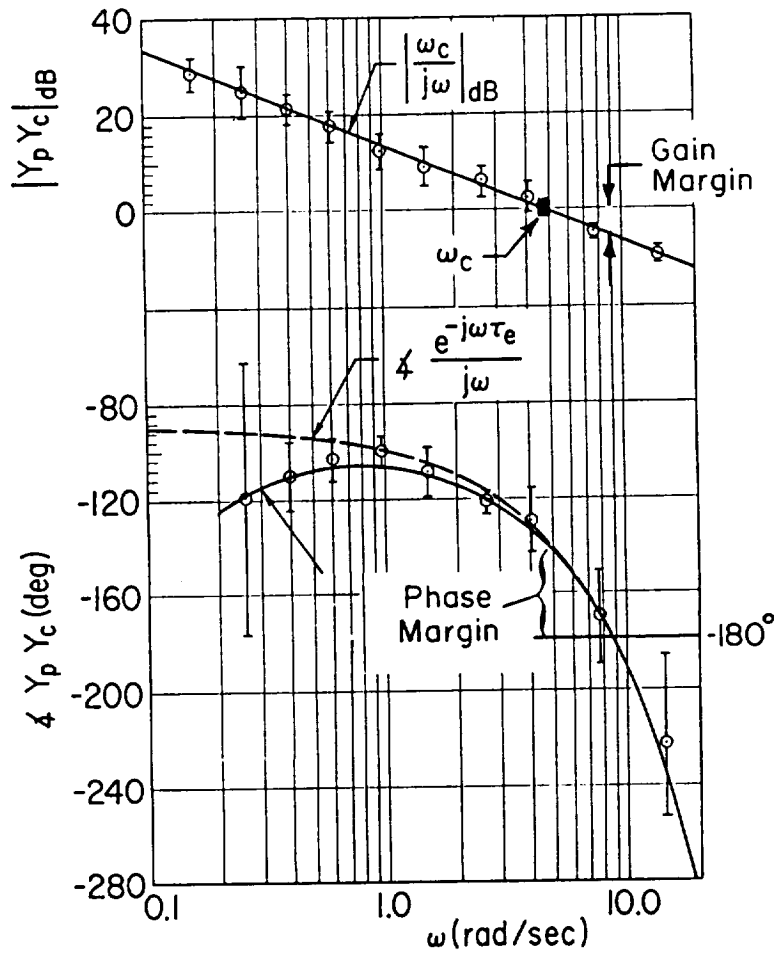

Figure 5. Simple Compensatory System and Time Responses (Adapted from Ref. 48)



$$\begin{array}{c} \text{Pilot} \\ \hline Y_p Y_c \\ \hline \text{Vehicle} \end{array} \cong \frac{\omega_c e^{-j\omega\tau_e}}{j\omega} \quad ; \text{ near } \omega_c$$

Figure 6. Crossover Model for Compensatory Systems (Adapted from Refs. 48, 60)

Over the past three decades a great many experiments conducted with many different controlled element forms have shown that this type of behavior can be generalized into an approximate "behavioral law" for full-attention compensatory operations (see, e.g., Refs. 48, 61). In general, the pilot adopts a situation-specific dynamic transfer characteristic form which makes the open-loop pilot-vehicle system dynamics emulate the "crossover model." (The primary exceptions to this general rule are extremely difficult-to-control marginal cases such as divergences with time constants approaching the pilot's effective time delay.) With this generalization, the crossover model states:

- 1) that the human pilot's transfer characteristics will be different for each set of aircraft dynamics, but that
- 2) the form of the composite total open-loop system dynamics will be substantially invariant, with the effective time delay, τ_e , and crossover frequency, ω_c , being situation-specific.

To make the generalization cover many controlled element characteristics does require an adjustment in the effective time delay. Consider, for instance, a set of high frequency characteristics given by the following group of leads and lags, which may stem from both the aircraft and the pilot's higher frequency dynamics.

$$Y_{\text{high}} = \frac{e^{-\tau_1 s} \prod_{i=1}^n (T_i s + 1) \prod_{i=1}^m \left[\left(\frac{s}{\omega_i} \right)^2 + \frac{2\zeta_i}{\omega_i} s + 1 \right]}{\prod_{j=1}^p (T_j s + 1) \prod_{j=1}^q \left[\left(\frac{s}{\omega_j} \right)^2 + \frac{2\zeta_j}{\omega_j} s + 1 \right]} \quad (2)$$

The phase angle associated with this combination will be,

$$\phi_{\text{high}} = -\tau_1 \omega + \sum_{i=1}^n \tan^{-1} T_i \omega - \sum_{j=1}^p \tan^{-1} T_j \omega + \sum_{i=1}^m \tan^{-1} \frac{2\zeta_i \left(\frac{\omega}{\omega_i} \right)}{1 - \left(\frac{\omega}{\omega_i} \right)^2} - \sum_{j=1}^q \tan^{-1} \frac{2\zeta_j \left(\frac{\omega}{\omega_j} \right)}{1 - \left(\frac{\omega}{\omega_j} \right)^2} \quad (3)$$

When all the $1/T_i$, $1/T_j$, ω_i , and ω_j are large compared to the crossover frequency, this phase angle can be approximated in the crossover region by replacing the arc tangents with their arguments, and recognizing that the $(\omega/\omega_i)^2$ and $(\omega/\omega_j)^2$ terms are small compared to one, i.e.,

$$\begin{aligned} \phi_{\text{high}} &= -\tau_1 \omega - \underbrace{\left[\sum_{j=1}^p T_j + \sum_{j=1}^q \frac{2\zeta_j}{\omega_j} - \sum_{i=1}^n T_i - \sum_{i=1}^m \frac{2\zeta_i}{\omega_i} \right]}_{\tau_2} \omega \\ &= -(\tau_1 + \tau_2) \omega, \\ &= -\tau_e \omega, \end{aligned} \tag{4}$$

Thus, the effective time delay, τ_e , is a low-frequency approximation to the combination of all manner of high-frequency pure delays, lags and leads. Its two major components are: 1) the effective composite time delay of the controlled element (including manipulator effects) — the sum of the aircraft's lags minus leads at frequencies well above crossover; and 2) the high frequency dynamics of the human operator. The composite is approximated by a pure delay which has an equivalent phase shift at frequencies within the crossover region. The amplitude ratio and phase for crossover models with several values of τ_e are illustrated on the Bode plots of Figure 7a. Note that the amplitude ratio is independent of τ_e . In the gain-phase diagram of Figure 7b the frequency parameter is $\tau_e \omega$, and the crossover frequency is arbitrarily set to occur when the phase is -110° . This anticipates a convention which will be used later.

The crossover frequency, ω_c , has the usual feedback system physical interpretation as the metric that divides the world of the pilot-aircraft control system into two frequency regimes, corresponding to open-loop amplitude ratios greater than or less than 1. Over the entire low frequency region (up to approximately ω_c), the benefits of feedback are present, e.g., the closed-loop system output/input will be approximately 1; the output follows the input, the error is reduced, etc. That this is indeed the case is readily apparent from the time traces of Figure 5 in which the output nearly duplicates the input. Above the crossover frequency the system becomes essentially open loop, consisting of the high-frequency pilot dynamics in series with the high-frequency aircraft characteristics. Thus, above ω_c the benefits of feedback are not present.

The degree of system stability is indicated by how closely the open-loop amplitude ratio approaches 1 (zero dB) between the crossover frequency, ω_c and the neutral stability frequency, ω_u , where the open-loop phase angle is -180° . This is measured by the gain and phase "margins", and the "peak magnification ratio." The system would become neutrally stable if: the pilot's gain were increased so as to make the

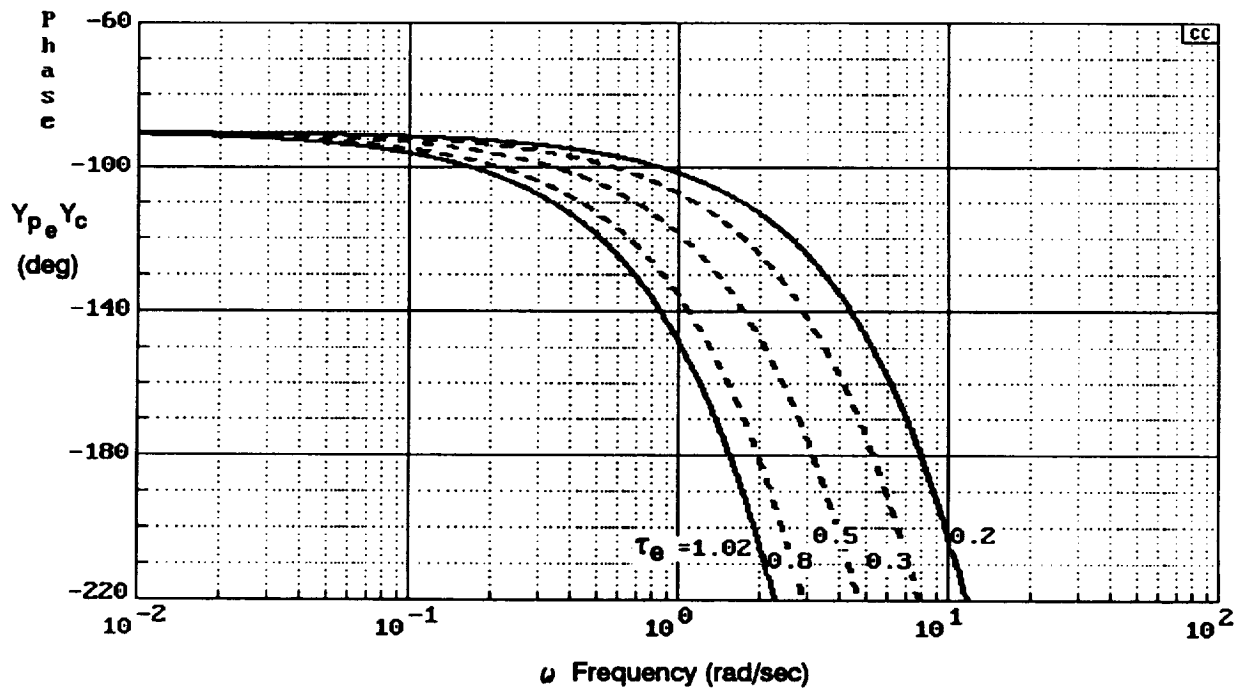
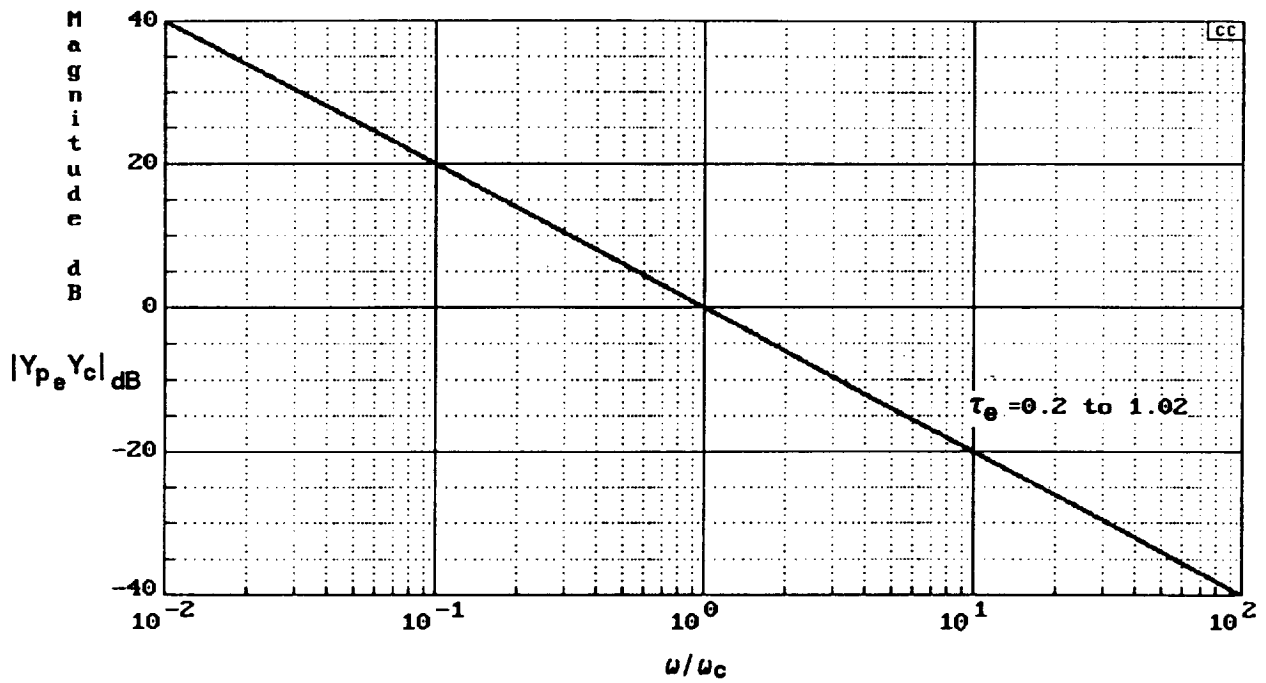

Figure 7a. Bode Diagrams for Crossover Model

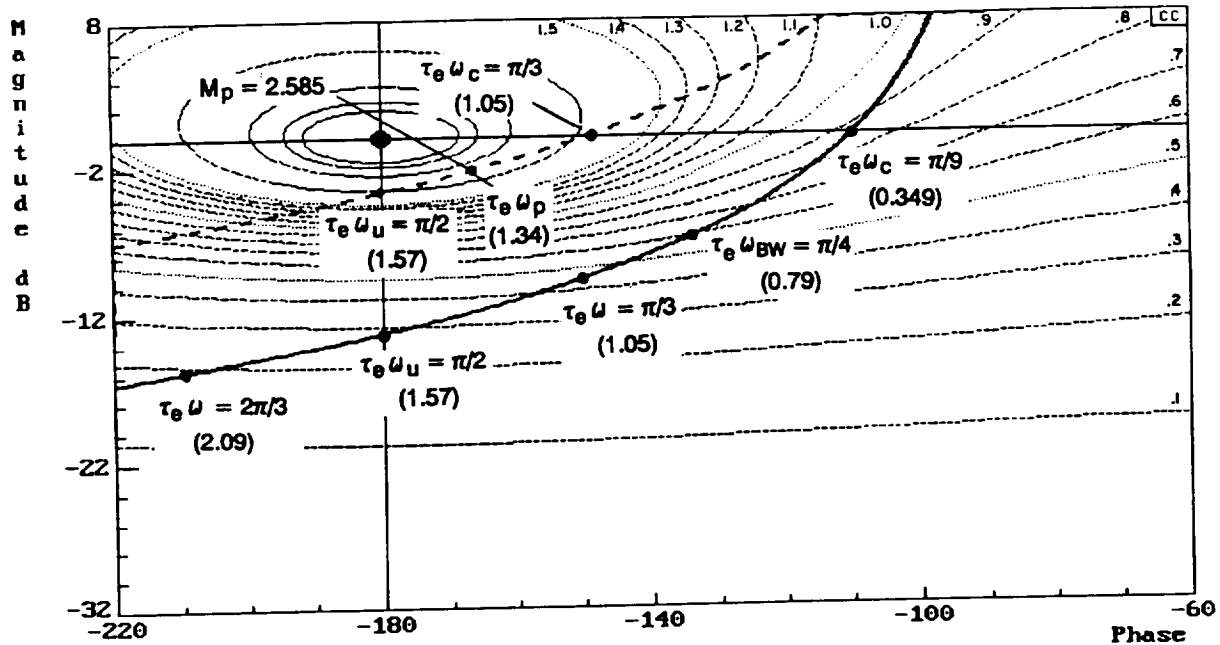

Figure 7b. Gain Phase Diagrams for Crossover Model

crossover frequency equal the frequency at which the open-loop system phase is -180° (gain margin = 0); or the airplane's net high frequency lags were increased to reduce the phase margin to zero. It is in this region of close proximity to the -1 neutral stability point that the portraits of the open-loop system in the form of Bode plots and the gain phase plot emphasize different, but complementary, aspects of the system. The data presented are, of course, identical, and one can translate from one to the other of the representations with ease. Both the gain-phase and conventional Bode diagrams clearly show phase and gain margins, the points at the crossover and neutrally stable frequencies. The gain-phase representation adds a major third point — the "closest approach" to the minus one neutral stability point. This tangency of the gain-phase plot with the "M circles" of the Nichols Chart defines the maximum "peak magnification ratio," M_p , or resonance of the closed-loop system and the resonant frequency, ω_p . For the neutrally stable case the crossover, resonance, and neutral stability frequencies coalesce, and the peak magnification ratio becomes infinite.

A version of the gain-phase plot of the crossover model which is more representative of a normal pilot-vehicle system is given by the dashed line of Figure 7b. Here the phase margin of 30° lies within the 20° to 40° (Ref. 61) range typical of full-attention pilot-vehicle system operations. The neutral stability frequency remains at $\tau_e\omega_u = \pi/2$, but the crossover frequency becomes $\tau_e\omega_c = \pi/3$, and the resonant frequency is $\tau_e\omega_p = 1.34$. The peak magnification ratio is 8.250 dB or 2.585 in linear units.

The phase margin for the crossover model will be,

$$\begin{aligned}\phi_m &= -\pi - \left[-\frac{\pi}{2} - \tau_e \omega_c \right] \\ &= -\frac{\pi}{2} + \tau_e \omega_c\end{aligned}\quad (5)$$

When the phase margin is zero the unstable frequency becomes

$$\omega_u = \frac{\pi}{2\tau_e} \quad (6)$$

PIOs can be manifestations of this last point. For Eq. 6 to be a good estimate of PIO frequency for a compensatory behavior case requires the considerations underlying Eqs. 4 and 6 to extend to the unstable frequency, ω_u . When this is not the case the crossover model can be adjusted slightly by adding the actual dynamics which have breakpoints between ω_c and ω_u , and adjusting the τ_e values accordingly.

A useful indication of pilot-vehicle system sensitivity to gain changes near instability is the slope of the gain-phase curve in that region. As defined in Ref. 7, an "Average Phase Rate" is

$$\text{Average Phase Rate, } \phi'_{\omega_u} = \frac{\phi_{\omega_u} - \phi_{2\omega_u}}{\omega_u} \quad (7)$$

For the crossover model this is simply τ_e rad/(rad/sec). Expressed in other units,

$$\begin{aligned}\phi'_{\omega_u} &= 57.3 \tau_e \text{ }^\circ/(\text{rad/sec}) \\ &= 360 \tau_e \text{ }^\circ/\text{Hz}\end{aligned}\quad (8)$$

The pilot's contribution to effective delay will include a minimum of 0.1 sec for the neuromuscular system and an additional increment which depends on the amount of lead generation required of the human to offset the controlled element deficiencies in order to make good the crossover model form. Estimates of pilot dynamics for a specific set of aircraft dynamics can be made using the detailed data and models given in Refs. 48 and 61. To give some appreciation for quantitative values, Table 2 presents crossover model estimates for rate-command ($Y_c = K_c/s$) and acceleration-command ($Y_c = K_c/s^2$) aircraft, with high-frequency actuation and computation dynamics approximated by a net delay of 0.05 sec.

As illustrated by this example with idealized effective aircraft dynamics, the effective lags not only govern the potential PIO frequency, but also the sensitivity to pilot adjustments near the region of instability. The idealized dynamics cover a fair range of effective vehicle dynamics; they therefore provide an indication of linear-system PIO frequencies which can be explained on the basis of high-gain, compensatory system, pilot behavior.

TABLE 2

CROSSOVER MODEL CHARACTERISTICS FOR IDEALIZED CONTROLLED ELEMENTS

| Idealized Aircraft Y_c | Pilot, τ_h (sec) | Effective τ_e (sec) | ω_u (rad/sec) | ϕ'_{ω_u} | | Crossover Characteristics | |
|-----------------------------------|--------------------------|-----------------------------|-------------------------|--------------------|--------|---------------------------|-------------------|
| | | | | (°/rad/sec) | (°/Hz) | ω_c (rad/sec) | ϕ_m (deg) |
| Rate Command K_c/s | 0.25 | 0.30 | 5.25 | 17.2 | 108 | 4.1 | 20 |
| Acceleration Command K_c/s^2 | 0.40 | 0.45 | 3.50 | 25.8 | 162 | 2.3 | 30 |

Note: τ_h and ω_c/ω_u are based on Ref. 61.

B. HUMAN PILOT DYNAMICS – PURSUIT BEHAVIOR

When the command inputs can be distinguished from the system outputs by virtue of the display (e.g., the system input and output are shown or detectable as separate entities relative to a reference) or preview (e.g., as in following a curved roadway that can be seen far ahead) a *pursuit* block can be added as shown in Figure 8. The introduction of this new signal pathway permits an open-loop control in conjunction with the compensatory closed-loop error correcting action. With the pursuit system organization the error can be reduced by the human's operations in two ways: by making the open-loop describing function large compared with 1; and by generating a pursuit path describing function which tends to be the inverse of the controlled element (Ref. 48). This can, of course, only be done over a limited range of frequencies. The quality of the overall control in the pursuit case can, in principle, be much superior to that where only compensatory operations are possible. A typical comparison between a pursuit plus preview system and its compensatory variant is given in Figure 9, where the improvement in effective system crossover frequency is greater than a factor of three (Ref. 51).

In many flight phases the pilot has sufficient cues to permit a pursuit system organization. Approach and landing with good runway visual cues and formation flying in clear weather are typical examples. Displays which provide good preview can also serve to support the superior performance available with pursuit organizational structures.

As contrasted with performance, the stability of pursuit systems is basically the same as that of its compensatory closed-loop component. Thus, the considerations given above for compensatory behavior apply as well to the pursuit case.

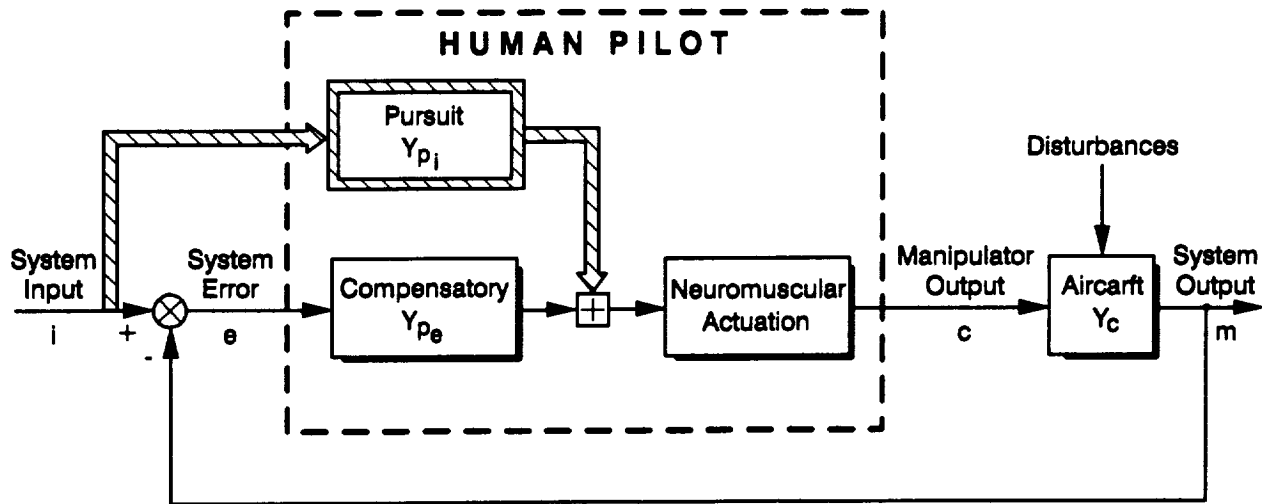

| TRANSFER CHARACTERISTICS | COMPENSATORY | PURSUIT |
|---|---------------------------------------|---|
| <u>Open-Loop</u> Output/Error, $m/e = Y_{\beta}$ | $Y_{p_e} Y_c$ | $\frac{(Y_{p_i} + Y_{p_e}) Y_c}{1 - Y_{p_i} Y_c}$ |
| <u>Closed-Loop</u> Output/Input, m/i | $\frac{Y_{p_e} Y_c}{1 + Y_{p_e} Y_c}$ | $\frac{(Y_{p_i} + Y_{p_e}) Y_c}{1 + Y_{p_e} Y_c}$ |
| Error/Input, e/i | $\frac{1}{1 + Y_{p_e} Y_c}$ | $\frac{1 - Y_{p_i} Y_c}{1 + Y_{p_e} Y_c}$ |

Figure 8. Closed-Loop Pilot-Vehicle System Possibilities
(Compensatory and Pursuit)

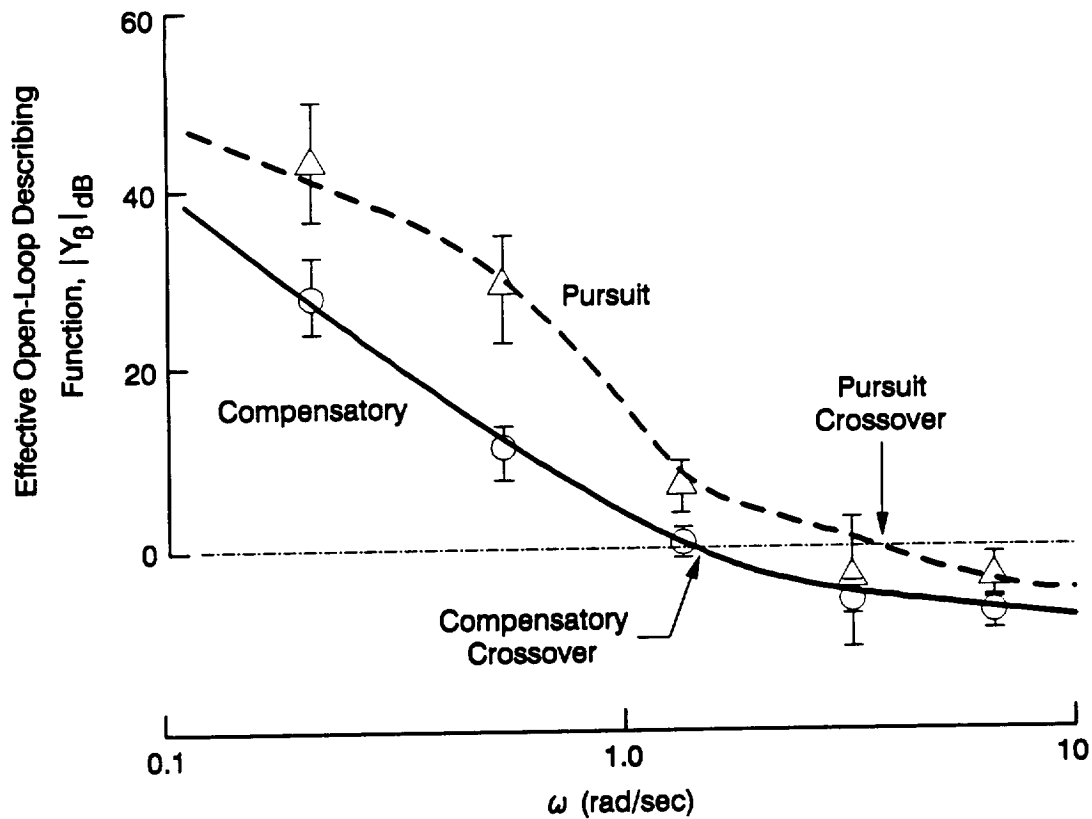

Figure 9. Comparative Data for Pursuit and Compensatory Conditions
(Adapted from Ref. 51)

When essential cues are lost (e.g., as with reduced effective preview), or are unattended (e.g., when appropriate division of attention and/or situational awareness breaks down), the pilot-vehicle system can change from a pursuit to a compensatory organization. Depending on the precise details, such transitions can introduce PIO triggering inputs as well as greatly reduced closed-loop system performance.

C. HUMAN PILOT DYNAMICS – PRECOGNITIVE BEHAVIOR

An even higher level of control is possible. When complete familiarity with the controlled element dynamics and the entire perceptual field is achieved, the highly-skilled human pilot can, under certain conditions, generate neuromuscular commands which are deft, discrete, properly timed, scaled and sequenced so as to result in machine outputs which are almost exactly as desired. These neuromuscular commands amount to conditioned responses which may be triggered by the situation and the command and control quantities, but they are not continuously dependent on these quantities (Refs. 44, 45, 48, 50, 62). This pure open-loop programmed-control-like behavior is called *precognitive*. Most highly-skilled movements which have been so thoroughly locked-in as to be automatic ("without thought") fall under this category. Like the pursuit pathway, it often appears in company with compensatory follow-up

or simultaneous operations. This forms a dual-mode form of control in which the human's manual output is initially dominated by the precognitive action, which does most of the job, and is then completed when needed by compensatory error-reduction actions.

A special case of precognitive behavior is *Synchronous (Precognitive) Behavior*. When sinusoidal inputs appear in pilot-vehicle systems the pilot progresses through several phases adapting to the input. Initially the periodic character is not recognized, and the pilot treats the input as unpredictable and operates off errors only (compensatory behavior). After intermediate adaptation phases (which can include pursuit behavior), the pilot ultimately recognizes that the input is a sinusoid and, up to frequencies of about 3 Hz, can duplicate the sinusoid with no phase lag (Ref. 48). If a transfer characteristic is assigned to this mode the pilot dynamics, $Y_p \doteq K_p$. This would represent the pilot's ability to "follow" the sinusoid with no phase lag, although this is not a totally legitimate "transfer" characteristic. Instead, the pilot is generating the output sinusoid internally; indeed, the pilot's response can continue even if visual inputs are cut off, although there is a drift in frequency as time goes on. In the presence of sustained oscillation, however, the pilot's output does become phase-locked, so the pure gain model is appropriate. Synchronous operations can also occur in which the pilot's outputs are much closer to trapezoidal or even rectangular periodic waves than to sinusoids. In all these cases the effective pilot describing function will still be a gain.

As will become apparent in connection with the case studies of PIO which appear in the next section, "synchronous" behavior is, perhaps, the most important type of pilot action for large amplitude severe PIOs. In these instances, the oscillatory condition of Eq. 1 becomes,

$$\Delta Y_c = -180^\circ \quad (9)$$

Here the unstable frequency can be considerably higher than that for compensatory control because the pilot's contribution to the effective time delay is not present. Some appreciation for this can be gained by considering effective vehicle dynamics of the rate control class (ideally, $Y_c = K_c/s$). When a composite time delay, τ_c , is added to account for high-frequency effective aircraft lags, the controlled element has the same form as examined previously with the crossover model. The difference is that here the pilot's dynamics are approximated by a pure gain, while the rest of the open-loop dynamics are idealized attitude/pilot-output transfer characteristics. Table 3 considers this basic form for a series of vehicle effective time delays. This table includes the "aircraft attitude bandwidth," $\omega_{BW\theta}$, which for these cases is the frequency at which the effective aircraft phase angle is -135° , and the "phase delay," τ_p , which is defined as

$$\tau_p = \frac{\Delta Y_c(2\omega_{180}) + \pi}{2\omega_{180}} \quad (10)$$

where ΔY_c is in radians. For the example cases at hand τ_p will be just $\tau_e/2$. It is also connected directly with the "Average Phase Rate" (Eq. 7) by

$$\begin{aligned} \tau_p &= \frac{\phi'_{\omega_u}}{114.6}, \quad \text{when } \phi'_{\omega_u} \text{ is } ^\circ/\text{rad}/\text{sec} \\ &= \frac{\phi'_{\omega_u}}{720}, \quad \text{when } \phi'_{\omega_u} \text{ is } ^\circ/\text{Hz} \end{aligned} \quad (11)$$

TABLE 3
CLOSED-LOOP CHARACTERISTICS FOR SYNCHRONOUS PILOT AND
IDEALIZED RATE-COMMAND CONTROLLED ELEMENTS

$$Y_c = \frac{K_c}{s} e^{-\tau_e s}$$

| Effective Time Delay τ_e (sec) | $\omega_{BW\theta}$ (rad/sec) | τ_p (sec) | ω_u (rad/sec) | ϕ'_{ω_u} | |
|---|----------------------------------|-------------------|-------------------------|----------------------|-----------------|
| | | | | ($^\circ$ /rad/sec) | ($^\circ$ /Hz) |
| 0.10 | 7.85 | 0.05 | 15.7 | 5.73 | 36 |
| 0.15 | 5.24 | 0.075 | 10.5 | 8.60 | 54 |
| 0.20 | 3.93 | 0.10 | 7.85 | 11.46 | 72 |
| 0.25 | 3.14 | 0.125 | 6.28 | 14.32 | 90 |
| ↑ | | | | | |
| ↓ PIO Potential | | | | | |
| 0.30 | 2.62 | 0.15 | 5.23 | 17.19 | 108 |
| 0.35 | 2.24 | 0.175 | 4.49 | 20.06 | 126 |
| 0.40 | 1.96 | 0.20 | 3.92 | 22.92 | 144 |

Although the emphasis here is on the basics of pilot-vehicle interaction phenomena associated with PIOs, there are both direct and implicit connections with flying qualities. The presence of severe PIOs is the antithesis of good flying qualities, and some factors associated with poor flying qualities can offer relevant clues in the quest for PIO understanding. Table 3 offers the first of several opportunities to bring to bear some of these conventional flying qualities items, specifically the "airplane bandwidth," "phase delay," and "average phase rate" measures. These quantities, which are important measures for various flying qualities purposes, have recently been used to develop some guidelines for PIO potential. Thus, in Refs. 1 and 7 an average phase rate of less than 100 $^\circ$ /Hz is considered as a boundary associated with PIO potential, while Ref. 8 suggests that an aircraft "will be susceptible to PIOs if phase delay $\tau_p \geq 0.14$ sec up- and -away, 0.15 sec in landing." The 100 $^\circ$ /Hz corresponds to a τ_p of 0.14 sec, so the statements

are compatible. In terms of the Table 3 cases these criteria would suggest that idealized rate-command effective vehicle characteristics with an effective time delay greater than 0.25 sec for up-and-away flight or 0.30 sec for landing are likely to be PIO prone on a synchronous control basis.

Another type of pilot controller action which exhibits responses akin to "synchronous" behavior is "vibration feedthrough." This is a direct feedthrough by the pilot into the manipulator of lightly damped oscillatory motions. Typically the source is vibratory or flexible mode acceleration. As determined in Refs. 57 and 63 the amount of the feedthrough can be substantial up to frequencies as high as 10 Hz. This action can appear as a pure gain or slightly time-delayed pure gain to acceleration inputs.

D. PILOT ABERRANT BEHAVIOR CHARACTERISTICS

The above description of pilot behavioral patterns and characteristics suggests that many possible abnormal forms of pilot dynamic behavior can contribute to PIO. A summary is given in Figure 10. The first three sources are common in early flight operations with a new aircraft. To the extent that they are associated with pilot inexperience with a particular aircraft situation they ordinarily disappear as the pilot adopts a more appropriate system organization and/or transfer characteristics. As some of the examples described next will make clear, they remain PIO possibilities for unusual situations in an otherwise very familiar aircraft.

The high-frequency "ratchet" has already been exemplified in Figure 4. The pilot's neuromuscular system resonance at 2-3 Hz may very well couple with higher frequency airplane modes due to flexible structures, mechanical control system dynamics, etc. Desirable stick and rudder inceptor (manipulator) characteristics and associated pilot-command input filtering which minimize such possibilities are underappreciated areas for fruitful research.

Transitions in pilot behavioral organization are probably major sources of pilot-induced upsets which can serve as PIO triggers. As examination of Figure 9 reveals, a switch from pursuit to compensatory operation can significantly reduce the available closed-loop system bandwidth, with a concomitant expansion of system error, etc. As an illustrative example, consider driving across a narrow bridge when suddenly presented with an on-coming truck. If the driver abandons a stare mode with a far-ahead fixation point (which permits the separate perception of roadway/bridge and car position and heading relative to the surround needed for pursuit operation) and changes to a closer-in perception of truck/car clearance, the driver will be shifting to compensatory behavior, with a correspondingly increase in potential error. Much the same kind of system bandwidth and dynamic performance reduction occurs in carrier approach if the pilot starts to track or "spot" the deck.

INAPPROPRIATE BEHAVIORAL ORGANIZATION

INAPPROPRIATE PILOT ADAPTATION WITHIN AN ESTABLISHED BEHAVIORAL ORGANIZATION

EXCESSIVE PILOT GAIN

Conventional Compensatory System Crossover PIO (2-5 rad/sec)

Synchronous Pilot PIO (0.5-3Hz)

High Frequency "Ratchet" (2-3 Hz)

TRANSITIONS IN PILOT BEHAVIORAL ORGANIZATION

Switching of Key Control Variable

Acceleration-induced (e.g. pitch attitude to normal acceleration)

Task-modng-change induced

Pursuit to Compensatory

Precognitive to Compensatory

POST TRANSITION RETENTION

Figure 10. Sources of Pilot-Induced Oscillations
(Pilot Aberrant-Behavior Characteristics)

The most common pilot behavior shifts involved with PIOs appear to be transitions from full-attention pursuit or compensatory operations in high-gain, high urgency tasks to a synchronous mode of behavior. This leads to significant simplifications for the analytic treatment of fully-developed synchronous PIOs because the pilot's dynamics approximate a pure gain and only the effective controlled element dynamic characteristics enter into the closed-loop situation. The transient nature of the transition itself is, unfortunately, not well understood. Major upsets or triggers, originating from either the pilot (e.g., in dropping a pursuit feedforward, changing attentional focus, etc.) or other system changes are almost invariably involved.

A very important pilot-centered characteristic is "post-transition retention." If, for example, the controlled element dynamics change while the pilot is in a full-attention compensatory task, the pilot's characteristics will ultimately be modified as prescribed by the crossover model. But, the modification

process has several sequential steps. Initially, with the pre-transition dynamics, Y_{c1} , the pilot's characteristics will be Y_{p1} , and the composite will approximate the crossover model. When the controlled-element transition occurs, the pilot retains the same characteristics adapted to the pre-transition effective vehicle dynamics. Then, at least momentarily, the system describing function is $Y_{p1}Y_{c2}$. If these are inappropriate to the "new" vehicle dynamics, the closed-loop system stability can suffer. The retention phase can last from as short a time as one or two reaction times to many seconds. The vehicle dynamics transition may be a consequence of an internal shift, such as a change in the vehicle configuration (e.g., power or flap), stability augments system, etc. It can also stem from nonlinearities sensitive to pilot input amplitudes, such as rate and position limiting.

To understand PIO's which are initiated by a post-transition retention of pre-transition pilot dynamics requires an appreciation of the pre-transition pilot characteristics, Y_{p1} . In pre-transition situations where the pilot is exerting full-attention, high-gain closed-loop control, the pilot dynamics can be estimated using the procedures of Ref. 61. As a simple example, presume that the pre-transition effective aircraft dynamics in the region of pilot-vehicle crossover approximate K_{c1}/s (a rate control) closely enough to require no compensating pilot lead in order to satisfy the crossover model. This will typically be the case for normal operations with a modern stability augmentation system. Then the pilot's amplitude ratio will be a pure gain, and the pre-transition pilot transfer characteristic will be $K_{p1} e^{-\tau_1 s}$. The value of the pilot's effective time delay can be estimated from Table 3 of Ref. 61. For this example, this will be about 0.25 sec. When this form of the pilot's dynamics is combined with the effective aircraft, the calculation of the neutral stability frequency for the pre-transition case is straightforward. Then, to determine the pilot gain, K_{p1} , the crossover frequency must be estimated. For the case with no pilot lead, Ref. 61 indicates that the ratio of the crossover to the neutral stability frequency, ω_c/ω_u , will be 0.78, from which the crossover frequency emerges directly, providing the basis for determination of K_{p1} . The stability of the post-transition retention phase can then be examined by combining the pre-transition pilot dynamics [in this example, $K_{p1} e^{-\tau_1 s}$ with the post-transition effective aircraft dynamics, Y_{c2} .

A pilot behavioral transition which has been proposed as a source of PIO is an attentional switching from attitude to normal acceleration as the primary control variable (Ref. 16). The hypothesis is that, in the presence of a nearly resonant pilot-vehicle closed-loop attitude system, plus a trigger of some sort, the pilot switches his primary control to normal acceleration. This theory has the undoubted merit that it demands the presence of good acceleration cues if a PIO is to appear. This could help "explain" the generally poor ability to predict PIO from fixed-base simulations. Analyses using the hypothesis have also been fruitful in showing PIO susceptibility.

SECTION IV

AIRCRAFT DYNAMIC FEATURES THAT CAN CONTRIBUTE TO PIO

The airplane characteristics which constitute the controlled element with which the pilot interacts consist, in general, of aircraft plus stability augmentation system (SAS), plus stick/pedals (inceptors) and artificial feel system. This composite of dynamic elements is sometimes referred to as the "effective airplane dynamics;" here they are included in the word "aircraft."

The aircraft is the other partner in PIO. Figure 11 summarizes the types of aircraft-centered deficiencies which have or might contribute to PIOs.

"Unfavorable Conventional Aircraft Dynamics," such as lightly damped short-period modes (Refs. 64, 65, 66), or unfavorable roll attitude control/dutch roll mode quadratic dipoles (Refs. 24, 67, 68, 69, 70, 71) were major problems in the past. With modern flight control systems these should not reappear on high-performance aircraft except as artifacts of peculiar SAS failures or engineering naivete. The category should not be abandoned, however, because novel aircraft dynamics from unusual configurations operating close to performance envelope limits will probably always be with us.

Specific examples treated under the other three entries are given below:

A. EXCESSIVE LAGS IN EFFECTIVE VEHICLE (Aircraft Plus Stability Augmentation)

The profound influence of excessive lags on pilot-vehicle system performance and stability has been introduced in the discussions of pilot behavioral modes. For modern aircraft equipped with stability augmentation which corrects unfavorable aircraft dynamics, the low-frequency effect of higher-frequency lags from assorted sources is by far the most important causal factor in those PIOs which can be "explained" by quasilinear theory. The assorted sources of excessive lag include actuators, filters, digital system time delays, mechanical control and feel system, structural, etc. characteristics. "Low frequency" here refers to the frequency region from pilot-vehicle system crossover, ω_c , to an instability frequency, ω_u , whereas "higher-frequency" means those above ω_u .

The following treatment begins with more details on pilot-behavioral modes pertinent to linear PIO analyses. Then the linear PIO tendencies of idealized and some extreme particular configurations are addressed from the perspective of a central governing principle for closed-loop flying qualities. Several flight-based examples are examined in the course of these developments, concluding with two famous PIO examples. These are the Space Shuttle Orbiter ALT-5 PIO, which emphasized the overwhelming importance of excessive time delay as a PIO factor, and the Dryden Digital Fly-by-Wire F-8 experiments which provided definitive results on allowable effective time delay.

UNFAVORABLE CONVENTIONAL AIRCRAFT DYNAMICS

Lightly- Damped Modes in Crossover Region

Unfavorable Quadratic Dipoles

UNDESIRABLE EFFECTIVE VEHICLE (AIRCRAFT + SAS)

Excessive Lags

Low frequency effect of actuator, filter, mechanical controls and feel system, structural, etc. characteristics

Mismatched Pilot-Aircraft Interface Characteristics

Inappropriate controlled-element gain

Inceptor properties

CONTROLLER RATE AND/OR POSITION LIMITING

VEHICLE DYNAMICS TRANSITIONS

Stick Fixed/Stick Free

Vehicle Dynamics Form Changes

Moding Transients

Triggering Disturbances

Figure 11. Sources of Pilot-Induced Oscillations
(Aircraft Dynamic Characteristics)

1. Pilot Dynamic Characteristics in Severe PIOs

As already described, experiments on pilot dynamics with systems in which oscillatory forcing function signals of either the visual or applied acceleration variety indicate that the pilot will lock-in to the basic oscillatory frequency. When this happens the pilot's dynamics at the PIO frequency are approximated by a pure gain, and the pilot is said to be "synchronous." Analyses have assumed, and data interpretations of some famous PIOs (e.g., Refs. 10, 15, 31) have suggested, that synchronous behavior is often present in a fully-developed severe PIO. Although analytical results using the synchronous assumption have been consistent with experiment, actual time response data which definitively demonstrate that synchronous behavior is actually present are lacking.

The best experimental flight test data base to examine the synchronous and compensatory pilot models in the context of severe fully-developed PIOs is provided by Ref. 72. These experiments used the USAF/Calspan variable stability NT-33 aircraft, with three test pilot subjects, in landing approach tasks. Each pilot flew three approaches to a desired touchdown point: one straight in; the other two with left and right side lateral offsets followed by a correction to centerline. Longitudinal flying qualities and PIO tendencies were evaluated using four pairs of short period natural frequency and damping ratios (all selected to be MIL-F-8785C Level 1 for landing approach, Category C conditions), combined with fourteen different flight control system configurations. The phugoid and lateral-directional characteristics, which met Level 1 requirements, were held constant. PIO (Ref. 73) and Cooper-Harper Handling Qualities (Ref. 74) ratings, using the scales of Figures 12a and 12b, pilot comments, and strip chart recordings were obtained.

A large number of PIOs of various levels of severity were obtained in the test series. Those of particular interest here were a number of repeatable fully-developed severe PIOs. These were the worst of the series, all with PIO ratings (PIORs) of 4 or 5, with a high degree of pilot confidence and consistency about the ratings. There were six configurations in this subset. The three -1 entries of Table 4 are the baseline configurations; the remaining entries are the effective vehicle dynamics for the "Severe PIO Subset," which comprise the baseline dynamics plus the additional lags listed. The characteristics of all are depicted in the Bode and Gain/Phase diagrams of Figures 13a-i.

In passing it should be noted that the effective vehicle dynamics for several of the Severe PIO Subset are not always simply the "good" baseline airplane plus excessive higher-frequency lags. For 3-12 and 3-13, the added second-order lags have undamped natural frequencies which are less than the nominal short period undamped natural frequency. In these cases the added lags then create a new, lower-frequency, short period, and the nominal short period takes the role of the added lag. For 2-5 the added first-order lag also occurs before ω_{sp} , and is fairly close to the numerator lead at $1/T_{\theta_2}$. This is a long

| DESCRIPTION | NUMERICAL RATING |
|--|------------------|
| No tendency for pilot induce undersirable motions | 1 |
| Undersirable motions tend to occur when pilot initiates abrupt maneuvers or attempts tight control. These motions can be prevented or eliminated by pilot technique | 2 |
| Undersirable motions easily induced when pilot initiates abrupt maneuvers or attempts tight control. These motions can be prevented or elimated but only at sacriface to task performance or through considerable pilot attention and effort | 3 |
| Oscillations tend to develop when pilot initiates abrupt maneuvers or attempts tight control. Pilot must reduce gain or abandon task or recover | 4 |
| Divergent oscillations tend to develop when pilot initiates abrupt maneuvers or attempts tight control. Pilot must open loop by releasing or freezing the stick | 5 |
| Disturbance or normal pilot control may cause divergent oscillation. Pilot must open control loop by releasing or freezing the stick | 6 |

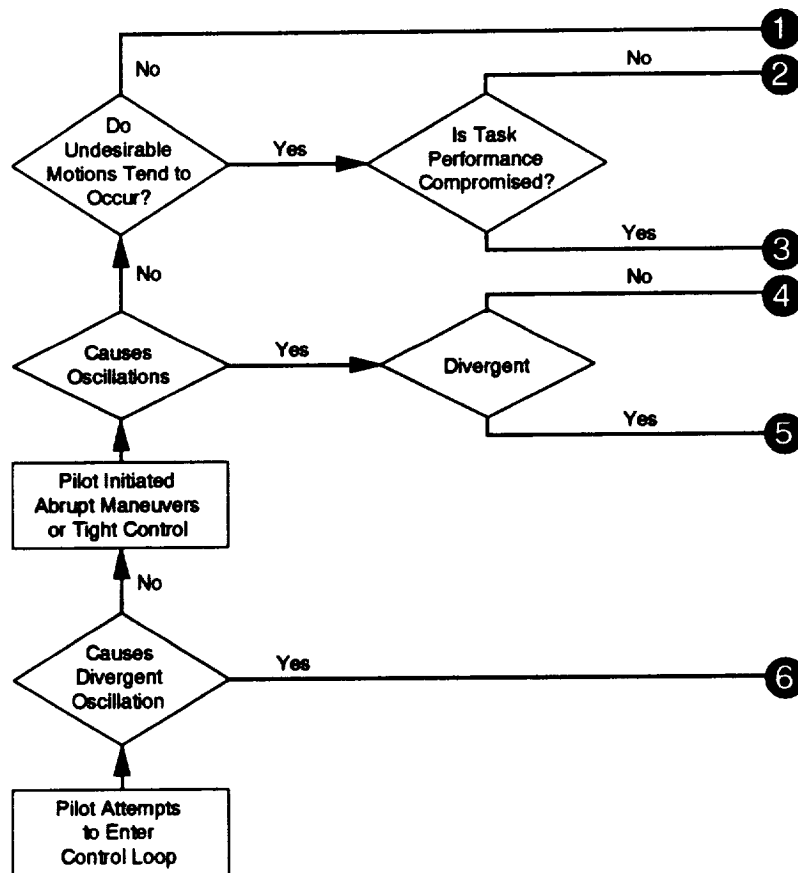

Figure 12a. PIO Rating Scale and Flowchart

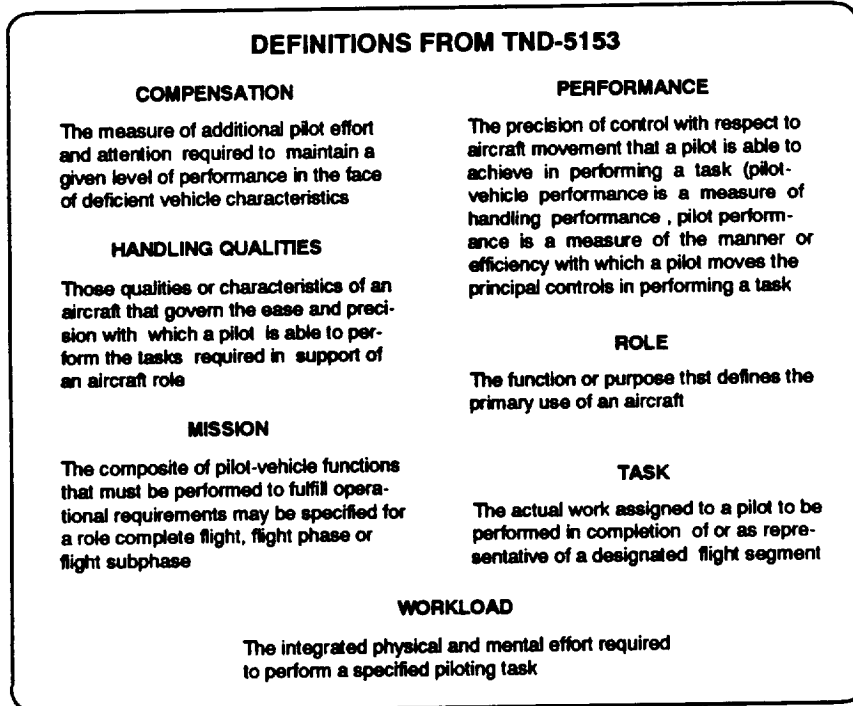
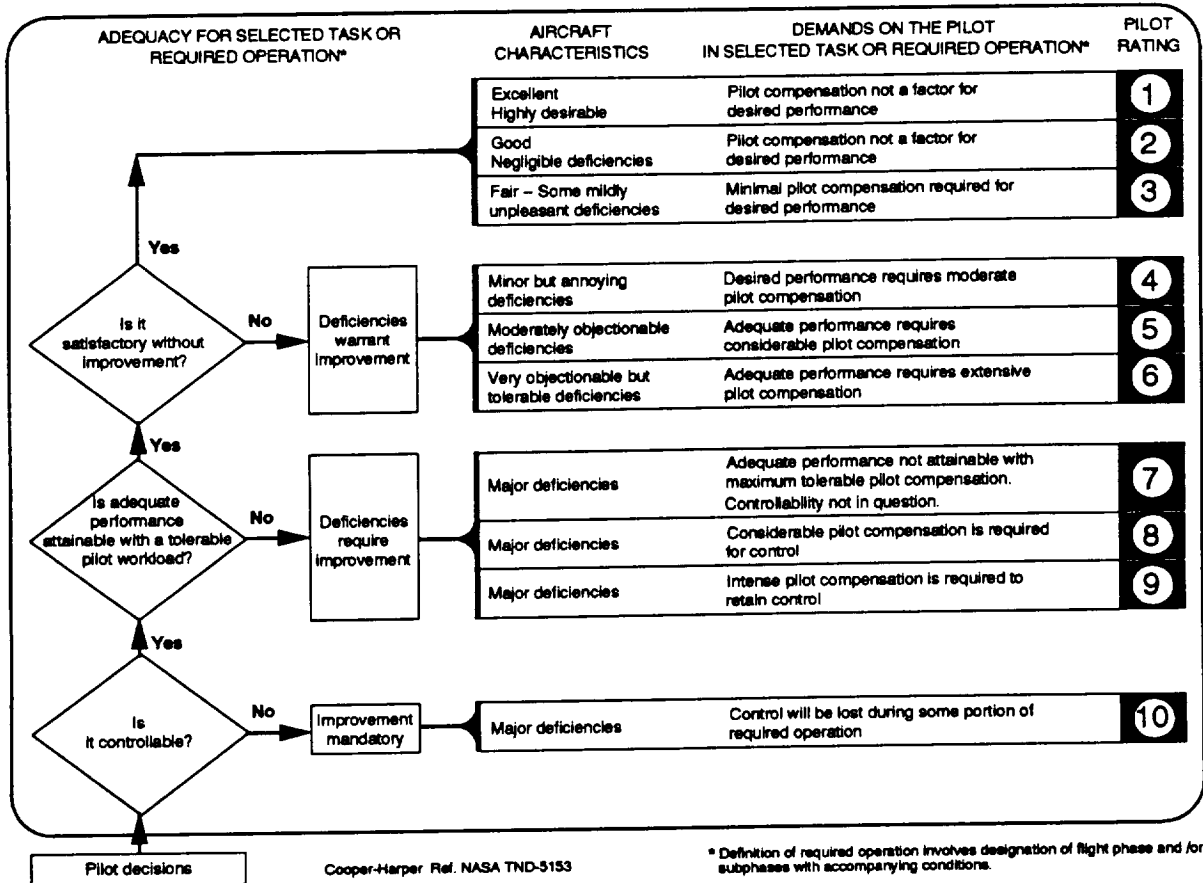
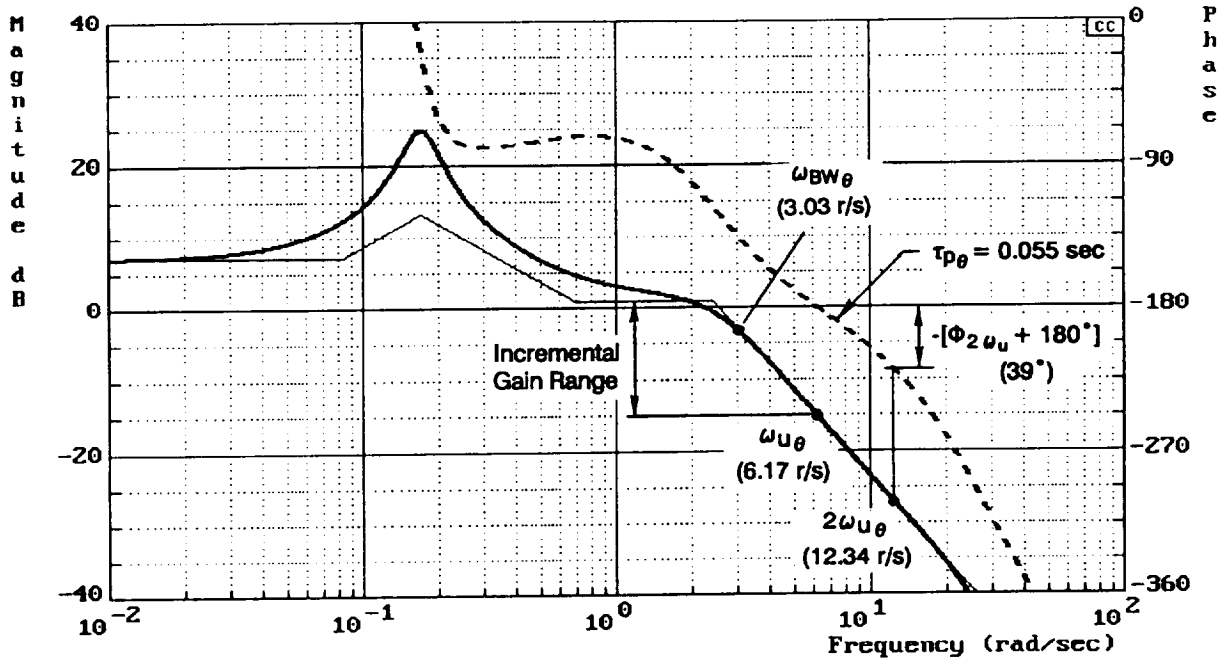

Figure 12b. Cooper-Harper Pilot Rating Scale

TABLE 4
BJORKMAN CONFIGURATIONS WITH SEVERE PIO'S
 Ref. 72

| Configuration | Transfer Function | Ratings | | Attitude Bandwidth ω_{BW} | Phase Delay τ_p | Average Phase Rate | |
|---------------|---|---------|-------|-------------------------------------|-------------------------|--------------------|--------|
| | | CH | PIOR | | | deg/rad/sec | deg/Hz |
| | | | | | | | |
| 2-1 | $\frac{2.46E7 (.0845)(.699)}{[.15,.17][.63,2.41][.6,26][.7,75]}$ | 2/2/3 | 1/1/1 | 3.03 | 0.055 | 6.27 | 39.38 |
| 2-5 | $\frac{1.98E7 (.0845)(.699)}{[.15,.17][.63,2.41][.6,26][.7,75]}$ 1 (1) | 10/7/10 | 4/4/5 | 1.38 | 0.235 | 26.91 | 169.08 |
| 2-8 | $\frac{1.72E9 (.0845)(.699)}{[.15,.17][.63,2.41][.6,26][.7,75]}$ 1 [.7,9] | 8/10/8 | 4/4/4 | 2.14 | 0.192 | 22.02 | 138.36 |
| 3-1 | $\frac{1.17E8 (.0847)(.6987)}{[.17,.16][.97,4.22][.6,26][.7,75]}$ | 5/3/4 | 3/2/2 | 5.60 | 0.059 | 6.80 | 42.74 |
| 3-12 | $\frac{2.35E8 (.0847)(.6987)}{[.17,.16][.97,4.22][.6,26][.7,75]}$ 1 [.7,2] | 7/9 | 4/5 | 1.16 | 0.317 | 36.37 | 228.49 |
| 3-13 | $\frac{6.07E8 (.0847)(.6987)}{[.17,.16][.97,4.22][.6,26][.7,75]}$ 1 [.7,3] | 10/10 | 4/5 | 1.25 | 0.279 | 31.98 | 200.97 |
| 5-1 | $\frac{1.18E7 (.0845)(.6989)}{[.16,.15][.68,1.7][.6,26][.7,75]}$ | 2/5 | 1/1 | 2.11 | 0.053 | 6.05 | 38.00 |
| 5-9 | $\frac{3.45E8 (.0845)(.6989)}{[.16,.15][.68,1.7][.6,26][.7,75]}$ 1 [.7,6] | 7/7 | 4/4 | 1.51 | 0.260 | 29.77 | 187.02 |
| 5-10 | $\frac{1.43E8 (.0845)(.6989)}{[.16,.15][.68,1.7][.6,26][.7,75]}$ 1 [.7,4] | 10/10 | 5/5 | 1.07 | 0.359 | 41.11 | 258.28 |



$$\frac{2.46E7(.0845)(.699)}{[.15, .17][.63, 2.41][.6, 26][.7, 75]}$$

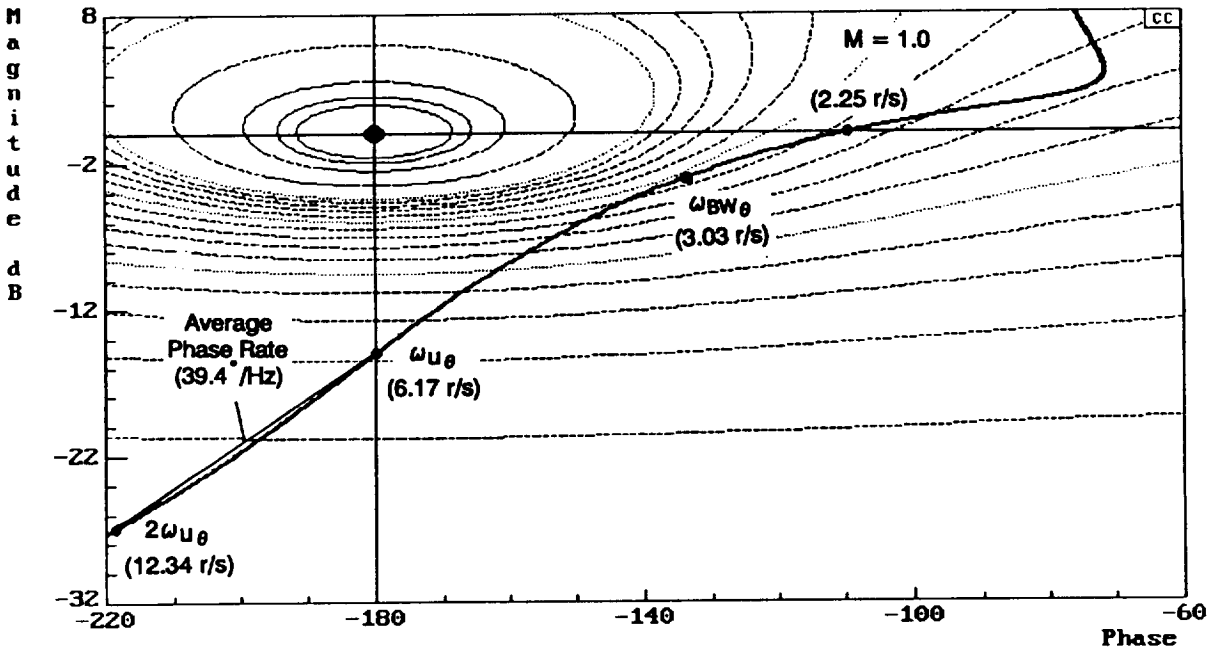
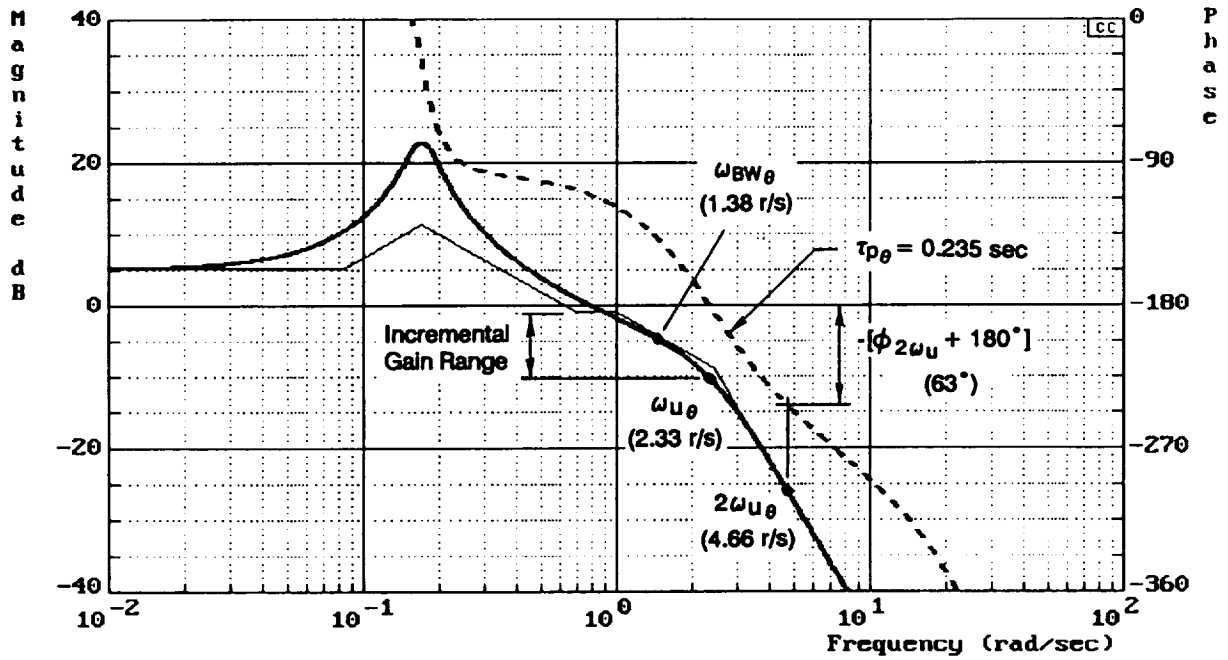

Figure 13a. Baseline Configuration: 2-1 Pilot Ratings: 2/2/3 ; PIOR: 1/1/1 ; $\tau_p = 0.054 \text{ sec}$
Incremental Gain Range = 15.96 dB (6.28)



$$\frac{1.98E7(.0845)(.699)}{[.15, .17][.63, 2.41][.6, 26][.7, 75]} \frac{1}{(1)}$$

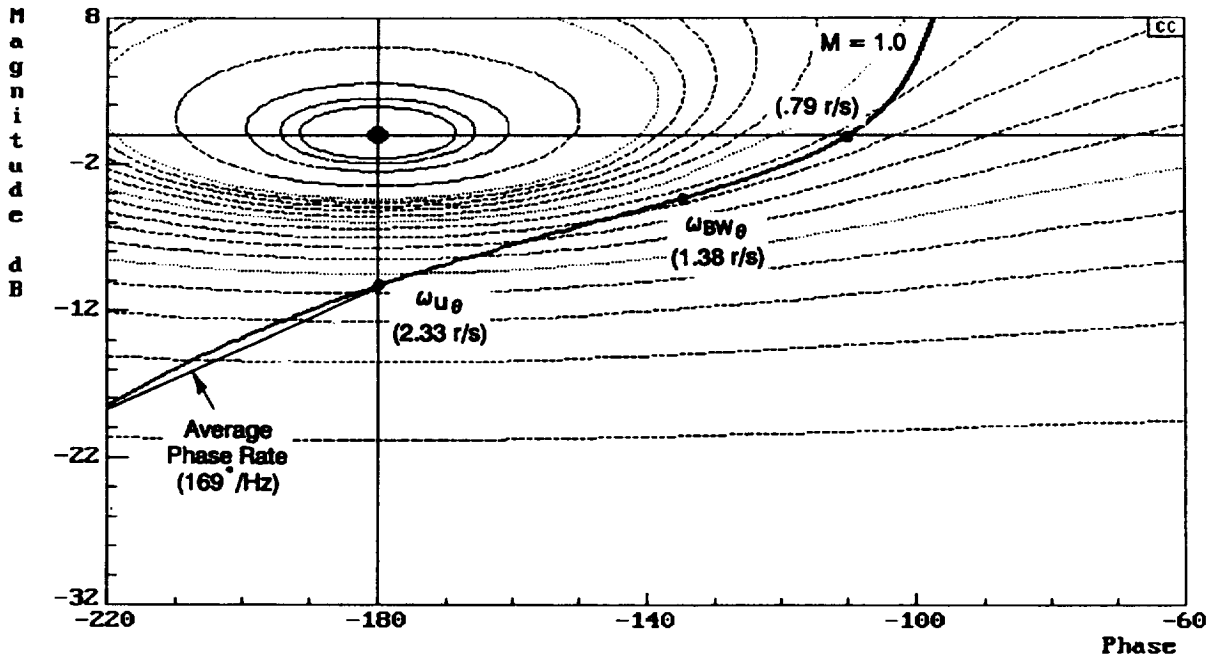
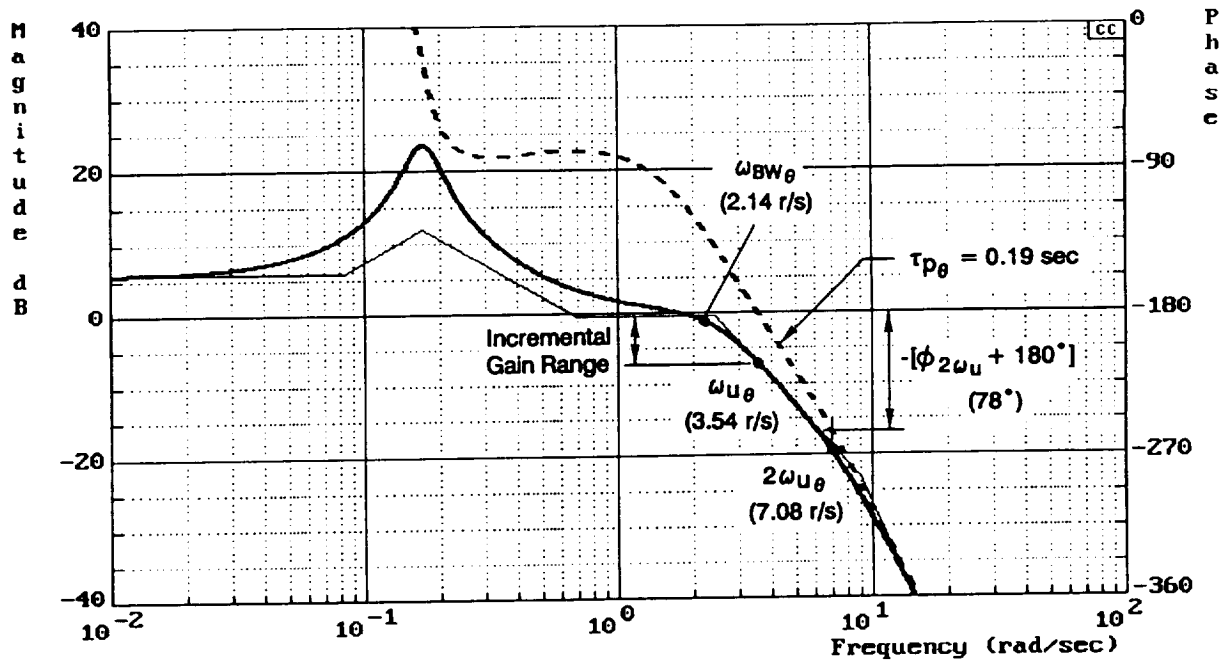

Figure 13b. Configuration: 2-5 {2-1 * 1/(1)} Pilot Ratings: 10/7/10 ; PIOR: 4/4/5 ; $\tau_p = 0.235$ sec
Incremental Gain Range = 9.40 dB (2.95)



$$\frac{1.72E9(.0845)(.699)}{[.15, .17][.63, 2.41][.6, 26][.7, 75]} \frac{1}{(.7, 9)}$$

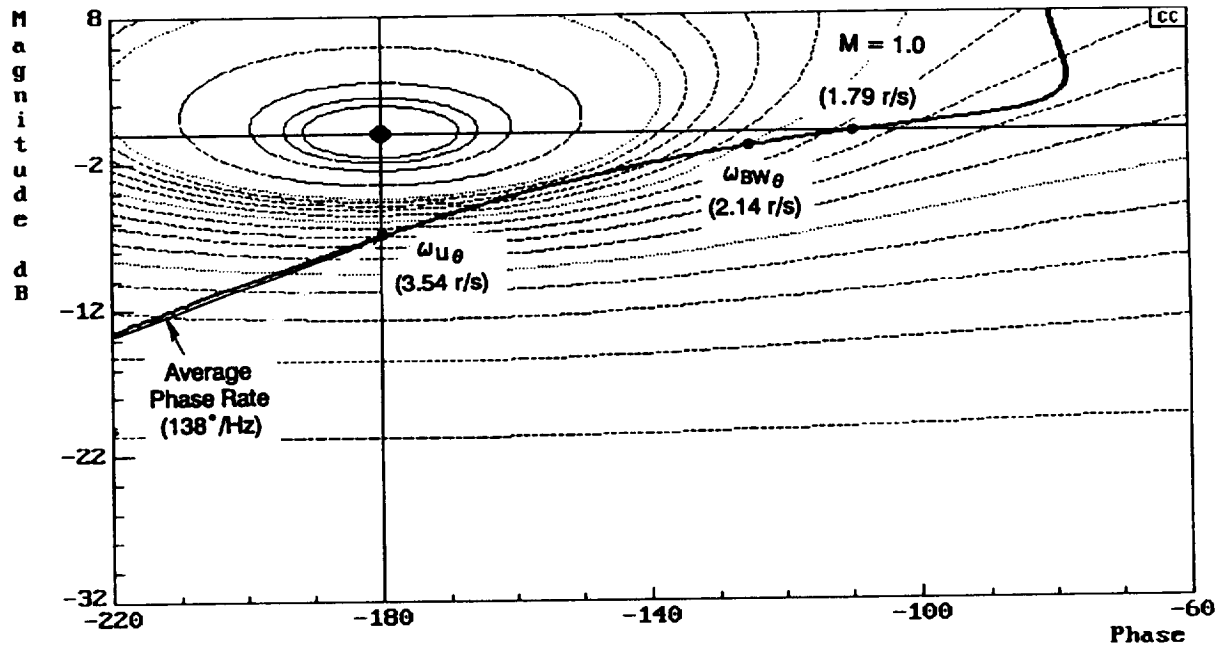
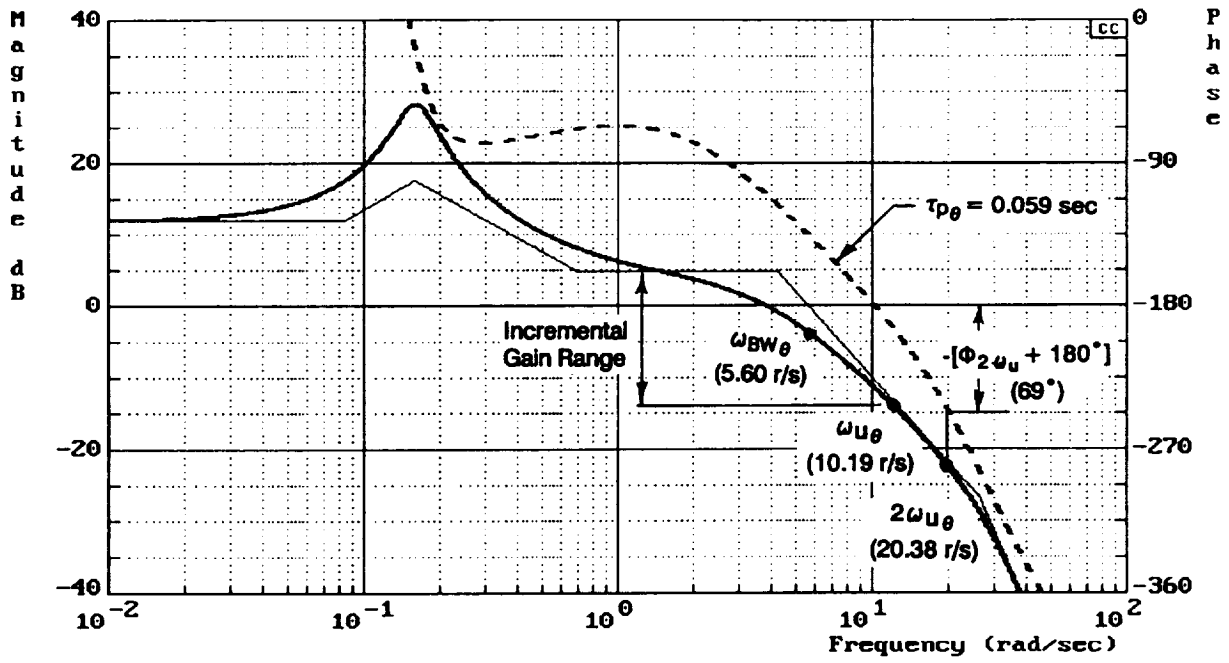

Figure 13c. Configuration: 2-8 {2-1 * 1/[.7,9]} Pilot Ratings: 8/10/8 ; PIOR: 4/4/4 ; $\tau_p = 0.19 \text{ sec}$
Incremental Gain Range = 6.60 dB (2.14)



$$\frac{1.17E8(.0847)(.6987)}{[.17, .16][.97, 4.22][.6, 26][.7, 75]}$$

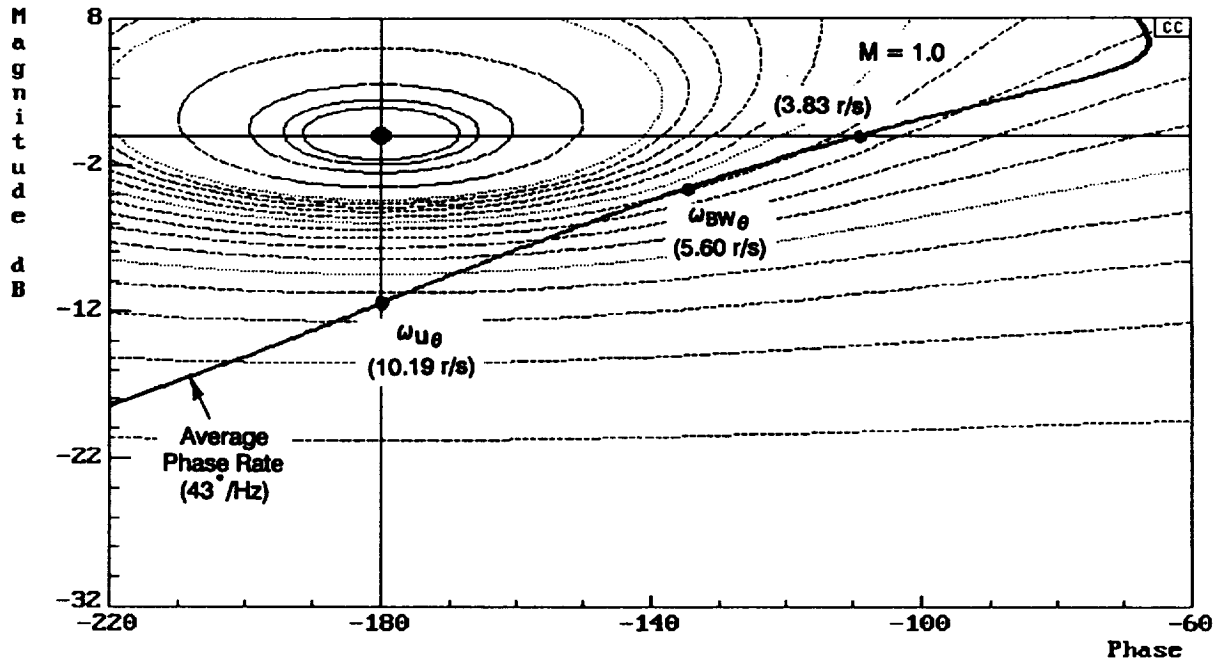
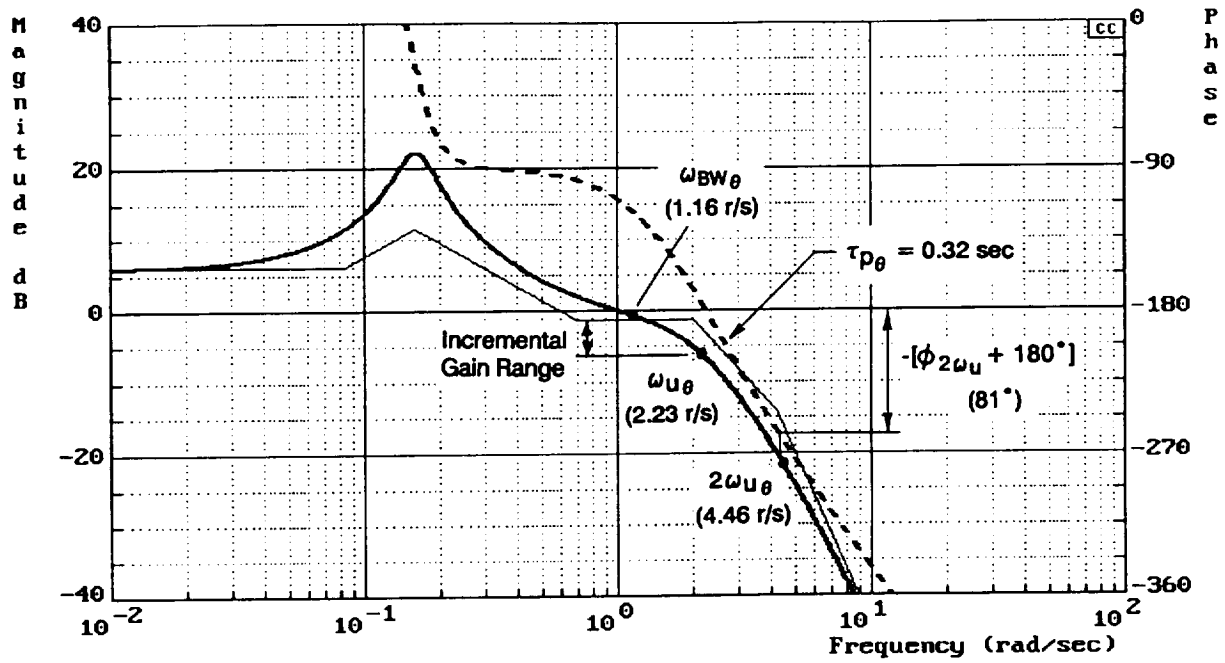

Figure 13d. Baseline Configuration: 3-1 Pilot Ratings: 5/3/4 ; PIOR: 3/2/2 ; $\tau_p = 0.059$ sec
Incremental Gain Range = 16.37 dB (6.58)



$$\frac{2.35E8(.0847)(.6987)}{[.17, .16][.97, 4.22][.6, 26][.7, 75]} \frac{1}{(.7, 2)}$$

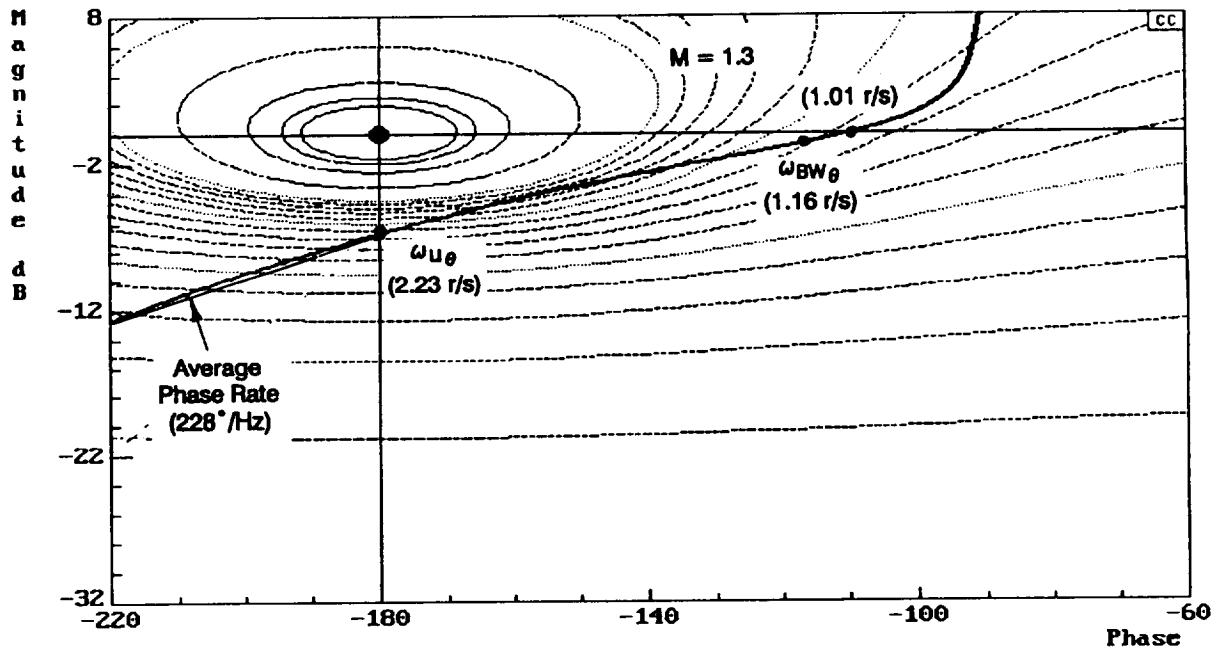
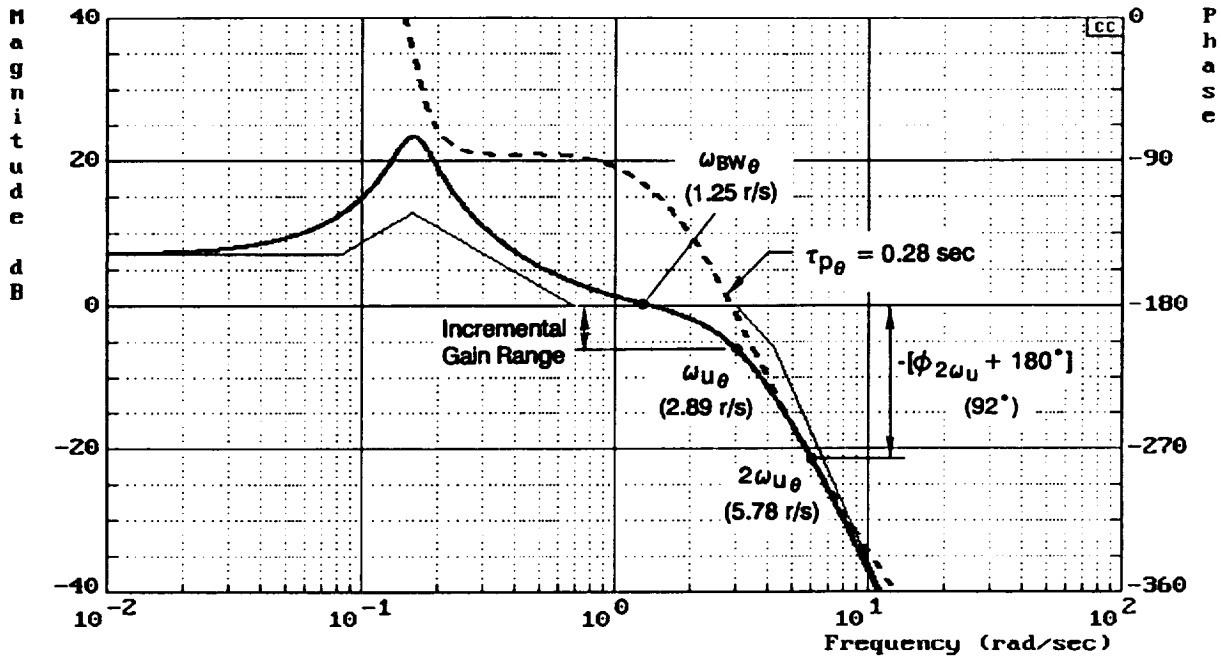

Figure 13e. Configuration: 3-12 {3-1 * 1/[.7,2]} Pilot Ratings: 7/9 ; PIOR: 4/5 ; $\tau_p = 0.32$ sec
Incremental Gain Range = 5.32 dB (1.84)



$$\frac{6.07E8(.0847)(.6987)}{[.17, .16][.97, 4.22][.6, 26][.7, 75]} \frac{1}{(.7, 3)}$$

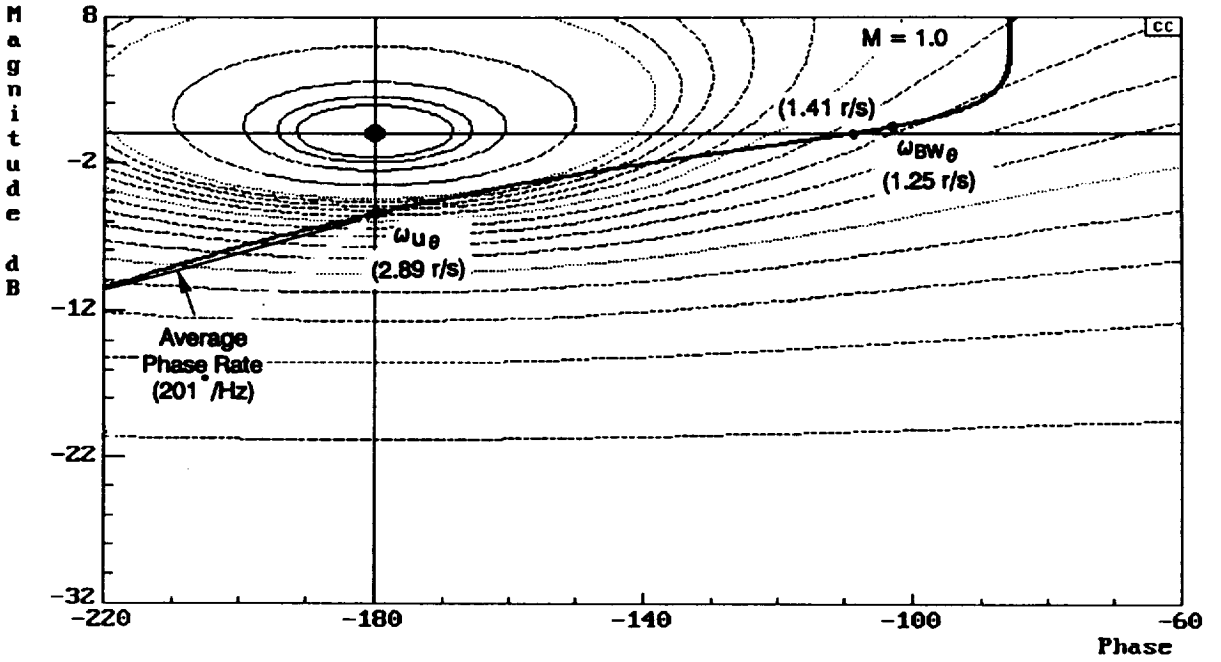
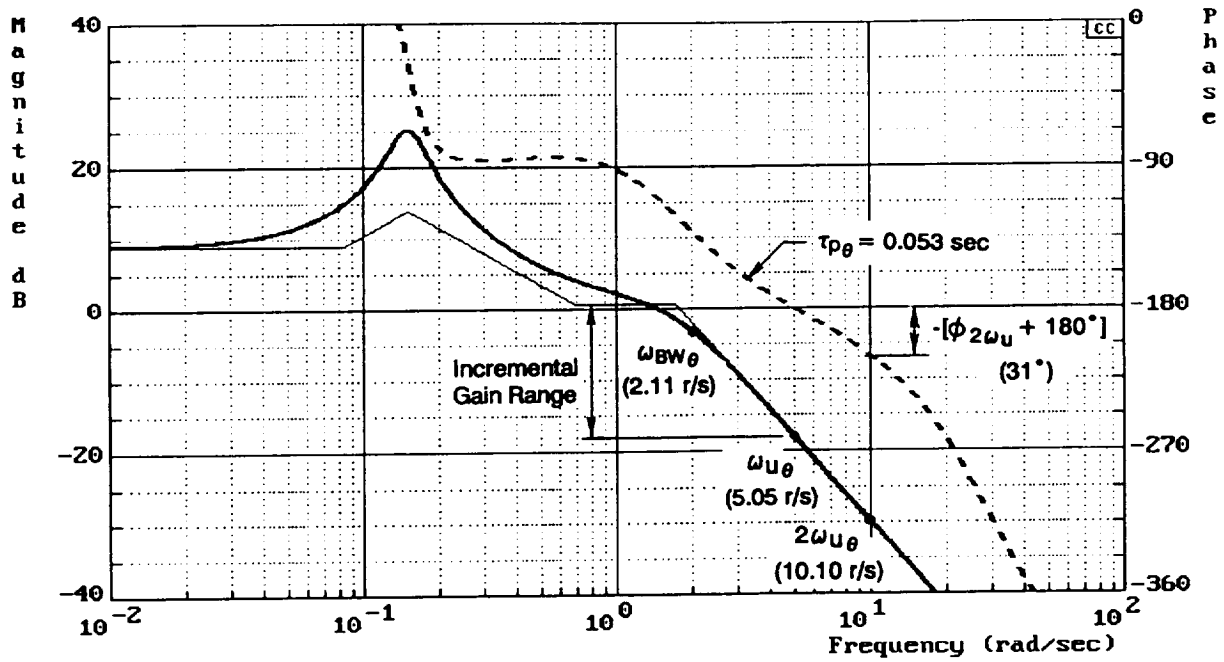

Figure 13f. Configuration: 3-13 {3-1 * 1/[.7,3]} Pilot Ratings: 10/10 ; PIOR: 4/5 ; $\tau_p = 0.28$
Incremental Gain Range = 5.48 dB (1.88)



$$\frac{1.18E7(.0845)(.6989)}{[.16, .15][.68, 1.7][.6, 26][.7, 75]}$$

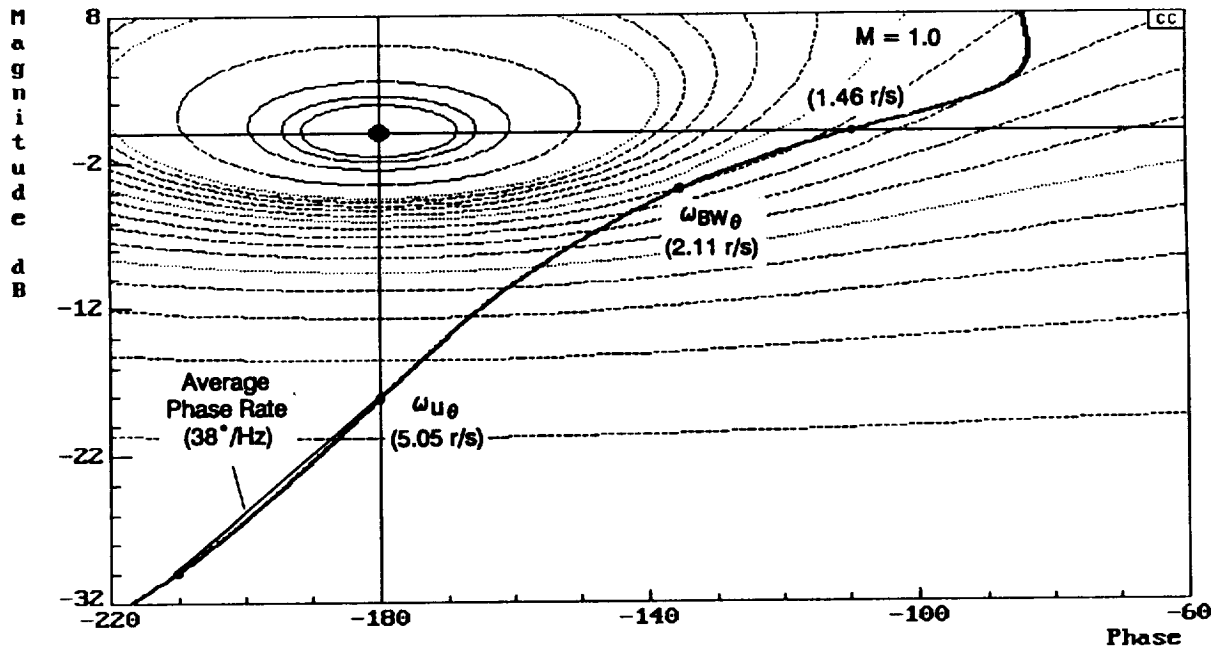
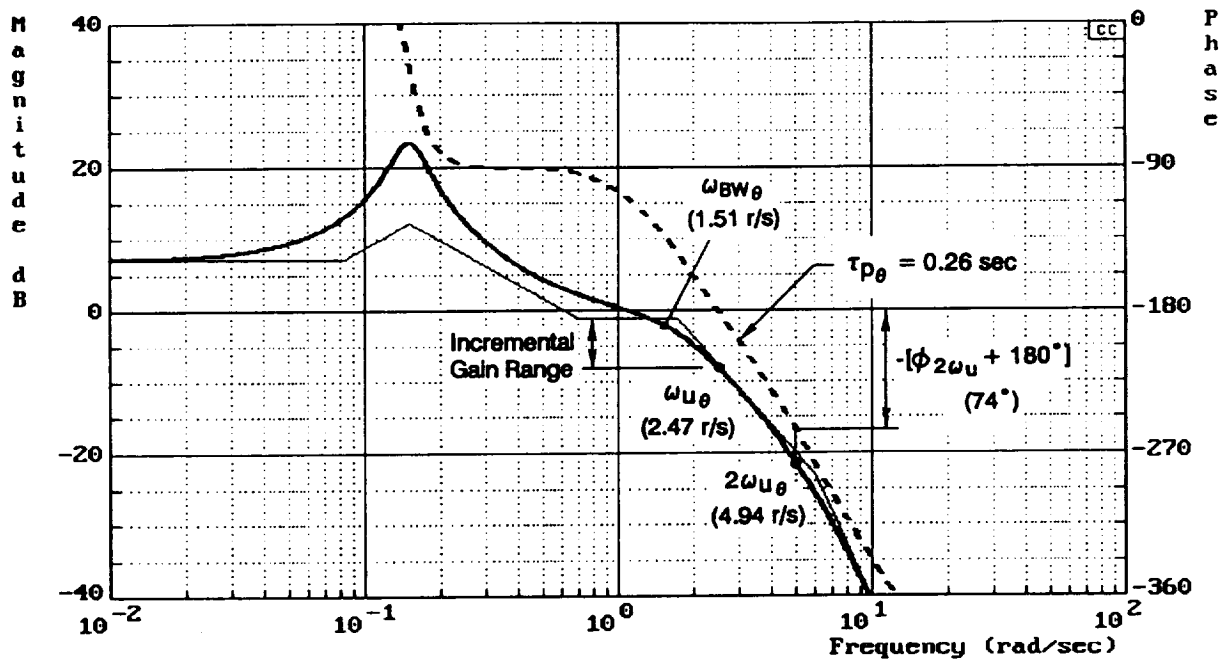

Figure 13g. Baseline Configuration: 5-1 ; Pilot Ratings: 2/5 ; PIOR: 1/1 ; $\tau_p = 0.053 \text{ sec}$
 Incremental Gain Range = 18.71 dB (8.62)



$$\frac{3.45E8(.0845)(.6989)}{[.16, .15][.68, 1.7][.6, 26][.7, 75]} \frac{1}{(.7, 6)}$$

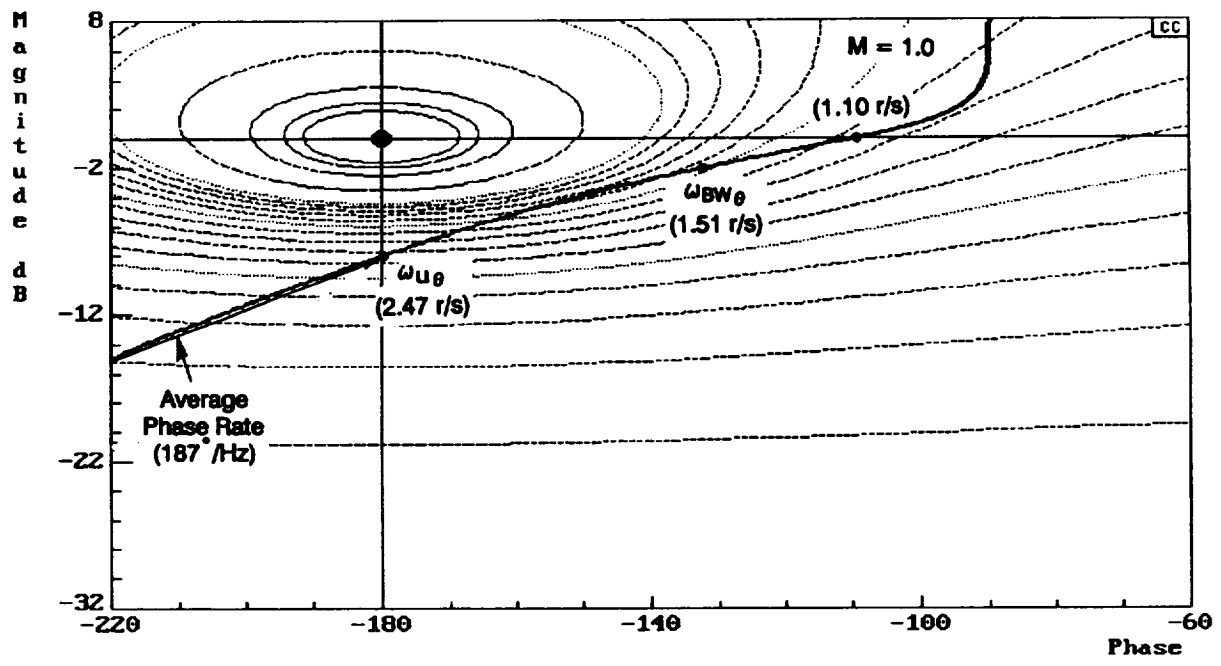
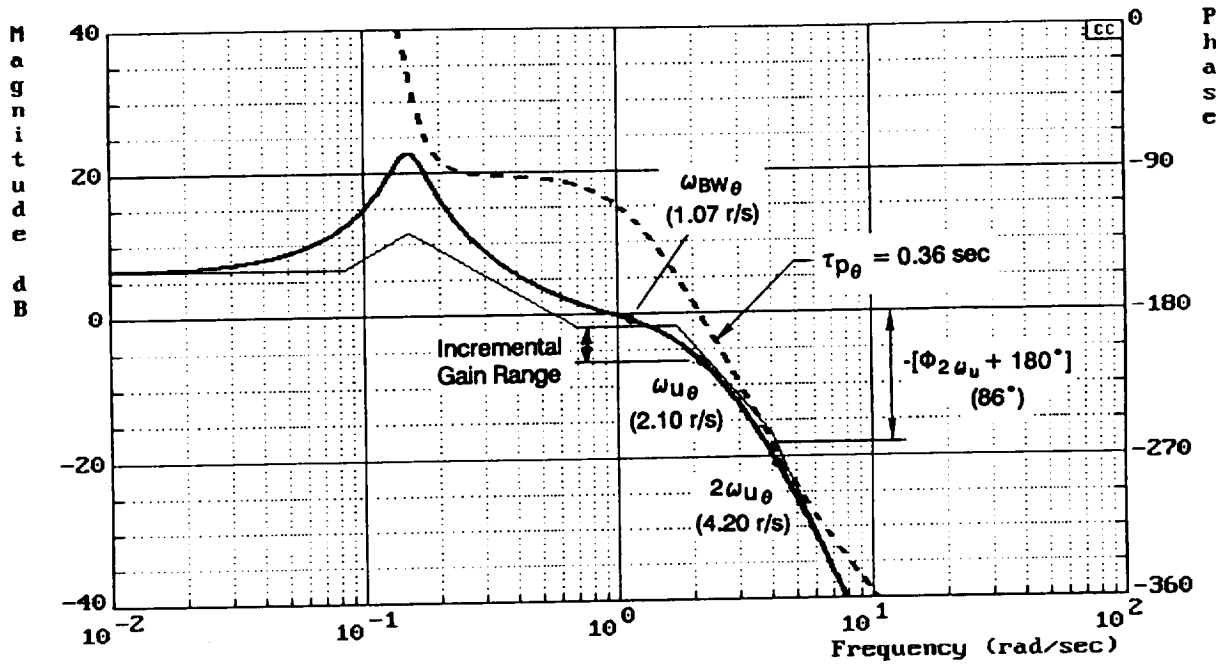

Figure 13h. Configuration: 5-9 {5-1 * 1/[.7,6]} Pilot Ratings: 7/7 ; PIOR: 4/4 ; $\tau_p = 0.26$ sec
Incremental Gain Range = 7.09 dB (2.26)



$$\frac{1.43E8(.0845)(.6989)}{[.16, .15][.68, 1.7][.6, 26][.7, 75]} \frac{1}{(.7, 4)}$$

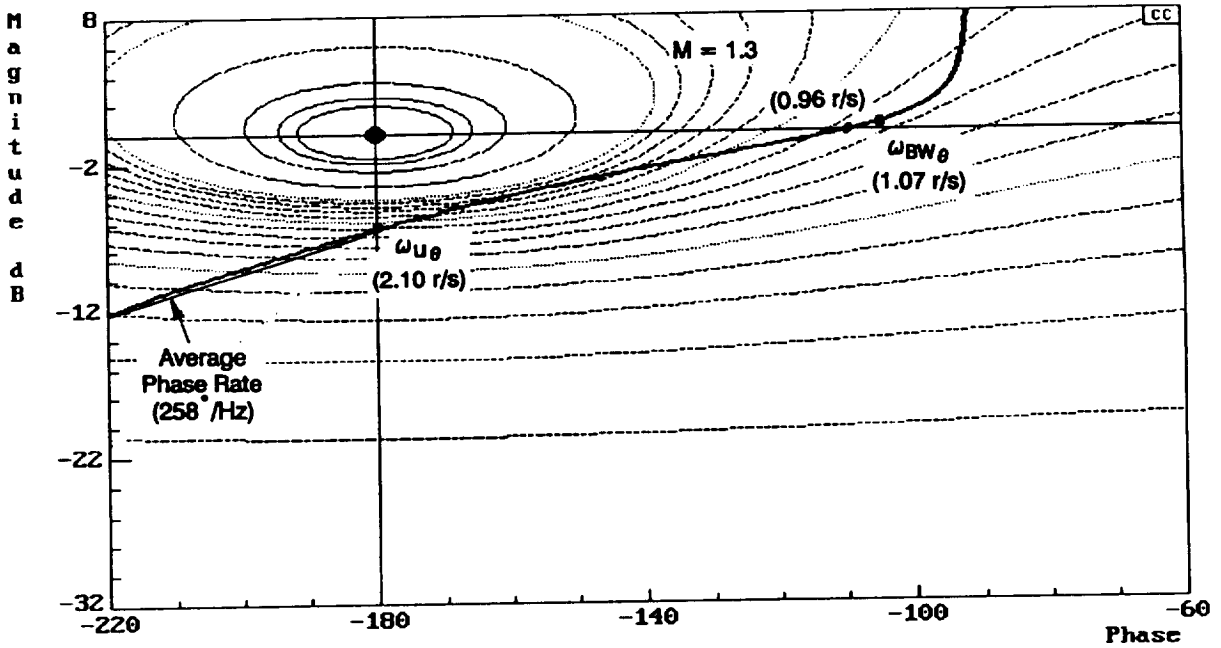

Figure 13i. Configuration: 5-10 {5-1 * 1/[.7,4]} Pilot Ratings: 10/10 ; PIOR: 5/5 ; $\tau_p = 0.36 \text{ sec}$
Incremental Gain Range: 4.76 dB (1.73)

way from a conventional longitudinal airplane; if anything, it is closer to a mid-frequency (near 1 rad/sec) K/s-like characteristic with the nominal short period acting as the added lag. These details are of little consequence for the current focus on severe PIO examples, where all the configurations in the subset apply (although they will come into play immediately below in the discussion of compensatory control).

Table 5 summarizes the key PIO data for the six members of the Severe PIO Subset. Examination of the strip chart recordings in Ref. 72 shows no evidence of rate-limiting or other nonlinear characteristics in the actual PIOs. The PIO amplitudes were similar for all cases, with maximum pitch rates of 4 °/sec and accelerations of ±0.5 g at the c.g. and about ±0.2 g at the pilot location.

Three correlations of the PIO frequencies with possibly appropriate quantities will now be made. The first, shown in Figure 14, connects ω_{PIO} with the neutral stability frequency. The linear regression between the PIO frequencies and the neutral stability frequency, $\omega_{u\theta}$, is

$$\omega_{PIO} = 0.13 + 1.11 \omega_{u\theta} \quad ; r = 0.97 \tag{12}$$

TABLE 5
SEVERE PIO FREQUENCIES DEVELOPED FROM BJORKMAN DATA (REF. 72)
WITH CORRESPONDING VALUES OF $\omega_{u\theta}$ AND ω_R

| Configuration | PIOR | PIO Frequency ω_{PIO} rad/sec | Neutral Stability for θ/F_s $\omega_{u\theta}$ rad/sec | Resonant Frequency ω_R rad/sec |
|---------------|-------|--|---|---|
| 2-5 | 4/4/5 | 2.66 | 2.34 | 2.75 |
| 2-8 | 4/4/4 | 3.77 | 3.53 | 3.83 |
| 3-12 | 4/5 | 2.21 | 2.23 | 2.63 |
| 3-13 | 4/5 | 3.23 | 2.89 | 3.21 |
| 5-9 | 4/4 | 3.48 | 2.48 | 2.91 |
| 5-10 | 5/5 | 2.70 | 2.10 | 2.46 |

Thus, with an offset of 0.13 rad/sec, the PIO frequency is nominally about 11% higher than the frequency which would be predicted for a synchronous pilot interacting with the airplane's attitude dynamics.

The Severe PIO Subset data presented above can also be considered in the context of a high-gain, conventional compensatory control system. This can be done with some precision using such elaborate pilot models as those given in Refs. 5 or 61. Bjorkman herself estimated a resonant frequency, ω_R , using the recommendations of Ref. 5. This was presumably done before the flight tests were run, so these are

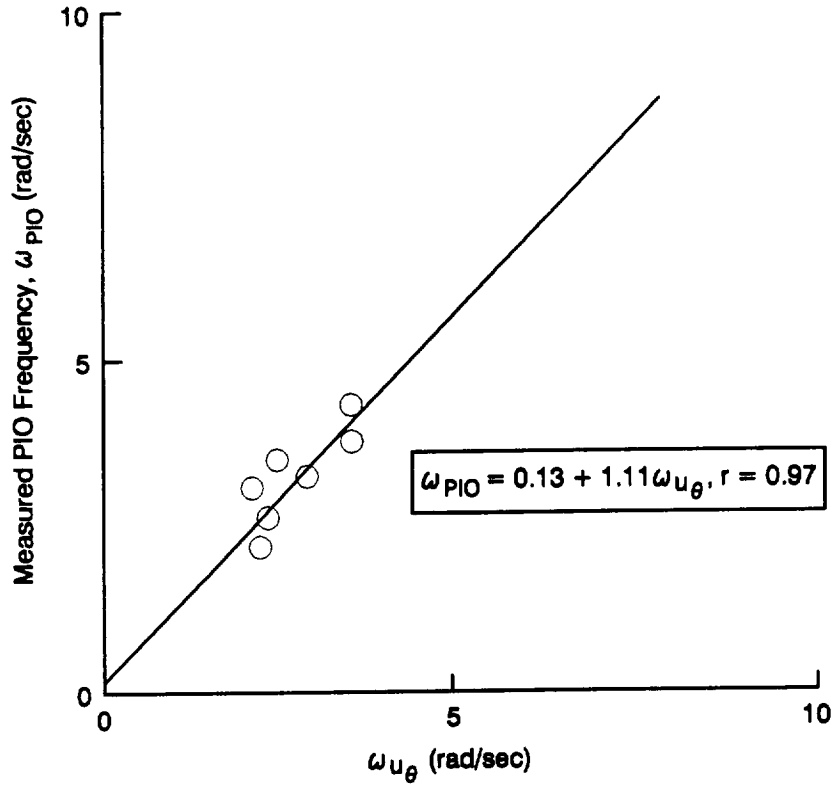

Figure 14. Comparison of Flight-Based PIO Frequencies with Neutral Stability of θ/Fs

cited here in Table 5. A plot showing PIO frequency as a function of the estimated attitude control resonant frequency is shown in Figure 15. For these data a linear regression is,

$$\omega_{PIO} = 0.02 + 1.01 \omega_R ; r = 0.97 \quad (13)$$

This is, of course, an excellent correlation! It is essentially right on for this restricted data set.

Finally, the crossover model can be used directly to provide a very simple, albeit most approximate, set of estimates. To do this, the higher-frequency effective lags are lumped into a composite effective delay, τ_{hi} , added to an appropriate pilot delay, τ_h , to estimate a composite open-loop system time delay, τ_e . The neutrally-stable frequency for the closed-loop pilot-vehicle system is then computed using Eq. 6. The consequent data are summarized in Table 6, and depicted graphically in Figure 16. A linear regression gives,

$$\omega_{PIO} = 0.33 + 0.97 \omega_{u_{cm}} ; r = 0.94 \quad (14)$$

Here the offset (0.33) is greater but the proportionality, 0.97, is closer to 1.0 than for the interpretations based on the synchronous pilot assumption. This result indicates that, although the treatment is at the

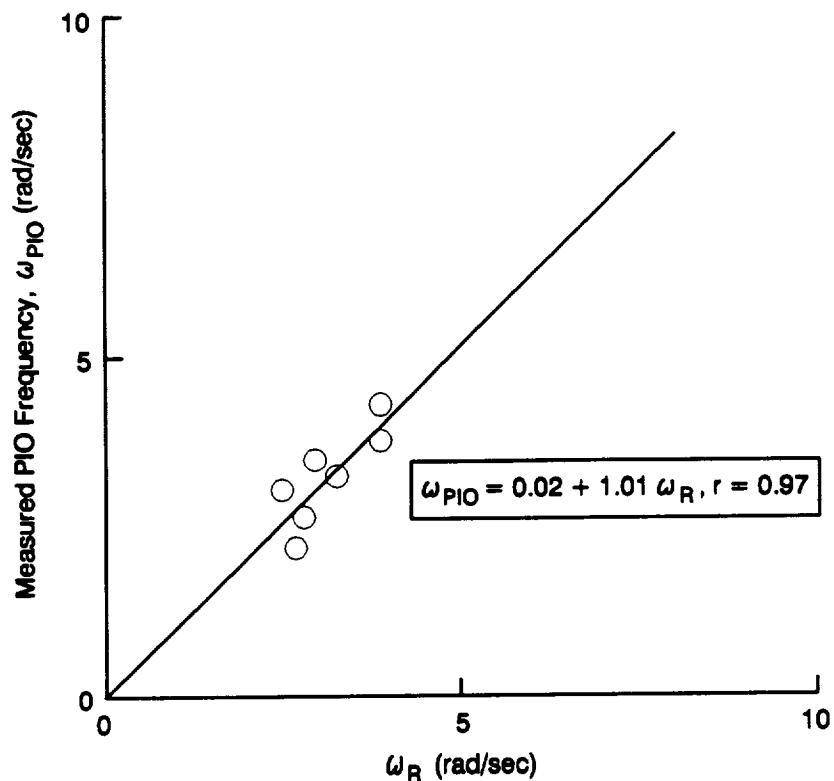

Figure 15. Comparison of Flight-Based PIO Frequencies with Compensatory System Resonant Frequencies

TABLE 6

SEVERE PIO SUBSET WITH CROSSOVER MODEL

| Configuration | Estimate of τ_{hi} | | τ_e $\tau_{hi} + 0.25$ | Neutral Stability $\omega_{u_{CM}} = \pi/2\tau_e$ | PIO Frequency ω_{PIO} |
|---------------|--------------------------------------|-------------|--------------------------------|--|---------------------------------|
| | $\frac{2\zeta/\omega}{\text{BASIS}}$ | τ_{hi} | | | |
| 2-5 | $\frac{2(0.64)}{2.41}$ | 0.53 | 0.78 | 2.01 | 2.66 |
| 2-8 | $\frac{2(0.7)}{9}$ | 0.156 | 0.406 | 3.87 | 3.77 |
| 3-12 | $\frac{2(0.97)}{4.22}$ | 0.46 | 0.71 | 2.21 | 2.21 |
| 3-13 | $\frac{2(0.97)}{4.22}$ | 0.46 | 0.71 | 2.21 | 3.23 |
| 5-9 | $\frac{2(0.7)}{6}$ | 0.233 | 0.48 | 3.29 | 3.48 |
| 5-10 | $\frac{2(0.7)}{4}$ | 0.35 | 0.60 | 2.62 | 2.7 |

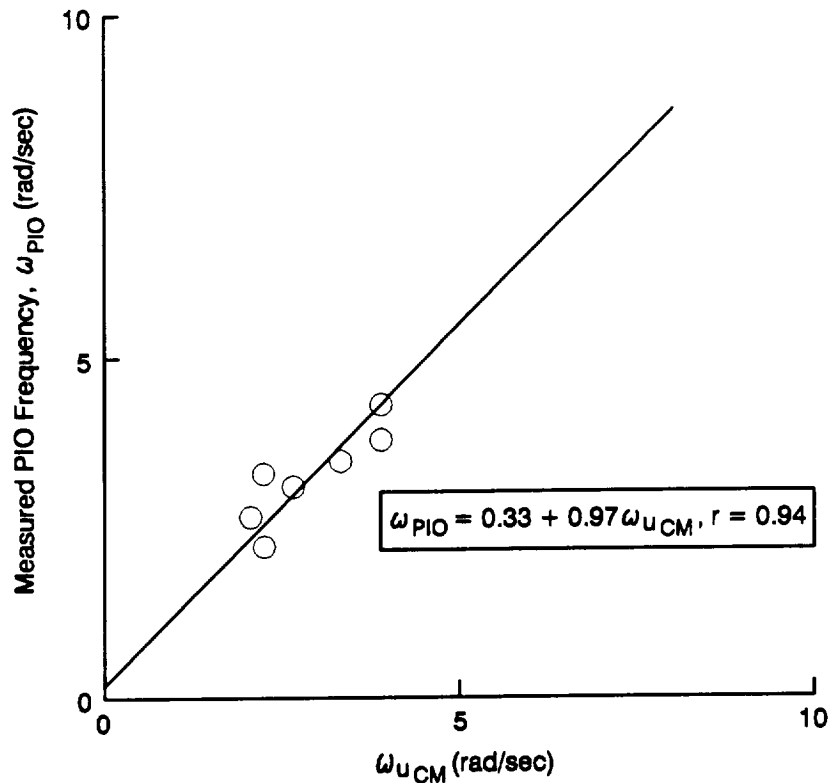

Figure 16. Comparison of Flight-Based PIO Frequencies with Compensatory System Neutral Stability Frequency Based on the Crossover Model

level of very first-order approximations, the elementary crossover model appears to capture enough of the fundamentals to provide a reasonable estimate for the PIO frequency.

The above discussions and analysis indicate that the crossover and more precise pilot models for compensatory control and the synchronous pilot model can all give relatively good estimates for the PIO frequency for these particular data. The synchronous pilot assumption has a major advantage in that only effective aircraft dynamics need to be considered; albeit with the proviso that the PIO frequency estimate will be high. More precise estimates for these data seem to require the assumption of a compensatory model. A major reason that these results are so close together is the overwhelming impact of the added lags underlying the PIO tendencies. For other PIO sources there can be major differences in analyses conducted using compensatory and synchronous assumptions.

2. Governing Principle for Good Flying Qualities – Tolerance to Pilot Compensation Variations

To better appreciate the qualitative and quantitative aspects of PIOs due to excessive lags they must be considered in the larger context of closed-loop pilot-aircraft interactions in general. These interactions, whether favorable or unfavorable, are part of the domain of "Flying Qualities." An aircraft which exhibits a high degree of PIO susceptibility clearly has very poor flying qualities. Starting at the other extreme,

the most fundamental attribute of effective airplane dynamics which possess excellent flying qualities is tolerance to adjustments in pilot dynamic characteristics in demanding, high-urgency, closed-loop flying tasks. In the explicit statements of the Cooper-Harper rating scale describing Level 1 flying qualities,

"Pilot Compensation is not a factor for desired performance" (PR's of 1 and 2), and "Minimal Pilot Compensation Required for Desired Performance" (PR of 3).

Although there are a variety of detailed pilot-vehicle system factors involved in pilot rating (e.g., Ref. 75), the "Tolerance to Pilot Compensation Variations" is of such central and overriding importance that it can be taken as the governing and guiding principle in considering both favorable and unfavorable (e.g., PIOs) pilot-vehicle interactions. To elaborate on this theme several examples will be treated below:

a. Idealized Good and Bad Effective Vehicle Characteristics

For closed-loop full-attention operations the ideal controlled-element dynamics is $Y_c = K_c/s$. This form requires no pilot lead or lag equalization for compensatory operations (the crossover model is "made good" with pilot dynamics which approximate $Y_p = K_p e^{-\tau_p s}$). Further, it supports a range of pilot gains from zero to an octave or so below ω_u with only minor changes in the basic dynamic form of the closed-loop system. The attainable closed-loop system bandwidth and time response performance is, in fact, limited only by the pilot's effective lag, τ_h . In terms of the pilot-vehicle system output/input properties (Fig. 1) for low and moderate open-loop gains the dominant closed-loop mode will be approximately,

$$\frac{M(s)}{I(s)} \doteq \frac{1}{(s/\omega_c + 1)}, \quad \omega_c = K_p K_c \quad (15)$$

For this ideal controlled element the pilot has maximum latitude to vary gain, K_p (and thus ω_c), to adjust the closed-loop system response and accuracy as needed to meet varied demands while not materially changing the form of the closed-loop system dynamics. As the pilot attention level, task urgency, or aggressiveness calls for gain modification, the crossover frequency, ω_c , will increase or decrease proportionally, and the dominant closed-loop system time constant, $1/\omega_c$, will wax and wane in corresponding fashion. Thus, there is a very wide range of closed-loop system response properties available which are effected in direct proportion to pilot effort.

Consider as the other extreme a set of effective aircraft dynamics characteristics in the region of pilot-vehicle system crossover that requires a great deal of pilot lead as well as exquisitely precise adjustment of the pilot's equalization and gain to approximate the crossover law and to close the loop in a stable manner. The pilot may be able to exert adequate closed-loop control, but the dynamic quality and even the closed-loop system stability require that the pilot's describing function, Y_p , be precisely tuned to offset the controlled element deficiencies in the crossover region. In the language of the Cooper-Harper Scale,

the pilot's compensation in this case can range from "extensive" (PR = 6) if adequate performance can be attained at all, to "considerable" (PR = 8) or "intense" (PR = 9) if retention of control itself is the only issue.

PIO potential fits very nicely in this framework. Clearly the ideal K_c/s vehicle dynamics (with the aircraft gain, K_c , set at an optimum value) is very forgiving and has very low PIO potential, whereas the other example will have a high PIO potential in urgent, high-gain tasks.

b. Two Specific Examples

A more concrete and quantitative appreciation of these same considerations can be illustrated using two examples from the LAHOS data (Ref. 76). These have been selected to have identical low-frequency characteristics (classical short period aircraft modes) and high frequency (e.g., actuation) modes but with markedly different properties in the mid-frequency region (around a phase angle of -180°) pertinent to synchronous pilot (pure gain) PIOs.

Figures 17 and 18 present both Bode and gain-phase forms of the effective aircraft frequency responses. The short period properties and the very highest frequency modes at [0.6, 26] and [0.7, 75] are identical. The differences are: Case 2-C includes a lead-lag, (5)/(10); whereas Case 2-10 has a command filter lag, 1/[0.7, 4]. The lead-lag extends the region which approximates a "K/s-like" character of the amplitude ratio for 2-C, while the command filter lag serves to reduce pilot high frequency commands and remnant (pilot-induced noise) for 2-10. The Bode plots readily show such obvious differences as:

Configuration 2-C:

The lead-lag equalization extends the amplitude ratio frequency range of roughly "K/s-like" character, permitting an increased maximum crossover frequency. These features lead to a much larger available range for pilot gain adjustment.

The "attitude bandwidth," which reflects the closed-loop pilot-vehicle properties attainable without significant pilot equalization, is quite large.

The phase shift slope around the -180° point is shallower than that for the other configuration, indicating less dramatic change in phase lag with frequency in this region.

Configuration 2-10:

The command filter significantly reduces the frequency range over which the amplitude ratio approximates a "K/s-like" character, and creates a major addition to the phase lag in this and higher-frequency regions. These features lead to a lower maximum crossover frequency and reduced range for pilot gain adjustment.

$$\frac{\theta}{F_s} = \frac{4.41E+7(0.7)}{\underbrace{(0)[0.57, 2.3][0.6, 26][0.7, 75]}_{\text{Baseline Short-Period + High-Frequency}}} \underbrace{\frac{(5)}{(10)}}_{\text{Lead-Lag}}$$

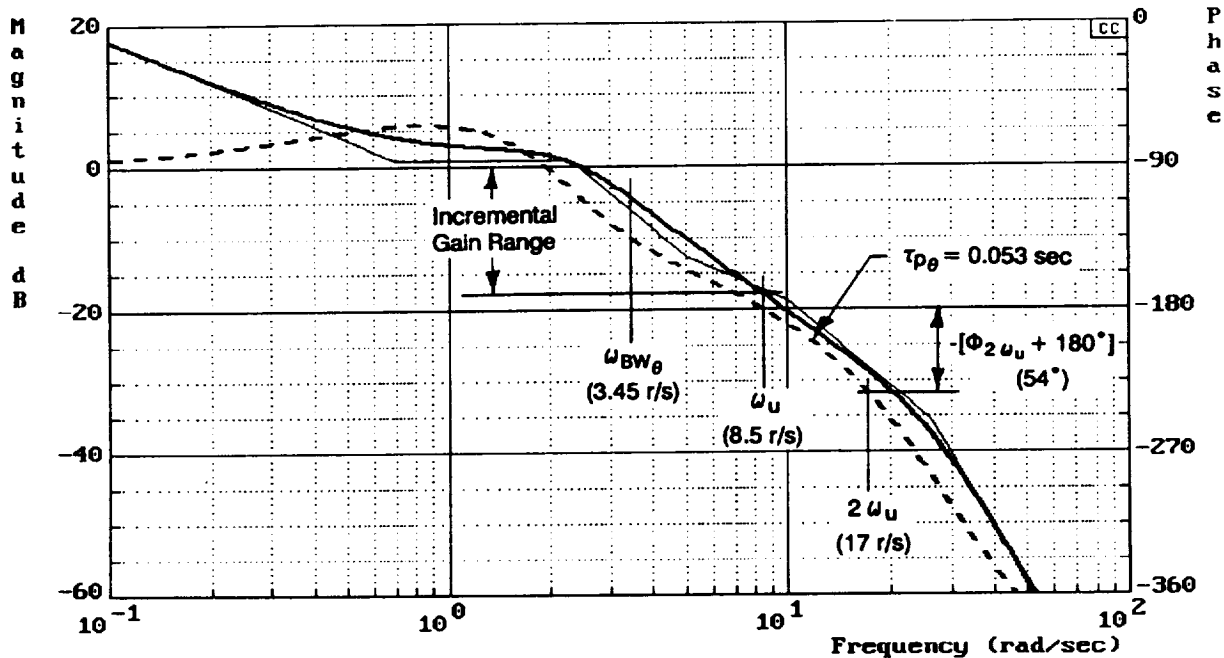

(a)

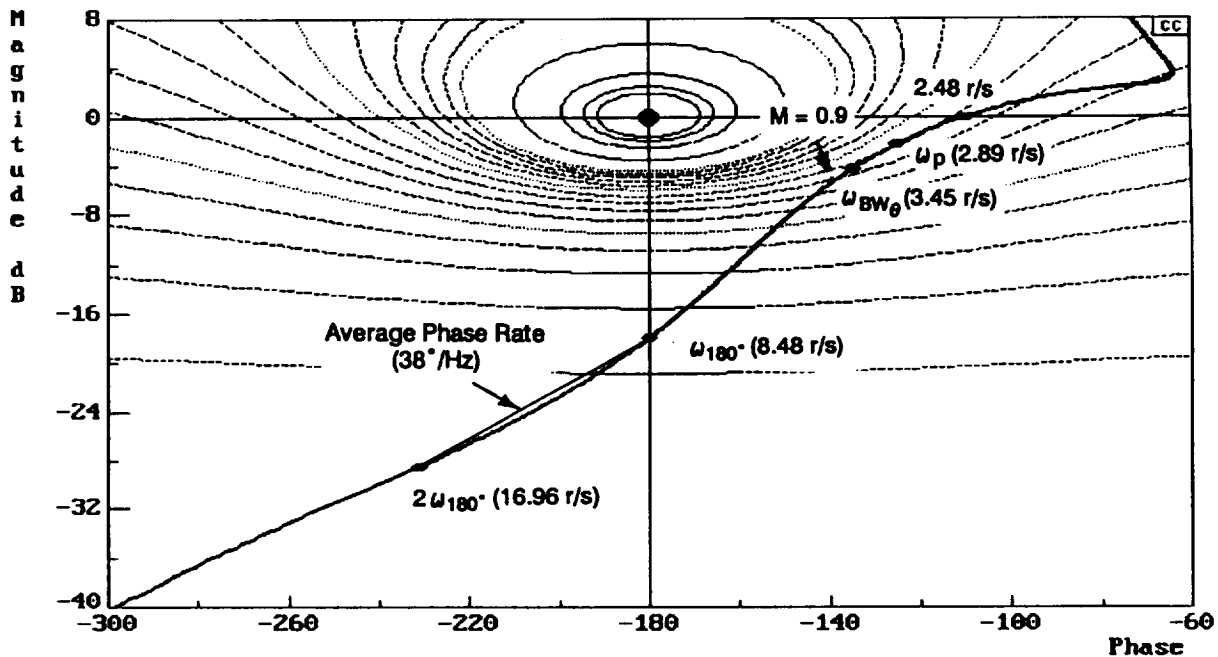

(b)

Figure 17. Bode and Gain Phase/Nichols Plots for LAHOS Case 2-C

$$\frac{\theta}{F_s} = \frac{2.72E+8(0.7)}{\underbrace{(0)[0.57, 2.3][0.6, 26][0.7, 75]}_{\text{Baseline Short-Period + High-Frequency}}} \underbrace{1}_{\text{Command Filter}}_{[0.7, 4]}$$

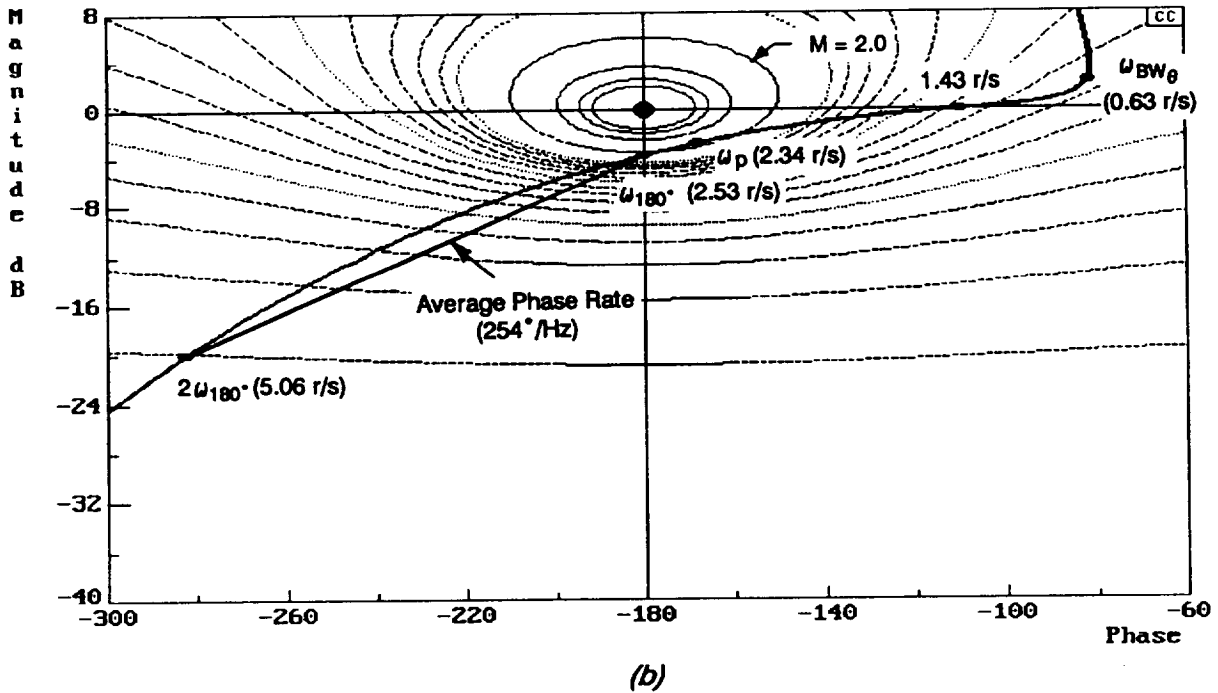
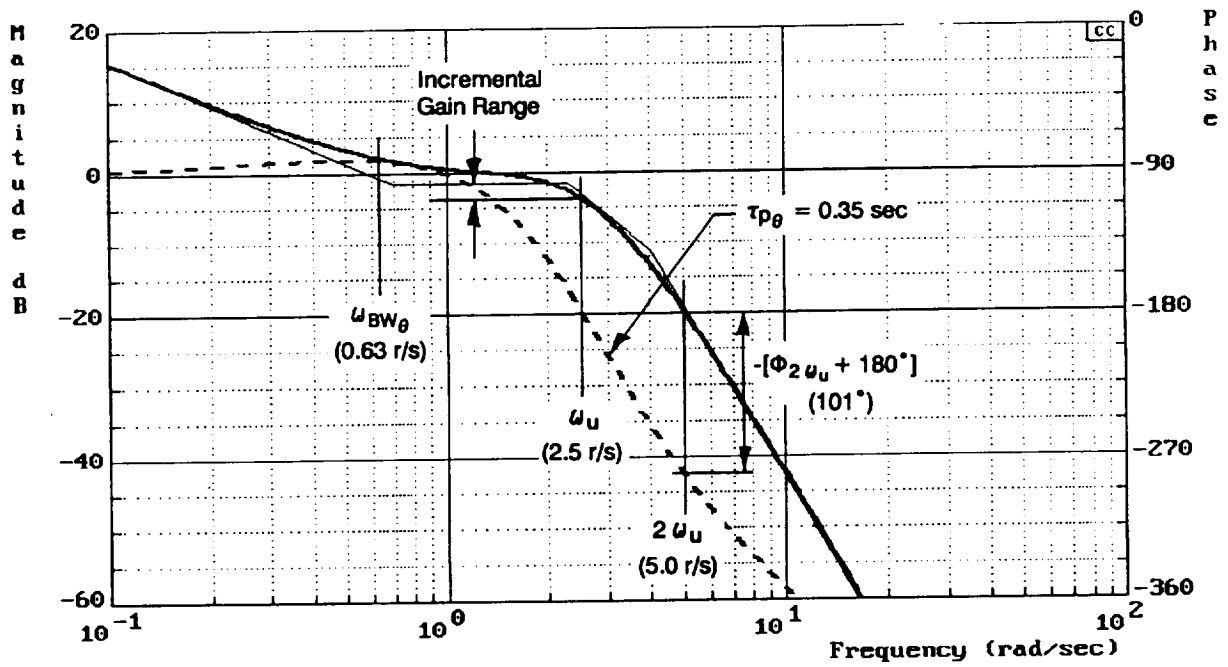

Figure 18. Bode and Gain Phase/Nichols Plots for LAHOS Case 2-10

The command filter characteristics have a great impact on the "attitude bandwidth," forcing it to be determined here on the basis of a 6 dB gain margin rather than the more usual phase margin of 45° . This shift in bandwidth measurement criteria reflects the magnitude of usable closed-loop system bandwidth achievable without major pilot equalization. To satisfy the crossover model here, the pilot would have to generate a lag near $1/T_{\theta_2}$ followed by a higher frequency lead; but the very large lag introduced by the filter is such as to make such pilot-generated equalization of very limited if any value.

The phase curve in the region of -180° is very steep, reflecting the impact of the major mid-frequency time lags introduced by the command filter.

The gain-phase representation on the Nichols Chart provides another useful perspective. To place the two plots on a common gain basis, the gain phase plots are adjusted so that zero dB occurs when the phase is -110° . For a pure gain loop closure this would correspond to a phase margin of 70° . As already noted, this normalization is arbitrary, but follows a practice suggested elsewhere (e.g., Ref. 1). Even with this large phase margin, the peak magnification ratios of the closed-loop properties revealed by the M circles exhibit large differences (2.23 or 7 dB for 2-10 versus 0.92 or -0.75 dB for 2-C), which, in turn, indicates a significant difference in potential closed-loop system resonant frequency whenever the task demands require the pilot to maximize the closed-loop bandwidth. In this same connection, the frequencies corresponding to the peak magnification ratio, at 2.34 rad/sec for 2-10 and 2.9 rad/sec for 2-C, again reflect the much poorer closed-loop pilot-vehicle system performance potentially available for configuration 2-10.

The Nichols Chart representation is particularly revealing for assessment of conditions near potential PIO frequencies for synchronous pilot activity. Around the -180° phase region the two plots exhibit quite different shapes: 2-10 shallow, and 2-C steep. For 2-C, a small change in pilot gain will create far less change in closed-loop system peak magnification than the same change for 2-10. The "phase rate" is a useful measure proposed in Ref. 7 to quantify this property. It will be recalled that, when taken as an "average phase rate" based on the phase difference between the phase at ω_{180} and that at twice this frequency, divided by ω_{180} , the phase rate in degrees/Hertz and the phase delay, τ_p , are related by Eq. 11.

Some of these qualitative observations can be quantified using such measures as those called out on the graphical representations and summarized in Table 7.

TABLE 7

SOME SUMMARY MEASURES OF FREQUENCY DOMAIN CHARACTERISTICS

| Property | Case 2-C | Case 2-10 |
|--|---------------------|-------------------|
| Maximum Attainable Crossover, ω_u (Neutral Stability) | 8.5 rad/sec | 2.5 rad/sec |
| Incremental Gain Adjustment Range (From $1/T_{\theta_2} - \omega_{sp}$ Shelf) | 18 dB (7.94) | 2dB (1.25) |
| Attitude Bandwidth, ω_{BW} | 3.45 rad/sec | 0.63 rad/sec |
| Phase Delay, τ_p | 0.053 sec | 0.353 sec |
| Peak Magnification Ratio, M_p | -0.75 dB (0.917) | 6.96 dB (2.23) |
| Closed-loop Resonance (Frequency for M_p) | 2.89 rad/sec | 2.34 rad/sec |
| Average Phase Rate | 38.2°/Hz | 254 °/Hz |

Taken altogether, these measures portray the characteristics of the pitch attitude features in the frequency regime ranging from the nominal high-gain crossover region to the potential PIO region. Some measures serve to quantify closed-loop pilot-vehicle system performance attainable (e.g., attitude bandwidth, closed-loop resonance characteristics - frequency and peak magnification ratio) without pilot compensation. These and other parameters, such as the incremental gain adjustment range, also bear on the sensitivity to pilot gain adjustments and variations. Some measures reflect features in the particular region of synchronous PIO potential (e.g., instability frequency, phase rate, nominal M_p , etc.).

Quantitative measures relating to permissible pilot gain variations require reference levels. For the example configurations considered here there are no convenient absolutes, so the references chosen are arbitrary. The adjustment on the gain-phase plot normalizing the 0 dB point to coincide with a phase shift of -110° is based on practice elsewhere (e.g., Ref. 1). The measurement of the incremental gain range starting from the $1/T_{\theta_2}$ to ω_{sp} shelf asymptote was selected as appropriate only for comparing the two configurations at hand, and has no particular cachet for generalization. (This same measure is given for the Bjorkman data on Figures 13a-i.) In systems which are conditionally stable an arbitrary normalization is not needed, and a "Total Available Gain Range" can be defined which provides similar information.

Although the measures tabulated provide a convenient quantitative summary, the graphical presentations themselves provide a better basis for gaining an appreciation of the total picture ranging from flying qualities in general to PIO potential or other issues in particular. They are, of course, the underlying basis for the summary measures tabulated above as well as for other measures that have or may

be proposed for specific predictive or assessment criteria. The development of insights pertinent to specific issues, such as the potential impact of pilot gain variations, are a matter of clearcut interpretation of the graphical representations. They also serve as useful tools to assess possible design modifications for improvement of performance or alleviation of PIO potential, or to provide particular focus on specific quantitative characteristics which may define PIO potential, etc.

Returning now to the general principle and its ramifications, clearly Configuration 2-C has characteristics which in all respects are greatly superior to those of Configuration 2-10. The high-urgency attitude-control flying qualities in general are obviously much better. And, more particularly, the high-gain, task urgency properties of 2-C are generally inimicable to the development of PIO, while those of 2-10 can only be considered to be PIO-prone. It should therefore come as no surprise that the in-flight-based pilot ratings for 2-C were 2.5, while 2-10 was a 10! The PIO ratings were PIOR of 1 and 4, respectively. These arguments, and indeed the examples chosen to illustrate them, give credence to the prescriptions for PIO prevention given in Ref. 7. They can also be used to support the criteria proposed in Refs. 1, 5, 6, and 8.

3. The Space Shuttle Orbiter Approach and Landing Tests

This section has thus far been devoted to the examination of the effects of excessive lags on PIO phenomena which can be treated and understood using linearized effective vehicle and quasi-linear pilot dynamic characteristics. The flight data presented have all derived from controlled experiments in which PIOs were expected or even sought. The motivation for such studies stems from flight operations in which PIOs were not expected, and were definitely not sought!

One of the most influential PIOs in history occurred on October 26, 1977, when the shuttle Enterprise performed the very first approach and landing to a normal runway as part of a test series entitled "Approach and Landing Tests" or ALT. There was a very large crowd at Edwards, including such dignitaries as the Prince of Wales, and extensive television coverage gave a great deal of visibility to the PIO sequence which occurred. So, as might be expected, this abnormal approach and landing motivated extensive studies of the phenomenon.

As shown in Figure 19 there were two longitudinal PIO modes (an attitude mode at 3.5 rad/sec and a path mode at 1.9 rad/sec). The fact that both were present was a central factor in the analysis (Ref. 18). Although the details of the orbiter PIO are quite complicated, path control was critical on this first shuttle landing on a conventional runway. Very tight attitude control was required to enable a similarly tight path loop. In the event, both loops were closed at or very near their stability limits. Thus, while the interactions between path and attitude, task urgency, and some rate limiting were all involved, the primary

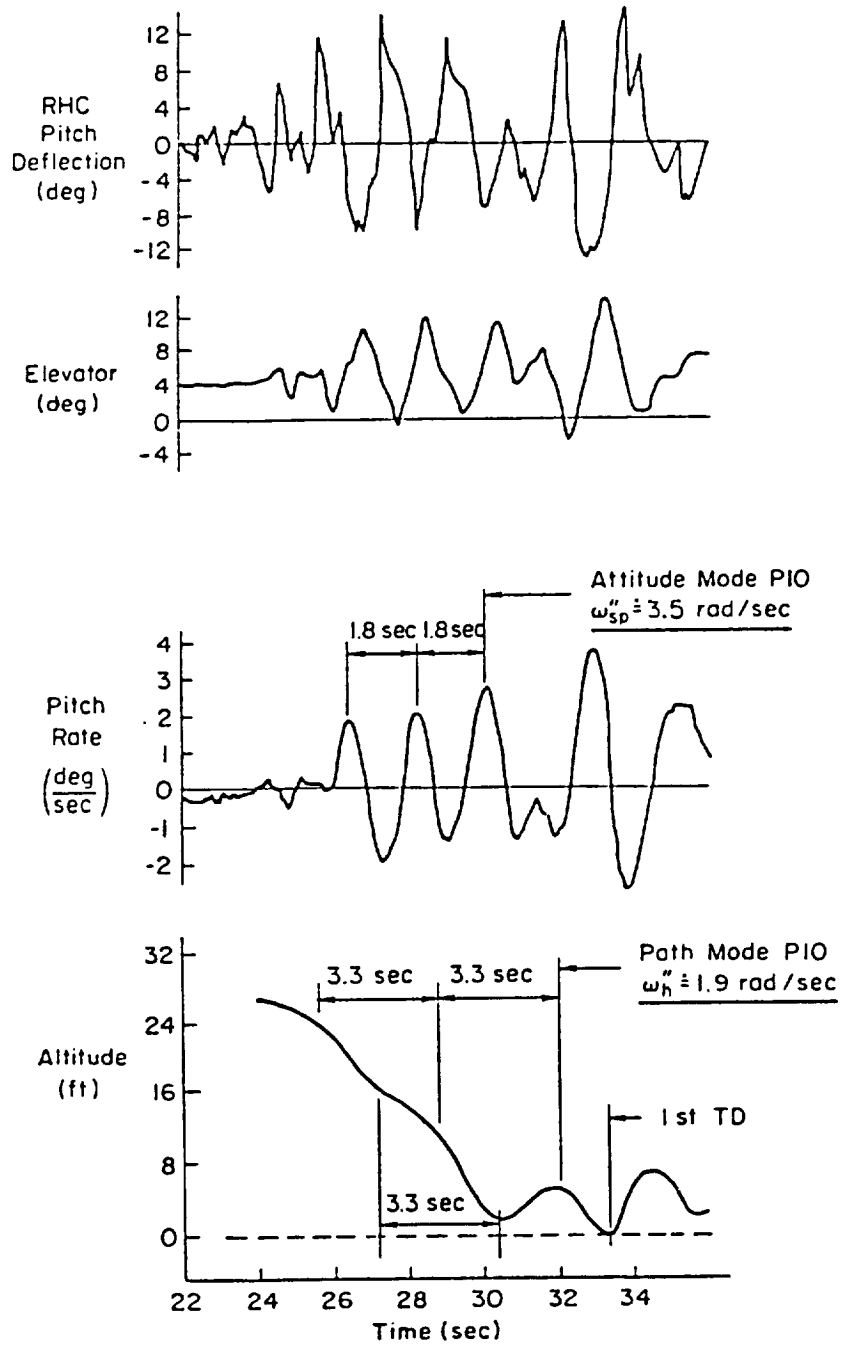

Figure 19. Shuttle Orbiter PIO (Ref. 18)

culprit in this PIO event was the aircraft effective time lag. This is a composite of a variety of time lags due to filters, higher-frequency aircraft modes, actuator dynamics and digital system delays which, in sum contributed an incremental time delay of about 0.27 sec. It was even greater in the PIO because of the nonlinear time lags due to rate limiting effects.

4. F-8 Digital Fly-by-Wire Experiments – The "Definitive" Lag Data

In sporadic experimental work attempting to elicit quantitative understanding of those PIO phenomena associated with time delay, a fairly large data base has been gathered using simulators of all sorts, fixed and moving ground-based, and airborne using variable stability aircraft. As shown in Figure 20, pilot ratings for simulators and even for relatively benign airborne tasks are only moderately sensitive to effective time delay (Ref. 77). But, for crux moves with high attentional demands and focused purpose, the time delay can be of paramount importance. Indeed, "excessive" values can guarantee that a PIO will occur sometime, somewhere. Motivated at least partly by a desire to better understand the shuttle ALT-5 PIO, an experimental series was conducted with the NASA Dryden Digital Fly-by-Wire (DFBW) aircraft (Ref. 19).

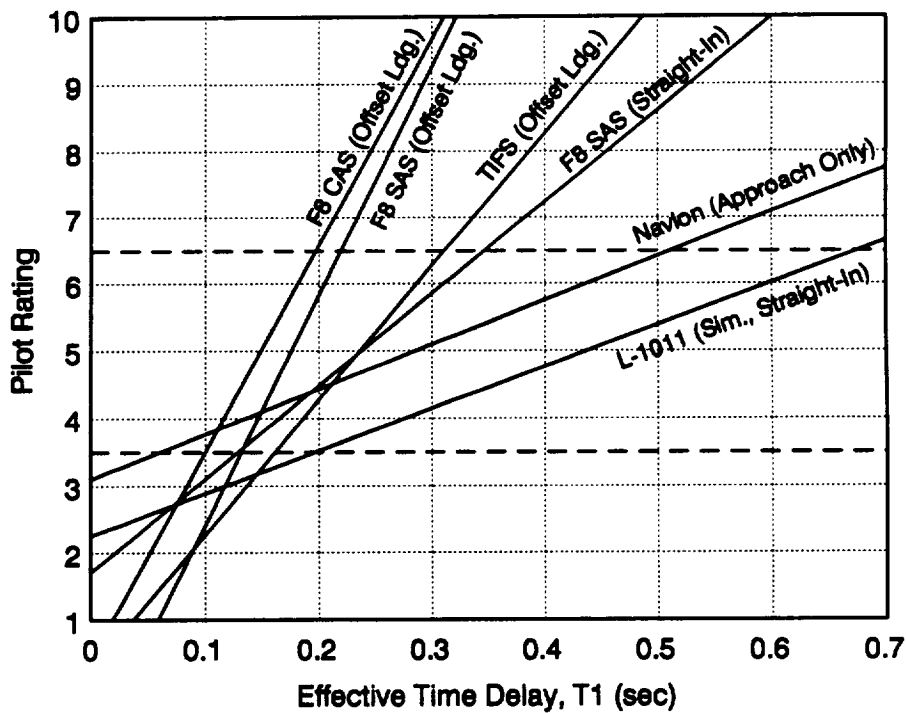

Figure 20. Effective Time Delay Data from Flight and Simulators (Ref. 77)

The aircraft was configured for experiments to investigate the effects of flight control system (FCS) time delays on flying qualities. Approach and touch and go landing tasks were used to emphasize a high degree of pilot involvement and intensity in the task. As shown by the flight recording (Figure 21) of a flight test sequence conducted on Apr. 18, 1978, the tests were a remarkable success.

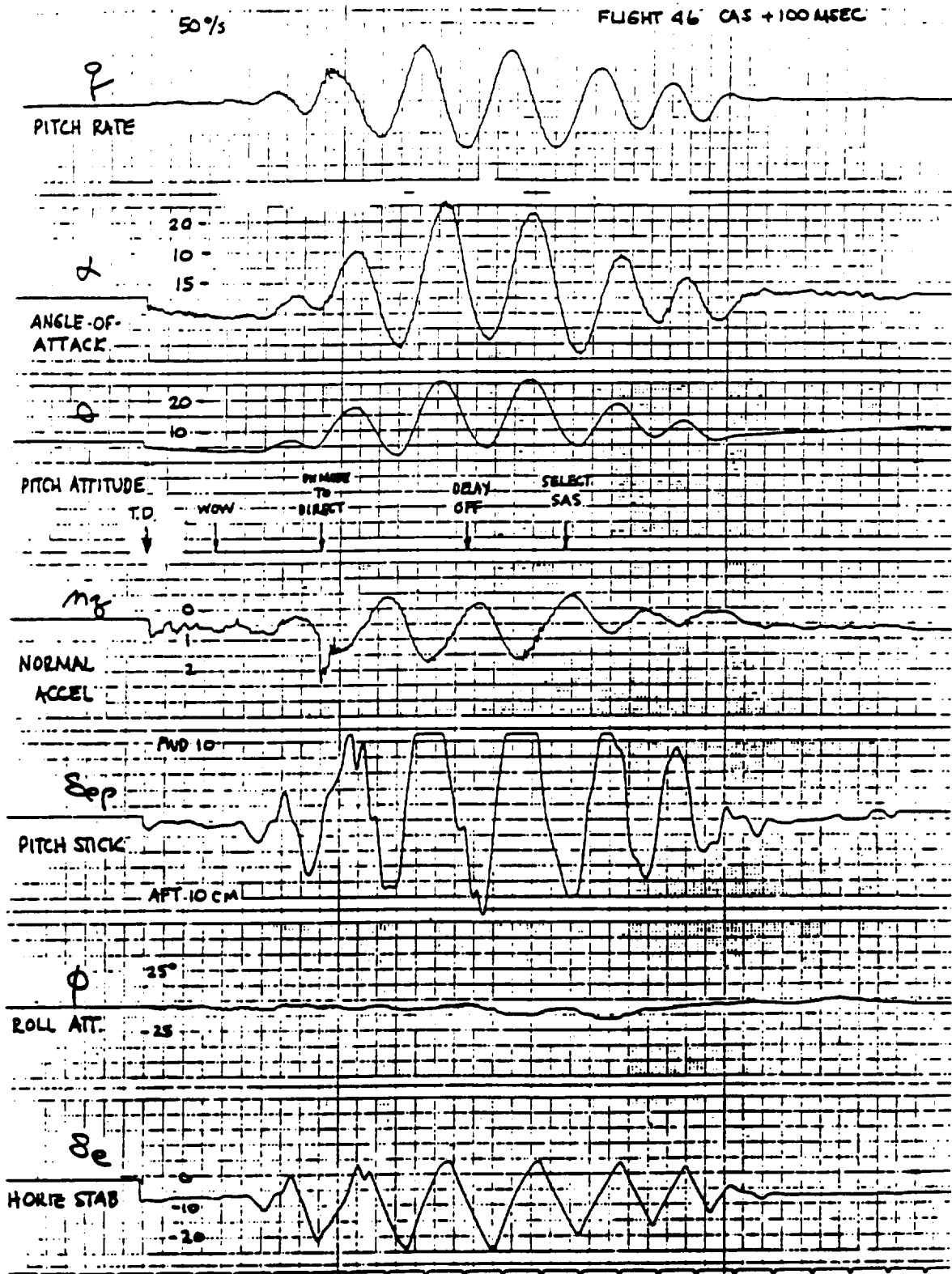

Figure 21. Flight Recording of F-8 DFBW PIO (NASA Ames/Dryden Flight Research Facility)

At touchdown the effective vehicle dynamics were automatically changed. The weight-on-wheels switch removed a normal acceleration feedback (including a forward loop integrator) and the stick force gradient also shifted to higher values. The experimental test point was at 200 knots which was too fast for nose wheel touchdown, so the pilot held the airplane nose high, so nose high, in fact, that the aircraft suffered a tail strike. At that point the SAS was automatically disengaged, so the effective aircraft dynamics were those of the airplane alone except for the 100 millisecond delay associated with the time lag experiment. The PIO then became well-developed. On the second oscillation the pilot punched out the delay and re-engaged the normal SAS, enabling a routine recovery.

Although it contained a number of unplanned elements this experiment was, in the event, ideally configured to definitively establish the impact of effective time delays on piloted control. Having demonstrated this point, the pilot declined to provide repeat runs! Thus the value of about 100 milliseconds as a maximum-allowable net incremental delay was born! This value of T_1 corresponds to the Level 1 boundary for the steepest of the Figure 20 regression lines.

B. MISMATCHED PILOT-AIRCRAFT INTERFACE CHARACTERISTICS

It has been well-known for many years that the pilot gain required to accomplish precision high-gain tracking-like tasks is a predominant factor underlying the pilot's assessment of the flying qualities of a particular aircraft configuration (e.g., Ref. 46). If the controlled element gain is varied in such full-attention, high-gain tasks, the crossover frequency of the open-loop pilot-aircraft system is maintained essentially constant by a countering self-adjustment of the pilot's gain. The "cost" of such an adjustment is reflected in the pilot rating. Figure 22, from Ref. 46, illustrates the general nature of this relationship for effective vehicle dynamics which approximate an ideal rate control form. Since the approximate transfer characteristic is $Y_c = K_c/s$, other vehicle-dynamics aspects are irrelevant.

Several general observations can be made about the trends of Figure 22. First, there is an optimum controlled element gain for each case. These optima are used as normalizing factors to coalesce the data from the several sources. Second, the optima lie in rather broad regions in which a change of plus or minus 50 percent in controlled element gain, K_c , incurs a penalty of no more than one rating point. This implies that, once the effective vehicle sensitivity is properly adjusted, minor controlled element changes are easily accommodated by the pilot, and are not major factors in pilot rating. Third, outside the broad optimum region, there are major decrements in pilot rating associated with either too-sluggish (K_c too small, pilot gain, K_p , too large) or too-sensitive (K_c too large, pilot gain, K_p , too small). Either extreme can be connected with a PIO tendency.

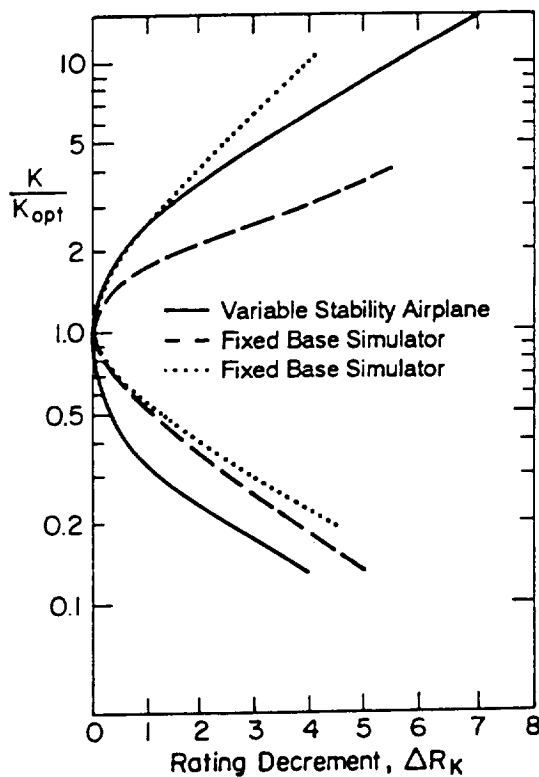

Figure 22. Pilot Ratings vs. Controlled Element Gain (Ref. 46)

The determination of the optimum controlled element gain is clearly a matter of supreme importance to assure a favorable pilot-aircraft interface, effective pilot-vehicle interactions, and an absence of PIO tendencies. With conventional center sticks, pedals, and yokes decades of past practice provide traditional answers. With the introduction of full-authority stability augmentation and fly-by-wire systems the stick "inceptor" has permitted the introduction of many other options. These range from side versus center cockpit locations, force-alone versus various degrees of motion, etc. Also, the inceptors have become "subsystems" by incorporating sensors and frequency and nonlinear amplitude shaping circuits. Further, the harmonization of within- and between-axis characteristics of cockpit inceptors which share functions, such as the conventional stick as a lateral and longitudinal controller, has new dimensions. Consequently, the proper setting of controlled element gain has become a nontrivial development aspect on every new aircraft which introduces a new inceptor at the pilot-control-system interface. In the absence of an extensive background of data for these there is no basis other than experiment to determine the optimum gains. The pathway to ultimate success has often had many byways, with minor wiggles, bobbles, and ratchets, as well as occasional severe PIOs.

The detailed issues which must be examined for a new inceptor are many and varied. Major questions with a side stick, for instance, include control sensitivity and PIO susceptibility in precision maneuvering, roll (or pitch) ratchet or jerkiness in otherwise steady maneuvers, sensitivity to pilot gripping techniques

and arm/hand support characteristics, effective time delay and amplitude and frequency shaping of stick filters, biodynamic interactions, minimum and total motions/forces, etc.

In the course of preparing for the flight of new aircraft, fixed- and, sometimes, moving- base simulations are used to determine initial gains, which are then refined in flight tests. Unfortunately, experience has shown that fixed-base, and even in-flight simulations, have not been generally reliable predictions of the best controlled element gains. Even with conventional inceptors, attempts to set appropriate sensitivities in fixed-base simulators are seldom fruitful. As noted in Ref. 78, "Pilots (particularly fighter pilots) always want a very responsive airplane; however, when real-world motion and visual cues are experienced their opinion frequently is revised..." Typically, the fixed-base simulator values are too large. For newer inceptors such as side sticks, the simulations are also usually inadequate to address all the major questions listed above. For instance, considering pitch axis control alone without any biodynamic considerations, amplitude nonlinearities found acceptable or even desirable in the simulations are often not appropriate in flight, sometimes becoming a factor in PIOs. Further, cross-axis harmonization demands a flight venue even to achieve, much less to validate, satisfactory results. Thus, in the modern era where a wide variety of novel controller inceptors and multiple aircraft control effectors are being considered, flight-based developments are an essential aspect of what previously was a detailed design feature. And, these may not always be simple and straightforward. The adjustments required have generally involved complex ad hoc empirical modifications which must be acceptable to a reasonable cross-section of pilots. For example, Ref. 79 summarizes some aspects of the F-16 side stick controller/roll prefilter development which included a 155 flight, 34 pilot program evaluating 19 different side stick and prefilter configurations in the YF and F-16A aircraft. Of the 155 flights, 74 were devoted to stick displacement, force gradient, and input axis orientation considerations, while 81 considered various roll pre-filter configurations.

The determination of optimum effective aircraft gains, pilot controller gain and frequency shapings, etc. are not the only features that are difficult to evolve reliably in ground-based simulators. Comprehensive simulation studies to gain understanding and detailed examinations of specific aircraft have, as yet, been insufficiently representative of the flight environment to be reliable quantitative predictors of PIO tendencies. Even variable stability aircraft results can be ambiguous because the relationships between acceleration at the pilot's station and attitude are configuration- and speed-specific. A proper match may require that the variable stability aircraft have high authority, high bandwidth force as well as moment producers. Only the USAF Total In-Flight Simulator (TIFS) aircraft is currently in this class for relatively low speeds, and there is nothing available for high speed flight. Some of the real world complications associated with the understanding and assessment of severe PIO potential are summarized in Figure 23.

**EXTRAORDINARY RANGE OF POSSIBLE VEHICLE/PILOT
KEY FACTORS**

PIO'S ARE VERY RARE EVENTS

Systematic, comprehensive recorded data even rarer

Difficult to duplicate exact circumstances

MANY PIO'S INVOLVE FLIGHT ACCELERATIONS

Correlation of flight acceleration with other aircraft
state variables is configuration specific

SIMULATION DIFFICULTIES

Fixed base seldom useful as a predictor (may be ok
after the fact for diagnoses and assessments of
corrective measures)

Details of the critical higher-frequency SAS and
actuation dynamics, and of the inceptor characteristics,
are often poorly simulated

Because of washout requirements, most moving base
simulators are nearly useless for prediction of PIO's
which have an acceleration component

Even variable stability aircraft simulators can be
poor predictors when accelerations are involved
unless changes in the acceleration/attitude
characteristics can be made

Figure 23. Real World Complications Associated with PIO Understanding and Assessments

The general inability to predict severe PIO tendencies in manned simulations is an encumbrance which deserves a great deal of attention to rectify. There is some hope. There is increased recognition that higher-frequency linear and nonlinear dynamics, appropriate inceptors, etc. are essential to an adequate simulation of the effective aircraft. Pilot-centered investigative techniques, such as the increased use of large amplitude, pilot-inserted deliberate abusive inputs in attempts to elicit PIO tendencies offer some potential. Display technology is continually improving to better approximate the visual scene. Experimental scenarios which enhance pilot urgency, gain, etc. are receiving more attention. Perhaps the best thing that can be said is that most famous PIOs, once they are discovered in flight, can often be duplicated to some extent. So, why not discovered earlier?

C. CONTROLLER RATE LIMITING

Almost all severe PIOs for which detailed time traces are available exhibit rate limiting of one form or another (see, e.g., Figures 19 and 21). In most examples the source of the rate limiting was in the surface actuation system. The major effect can be illustrated using the simplified model shown in Figure 24. In this elementary first order system the linear system effective time delay is simply $1/\omega_a$, which is also the time constant, and the inverse of the bandwidth. More pertinent to the analogy which will be drawn here, it is the system rise time — i.e., the time that would be taken to reach the final value at the maximum velocity developed in the step response. Although there are no unequivocal definitions of bandwidth or effective time delay for a nonlinear system, an equivalence based on rise time is appealed to here. On this basis, the effective time delay for the rate-limited system, τ_a , will be

$$\frac{1}{\omega_a} \leq \tau_a \leq \frac{\delta_{\max}}{V_L} \quad (16)$$

In this simplified view, the previous discussions of excessive lag as a major factor in severe PIOs acquire an added dimension. Qualitatively, the effect of rate limiting is to increase the effective time delay as a function of the pilot's amplitude. In general, this will reduce the neutral stability frequency and limit the amplitude of any sustained oscillation.

For more precise estimates of the impact of surface actuator rate limiting a more elaborate and accurate describing function is required. Sinusoidal-input describing functions appropriate for more realistic actuator system dynamics can readily be developed with the aid of computer simulations or of frequency response measurements on the actual hardware. A middle ground is also available using the sinusoidal-input describing function derived in the Appendix of Ref. 10. This describing function is used in Ref. 10 to study the effects of the rate-limited actuator as a participant in the famous PIO encountered on the X-15 airplane (Ref. 13). In that example the surface rate limit, which was only 15°/sec, played a major role in the PIO, in which the absence of an active pitch damper also was a factor.

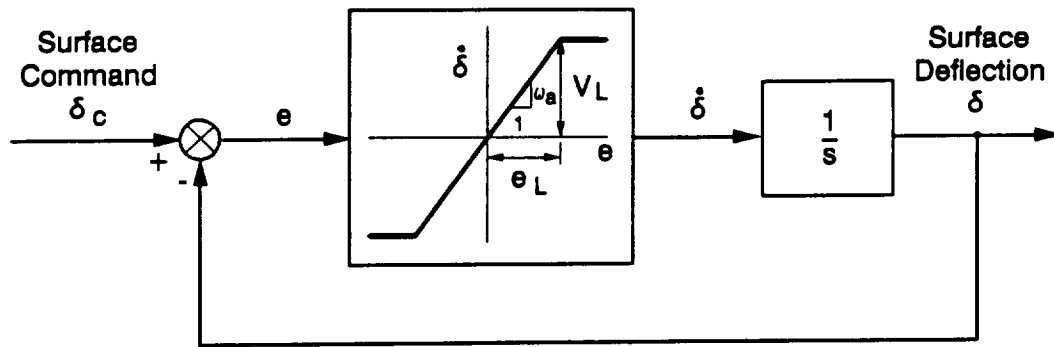

a) Block Diagram

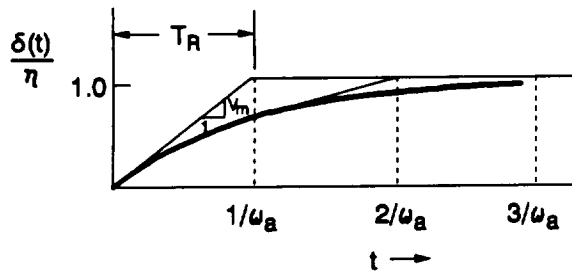

LINEAR RESPONSE, $\eta \leq \theta_L$

$$V_m = \eta \omega_a \leq V_L$$

$$1/\omega_a$$

$$\omega_a$$

$$1/\omega_a$$

Maximum Velocity

Rise Time,

Bandwidth

Effective Time Delay

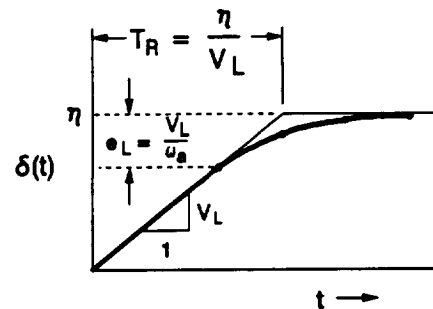
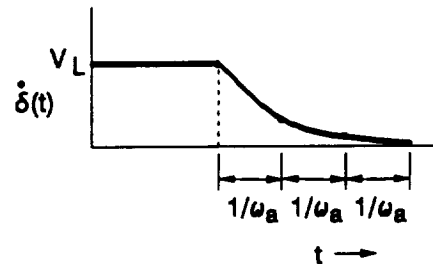

NONLINEAR RESPONSE, $\eta \geq \theta_L$

$$V_L$$

$$\eta/V_L$$

$$\left. \begin{array}{l} V_L/\eta \\ \eta/V_L \end{array} \right\} \text{Based on Equivalent Rise Time}$$

b) Responses to Step Inputs, $\delta_c = \eta u(t)$

Figure 24. Simplified Surface Servoactuator System

The subsequent fixes to the system included an increase of the control surface rate limit to 25°/sec and the imposition of a launch rule requiring that the pitch damper be operational.

D. VEHICLE DYNAMICS TRANSITIONS

The PIO scenarios which are most difficult to understand in their details are associated with transitions in the pilot behavior or in the vehicle dynamics. The former has been described at some length above, the latter will be illustrated by reference to two examples here. "Vehicle Dynamics Transitions" in general refer to changes in the effective vehicle dynamics which are induced by changes in the flight control system configuration, or by dynamic shifts accompanying the application of large pilot commands to the effective aircraft. The DFBW F-8 aircraft time traces of Figure 21 provide an example of vehicle dynamic transitions in which the flight control system configuration was changed. The weight-on-wheels switch removed the normal acceleration feedback and forward loop integrator and the tail strike disengaged the rest of the stability augmentation system. So, in a short period of time the effective vehicle dynamics presented to the pilot took on two different forms. Two examples of the other form of transitions, those associated with nonlinearities in the effective aircraft dynamics as they are affected by different amplitudes of pilot command, will be summarized below.

1. The YF-12 PIO

Ref. 15 describes a study to understand and determine the causes of some large amplitude PIOs encountered on the YF-12 airplane. Figure 25 is a time history of a $\pm 2g$ PIO triggered by a faulty trim switch which resulted in an overshoot in longitudinal trim as the airplane was approaching a tanker just before hookup. The pilot reacted to the trim overrun and took abrupt corrective action to keep the airplane from reaching its g limit, in the process entering the PIO.

The effective longitudinal dynamics of the YF-12 were made up of the elements incorporated in the block diagram of Figure 26a. The stability augments was a limited authority (2.5° trailing edge up, 6.5° trailing edge down) pitch damper, with a rate limit of 12.6°/sec. The SAS appears in a feedback loop, with the describing functions N_1 and N_2 representing the rate and position limits respectively. Describing functions for the effective aircraft were developed for a sinusoidal control input amplitude typical of those involved in the PIOs; these are shown in Figure 26b. Notice that, at the PIO frequency of approximately 0.5 Hz (3.14 rad/sec) denoted by the tick on the frequency scales for the amplitude and phase data, the position limit differences are minor, implying that the rate limiting is the major factor at this frequency. Notice also that the nonlinearities put the worst face on the stability issue — increasing the amplitude ratio while creating an additional phase lag. Ref. 15 demonstrates that the observed PIO frequency and amplitude is consistent with a synchronous pilot operating in conjunction with the effective vehicle dynamics defined by the describing functions. The study also demonstrated that a neutral stability

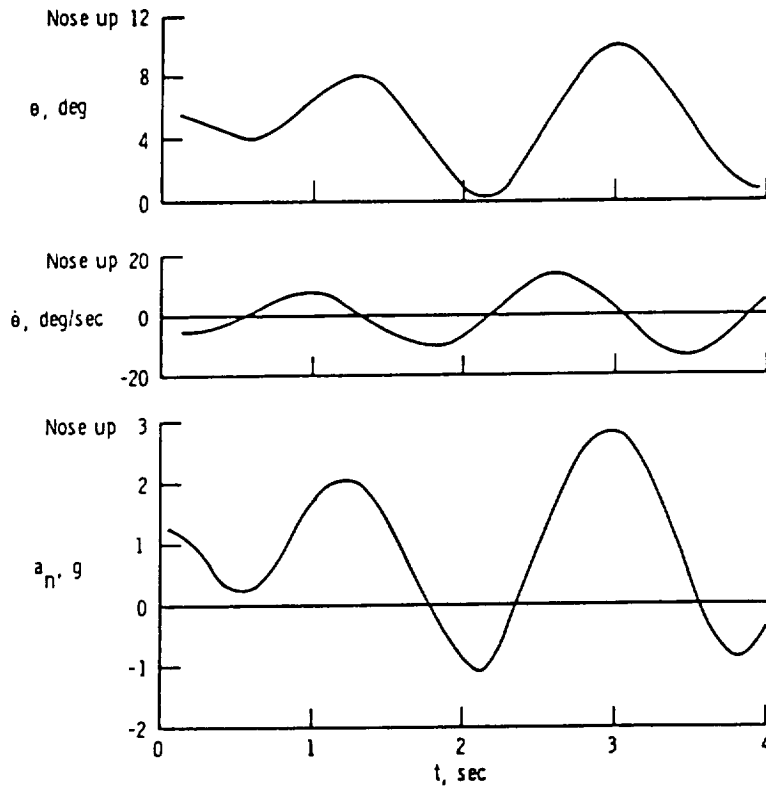

Figure 25. Large-Amplitude YF-12 PIO Time History (Ref. 15)

frequency obtained with the system in its linear range was far too high, so that the rate limiting nonlinearity was essential to duplicate the observed PIO.

Reduced to its simplest terms, the YF-12 PIO is a straightforward transition involving a change in the short-period damping ratio of the effective aircraft dynamics as a function of the pilot's input amplitude. The change in dynamics due to the nonlinearities is such as reduce the pilot gain needed to sustain a PIO by more than 50 percent.

2. T-38 PIO

One of the most interesting and instructive PIO examples in which transitions in the vehicle dynamics played a prominent role occurred on January 26, 1960 with an early version of the T-38 trainer. This was a landmark in PIO history because the aircraft was well instrumented and the PIO was extensively studied at the time (Refs. 10, 29, 30, 31) and since (Refs. 16, 32). The flight recorder time traces shown in Figure 27 indicate that the aircraft initially suffered from a low-amplitude high-frequency oscillation involving only the pitch axis airplane plus stability augmentation system (the pilot stick force is zero during this pre-PIO phase). The pilot disengaged the pitch augments and began an attempt to control

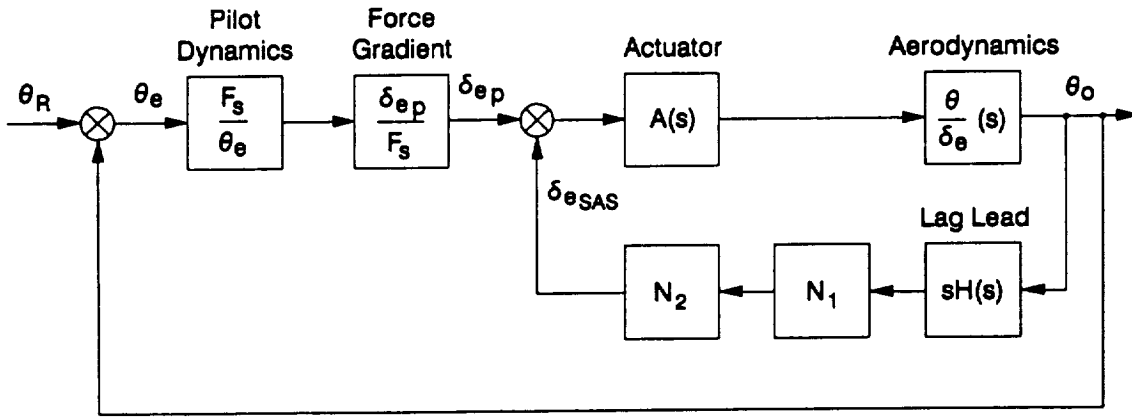

a) Block Diagram

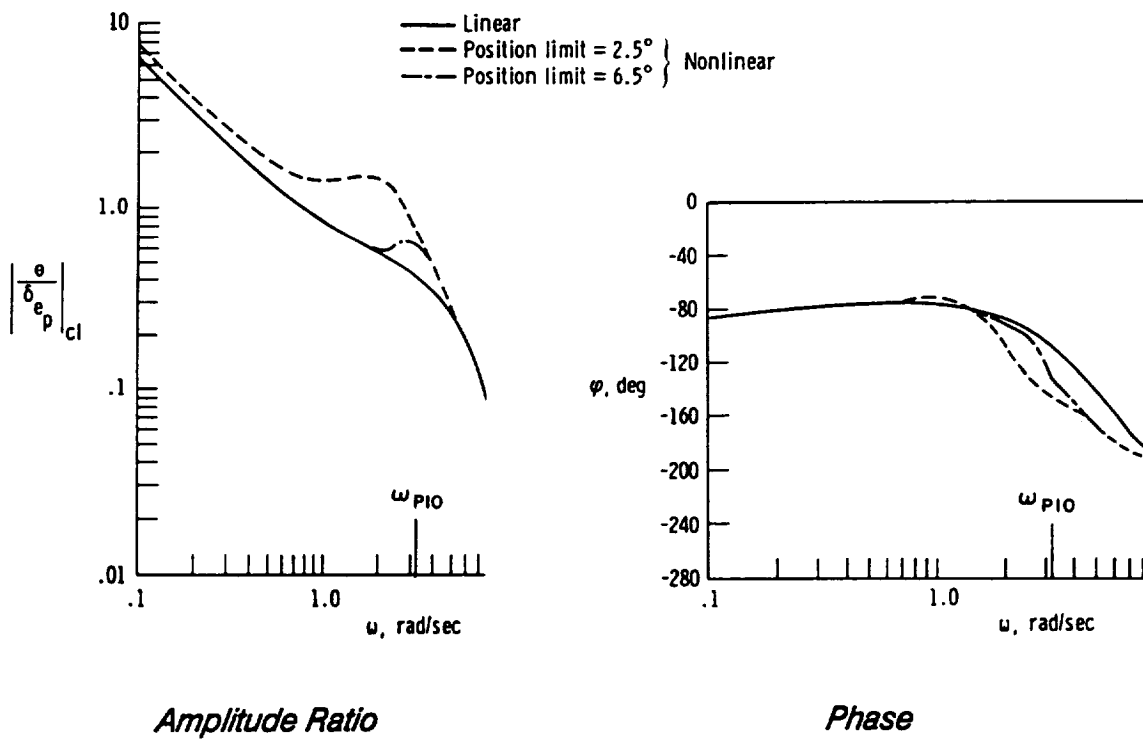

Figure 26. Bode Diagram of YF-12 Longitudinal Control System and θ/δ_{ep} Describing Functions (Adapted from Ref. 15)

the resulting upset. A 7.4 rad/sec PIO then developed very rapidly, and in just a cycle or so had achieved a peak-to-peak amplitude of 10g, increasing gradually to $\pm 8g$!

After a great deal of analysis and moving base simulations, this PIO was associated with transitions in both vehicle and pilot dynamics. The first transition is, of course, between the effective aircraft dynamics augments-on and augments-off. Even augments-off the aircraft presented two limiting cases of effective dynamics. The airplane's primary flight control system incorporated an artificial feel system and an effective bobweight intended to improve the stick force/g properties. The T-38 is a trainer, with linked tandem cockpit controls. There are several unbalanced masses distributed throughout the mechanical control system, including one small lumped bobweight. Consequently, the effective bobweight is the composite of all these sources which, incidentally, varies with the trim position of the interconnected control sticks. The bobweight effect not only changed the steady-state stick force/g, but also created a mechanical feedback loop within the control system. The actual aircraft dynamics presented to the pilot at a particular pilot amplitude depended on the distributed control system frictions, flexibilities, bobweight contributors, accelerations at the bobweight contributor locations, as well as the pilot stick force levels. So, illustrated in Figure 28 this created as limiting conditions, a bobweight-in, bobweight-out pair of effective aircraft dynamics. Figure 29 illustrates the pitch attitude to stick force describing function characteristics for the two limiting conditions. The bobweight-in condition represents a condition pertinent to large pilot amplitudes, while the bobweight-out condition is a limiting case as the amplitude approaches the system friction level seen by the pilot. There it is seen that the bobweight reduces the low-frequency gain of the airplane, just what it was installed to do. But the effect of the bobweight feedback in the short period frequency range is to increase the effective short period frequency and to reduce the damping ratio, causing the major resonant peak and the much steeper change in phase lag with frequency. This effect is so profound that the maximum pilot gains corresponding to neutral closed-loop system instability for the bobweight-in and bobweight-out effective vehicles differ by a factor of 4! Thus an enormous amount of highly nonlinear adaptation is required of the pilot when acting with the high gains appropriate to regain control after an upset.

To the extent that the pilot was involved at all initially, he was adapted to the SAS-on aircraft dynamics. Then, after disengaging the SAS, and beginning to take over control, the effective vehicle dynamics appear as the no-bobweight case, transitioning shortly thereafter to the bobweight-in dynamics. The high gain the pilot adopts initially to overcome the upset is far too large when the bobweight-in condition is reached, and the PIO develops. In the fully-developed PIO the pilot's transfer characteristics approximated a pure gain, indicating that a degree of synchronous precognitive behavior was present. The PIO was gradually reduced as the pilot lowered gain and regained control over the situation.

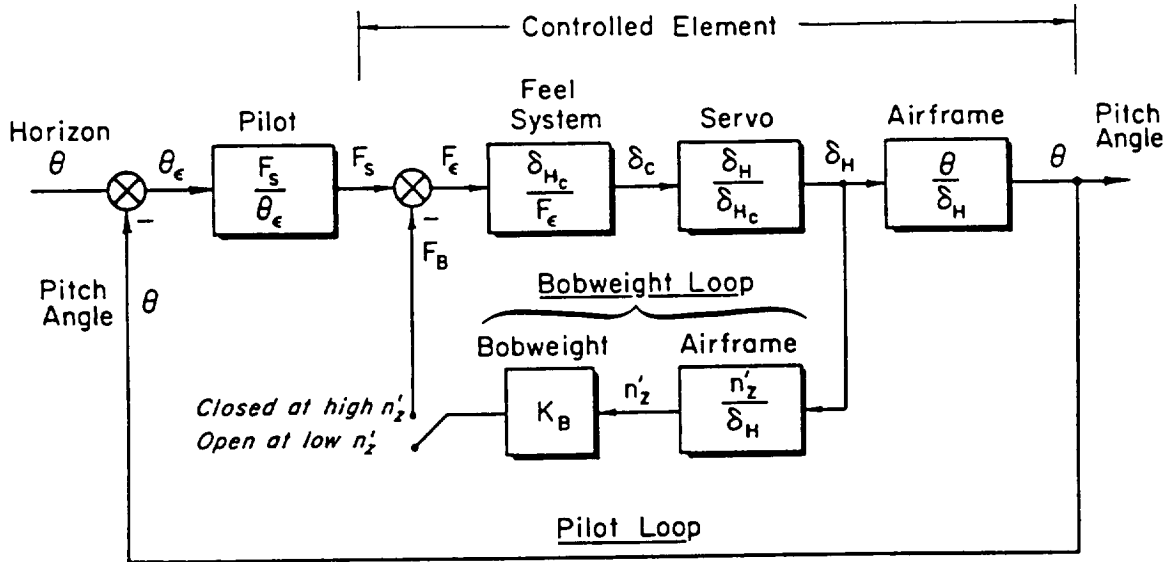

Figure 28. T-38 Primary Control System Block Diagram (Ref. 10)

That this scenario is a reasonable description of what happened is made credible not only by detailed analyses, but also by extensive simulations and flight testing with major control system (bobweight and artificial feel system) modifications which substantially reduced the differences between the two limiting sets of effective aircraft dynamics. Also, moving base simulator studies (Ref. 31) produced direct evidence that the pilot very likely did adopt synchronous behavior in the fully-developed PIO.

This example can also give some insight into "proper" recovery procedures. In principle, the pilot could either let go of the stick, or "clamp" the stick. In either event the airplane's motions would gradually damp out. But the effective damping ratio is quite different. For the first case, the effective airplane dynamics would be those with the bobweight in, corresponding to "stick-free" characteristic. For these the effective short-period damping ratio would be about 0.1. For the clamped condition ("stick-fixed") the damping ratio is about 0.4. So, for this type of system at least, the clamping procedure would be preferred.

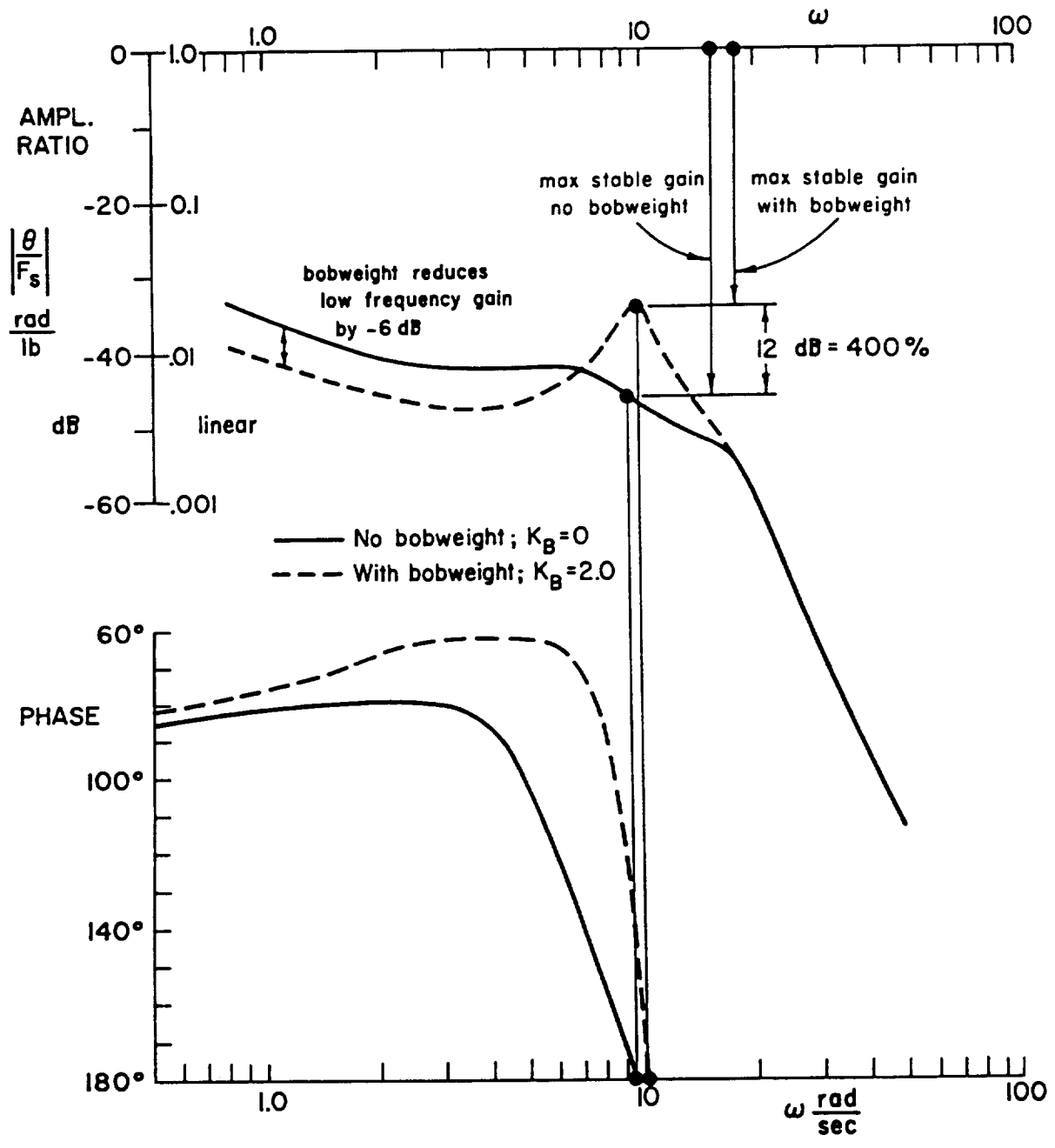

Figure 29. Effect of Bobweight on Pitch Response (Ref. 10)

SECTION V

TRIGGERS AS CENTRAL FEATURES IN SEVERE PIOs

An awkward attribute which is a central and complicating feature of severe PIOs is an initiating event, upset, or trigger which starts the sequence. The awkwardness stems from their great diversity, making generalization difficult or impossible. A few typical examples for PIOs cited in Table 1 are:

T-38 — Failed stability augments; disconnect sequence created a major upset (see Ref. 10);

B-58 — Failed stability augments, creating sideslip and subsequent rolling and, simultaneously, unfavorable ω_ϕ/ω_d roll-control dynamics;

YF-12 — Faulty trim switch, trim overshoot (see Refs. 15, 16);

YF-16 — Several undesired inputs coupled with limiting effects (see Ref. 11);

Shuttle — ALT-5, 30 mph over-speed on very first runway approach; speed brake actuated, nosed down to make desired impact point; pilot plus transient upset basic approach;

DFBW F-8 — Major unexpected change in effective controlled element dynamics;

YF-22 — Afterburner start, pilot input, plus mode transition circuitry interacted to create a major upset;

MD-11 — Inadvertent slat deployment (see Ref. 21).

Another interesting example of an unforeseen trigger mechanism is cited in Ref. 80. This occurred during spin-recovery testing where a pitch PIO followed the recovery, increasing in magnitude, then subsiding. The explanation, verified by ground-based simulation, was that there was a lag term built into the pitch feel dynamic pressure scheduling which, when combined with the rapidly changing flight condition, allowed inadvertent high pilot gain in pitch control for a period during the recovery.

As emphasized in the previous discussion of pilot behavioral modes, triggering upsets can also arise from shifts in the pilot's organization of behavior. These include changes in the pilot's goals, attention, and neuromuscular tension which reflect into higher pilot gains, controller offsets, or control reversals. A major source of upsets is the surrounding external and internal environment. The latter category includes gusts, wind shears, etc. as well as control system shifts acting on the airplane. It also includes changes which enter the pilot-vehicle system via the pilot, such as drastic evasive maneuvers.

Great efforts are taken in modern multiple redundant fly-by-wire aircraft to seamlessly transition from one set of aircraft characteristics to another. Unfortunately, with even the most modern and elaborate systems (e.g., YF-22) some upsetting condition within the FCS itself or pilot behavior transitions within the pilot-vehicle system seem to creep through. The lure of software "solutions" to all sorts of imagined

problems become easier to espouse; but unimagined events can remain submerged only to surface in an untimely way. Unfortunately, a "catalog" of such possibilities (see, e.g., Figure 30) at present exists only in a rudimentary beginning state!

TASK CHANGES WHICH INDUCE CHANGES IN PILOT BEHAVIOR

e.g., from Attitude to Load Factor Control

APPROACHING LIMITS (STALL, G-LIMIT, GROUND PROXIMITY, FLIGHT PATH CONSTRAINTS, ETC.)

FLIGHT CONTROL SYSTEM SHIFTS

Stick-Fixed to Stick-Free Dynamics

Rate/Position Limiting

Transitions Between Task-Tailored FCS Modes

SHIFT IN AIRCRAFT DYNAMICS

Sudden Gain Changes

Rapid Onset of Significant Aircraft Nonlinearities

Saturation of a Limited Authority SAS

UNEXPECTED AIRCRAFT DISTURBANCES

Clear Air Turbulence

Jet Upsets

Vortex Encounters

Microbursts

Figure 30. Precursors/Triggers Mechanisms/Pilot Mode Shifters

SECTION VI

SUGGESTED PILOT-BEHAVIOR-THEORY-BASED CATEGORIES FOR PIO

Because of the diverse considerations entering into oscillatory aircraft-pilot couplings several kinds of classification schemes could be proposed to group PIOs with similar aspects. In the "Historical Perspective" section some "Famous PIOs" were classified by primary control axis and the frequency of the PIO. The detailed analytical studies, e.g., Refs. 10, 11, 15, 16, 18, 26, etc., of some of the "Famous PIOs," as well as previous sections of this report, relied on pilot behavioral models and closed-loop analysis procedures to elicit understanding and rationalization of the phenomena and their associations. Then, in some cases, pilot-vehicle behavioral models were used as a basis for designing and assessing changes to the effective vehicle to alleviate the PIO potential.

The pilot models and analysis procedures used in attempts to understand, "explain," and predict, were not specific to any one of the Table 1 groups; instead, they had some application across the groups. The categories in the classification scheme suggested here follow from the successes of this past experience. The world of potentially severe PIOs is divided into three categories based on utilization of existing pilot behavior models and analysis techniques. The categories proposed are described below.

A. PROPOSED CATEGORIES

Category I — Essentially Linear Pilot-Vehicle System Oscillations: The effective controlled element characteristics are essentially linear, and the pilot behavior is also quasi-linear and time-stationary. The oscillations are associated with high open-loop system gain. The pilot dynamic behavior mode may be pursuit, compensatory, precognitive, or synchronous.

In this category no significant frequency-variant nonlinearities (see, e.g., Ref. 81) are involved in the controlled element dynamics (hence there is just one effective Y_c/K_c) and no behavioral mode shifts occur in the pilot (so Y_p/K_p is fixed). There may be changes in either the pilot or the controlled element gain, so such things as nonlinear stick sensitivity or pilot attention shifts may be admissible as features consistent with Category I. The pilot-vehicle oscillations in this category may be casual, easily repeatable, readily eliminated by loosening control (lowering pilot gain), and generally non-threatening. On the other hand, with a major triggering input the oscillations may be quite severe especially when gain-dependent simple nonlinearities are involved.

As illustrated in the examination of the Bjorkman sustained PIOs for a given pilot cue structure, analyses of Category I oscillation possibilities can reveal the oscillatory frequencies consistent with a presumed type of pilot behavior (e.g., compensatory or synchronous), pilot gain levels, nominal high-gain pilot-vehicle system bandwidths, various sensitivities to effective vehicle characteristics, etc.

Category II — Quasi-Linear Pilot-Vehicle System Oscillations with Surface Rate or Position Limiting: These are severe PIOs, with oscillation amplitudes well into the range where actuator rate and/or position limiting in series with the pilot are present as primary nonlinearities. The rate-limited actuator modifies the Category I situation by adding an amplitude-dependent lag and by setting the limit cycle magnitude. Other simple nonlinearities (e.g., stick command shaping, some aerodynamic characteristics) may also be present. These are the most common true limit-cycle severe PIOs.

Category II PIOs are very similar to those of Category I except for the dominance of key series nonlinearities. They are invariably severe PIOs, whereas Category I covers both low and large amplitude levels.

The oscillatory conditions remain those of Eq. 1, although it is usually modified to the form,

$$Y_p Y_c = -1/N \quad (17)$$

where the left hand side represents the linear parts of the open-loop pilot-vehicle dynamics and the right hand side is a composite describing function of the series nonlinearities. The describing function N typically depends on the nature of the nonlinearity and the input amplitude. Many examples of "N" may be found in Ref. 81, and a rate-limited actuator describing function plus a typical illustrative analysis is given in Ref. 10 for the X-15 PIO.

Category III — Essentially Non-Linear Pilot-Vehicle System Oscillations with Transitions: These PIOs fundamentally depend on nonlinear transitions in either the effective controlled element dynamics, or in the pilot's behavioral dynamics. The shifts in controlled element dynamics may be associated with the size of the pilot's output, or may be due to internal changes in either control system or aerodynamic/propulsion configurations, mode changes, etc. Pilot transitions may be shifts in dynamic behavioral properties (e.g., from compensatory to synchronous), from modifications in cues (e.g., from attitude to load factor), or from behavioral adjustments to accommodate task modifications.

The Category III PIOs can be much more complicated to analyze than the other two in that they intrinsically involve transitions in either the pilot or the effective controlled element dynamics. Thus there are a minimum of two sets of effective pilot-vehicle characteristics involved: pre- and post-transition. When these differ greatly, as in the T-38, YF-12, and YF-22 circumstances, very severe PIOs can occur.

B. COMMENTARY

The categories suggested above do not differentiate as to PIO severity — large-amplitude severe PIOs can occur in all categories. They also have little if anything to say about the emotional aspects of a severe PIO. The pilot involved cares not at all whether his encounter was a Category I, II, or III! For the analyst, on the other hand, such details are essential to permit the use of available tools and analysis techniques with which to develop understanding of the event and determine corrective action.

Much of the flying qualities and PIO generic data base that can be associated with the reduction of PIO potential associated with extended rigid-body effective aircraft modes has dealt with the situations covered by Category I. Consequently, the occasional presence of mild PIO tendencies in tight tracking tasks can be minimized by simply providing "good" flying qualities as can be defined by appropriate selection of the entries available in MIL-STD-1797A, for instance, those concrete provisions of MIL-F-8785C related to high-gain tracking tasks. (The MIL-STD itself is fundamentally a format, with actual phrases and quantitative values to be selected for specific cases from the associated MIL-STD-1797A Handbook and Users Guide by the specifying authority.) In this sense, appropriate criteria to avoid Category I PIOs are generally tantamount to those for Level 1 flying qualities, with emphasis on those criteria of most importance in high-gain closed-loop piloting tasks.

Unfortunately, several modern aircraft (e.g., YF-22, C-17, and JAS-39) with advanced fly-by-wire control FBW) systems have exhibited PIOs. The juxtaposition of PIO presence with new FBW systems has raised the visibility in much the same way as the ALT-5 shuttle earlier gained high-level attention. Thus, although they probably do not meet the kinds of requirements alluded to above, some recommended refinements to MIL-STD-1797A which specifically emphasize the possibility of PIO have recently been put forth (Refs. 2, 3). As would be expected, these are connected with excessive lag within the context of desirable pilot-vehicle system crossover characteristics. The initial steps taken propose to incorporate into the MIL-STD the "Smith-Geddes" PIO criteria based on Refs. 5, 6, and 16, as well as the "average phase rate," of Eq. 11 as suggested in Refs. 7 and 82. A version of the latter already appears in the handling qualities specification for the European Fighter Aircraft (Ref. 1). Other criteria, involving the "aircraft attitude bandwidth," $\omega_{BW\theta}$, and phase-delay measures of Eq. 10, have been recommended in Ref. 8. When reduced to attitude control considerations, all of these are attempts to specify frequency domain characteristics over which the pilot can exert precise, high-gain, control — e.g., well-behaved effective aircraft amplitude ratio characteristics (approximating K/s) in which lags are not excessive. In very many cases, the differences which exist in applications of these criteria are minor. When control of other variables, such as load factor, is an issue, Refs. 5, 6 consider pilot transition from attitude to load factor cues (a particular pilot-transition case of category III). Those Category I PIOs which are associated with higher-frequency non-rigid-body modes are not covered by the proposed criteria.

Until recently, major PIO issues on a new airplane have usually been confined to factors which can be treated in Categories I and II. This may well be changing. The full application of active control technology in flight control systems for modern high performance aircraft invariably results in multiple-redundant, multi-mode, task-tailored, fly-by-wire (or light) systems. These are technological marvels! Great efforts are taken in design to put limits in the right places, to seamlessly transition from one set of effective aircraft characteristics to another, to foresee all possible contingencies. Unfortunately, with even the most modern and elaborate systems (e.g., YF-22) some upsetting condition within the FCS itself or

pilot behavior transitions within the pilot-vehicle system seem to creep through. In this event, a Category III PIO is a likely consequence when appropriate triggers also arise. Avoidance of Category III PIOs is one of the great challenges of active control technology applications.

Past history indicates that the Category III PIOs are highly unusual but also very severe events. The post-transition effective vehicle dynamics are almost always unforeseen, as are the triggering possibilities. This type of PIO is particularly insidious because, in the best modern fly-by-wire designs the pre-transition (normal) effective aircraft dynamics are designed to have excellent flying qualities. Most of the system nonlinearities (e.g., limiters, faders, mode-switches, etc.) are deliberately introduced to counter anticipated problems. In all these systems the lure of software "solutions" to all sorts of imagined problems has become easy to espouse; but unimagined events can remain submerged only to surface in an untimely way. Indeed, it is only when the known-problem fixes act in peculiar, unanticipated, ways in the presence of large pilot inputs that the "bad" post-transition vehicle dynamics are created. Yet modern systems are so complex and elaborate that more rather than fewer Category III PIOs are likely to occur in the future unless matters change.

SECTION VII

INTERIM PRESCRIPTIONS TO AVOID PIO

It should be apparent from the above discussions that, while the general nature of the aircraft's oscillatory behavior can readily be appreciated from the visual evidence and sometimes supplemented by detailed quantitative data, the underlying pilot and aircraft responses which combine to create such devastating results are remarkably diverse and may be very difficult to "understand." Nonetheless, essentially all of the possible pilot and aircraft dynamic "contributors" listed in Figures 10 and 11 can be indicted, if not yet convicted as guilty! Consequently we must guard against them all for now, and carefully assess their possible joint actions for future aircraft. Some guiding formulae, such as those listed in Figure 31, may provide useful warnings, but a single definitive criterion is unlikely to cover all cases.

The first three "Attitude Control Features Inimical to PIO" listed in Figure 31 are related. The first and second prescriptions are two different ways to define "good" effective aircraft rigid-body dynamics for compensatory systems — implying that no lead equalization need be provided by the pilot, and that the net pilot-vehicle system high frequency lags be small. Taken together, these would assure that a maximum available crossover frequency in a compensatory system of about 5 rad/sec would still be stable. [For no pilot lead (pilot time delay about 0.2 sec) and an ideal K/s-like effective vehicle with 0.1 sec effective delay, the total system time delay is about 0.3 sec. The neutrally stable closed-loop frequency is then $1.57/0.3 = 5.24$ rad/sec.] The criteria of Refs. 1, 7, 8 and Refs. 5, 6 can provide useful insights and assessments.

The third attitude control feature guards against a fully-developed PIO in which the pilot develops synchronous behavior. It should be applied well into the flexible mode frequency range. Actual PIOs as high as 8 rad/sec have been encountered in which this type of behavior is implicated.

The "PIO Syndrome," defined by a long flat stretch on the θ/δ_e Bode diagram between the pitch attitude lead at $1/T_{\theta_2}$ and the effective short-period frequency ω_{sp} , can (hypothetically) raise difficulties in high workload situations. The crossover model properties for the pilot-vehicle system will nominally be established by pilot-generation of a low-frequency lag to cancel the attitude lead. In the event of a major upset demanding a high urgency response, the pilot may drop the smooth, trim-like low-frequency lag and transition to a proportional high gain control action, with PIO as a result.

The "Attitude Control and Load-Factor Control" prescription assumes as a starter that the pilot-vehicle system in attitude control has a gain sufficient to exhibit highly resonant closed-loop properties. Then, as developed in detail in Ref. 16, the pilot may switch primary control to normal acceleration (at the pilot's location). The prescription given in Figure 31 follows from this point.

ATTITUDE CONTROL FEATURES INIMICAL TO PIO

Ability to control θ/δ_F with $Y_p = K_p e^{-0.2s}$ over a very "wide" range of pilot gains

Airplane high frequency dynamic characteristics which exhibit less than 0.1 second effective time delay

Extremely wide range of stable pilot-aircraft system closures with the "synchronous" pilot model, $Y_p \doteq K_p$

Absence of a "PIO syndrome" (very long "shelf" between $1/T_{\theta_2}$ and ω_{sp}) in the pitch attitude transfer function

ATTITUDE CONTROL AND LOAD-FACTOR CONTROL

Ability to exert stable control of load factor with $Y_p = K_p e^{-0.25s}$ at the resonant frequency of the closed-loop pilot-attitude control system

LIMITING CONTROL AND LOAD-FACTOR CONTROL

"Be not stingy with rate limits!"

Seamless mode-switching and control-law shifts

Special pilot training for non-seamless transition situations

Figure 31. Interim Prescriptions for Reduction of PIO Potential

The third set of prescriptions are reminders. The need to avoid limiting, especially in control surface rates, follows directly from almost all the PIO examples cited. Although rate limiting is only very occasionally the dominant culprit, it is almost invariably present and contributing. The primary effect is to increase the effective time delay as a function of the surface actuator input amplitude. Indeed, for a given rate limit it is a fairly simple matter to estimate the pilot's output amplitude which can lead to an oscillation of the pilot-vehicle system. Clearly, margins in this regard should be high; miserly "savings" are likely to be regretted.

The last recipes listed in Figure 31 are becoming more difficult to achieve as software "solutions" to all sorts of imagined problems become easier to accomplish. Switching loops in and out, changing effective system gains, etc. can be justified on several grounds — but the spectre of PIO should be added to the assessment list before design decisions are made. The external environment and task demands present a number of PIO precursors/triggers which are beyond the designer's control; a number already quite sufficient without introducing additional ones as part of the design process!

SECTION VIII

CONCLUDING REMARKS

The dramatic events recounted here, and other less-well publicized PIOs, have received a great deal of attention from the community comprising test pilots and flying qualities, stability and control, and flight control engineers. The attention has, unfortunately, tended to be quite spasmodic, and is usually connected with specific PIO episodes. PIOs are rare, idiosyncratic, and the epitome of highly interdisciplinary interactions, and the search to understand them demands a combination of unusual technical talents. They are also a very great embarrassment, to the point that even the mere suggestion that a PIO tendency might be present can make an engineer extremely unpopular. Also, unlike many pre-flight engineering predictions, the best estimates of PIO potential are often the result of analysis rather than elaborate testing. Matters are made more complicated because manned simulation does not provide an unequivocal answer even when specially guided by analysis. So technical managers often retreat behind a veil that meeting specification requirements provides security against PIO. Such attitudes are short-sighted and, in the state of our present knowledge, unrealistic. Experience has shown that almost all high performance aircraft are likely to have PIO episodes sometime in their development or early operational experience, leading to yet another *ad hoc* "solution" at a great price. To put this evil genie back in the bottle will require an effective broadly-based program of analytical, experimental and flight research that has proved to be difficult to mount and to sustain.

The thrust of this report has been to summarize what is known about the key interactions which underlie pilot-in-the-loop oscillations. These are major players in a systems engineering treatment to achieve favorable human-machine integration and interfaces. The emphasis has been placed on the diversity and understanding of PIO phenomena; means to avoid PIO and criteria to assess PIO potential have been considered primarily as extensions of the understanding achieved or logic presented. Carried to an extreme, the simplest way to minimize PIO potential is to remove or counter as many of the identified causes as possible. But the story is not yet complete in that some of the candidates in Figures 10 and 11 are still highly qualitative, and their possible interactions to cause PIO are sometimes obscure. So, while much is known and understood for specific examples, an extended and comprehensive appreciation of PIOs continues to be a major challenge in flying qualities research. The challenge must be met if PIOs are to reliably be estimated and alleviated and the human pilot is to interact more safely with highly automated advanced aircraft. This is of no small importance, for such phenomena permeate aviation's history and remain with us today.

To complete the systems engineering toolbox needed to design favorable pilot-aircraft systems and to avoid unfavorable pilot-in-the-loop oscillations several issues should be addressed. They include:

- Applications of Existing Knowledge

- Continued efforts to understand the more complex severe PIOs which have occurred recently (e.g. C-17, YF-22, JAS-39, MD-11, and others).
- Immediate assessment of new advanced aircraft using all the proposed assessment criteria (e.g. Refs. 1, 3, 5, 6, 7, 8). As no existing aircraft have to meet these criteria contractually, these assessments should be undertaken as a safety of flight consideration to guide flight testing, operations, and training.
- Further development, modifications or elaborations in existing assessment criteria as needed to cope with (include) new Category I PIO data and experience.

- Simulation Procedures for Estimation

- Continued development of procedures for fixed-base, moving-base, and in-flight simulations to assess and predict PIO potential with a well-defined degree of confidence. Verisimilitude requirements for FCS equipment and inceptors, aggressive/aircraft-abusive piloting procedures, protocols to induce urgency, triggering possibilities, etc. should be considered. Attempts to duplicate existing in-flight PIO data should be used to verify conclusions and progress.
- Evolution of a variety of simulation-based pilot training protocols and programs to improve pilot situation-identification and responses in operational scenarios.

- Improved Understanding of Category II and III PIO Situations

- Development of interim assessment and predictive criteria and analysis procedures for Category II and III PIO potential.
- Ad hoc examinations of existing and proposed designs of advanced multi-mode, fly-by-wire, active flight control systems in a search for system states, transition conditions, and possible triggers which could be candidates for Category II or III PIOs.
- Formulation and execution of ad hoc experiments as follow-ons to the above ad hoc examinations.
- Refinement of the interim criteria and procedures in the context of the ad hoc examinations and experiments.
- Preparation of an advanced catalog of possible Category II and III PIO situations (based on projected as well as existing and proposed FCS modes and mechanizations) to serve as a foundation for simulation and flight experiments. For this to have maximum validity initial versions of the catalog should be extended by, and critically examined by, appropriate cross-sections of the aircraft stability and control and flight control community.

- Formulation and execution of appropriate experimental programs, using fixed-base through in-flight simulations, to explore the character and degree of pilot very-short-term adaptability available to contain Category II and III PIO situations.
- Further refinement of the interim assessment criteria to properly account for the improved understanding provided by the empirical programs.

REFERENCES

1. Buchacker, E., H. Galleithner, R. Kohler, and M. Marchand, "Development of MIL-8785C Into a Handling Qualities Specification for a New European Fighter Aircraft," in *Flying Qualities*, AGARD CP-508, Quebec City, Canada, 15-18 Oct. 1990.
2. Davenport, Otha, *Aircraft Digital Flight Control Technical Review Final Briefing*, AFMC/EN, 26 Oct. 1992.
3. *Draft MIL-STD-1797A Update*, ASC/ENFT, Flight Technology Branch, Flight Systems Engineering Division, Wright-Patterson Air Force Base, Ohio, 4 Nov. 1993.
4. Moorhouse, David J., "Experience with the R. Smith PIO Criterion on the F-15 STOL and Maneuver Technology Demonstrator," AIAA-94-3671-CP, *Proceedings of the AIAA Guidance and Control Conference*, Scottsdale, AZ, 1-3 Aug. 1994.
5. Smith, Ralph H., and Norman D. Geddes, *Handling Quality Requirements for Advanced Aircraft Design Criteria for Fighter Airplanes*, AFFDL-TR-78-154, Aug. 1979.
6. Smith, R. H., "The Smith-Geddes Criteria," presented at the SAE Aerospace Control and Guidance Systems Committee meeting, Reno NV, 11 Mar. 1993.
7. Gibson, J.C., "The Prevention of PIO by Design," in *Active Control Technology: Applications and Lessons Learned*, AGARD, Turin, Italy, 9-12 May 1994.
8. Mitchell, David G., Roger H. Hoh, Bimal L. Aponso, and David H. Klyde, "The Measurement and Prediction of Pilot-in-the-Loop Oscillations," AIAA-94-3670, *Proceedings of the AIAA Guidance and Control Conference*, Scottsdale, AZ, 1-3 Aug. 1994.
9. A'Harrah, Ralph C., "An Alternate Control Scheme for Alleviating Aircraft-Pilot Coupling," *Proceedings of the AIAA Guidance and Control Conference*, Scottsdale, AZ, 1-3 Aug. 1994.
10. Ashkenas I.L., H.R. Jex, and D.T. McRuer, *Pilot-Induced Oscillations: Their Causes and Analysis*, Northrop-Norair Rept., NOR 64-143, June 1964.
11. Smith, John W., *Analysis of a Lateral Pilot-Induced Oscillation Experienced on the First Flight of the YF-16 Aircraft*, NASA TM 72867, Sept. 1979.
12. Percy, Arthur, "Flying the Frontiers — NACA and NASA Experimental Aircraft," *Naval Institute Press*, Annapolis, Maryland, 1993.
13. Finch, Thomas W., and Gene J. Matranga, *Launch, Low-Speed, and Landing Characteristics Determined from the First Flight of the North American X-15 Research Airplane*, NASA TM X-195, Sept. 1959.
14. Matranga, Gene J., *Analysis of X-15 Landing Approach and Flare Characteristics Determined from the First 30 Flights*, NASA TN D-1057, July 1961.
15. Smith, John W., and Donald T. Berry, *Analysis of Longitudinal Pilot-Induced Oscillation Tendencies of YF-12 Aircraft*, NASA TN D-7900, Feb. 1975.
16. Smith, R.H. *A Theory for Longitudinal Short-Period Pilot-Induced Oscillations*, AFFDL-TR-77-57, June 1977.

REFERENCES (continued)

17. Powers, Bruce G., "An Adaptive Stick-Gain to Reduce Pilot-Induced Oscillation Tendencies," *J. Guidance, Control, and Dynamics*, Vol. 5, Mar.-Apr. 1982, pp. 138-142.
18. Ashkenas, I.L., R.H. Hoh, and G.L. Teper, "Analysis of Shuttle Orbiter Approach and Landing," *J. Guidance, Control, and Dynamics*, Vol. 6, No. 6, Nov.-Dec. 1983, pp. 448-455.
19. Berry, Donald T., Bruce G. Powers, Kenneth J. Szalai, and R.J. Wilson, "In-Flight Evaluation of Control System Pure Time Delays," *Journal of Aircraft*, Vol 19, No 4, Apr. 1982, pp 318-323.
20. Dornheim, Michael A., "Report Pinpoints Factors Leading to YF-22 Crash," *Aviation Week and Space Technology*, 9 Nov. 1992, pp. 53-54.
21. *Aircraft Accident Report PB 93-910408*, National Transportation Safety Board, NTSB/AAR-93/07; Washington, DC, 27 Oct. 1993.
22. Crawford C. Charles, and Jones P. Seigler, *KC-135A Stability and Control Test*, Air Force Flight Test Center TR 58-13, May 1958.
23. Simmons, Carl D., and Donald M. Sorlie, *F-101B Air Force Stability and Control Evaluation*, Air Force Flight Test Center, TR 58-11, May 1958.
24. Taylor, Lawrence W., Jr., *Analysis of a Pilot-Airplane Lateral Instability Experienced with the X-15 Airplane*, NASA TN D-1059, Nov. 1961.
25. Kempel, Robert W., *Analysis of a Coupled Roll-Spiral Mode. Pilot-Induced Oscillation Experienced with the M2-F2 Lifting Body*, NASA TN D-6496, Sept. 1971.
26. Smith, Ralph H., *Notes on Lateral-Directional Pilot-Induced Oscillations*, AFWAL TR-81-3090, Mar. 1982.
27. Abzug, M.J. and H.B. Dietrick, *Interim Report on Elimination of Pilot-Induced Oscillations from the Douglas Model A4D-2 Airplane*, Report ES26613, Douglas Aircraft Company, 20 Mar. 1957.
28. Terrill, W.H., L.R. Springer, and J.G. Wong, *Investigation of Pilot-Induced Longitudinal Oscillation in the Douglas Model A4D-2 Airplane*, Douglas Aircraft Company, Inc., Report LB-25452, 15 May 1957.
29. Jex, H.R., *Summary of T-38A PIO Analysis*, Systems Technology, Inc., TR-239-1, Jan. 1963.
30. Levi, O.A. and W.E. Nelson, "An Analytical and Flight Test Approach to the Reduction of Pilot Induced Oscillation Susceptibility," *J. of Aircraft*, July-Aug. 1964, pp. 178-184.
31. Hirsch, D. and R. McCormick, "Experimental Investigation of Pilot Dynamics in a Pilot-Induced Oscillation Situation," *J. of Aircraft*, Nov.-Dec. 1966.
32. Chalk, C.R., *Another Study of the T-38A PIO Incident*, Calspan Advanced Technology Center, FRM 534, 31 Aug. 1978.
33. Johnson, Donald E. and Raymond E. Magdaleno, *Independent Assessment of C/MH-53E Technical Evaluation Program (TEP)*, Systems Technology, Inc. TR-1251-1R, Sept. 1990.

REFERENCES (continued)

34. Kaplita, Thaddeus T., Joseph T. Driscoll, Myron A. Diftler, and Steven W. Hong, "Helicopter Simulation Development by Correlation with Frequency Sweep Flight Data," *American Helicopter Society 45th National Forum Proceedings*, Boston, MA, May 1989.
35. Aponso, Bimal L., Donald E. Johnston, Walter A. Johnson, Raymond E. Magdaleno, "Identification of Higher-Order Helicopter Dynamics Using Linear Modeling Methods," Systems Technology, Inc. P-464A, *American Helicopter Society, 47th Annual Forum Proceedings*, May 1991, pp 137-153.
36. Norton, William J., Captain, USAF, "Aeroelastic Pilot-in-the-Loop Oscillations," presented at PIO Workshop following *Active Control Technology: Applications and Lessons Learned*, AGARD, Turin, Italy, May 1994.
37. Parham, Tom, Jr., David Popelka, David G. Miller, and Arnold T. Froebel, "V-22 Pilot-in the-Loop Aeroelastic Stability Analysis," *American Helicopter Society, 47th Annual Forum Proceedings*, May 1991
38. Johnston, D.E., and D.T. McRuer, *Investigation of Interactions Between Limb-Manipulator Dynamics and Effective Vehicle Roll Control Characteristics*, NASA CR-3983, May 1986.
39. Johnston, D.E., and B.L. Aponso, *Design Considerations of Manipulator and Feel System Characteristics in Roll Tracking*, NASA CR-4111, Feb. 1988.
40. Mitchell, D.G., B.L. Aponso, D.H. Klyde, *Effects of Lateral Stick Characteristics on Handling Qualities and Pilot Dynamics*, NASA CR-4443, June 1992.
41. Myers, Thomas T., D.H. Klyde, R.E. Magdaleno, Samuel Y. Chan, Peter Y. Cheng, Dale M. Pitt, *Aeroservoelastic Stabilization Techniques for Hypersonic Flight Vehicles*, NASA CR-187614, Sept. 1991.
42. Myers, Thomas T., D.H. Klyde, R.E. Magdaleno, Duane T. McRuer, Samuel Y. Chan, Peter Y. Cheng, *Advanced Aeroservoelastic Stabilization Techniques for Hypersonic Flight Vehicles*, NASA CR-189702, Nov. 1992.
43. Ashkenas, I.L., R.E. Magdaleno, and D.T. McRuer, *Flight Control and Analysis Methods for Studying Flying and Ride Qualities of Flexible Transport Aircraft*, NASA CR-172201, Aug. 1983. (A shorter summary appears as "Flexible Aircraft Flying and Ride Qualities," in *NASA Aircraft Controls Research 1983*, NASA Conference Publication 2296, October 25-27, 1983, Gary P. Beasley, Compiler)
44. McRuer, Duane and Ezra Krendel, *Dynamic Response of Human Operators*, WADC-TR-56-524, Oct. 1957. (Also, "The Human Operator as a Servo System Element," *J. Franklin Inst.*, Vol. 267, No. 5, May 1959, pp. 381-403 and No. 6, June 1959, pp. 511-536)
45. Krendel, Ezra S., and Duane T. McRuer, "A Servomechanisms Approach to Skill Development," *J. Franklin Inst.*, Vol. 269, No. 1, Jan. 1960, pp. 24-42.
46. McRuer, D.T., and H.R. Jex, "A Review of Quasi-Linear Pilot Models," *IEEE. Trans. Human Factors in Electronics.*, Vol. HFE-8, No. 3, Sept. 1967, pp. 231-249.

REFERENCES (continued)

47. Young, L.R., "Human Control Capabilities," J.F. Parker and V.R. West (eds.), 2nd Edition, *Bioastronautics Data Book*, Chapter 16, NASA SP-3006, 1973, pp. 751-806.
48. McRuer, D.T., and E.S. Krendel, *Mathematical Models of Human Pilot Behavior*, AGARDograph No. 188, Jan. 1974.
49. McRuer, D.T., "Human Dynamics in Man-Machine Systems," *Automatica*, Vol. 16, No. 3, May 1980, pp. 237-253.
50. Krendel, E.S., and D.T. McRuer, "Psychological and Physiological Skill Development -- A Control Engineering Model," in A. S. Iberall and J. B. Reswick, (eds.), *Technical and Biological Problems of Control -- A Cybernetic View; Proc. of IFAC Conference*, Instrument Society of America, Pittsburgh, PA, 1970, pp. 657-665; also in *Proc. of Fourth Annual NASA-University Conference on Manual Control*, NASA SP-192, Mar. 1968, pp. 275-288.
51. Allen, R. Wade, and Duane McRuer, "The Man/Machine Control Interface -- Pursuit Control," *Automatica*, Vol. 15, No. 6, Nov. 1979, pp. 683-686.
52. Jagacinski, Richard J. and Sehchang Hah, "Progression-Regression Effects in Tracking Repeated Patterns," *J. Experimental Psychology: Human Perception and Performance*, Vol. 14, No. 1, 1988, pp. 77-88.
53. Magdaleno, R.E., and D.T. McRuer, *Effects of Manipulator Restraints on Human Operator Performance*, AFFDL-TR-66-72, Dec. 1966.
54. McRuer, D.T., and R.E. Magdaleno, *Human Pilot Dynamics with Various Manipulators*, AFFDL-TR-66-138, Dec. 1966.
55. Graham, Dunstan, *Research on the Effect of Nonlinearities on Tracking Performance*, AMRL-TR-67-9, July 1967.
56. Magdaleno, R.E., D.T. McRuer, and G.P. Moore, *Small Perturbation Dynamics of the Neuromuscular System in Tracking Tasks*, NASA CR-1212, Dec. 1968.
57. Jex, H.R., and R.E. Magdaleno, "Biomechanical Models for Vibration Feedthrough to Hands and Head for a Semisupine Pilot," *Aviation, Space and Environ. Med.*, Vol. 49, No. 1, Jan. 1978, pp. 304-316.
58. Hess, Ronald A., "A Model-Based Investigation of Manipulator Characteristics and Pilot/Vehicle Performance," *J. Guidance and Control*, Vol. 6, No. 5, Oct. 1983.
59. *Advances in Flying Qualities*, AGARD Lecture Series No. 157, AGARD-LS-157, 1988.
60. McRuer, Duane, Dunstan Graham, Ezra Krendel, and William Reisner, Jr., *Human Pilot Dynamics in Compensatory Systems: Theory, Models, and Experiments with Controlled Element and Forcing Function Variations*, AFFDL-TR-65-15, July 1965.

REFERENCES (continued)

61. McRuer, Duane T., Warren F. Clement, Peter M. Thompson and Raymond E. Magdaleno, *Minimum Flying Qualities. Volume II: Pilot Modeling for Flying Qualities Applications*, WRDC-TR-89-3125, Vol. II, Jan. 1990.
62. Ellson, J.I. and F. Gray, *Frequency Responses of Human Operators Following a Sine Wave Input*, USAF AMC Memo Rept MCREXD-694-2N, 1948.
63. Allen, R.W., H.R. Jex, and R.E. Magdaleno, *Manual Control Performance and Dynamic Response During Sinusoidal Vibration*, AMRL-TR-73-78, Oct. 1973.
64. Decker, James L., "The Human Pilot and the High-Speed Airplane," *J. Aero Sciences*, Vol. 25, No. 8, Aug. 1956, pp. 765-770.
65. Phillips, William H., B. Porter Brown, and James T. Mathews, *Review and Investigation of Unsatisfactory Control Characteristics Involving Instability of Pilot-Airframe Combination and Methods for Predicting These Difficulties from Ground Test*, NACA TN 4064, Aug. 1957.
66. McRuer, Duane T., Irving L. Ashkenas, and C.L. Guerre, *A Systems Analysis View of Longitudinal Flying Qualities*, WADD TR-60-43, Jan. 1960.
67. Ashkenas, I.L., and D.T. McRuer, *The Determination of Lateral Handling Quality Requirements from Airframe-Human Pilot System Studies*, WADD-TR-59-135, June 1959.
68. Harper, Robert P., Jr., *In-Flight Simulation of the Lateral-Directional Handling Qualities of Entry Vehicles*, WADD TR-61-147, Feb. 1961.
69. Ashkenas, I.L., and D.T. McRuer, "A Theory of Handling Qualities Derived from Pilot-Vehicle System Considerations," *Aerospace Engineer*, Vol. 21, No. 2, Feb. 1962, pp. 60-102.
70. Caporali, R.L., J.P. Lamers, and J.R. Totten, *A Study of Pilot-Induced Lateral-Directional Instabilities*, Princeton Univ., Aeronautical Engineering Dept Report 604, May 1962.
71. Durand, T.S., and H.R. Jex, *Handling Qualities in Single-Loop Roll Tracking Tasks: Theory and Simulator Experiments*, ASD TDR-62-507, Nov. 1962.
72. Bjorkman, Eileen A., Captain, USAF, *Flight Test Evaluation of Techniques to Predict Longitudinal Pilot Induced Oscillations*, Thesis AFIT/GAE/AA/86J-1, Air Force Institute of Technology, Wright-Patterson Air Force Base, Ohio, Dec. 1986.
73. DiFranco, Dante A., *Flight Investigation of Longitudinal Short Period Frequency Requirements and PIO Tendencies*, AFFDL-TR-66-163, June 1967.
74. Cooper, George E. and Robert P. Harper, Jr., *The Use of Pilot Rating in the Evaluation of Aircraft Handling Qualities*, NASA TN D-5153, Apr. 1969.
75. McRuer Duane, "Estimation of Pilot Rating via Pilot Modeling," *Flying Qualities*, AGARD CP-508, 15-18 Oct. 1990, Quebec City, Canada.
76. Smith, Rogers E., *Effects of Control System Dynamics on Fighter Approach and Landing Longitudinal Flying Qualities (Volume 1)*, AFFDL-TR-122, Mar. 1978.

REFERENCES (concluded)

77. Klyde, David H., David G. Mitchell, and Irving L. Ashkenas, "Proposed Time Delay Limits for DFBW Transports in Precision Landing," *Appendix K in Certification/Safety Assessment Criteria and Considerations for Advanced Digital Fly-By-Wire (DFBW) Transport Aircraft*, Systems Technology, Inc., TR-1284-1, May 1993.
78. Kempel, Robert W., Weneth D. Painter, and Milton O. Thompson, *Developing and Flight Testing the HL-10 Lifting Body: A Precursor to the Space Shuttle*, NASA Reference publication 1332, Apr. 1994.
79. Garland, Michael P., Michael K. Nelson, and Richard C. Patterson, *F-16 Flying Qualities with External Stores*, AFFTC-TR-80-29, Feb. 1981.
80. Barnes, A.G., "The Role of Simulation in Flying Qualities and Flight Control System Related Development," in *Advances in Flying Qualities*, AGARD-LS-157, 1988.
81. Graham, Dunstan and Duane McRuer, *Analysis of Nonlinear Control Systems*, John Wiley and Sons, Inc., New York, 1961. (Also Dover, 1971)
82. Gibson, John C., "Piloted Handling Qualities Design Criteria for High Order Flight Control Systems," *Criteria for Handling Qualities of Military Aircraft*, AGARD CP-333, Apr. 1982.

BIBLIOGRAPHY

- A'Harrah, Ralph C., "Low-Altitude, High-Speed Handling and Riding Qualities," *J. of Aircraft*, Vol. 1, 1964, pp. 32-40.
- A'Harrah, Ralph C., "Reply by Author to I.L. Ashkenas," *J. of Aircraft*, July-Aug. 1964, pp. 223-224.
- A'Harrah, R.C., and R.F. Siewert, *Pilot-Induced Instability*, AGARD CP-17, Part II, 1966.
- Abzug, Malcolm J., *High-Speed Stability and Control Problems as They Affect Flight Testing*, AGARD AG-120, May 1957.
- Ashkenas, I.L., "Comment on Low-Altitude, High-Speed Handling and Riding Qualities," *J. of Aircraft*, July-Aug. 1964, pp. 222-223.
- Ashkenas, I.L., "Further Comment on Low-Altitude, High-Speed Handling and Riding Qualities," *J. of Aircraft*, Nov.-Dec. 1964, p. 377.
- Hess, R.A., "Pursuit Tracking and Higher Levels of Skill Development in the Human Pilot," *IEEE Transactions on Systems, Man, and Cybernetics*, Vol. 11, 1981, pp. 262-273.
- Hess, Ronald A., "Analysis of Aircraft Attitude Control Systems Prone to Pilot-Induced Oscillations," *J. Guidance, Control, and Dynamics*, Vol. 7, No. 1, Jan-Feb. 1984, pp. 106-112.
- Jex, H.R., and C.H. Cromwell, III, *Theoretical and Experimental Investigation of Some New Longitudinal Handling Qualities Parameters*, ASD TDR-61-26, June 1962.
- Magdaleno, R.E., H.R. Jex, and W.A. Johnson, "Tracking Quasi-Predictable Displays: Subjective Predictability Gradations, Pilot Models for Periodic and Narrowband Inputs," *5th Annual NASA-University Conference on Manual Control*, NASA SP-215, 1970, pp. 391-428.
- Magdaleno, R.E., and D.T. McRuer, *Experimental Validation and Analytical Elaboration for Models of the Pilot's Neuromuscular Subsystem in Tracking Tasks*, NASA CR-1757, Apr. 1971.
- Seckel, Edward, Ian A.M. Hall, Duane T. McRuer, and David H. Weir, *Human Pilot Dynamic Response in Flight and Simulator*, WADC-TR-57-520, Aug. 1958.
- Sheridan, R.B., and W.R. Ferrell, *Man-Machine Systems: Information, Control, and Decision Models of Human Performance*, MIT Press Cambridge, 1974.
- Smith, R.H., *Aircraft Handling Qualities Technology Assessment with Emphasis on Pilot-Induced Oscillations: A Failure of Leadership*, HPE-92-01, High Plains Engineering, Tehachapi, CA, June 1992.

REPORT DOCUMENTATION PAGE

Form Approved
OMB No. 0704-0188

Public reporting burden for this collection of information is estimated to average 1 hour per response, including the time for reviewing instructions, searching existing data sources, gathering and maintaining the data needed, and completing and reviewing the collection of information. Send comments regarding this burden estimate or any other aspect of this collection of information, including suggestions for reducing this burden, to Washington Headquarters Services, Directorate for Information Operations and Reports, 1215 Jefferson Davis Highway, Suite 1204, Arlington, VA 22202-4302, and to the Office of Management and Budget, Paperwork Reduction Project (0704-0188), Washington, DC 20503.

| | | | | |
|--|---|--|---|--|
| 1. AGENCY USE ONLY (Leave blank) | | 2. REPORT DATE July 1995 | 3. REPORT TYPE AND DATES COVERED Contractor Report | |
| 4. TITLE AND SUBTITLE Pilot-Induced Oscillations and Human Dynamic Behavior | | | 5. FUNDING NUMBERS WU 505-64-30 TSD-93-STI-2806 | |
| 6. AUTHOR(S) Duane T. McRuer | | | | |
| 7. PERFORMING ORGANIZATION NAME(S) AND ADDRESS(ES) Systems Technology, Inc. 13766 South Hawthorne Blvd. Hawthorne, CA 90250 | | | 8. PERFORMING ORGANIZATION REPORT NUMBER TR-2494-1 | |
| 9. SPONSORING/MONITORING AGENCY NAME(S) AND ADDRESS(ES) PRC Inc. Dryden Flight Research Center Edwards, CA 93523-0273 | | | 10. SPONSORING/MONITORING AGENCY REPORT NUMBER H-2042 NASA CR-4683 | |
| 11. SUPPLEMENTARY NOTES The NASA Technical Monitor at Dryden Flight Research Center was Dwain Deets. This report was previously published as NASA CR-186032. | | | | |
| 12a. DISTRIBUTION/AVAILABILITY STATEMENT Unclassified—Unlimited Subject Category 08 | | | 12b. DISTRIBUTION CODE | |
| 13. ABSTRACT (Maximum 200 words) This is an in-depth survey and study of Pilot-Induced Oscillations (PIOs) as interactions between human pilot and vehicle dynamics; it includes a broad and comprehensive theory of PIOs. A historical perspective provides examples of the diversity of PIOs in terms of control axes and oscillation frequencies. The constituents involved in PIO phenomena, including effective aircraft dynamics, human pilot dynamic behavior patterns, and triggering precursor events, are examined in detail as the structural elements interacting to produce severe pilot-induced oscillations. The great diversity of human pilot response patterns, excessive lags and/or inappropriate gain in effective aircraft dynamics, and transitions in either the human or effective aircraft dynamics are among the key sources implicated as factors in severe PIOs. The great variety of interactions which may result in severe PIOs is illustrated by examples drawn from famous PIOs. These are generalized under a pilot-behavior-theory-based set of categories proposed as a classification scheme pertinent to a theory of PIOs. Finally, a series of interim prescriptions to avoid PIO is provided. | | | | |
| 14. SUBJECT TERMS Active control technology; Aircraft dynamics; Aircraft-pilot coupling; Flight control; Flying qualities; Manual control; Pilot dynamics; Pilot-Induced Oscillations | | | 15. NUMBER OF PAGES 102 | |
| | | | 16. PRICE CODE AO6 | |
| 17. SECURITY CLASSIFICATION OF REPORT Unclassified | 18. SECURITY CLASSIFICATION OF THIS PAGE Unclassified | 19. SECURITY CLASSIFICATION OF ABSTRACT Unclassified | 20. LIMITATION OF ABSTRACT Unlimited | |



