

NASA Technical Memorandum 110243

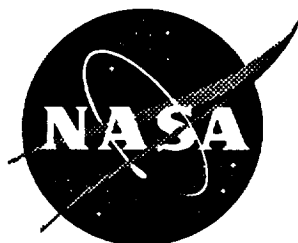

An Extended Compact Tension Specimen for Fatigue Crack Propagation and Fracture

R. S. Piascik and J. C. Newman, Jr.
Langley Research Center, Hampton, Virginia

March 1996

National Aeronautics and
Space Administration
Langley Research Center
Hampton, Virginia 23681-0001

AN EXTENDED COMPACT TENSION SPECIMEN FOR FATIGUE CRACK PROPAGATION AND FRACTURE

R. S. Piascik and J.C. Newman, Jr.
Mechanics of Materials Branch
NASA Langley Research Center, M.S. 188E
Hampton, Virginia 23681-0001

ABSTRACT

An extended compact tension specimen, EC(T) has been developed for fatigue and fracture testing. Documented herein are stress-intensity factor and compliance expressions for the EC(T) specimen.

BACKGROUND

Current research programs at NASA Langley Research Center (LaRC), on Aging Aircraft and High Speed Civil Transport Research, have culminated in the development of a versatile extended compact tension specimen, EC(T), for studying fatigue crack growth and fracture behavior of metallic materials. The elongated compact tension configuration, first studied by Richardson and Goree [1] for ceramic materials fracture testing, is easily adaptable to environmental fatigue crack growth studies. The particular EC(T) specimen configuration, shown in Figure 1(a), was initially developed at NASA LaRC for first-of-the-kind studies of environmental fatigue crack propagation of small surface cracks and long through-the-thickness cracks in aluminum alloys [2].

The pin loaded extended compact tension specimen EC(T) is considered an optimum design for laboratory fatigue crack growth and fracture studies because:

1. The elongated (extended) design gives the experimenter additional working room compared to the standard compact tension C(T) configuration. This configuration lends itself to attaching complex displacement or strain gage measurement systems and environmental cells.
2. The specimen configuration requires lower applied loads for equivalent crack tip stress-intensity factor (K) compared to other specimen configurations, such as the single edge notch SE(T) and

middle notch M(T) specimens. This results in lower net section stress and reduces the likelihood of premature fracture of sheet materials tested in highly corrosive environments.

3. The sharp and blunt configurations shown in Figures (1b) and (1c), respectively, were designed for long and small crack growth testing. The sharp notch geometry, shown in Figure (1b), incorporates integral knife edges for front face compliance based long crack length monitoring. The blunt notch design allows the use of optical microscopy for the *in situ* observation of crack initiation and the crack length measurement of small surface and corner cracks (see [2]).
4. The specimen design is compatible with common automated techniques for the measurement of through-the-thickness crack lengths.
5. The specimen design reduces the T-stress (stress parallel to crack surface) and crack fracture paths are more self-similar than in the standard C(T) specimen [1].
6. The EC(T) specimen length is long enough so that standard compact tension specimens may be machined from the broken halves for comparison studies.
7. The EC(T) blunt-notch specimen may be used as a fatigue specimen with various stress concentrations by varying the notch root radius.

STRESS-INTENSITY FACTOR

The stress-intensity factor solution for the EC(T) specimen was derived by the boundary-force method (BFM) [3]. (Note that the EC(T) blunt notch configuration stress-intensity factor expressions for surface and corner cracks are documented elsewhere [2].) Calculated values of normalized stress-intensity factor $F_{EC(T)}$, normalized displacement (EBV/P) at the crack mouth V_0 ($x/W=0$) and near the crack mouth V_1 ($x/W=0.05$), and normalized back-face strain, $(-\epsilon/P)BWE$, as a function of c/W are summarized in Table 1. The stress-intensity factor equation developed to fit the BFM results is given by

$$K = [P/(B\sqrt{W})]F_{EC(T)} \quad (1)$$

where

P = load
B = thickness
W = width

and

$$F_{EC(T)} = (2+\lambda)/[(1-\lambda)^{3/2}(1-d/W)^{1/2}]G \quad (2)$$

where

$$G = 1.15 + 0.94\lambda - 2.48\lambda^2 + 2.95\lambda^3 - 1.24\lambda^4$$
$$\lambda = (c-d)/(W-d)$$

c = crack length
d = distance from specimen edge to load line

for $0.1 \leq c/W < 1$. The semi-log plot shown in Figure 2 is a comparison of equation (2) and the BFM results. The stress-intensity factor equation is within ± 0.5 percent of the BFM results for c/W ratios from 0.1 to 0.84; and the stress intensity factor approaches the correct theoretical limit as c/W approaches unity

CRACK LENGTH - COMPLIANCE

Front-face: The compliance method for through-the-thickness crack length monitoring can be used during EC(T) fatigue crack growth testing. Expressions that relate compliance and crack length have been developed for front-face displacement and back-face strain measurement methods. The following expression was derived for monitoring crack length by measuring displacements at the front face. Refer to Figure (1b) and location X₁, the specimen front face (knife edge region).

$$c/W = M_0 + M_1 U + M_2 U^2 + M_3 U^3 + M_4 U^4 + M_5 U^5 \quad (3)$$

where:

$$U = [(EV_0 B/P)^{1/2} + 1]^{-1}$$

$$M_0 = 1.00132$$

$$M_1 = -3.58451$$

$$M_2 = 6.599541$$

$$M_3 = -19.22577$$

$$M_4 = 41.54678$$

$$M_5 = -31.75871$$

E = Young's modulus

U = normalized crack mouth displacement

for $0.1 \leq c/W < 1$. A comparison of equation (3) and the BFM results are shown in semi-log plot in Figure 3. The equation for c/W is within ± 0.03 percent for a given compliance, EV_0B/P , for c/W ratios from 0.1 to 0.84.

Back-face: The following expression was derived for monitoring crack length by measuring strains at the back-face. Here, back-face strain, ϵ , is measured at a location along the crack plane, shown as point X_2 in Figure (1a).

$$c/W = N_0 + N_1(\log A) + N_2(\log A)^2 + N_3(\log A)^3 + N_4(\log A)^4 \quad (4)$$

where:

$$A^* = -(\epsilon/P)BWE$$

$$N_0 = 0.09889$$

$$N_1 = 0.41967$$

$$N_2 = 0.06751$$

$$N_3 = -0.07018$$

$$N_4 = 0.01082$$

for $0.1 \leq c/W < 1$. The semi-log plot shown in Figure 4 is a comparison of equation (4) and the BFM results. The equation for c/W is within ± 0.2 percent for a given normalized strain, $|(\epsilon/P)BWE|$, for c/W ratios from 0.3 to 0.84 (within about 2 percent for $c/W < 0.3$). A test was conducted on 2024-T3 aluminum alloy ($B = 2.3$ mm) to experimentally determine the crack length against back-face strain relation and these results are shown as square symbols. Agreement between the test and analyses was 5 percent.

CONCLUDING REMARKS

An extended compact tension specimen configuration is proposed. Stress-intensity factor and crack length-compliance equations (crack mouth displacement and back face strain) are developed for the new specimen configuration.

As a result of the work performed at NASA LaRC, the EC(T) specimen is currently being used for fatigue and fracture testing by a number of organizations, including private industry, government laboratories and Universities. To date, the

specimen has been used successfully for fatigue and fracture studies and environmental and elevated temperature testing for a variety of material systems (aluminum alloys, titanium alloys, metal matrix composites and ceramic materials). Testing has included all common laboratory techniques including front and back face compliance and electric potential drop crack length measurements. The specimen has also been used for more complex crack closure and small crack studies.

ACKNOWLEDGMENT

The authors gratefully acknowledge D.S. Dawicke, Analytical Services and Materials, Inc. for developing the EC(T) front-face compliance equation (eqn. 3).

REFERENCES

1. Richardson, D. E. and Goree. J. G., Experimental Verification of a New Two-Parameter Fracture Model, *ASTM STP 1189*, R. Chona, ed. (1993) 738-750.
2. Piascik, R. S. and Willard, S. A., The Growth of Small Corrosion Fatigue Cracks in Alloy 2034, *Fatigue Fract. Engng. Mater. Struct.*, Vol. 17, No. 11 (1994) 1247-1259.
3. Tan, P. W., Raju, I. S. and Newman, J. C., Jr., Boundary Force Method for Analyzing Two-Dimensional Cracked Plates, *ASTM STP 945*, D. T. Read and R. P. Reed, eds. (1988) 259-277.

Table 1 - Stress Intensity Factors and Crack-Opening Displacements for the EC(T)
Specimen from BFM Analyses

c/W	$F_{EC(T)}$	EBV_0/P	EBV_1/P	$(-\varepsilon/P)BWE$
0.10	1.721	1.664	1.180	1.023
0.15	2.155	2.622	2.117	1.303
0.20	2.586	3.750	3.194	1.692
0.25	3.049	5.127	4.497	2.209
0.30	3.571	6.853	6.126	2.883
0.35	4.178	9.072	8.215	3.765
0.40	4.904	11.99	10.96	4.925
0.45	5.792	15.91	14.65	6.469
0.50	6.907	21.33	19.74	8.569
0.55	8.343	29.02	26.97	11.50
0.60	10.25	40.30	37.59	15.70
0.65	12.88	57.58	53.87	22.00
0.70	16.67	85.51	80.21	31.94
0.725	19.24	106.2	99.74	39.16
0.75	22.48	134.1	126.0	48.76
0.775	26.66	172.6	162.4	61.83
0.80	32.21	227.6	214.5	80.22
0.825	39.84	309.7	292.1	107.2
0.84	45.90	379.6	358.2	144.2

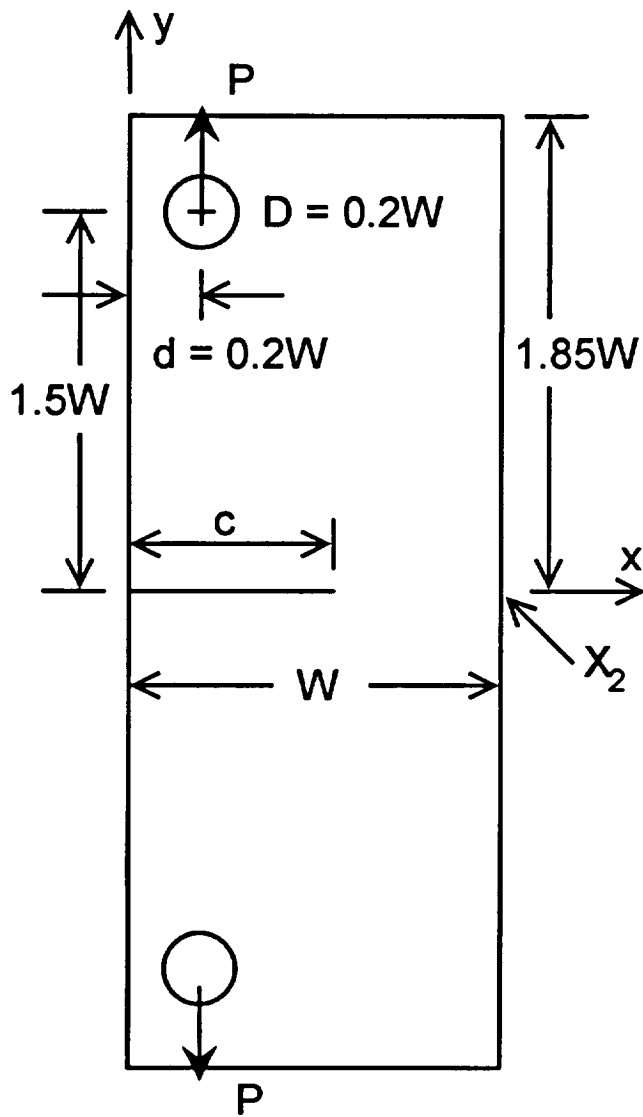

(a) EC(T) Specimen.

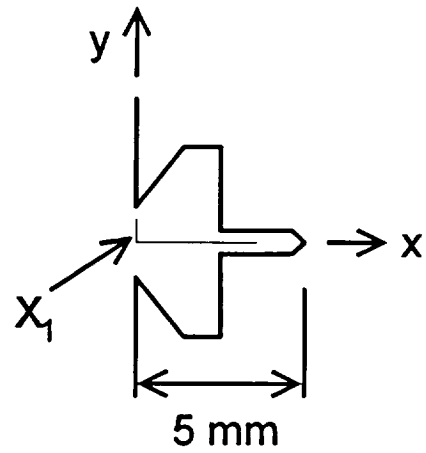

(b) Displacement-Gage Notch ($W = 38\text{ mm}$).

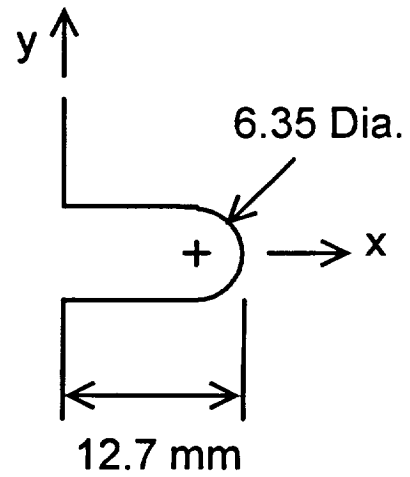

(c) Blunt-Notch ($W = 38\text{ mm}$).

Fig. 1. - Extended compact tension specimen and notch details.

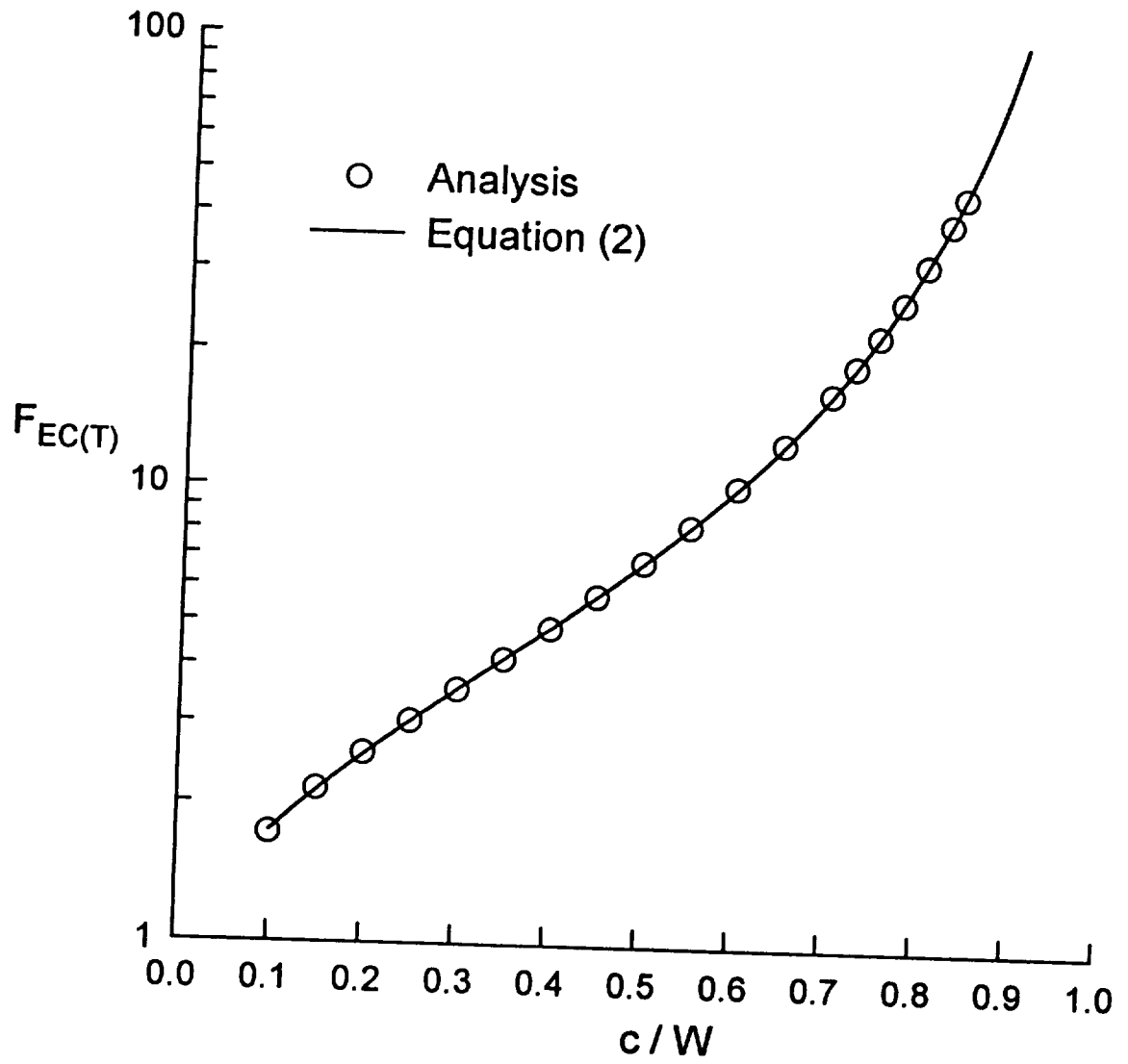

Fig. 2. - Normalized stress-intensity factors for EC(T) specimen.

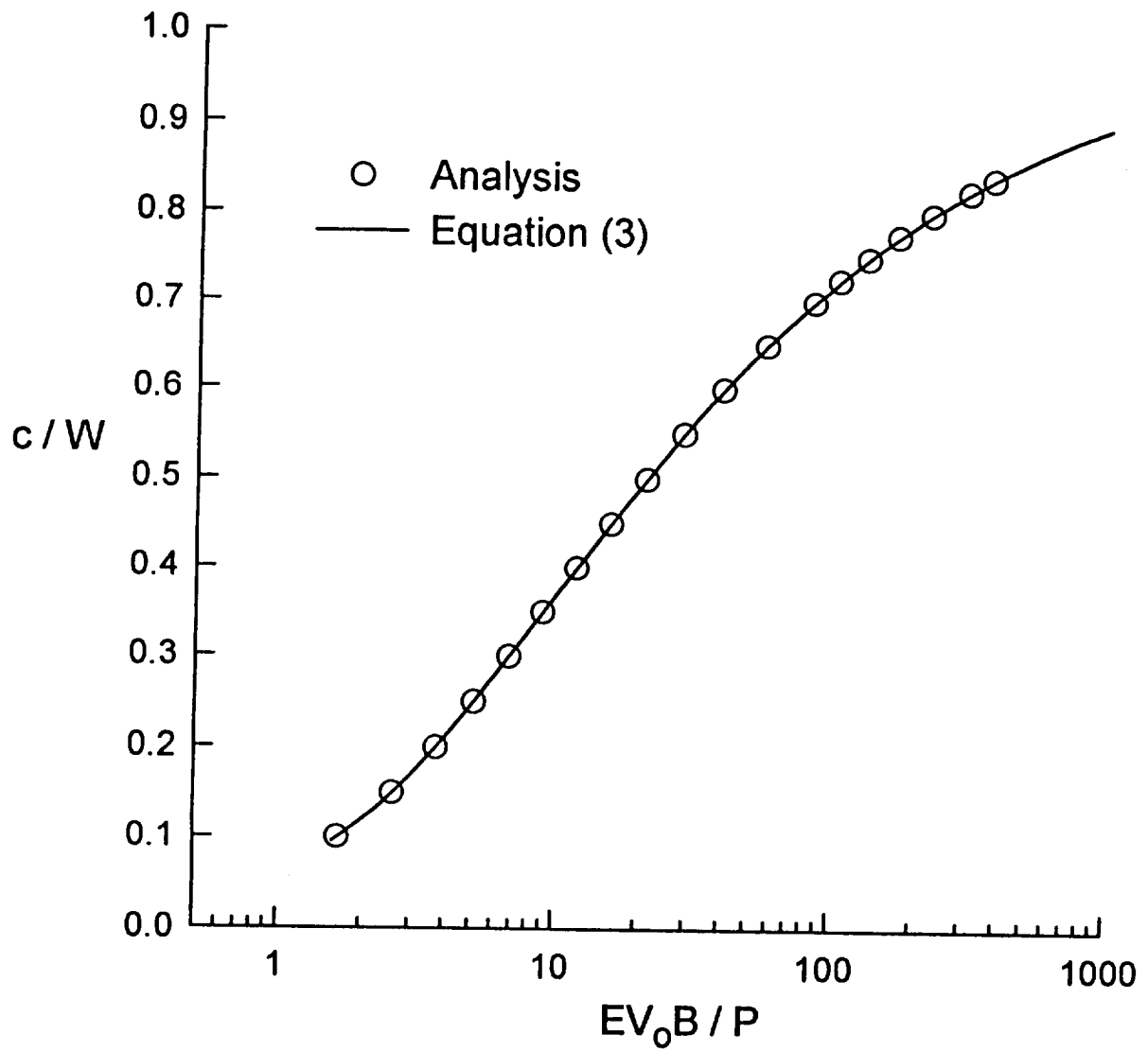

Fig. 3. - Crack length and front-face compliance relation.

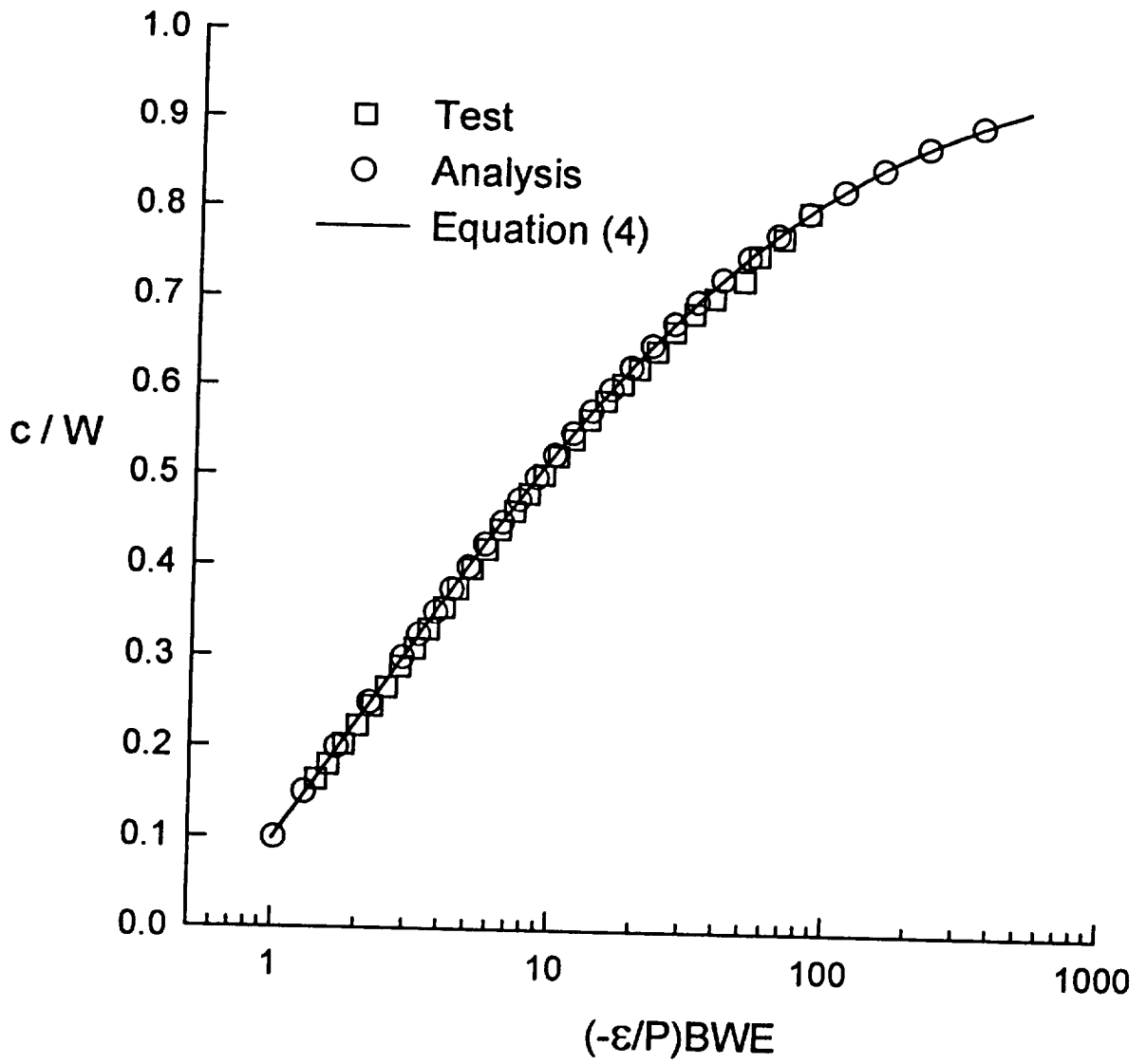

Fig. 4. - Crack length and back-face strain relation.

REPORT DOCUMENTATION PAGE

Form Approved
OMB No. 0704-0188

Public reporting burden for this collection of information is estimated to average 1 hour per response, including the time for reviewing instructions, searching existing data sources, gathering and maintaining the data needed, and completing and reviewing the collection of information. Send comments regarding this burden estimate or any other aspect of this collection of information, including suggestions for reducing this burden, to Washington Headquarters Services, Directorate for Information Operations and Reports, 1215 Jefferson Davis Highway, Suite 1204, Arlington, VA 22202-4302, and to the Office of Management and Budget, Paperwork Reduction Project (0704-0188), Washington, DC 20503.

1. AGENCY USE ONLY (Leave blank)		2. REPORT DATE March 1996	3. REPORT TYPE AND DATES COVERED Technical Memorandum	
4. TITLE AND SUBTITLE An Extended Compact Tension Specimen for Fatigue Crack Propagation and Fracture			5. FUNDING NUMBERS WU 538-02-10-01	
6. AUTHOR(S) R. S. Piascik and J. C. Newman, Jr.				
7. PERFORMING ORGANIZATION NAME(S) AND ADDRESS(ES) NASA Langley Research Center Hampton, VA 23681-0001			8. PERFORMING ORGANIZATION REPORT NUMBER	
9. SPONSORING / MONITORING AGENCY NAME(S) AND ADDRESS(ES) National Aeronautics and Space Administration Washington, DC 20546-0001			10. SPONSORING / MONITORING AGENCY REPORT NUMBER NASA TM-110243	
11. SUPPLEMENTARY NOTES Piascik and Newman, Jr.: Langley Research Center, Hampton, VA				
12a. DISTRIBUTION / AVAILABILITY STATEMENT Unclassified - Unlimited Subject Category 24			12b. DISTRIBUTION CODE	
13. ABSTRACT (Maximum 200 words) An extended compact tension specimen, EC(T) has been developed for fatigue and fracture testing. Documented herein are stress-intensity factor and compliance expressions for the EC(T) specimen.				
14. SUBJECT TERMS Crack; Stress-intensity; Factor; Displacements; Strains; Stress analysis			15. NUMBER OF PAGES 11	
			16. PRICE CODE A03	
17. SECURITY CLASSIFICATION OF REPORT Unclassified	18. SECURITY CLASSIFICATION OF THIS PAGE Unclassified	19. SECURITY CLASSIFICATION OF ABSTRACT	20. LIMITATION OF ABSTRACT	

