

Analysis of the two-point velocity correlations in turbulent boundary layer flows

By M. Oberlack

1. Motivation and objectives

Two-point *Rapid Distortion Theory* (RDT) has become an important tool in the theory of homogeneous turbulence. Modelers try to implement appropriate results from RDT in their statistical turbulence models, for example in the structure based model developed by Kassinos and Reynolds (1994).

On the other hand, in non-homogeneous equilibrium flows the logarithmic law is one of the cornerstones in statistical turbulence theory. Experimentalists have found the log-law in a broad variety of different turbulent wall shear flows, and statistical models have been made to be consistent with the log-law.

The logarithmic law was first derived by von Kármán (1930a, 1930b) using dimensional arguments. Later Millikan (1939) derived the law-of-the-wall more formally using the so called “velocity defect law”, also first introduced by von Kármán (1930b). Even though the derivation was much more comprehensive from a physical point of view, the velocity defect law is essentially an empirical observation. A first derivation of the law-of-the-wall using asymptotic methods in the Navier-Stokes equations was given by Mellor (1972). Mellor needed the viscous sub-layer to obtain the log-region, and his scaling of the inertial range in the log-region is in error because it does not give the one-point limit of production equals dissipation.

The general objective of the present work is to explore the use of RDT in analysis of the two-point statistics of the log-layer. RDT is applicable only to unsteady flows where the non-linear turbulence-turbulence interaction can be neglected in comparison to linear turbulence-mean interactions. Here we propose to use RDT to examine the structure of the large energy-containing scales and their interaction with the mean flow in the log-region.

The contents of the work are twofold: First, two-point analysis methods will be used to derive the law-of-the-wall for the special case of zero mean pressure gradient. The basic assumptions needed are one-dimensionality in the mean flow and homogeneity of the fluctuations. It will be shown that a formal solution of the two-point correlation equation can be obtained as a power series in the von Kármán constant, known to be on the order of 0.4.

In the second part, a detailed analysis of the two-point correlation function in the log-layer will be given. The fundamental set of equations and a functional relation for the two-point correlation function will be derived. An asymptotic expansion procedure will be used in the log-layer to match Kolmogorov’s universal range and the one-point correlations to the inviscid outer region valid for large correlation distances.

2. Governing equations of the two-point velocity correlation function

Using the standard Reynolds decomposition $U_i = \bar{u}_i + u_i$ and $P = \bar{p} + p$, the Reynolds averaged Navier Stokes (RANS) equations read

$$\frac{\partial \bar{u}_i}{\partial t} + \bar{u}_k \frac{\partial \bar{u}_i}{\partial x_k} = -\frac{1}{\rho} \frac{\partial \bar{p}}{\partial x_i} + \nu \frac{\partial^2 \bar{u}_i}{\partial x_k^2} - \frac{\partial \overline{u_i u_k}}{\partial x_k} \quad (1)$$

and the fluctuation equation, later on referred to as \mathcal{N} -equation, is

$$\mathcal{N}_i(\mathbf{x}) = \frac{\partial u_i}{\partial t} + \bar{u}_k \frac{\partial u_i}{\partial x_k} + u_k \frac{\partial \bar{u}_i}{\partial x_k} - \frac{\partial \overline{u_i u_k}}{\partial x_k} + \frac{\partial u_i u_k}{\partial x_k} + \frac{1}{\rho} \frac{\partial p}{\partial x_i} - \nu \frac{\partial^2 u_i}{\partial x_k^2} = 0 . \quad (2)$$

The corresponding continuity equations are

$$\frac{\partial \bar{u}_k}{\partial x_k} = 0 \quad \text{and} \quad \frac{\partial u_k}{\partial x_k} = 0 . \quad (3)$$

The five two-point correlation tensor functions that appear in the two-point correlation equation (5), further below, are defined as

$$\begin{aligned} R_{ij}(\mathbf{x}, \boldsymbol{\tau}; t) &= \overline{u_i(\mathbf{x}, t) u_j(\mathbf{x}^{(1)}, t)} , \\ \overline{p u_j}(\mathbf{x}, \boldsymbol{\tau}; t) &= \overline{p(\mathbf{x}, t) u_j(\mathbf{x}^{(1)}, t)} , \\ \overline{u_j p}(\mathbf{x}, \boldsymbol{\tau}; t) &= \overline{u_j(\mathbf{x}, t) p(\mathbf{x}^{(1)}, t)} , \\ R_{(ik)j}(\mathbf{x}, \boldsymbol{\tau}; t) &= \overline{u_i(\mathbf{x}, t) u_k(\mathbf{x}, t) u_j(\mathbf{x}^{(1)}, t)} , \\ R_{i(jk)}(\mathbf{x}, \boldsymbol{\tau}; t) &= \overline{u_i(\mathbf{x}, t) u_j(\mathbf{x}^{(1)}, t) u_k(\mathbf{x}^{(1)}, t)} . \end{aligned} \quad (4)$$

All tensors in (4) are functions of the physical and the correlation space coordinates \mathbf{x} and $\boldsymbol{\tau} = \mathbf{x}^{(1)} - \mathbf{x}$ respectively. The double two-point correlation R_{ij} , later on simply referred to as two-point correlation, converges to the Reynolds stress tensor $\overline{u_i u_j}$ in the limit of zero separation $\boldsymbol{\tau}$.

The well known two-point correlation equation (Rotta (1972)) can be written as

$$\begin{aligned} \frac{DR_{ij}}{Dt} &= -R_{kj} \frac{\partial \bar{u}_i(\mathbf{x}, t)}{\partial x_k} - R_{ik} \frac{\partial \bar{u}_j(\mathbf{x}, t)}{\partial x_k} \Big|_{\mathbf{x}+\boldsymbol{\tau}} - [\bar{u}_k(\mathbf{x} + \boldsymbol{\tau}, t) - \bar{u}_k(\mathbf{x}, t)] \frac{\partial R_{ij}}{\partial r_k} \\ &\quad - \frac{1}{\rho} \left[\frac{\partial \overline{p u_j}}{\partial x_i} - \frac{\partial \overline{p u_j}}{\partial r_i} + \frac{\partial \overline{u_i p}}{\partial r_j} \right] + \nu \left[\frac{\partial^2 R_{ij}}{\partial x_k \partial x_k} - 2 \frac{\partial^2 R_{ij}}{\partial x_k \partial r_k} + 2 \frac{\partial^2 R_{ij}}{\partial r_k \partial r_k} \right] \\ &\quad - \frac{\partial R_{(ik)j}}{\partial x_k} + \frac{\partial}{\partial r_k} [R_{(ik)j} - R_{i(jk)}] \end{aligned} \quad (5)$$

For both two-point velocity-pressure correlations, $\overline{u_i p}$ and $\overline{p u_j}$ a Poisson equation can be derived. The divergence $\partial/\partial x_i - \partial/\partial r_i$ of equation (5) leads to a Poisson equation for $\overline{p u_j}$,

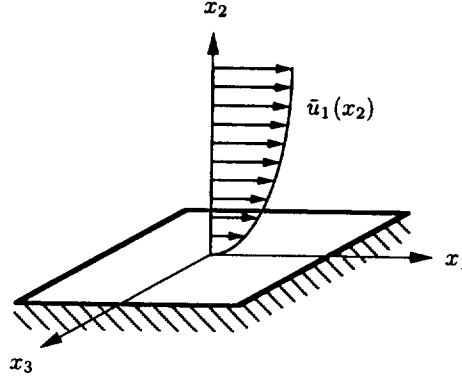

FIGURE 1. Sketch of the coordinate system and the mean velocity field

$$\frac{1}{\rho} \left[\frac{\partial^2 \overline{pu_j}}{\partial x_k \partial x_k} - 2 \frac{\partial^2 \overline{pu_j}}{\partial r_k \partial x_k} + \frac{\partial^2 \overline{pu_j}}{\partial r_k \partial r_k} \right] = -2 \frac{\partial \overline{u_k(\mathbf{x}, t)}}{\partial x_l} \left[\frac{\partial R_{lj}}{\partial x_k} - \frac{\partial R_{lj}}{\partial r_k} \right] - \left[\frac{\partial^2 R_{(kl)j}}{\partial x_k \partial x_l} - 2 \frac{\partial^2 R_{(kl)j}}{\partial x_k \partial r_l} + \frac{\partial^2 R_{(kl)j}}{\partial r_k \partial r_l} \right] \quad (6)$$

and the divergence $\partial/\partial r_j$ leads to the corresponding Poisson equation for $\overline{u_i p}$,

$$\frac{1}{\rho} \frac{\partial^2 \overline{u_i p}}{\partial r_k \partial r_k} = -2 \frac{\partial \overline{u_k(\mathbf{x}, t)}}{\partial x_l} \Big|_{\mathbf{x}+\mathbf{r}} \frac{\partial R_{il}}{\partial r_k} - \frac{\partial^2 R_{i(kl)}}{\partial r_k \partial r_l} \quad (7)$$

where the vertical line means that the derivative is taken with respect to \mathbf{x} but will be evaluated at $\mathbf{x} + \mathbf{r}$. All of the dependent variables in (5)–(7) have to satisfy the continuity conditions

$$\frac{\partial R_{ij}}{\partial x_i} - \frac{\partial R_{ij}}{\partial r_i} = 0, \quad \frac{\partial R_{ij}}{\partial r_j} = 0 \quad (8)$$

$$\frac{\partial \overline{pu_j}}{\partial r_j} = 0 \quad \text{and} \quad \frac{\partial \overline{u_i p}}{\partial x_i} - \frac{\partial \overline{u_i p}}{\partial r_i} = 0. \quad (9)$$

For the analysis of the self-similar, two-point correlation equation further below, two identities are important. They can easily be derived from a geometrical consideration by interchanging the two points \mathbf{x} and $\mathbf{x}^{(1)} = \mathbf{x} + \mathbf{r}$

$$R_{ij}(\mathbf{x}, \mathbf{r}) = R_{ji}(\mathbf{x} + \mathbf{r}, -\mathbf{r}), \quad \overline{u_i p}(\mathbf{x}, \mathbf{r}) = \overline{pu_i}(\mathbf{x} + \mathbf{r}, -\mathbf{r}). \quad (10)$$

The latter identities are the key elements for the derivation of some boundary conditions and for the deeper understanding of the self-similar two-point correlations. There exists a similar identity for the triple correlation which will not be used here.

3. The log-law – a self-similar form of the two-point correlation equation

A sketch of the coordinate system and the mean velocity field adopted in the proceeding paper is given in Fig. 1. Within this subsection it will be shown that the logarithmic part of the law-of-the-wall mean velocity profile can be derived from the two-point correlation equation and hence from the Navier-Stokes equation if there exists a regime where the following assumptions hold:

- the mean velocity is parallel to the wall;
- the statistics in that domain are independent of viscosity and time;
- the Reynolds number is high;
- no mean pressure acts on the flow field.

The last assumption can be eliminated, but in this approach it will be focused on the zero pressure gradient case. Beside the above assumptions no other conditions are needed in order to determine the log-law mean velocity profile and the self-similarity of the correlation functions.

Inferring the above assumption in the Reynolds averaged Navier-Stokes equations (1), it is easy to confirm that the gradient of the Reynolds stress tensor on the right hand side is the only remaining term. Integrated one time we obtain that $\overline{u_i u_j}$ is independent of \mathbf{x} . However, this is not necessarily true for the two-point correlation tensor R_{ij} . It could depend on \mathbf{x} if the dependence vanishes in the zero separation limit. This can only be achieved by having the following dependence on a new variable

$$\tilde{\mathbf{r}} = \mathbf{r}g(\mathbf{x}) \quad (11)$$

where $g(\mathbf{x})$ has to be determined later and no other hidden dependence on \mathbf{x} can be in the correlation functions. Of course, the latter definition of $\tilde{\mathbf{r}}$ can be generalized to different unknown scaling functions for every component of \mathbf{r} , but from equation (5) it can be verified that only a single scaling function exists. With the above given assumptions, defining $\mathbf{x} = \tilde{\mathbf{x}}$ and using the transformation rules

$$\frac{\partial}{\partial x_i} = \frac{\partial}{\partial \tilde{x}_i} + \frac{1}{g} \frac{\partial g}{\partial \tilde{x}_i} \tilde{r}_k \frac{\partial}{\partial \tilde{r}_k}, \quad \frac{\partial}{\partial r_k} = g \frac{\partial}{\partial \tilde{r}_k} \quad (12)$$

the R_{ij} -equation (5) reduces to

$$\begin{aligned} 0 = & -R_{2j} \delta_{i1} \left. \frac{d\bar{u}_1(x_2)}{dx_2} - R_{i2} \delta_{j1} \frac{d\bar{u}_1(x_2)}{dx_2} \right|_{x_2+r_2} \\ & - [\bar{u}_1(x_2 + r_2) - \bar{u}_1(x_2)] g \frac{\partial R_{ij}}{\partial \tilde{r}_1} \\ & - \frac{1}{\rho} \left[\frac{1}{g} \frac{\partial g}{\partial \tilde{x}_i} \tilde{r}_k \frac{\partial \overline{p u_j}}{\partial \tilde{r}_k} - g \frac{\partial \overline{p u_j}}{\partial \tilde{r}_i} + g \frac{\partial \overline{u_i p}}{\partial \tilde{r}_j} \right] \\ & - \frac{1}{g} \frac{\partial g}{\partial \tilde{x}_k} \tilde{r}_l \frac{\partial R_{(ik)j}}{\partial \tilde{r}_l} + g \frac{\partial}{\partial \tilde{r}_k} [R_{(ik)j} - R_{i(jk)}] . \end{aligned} \quad (13)$$

As mentioned above, there is no hidden \mathbf{x} dependence in the correlation function and therefore all $\tilde{\mathbf{x}}$ derivatives coming from (12a) have been omitted. Obviously, equation (13) can only have a non-trivial solution, and thus be independent of \mathbf{x} , if all the coefficients have the same functional dependence on \mathbf{x} . Hence, the following set of differential equations determine the \bar{u}_1 and g dependence on \mathbf{x}

$$\frac{1}{g} \frac{\partial g}{\partial x_i} \sim g \quad \text{for } i = 1, 2, 3, \quad \frac{d\bar{u}_1(x_2)}{dx_2} \sim g \quad (14)$$

and

$$\frac{1}{g} \left. \frac{d\bar{u}_1(x_2)}{dx_2} \right|_{\mathbf{x}+\boldsymbol{\tau}} = f_1(\tilde{\boldsymbol{\tau}}) \neq f_2(\mathbf{x}), \quad \bar{u}_1(x_2 + r_2) - \bar{u}_1(x_2) = f_3(\tilde{\boldsymbol{\tau}}) \neq f_4(\mathbf{x}). \quad (15)$$

are additional consistency conditions for \bar{u}_1 and g . The last equation in (14) determines g to depend only on x_2 . Hence, the equations (14) have two independent sets of solutions given by

$$g(x_2) = \frac{1}{c_2^{(1)}(x_2 - c_1^{(1)})}, \quad \bar{u}_1(x_2) = \frac{c_3^{(1)}}{c_2^{(1)}} \ln(x_2 - c_1^{(1)}) + c_4^{(1)} \quad (16)$$

and

$$g(x_2) = c_1^{(2)}, \quad \bar{u}_1(x_2) = c_2^{(2)} c_1^{(2)} x_2 + c_3^{(2)} \quad (17)$$

where the $c_q^{(p)}$'s are integration constants or proportionality factors. Obviously, only the first set of equations correspond to a boundary layer flow because the solutions (17) define homogeneous shear turbulence which contradicts the assumption to be independent of time. Both equations (15) require $c_1^{(1)} = 0$ and $c_2^{(1)}$ can be absorbed in the correlation functions. In common notation we finally obtain

$$\bar{u}_i = u_\tau \delta_{i1} \left[\frac{1}{\kappa} \ln(x_2) + C \right] \quad (18)$$

and

$$\tilde{\boldsymbol{\tau}} = \frac{\boldsymbol{\tau}}{x_2} \quad (19)$$

where u_τ is defined as

$$u_\tau = \sqrt{\left. \frac{\nu}{\rho} \frac{d\bar{u}}{dx_2} \right|_{x_2=0}}. \quad (20)$$

Inserting (18) and (19) into equation (13) and multiplying by the von Kármán constant κ the final form of the R_{ij} -equation results:

$$\begin{aligned}
0 = & -R_{2j}^* \delta_{i1} - R_{i2}^* \delta_{j1} \frac{1}{1 + \tilde{r}_2} - \ln(1 + \tilde{r}_2) \frac{\partial R_{ij}^*}{\partial \tilde{r}_1} \\
& + \frac{\kappa}{\rho} \left[\delta_{i2} \tilde{r}_k \frac{\partial \overline{pu_j^*}}{\partial \tilde{r}_k} + \frac{\partial \overline{pu_j^*}}{\partial \tilde{r}_i} - \frac{\partial \overline{u_i p^*}}{\partial \tilde{r}_j} \right] \\
& + \kappa \left[\tilde{r}_l \frac{\partial R_{(i2)j}^*}{\partial \tilde{r}_l} + \frac{\partial}{\partial \tilde{r}_k} \left(R_{(ik)j}^* - R_{i(jk)}^* \right) \right] \quad (21)
\end{aligned}$$

where

$$R_{ij}^* = \frac{R_{ij}}{u_\tau^2}, \quad R_{(ik)j}^* = \frac{R_{(ik)j}}{u_\tau^3}, \quad R_{i(jk)}^* = \frac{R_{i(jk)}}{u_\tau^3}, \quad \overline{pu_j^*} = \frac{\overline{pu_j}}{u_\tau^3} \quad \text{and} \quad \overline{u_i p^*} = \frac{\overline{u_i p}}{u_\tau^3}. \quad (22)$$

The procedure described above can be extended to the three-point triple-correlation equation and any higher order correlation equation if an additional spatial point is introduced for each additional tensor order. As a result it is easy to verify that the whole set of equations define an *infinite* set of *linear* tensor equations but which are far too complex to be solved in general. Nevertheless, it is worthwhile to analyze some features of the solution.

In principle this infinite set of equations could be solved by the following procedure. Beginning with the two-point correlation equation, the triple correlation can be considered as an inhomogeneous part of the R_{ij} equation. Once the homogeneous solution is obtained, the inhomogeneous solution can be computed by standard methods. In the next step, the triple-correlation equation has to be tackled and its solution will be substituted in the solution for R_{ij} , and so forth for higher correlations. In each equation the von Kármán constant κ only appears as a factor of the highest order tensor and hence the final solution for R_{ij} is a power series in κ

$$R_{ij}^* = \sum_{m=0}^{\infty} a_{ij}^{(m)} \kappa^m. \quad (23)$$

$a_{ij}^{(0)}$ represents the solution of the two-point correlation equation after neglecting the triple-correlations and all higher order terms.

The structure of the formal solution in equation (23) admits the hope that a truncated series may provide some insight in the log-law statistics. Hence, in the following the triple-correlations will be neglected. Using the similarity variable in the poisson and the continuity equations, the $\overline{pu_j}$ equation (6) becomes

$$\tilde{r}_k \tilde{r}_l \frac{\partial^2 \overline{pu_j^*}}{\partial \tilde{r}_k \partial \tilde{r}_l} + \frac{\partial^2 \overline{pu_j^*}}{\partial \tilde{r}_k^2} + 2\tilde{r}_k \frac{\partial^2 \overline{pu_j^*}}{\partial \tilde{r}_k \partial \tilde{r}_2} + 2\tilde{r}_k \frac{\partial \overline{pu_j^*}}{\partial \tilde{r}_k} + 2 \frac{\partial \overline{pu_j^*}}{\partial \tilde{r}_2} = \frac{2\rho}{\kappa} \frac{\partial R_{2j}^*}{\partial \tilde{r}_1}, \quad (24)$$

the $\overline{u_i p}$ equation (7) becomes

$$\frac{\partial^2 \overline{u_i p^*}}{\partial \tilde{r}_k \partial \tilde{r}_k} = -\frac{2\rho}{\kappa} \frac{1}{1 + \tilde{r}_2} \frac{\partial R_{i2}^*}{\partial \tilde{r}_1}, \quad (25)$$

and the continuity equations (8) and (9) yield

$$\tilde{r}_k \frac{\partial R_{2j}^*}{\partial \tilde{r}_k} + \frac{\partial R_{ij}^*}{\partial \tilde{r}_i} = 0, \quad \frac{\partial R_{ij}^*}{\partial \tilde{r}_j} = 0, \quad (26)$$

$$\frac{\partial \overline{p u_j^*}}{\partial \tilde{r}_j} = 0 \quad \text{and} \quad \tilde{r}_k \frac{\partial \overline{u_2 p^*}}{\partial \tilde{r}_k} + \frac{\partial \overline{u_i p^*}}{\partial \tilde{r}_i} = 0. \quad (27)$$

The identities (10) can also be transformed in a similar manner. Introducing the transformation (19) into the equation (10a), we obtain the relation $R_{ij}(x_2, x_2 \tilde{r}) = R_{ji}(x_2(1 + \tilde{r}_2), -x_2 \tilde{r})$. Because it was previously assumed that all two-point correlation functions are solely functions of \tilde{r} , only the ratio of the first and the second parameter can appear in R_{ij} . This argumentation can be extended to the pressure velocity correlation. Thus, we finally obtain

$$R_{ij}^*(\tilde{r}) = R_{ji}^*\left(\frac{-\tilde{r}}{1 + \tilde{r}_2}\right) \quad (28)$$

and

$$\overline{u_i p^*}(\tilde{r}) = \overline{p u_i^*}\left(\frac{-\tilde{r}}{1 + \tilde{r}_2}\right). \quad (29)$$

The latter identity also holds if $\overline{u_i p^*}$ and $\overline{p u_i^*}$ are interchanged.

These two relations give valuable insight into the structure of the solution. Relation (28) connects different \tilde{r} domains to each other and provides boundary conditions in the \tilde{r}_2 direction.

One interesting feature of (28) is that it can be considered as a functional equation for each trace element. It is easy to verify that one solution, but probably not the most general solution to equation (28), is given by the following form

$$R_{[\gamma\gamma]}^*(\tilde{r}) = F_\gamma \left[\left(\ln(1 + \tilde{r}_2) \right)^2, \frac{\tilde{r}_1}{\tilde{r}_2}, \frac{\tilde{r}_3}{\tilde{r}_2} \right] \quad (30)$$

where $R_{[\gamma\gamma]}^*$ is one of the three trace elements of R_{ij}^* .

In addition if the solution for any off-diagonal R_{ij}^* element ($i \neq j$) is known, (28) provides the solution for the R_{ji}^* . A similar feature for $\overline{u_i p^*}$ and $\overline{p u_i^*}$ is given by relation (29).

If boundary conditions have to be satisfied in infinity, all correlation functions decay to zero. Therefore, any solution of equations (21) and (24)–(27) have to obey the boundary conditions

$$R_{ij}^*(\tilde{r}_k \rightarrow \pm\infty) = \overline{p u_i^*}(\tilde{r}_k \rightarrow \pm\infty) = \overline{u_i p^*}(\tilde{r}_k \rightarrow \pm\infty) = 0 \quad \text{for } k = 1, 3 \quad (31)$$

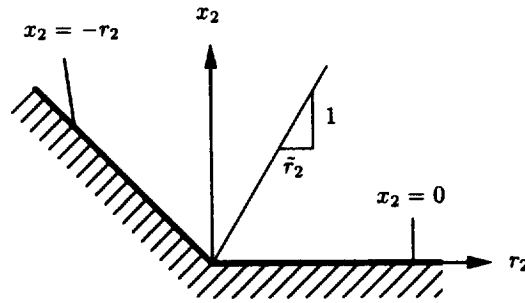

FIGURE 2. Sketch of the boundary condition in the x_2 - r_2 plane.

and

$$R_{ij}^*(\tilde{r}_2 \rightarrow \infty) = \overline{p u_i}^*(\tilde{r}_2 \rightarrow \infty) = \overline{u_i p}^*(\tilde{r}_2 \rightarrow \infty) = 0 . \quad (32)$$

To better understand the boundary conditions in the wall-normal direction, a sketch of the x_2 - r_2 plane is given in Fig. 2. Picking any value for x_2 , the negative part of r_2 can not be smaller than x_2 and hence one bound is on the line $x_2 = -r_2$. The bound for the physical coordinate is at $x_2 = 0$. Using the definition of the scaled non-dimensional coordinate (19), it is clear from Fig. 2 that \tilde{r}_2 represents the inverse of the slope given by any straight line through the origin ranging between the two latter bounds. Hence, the domain for \tilde{r}_2 is restricted to $-1 \leq \tilde{r}_2 < \infty$. Using (28) and (29) together with (32) one obtains

$$R_{ij}^*(\tilde{r}_2 = -1) = 0 \quad (33)$$

and

$$\overline{p u_i}^*(\tilde{r}_2 = -1) = \overline{u_i p}^*(\tilde{r}_2 = -1) = 0 . \quad (34)$$

Obviously, the boundary conditions are all homogeneous and one may expect the solution to be zero. In section (5) it will be discussed why the equations might have a non-trivial solution, but a rigorous proof is still outstanding. In the next section an integral relation coming from the one-point equations will be derived, which closes the missing information regarding the scaling of the two-point correlations.

4. Kolmogorov's universal range and one-point correlations

The self-similarity of the correlation functions introduced in section 3 is only valid in the limit of large Reynolds number, based on the wall distance and the friction velocity

$$Re_\tau = \frac{u_\tau x_2}{\nu} \quad (35)$$

This is also the definition of y^+ . From experiments it is known that the log region starts at about $y^+ = 40$ and extends to $y^+ = 0.2U\delta/\nu$.

The analysis in the previous chapters is inviscid, and hence is not a regular expansion in Re_τ . It is not applicable for small correlation distances, as will be explained in some detail now. An inner viscous layer in correlation space has to be introduced in order to meet the requirement that viscosity is important for the dissipation tensor ε_{ij} in the one-point limit.

Comparing the two-point correlation equation (5) in its most general form to the inviscid version in the log-layer (21), no viscous term has been retained. In contrast to that, the Reynolds stress transport equation in the log-layer

$$-[\overline{u_i u_2} \delta_{j1} + \overline{u_2 u_j} \delta_{i1}] \frac{u_\tau}{\kappa x_2} + \Phi_{ij} - \varepsilon_{ij} = 0 \quad (36)$$

contains the viscosity ν in the dissipation tensor, defined by

$$\varepsilon_{ij} = 2\nu \overline{\frac{\partial u_i}{\partial x_k} \frac{\partial u_j}{\partial x_k}} = 2\nu \lim_{r=0} \left[\frac{\partial^2 R_{ij}}{\partial x_k \partial r_k} - \frac{\partial^2 R_{ij}}{\partial r_k \partial r_k} \right] \quad (37)$$

and the pressure-strain tensor is defined by

$$\Phi_{ij} = \frac{p}{\rho} \overline{\left[\frac{\partial u_j}{\partial x_i} + \frac{\partial u_i}{\partial x_j} \right]} = \lim_{r=0} \left[\frac{\partial \overline{p u_j}}{\partial r_i} + \frac{\partial \overline{u_i p}}{\partial x_j} - \frac{\partial \overline{u_i p}}{\partial r_j} \right] . \quad (38)$$

The contraction of equation (36) together with $\overline{u_1 u_2} = -u_\tau^2$ determines the scalar dissipation

$$\varepsilon = \frac{\varepsilon_{kk}}{2} = \frac{u_\tau^3}{\kappa x_2} . \quad (39)$$

As mentioned above we find from equation (36) that the asymptotic arguments we have used so far are not valid for correlation distances on the order of the Kolmogorov length scale l_η . The Kolmogorov length and velocity scale are given by

$$l_\eta = \left(\frac{\nu^3}{\varepsilon} \right)^{\frac{1}{4}} = x_2 Re_\tau^{-\frac{3}{4}} \kappa^{\frac{1}{4}} \quad \text{and} \quad u_\eta = (\nu \varepsilon)^{\frac{1}{4}} = u_\tau Re_\tau^{-\frac{1}{4}} \kappa^{-\frac{1}{4}} . \quad (40)$$

The only scaling of the independent variables with which the correct balance can be achieved in the two-point correlation equation is given by

$$\boldsymbol{\xi} = \frac{\mathbf{r}}{l_\eta} = Re_\tau^{\frac{3}{4}} \kappa^{-\frac{1}{4}} \frac{\mathbf{r}}{x_2} . \quad (41)$$

In line of Kolmogorov's arguments, the scaling of the dependent variables must be

$$R_{ij} = u_\tau^2 \overline{u_i u_j^*} - u_\eta^2 \left[B_{ij}^{(0)}(\boldsymbol{\xi}) + O\left(Re_\tau^{-\frac{1}{4}}\right) \right] ,$$

$$R_{(ik)j} = u_\eta^3 \left[D_{(ik)j}^{(0)}(\boldsymbol{\xi}) + O\left(Re_\tau^{-\frac{1}{4}}\right) \right] ,$$

$$\begin{aligned}
R_{i(jk)} &= u_\eta^3 \left[D_{i(jk)}^{(0)}(\xi) + O\left(Re_\tau^{-\frac{1}{4}}\right) \right] , \\
\overline{p u_j} &= \rho u_\eta^3 \left[M_j^{(0)}(\xi) + O\left(Re_\tau^{-\frac{1}{4}}\right) \right] , \\
\overline{u_j p} &= \rho u_\eta^3 \left[N_i^{(0)}(\xi) + O\left(Re_\tau^{-\frac{1}{4}}\right) \right] .
\end{aligned} \tag{42}$$

Putting (41) and (42) into (5), (6) and (7) the leading order terms in each equation are given by

$$-\delta_{i1} \overline{u_2 u_j^*} - \delta_{j1} \overline{u_i u_2^*} + \frac{\partial M_j^{(0)}}{\partial \xi_i} - \frac{\partial N_i^{(0)}}{\partial \xi_j} - 2 \frac{\partial^2 B_{ij}^{(0)}}{\partial \xi_k \partial \xi_k} + \frac{\partial D_{(ik)j}^{(0)}}{\partial \xi_k} - \frac{\partial D_{i(jk)}^{(0)}}{\partial \xi_k} , \tag{43}$$

$$\frac{\partial^2 M_j^{(0)}}{\partial \xi_k \partial \xi_k} = - \frac{\partial^2 D_{(kl)j}^{(0)}}{\partial \xi_k \partial \xi_l} \tag{44}$$

and

$$\frac{\partial^2 N_i^{(0)}}{\partial \xi_k \partial \xi_k} = - \frac{\partial^2 D_{i(kl)}^{(0)}}{\partial \xi_k \partial \xi_l} . \tag{45}$$

In order to obtain a uniform solution there must be an overlapping region that matches the inner and the outer solution together. From (42a) we see that the limit $\xi \rightarrow \infty$ in the inner layer of the two-point correlation converges to the Reynolds stress tensor and the same must be valid for a solution of the equations (21) and (24)–(29) in the outer layer for the limit $\tilde{r} \rightarrow 0$. Using the same limits for both regions in the triple- and the pressure-velocity correlations, they both drop to zero as they should do. As a result, the matching between the inertial subrange and obviously specifies the outer solution R_{ij}^* at $r = 0$ to be $\overline{u_i u_j}$, but the actual numerical value of Reynolds stress tensor is still unknown.

Note, that the equation corresponding to (43) in Mellor's paper (1972) (his equation (59)) has a serious error. It does not have the production terms which, of course, are responsible for the energy transfer rate.

As mentioned above the inner layer does not determine the absolute value of the Reynolds stress tensor because the triple correlations can not be neglected in (43)–(45). Thus an additional assumption is needed to determine the values of $\overline{u_i u_j}$.

In Kolmogorov's original hypotheses it was suggested that in the limit of large Reynolds number the dissipation will be isotropic. Saddoughi's (1994) very high Reynolds number experiment of a turbulent boundary layer in a wind tunnel supports this idea of isotropy. Hence, we take

$$\varepsilon_{ij} = \frac{2}{3} \delta_{ij} \varepsilon . \tag{46}$$

Using this, the three trace elements of Φ_{ij} can be obtained from the Reynolds Stress tensor equation which in non-dimensional form can be written as

$$-[\overline{u_i u_2^*} \delta_{j1} + \overline{u_2 u_j^*} \delta_{i1}] + \Phi_{ij}^* - \frac{2}{3} \delta_{ij} = 0 \quad \text{with} \quad \Phi_{ij}^* = \Phi_{ij} \frac{\kappa x_2}{u_\tau^3} \quad (47)$$

or in component notation

$$\Phi_{11}^* = -\frac{4}{3}, \quad \Phi_{22}^* = \frac{2}{3}, \quad \Phi_{33}^* = \frac{2}{3}. \quad (48)$$

Note, that the latter result for the pressure-strain correlation holds no matter what is assumed for the triple-correlations. As a result, all high Reynolds number second-moment closure models should be consistent with this result. In most second moment models this could only be ensured by adding wall reflection terms to the pressure-strain model.

Because the system (21) and (24)–(29) has homogeneous boundary conditions on all boundaries, there is nothing that specifies the amplitude of R_{ij}^* , or the value of $\overline{u_i u_j^*}$ as mentioned above. In fact, this would also be true if higher correlation functions would have been taken into account. The definition (38) together with the result (48) can be used to calculate the values for the Reynolds stress tensor.

The term on the right-hand side of (38) can be rewritten as an integral of the two-point correlation and some boundary integrals. This was necessary because the limit $r \rightarrow 0$ has to be evaluated within the dissipation range where not enough is known about the two-point velocity-pressure correlation. It can be found that the dissipation range, which is of the order of l_η , makes a higher order contribution to the above mentioned integral in the limit of large Reynolds number and thus can be neglected. After neglecting the triple-correlations we find

$$\Phi^* = -\frac{1}{2\pi} \int_{\tilde{V}} \frac{1}{1 + \tilde{r}_2} \left[\left(\delta_{j2} \frac{\partial R_{i2}^*}{\partial \tilde{r}_1} + \tilde{r}_i \frac{\partial^2 R_{il}^*}{\partial \tilde{r}_i \partial \tilde{r}_1} \right) + \frac{\partial^2 R_{i2}^*}{\partial \tilde{r}_j \partial \tilde{r}_1} \right] \frac{dV(\tilde{\mathbf{r}})}{|\tilde{\mathbf{r}}|} + (i \leftrightarrow j) \quad (49)$$

where $(i \leftrightarrow j)$ abbreviates the addition of the previous term with indices interchanged. No boundary integral has to be kept due to the homogeneous boundary conditions for all variables. Once a solution to the equations (21) and (24)–(27) are computed the scaling of the two-point correlations can be calculated by equating (48) and (49). Using this, the value for $\overline{u_i u_j^*}$ can be taken from R_{ij}^* at $r = 0$ as has been proven by the matching between the Kolmogorov universal range and the outer inviscid solution.

5. Future plans

There are basically two outstanding problems within the whole approach of RDT in the log-layer. The first one is the fact that it has to be proven that the system (21), (24)–(29) has a non-zero solution even though all boundary conditions are homogeneous. A strong hint towards this character of the equation is gained by the analysis of the discretised set of equations which, of course, is linear. To see why the equations may have a non-zero solution, a result from linear algebra may

be recalled. If in a linear system of the form $\mathbf{Ax} = 0$ the matrix \mathbf{A} has the rank ζ and $\zeta < n$ where n is the number of equations, then the system has nontrivial solutions. In this particular case considering the discretised equations (21), (24)–(27), \mathbf{A} is a quadratic matrix and its rank can only be smaller than n if there is some redundancy in the equations. In fact, this redundancy is due to the identities (28) and (29). Even though the structure of the discretised system provides some information, the proof of a corresponding feature in the differential equations is still outstanding. Once the previous problem is solved, a numerical algorithm has to be coded to solve the discretised equations (21) and (24)–(29) because it is very unlikely that an analytical solution can be found. In the next step of post-processing the numerical results, the ability of the asymptotic limits used in the RDT of the log-layer has to be revised and if necessary enhanced by including higher correlations in the analysis. Finally, the results of the theory will be compared with DNS data from the turbulent channel flow (Kim *et al.* 1987).

Acknowledgment

The author is sincerely grateful to William C. Reynolds and Paul A. Durbin for many valuable discussions and critical comments during the development of the work. The work was in part supported by the Deutsche Forschungsgemeinschaft.

REFERENCES

- VON KÁRMÁN, TH. 1930 Mechanische Ähnlichkeit und Turbulenz. *Nachr. Ges. Wiss. Goettingen.* **68**.
- VON KÁRMÁN, TH. 1930 Mechanische Ähnlichkeit und Turbulenz. *Proc. 3rd Int. Congr. Appl. Mech., Stockholm.* **1**.
- KASSINOS, S. C. & REYNOLDS, W. C. 1994 A structure-based model for rapid distortion of homogeneous turbulence. *Thermosciences Report No. TF-61*.
- KIM, J., MOIN, P. & MOSER, R. D. 1987 Turbulence statistics in fully developed channel flow at low Reynolds number. *J. Fluid Mech.* **177**, 133–166.
- MELLOR, G. L. 1972 The large Reynolds number asymptotic theory of turbulent boundary layers. *Int. J. Engng Sci.* **10**, 851–873.
- MILLIKAN, C. B. 1939 A critical discussion of turbulent flows in channels and circular tubes. *Proc. 5th Int. Congr. Appl. Mech., Cambridge*.
- ROTTA, J. C. 1972 *Turbulente Strömungen*. Teubner Verlag Stuttgart.
- SADDOUGHI, S. G. & VEERAVALLI, S. V. 1994 Local isotropy in turbulent boundary layers at high Reynolds number. *J. Fluid Mech.* **268**, 333–372.