

SI-35

44760

## A PC BASED TIME DOMAIN REFLECTOMETER FOR SPACE STATION CABLE FAULT ISOLATION

Michael Pham and Marty McClean  
Propulsion and Power Division  
NASA/JSC Houston, Texas

Sabbir Hossain, Peter Vo and Ken Kouns  
Propulsion and Power Department  
Lockheed Engineering and Sciences Co.  
Houston, Texas

### **KEYWORDS**

Time Domain Reflectometer, Fault Detection and Isolation, Space Station Cable

### **ABSTRACT**

Significant problems are faced by astronauts on orbit in the Space Station when trying to locate electrical faults in multi-segment avionics and communication cables. These problems necessitate the development of an automated portable device that will detect and locate cable faults using the pulse-echo technique known as Time Domain Reflectometry. A breadboard time domain reflectometer (TDR) circuit board was designed and developed at the NASA-JSC. The TDR board works in conjunction with a GRiD lap-top computer to automate the fault detection and isolation process. A software program was written to automatically display the nature and location of any possible faults. The breadboard system can isolate open circuit and short circuit faults within two feet in a typical space station cable configuration. Follow-on efforts planned for 1994 will produce a compact, portable prototype Space Station TDR capable of automated switching in multi-conductor cables for high fidelity evaluation. This device has many possible commercial applications, including commercial and military aircraft avionics, cable TV, telephone, communication, information and computer network systems.

This paper describes the principle of time domain reflectometry and the methodology for on-orbit avionics utility distribution system repair, utilizing the newly developed device called the Space Station Time Domain Reflectometer (SSTDR).

### **INTRODUCTION**

The utility distribution system for the Space Station delivers essential fluid and avionics utilities to all system elements such as the nodes, habitation and laboratory module, and many of Freedom's external orbital replacement units (ORU's). The utilities are distributed with the aid of two integrated fluid and electrical utility trays per segment of the Space Station connected together at termination points of trays. These trays provide environmental protection to the lines from contamination and damage from micrometeoroid/orbital debris (MMOD), atomic oxygen (AO), and ultraviolet (UV) rays. By design, the utility avionics line connections are to be performed by EVA using EVA-compatible Zero-G electrical connectors. Maintainability and reparability of these utility and avionics lines are major concerns.

Design requirements were identified early in the development of the Space Station. For utility distribution, the design must meet the following requirements:

- minimize on-orbit installation and maintenance time
- allow for EVA assembly while meeting EVA time constraints
- provide accessibility for on-orbit repair.

In general, the electrical cable on-orbit may fail in two different ways; (1) a short circuit caused by damaged wire insulation, bent connector pins and metallic particles in connectors, or (2) an open circuit caused by a broken wire due to EVA damage or meteoroid impact or an open connector.

In the event of such a cable failure, the space station contractor proposes to use the following EVA maintenance scenarios:

Avionics systems that have suffered damage will be removed end-to-end from the utility tray and a replacement line will be installed end-to-end. The sections of "the remove and replace units" of one truss segment vary in length from 23 to 45 ft. Avionics line maintenance is considered as a one crew member task. The EVA crew-member would perform the steps shown in the timeline of Table 1. The timeline shows that the remove and replace scenario of one avionics line segment is about 41 minutes. And this will be repeated until the exact failed segment is found and replaced. Some systems have as many as 6 segments to be replaced. This remove and replace approach would be EVA intensive and has extremely high cost for logistics of all avionics lines segments.

Table 1  
Timeline for avionics line removal and replacement task

No.	Crew	Task description	Assumptions	Time (Min-sec)
1	EV1	Open tray cover of segment end exposing Segment -to-segment connection of avionics lines	In position on PWP Secure tray cover in open position	1:00
2	EV1	Disconnect 0-g connector of one end of failed line		0:30
3	EV1	Translate along length of segment tray, opening tray covers and releasing clamps on failed line.	Translate via SSRMS; Loosen lines from clamps	5:00
4	EV1	Disconnect 0-g connector of second end of failed line		0:30
5	EV1	Remove failed line		10:00
6	EV1	Connect 0-g connector of replacement line		0:30
7	EV1	Translate along length of segment tray, installing line in tray, closing line clamps, and closing tray covers.		15:00
8	EV1	Connect 0-g connector of second end of replacement line		0:30
9	EV1	Close tray covert		
Estimated Task Time with 20% overhead				41:24

NASA/JSC has developed an alternate technique to pin-point the location of the fault. It is based on the time domain reflectometer (TDR) concept. The TDR technology has been around for years. Several companies such as Tektronix, Biddle Instruments, Hewlett Packard, Cabletron, Anristu offer such devices. But they are industrial or commercial units, and none would meet the requirements of the space station environment. Hence, a prototype TDR system was developed at JSC, referred in this paper as the Space Station Time Domain Reflectometer (SSTDR), that is compact, portable for astronaut usage and has the ability to pin-point faults in a multi-conductors cable.

Unlike any TDR device on the market, the SSTDR is integrated with a lap-top computer. The computer in the SSTDR system is used to store cable and connector data, and to interpret the TDR waveform. Because, the software which is used for controlling the operation of the TDR and manipulation of data, is stored on the computer hard disk, the future program changes can be made with little or no hardware change. Thus program improvements and program modifications to fit specific type cable or cable configuration needs may be implemented easily. The biggest advantage of a PC based TDR is that the base line waveform and configuration of a cable can be stored on the computer hard disk or optical disk which can be retrieved for comparison with the real time data of the cable under test.

The SSTDR system also contains a switch matrix so that any set of two conductor cables can be selected from a bundle of cable under computer command. The ease of use, the flexibility, the custom programmability, and the ability to locate electrical faults multi-conductor cable in a faster and more efficient manner, make the SSTDR a unique instrument for cable fault detection and location.

This paper describes in detail the Space Station Time Domain Reflectometer. It also describes the implementation and capabilities of the system and gives insight into potential growth features.

## **SSTDR PRINCIPLES OF OPERATION**

A time domain reflector works on the same principles as radar. Ultra-fast rise time voltage steps ( $V_i$ ) are sent down the cable under test. The step signal travels along the cable until it finds an impedance mismatch causes a reflection. The reflection returns to the cable end and is received by a sampler circuit (Figure 1).

If the reflection is caused by a short or an open in the cable, a voltage step is reflected back. The reflected voltage ( $V_r$ ) is superimposed on the advancing initial step and will appear as a step-up or step-down transition on the display, depending on whether it is reflected in-phase or out-of-phase with respect to the initial step. The reflected voltage is step-up for an open circuit and step-down for a short circuit fault.

The position of the mismatch will appear at a point on the reflection-time data directly proportional to the linear position of the cause. The distance of the mismatch, the fault, is derived from measuring the time lapse, in nanoseconds, between the sending of the step and the reception of its reflection. Because the approximate velocities of propagation of such step functions in cables of different construction are known, the distance to the fault in feet is the product of the measured time lapse and the known velocity of propagation in feet per nanosecond. Because the pulse travels "there and back", it is convenient to use half the value of the velocity of propagation.

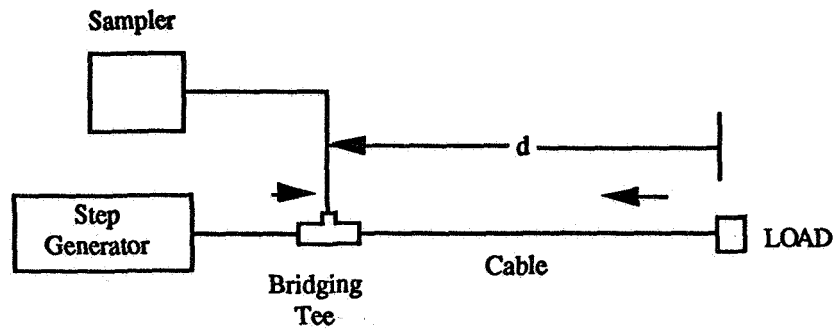

(a) A basic TDR Set-up

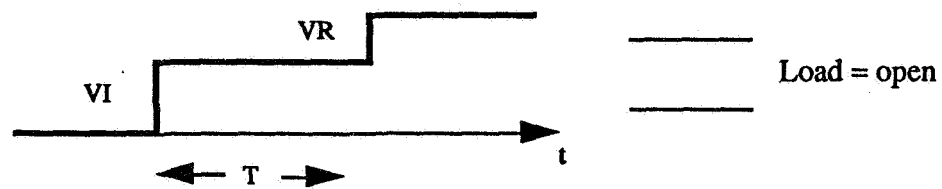

(b) Open Circuit: Total reflection is in-phase at the load

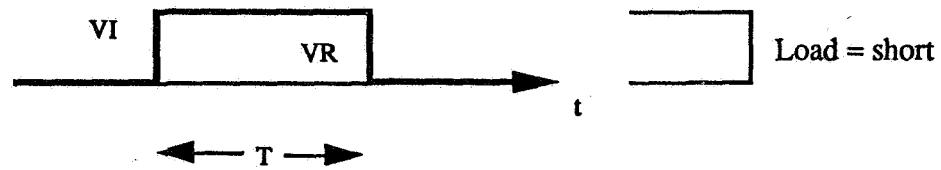

(c) Short Circuit: Total reflection is out-of-phase at the load

Figure 1 (a)-(c): Principle of Fault Location using TDR.

## SSTDR HARDWARE

The SSTDR design is the only time domain reflectometer system that uses a portable GRiD lap-top computer integrated with the TDR circuit. The GRiD computer contains the high level software which controls the operation of the TDR, the data base for the cable under test, and the base line cable signature. The TDR circuit board consists of a microcontroller, a pulse generator, a timebase circuit, a sampling circuit and a switching circuit. A block diagram of the hardware used in the pre-prototype SSTDR is shown in Figure 2.

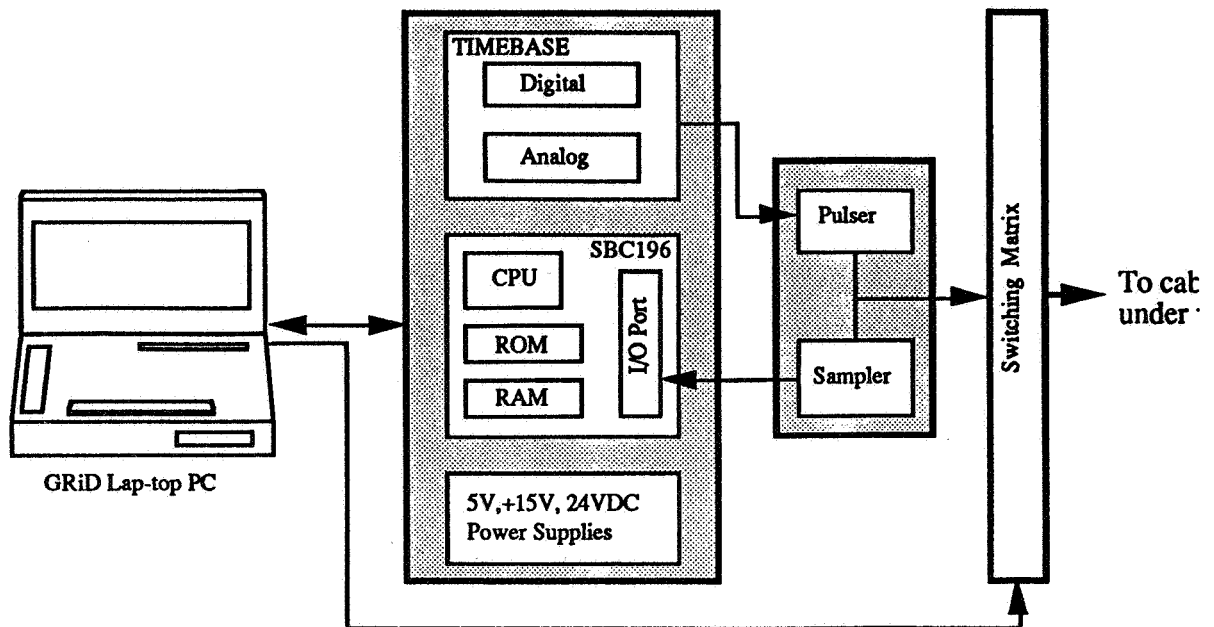

Figure 2: A Block diagram of SSTDR system.

The pulse generator produces a 25 microsecond, 600 milivolt pulse every 250 microseconds. The pulse rise time of 1 nanosecond gives a fault location resolution of approximately 1/3 of a foot.

The timebase circuit generates precisely timed strobes to the pulse driver and sampler circuit. The digital portion of the timebase contains a 20 MHz precision clock and a programmable digital counter to produce a pulse every 250 microseconds. The output of the digital counter is used to trigger a delay counter which provides 50 nanosecond resolution to the sampler time delay. The end of the delay counter signal is used to generate a timebase interrupt request to the processor to inform that a sample is being taken. The output of the delay counter is also provided to an analog ramp circuit for further control delay. The voltage of the ramp circuit is compared to the output of a digital to analog converter such that, every time the comparator produces a sampling pulse, it is delayed by 1 nanosecond from the previous pulse. Thus, the TDR waveform can be broken down into discrete samples, and each advanced in time by 1 nanosecond.

The sampling pulse activates the sample/hold circuit. The signal from the sample hold circuit is fed to the 10 bit A/D converter of the Intel 80C196KC microcontroller. The A/D conversion is activated by an interrupt request signal from the digital timebase delay circuit. The single board microcontroller operates at 16 MHz. A 128K EPROM is used to store the system and application software and a 64K RAM to store temporary data and to perform all necessary functions of the TDR board. The communication to the host computer (GRiD) is done via a RS-232 port.

The host computer is a 386SL, 25MHz, lap-top system manufactured by GRiD Inc. The software for data manipulation, TDR control, and graphic display is resident on the hard disk.

A computer controlled switching circuit is used to select a particular set of wires from a cable bundle. The operator can select any pair of cables by entering appropriate connector pin numbers.

## **SSTDR SOFTWARE**

The SSTDR software consists of two separate components - the software resident in the TDR board microcontroller and the other in the GRiD computer. The software in the TDR board is written in FORTH language and is primarily used to control the timing function of the pulse generation and sampling circuit, data acquisition and for temporary storage of the waveform data (Figure 3).

The host software resident in the GRiD computer is written in ADA language. It stores the data, processes it and displays the wave form. Besides data manipulation, a graphical user interface was developed to interface with the operator. The operator can select the mode of operation, cable configuration, type of connector and particular set of cables to be tested. The flow chart for operation sequence of the SSTDR is given in the appendix.

The SSTDR has two operation modes: manual mode and automated mode. The manual mode enables the user to select any particular pair of wires and analyze the cable. In the manual mode, the SSTDR can also be used as a general purpose cable analyzer. In the automated mode, however, the operator can test a specific space station cable configuration. In this mode, the SSTDR, under software control, tests all individual cables in sequence. By using a switching matrix, the SSTDR sequentially switches through all conductors in the cable system and tests them.

In both of these modes, the SSTDR can automatically detect and locate any fault if the data base is resident in memory for a particular cable under test. The data bases consists of nominal information about the cable under test and acceptable tolerance windows for impedances of these cable paths. The data base may also incorporate a base line waveform of a fault-free cable which can be used for comparison with the waveform from a cable under test to perform fault diagnosis.

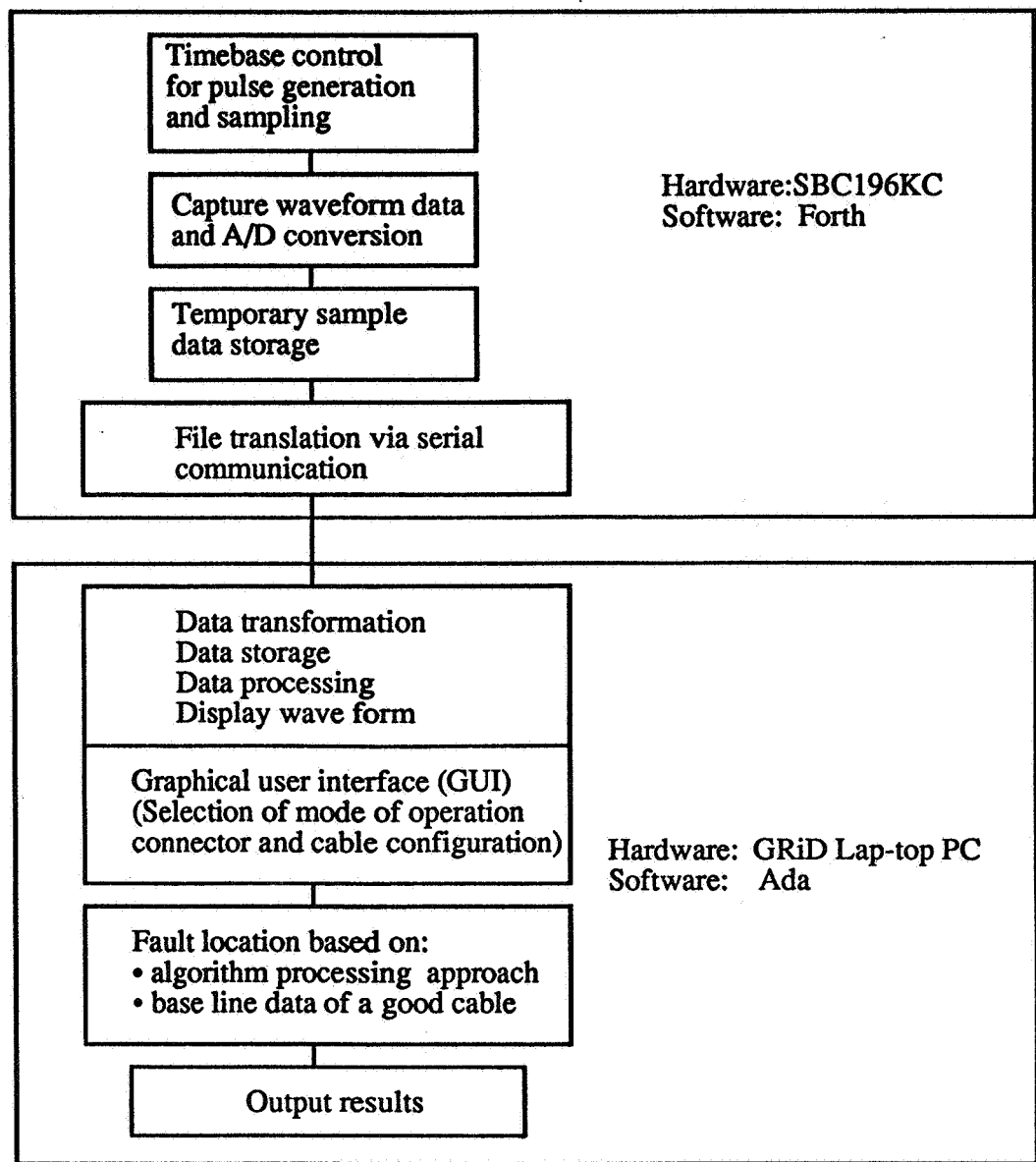
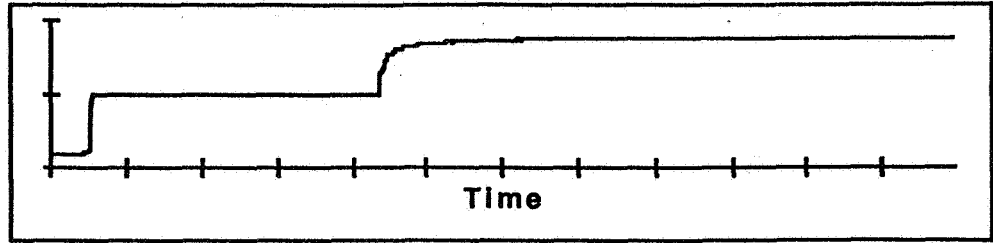

Figure 3: General system software structure.

## **LABORATORY TEST RESULTS**

During the course the SSTDR development, cables with known fault locations were tested with a prototype unit and both hardware and software were verified for their accuracy in estimating the location of the fault. Figure 4 (a)-(3) shows some of the results obtained during our test run. The test results show that a typical open or short faults can be located within a couple of feet.



(a) Case 1: Open circuit fault.

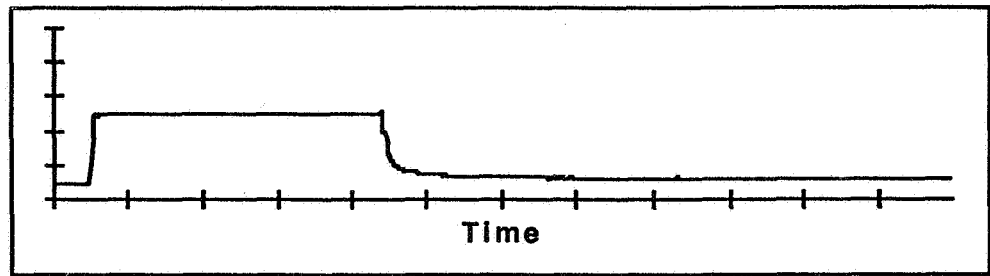

(b) Case 2: Short circuit fault.

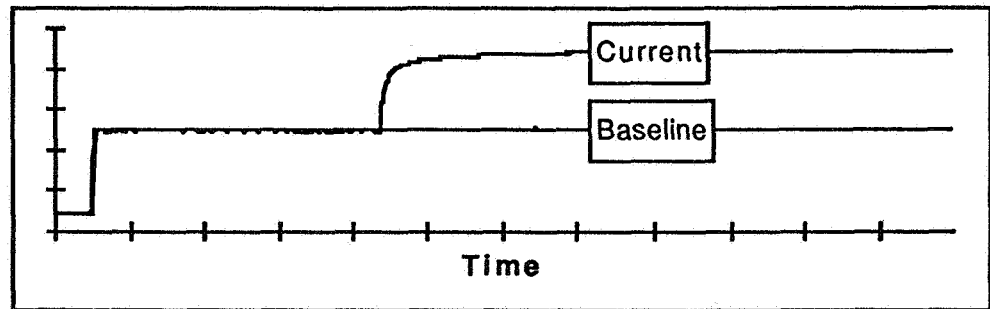

(c) Current waveform superimposed on baseline showing an open circuit fault.

Figure 4(a)-(c): Examples of waveforms obtained in the laboratory tests.



## **CONCLUSION**

Time Domain Reflectometry can be successfully applied to detection and location of faults in a multi-conductor cable system. The PC based SSTDR unit can successfully locate faults to within a couple of feet. The advantage of a PC based system that any future enhancement of the software can be easily installed in the system. The custom feature of this system lends itself to many commercial and diversified applications. including commercial and military aircraft avionics, cable TV, telephone, communication, information and computer network systems.

## **REFERENCES**

Clegg, B. and Lord, N.G.: "Modern cable-fault-location methods," Proc. IEE, Vol. 122, No. 4, April, 1975.

Scherer, R., Ray, R. and Trush V.: "A Portable Scalar Network Analyzer for the Flight Environment," Application Notes, Lockheed Sanders, Inc.

Kuan, K.K. and Warwick, K.: "Real-time expert system for fault location on high voltage underground distribution cables," Proc. IEE, Vol. 139, No. 3, May 1992.