

NASA Technical Memorandum 110379

USAATCOM Technical Report 96-A-004

Full-Scale S-76 Rotor Performance and Loads at Low Speeds in the NASA Ames 80- by 120-Foot Wind Tunnel

Volume 1

Patrick M. Shinoda

April 1996



National Aeronautics and
Space Administration



US Army
Aviation and Troop Command

Full-Scale S-76 Rotor Performance and Loads at Low Speeds in the NASA Ames 80- by 120-Foot Wind Tunnel

Volume 1

*Patrick M. Shinoda, Aeroflightdynamics Directorate, U.S. Army Aviation and Troop Command,
Ames Research Center, Moffett Field, California*

April 1996



National Aeronautics and
Space Administration

Ames Research Center
Moffett Field, CA 94035-1000



US Army
Aviation and Troop Command

Aeroflightdynamics Directorate
Moffett Field, CA 94035-1000

Nomenclature

A	rotor disk area, πR^2 , ft ²	PM	balance pitching moment, balance moment center, positive nose up, ft-lb
ALFS,U , α_s	rotor shaft angle, positive aft of vertical, deg	QPSF	free stream dynamic pressure, lb/ft ²
AF	balance axial force, balance moment center, positive aft, lb	R	rotor radius, ft
b	number of rotor blades	RHO, ρ	free stream air density, slugs /ft ³
c	mean blade airfoil chord length, ft	RM	balance rolling moment, balance moment center, positive right wing down, ft-lb
CLRH/S	rotor wind-axis lift coefficient divided by rotor solidity, positive up, $LIFTH,C / \rho(\Omega R)^2 S_R$	RPM	rotor rotational speed, rev/min
CP	rotor power coefficient, $POW/A\rho(\Omega R)^3$	SF	balance side force, balance moment center, positive starboard, lb
CP/S	rotor power coefficient divided by rotor solidity, $POW/\rho(\Omega R)^3 S_R$	S _R	rotor blade area, bcR, ft ²
C _S	speed of sound, ft/s	THRUST	rotor thrust, perpendicular to tip-path-plane, positive up, lb
CTH, C _T	rotor thrust coefficient, perpendicular to tip-path-plane, positive up, $THRUST/A\rho(\Omega R)^2$	TORQ,C, TQ	flexcoupling or rotor shaft torque, ft-lb
CTH/S, C _T /σ	rotor thrust coefficient divided by rotor solidity, positive up, $THRUST/\rho(\Omega R)^2 S_R$	V	free stream velocity, ft/s
CXRH/S	rotor wind-axis propulsive coefficient divided by rotor solidity, positive forward, $-DRAGH,C / \rho(\Omega R)^2 S_R$	VKTS	free stream velocity, kt
DRAGH,C	rotor wind-axis drag, positive downstream, lb	V/OR, μ	advance ratio, V/ΩR
FMERIT, F _M	Figure of Merit, $CTH^{3/2}/CP*(2)^{1/2}$	X	parameter resultant value in engineering units
LIFTH,C	rotor wind-axis lift, positive up, lb	X ₀	parameter offset value in engineering units
MTIP	rotor tip Mach number, $\Omega R/C_S$	X _{nc}	parameter cosine coefficient of the nth harmonic
n	nth harmonic	X _{ns}	parameter sine coefficient of the nth harmonic
NF	balance normal force, balance moment center, positive up, lb.	YAW	model yaw angle, clockwise relative to tunnel centerline, deg
OMEG*R	rotor tip speed, ΩR, ft/sec	Σ	summation
POW	rotor shaft power, TORQ,C * Ω, ft-lb/s	σ	rotor solidity, bc/πR
		Ω	rotor rotational speed, rad/s
		ψ	blade azimuthal angle, deg

Full-Scale S-76 Rotor Performance and Loads at Low Speeds in the NASA Ames 80- By 120- Foot Wind Tunnel

PATRICK M. SHINODA

*Aeroflightdynamics Directorate
Aviation Research, Development and Engineering Center
U.S. Army Aviation and Troop Command*

Ames Research Center

Summary

A full-scale helicopter rotor test was conducted in the NASA Ames 80- by 120-Foot Wind Tunnel with a four-bladed S-76 rotor system. Rotor performance and loads data were obtained over a wide range of rotor shaft angles-of-attack and thrust conditions at tunnel speeds ranging from 0 to 100 kt. The primary objectives of this test were (1) to acquire forward flight rotor performance and loads data for comparison with analytical results; (2) to acquire S-76 forward flight rotor performance data in the 80- by 120-Foot Wind Tunnel to compare with existing full-scale 40- by 80-Foot Wind Tunnel test data that were acquired in 1977; (3) to evaluate the acoustic capability of the 80- by 120-Foot Wind Tunnel for acquiring blade vortex interaction (BVI) noise in the low speed range and compare BVI noise with in-flight test data; and (4) to evaluate the capability of the 80- by 120-Foot Wind Tunnel test section as a hover facility. The secondary objectives were (1) to evaluate rotor inflow and wake effects (variations in tunnel speed, shaft angle, and thrust condition) on wind tunnel test section wall and floor pressures; (2) to establish the criteria for the definition of flow breakdown (condition where wall corrections are no longer valid) for this size rotor and wind tunnel cross-sectional area; and (3) to evaluate the wide-field shadow-graph technique for visualizing full-scale rotor wakes. This data base of rotor performance and loads can be used for analytical and experimental comparison studies for full-scale, four-bladed, fully articulated rotor systems. Rotor performance and structural loads data are presented in this report.

Introduction

Wind tunnel testing has been extensively used in the development and improvement of rotorcraft designs, in addition to providing a data base for refinement of theoretical predictions. However, no rotor test (flight tests, small-scale rotor wind tunnel tests, and specifically full-

scale rotor wind tunnel tests) has provided the necessary data in the low speed flight regime (below 60 kt) to validate prediction codes.

The Sikorsky Aircraft S-76 is one of the more thoroughly tested rotor systems, having undergone small-scale and full-scale wind tunnel testing in addition to flight testing. A full-scale test of the S-76 rotor system in the NASA Ames 40- by 80-Foot Wind Tunnel was performed and documented during the developmental phase of the rotor system (ref. 1). There also have been small-scale forward flight wind tunnel data and flight test data acquired by Sikorsky, along with isolated rotor full-scale hover data acquired with this rotor system at the Sikorsky Whirlstand Hover Facility and NASA Ames 40- by 80-Foot Wind Tunnel (ref. 2). In all these tests, however, no data were acquired in the speed range between zero and 60 kt.

To expand the existing S-76 data base and to investigate rotor performance and loads in the low speed (0 - 60 kt) flight regime, a full-scale S-76 rotor test was conducted at the NASA Ames 80- by 120-Foot Wind Tunnel. This wind tunnel test established a data base of rotor performance and loads for the 0 - 100 kt velocity range at various shaft angles and thrust conditions.

The primary objectives of this test were (1) to acquire forward flight rotor performance data for comparison with analytical results (ref. 3); (2) to acquire S-76 forward flight rotor performance data in the 80- by 120-Foot Wind Tunnel to compare with existing (ref. 1) and future 40- by 80-Foot Wind Tunnel data to evaluate differences or similarities between the two full-scale facilities (ref.3); (3) to evaluate the acoustic capability of the 80- by 120-Foot Wind Tunnel for acquiring blade vortex interaction (BVI) noise in the low speed range and compare BVI noise with in-flight test data (ref. 4); and (4) to evaluate the capability of the 80- by 120-Foot Wind Tunnel test section as a hover facility (ref. 3). The secondary objectives were (1) to evaluate rotor inflow and wake effects (variations in tunnel speed, shaft angle, and rotor thrust)

on wind tunnel test section wall and floor pressures (ref. 5); and (2) to establish the criteria for the definition of flow breakdown (point where wall corrections are no longer valid) for this size rotor and wind tunnel cross-sectional area (ref. 5); (3) to evaluate the wide-field shadowgraph technique for visualizing full-scale rotor wakes (ref. 6).

This report documents the test program and presents the rotor performance and loads data for selected test conditions. The rotor, test facility, rotor test stand, instrumentation, data reduction, and test procedures are described. The data from the test are presented in tables and plots. Hover performance data are documented in Appendix A. Forward flight rotor performance data are presented in Appendix B. Forward flight rotor blade structural loads are presented in Appendices C and D.

Description of the Experiment

NASA Ames 80- by 120-Foot Wind Tunnel

The 80- by 120-Foot Wind Tunnel is part of the National Full-Scale Aerodynamics Complex (NFAC) located at the NASA Ames Research Center. The tunnel has an open circuit with a closed, rectangular test section. The maximum test section flow speed is approximately 100 kt. Figure 1 shows a schematic of the wind tunnel circuit. The 80- by 120-Foot Wind Tunnel shares a portion of the flow circuit with the 40- by 80-Foot Wind Tunnel; both tunnels share a single drive system. The drive system consists of six fans rated at 135,000 maximum combined horsepower (101 MW). When operating in the 80- by 120-Foot Wind Tunnel mode, a system of vanes and louvers are positioned so that the 40- by 80-Foot Wind Tunnel circuit is closed off and the 80 x 120 leg forms a through-flow wind tunnel (fig. 1). The drive fans pull outside air in through the 80- by 120-Foot Wind Tunnel inlet and exhaust the air back to the atmosphere through louvers in the tunnel wall downstream of the tunnel fan drive system.

The test section is 80-ft high, 120-ft wide, and 193-ft long. The east wall of the test section has two doors that provide an access opening of approximately 80 ft in height by 120-ft in width. This opening provides room for the tunnel crane to move into the test section for installation of wind tunnel models.

General Test Hardware

The experiment was conducted in the 80- by 120-Foot Wind Tunnel using a production Sikorsky Aircraft S-76 rotor system. The rotor was mounted on NASA's modified Rotor Test Apparatus (RTA). Figure 2 shows

the model installed in the wind tunnel. The Sikorsky Aircraft S-76 rotor system is four-bladed with coincident flap and lag articulation provided at the blade root by elastomeric bearings. Blade pitch is also permitted by the same bearing through the rotor spindle. Table 1 lists the S-76 main rotor parameters. The rotor system, including the hub, spindles, blades, and swashplate, is identical to the production model. Reference 1 provides details on the spanwise distributions of the blade properties, blade airfoil and planform description, airfoil contours, and two dimensional airfoil characteristics.

The RTA is a special-purpose test stand for operating helicopter rotors in the NFAC. The test stand was originally built in the mid-1970's. The RTA houses two-electric drive motors (1500 HP each), a right-angle transmission, a new flexcoupling with a 36,000 ft-lb rotor torque capability and a new rotor balance with 22,000 lb thrust capability (installed in 1991) along with a primary and dynamic control system. The primary control system consists of three electro-hydraulic servo-actuators with an on-board hydraulic system. The dynamic control system is integrated into the primary control system and provides a time-varying perturbation capability to the non-rotating swashplate. The RTA was first built as a symmetrical body of revolution that was 33.3 ft in length with a maximum diameter of 5.83 ft. In 1991, the RTA was modified to incorporate a fairing on top to enclose the raised rotor control system and the new rotor balance. The new fairing on top of the RTA is 15.96 ft in length and has a maximum cross-section (3.5-ft wide by 4-ft tall) located near the rotor shaft.

The RTA was mounted in the wind tunnel on a three-strut (two main struts and one tail strut) support system placing the rotor hub nominally one rotor diameter above the wind tunnel floor. Each front main strut support consists of a 12-ft 80- by 120-Foot Wind Tunnel main strut, 0.5-ft strut adapter, 15-ft 40- by 80-Foot Wind Tunnel main strut, and 5-ft tip (see figures 3a - 3c). The model angle-of-attack was varied by changing the height of the gimbaled tail strut. Rotor collective and cyclic pitch controls were introduced through the swashplate by means of three electromechanical/hydraulic actuators. All data presented in this report were acquired with the first harmonic of the rotor flapping angle trimmed to near zero.

Instrumentation And Data Reduction

The new RTA rotor balance and flexcoupling were used to measure the rotor forces and moments. The RTA rotor balance is a five-component balance that measures rotor lift, drag and side forces, together with the rotor pitching and rolling moments. The balance shares a common centerline with the rotor shaft. The instrumented

flexcoupling measures rotor torque and residual lift force. Both the rotor balance and flexcoupling were designed to measure static and dynamic loads. Table 2 lists the general capabilities and static load accuracies of the rotor balance as measured during the calibration. The resultant hub moment capability depends on rotor hub height above the balance moment center; the higher the hub height, the lower the resultant hub moment capability.

The rotor forces and moments were corrected for aerodynamic tares but not for tunnel wall effects. The tare corrections were experimentally determined to account for the aerodynamic forces on the rotating rotor hub (without blades), shaft, and exposed areas of the control system. These were obtained for tunnel velocities from 0 to 100 knots at a nominal rotor speed of 292 rpm. The aerodynamic tares are described by polynomial equations as a function of tunnel dynamic pressure (QPSF) at specific rotor shaft angles-of-attack (α_s) in the balance-axis system in Table 3. The measurement units and positive sign conventions used for the forces and moments are shown in Table 4. These tare reactions were subtracted from the balance forces and moments to obtain the net rotor reactions at the balance-axis system. The net rotor reactions are then transformed from the balance axis system (balance axis has 1.377 deg yaw offset in clockwise direction from rotor hub and wind axis system) to the rotor hub (shaft)-axis system and then into the wind-axis system.

Other instrumentation for this wind tunnel test included nine rotor spindle bending and stress measurements (on one rotor spindle), thirteen blade bending and stress measurements (distributed along one blade), one rotational pitch link load measurement, one blade pitch angle measurement, one blade lead-lag angle measurement, two blade flap angle measurements, two blade damper linear load measurements, one rotating scissors shear load measurement, one non-rotating scissors shear load measurement, three stationary control rod axial load measurements, and standard wind tunnel test section flow measurements. The blade instrumentation is shown schematically in figure 4. Not all of the above measurements are presented in this report. The rotating measurements documented in this report are presented in Table 5 along with the measurement locations, units, and the sign convention.

The signals from the rotating measurements described in Table 5 were sampled and digitized at 64 times per rotor revolution. The data were converted to engineering units using an R-cal step acquired at the beginning of the test run. The time history was smoothed and filtered by eliminating sub harmonics and all harmonics above

20/rev; correction for the Bessel filters in the amplifiers was applied.

Test Procedures and Test Envelope

The test conditions were obtained by establishing shaft angle, rotor tip Mach number, rotor advance ratio μ (tunnel velocity divided by rotor tip speed, ΩR), rotor thrust, and by adjusting cyclic pitch to minimize the rotor first harmonic flapping to within 0.2 deg. Three basic test conditions were investigated. These were hover (YAW = 0 deg, 90 deg), tunnel speed sweeps at specific thrusts and rotor shaft angles-of-attack, and thrust sweeps at specific tunnel speeds and rotor shaft angles-of attack. The full range of test conditions are shown in Tables 6-8. Since the 80- by 120-Foot Wind Tunnel is an open circuit wind tunnel, outside wind conditions can affect the tunnel test section conditions. To alleviate this concern, the majority of the hover and low speed testing was performed when the outside wind speeds were less than 5 kt and the air speed through the test section was less than 4 kt (based on tunnel dynamic pressure measurements).

Hover Rotor Performance

Hover performance data are presented in tabular form in Appendix A and shown graphically in figures 5 and 6. The rotor control positions presented in Appendix A are based on fixed-system actuator positions. Data are placed into two subgroups; first subgroup is YAW = 0 deg and second is YAW = 90 deg. This corresponds to the two basic hover configurations shown in figure 3b. The first configuration was with the model aligned with the tunnel centerline and facing the tunnel inlet. In this configuration, thrust sweeps were conducted at shaft angles from -15 deg to +15 deg (see Appendix A and figure 5). The second configuration was with the model yawed 90 deg clockwise, with the model nose facing the main tunnel access doors at the east wall (see Appendix A). Figure 6 presents hover performance data for the YAW = 90 deg case. Part of the YAW = 0 deg data are also plotted for comparison. For YAW = 90 deg, the rotor shaft centerline was located approximately 73 ft from the west wall. With the tunnel doors open, an 80-ft high by 120-ft wide opening was provided for the rotor wake to exit the facility. In this configuration, thrust sweeps were conducted at a shaft angle of +15 deg.

Forward Flight Rotor Performance

Performance data for forward flight thrust and speed sweep conditions with minimized flapping trim are presented in tabular form in Appendix B. Nomenclature

to identify parameters and a data index for locating specific test conditions are also provided within this appendix. Wall corrections were not applied to this data.

Thrust sweep data runs are shown graphically in figures 7-13. Data runs are grouped in terms of increasing rotor advance ratio and shaft angle-of-attack. The data reported are for thrust sweeps with advance ratios ranging from 0.05 to 0.25 and shaft angles from -15 deg to 10 deg.

Speed sweep data runs are grouped in terms of increasing shaft angle-of-attack and thrust conditions. The tabulated data are for speed sweeps at $C_T/\sigma = 0.065, 0.080,$ and 0.100 for a rotor shaft angle range of -10 deg to 10 deg. The data are graphically presented in figures 14 - 20. In addition to the speed sweep data, figures 14 - 20 also include specific thrust sweep data. Thus, the ranges of conditions for figures 14 - 20 are $C_T/\sigma = 0.030$ to 0.120 at rotor shaft angles of -15 deg to 10 deg for speeds ranging from 0 to 100 kt.

Forward Flight Dynamic Loads Data Summary

A summary of dynamic loads data for forward flight thrust and speed sweep conditions with minimized flapping trim are presented in tabular form in Appendix C. Data runs are grouped in terms of increasing rotor advance ratio and shaft angle-of-attack. For each measurement, the time-averaged mean and one-half peak-to-peak value (absolute maximum minus the absolute minimum divided by 2) are presented. Nomenclature to identify parameters, measurement descriptions and locations, and a data index for locating a specific test condition are provided within the appendix.

Thrust sweep data runs are grouped in terms of increasing rotor advance ratio and shaft angle-of-attack. Advance ratios range from 0.05 to 0.25 and shaft angles from -15 deg to 10 deg.

Speed sweep data runs are grouped in terms of increasing shaft angle-of-attack and thrust. The tabulated data are for speed sweeps at three specific thrust conditions ($C_T/\sigma = 0.065, 0.080, 0.100$) for a rotor shaft angle range of -10 deg to 10 deg.

Forward Flight Detailed Dynamic Loads Data

Detailed dynamic loads data for forward flight thrust and speed sweep conditions with minimized flapping trim are presented in tabular form in Appendix D. For each measurement, the time-averaged mean, one-half peak-to-peak value (absolute maximum minus the absolute minimum divided by 2) are presented. Also, the first twenty harmonics are presented: the harmonics (X_{nc}, X_{ns}) are defined in the following equation:

$$X = X_0 + \sum (X_{nc} \cos n\psi + X_{ns} \sin n\psi) \quad n = 1, 20 \quad (1)$$

Eight revolutions of rotor time history data were recorded and used to calculate X_{nc} and X_{ns} .

Nomenclature to identify parameters, measurement descriptions and locations, and a data index for locating a specific test condition are provided within Appendix D.

Thrust sweep data runs are grouped in terms of increasing rotor advance ratio and shaft angle-of-attack. Advance ratios range from 0.05 to 0.25 and shaft angles from -15 deg to 10 deg.

Speed sweep data runs are grouped in terms of increasing shaft angle-of-attack and thrust. The tabulated data are for speed sweeps at $C_T/\sigma = 0.065, 0.080,$ and 0.100 for a rotor shaft angle range of -10 deg to 10 deg.

References

1. Johnson, W.: Performance and Loads Data From a Wind Tunnel Test of a Full-Scale Rotor With Four Blade Tip Planforms. NASA TM -81229 / USAAVRADCOM TR80-A-9, September 1980.
2. Jepson, D.; Moffitt, R.; Hilzinger, K.; and Bissel, J.: Analysis and Correlation of Test Data From an Advanced Technology Rotor System. NASA CR-3714, August 1983.
3. Shinoda, P.M.; and Johnson, W.: Performance Results from a Test of an S-76 Rotor in the NASA Ames 80- by 120-Foot Wind Tunnel. AIAA Paper 93-3414, AIAA Eleventh Applied Aerodynamics Conference, Monterey, CA, August 1993.
4. Yamauchi, G.; Signor, D.; Watts, M.; Hernandez, F.; and LeMasurier, P.: Flight Measurements of Blade-Vortex Interaction Noise Including Comparisons with Full-Scale Wind Tunnel Data. American Helicopter Society 49th Annual Forum, St. Louis, MO, May 1993.
5. Shinoda, P.M.: Wall Interaction Effects for a Full-Scale Helicopter Rotor in the NASA Ames 80- by 120-Foot Wind Tunnel. Paper No. 20, AGARD 73rd Fluid Dynamics Panel Meeting and Symposium on Wall Interference, Support Interference, and Flow Field Measurements, Brussels, Belgium, 4-7 October 1993.
6. Swanson, A.: Application of the Shadowgraph Flow Visualization Technique to a Full-Scale Helicopter in Hover and Forward Flight. AIAA Paper 93-3411, AIAA Eleventh Applied Aerodynamics Conference, Monterey, CA, August 1993.

Table 1. General characteristics of the S-76 main rotor

Parameter	Value
Radius	22 ft
Nominal Chord	15.5 in
Nominal twist	-10 deg
Blade Reference Area	113.67 ft ²
Solidity Ratio	.0748
Number of Blades	4
Airfoils	SC1095 84% outboard SC1095R8 80% inboard
Flapping Hinge offset	3.70% radius
Lock No.	11.6
100% RPM	293
100% tip speed	675 fps

Table 2. RTA Rotor balance capabilities and static load accuracies at the balance moment center

Measurement Parameters	Maximum Capacity	Measured Standard Deviation of Error	
		Value	% Capacity
Normal Force or Lift (NF), lb	22,000	25	0.12
Side Force (SF), lb	4,400	7	0.16
Axial Force or Drag (AF), lb	4,400	12	0.27
Pitching Moment (PM), ft-lb	57,833	27	0.05
Rolling Moment (RM), ft-lb	57,833	42	0.07
Torque(TQ), ft-lb	36,083	--	--

Table 3. Aero tare coefficient matrix

$$\text{Aero Load} = C0 + C1 * QPSF + C2 * QPSF^2$$

ALFS,U	Balance Parameter	C0	C1	C2
-15°	NF	0.000000E+00	-0.326101E+01	0.476469E-01
	AF	0.000000E+00	0.661349E+01	0.143181E-02
	SF	0.000000E+00	0.000000E+00	0.000000E+00
	PM	0.000000E+00	0.370070E+02	-0.296749E-01
	RM	0.000000E+00	-0.896100E+00	0.971002E-02
	TQ	0.106000E+03	0.194928E+01	-0.21002E-01
-10°	NF	0.000000E+00	-0.298026E+01	0.584926E-01
	AF	0.000000E+00	0.684417E+01	-0.163840E-01
	SF	0.000000E+00	-0.384309E+00	0.145089E-02
	PM	0.000000E+00	0.352023E+02	-0.256171E-01
	RM	0.000000E+00	-0.562534E+00	0.181376E-02
	TQ	0.106000E+03	0.274941E+01	-0.382801E-01
-5°	NF	0.000000E+00	0.000000E+00	0.000000E+00
	AF	0.000000E+00	0.000000E+00	0.000000E+00
	SF	0.000000E+00	-0.986075E+00	0.290571E-01
	PM	0.000000E+00	0.366249E+02	-0.117064E-01
	RM	0.000000E+00	-0.130419E+01	0.172222E-01
	TQ	0.106000E+03	0.181556E+01	-0.185694E-01
-2°	NF	0.000000E+00	-0.371327E+01	0.116512E+00
	AF	0.000000E+00	0.616055E+01	-0.157009E-01
	SF	0.000000E+00	-0.107114E+01	0.182306E-01
	PM	0.000000E+00	0.356245E+02	-0.376357E-01
	RM	0.000000E+00	-0.102194E+01	0.266390E-01
	TQ	0.106000E+03	-0.194027E+01	-0.119433E-01
0°	NF	0.000000E+00	0.314353E+01	-0.662631E-01
	AF	0.000000E+00	0.590607E+01	0.324471E-02
	SF	0.000000E+00	-0.857955E+00	0.107120E-02
	PM	0.000000E+00	0.353893E+02	-0.353695E-01
	RM	0.000000E+00	-0.135617E+01	0.175815E-01
	TQ	0.106000E+03	0.249418E+01	-0.338657E-01
+5°	NF	0.000000E+00	0.184863E+00	0.969723E-02
	AF	0.000000E+00	0.625300E+01	-0.188129E-01
	SF	0.000000E+00	-0.106543E+01	0.135065E-01
	PM	0.000000E+00	0.354519E+02	-0.399007E-01
	RM	0.000000E+00	-0.236734E+01	0.514371E-01
	TQ	0.106000E+03	0.166225E+01	-0.607216E-03

Table 3. Aero tare coefficient matrix (continued)

$$\text{Aero Load} = C0 + C1 * QPSF + C2 * QPSF^2$$

ALFS,U	Balance Parameter	C0	C1	C2
+10°	NF	0.000000E+00	0.222560E+01	-0.237747E-02
	AF	0.000000E+00	0.535671E+01	0.777188E-02
	SF	0.000000E+00	-0.114855E+01	0.166964E-01
	PM	0.000000E+00	0.344327E+02	-0.295324E-01
	RM	0.000000E+00	-0.139549E+01	0.491692E-02
	TQ	0.106000E+03	0.279907E+01	-0.351700E-01

Table 4. Fixed system measurements

Measurement	Location	Units	Sign Convention
Lift (NF)	Rotor Balance	lb	up
Side (SF)	Rotor Balance	lb	right
Drag (AF)	Rotor Balance	lb	aft
Pitch (PM)	Rotor Balance	ft-lb	nose up
Roll (RM)	Rotor Balance	ft-lb	right wing down

Table 5. Rotating system measurements

Measurement	Blade Number	Location (r/R)	Units	Sign Convention
Flap Bending	1	0.127	ft-lb	tip up
Flap Bending	1	0.200	ft-lb	tip up
Flap Bending	1	0.300	ft-lb	tip up
Flap Bending	1	0.679	ft-lb	tip up
Flap Bending	1	0.920	ft-lb	tip up
Chord Bending	1	0.127	ft-lb	tip aft
Chord Bending	1	0.200	ft-lb	tip aft
Chord Bending	1	0.300	ft-lb	tip aft
Chord Bending	1	0.454	ft-lb	tip aft
Pitch Link	1	Pitch Horn	lb	tension
Flap Angle	1	Pitch Horn	deg	flap up
Rotor Shaft Torque (TQ)	-	center of balance	ft-lb	counter clockwise

Table 6. Hover test matrix

Shaft Angles, α_s	-15°, -10°, -5°, 0°, 5°, 10°, 15°*
C_T/σ	0.02 - 0.12
MTIP	0.605
YAW	0°, 90°*

*Note: For YAW = 90°, hover data taken only at $\alpha_s = +15^\circ$

Table 7. Thrust sweep test matrix

$C_T/\sigma = 0.03-0.125$
 MTIP: 0.605 (675 fps)

		α_s					
VKTS	μ	10°	5°	0°	-2°	-10°	-15°
20	0.050				X		
32	0.080			X			
40	0.100	X	X		X	X	X
50	0.125	X	X				
60	0.150	X	X		X	X	X
80	0.200	X	X		X	X	
100	0.250	X	X		X	X	X

Table 8. Speed sweep test matrix

VKTS = 0-100 kt
 MTIP: 0.605 (675 fps)

		Thrust, lb		
		8,000 ($C_T/\sigma = .065$)	9,850 (.080)	12,320 (.100)
α_s	10°		X	X
	5°	X	X	X
	0°		X	
	-2°	X	X	X
	-5°	X	X	
	-10°	X	X	X

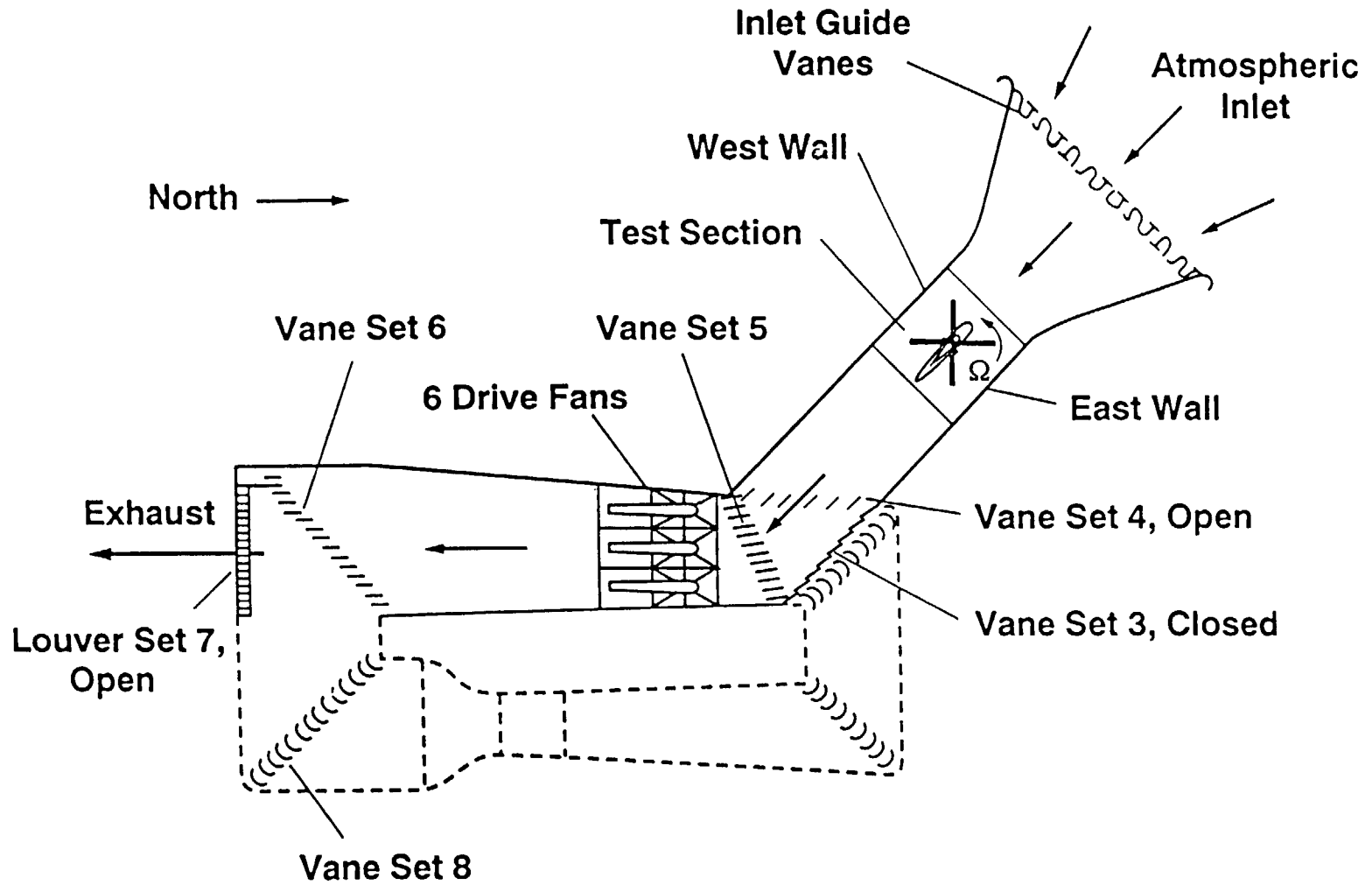

Figure 1. 80- by 120-Foot Wind Tunnel Circuit.



Figure 2. S-76 Rotor System installed on Rotor Test Apparatus in the Ames 80- by 120-Foot Wind Tunnel Test Section.

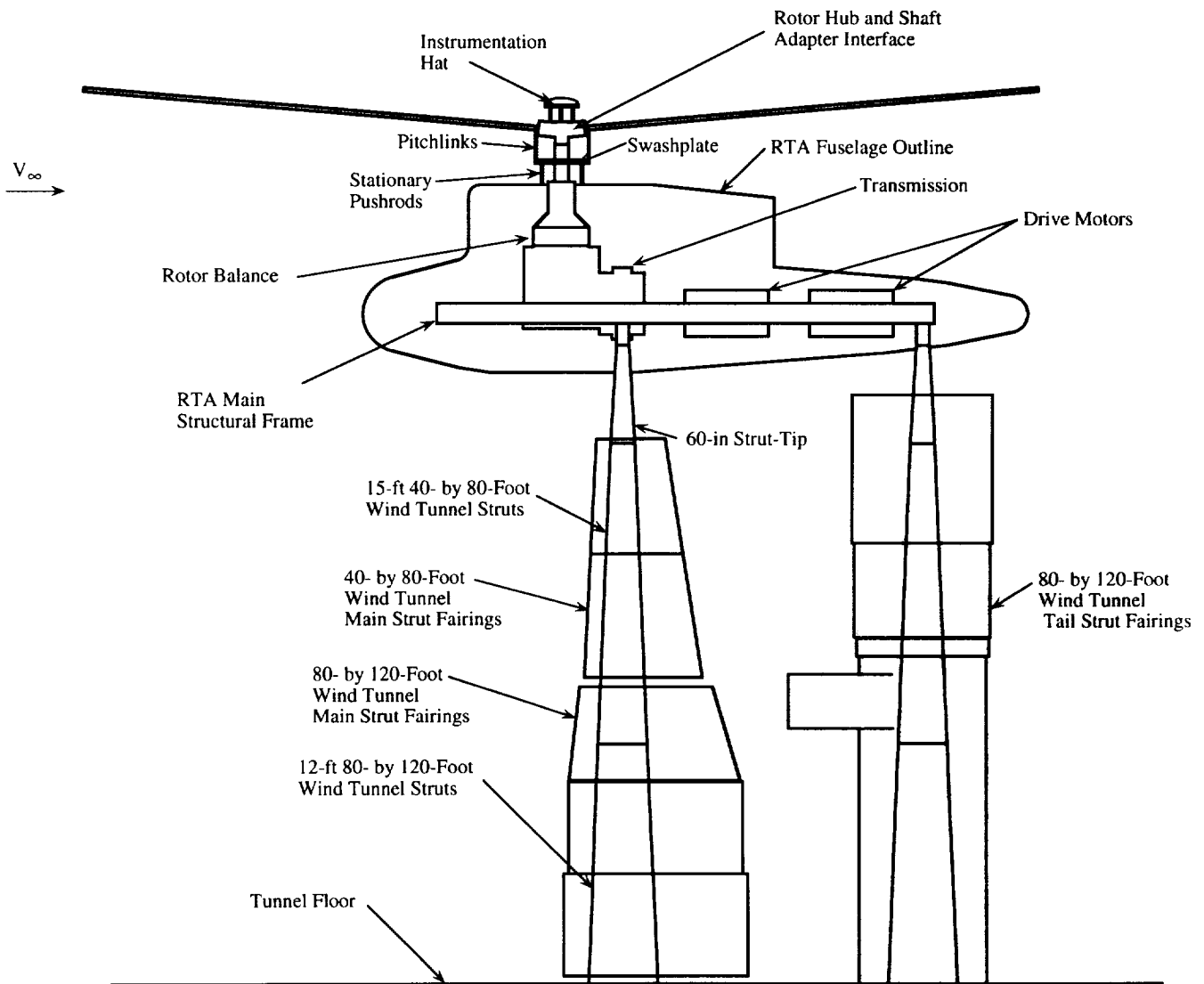

Figure 3a. Schematic of RTA/S-76 rotor test set-up in the 80- by 120-Foot Wind Tunnel.

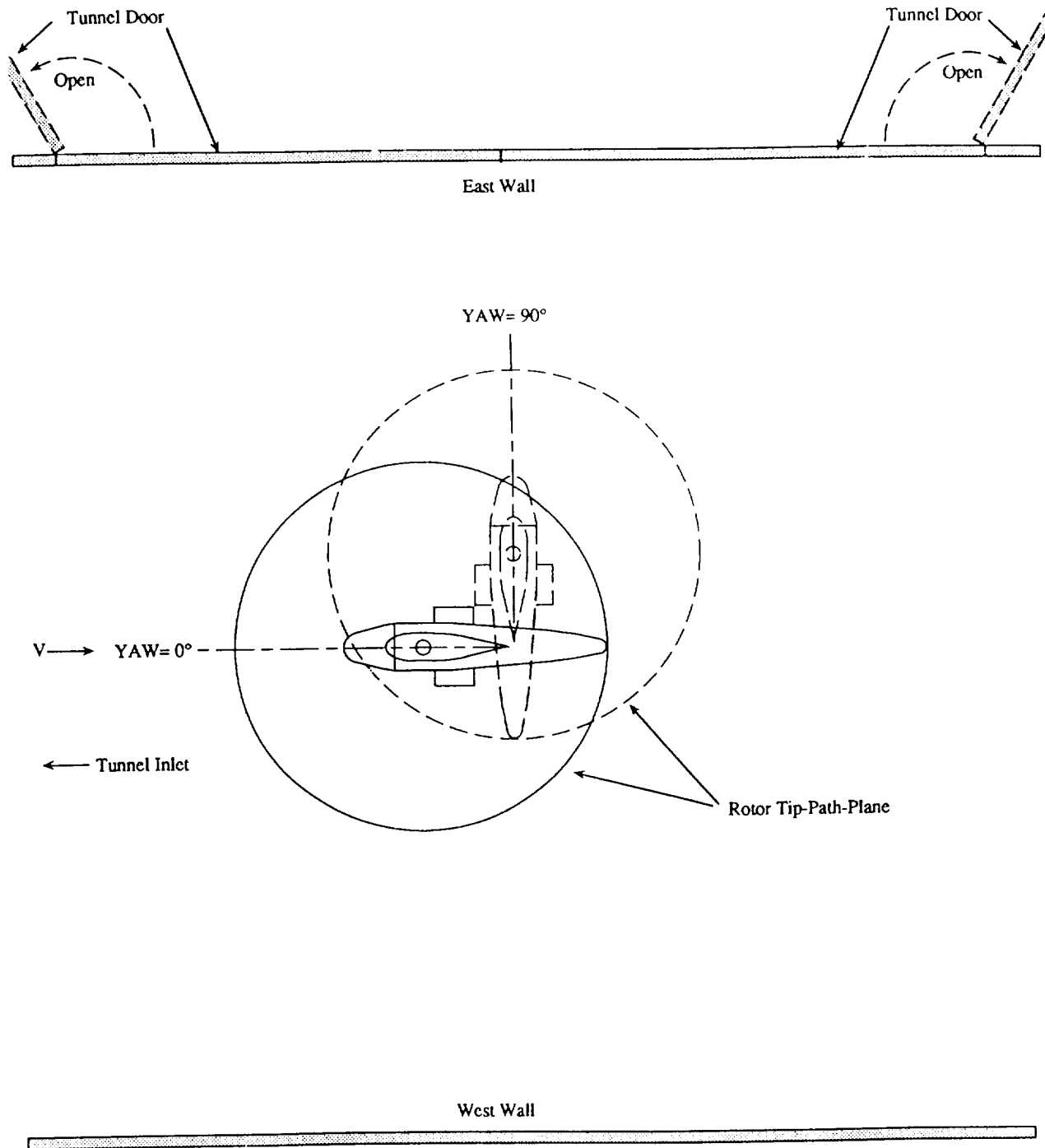

Figure 3(b). Plan view of model in the 80- by 120-Foot Wind Tunnel test section YAW = 0 deg and 90 deg.

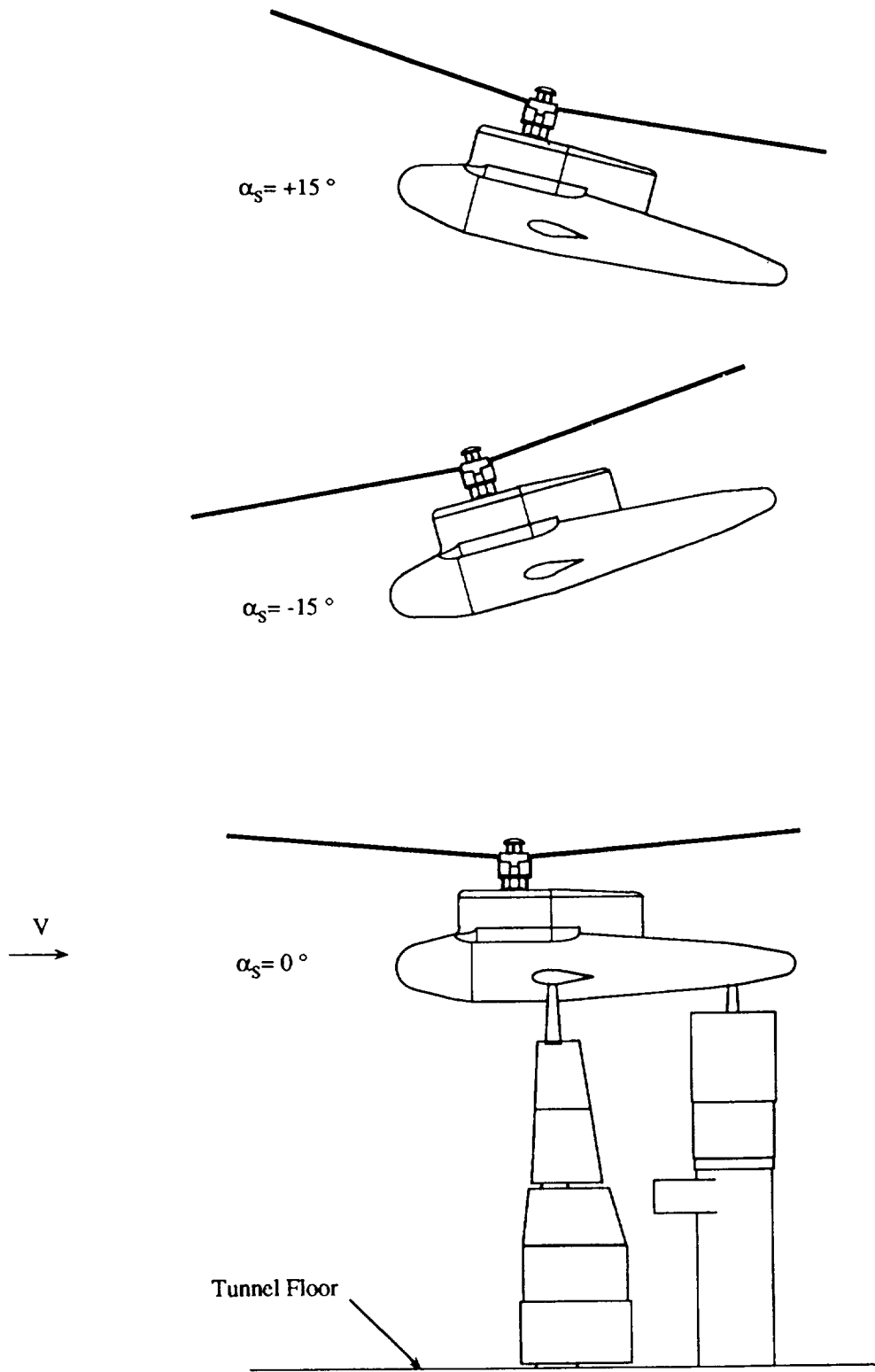

Figure 3(c). Sideview of model in tunnel test section $\alpha_S = 0$ deg, -15 deg and 15 deg.

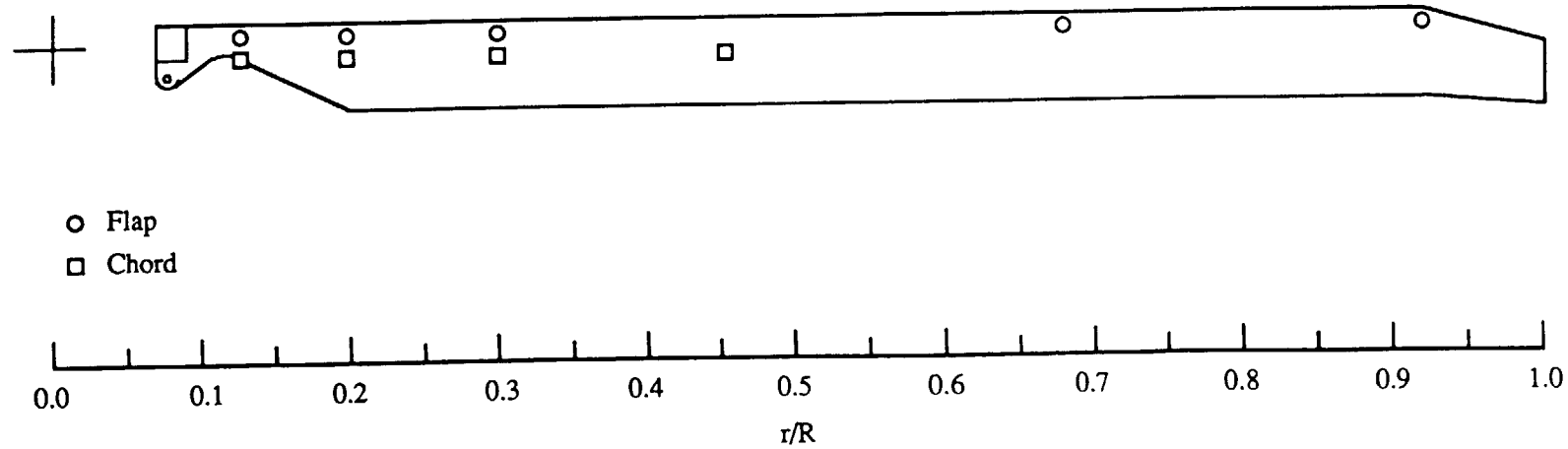

Figure 4. Radial locations of blade flap and chord instrumentation for the wind tunnel test program.

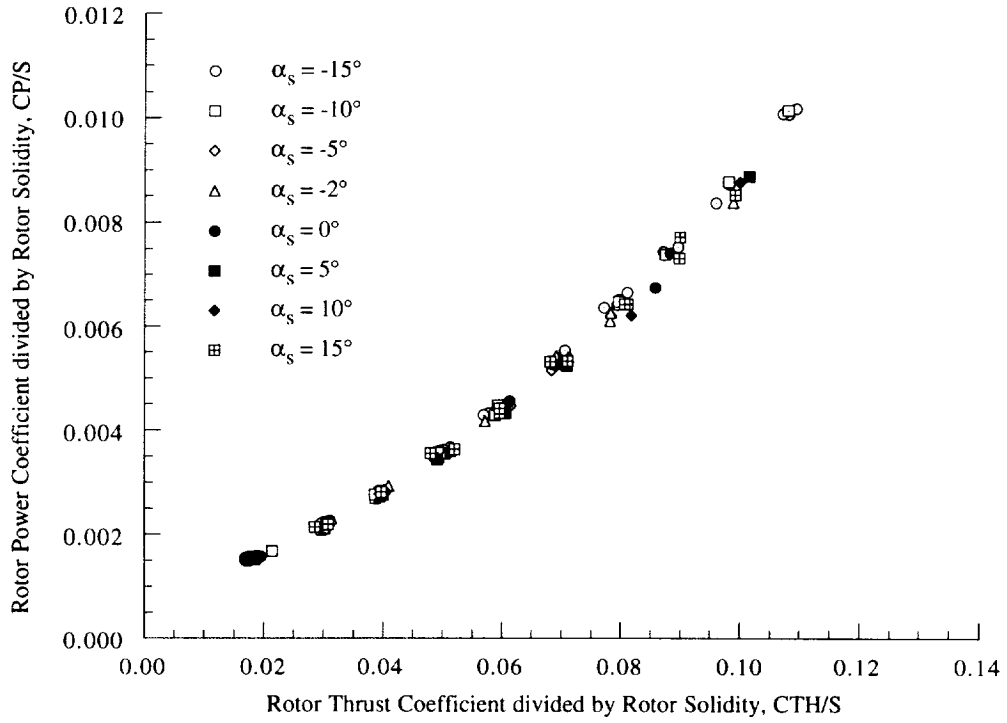

Figure 5(a). Rotor power coefficient as a function of rotor thrust coefficient, YAW = 0 deg, hover.

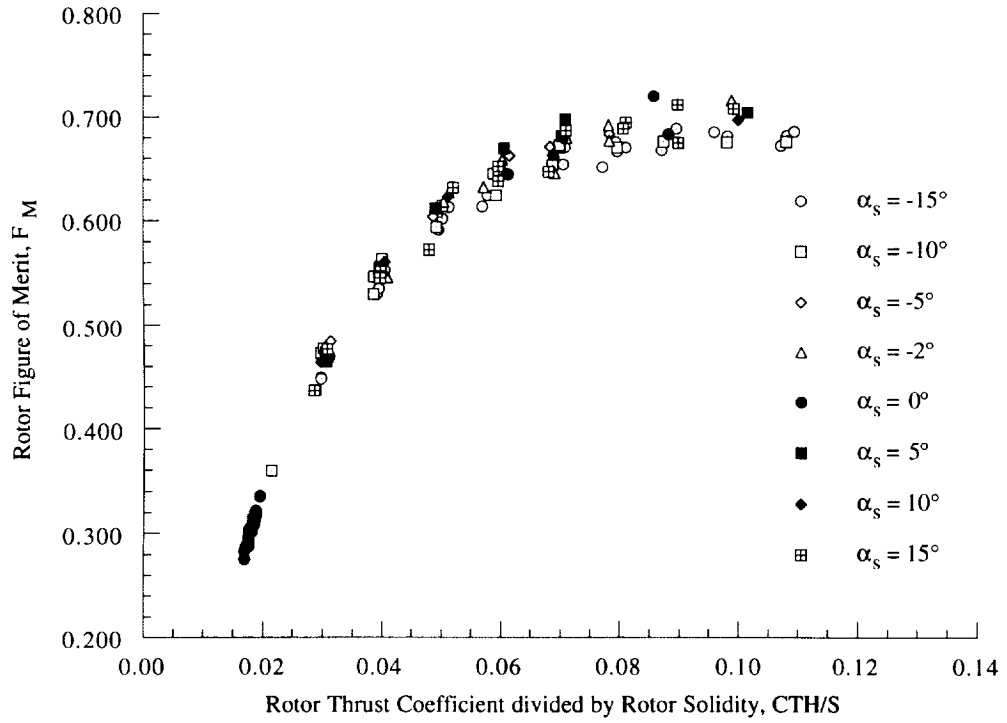

Figure 5(b). Rotor figure of merit as a function of rotor thrust coefficient, YAW = 0 deg, hover.

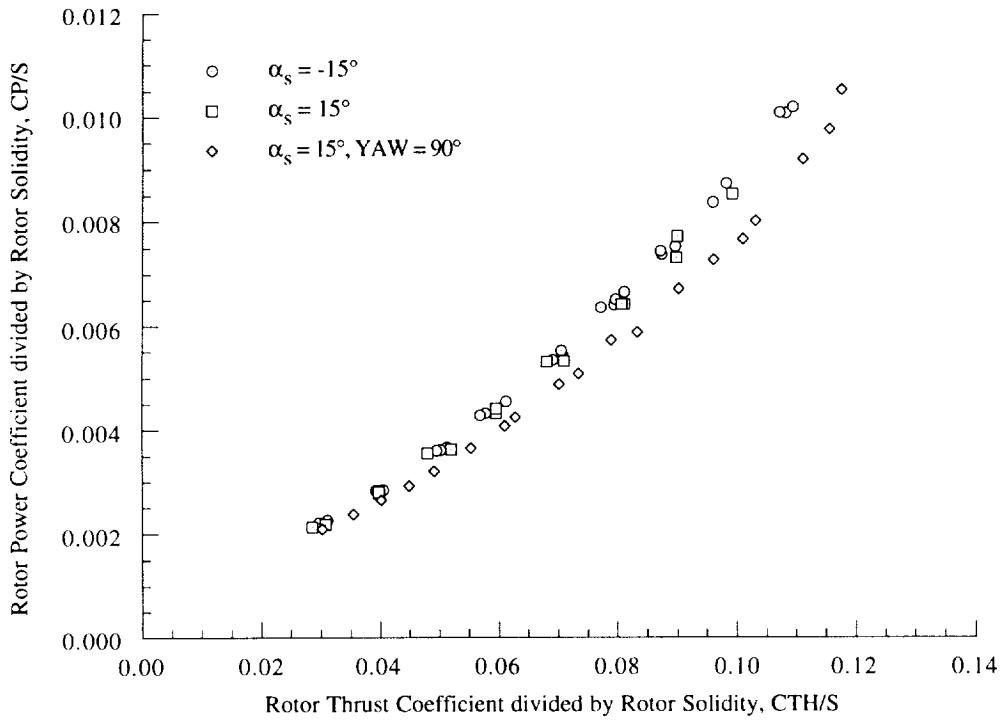

Figure 6(a). Rotor power coefficient as a function of rotor thrust coefficient at two different yaw positions, YAW = 0 deg, 90 deg, hover.

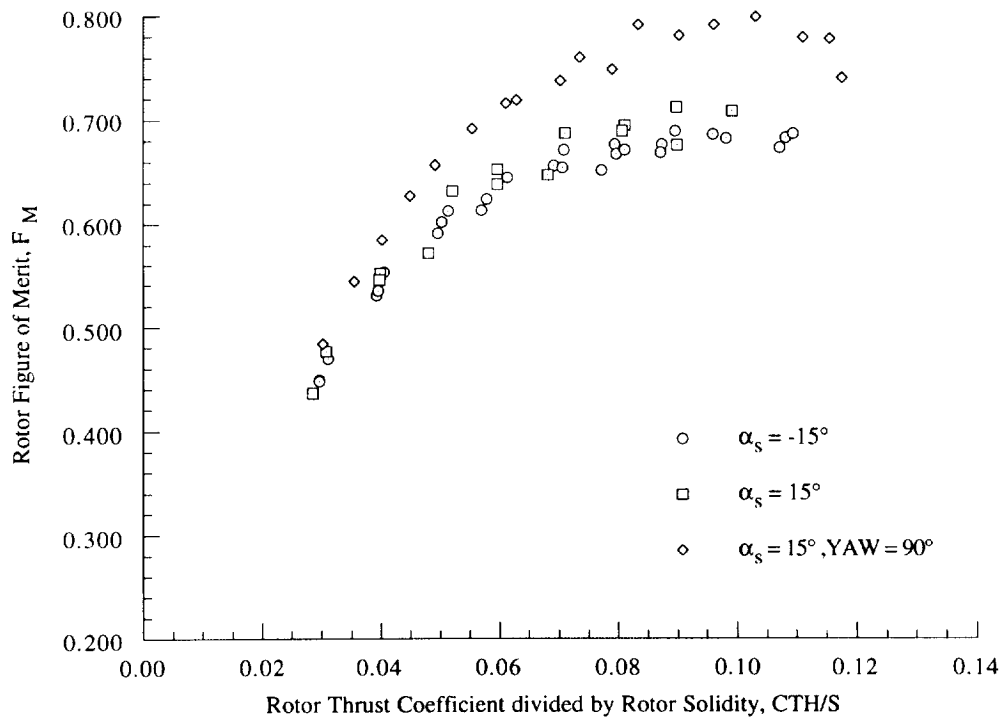

Figure 6(b). Rotor figure of merit as a function of rotor thrust coefficient at two different yaw positions, YAW = 0 deg, 90 deg, hover.

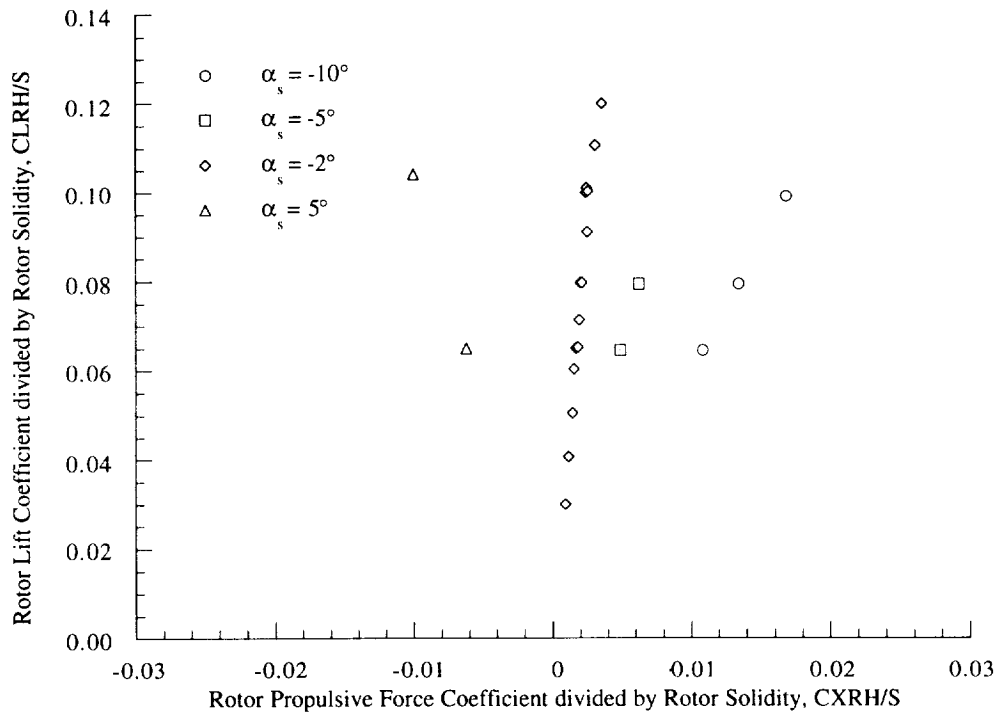

Figure 7(a). Rotor lift coefficient as a function of rotor propulsive force coefficient, 20 knots ($\mu = 0.05$).

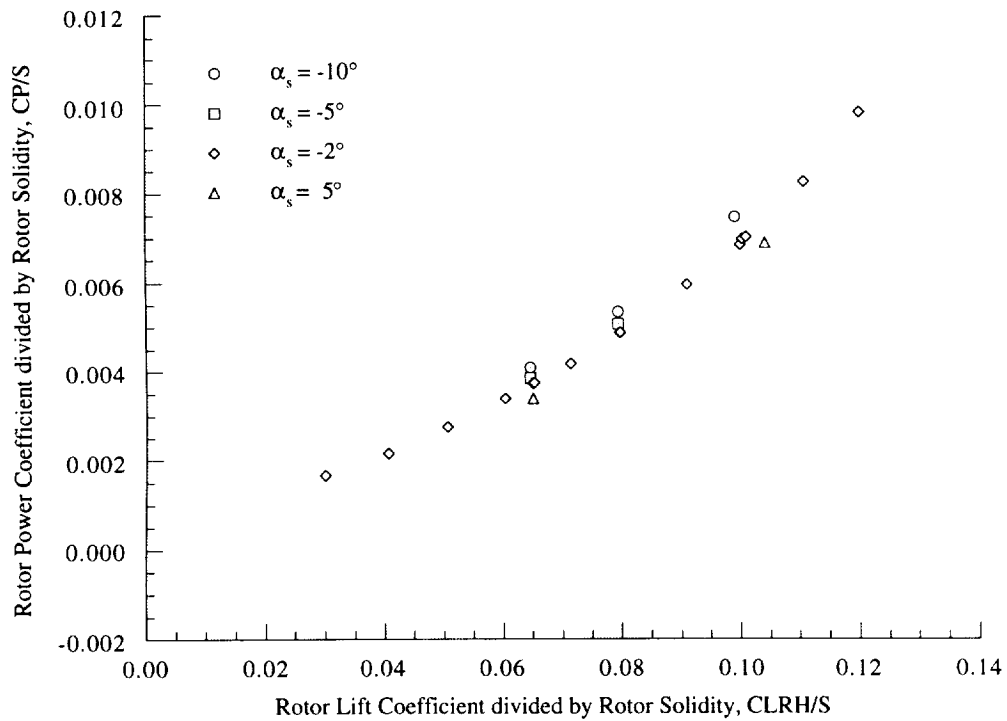

Figure 7(b). Rotor power coefficient as a function of rotor lift coefficient, 20 knots ($\mu = 0.05$).

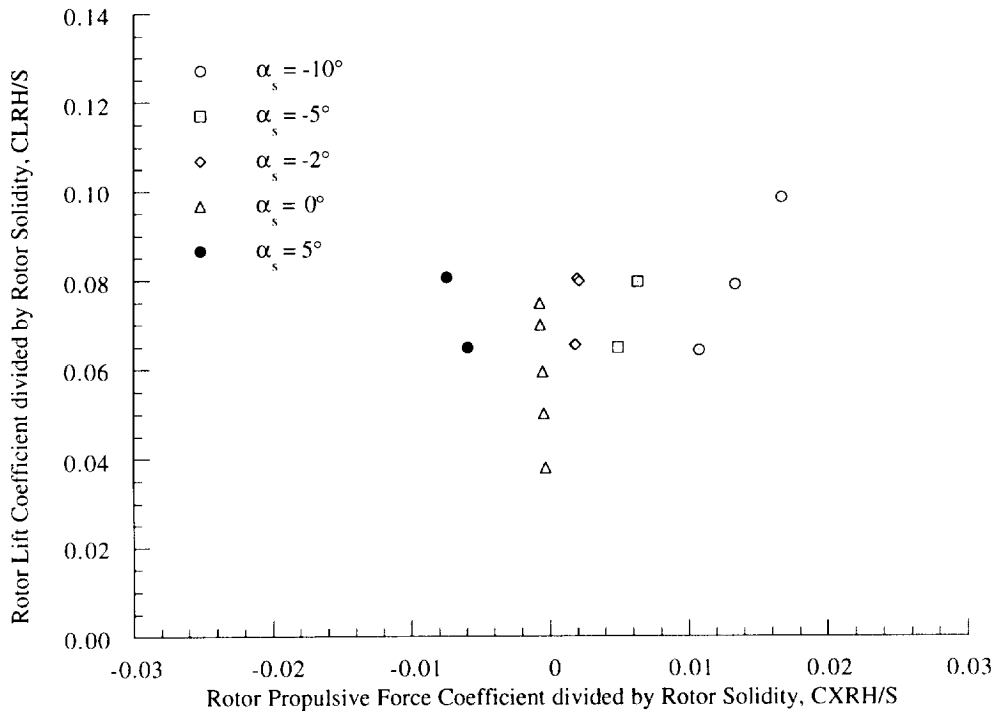

Figure 8(a). Rotor lift coefficient as a function of rotor propulsive force coefficient, 32 knots ($\mu = 0.08$).

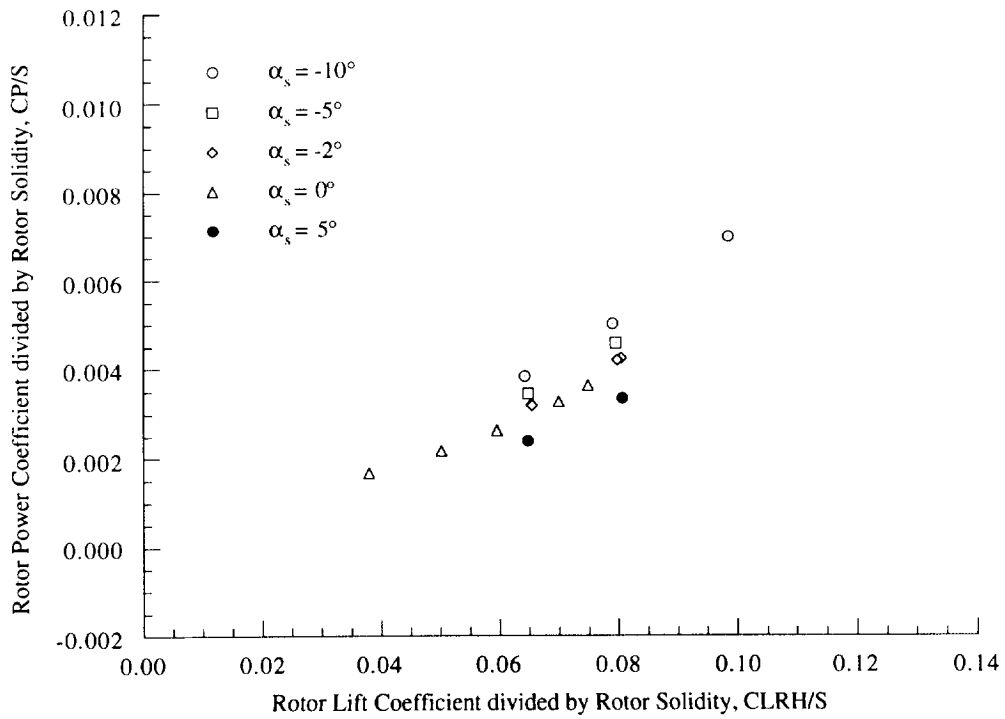

Figure 8(b). Rotor power coefficient as a function of rotor lift coefficient, 32 knots ($\mu = 0.08$).

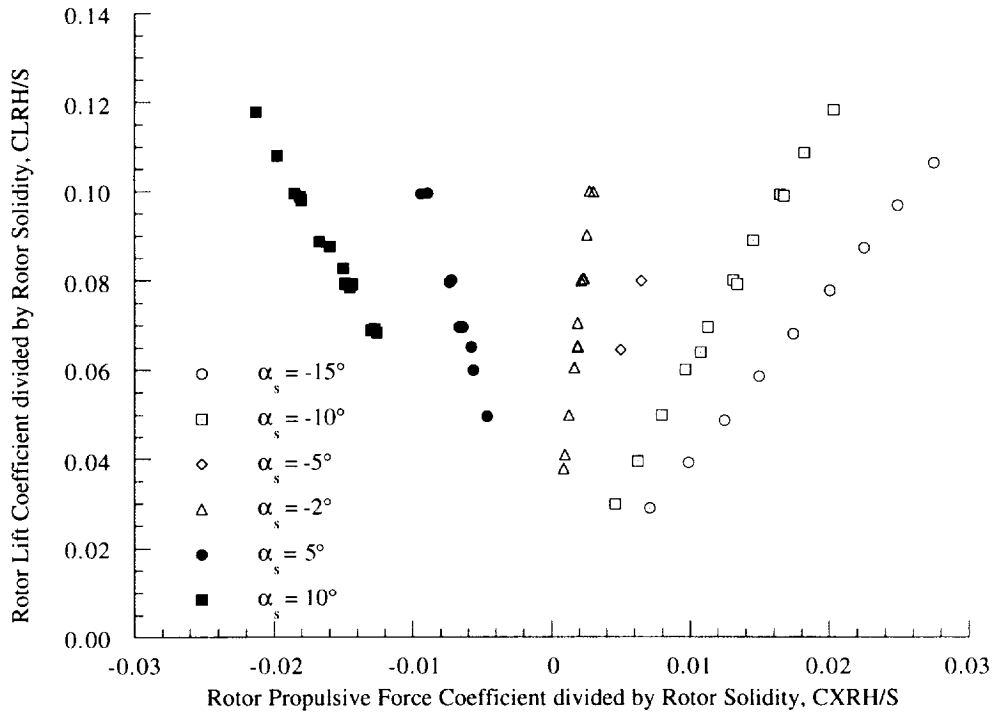

Figure 9(a). Rotor lift coefficient as a function of rotor propulsive force coefficient, 40 knots ($\mu = 0.10$).

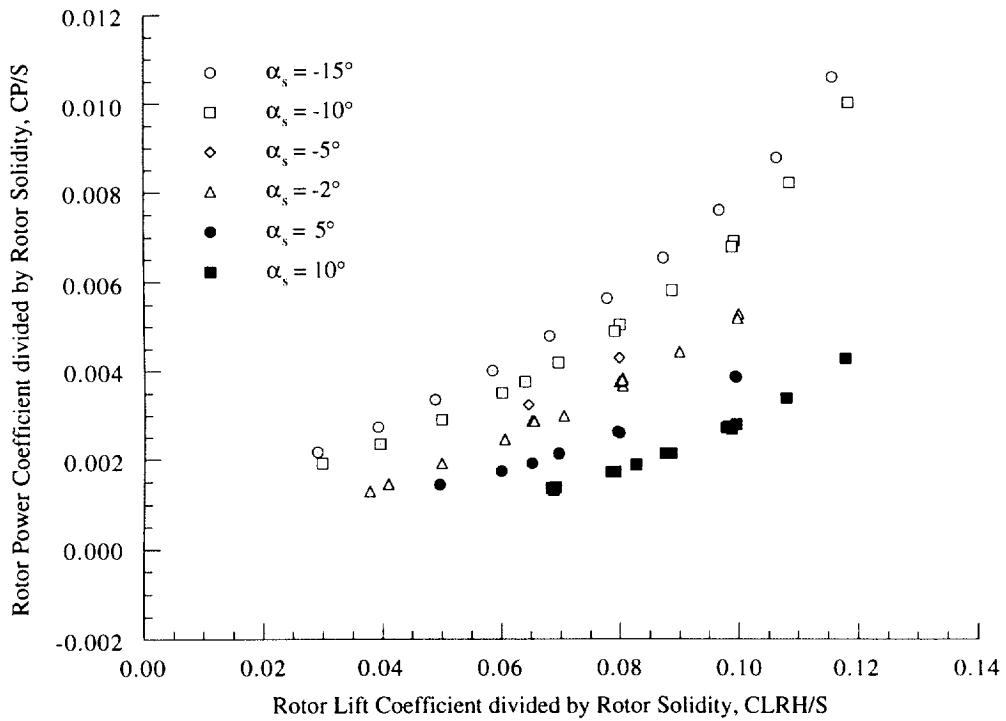

Figure 9(b). Rotor power coefficient as a function of rotor lift coefficient, 40 knots ($\mu = 0.10$).

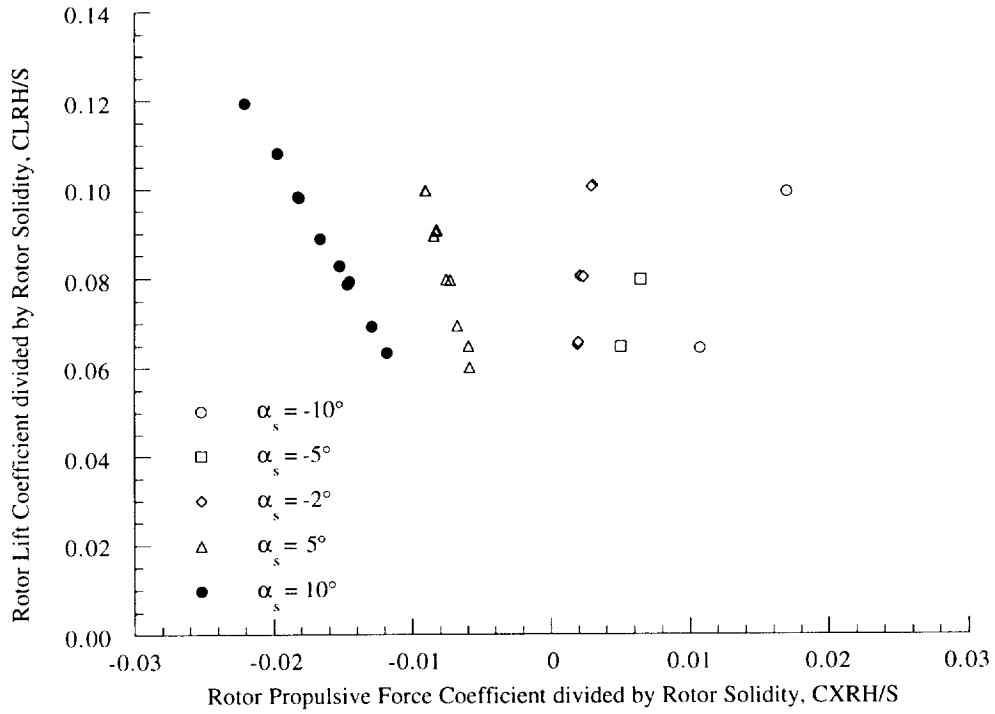

Figure 10(a). Rotor lift coefficient as a function of rotor propulsive force coefficient, 50 knots ($\mu = 0.125$).

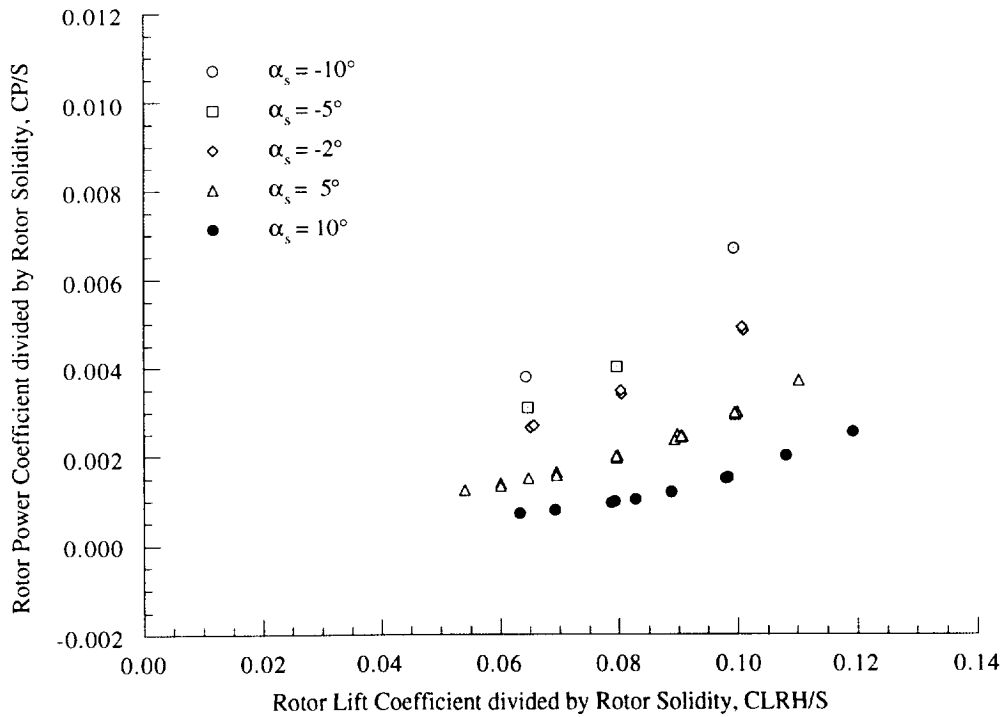

Figure 10(b). Rotor power coefficient as a function of rotor lift coefficient, 50 knots ($\mu = 0.125$).

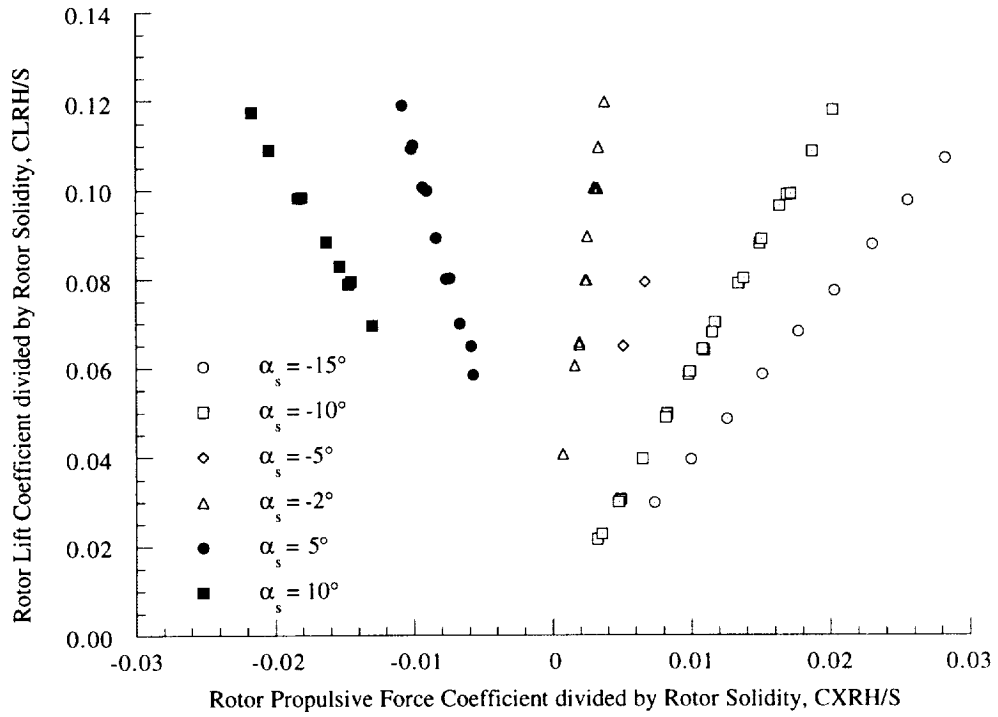

Figure 11(a). Rotor lift coefficient as a function of rotor propulsive force coefficient, 60 knots ($\mu = 0.15$).

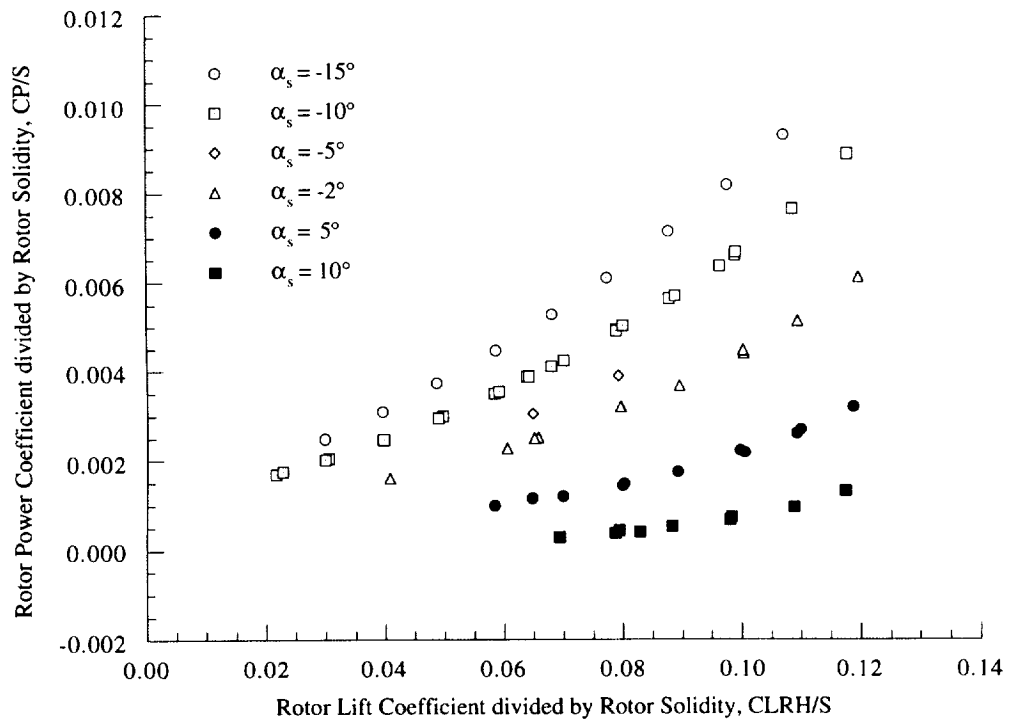

Figure 11(b). Rotor power coefficient as a function of rotor lift coefficient, 60 knots ($\mu = 0.15$).

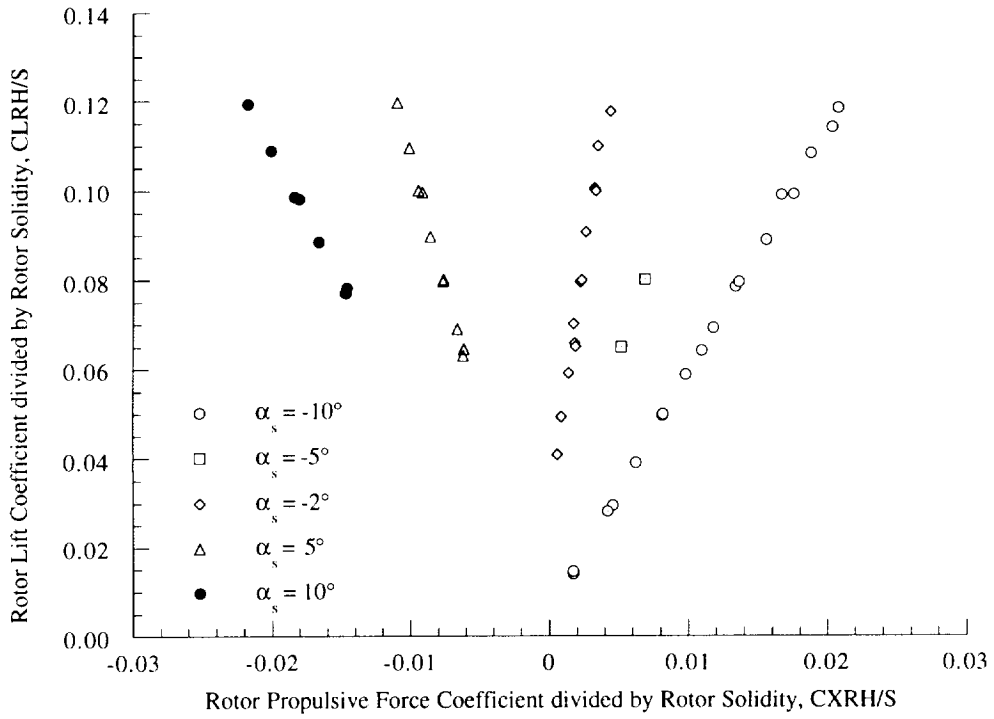

Figure 12(a). Rotor lift coefficient as a function of rotor propulsive force coefficient, 80 knots ($\mu = 0.20$).

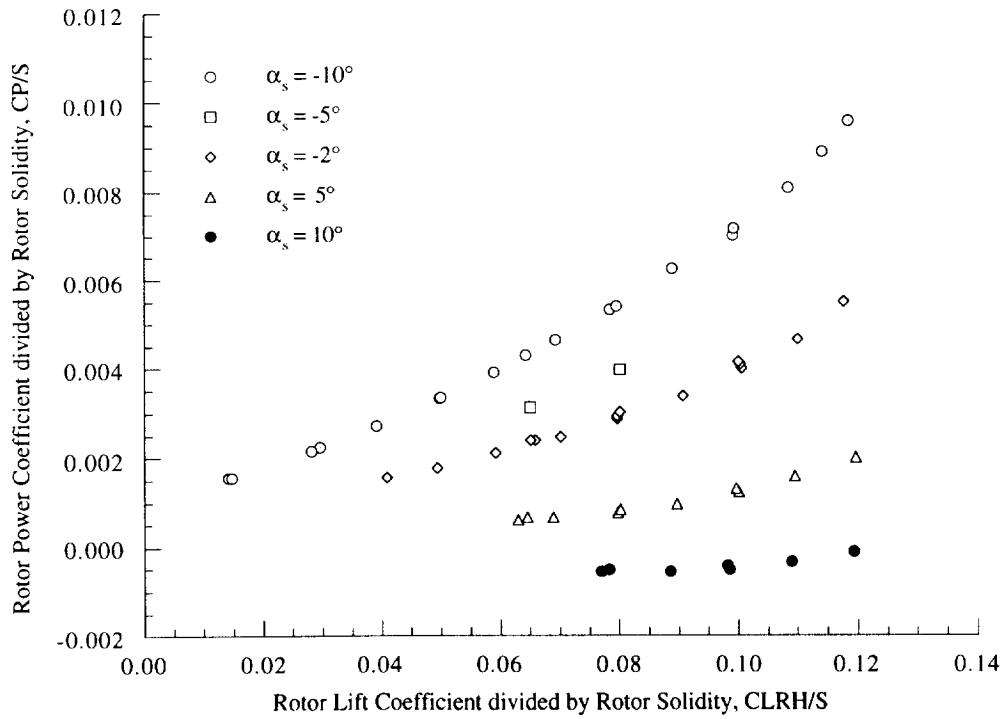

Figure 12(b). Rotor power coefficient as a function of rotor lift coefficient, 80 knots ($\mu = 0.20$).

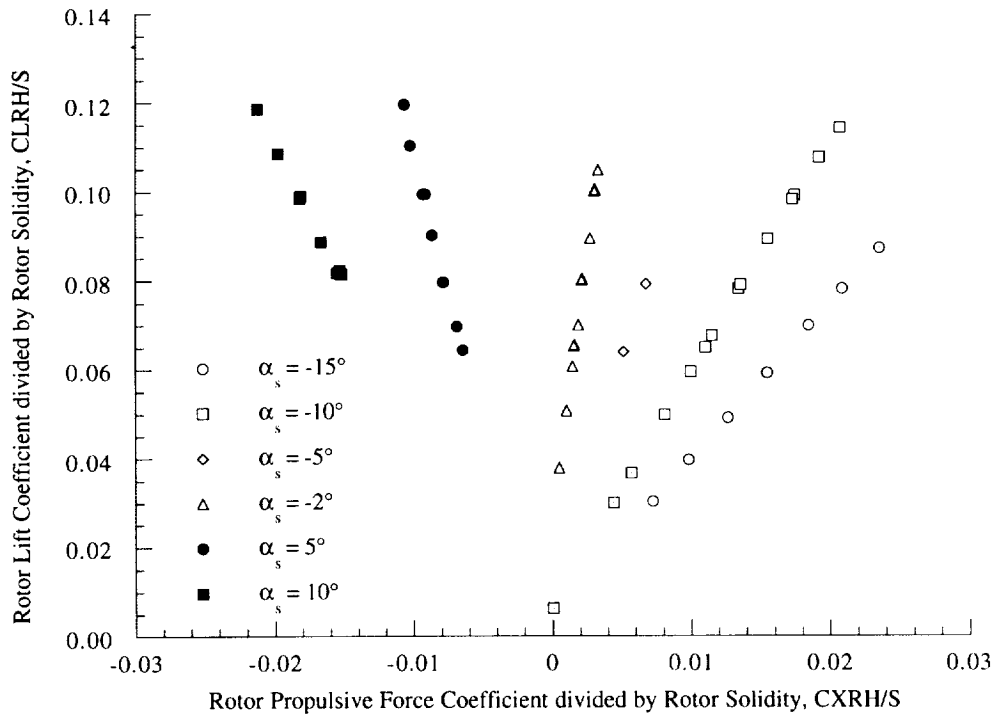

Figure 13(a). Rotor lift coefficient as a function of rotor propulsive force coefficient, 100 knots ($\mu = 0.25$).

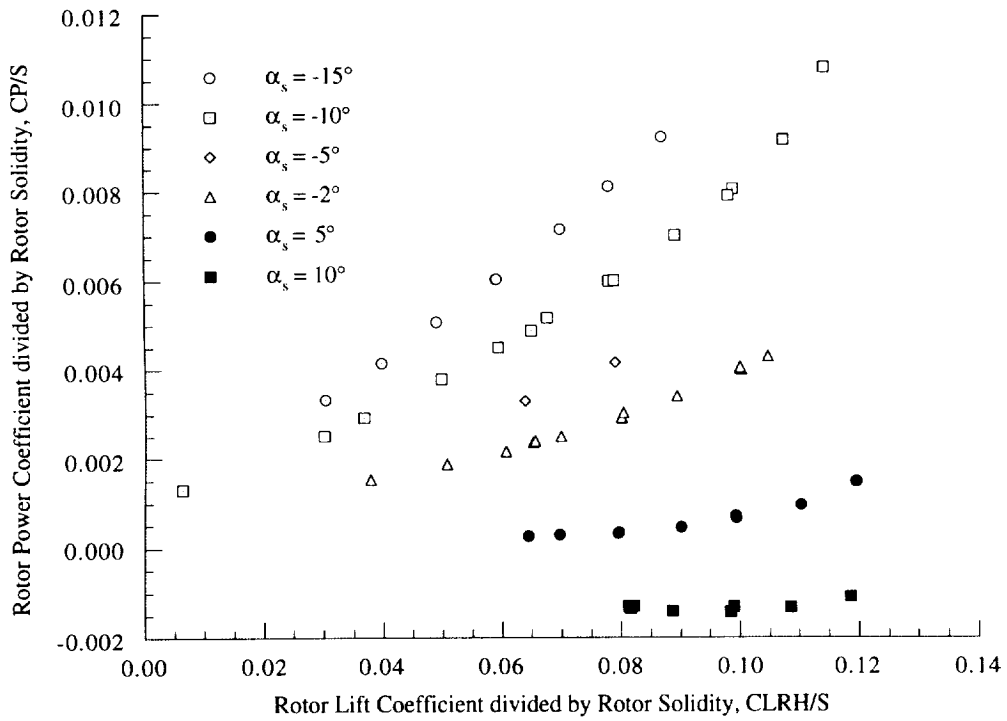

Figure 13(b). Rotor power coefficient as a function of rotor lift coefficient, 100 knots ($\mu = 0.25$).

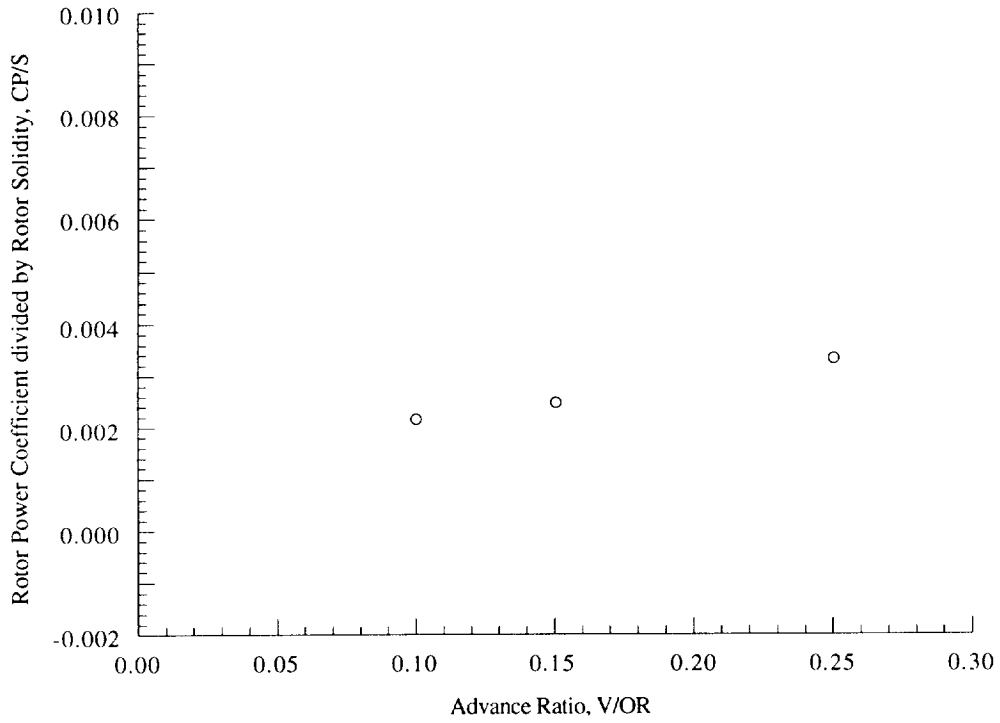

Figure 14(a). Rotor power coefficient as a function of advance ratio, $\alpha_S = -15$ deg, $C_T/\sigma = 0.030$.

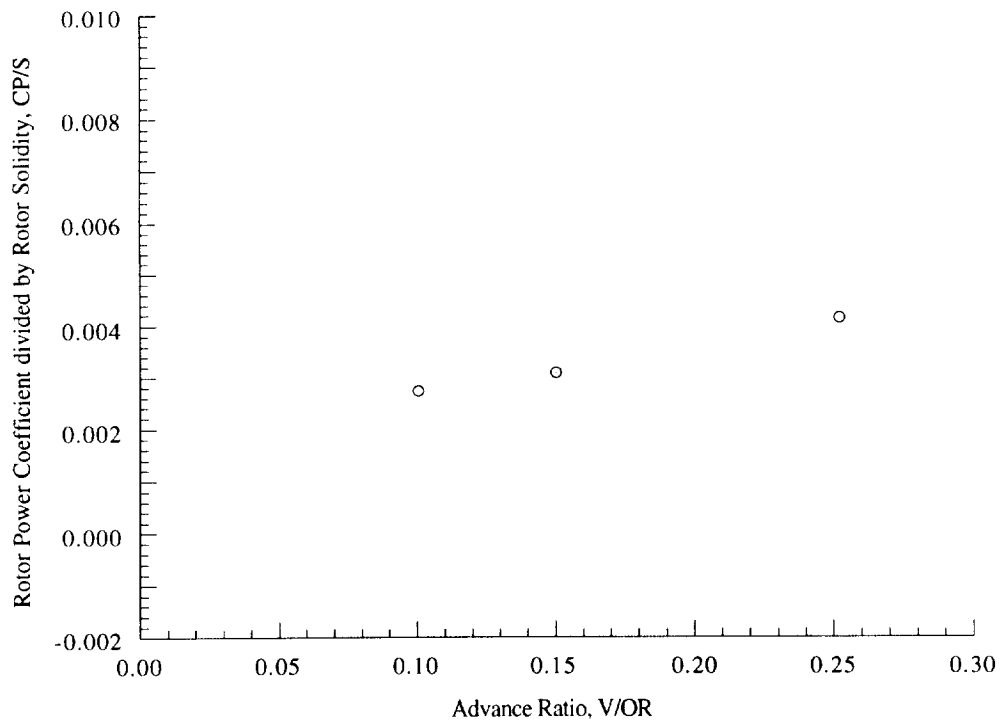

Figure 14(b). Rotor power coefficient as a function of advance ratio, $\alpha_S = -15$ deg, $C_T/\sigma = 0.040$.

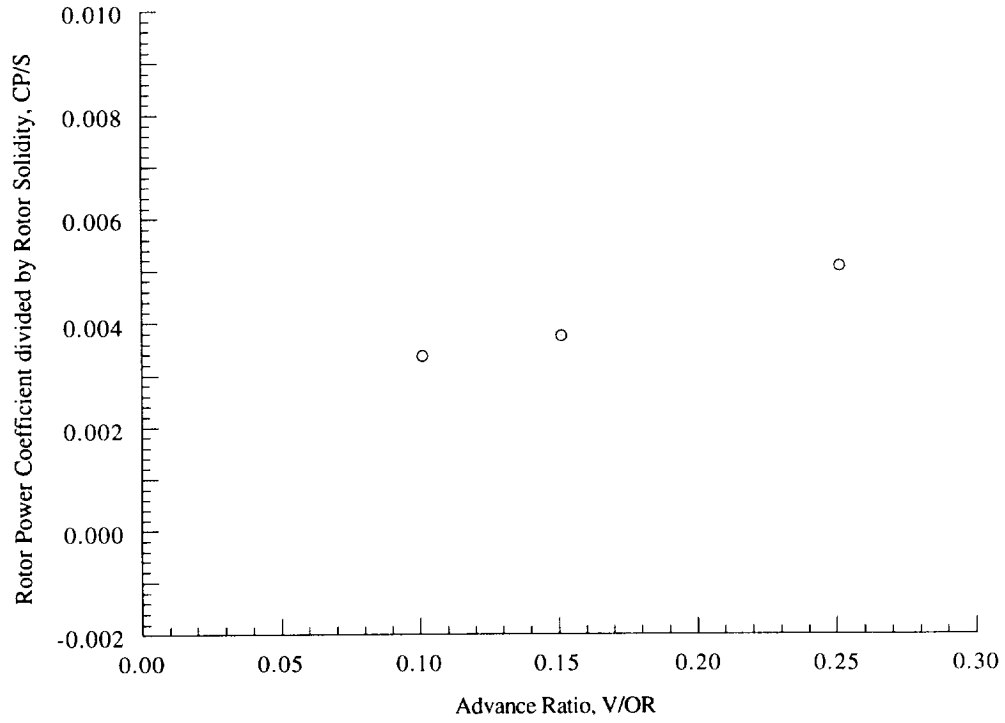

Figure 14(c). Rotor power coefficient as a function of advance ratio, $\alpha_S = -15$ deg, $C_T/\sigma = 0.050$.

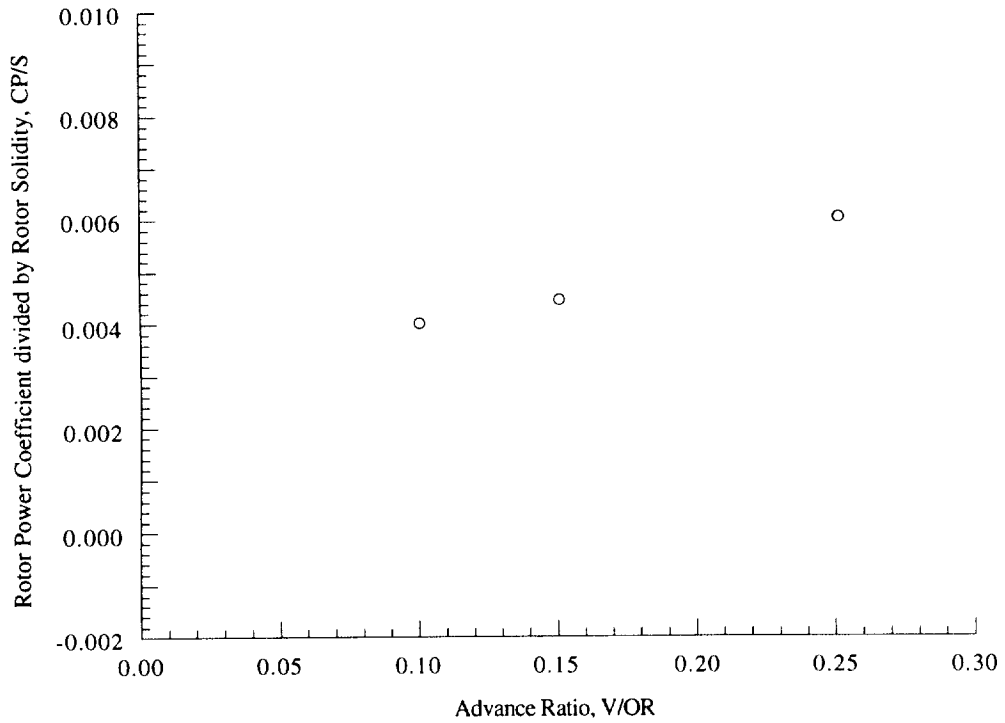

Figure 14(d). Rotor power coefficient as a function of advance ratio, $\alpha_S = -15$ deg, $C_T/\sigma = 0.060$.

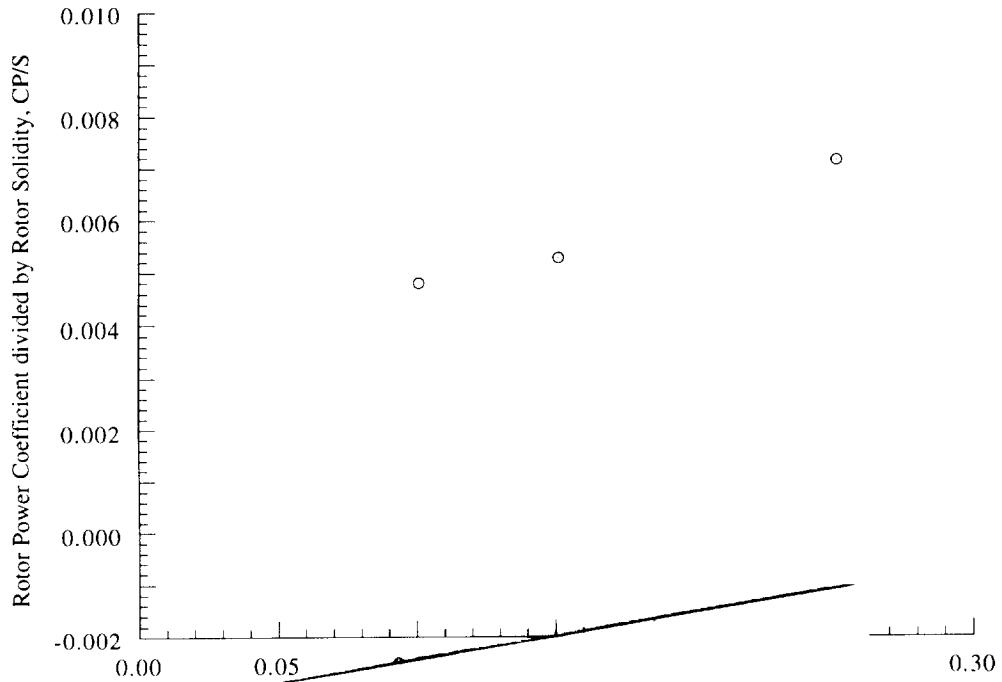

Figure 14(e)

$\tau/\sigma = 0.070$.

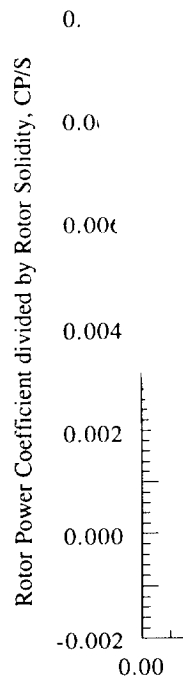

Figure 14(f). Rotor 1

$\tau/\sigma = 0.080$.

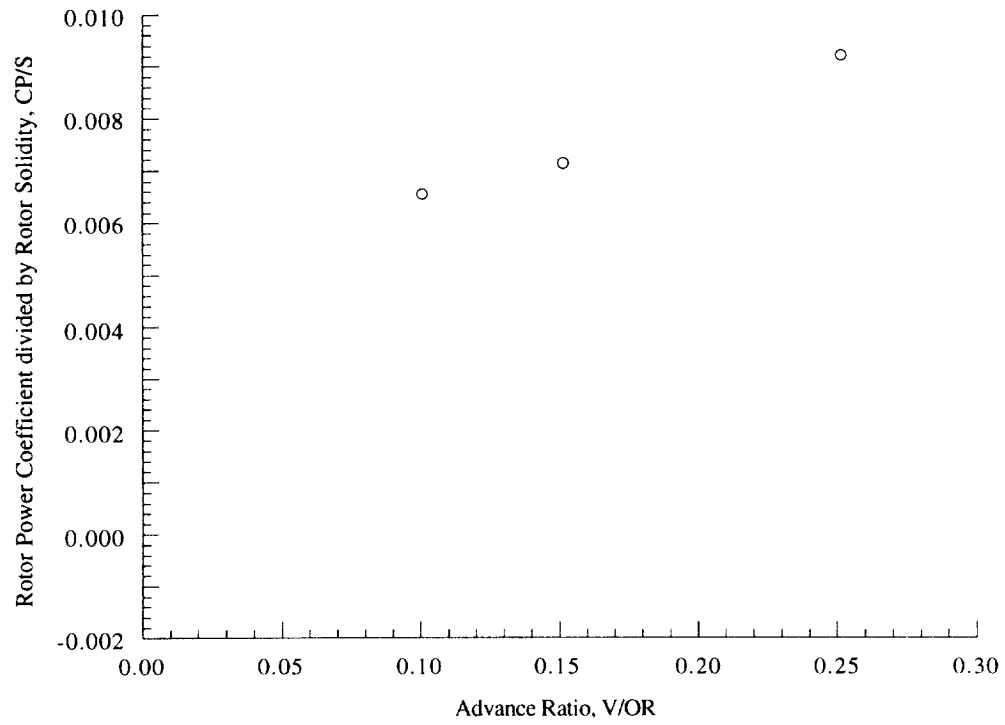

Figure 14(g). Rotor power coefficient as a function of advance ratio, $\alpha_S = -15$ deg, $C_T/\sigma = 0.090$.

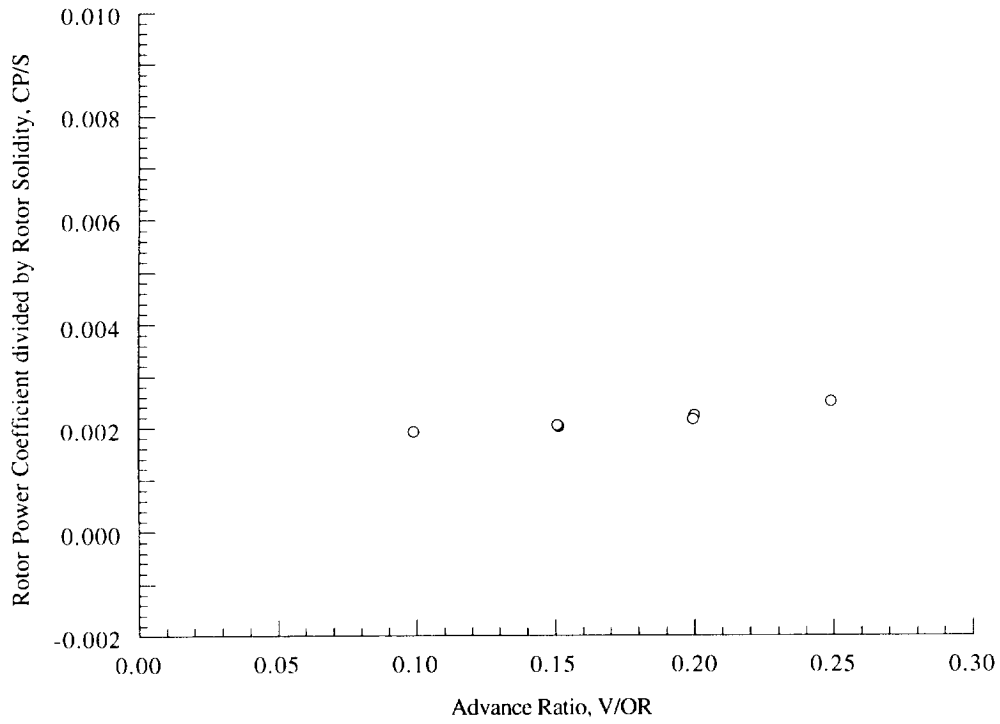

Figure 15(a). Rotor power coefficient as a function of advance ratio, $\alpha_S = -10$ deg, $C_T/\sigma = 0.030$.

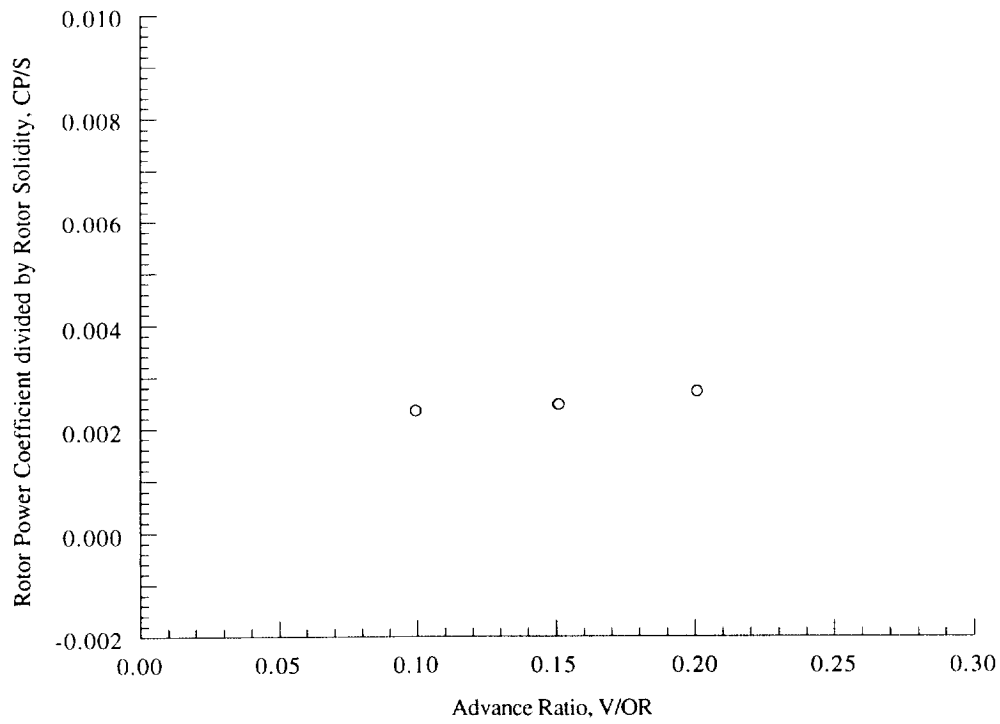

Figure 15(b). Rotor power coefficient as a function of advance ratio, $\alpha_S = -10$ deg, $C_T/\sigma = 0.040$.

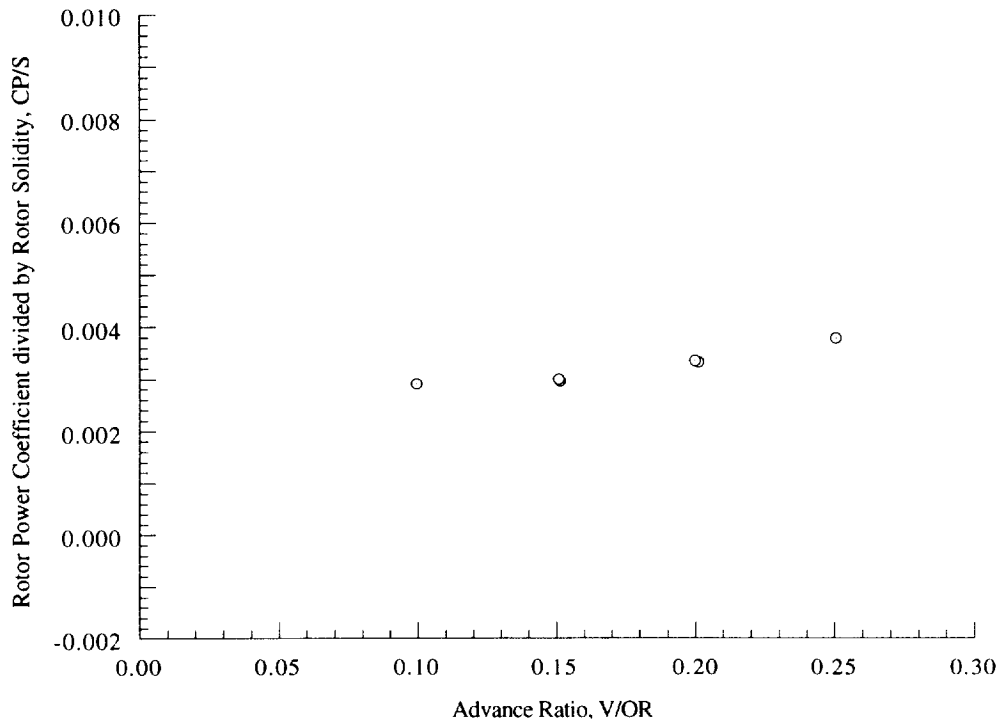

Figure 15(c). Rotor power coefficient as a function of advance ratio, $\alpha_S = -10$ deg, $C_T/\sigma = 0.050$.

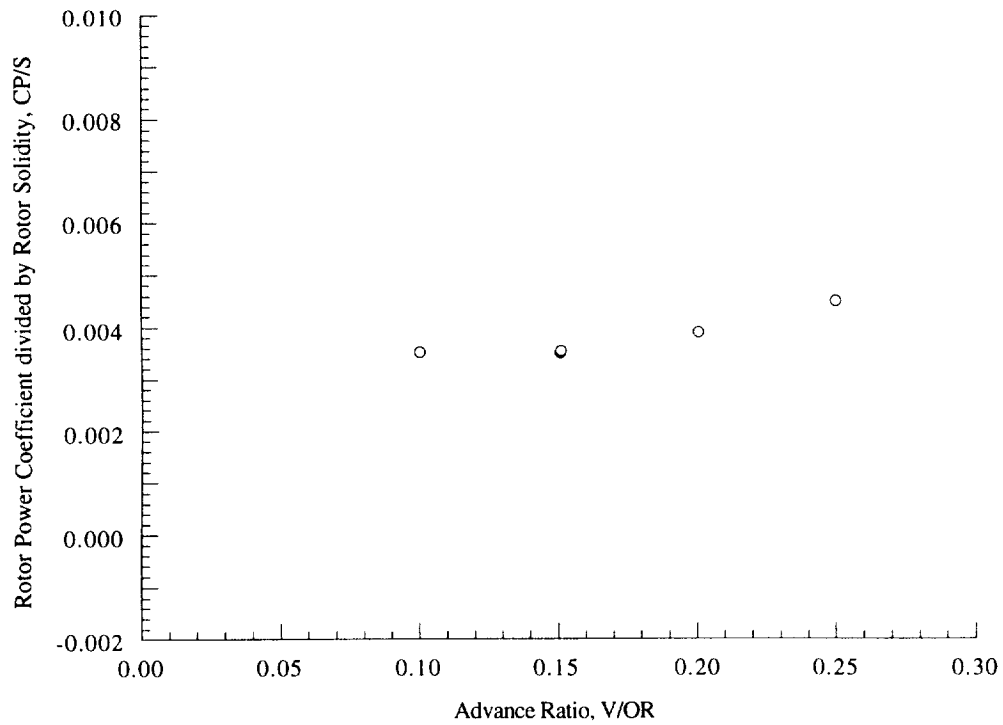

Figure 15(d). Rotor power coefficient as a function of advance ratio, $\alpha_S = -10$ deg, $C_T/\sigma = 0.060$.

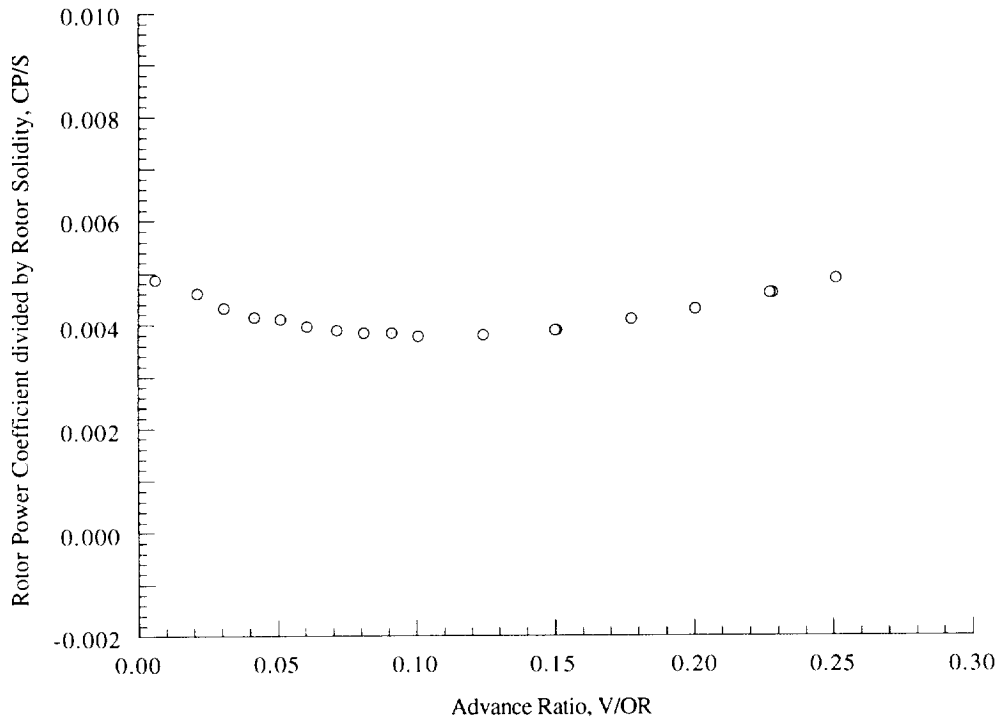

Figure 15(e). Rotor power coefficient as a function of advance ratio, $\alpha_S = -10$ deg, $C_T/\sigma = 0.065$.

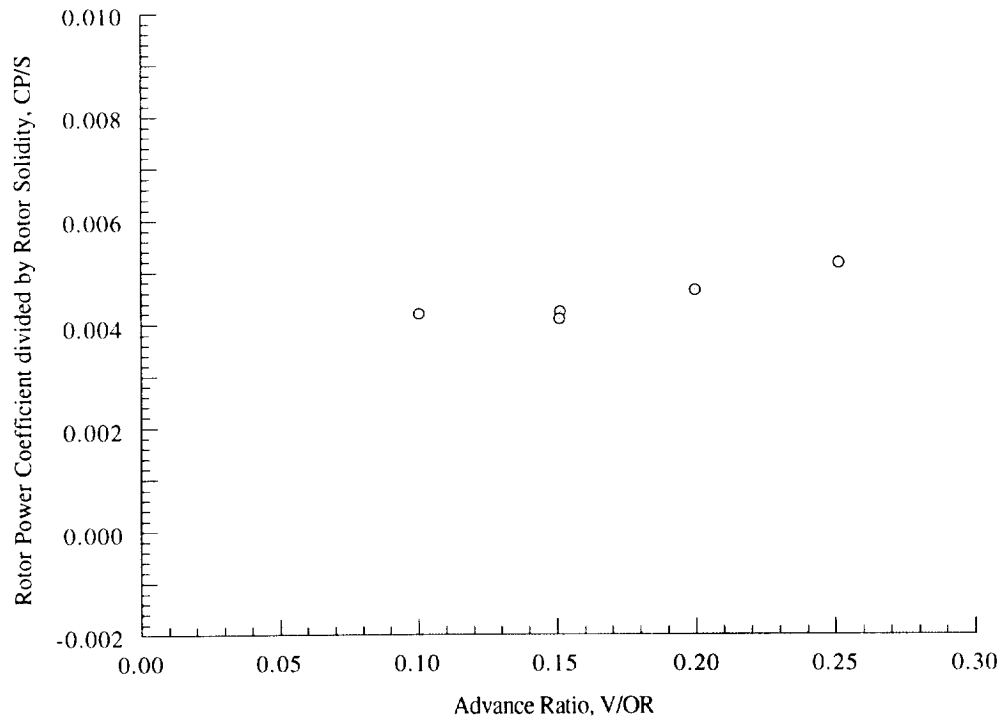

Figure 15(f). Rotor power coefficient as a function of advance ratio, $\alpha_S = -10$ deg, $C_T/\sigma = 0.070$.

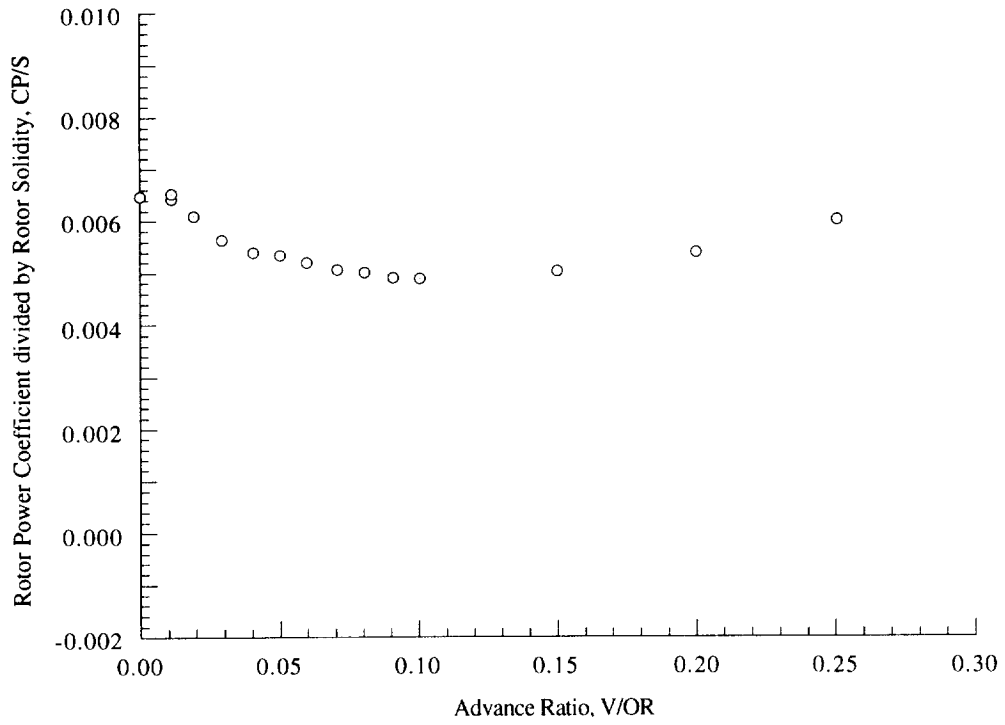

Figure 15(g). Rotor power coefficient as a function of advance ratio, $\alpha_S = -10$ deg, $C_T/\sigma = 0.080$.

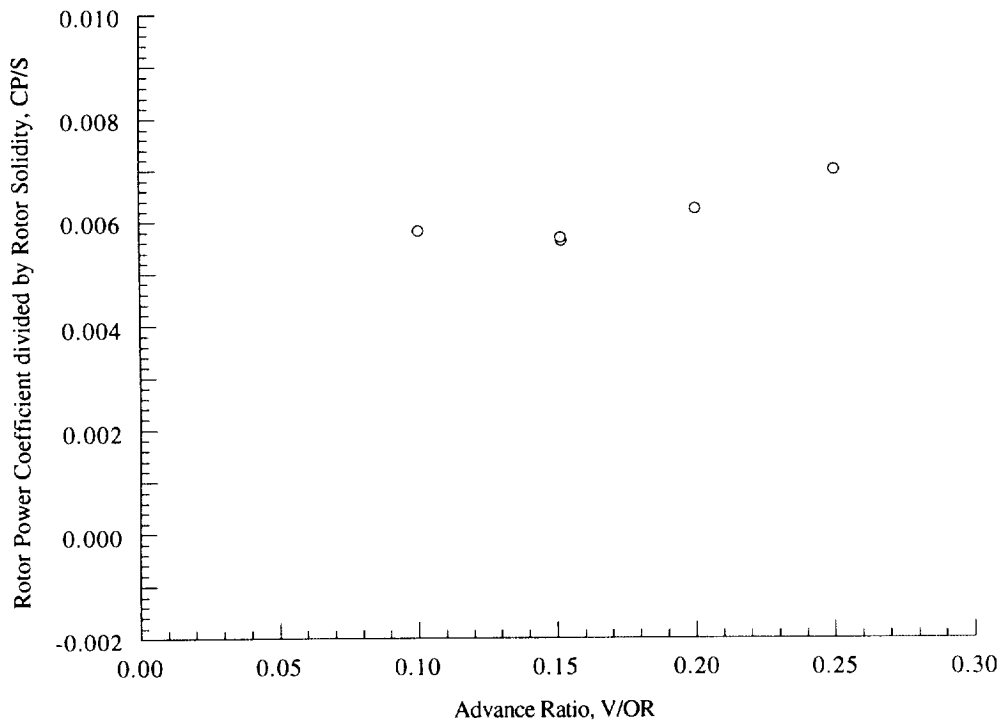

Figure 15(h). Rotor power coefficient as a function of advance ratio, $\alpha_S = -10$ deg, $C_T/\sigma = 0.090$.

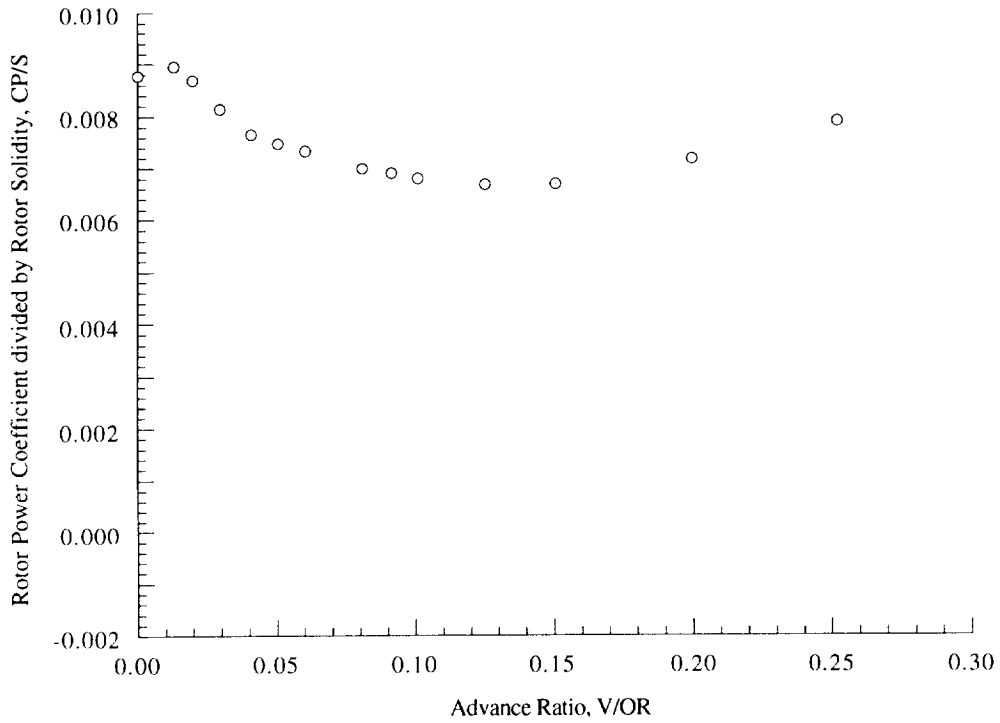

Figure 15(i). Rotor power coefficient as a function of advance ratio, $\alpha_S = -10$ deg, $C_T/\sigma = 0.100$.

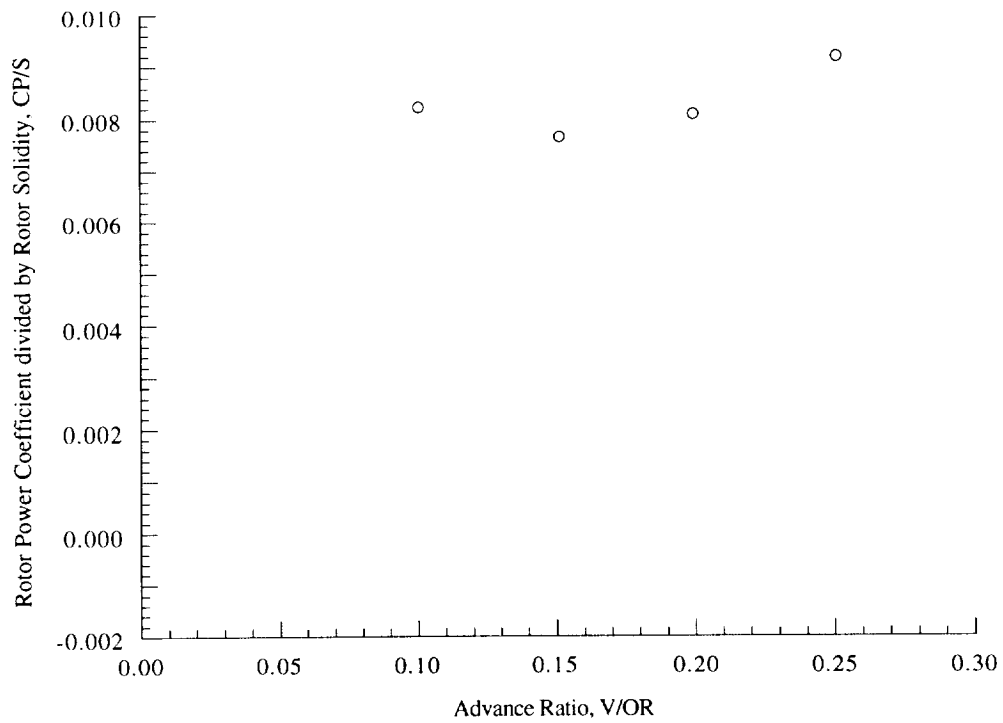

Figure 15(j). Rotor power coefficient as a function of advance ratio, $\alpha_S = -10$ deg, $C_T/\sigma = 0.110$.

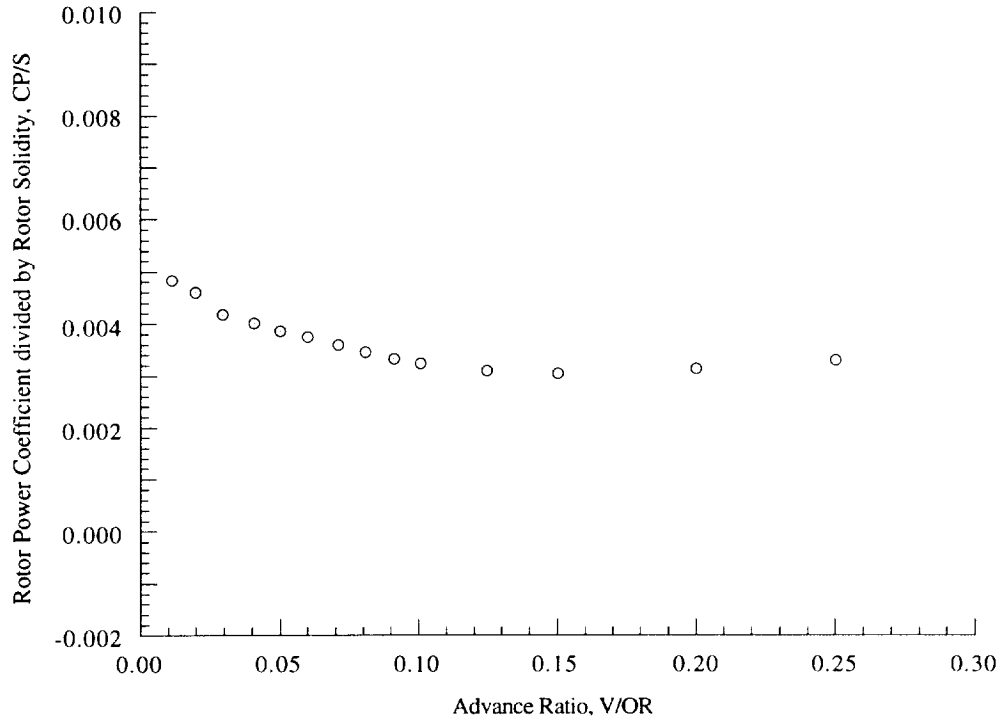

Figure 16(a). Rotor power coefficient as a function of advance ratio, $\alpha_S = -5$ deg, $C_T/\sigma = 0.065$.

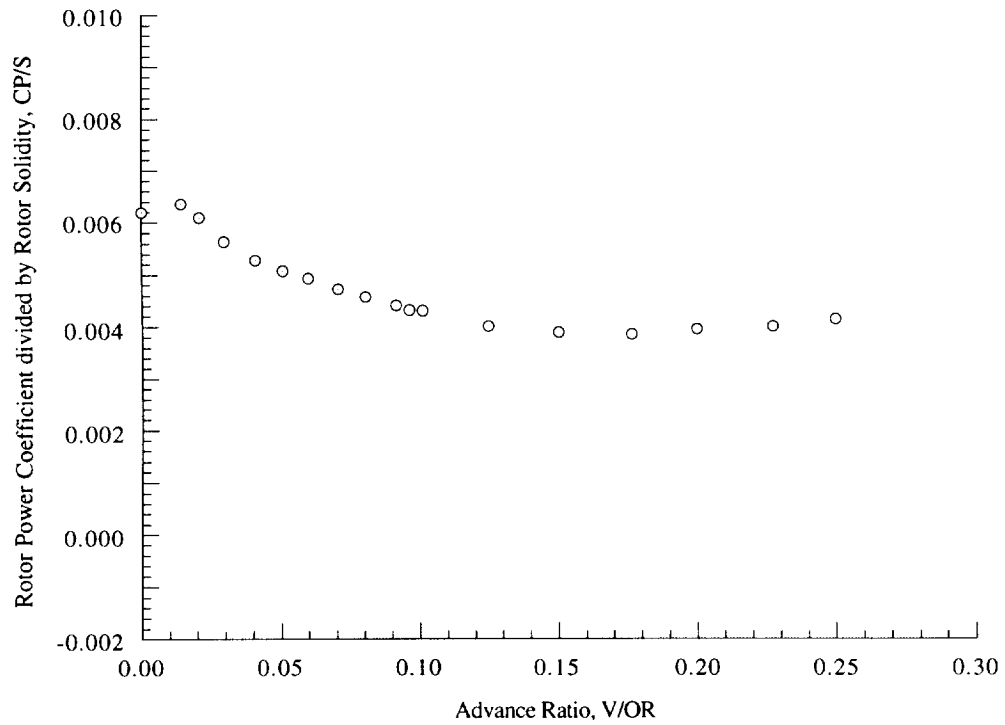

Figure 16(b). Rotor power coefficient as a function of advance ratio, $\alpha_S = -5$ deg, $C_T/\sigma = 0.080$.

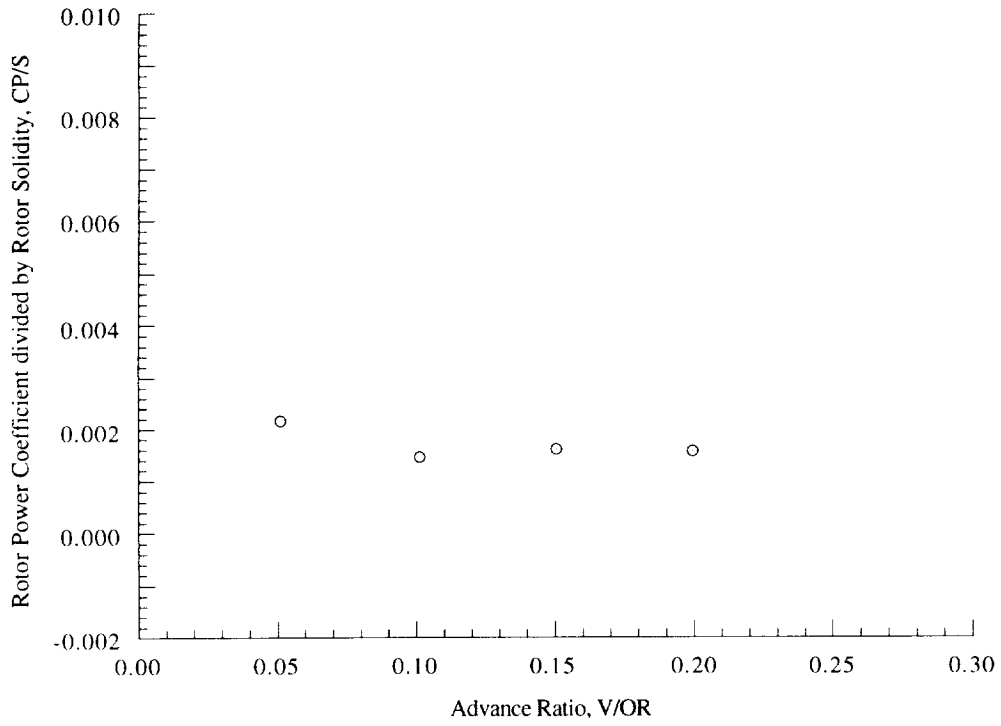

Figure 17(a). Rotor power coefficient as a function of advance ratio, $\alpha_S = -2$ deg, $C_T/\sigma = 0.040$.

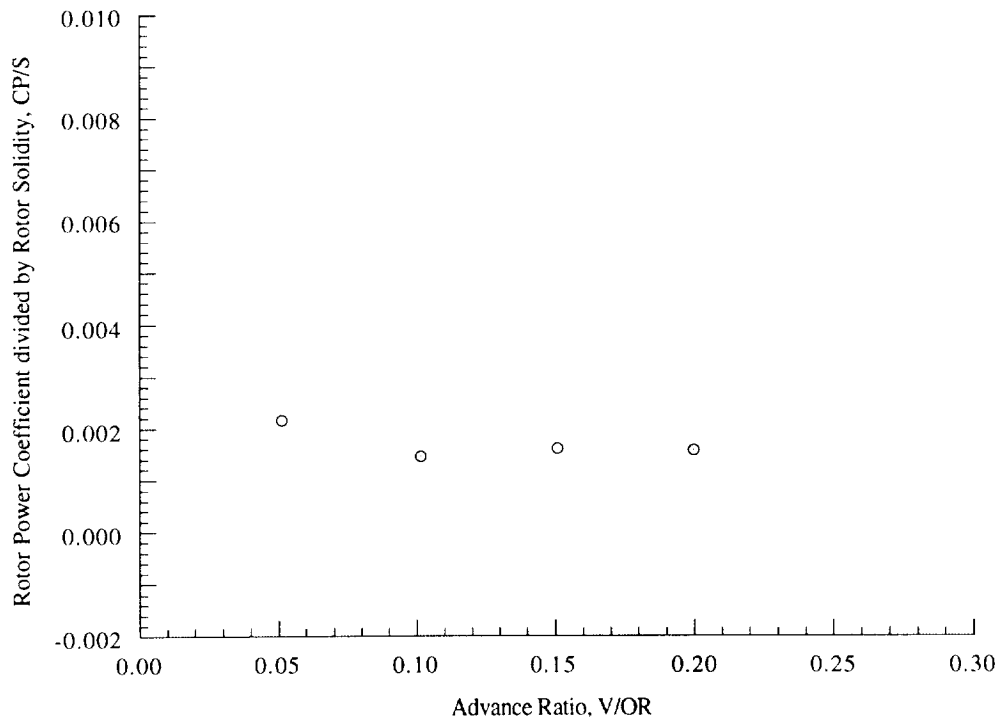

Figure 17(b). Rotor power coefficient as a function of advance ratio, $\alpha_S = -2$ deg, $C_T/\sigma = 0.050$.

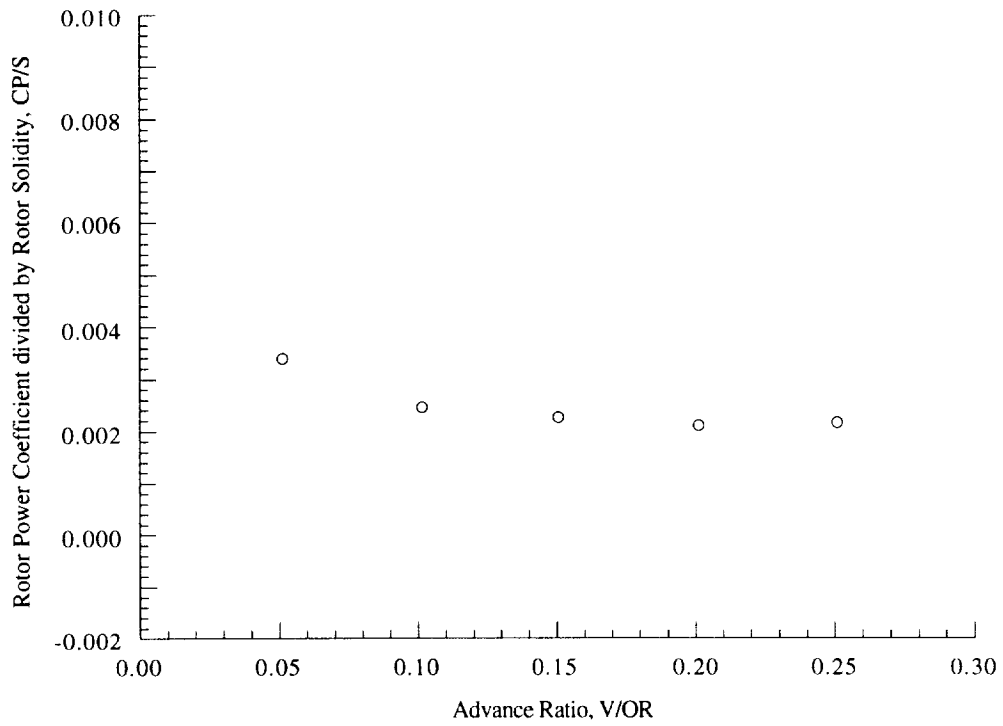

Figure 17(c). Rotor power coefficient as a function of advance ratio, $\alpha_S = -2$ deg, $C_T/\sigma = 0.060$.

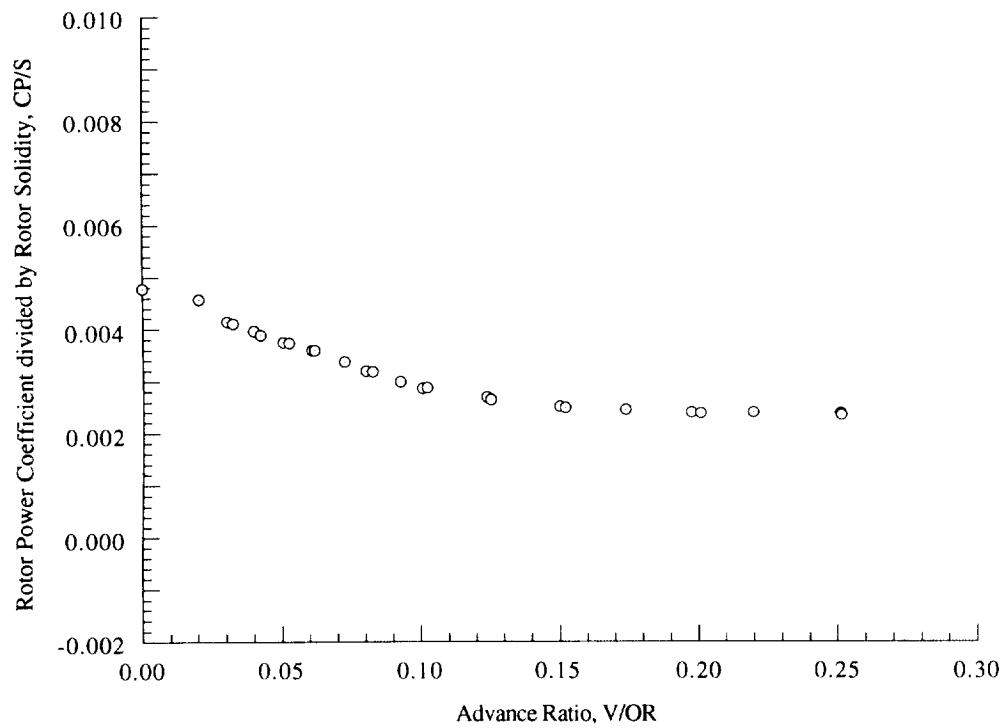

Figure 17(d). Rotor power coefficient as a function of advance ratio, $\alpha_S = -2$ deg, $C_T/\sigma = 0.065$.

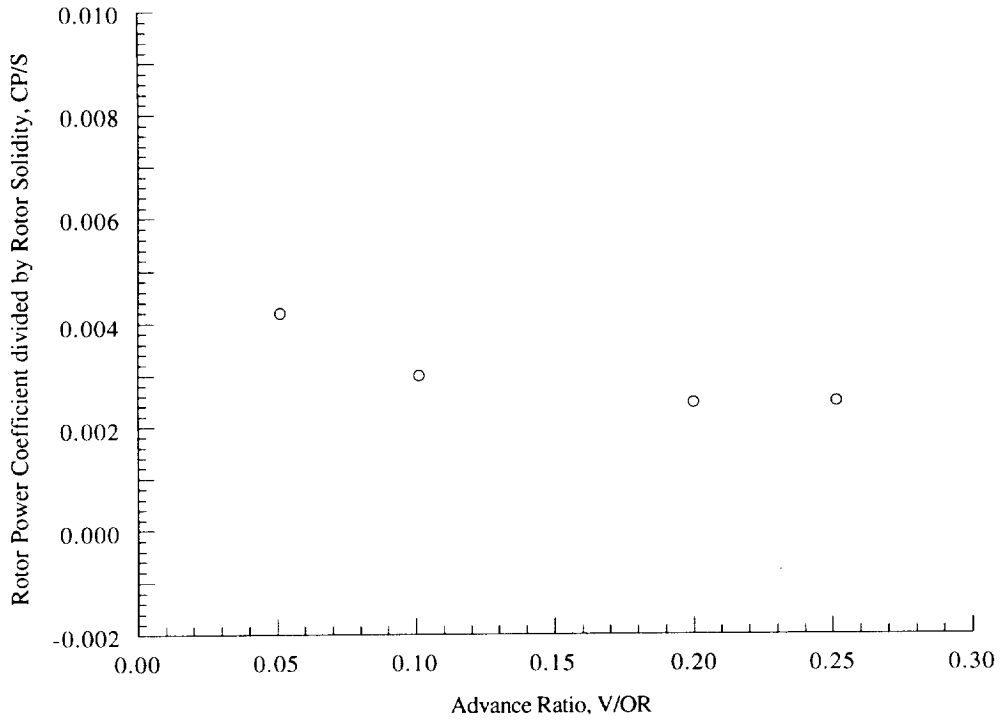

Figure 17(e). Rotor power coefficient as a function of advance ratio, $\alpha_S = -2$ deg, $C_T/\sigma = 0.070$.

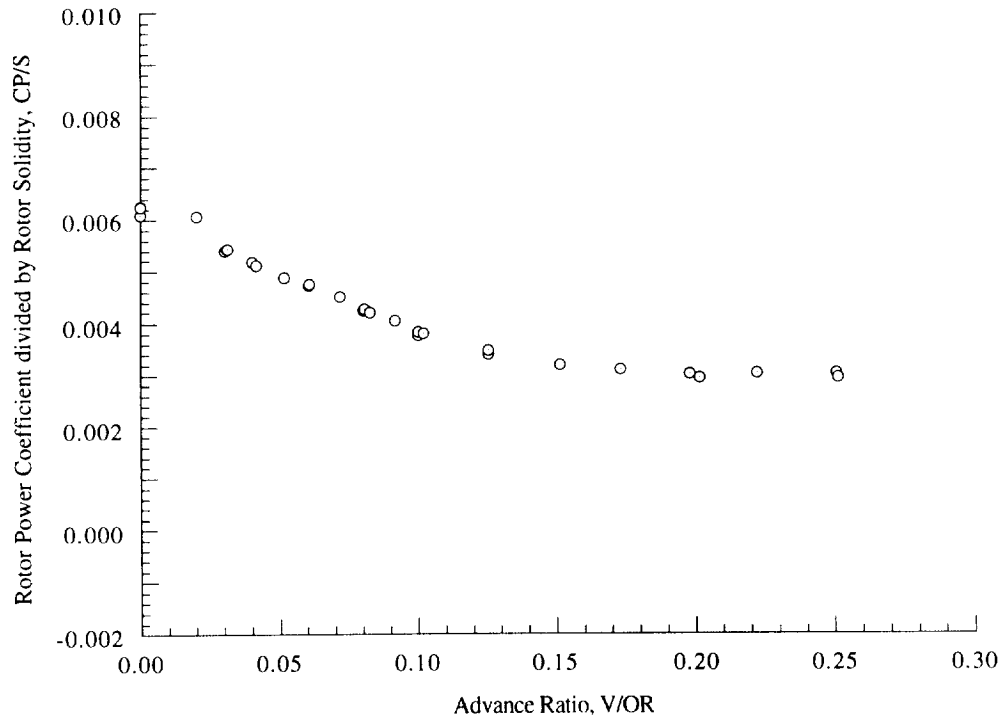

Figure 17(f). Rotor power coefficient as a function of advance ratio, $\alpha_S = -2$ deg, $C_T/\sigma = 0.080$.

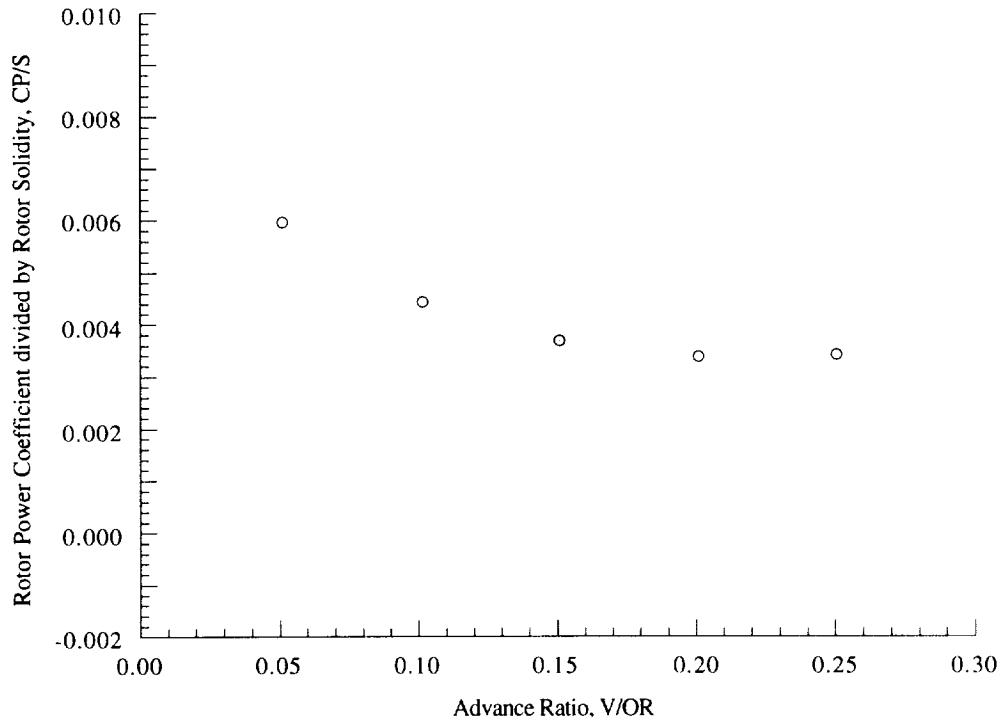

Figure 17(g). Rotor power coefficient as a function of advance ratio, $\alpha_S = -2$ deg, $C_T/\sigma = 0.090$.

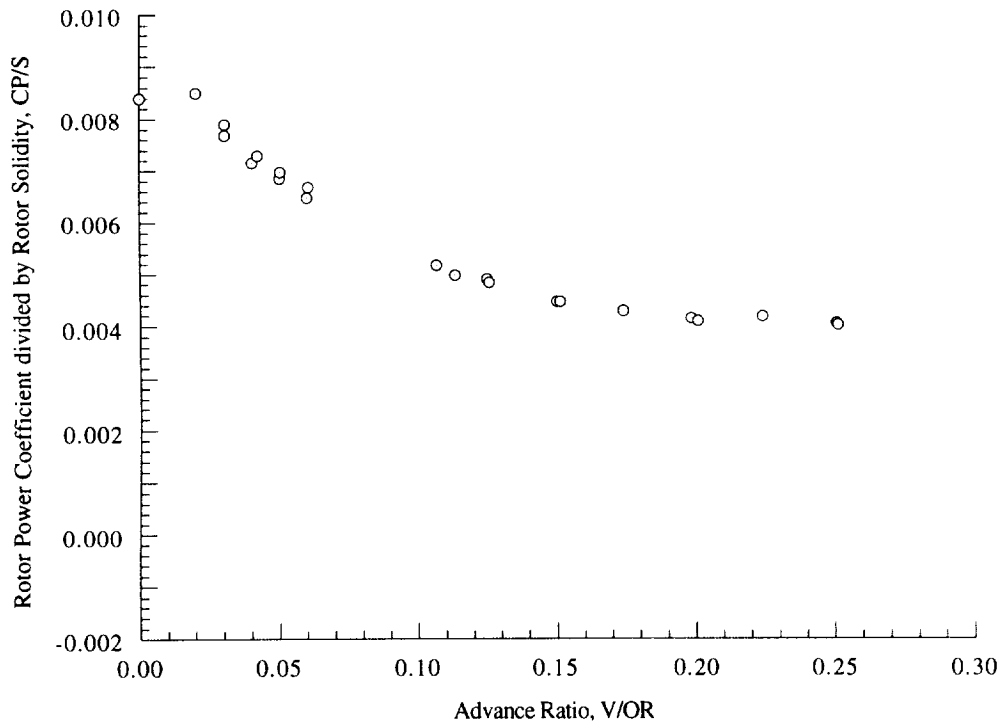

Figure 17(h). Rotor power coefficient as a function of advance ratio, $\alpha_S = -2$ deg, $C_T/\sigma = 0.100$.

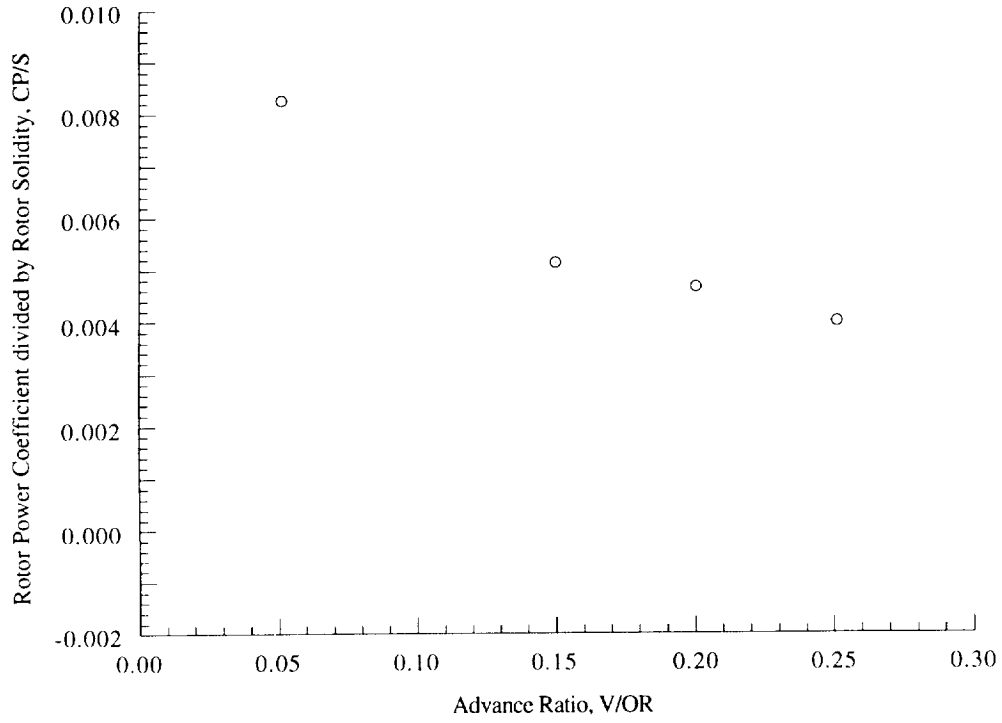

Figure 17(i). Rotor power coefficient as a function of advance ratio, $\alpha_S = -2$ deg, $C_T/\sigma = 0.110$.

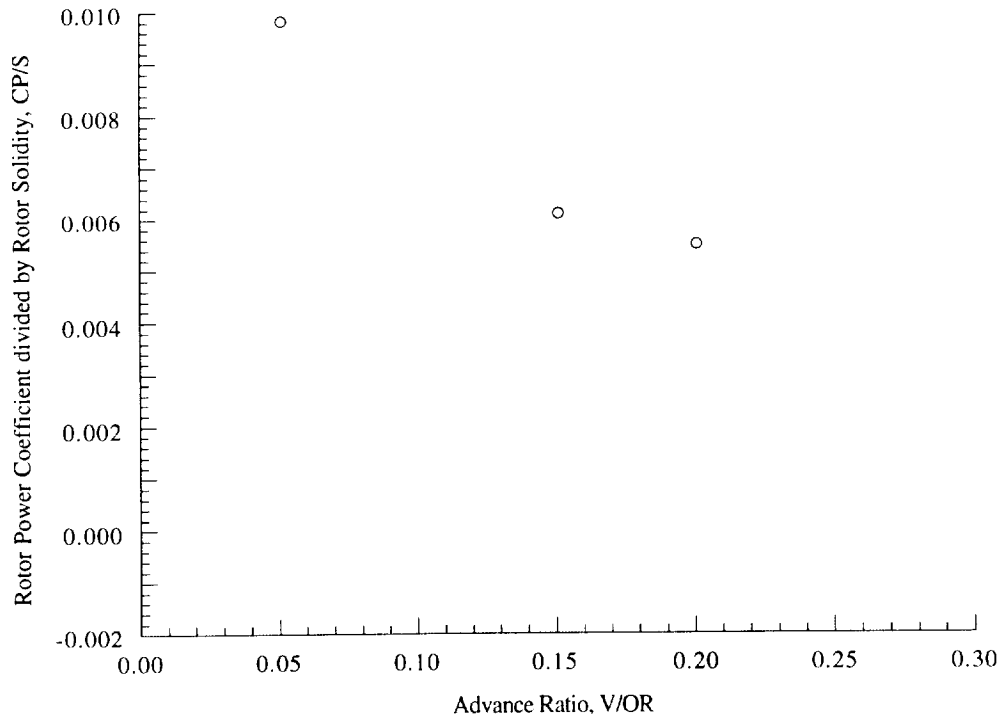

Figure 17(j). Rotor power coefficient as a function of advance ratio, $\alpha_S = -2$ deg, $C_T/\sigma = 0.120$.

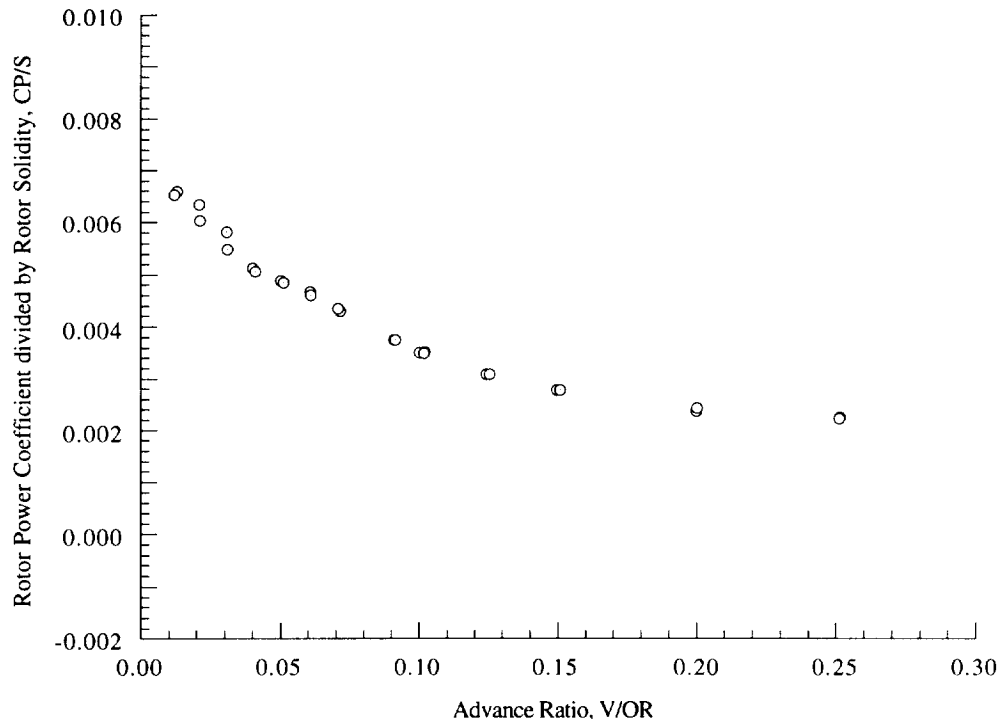

Figure 18(a). Rotor power coefficient as a function of advance ratio, $\alpha_S = 0$ deg, $C_T/\sigma = 0.080$.

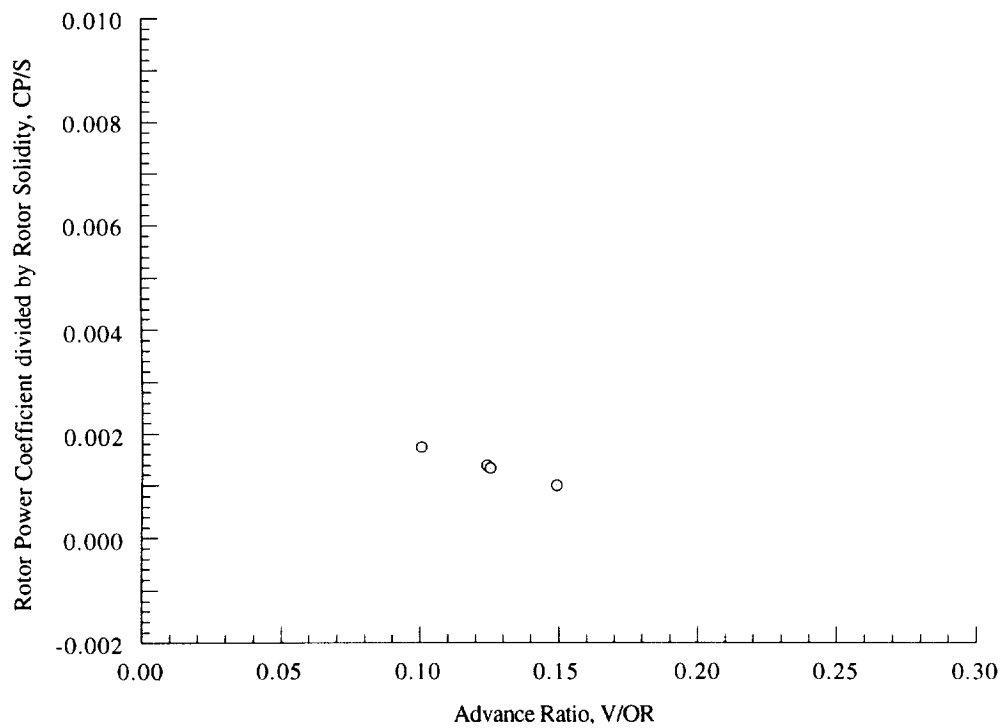

Figure 19(a). Rotor power coefficient as a function of advance ratio, $\alpha_S = 5$ deg, $C_T/\sigma = 0.060$.

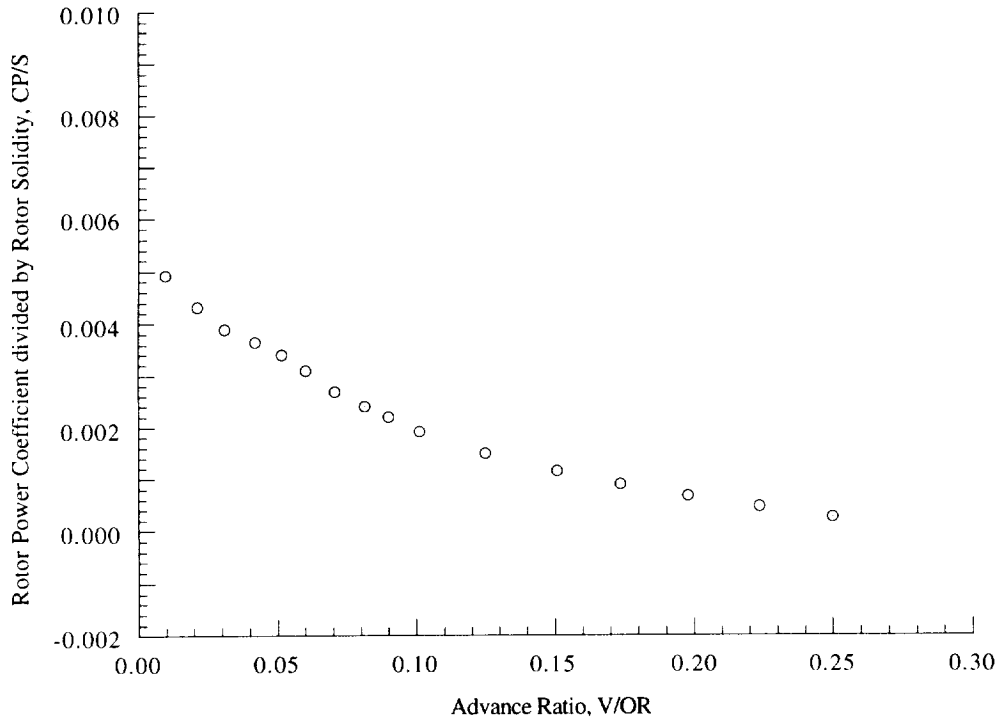

Figure 19(b). Rotor power coefficient as a function of advance ratio, $\alpha_S = 5$ deg, $C_T/\sigma = 0.065$.

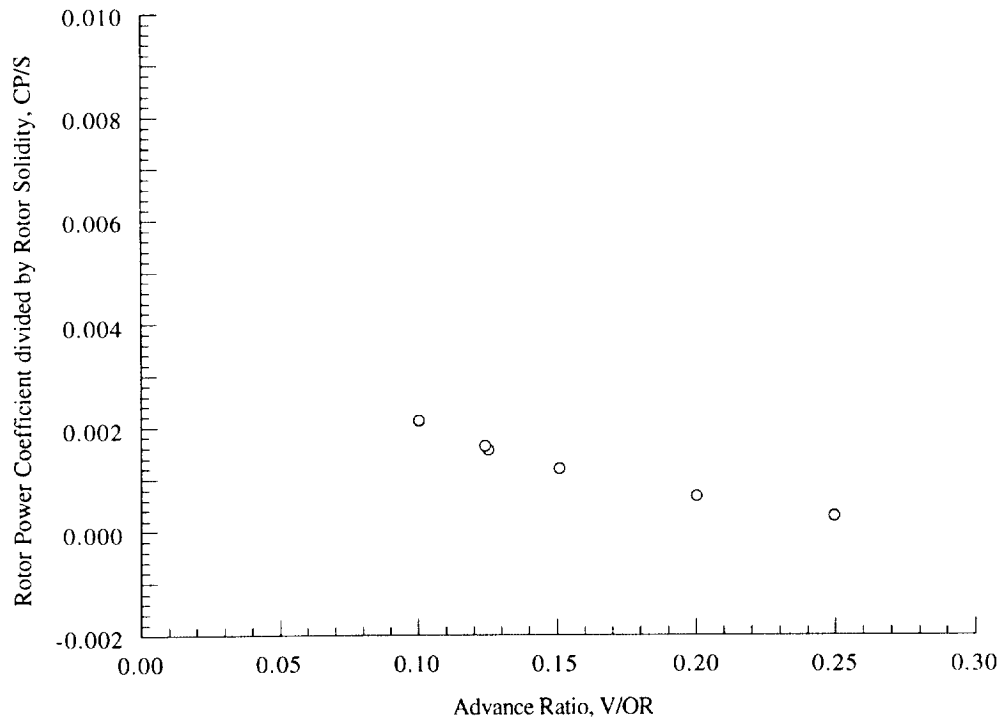

Figure 19(c). Rotor power coefficient as a function of advance ratio, $\alpha_S = 5$ deg, $C_T/\sigma = 0.070$.

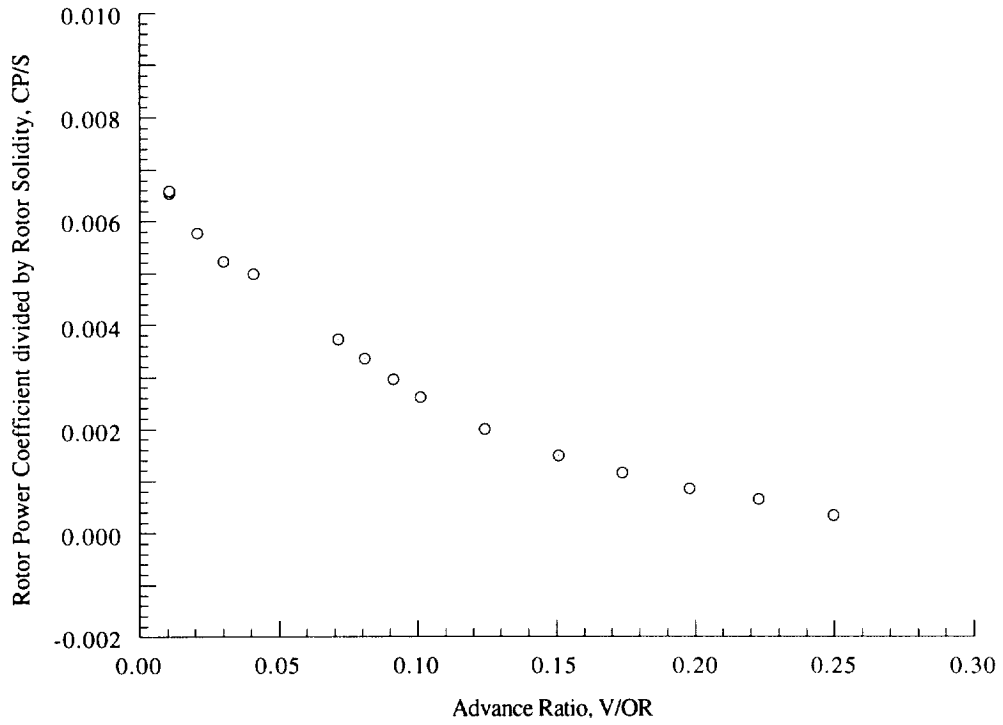

Figure 19(d). Rotor power coefficient as a function of advance ratio, $\alpha_S = 5$ deg, $C_T/\sigma = 0.080$.

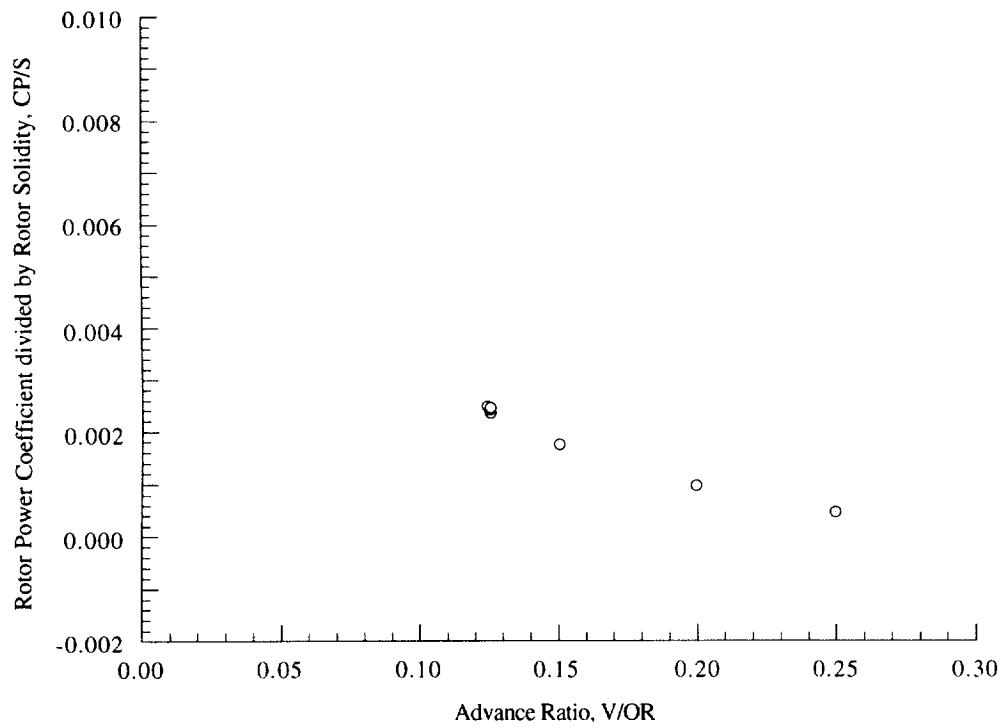

Figure 19(e). Rotor power coefficient as a function of advance ratio, $\alpha_S = 5$ deg, $C_T/\sigma = 0.090$.

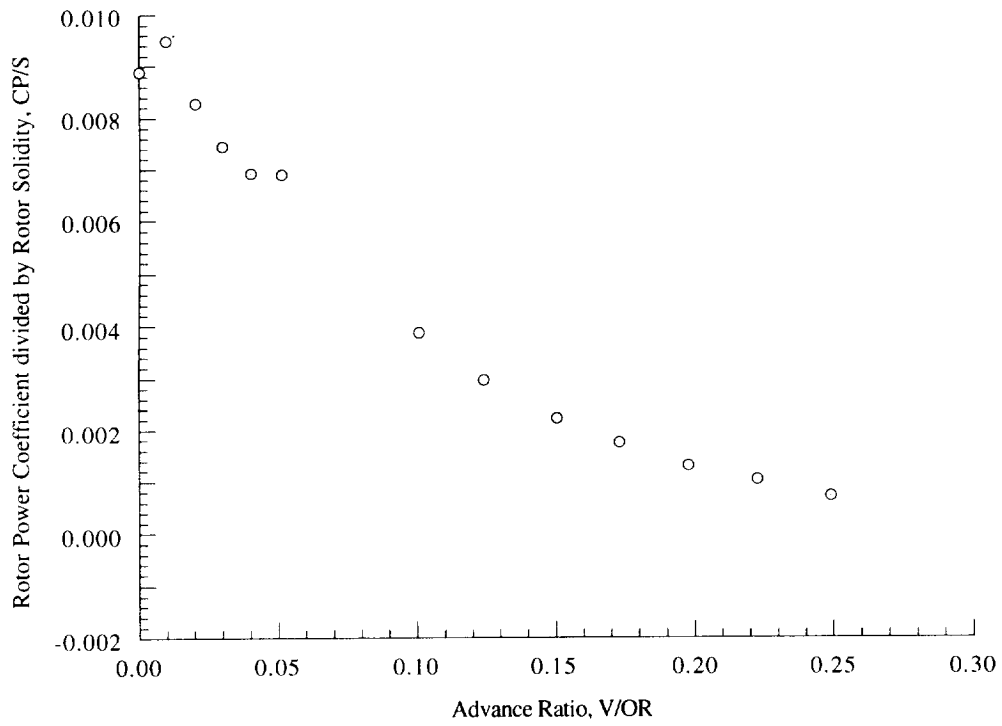

Figure 19(f). Rotor power coefficient as a function of advance ratio, $\alpha_S = 5$ deg, $C_T/\sigma = 0.100$.

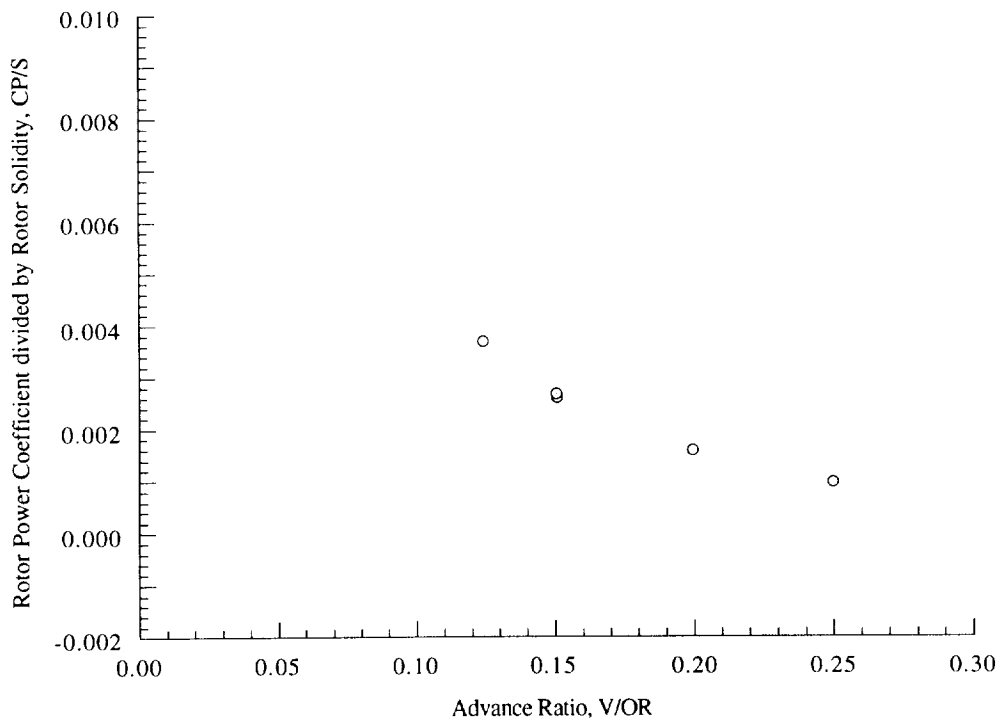

Figure 19(g). Rotor power coefficient as a function of advance ratio, $\alpha_S = 5$ deg, $C_T/\sigma = 0.110$.

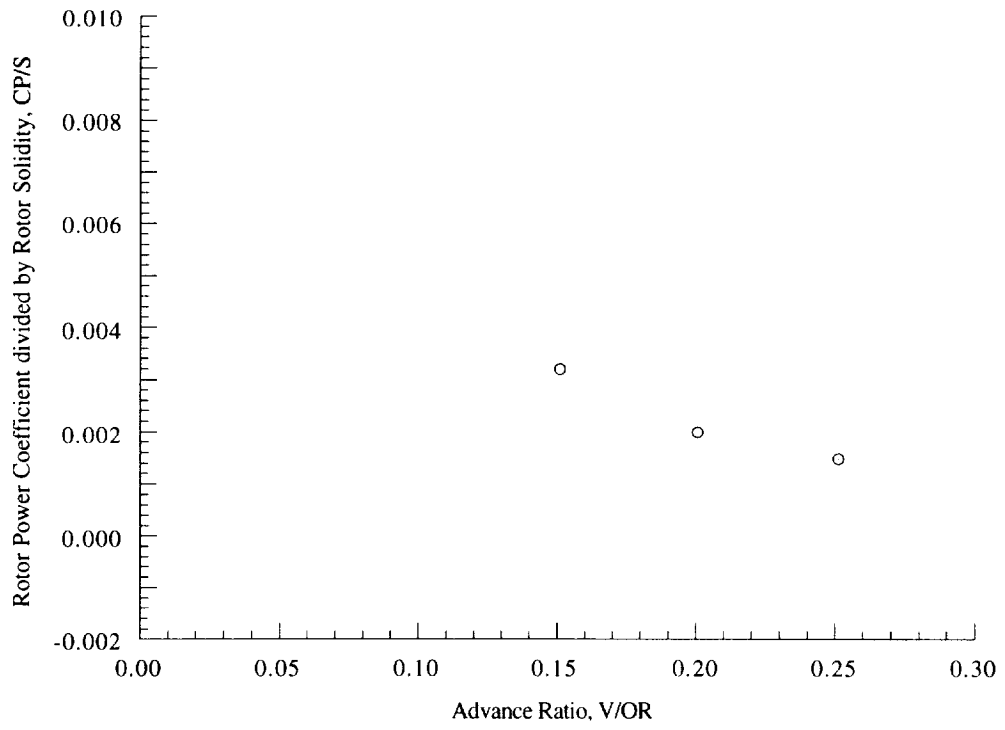

Figure 19(h). Rotor power coefficient as a function of advance ratio, $\alpha_S = 5$ deg, $C_T/\sigma = 0.120$.

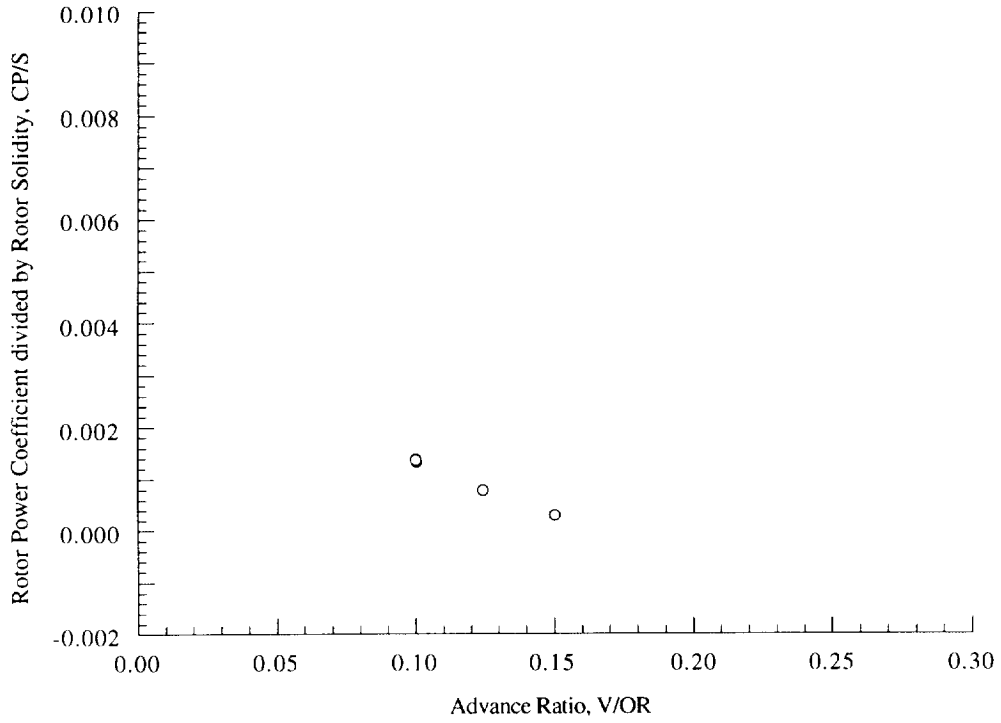

Figure 20(a). Rotor power coefficient as a function of advance ratio, $\alpha_S = 10$ deg, $C_T/\sigma = 0.070$.

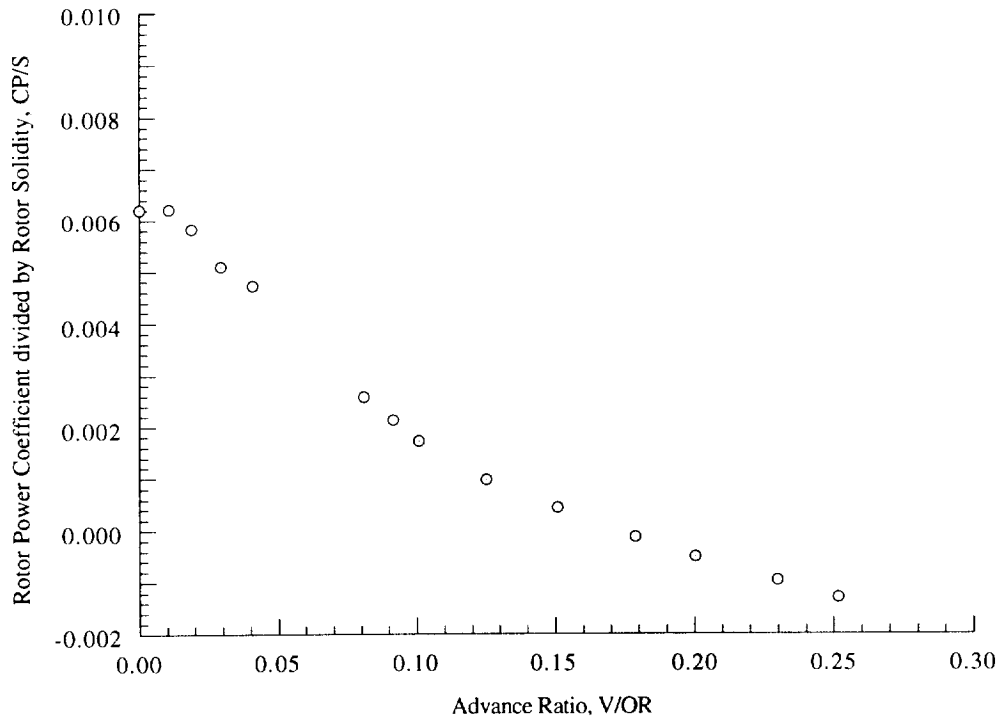

Figure 20(b). Rotor power coefficient as a function of advance ratio, $\alpha_S = 10$ deg, $C_T/\sigma = 0.080$.

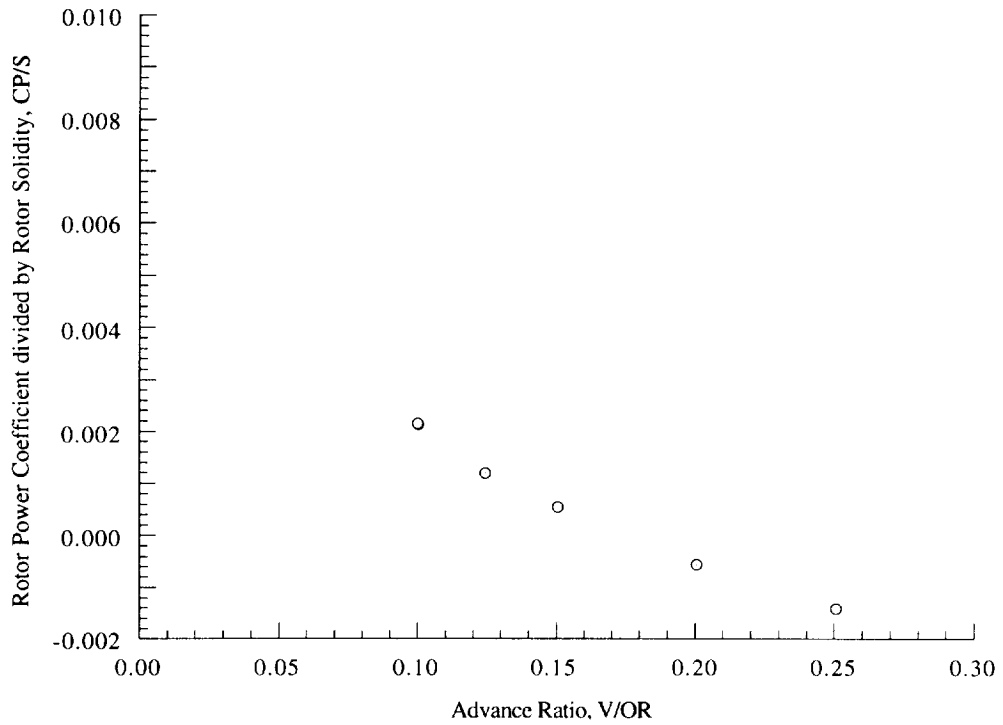

Figure 20(c). Rotor power coefficient as a function of advance ratio, $\alpha_S = 10$ deg, $C_T/\sigma = 0.090$.

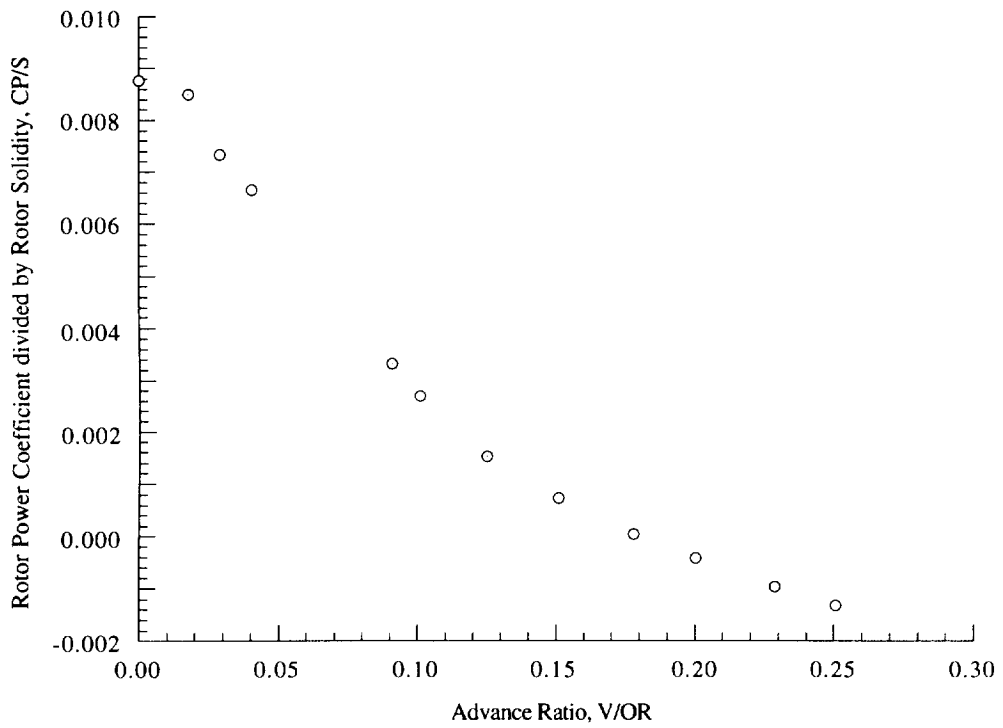

Figure 20(d). Rotor power coefficient as a function of advance ratio, $\alpha_S = 10$ deg, $C_T/\sigma = 0.100$.

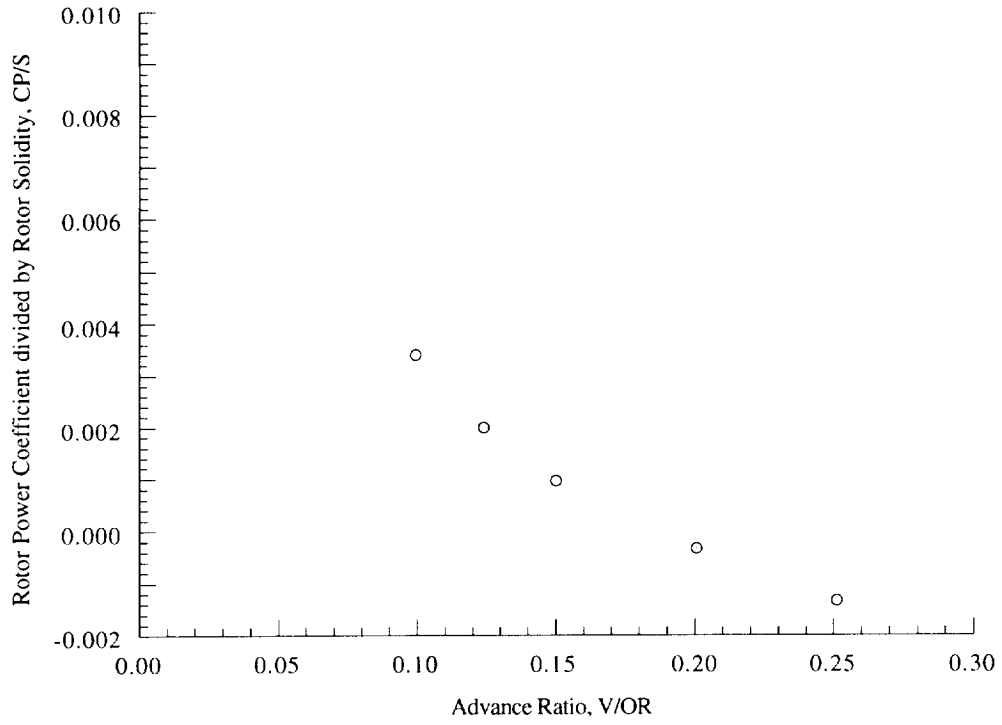

Figure 20(e). Rotor power coefficient as a function of advance ratio, $\alpha_S = 10$ deg, $C_T/\sigma = 0.110$.

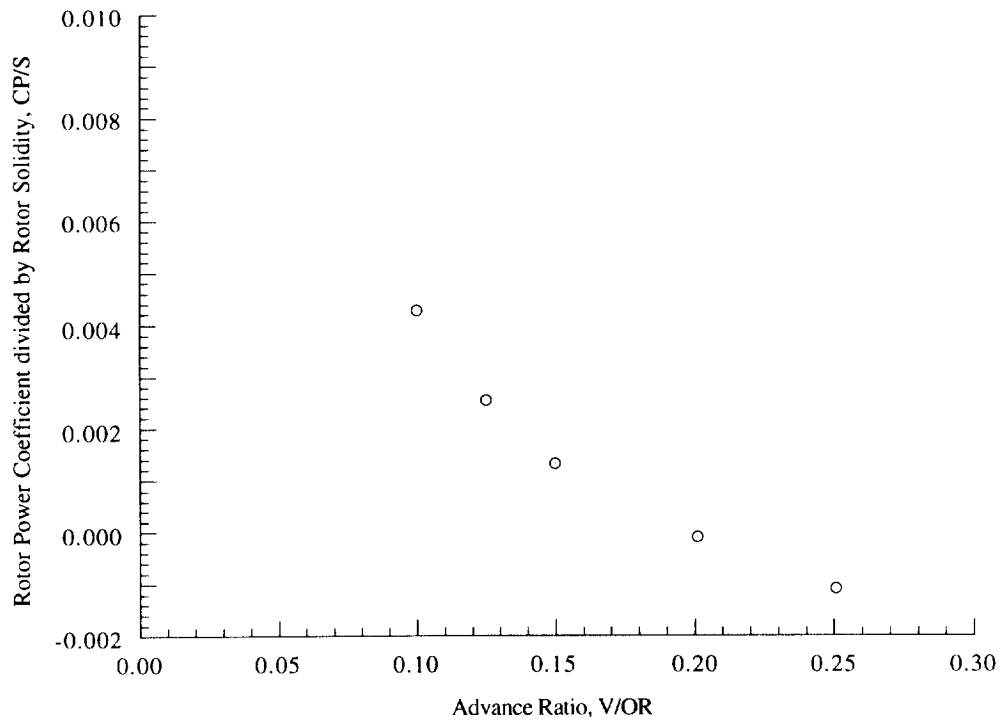

Figure 20(f). Rotor power coefficient as a function of advance ratio, $\alpha_S = 10$ deg, $C_T/\sigma = 0.120$.

APPENDIX A

**HOVER
PERFORMANCE DATA**

Hover Performance Data

Performance data for hover conditions with minimized flapping trim are presented in tabulated form in this appendix. Data runs are grouped in terms of shaft angle-of-attack, α_s . No wall or ground effect corrections have been applied to this data. Definitions of the measurements that are presented in this section are shown below. Identification of test conditions and its location within this appendix are presented following these definitions.

Nomenclature

A	rotor disk area, πR^2 , ft ²
ALFS,U , α_s	rotor shaft angle, positive aft of vertical, deg
A1	coefficient in the representation of rotor blade lateral cyclic pitch (fixed system measurement) $\theta = \text{THETA} - A1 \cos \psi - B1 \sin \psi$, deg
b	number of rotor blades
B1	coefficient in the representation of rotor blade longitudinal cyclic pitch (fixed system measurement) $\theta = \text{THETA} - A1 \cos \psi - B1 \sin \psi$, deg
BARO	atmospheric pressure, lb/ft ²
c	blade mean airfoil chord length, ft
CLRH/S	rotor lift force coefficient divided by rotor solidity, wind axis, positive up, $\text{LIFTH,C}/\rho(\Omega R)^2 S_R$
CLRHS/S	rotor lift force coefficient divided by rotor solidity, shaft axis, $\text{LIFTH,S}/\rho(\Omega R)^2 S_R$
CMXHS/S	rotor rolling moment coefficient divided by rotor solidity, shaft axis, $\text{ROLLH,S}/\rho S_R(\Omega R)^2 R$
CMYHS/S	rotor pitching moment coefficient divided by rotor solidity, shaft axis, $\text{PITCHH,S}/\rho S_R(\Omega R)^2 R$
CONING	mean flap angle, deg
CP	rotor power coefficient, $\text{POW}/\rho A(\Omega R)^3$
CP/S	rotor power coefficient divided by rotor solidity, $\text{POW}/\rho(\Omega R)^3 S_R$
CPO/S	rotor non-ideal power coefficient divided by rotor solidity, $\text{CP/S} - \text{CP/S ideal}$
C _s	speed of sound, ft/s
CTH	rotor thrust coefficient, perpendicular to rotor tip-path-plane, $\text{THRUST}/\rho A(\Omega R)^2$
CTH/S	rotor thrust coefficient divided by rotor solidity, $\text{THRUST}/\rho(\Omega R)^2 S_R$
CXRH/S	rotor propulsive force coefficient divided by rotor solidity, wind axis, positive forward, $-\text{DRAGH,C}/\rho(\Omega R)^2 S_R$
CXRHS/S	rotor propulsive force coefficient divided by rotor solidity, shaft axis, positive forward, $-\text{DRAGH,S}/\rho(\Omega R)^2 S_R$

CYRH/S	rotor side force coefficient divided by rotor solidity, wind axis, $SIDEH,C/\rho(\Omega R)^2 S_R$
CYRHS/S	rotor side force coefficient divided by rotor solidity, shaft axis, $SIDEH,S/\rho(\Omega R)^2 S_R$
DRAGH,C	rotor wind-axis drag, positive downstream, lb
DRAGH,S	rotor shaft-axis drag, positive downstream, lb
FMERIT	Figure of Merit, $CTH^{3/2}/CP*(2)^{1/2}$
HFORCE	rotor propulsive force, shaft axis, positive forward, lb
HP	rotor horsepower, $POW/550$
LIFTH,C	rotor wind-axis lift, positive up, lb
LIFTH,S	rotor shaft-axis lift, positive up, lb
MTUN	tunnel Mach number, V/CS
MTIP	rotor rotational tip Mach number, $\Omega R/CS$
OMEG*R	rotor tip speed, ΩR , ft/sec
PITCHH,S	rotor shaft-axis pitching moment, positive nose up, ft-lb
POINT	data point number
POW	rotor shaft power, $TORQ,C * \Omega$, ft-lb/s
QPSF	free-stream dynamic pressure, lb/ft^2
R	rotor radius, ft
RHO, ρ	free-stream air density, ρ , slug/ft ³
ROLLH,S	rotor shaft-axis rolling moment, positive right wing down, ft-lb
RPM	rotor rotation rate, rev/min.
RUN	data run number
SIDEH,C	rotor side force, wind-axis, positive right, lb
SIDEH,S	rotor side force, shaft-axis, positive right, lb
S_R	rotor blade area, bcR , ft ²
THETA	rotor collective(fixed system measurments), deg
THRUST	rotor thrust, perpendicular to tip-path-plane, positive up, lb
TORQ,C , TQ	flexcoupling or rotor shaft torque, ft-lb

TTEMPF	tunnel air temp, F°
V/OR, μ	rotor advance ratio, $V/\Omega R$
V	free-stream velocity, ft/s
VKTS	free-stream velocity, kt
YAW	relative model yaw position to free-stream velocity, positive yaw right, deg
θ	blade pitch at specific blade azimuth position (ψ), deg
σ	rotor solidity, $bc/\pi R$
ψ	rotor blade azimuth angle measured from downwind position in direction of rotation, deg
Ω	rotor rotational speed, rad/s

Hover Performance Data Index

YAW deg	ALFS,U deg	RUN	PTS	CTH/S	DATA LOCATION
0	-15	43	9-15	.031-->.090	A-8 to A-9
0	-15	54	12-20	.030-->.108	A-9 to A-10
0	-15	62	5-15	.030-->.109	A-10 to A-12
-----	-----	-----	-----	-----	-----
0	-10	20	35	.0183	A-12
0	-10	21	12-22,32	.018-->.070	A-12 to A-14
0	-10	45	15,16	.031,.070	A-14
0	-10	62	16-24	.029-->.108	A-15 to A-16
-----	-----	-----	-----	-----	-----
0	-5	62	25-30	.031-->.078	A-16 to A-17
-----	-----	-----	-----	-----	-----
0	-2	20	36	.0177	A-17
0	-2	44	24,25	.041, .069	A-17
0	-2	62	31-36	.031-->.078	A-18
-----	-----	-----	-----	-----	-----
0	0	33	17-23	.018-->.078	A-19 to A-20
0	0	36	34	.088	A-20
0	0	37	32	.086	A-20
0	0	39	34	.061	A-20
0	0	42	5-8	.030-->.051	A-20 to A-21

**Hover Performance Data Index
(Continued)**

YAW deg	ALFS,U deg	RUN	PTS	CTH/S	DATA LOCATION
0	+5	43	27-31	.030-->.071	A-21 to A-22
0	+5	46	16-18	.031,.070,.102	A-22
-----	-----	-----	-----	-----	-----
0	+10	41	30-32	.100,.069,.019	A-22 to A-23
0	+10	43	24-26	.030-->.051	A-23
0	-----	-----	-----	-----	-----
0	+15	43	16-23	.031-->.099	A-23to A-24
0	+15	54	5-11	.029-->.090	A-25 to A-26
	-----	-----	-----	-----	-----
90	+15	52	6-15	.030-->.118	A-26 to A-27
90	+15	52	16-24	.035-->.115	A-27 to A-29

RUN POINT	V/OR VKTS ALFS,U	MTUN QPSF BARO RHO	MTIP RPM OMEG*R TTEMPF	THETA A1 B1 CONING	LIFTH,C DRAGH,C SIDEH,C	PITCHH,S ROLLH,S TORQ,C HFORCE	CLRH/S CXRH/S CYRH/S	CLRHS/S CXRHS/S CYRHS/S	CMYHS/S CMXHS/S	THRUST POW HP	CTH/S CP/S CPO/S FMERIT
43	0	0	0.604	4.1	3707	40	0.030001	0.031105	0.000015	3844	0.031105
9	0	0	292	0.3	-1015	-46	0.008216	0.000171	-0.000017	187971	0.002261
	-15	14.8	672.7	0.1	19	6147	0.00015	0.00015		342	0.0012
		0.002401	55.8	2.3		-21					0.4692
43	0	0	0.605	5.4	4850	223	0.039098	0.040513	0.000082	5026	0.040513
10	0	0	292.5	0.4	-1317	-5	0.010614	0.000133	-0.000002	238277	0.00285
	-15	14.806	673.9	0.1	22	7779	0.000178	0.000178		433	0.001273
		0.002402	55.8	2.7		-16					0.5532
43	0	0	0.606	6.6	6143	76	0.049446	0.051288	0.000028	6371	0.051288
11	0	0	292.7	0.4	-1693	-105	0.013626	0.000364	-0.000039	307009	0.003665
	-15	14.807	674.3	0.3	23	10016	0.000181	0.000181		558	0.001419
		0.002402	55.8	3.3		-45					0.6129
43	0	0	0.606	8	7366	237	0.059165	0.06131	0.000087	7633	0.06131
12	0	0	293	0.5	-2001	-79	0.016074	0.000203	-0.000029	382651	0.004553
	-15.01	14.809	675	0.2	39	12471	0.00031	0.00031		696	0.001617
		0.002402	55.8	3.8		-25					0.6448
43	0	0	0.605	9	8469	239	0.068373	0.07082	0.000088	8772	0.07082
13	0	0	292.3	0.5	-2286	10	0.018456	0.000131	0.000004	452846	0.005429
	-15	14.804	673.4	0.1	45	14794	0.000362	0.000362		823	0.001784
		0.002401	55.8	4.3		-16					0.6713
43	0	0	0.606	10.1	9516	293	0.07668	0.079458	0.000107	9861	0.079458
14	0	0	292.5	0.7	-2585	-54	0.02083	0.000274	-0.00002	535762	0.006406
	-15	14.809	673.9	0.1	60	17491	0.000483	0.000483		974	0.002075
		0.002403	55.7	4.7		-34					0.6761

RUN POINT	V/OR VKTS ALFS,U	MTUN QPSF BARO RHO	MTIP RPM OMEG*R TTEMPF	THETA A1 B1 CONING	LIFTH,C DRAGH,C SIDEH,C	PITCHH,S ROLLH,S TORQ,C HFORCE	CLRH/S CXRH/S CYRH/S	CLRHS/S CXRHS/S CYRHS/S	CMYHS/S CMXHS/S	THRUST POW HP	CTH/S CP/S CPO/S FMERIT
43	0	0	0.607	11.3	10774	7	0.086383	0.089598	0.000003	11175	0.089598
15	0	0	293.3	0.7	-2968	7	0.023793	0.000624	0.000002	634214	0.007525
	-15	14.802	675.7	0.5	78	20649	0.000623	0.000623		1153	0.002338
		0.002402	55.7	5.2		-78					0.6892
54	0.004	0.003	0.605	4	3549	-183	0.028688	0.029637	-0.000067	3667	0.029637
12	1.7	0.01	293.2	0.1	-921	-390	0.007444	-0.000234	-0.000143	183634	0.002197
	-15	14.777	675.5	0	44	5981	0.000356	0.000356		334	0.001211
		0.002384	58.3	2.1		29					0.449
54	0	0	0.603	5.2	4659	-152	0.037939	0.039221	-0.000056	4817	0.039221
13	0	0	292.1	0.1	-1222	-469	0.009948	-0.00021	-0.000174	234056	0.002832
	-15	14.777	673	0	45	7652	0.000367	0.000367		426	0.00133
		0.002384	58.2	2.6		26					0.5304
54	0	0	0.606	6.6	6031	-70	0.048633	0.050263	-0.000026	6233	0.050263
14	0	0	293.5	0.2	-1575	-387	0.012702	-0.000318	-0.000142	303360	0.003618
	-15	14.777	676.2	0.1	48	9870	0.000384	0.000384		552	0.001438
		0.002385	58.1	3.2		39					0.6024
54	0	0	0.605	7.6	6910	-2	0.055945	0.057836	-0.000001	7143	0.057836
15	0	0	292.9	0.2	-1812	-324	0.014672	-0.000307	-0.000119	358847	0.004306
	-15	14.777	674.8	0.1	56	11699	0.000454	0.000454		652	0.001616
		0.002385	58.1	3.6		38					0.6247
54	0	0	0.603	8.9	8194	-338	0.066728	0.069125	-0.000125	8489	0.069125
16	0	0	292	0.2	-2216	-435	0.018046	0.00016	-0.000161	442030	0.005351
	-15	14.777	672.7	0.3	63	14456	0.000512	0.000512		804	0.001836
		0.002386	57.9	4.2		-20					0.6568

RUN POINT	V/OR VKTS ALFS,U	MTUN QPSF BARO RHO	MTIP RPM OMEG*R TTEMPF	THETA A1 B1 CONING	LIFTH,C DRAGH,C SIDEH,C	PITCHH,S ROLLH,S TORQ,C HFORCE	CLRH/S CXRH/S CYRH/S	CLRHS/S CXRHS/S CYRHS/S	CMYHS/S CMXHS/S	THRUST POW HP	CTH/S CP/S CPO/S FMERIT
54	0	0	0.607	10.2	9576	-138	0.076991	0.079657	-0.00005	9907	0.079657
17	0	0	293.8	0.6	-2542	-232	0.020436	-0.000187	-0.000085	548455	0.006515
	-15	14.777	676.9	0.1	120	17826	0.000967	0.000967		997	0.002167
		0.002387	57.7	4.6		23					0.6673
54	0	0	0.607	11	10483	9	0.084394	0.087317	0.000003	10846	0.087317
18	0	0	293.6	0.6	-2782	-299	0.022401	-0.000205	-0.000109	619854	0.007378
	-15	14.778	676.4	0.1	100	20161	0.000803	0.000803		1127	0.002388
		0.002387	57.7	5.1		25					0.6763
54	0	0	0.608	12.4	11863	-44	0.094944	0.098193	-0.000016	12268	0.098193
19	0	0	294.4	0.9	-3130	-17	0.02505	-0.000377	-0.000006	739569	0.008727
	-15	14.778	678.2	0.2	174	23989	0.00139	0.00139		1345	0.002777
		0.002388	57.5	5.6		47					0.6818
54	0	0	0.604	13.5	12890	39	0.104572	0.108116	0.000014	13326	0.108116
20	0	0	292.4	0.9	-3385	-41	0.027463	-0.000538	-0.000015	836250	0.010071
	-15	14.779	673.6	0.3	152	27311	0.001234	0.001234		1520	0.003196
		0.002388	57.5	6.1		66					0.6826
62	0.004	0.003	0.605	4	3537	-2	0.028674	0.029674	-0.000001	3660	0.029674
5	1.7	0.01	293.6	-0.1	-942	-35	0.007638	-0.000044	-0.000013	184204	0.002208
	-15	14.79	676.4	0.1	-1	5991	-0.000011	-0.000011		335	0.001219
		0.00237	61.1	2.6		5					0.4477
62	0	0	0.606	5.3	4724	-7	0.03817	0.039509	-0.000003	4889	0.039509
6	0	0	294.1	0	-1262	-155	0.010199	-0.000028	-0.000057	237970	0.002838
	-15	14.79	677.6	-0.1	10	7727	0.000081	0.000081		433	0.001319
		0.00237	61.1	3		3					0.5351

RUN POINT	V/OR VKTS ALFS,U	MTUN QPSF BARO RHO	MTIP RPM OMEG*R TTEMPF	THETA A1 B1 CONING	LIFTH,C DRAGH,C SIDEH,C	PITCHH,S ROLLH,S TORQ,C HFORCE	CLRH/S CXRH/S CYRH/S	CLRHS/S CXRHS/S CYRHS/S	CMYHS/S CMXHS/S	THRUST POW HP	CTH/S CP/S CPO/S FMERIT
62	0	0	0.605	6.6	5913	161	0.047843	0.049523	0.000059	6121	0.049523
7	0	0	293.9	0.5	-1581	-56	0.012791	-0.000028	-0.000021	301658	0.003605
	-15	14.79	677.1	0	34	9801	0.000276	0.000276		548	0.001473
		0.00237	61.1	3.7		3					0.5912
62	0	0	0.611	7.7	6924	63	0.05501	0.056972	0.000023	7171	0.056972
8	0	0	296.6	0.5	-1866	111	0.014826	0.000083	0.00004	368507	0.004285
	-15	14.789	683.3	0.1	61	11864	0.000482	0.000482		670	0.001655
		0.00237	61.1	4		-10					0.6138
62	0	0	0.605	9.1	8415	152	0.068089	0.070525	0.000056	8716	0.070525
9	0	0	293.9	0.7	-2271	-50	0.018377	0.000128	-0.000019	462912	0.005532
	-15	14.79	677.1	0.1	61	15041	0.000491	0.000491		842	0.001909
		0.00237	61.1	4.6		-16					0.6548
62	0	0	0.606	10.1	9249	203	0.07453	0.07719	0.000074	9579	0.07719
10	0	0	294.5	0.7	-2493	-137	0.020088	0.000114	-0.00005	535409	0.006359
	-15	14.789	678.5	0.1	63	17361	0.000505	0.000505		973	0.002212
		0.00237	61.1	5.1		-14					0.6522
62	0	0	0.605	11.2	10372	-91	0.08409	0.087186	-0.000034	10754	0.087186
11	0	0	293.6	0.9	-2841	31	0.023033	0.000484	0.000012	621477	0.007449
	-15	14.79	676.4	0.3	106	20213	0.000858	0.000858		1130	0.00247
		0.00237	61.1	5.5		-60					0.6684
62	0	0	0.607	12	11499	0	0.092605	0.095925	0	11911	0.095925
12	0	0	294.6	0.8	-3107	57	0.02502	0.0002	0.000021	706024	0.008377
	-15	14.791	678.7	0.2	91	22885	0.000733	0.000733		1284	0.002632
		0.00237	61.2	5.9		-25					0.6858

RUN POINT	V/OR VKTS ALFS,U	MTUN QPSF BARO RHO	MTIP RPM OMEG*R TTEMPF	THETA A1 B1 CONING	LIFTH,C DRAGH,C SIDEH,C	PITCHH,S ROLLH,S TORQ,C HFORCE	CLRH/S CXRH/S CYRH/S	CLRHS/S CXRHS/S CYRHS/S	CMYHS/S CMXHS/S	THRUST POW HP	CTH/S CP/S CPO/S FMERIT
62	0	0	0.605	13.6	12767	180	0.103472	0.107165	0.000066	13223	0.107165
13	0	0	293.7	0.9	-3441	-11	0.02789	0.000159	-0.000004	841757	0.010082
	-15	14.791	676.6	0.4	93	27369	0.000756	0.000756		1530	0.003298
		0.002369	61.3	6.4		-20					0.6729
62	0	0	0.605	13.6	13037	-20	0.10559	0.109403	-0.000008	13507	0.109403
14	0	0	293.7	0.9	-3535	222	0.028634	0.00033	0.000082	851296	0.01019
	-15	14.794	676.6	0.5	136	27679	0.001099	0.001099		1548	0.003192
		0.002371	61.1	6.4		-41					0.6867
62	0	0	0.605	10.5	9661	231	0.07815	0.081048	0.000085	10020	0.081048
15	0	0	293.9	0.9	-2656	-53	0.021485	0.000526	-0.00002	556389	0.006647
	-15	14.793	677.1	0.4	70	18078	0.000563	0.000563		1012	0.002185
		0.002371	61.1	5.2		-65					0.6713
20	0.004	0.003	0.61	2.2	2252	-143	0.017928	0.018186	-0.000052	2284	0.018186
35	1.7	0.01	292.9	-0.1	-383	-211	0.003049	-0.000104	-0.000076	131209	0.001548
	-9.98	14.786	674.8	0.1	-14	4278	-0.000108	-0.000108		239	0.001074
		0.002425	50.1	1.6		13					0.3063
21	0	0	0.606	2.2	2242	-4	0.018089	0.018354	-0.000001	2275	0.018354
12	0	0	291.7	-0.1	-385	-178	0.003107	-0.000084	-0.000065	127933	0.001536
	-10.01	14.78	672	0.1	-7	4188	-0.000059	-0.000059		233	0.001055
		0.002413	52.3	1.6		10					0.3131
21	0	0	0.607	3.8	3636	90	0.029194	0.029615	0.000033	3688	0.029615
13	0	0	292.4	0	-620	-55	0.004975	-0.000175	-0.00002	174874	0.002084
	-10.01	14.779	673.6	-0.2	8	5711	0.000066	0.000066		318	0.001099
		0.002413	52.3	2.2		22					0.4728

RUN POINT	V/OR VKTS ALFS,U	MTUN QPSF BARO RHO	MTIP RPM OMEG*R TTEMPF	THETA A1 B1 CONING	LIFTH,C DRAGH,C SIDEH,C	PITCHH,S ROLLH,S TORQ,C HFORCE	CLRH/S CXRH/S CYRH/S	CLRHS/S CXRHS/S CYRHS/S	CMYHS/S CMXHS/S	THRUST POW HP	CTH/S CP/S CPO/S FMERIT
21	0	0	0.604	5.1	4697	32	0.038073	0.038663	0.000012	4770	0.038663
14	0	0	290.9	0.6	-830	167	0.006727	0.000006	0.000062	222312	0.002689
	-10.01	14.779	670.2	0	35	7298	0.000287	0.000287		404	0.001219
		0.002415	51.9	2.7		-1					0.5468
21	0	0	0.607	6.4	6034	-130	0.048504	0.049324	-0.000048	6136	0.049324
15	0	0	292	0.5	-1115	-124	0.008965	0.000397	-0.000045	291335	0.003481
	-10.01	14.779	672.7	0.4	10	9528	0.000081	0.000081		530	0.001363
		0.002417	51.5	3.2		-49					0.6086
21	0	0	0.604	7.6	7133	62	0.05792	0.058867	0.000023	7250	0.058867
16	0	0	290.6	0.5	-1296	110	0.010523	0.000295	0.000041	352780	0.004278
	-10.01	14.778	669.5	0.3	27	11593	0.000215	0.000215		641	0.001516
		0.002416	51.7	3.7		-36					0.6456
21	0	0	0.605	9	8515	68	0.068866	0.07002	0.000025	8658	0.07002
17	0	0	291.1	0.5	-1567	50	0.012671	0.000508	0.000018	442730	0.005339
	-10.01	14.779	670.6	0.5	24	14523	0.00019	0.00019		805	0.001756
		0.002417	51.5	4.4		-63					0.6711
21	0	0	0.605	7.7	7272	-49	0.058885	0.05986	-0.000018	7392	0.05986
18	0	0	291	0.6	-1330	14	0.010768	0.000369	0.000005	359209	0.004339
	-10.01	14.777	670.4	0.3	43	11788	0.000351	0.000351		653	0.001506
		0.002416	51.7	3.8		-46					0.6528
21	0	0	0.605	6.5	6102	185	0.049446	0.050259	0.000068	6202	0.050259
19	0	0	290.9	0.6	-1112	223	0.009008	0.000276	0.000082	293400	0.003548
	-10.01	14.777	670.2	0.3	21	9631	0.000167	0.000167		533	0.001369
		0.002416	51.7	3.2		-34					0.6142

RUN POINT	V/OR VKTS ALFS,U	MTUN QPSF BARO RHO	MTIP RPM OMEG*R TTEMPF	THETA A1 B1 CONING	LIFTH,C DRAGH,C SIDEH,C	PITCHH,S ROLLH,S TORQ,C HFORCE	CLRHS/S CXRHS/S CYRHS/S	CLRH/S CXRH/S CYRH/S	CMYHS/S CMXHS/S	THRUST POW HP	CTH/S CP/S CPO/S FMERIT
21	0	0	0.605	5.3	4868	58	0.03945	0.040105	0.000021	4949	0.040105
20	0	0	290.9	0.5	-891	98	0.00722	0.000252	0.000036	228185	0.002759
	-10.01	14.777	670.2	0.2	12	7491	0.0001	0.0001		415	0.001206
		0.002416	51.7	2.8		-31					0.5629
21	0	0	0.605	3.9	3653	148	0.029586	0.030052	0.000055	3710	0.030052
21	0	0	290.9	0	-651	124	0.005273	0.00005	0.000046	174606	0.00211
	-10.01	14.777	670.2	0	-10	5732	-0.000084	-0.000084		317	0.001103
		0.002417	51.5	2.2		-6					0.4774
21	0	0	0.606	2.7	2604	200	0.021004	0.021333	0.000073	2645	0.021333
22	0	0	291.6	0	-463	295	0.003734	0.000027	0.000108	139445	0.001674
	-10.01	14.777	671.8	0	-10	4567	-0.000079	-0.000079		254	0.001072
		0.002415	51.8	1.7		-3					0.3599
21	0	0	0.605	2.3	2276	-32	0.01844	0.018718	-0.000012	2310	0.018718
32	0	0	290.9	-0.3	-396	-238	0.003212	-0.000042	-0.000088	129220	0.001562
	-10.01	14.774	670.2	0.1	-20	4242	-0.000161	-0.000161		235	0.001067
		0.002416	51.5	1.6		5					0.317
45	0	0	0.605	4.1	3745	-356	0.03033	0.030796	-0.000131	3803	0.030796
15	0	0	292.9	-0.2	-659	-570	0.00534	-0.000008	-0.00021	185890	0.002231
	-10	14.773	674.8	0.2	-1	6061	-0.000011	-0.000011		338	0.001186
		0.002384	58.1	2.3		1					0.4685
45	0	0	0.606	9	8532	-27	0.068818	0.069862	-0.00001	8661	0.069862
16	0	0	293.5	0.4	-1491	-233	0.012029	-0.000104	-0.000086	444561	0.005303
	-10	14.773	676.2	0.2	46	14464	0.000369	0.000369		808	0.001732
		0.002384	58.2	4.2		13					0.6733

RUN POINT	V/OR VKTS ALFS,U	MTUN QPSF BARO RHO	MTIP RPM OMEG*R TTEMPF	THETA A1 B1 CONING	LIFTH,C DRAGH,C SIDEH,C	PITCHH,S ROLLH,S TORQ,C HFORCE	CLRH/S CXRH/S CYRH/S	CLRHS/S CXRHS/S CYRHS/S	CMYHS/S CMXHS/S	THRUST POW HP	CTH/S CP/S CPO/S FMERIT
62	0	0	0.604	4.1	3465	309	0.028139	0.028619	0.000114	3524	0.028619
16	0	0	293.3	0.2	-643	-187	0.005222	0.000257	-0.000069	178302	0.002143
	-10	14.795	675.7	0	-4	5805	-0.000029	-0.000029		324	0.001207
		0.002371	61.1	2.6		-32					0.4369
62	0	0	0.605	5.2	4692	205	0.037949	0.038579	0.000075	4770	0.038579
17	0	0	293.9	0.4	-859	-62	0.006946	0.00025	-0.000023	231422	0.002765
	-10	14.795	677.1	0	11	7519	0.000087	0.000087		421	0.001299
		0.002371	61.1	3.1		-31					0.5301
62	0	0	0.605	6.6	5990	302	0.048478	0.049259	0.000111	6086	0.049259
18	0	0	293.8	0.5	-1080	133	0.00874	0.000189	0.000049	297849	0.003561
	-10	14.796	676.9	0	36	9681	0.000293	0.000293		542	0.001447
		0.002371	61.1	3.6		-23					0.5936
62	0	0	0.606	7.9	7218	312	0.05832	0.059255	0.000115	7333	0.059255
19	0	0	294	0.5	-1298	36	0.010489	0.000203	0.000013	374297	0.004465
	-10	14.797	677.3	0	40	12157	0.000325	0.000325		681	0.001676
		0.002372	61	4.2		-25					0.6247
62	0	0	0.604	8.9	8338	334	0.067637	0.068747	0.000123	8475	0.068747
20	0	0	293.4	0.5	-1517	-186	0.012305	0.000373	-0.000069	444059	0.005329
	-10	14.796	675.9	0.1	16	14453	0.000126	0.000126		807	0.001843
		0.002372	60.9	4.5		-46					0.6541
62	0	0	0.605	10.2	9676	280	0.078388	0.07965	0.000103	9832	0.07965
21	0	0	293.6	0.5	-1744	-209	0.014125	0.000299	-0.000077	540639	0.006475
	-10	14.795	676.4	0.1	15	17584	0.00012	0.00012		983	0.002128
		0.002372	60.9	5		-37					0.6714

RUN POINT	V/OR VKTS ALFS,U	MTUN QPSF BARO RHO	MTIP RPM OMEG*R TTEMPF	THETA A1 B1 CONING	LIFTH,C DRAGH,C SIDEH,C	PITCHH,S ROLLH,S TORQ,C HFORCE	CLRHS/S CXRHS/S CXRHS/S CXRHS/S	CLRH/S CXRH/S CXRHS/S CXRHS/S	CMYHS/S CMXHS/S CMXHS/S CMXHS/S	THRUST POW HP	CTH/S CP/S CPO/S FMERIT
62	0	0	0.605	11.1	10640	364	0.086057	0.087431	0.000134	10810	0.087431
22	0	0	293.9	0.6	-1909	-444	0.015438	0.00026	-0.000163	618254	0.007385
	-10	14.795	677.1	0.1	-15	20088	-0.000118	-0.000118		1124	0.002385
		0.002371	61.1	5.5		-32					0.677
62	0	0	0.606	12.4	11941	-19	0.096467	0.098079	-0.000007	12140	0.098079
23	0	0	294	0.8	-2194	-105	0.017726	0.000705	-0.000038	736213	0.008781
	-10	14.795	677.3	0.5	56	23913	0.00045	0.00045		1339	0.002841
		0.002372	60.9	5.9		-87					0.6764
62	0	0	0.606	13.7	13180	-99	0.10627	0.108074	-0.000036	13404	0.108074
24	0	0	294.3	0.7	-2441	-135	0.019683	0.000931	-0.00005	853251	0.010147
	-10	14.794	678	0.6	68	27686	0.000552	0.000552		1551	0.003276
		0.002372	60.9	6.5		-115					0.6771
62	0	0	0.605	4.2	3850	-122	0.031148	0.031299	-0.000045	3869	0.031299
25	0	0	293.9	-0.8	-382	-852	0.003092	0.000365	-0.000313	185234	0.002213
	-5	14.793	677.1	0.2	-63	6019	-0.000514	-0.000514		337	0.001142
		0.002371	61.1	1.8		-45					0.4838
62	0	0	0.605	5.3	4852	-123	0.039248	0.039443	-0.000045	4876	0.039443
26	0	0	293.9	-0.8	-488	-1036	0.003947	0.000511	-0.000381	232303	0.002775
	-5	14.793	677.1	0.2	-87	7548	-0.000702	-0.000702		422	0.00126
		0.002371	61.1	3		-63					0.5458
62	0	0	0.605	6.5	5991	97	0.048459	0.048675	0.000036	6018	0.048675
27	0	0	293.9	0.3	-568	-119	0.004595	0.000354	-0.000044	287780	0.003438
	-5	14.792	677.1	0.2	-3	9350	-0.000021	-0.000021		523	0.001361
		0.002371	61	3.5		-44					0.6041

RUN POINT	V/OR VKTS ALFS,U	MTUN QPSF BARO RHO	MTIP RPM OMEG*R TTEMPF	THETA A1 B1 CONING	LIFTH,C DRAGH,C SIDEH,C	PITCHH,S ROLLH,S TORQ,C HFORCE	CLRH/S CXRH/S CYRH/S	CLRHS/S CXRHS/S CYRHS/S	CMYHS/S CMXHS/S	THRUST POW HP	CTH/S CP/S CPO/S FMERIT
62	0	0	0.604	7.9	7550	-258	0.061238	0.061521	-0.000095	7585	0.061521
28	0	0	293.5	0	-730	-331	0.005924	0.000564	-0.000122	371208	0.004453
	-5	14.791	676.2	0.2	-15	12078	-0.000123	-0.000123		675	0.001502
		0.002371	61	3.4		-70					0.6627
62	0	0	0.606	8.8	8442	-239	0.068042	0.068366	-0.000087	8482	0.068366
29	0	0	294.4	-0.2	-830	-712	0.006689	0.000734	-0.000261	432986	0.005145
	-5	14.79	678.2	0.2	-59	14045	-0.000475	-0.000475		787	0.001688
		0.002371	60.9	3.3		-91					0.6718
62	0	0	0.604	9.9	9608	-334	0.077941	0.078318	-0.000123	9655	0.078318
30	0	0	293.5	0.2	-953	-267	0.007729	0.000907	-0.000099	516660	0.006198
	-5	14.791	676.2	0.5	-3	16810	-0.000023	-0.000023		939	0.00196
		0.002371	61.1	3.4		-112					0.6838
20	0	0	0.61	2.2	2228	-352	0.017741	0.017751	-0.000128	2230	0.017751
36	0	0	292.9	0.4	-76	106	0.000604	-0.000015	0.000038	128436	0.001515
	-2	14.787	674.8	0.2	-2	4187	-0.000016	-0.000016		234	0.001058
		0.002425	50.1	1.6		2					0.3018
44	0	0	0.605	5.5	5049	53	0.040858	0.040887	0.000019	5053	0.040887
24	0	0	293.9	0.1	-190	163	0.001538	0.000111	0.000006	245034	0.002928
	-2	14.767	677.1	0.1	-9	7962	-0.000077	-0.000077		446	0.001329
		0.00237	60.9	2.7		-14					0.546
44	0	0	0.606	9	8538	251	0.069027	0.069065	0.000092	8542	0.069065
25	0	0	294	0.3	-285	264	0.002303	-0.000108	0.000097	455082	0.005432
	-2	14.768	677.3	0	23	14781	0.000186	0.000186		827	0.001922
		0.00237	60.9	4		13					0.6462

RUN POINT	V/OR VKTS ALFS,U	MTUN QPSF BARO RHO	MTIP RPM OMEG*R TTEMPF	THETA A1 B1 CONING	LIFTH,C DRAGH,C SIDEH,C	PITCHH,S ROLLH,S TORQ,C HFORCE	CLRH/S CXRH/S CYRH/S	CLRHS/S CXRHS/S CYRHS/S	CMYHS/S CMXHS/S	THRUST POW HP	CTH/S CP/S CPO/S FMERIT
62	0	0	0.606	4.2	3803	-629	0.03072	0.030755	-0.000231	3807	0.030755
31	0	0	294.1	-1	-192	-718	0.001547	0.000474	-0.000264	184954	0.002205
	-2	14.793	677.6	0.5	-54	6005	-0.000439	-0.000439		336	0.001162
		0.002371	61.1	1.6		-59					0.473
62	0	0	0.606	5.3	4953	-560	0.039986	0.040032	-0.000205	4959	0.040032
32	0	0	294.2	-1	-252	-940	0.002032	0.000635	-0.000345	235478	0.002805
	-2	14.794	677.8	0.5	-83	7643	-0.000674	-0.000674		428	0.001256
		0.002371	61.1	2.3		-79					0.5523
62	0	0	0.605	6.6	6347	-548	0.051334	0.051389	-0.000202	6354	0.051389
33	0	0	293.9	-1	-308	-832	0.002491	0.000698	-0.000306	300924	0.003594
	-2	14.796	677.1	0.5	-90	9778	-0.000724	-0.000724		547	0.001342
		0.002371	61.1	2.6		-86					0.6267
62	0	0	0.608	7.6	7115	-773	0.057078	0.057144	-0.000282	7123	0.057144
34	0	0	295.1	-0.9	-360	-1059	0.002891	0.000898	-0.000386	353606	0.004172
	-2	14.796	679.9	0.4	-98	11443	-0.000785	-0.000785		643	0.001531
		0.002371	61.1	2.9		-112					0.6331
62	0	0	0.605	8.9	8532	-308	0.068947	0.06901	-0.000113	8539	0.06901
35	0	0	294	0	-372	-354	0.003004	0.000596	-0.00013	441142	0.005263
	-2	14.797	677.3	0.3	-14	14329	-0.000111	-0.000111		802	0.001757
		0.002371	61.1	4.6		-74					0.6661
62	0	0	0.607	10	9736	-219	0.078251	0.078325	-0.00008	9745	0.078325
36	0	0	294.8	0	-433	-628	0.003484	0.000751	-0.000229	528550	0.006255
	-2	14.797	679.2	0.3	-49	17121	-0.000391	-0.000391		961	0.002016
		0.002371	61.1	4.3		-93					0.6777

RUN POINT	V/OR VKTS ALFS,U	MTUN QPSF BARO RHO	MTIP RPM OMEG*R TTEMPF	THETA A1 B1 CONING	LIFTH,C DRAGH,C SIDEH,C	PITCHH,S ROLLH,S TORQ,C HFORCE	CLRH/S CXRH/S CYRH/S	CLRHS/S CXRHS/S CYRHS/S	CMYHS/S CMXHS/S	THRUST POW HP	CTH/S CP/S CPO/S FMERIT
33	0	0	0.604	2.2	2215	229	0.018168	0.018181	0.000085	2216	0.018181
17	0	0	291.6	0.1	-83	112	0.000679	0.000045	0.000042	124764	0.001524
	-2	14.653	671.8	-0.3	-11	4086	-0.000094	-0.000094		227	0.001049
		0.002375	55.7	1.6		-5					0.3112
33	0	0	0.607	4	3712	46	0.030167	0.030188	0.000017	3715	0.030188
18	0	0	293.1	0	-138	-2	0.001124	0.000071	-0.000001	176440	0.002124
	-2	14.652	675.3	-0.2	-4	5748	-0.000032	-0.000032		321	0.001109
		0.002373	56.1	2.3		-9					0.4777
33	0	0	0.607	5.2	4868	8	0.039456	0.039488	0.000003	4871	0.039488
19	0	0	293.5	0.3	-196	-95	0.001592	0.000214	-0.000035	228636	0.002741
	-2	14.652	676.2	0	5	7439	0.000043	0.000043		416	0.001223
		0.002372	56.2	2.7		-26					0.5536
33	0	0	0.607	6.6	6213	194	0.050465	0.050501	0.000072	6218	0.050501
20	0	0	293.1	0.7	-234	173	0.001901	0.000138	0.000064	295025	0.003549
	-2	14.651	675.3	0.1	38	9612	0.000305	0.000305		536	0.001354
		0.002374	55.8	3.4		-17					0.6185
33	0	0	0.603	7.7	7334	-34	0.060249	0.060292	-0.000013	7339	0.060292
21	0	0	291.4	0.6	-281	111	0.002308	0.000204	0.000041	355167	0.004346
	-2	14.651	671.3	0	46	11639	0.000382	0.000382		646	0.001483
		0.002375	55.7	3.8		-25					0.6587
33	0	0	0.605	9.1	8694	-29	0.071108	0.071167	-0.000011	8702	0.071167
22	0	0	292	0.7	-361	233	0.002951	0.000468	0.000086	444161	0.0054
	-2	14.65	672.7	0.4	51	14525	0.000414	0.000414		808	0.001728
		0.002375	55.5	4.3		-57					0.6799

RUN POINT	V/OR VKTS ALFS,U	MTUN QPSF BARO RHO	MTIP RPM OMEG*R TTEMPF	THETA A1 B1 CONING	LIFTH,C DRAGH,C SIDEH,C	PITCHH,S ROLLH,S TORQ,C HFORCE	CLRH/S CXRH/S CYRH/S	CLRHS/S CXRHS/S CYRHS/S	CMYHS/S CMXHS/S	THRUST POW HP	CTH/S CP/S CPO/S FMERIT
33	0	0	0.607	9.9	9620	-274	0.078106	0.078166	-0.000101	9627	0.078166
23	0	0	293	0.7	-377	128	0.003064	0.000337	0.000047	507450	0.006104
	-2	14.65	675	0.2	85	16539	0.000692	0.000692		923	0.001877
		0.002376	55.3	4.6		-41					0.6924
36	0	0	0.605	11.1	10829	-143	0.088278	0.088278	-0.000053	10829	0.088278
34	0	0	293.7	0.7	-16	292	0.000128	0.000143	0.000108	615810	0.007419
	0.01	14.7	676.6	0.3	102	20022	0.000828	0.000828		1120	0.002347
		0.002356	61.4	5.1		-18					0.6837
37	0	0	0.605	10.7	10538	118	0.085743	0.085743	0.000044	10538	0.085743
32	0	0	292.9	0	30	-64	-0.000247	-0.000247	-0.000024	558813	0.006738
	0	14.709	674.8	-0.3	-18	18219	-0.000147	-0.000147		1016	0.001882
		0.002373	57.8	5		30					0.7206
39	0	0	0.606	8.1	7569	80	0.061104	0.061104	0.000029	7569	0.061104
34	0	0	292.6	0.3	9	-122	-0.000076	-0.000076	-0.000045	377670	0.004523
	0	14.76	674.1	-0.1	20	12326	0.00016	0.00016		687	0.001602
		0.002397	54.8	3.9		9					0.6458
42	0	0	0.603	4.1	3748	-135	0.030505	0.030505	-0.00005	3748	0.030505
5	0	0	290.9	-0.1	16	-156	-0.000129	-0.000129	-0.000058	181634	0.002206
	0	14.771	670.2	0	-6	5962	-0.000051	-0.000051		330	0.001176
		0.002405	53.8	2.2		16					0.467
42	0	0	0.606	6.7	6331	-424	0.051005	0.051005	-0.000155	6331	0.051005
6	0	0	292.4	0.5	-20	65	0.000163	0.000163	0.000024	301930	0.003611
	0	14.77	673.6	0.1	57	9861	0.000457	0.000457		549	0.001383
		0.002405	53.8	3.3		-20					0.6169

RUN POINT	V/OR VKTS ALFS,U	MTUN QPSF BARO RHO	MTIP RPM OMEG*R TTEMPF	THETA A1 B1 CONING	LIFTH,C DRAGH,C SIDEH,C	PITCHH,S ROLLH,S TORQ,C HFORCE	CLRH/S CXRH/S CYRH/S	CLRHS/S CXRHS/S CYRHS/S	CMYHS/S CMXHS/S	THRUST POW HP	CTH/S CP/S CPO/S FMERIT
42	0	0	0.606	4.2	3841	-250	0.031008	0.031008	-0.000092	3841	0.031008
7	0	0	292.1	0.3	5	82	-0.000042	-0.000042	0.000003	183248	0.002199
	0	14.77	673	0	27	5991	0.000218	0.000218		333	0.001143
		0.002405	53.8	2.3		5					0.4803
42	0	0	0.605	6.7	6323	-27	0.051243	0.051243	-0.000001	6323	0.051243
8	0	0	291.6	0.2	3	154	-0.000021	-0.000021	0.000057	291211	0.003513
	0	14.769	671.8	0.1	26	9537	0.000211	0.000211		529	0.001269
		0.002404	53.9	3.3		3					0.6386
43	0	0	0.606	4	3768	41	0.030319	0.030437	0.000015	3783	0.030437
27	0	0	292.9	-0.4	333	-3	-0.002676	-0.000023	-0.000001	182003	0.00217
	5	14.8	674.8	-0.1	-15	5934	-0.000123	-0.000123		331	0.001143
		0.0024	56.1	2.2		3					0.4732
43	0	0	0.606	5.2	4917	-53	0.039617	0.039771	-0.000002	4936	0.039771
28	0	0	292.7	-0.4	434	-19	-0.003498	-0.000032	-0.000007	231136	0.002762
	5	14.8	674.3	0	-19	7541	-0.000152	-0.000152		420	0.001228
		0.0024	56.1	2.7		4					0.5554
43	0	0	0.606	6.4	6068	145	0.048916	0.049137	0.000053	6096	0.049137
29	0	0	292.6	-0.2	580	48	-0.004676	-0.000395	0.000018	287852	0.003442
	5	14.8	674.1	-0.5	9	9394	0.000071	0.000071		523	0.001336
		0.0024	56	3.2		49					0.612
43	0	0	0.606	7.7	7508	20	0.060428	0.06067	0.000007	7538	0.06067
30	0	0	292.8	-0.4	672	-70	-0.00541	-0.000123	-0.000026	361646	0.004315
	5	14.8	674.6	-0.1	-31	11795	-0.000249	-0.000249		658	0.001425
		0.002401	55.9	3.8		15					0.6698

RUN POINT	V/OR VKTS ALFS,U	MTUN QPSF BARO RHO	MTIP RPM OMEG*R TTEMPF	THETA A1 B1 CONING	LIFTH,C DRAGH,C SIDEH,C	PITCHH,S ROLLH,S TORQ,C HFORCE	CLRH/S CXRH/S CYRH/S	CLRHS/S CXRHS/S CYRHS/S	CMYHS/S CMXHS/S	THRUST POW HP	CTH/S CP/S CPO/S FMERIT
43	0	0	0.605	9	8761	-217	0.070669	0.070933	-0.000079	8794	0.070933
31	0	0	292.4	-0.4	759	-143	-0.006126	0.000057	-0.000052	437060	0.005233
	5	14.8	673.6	0.1	-28	14274	-0.000225	-0.000225		795	0.00158
		0.002402	55.7	4.4		-7					0.6981
46	0	0	0.606	4.1	3778	-47	0.030403	0.030505	-0.000017	3791	0.030505
16	0	0	292.6	-0.2	310	-4	-0.002498	0.000161	-0.000001	185817	0.002218
	5	14.787	674.1	0.2	-30	6064	-0.000238	-0.000238		338	0.001188
		0.002404	54.7	2.2		-20					0.4645
46	0	0	0.604	8.9	8647	174	0.070092	0.070371	0.000064	8681	0.070371
17	0	0	291.4	-0.1	772	-18	-0.006258	-0.000126	-0.000007	438491	0.005295
	5	14.788	671.3	0	-31	14370	-0.000254	-0.000254		797	0.001685
		0.002406	54.3	4.2		15					0.6818
46	0	0	0.605	12.6	12508	-22	0.101167	0.101581	-0.000008	12559	0.101581
18	0	0	291.7	0.2	1132	355	-0.009158	-0.000306	0.00013	738735	0.008891
	5	14.787	672	0.2	48	24184	0.000386	0.000386		1343	0.00263
		0.002407	54.2	5.8		38					0.7042
41	0	0	0.603	12.5	12096	-447	0.098491	0.100003	-0.000165	12281	0.100003
30	0	0	291.2	-0.3	2128	-143	-0.017324	0.000042	-0.000053	722457	0.008769
	10	14.766	670.9	0.9	-69	23691	-0.000559	-0.000559		1314	0.002653
		0.002399	54.7	5.7		-5					0.6974
41	0	0	0.603	8.9	8318	-89	0.06771	0.068766	-0.000033	8448	0.068766
31	0	0	291.2	0.1	1475	-115	-0.012006	-0.000066	-0.000042	432990	0.005254
	10	14.766	670.9	0.2	-18	14199	-0.000144	-0.000144		787	0.001766
		0.0024	54.6	4.2		8					0.6638

RUN POINT	V/OR VKTS ALFS,U	MTUN QPSF BARO RHO	MTIP RPM OMEG*R TTEMPF	THETA A1 B1 CONING	LIFTH,C DRAGH,C SIDEH,C	PITCHH,S ROLLH,S TORQ,C HFORCE	CLRH/S CXRH/S CYRH/S	CLRHS/S CXRHS/S CYRHS/S	CMYHS/S CMXHS/S	THRUST POW HP	CTH/S CP/S CPO/S FMERIT
41	0	0	0.604	2.3	2291	-328	0.018642	0.01893	-0.000121	2326	0.01893
32	0	0	291.3	0.2	404	359	-0.003288	-0.000001	0.000133	129527	0.00157
	10	14.766	671.1	0.3	0	4246	-0.000003	-0.000003		236	0.001067
		0.002399	54.7	1.7		0					0.3207
43	0	0	0.606	3.9	3619	11	0.029165	0.029621	0.000004	3676	0.029621
24	0	0	292.8	-0.4	643	94	-0.005182	-0.000039	0.000034	177924	0.002125
	10	14.801	674.6	-0.1	-5	5803	-0.000044	-0.000044		323	0.001139
		0.002398	56.5	2.2		5					0.4639
43	0	0	0.605	5.3	4929	-113	0.03987	0.040486	-0.000042	5005	0.040486
25	0	0	292.2	-0.3	870	122	-0.007038	-0.000008	0.000045	233698	0.002808
	10	14.799	673.2	-0.1	-8	7637	-0.000067	-0.000067		425	0.001233
		0.002398	56.3	2.8		1					0.561
43	0	0	0.604	6.6	6224	-99	0.050384	0.051159	-0.000037	6320	0.051159
26	0	0	292	-0.3	1095	130	-0.008868	0.000016	0.000048	298267	0.003589
	10	14.801	672.7	0	-13	9754	-0.000101	-0.000101		542	0.001351
		0.0024	56.1	3.3		-2					0.6234
43	0	0	0.605	4.1	3676	211	0.029672	0.030723	0.000078	3806	0.030723
16	0	0	292.3	-0.3	987	129	-0.00797	-0.000019	0.000047	182291	0.002185
	15	14.799	673.4	-0.3	-11	5955	-0.00009	-0.00009		331	0.001143
		0.002402	55.5	2.3		2					0.4766
43	0	0	0.605	5.3	4765	149	0.038437	0.039795	0.000055	4934	0.039795
17	0	0	292.4	-0.5	1278	65	-0.010311	-0.000011	0.000024	232470	0.002783
	15	14.799	673.6	-0.2	-35	7592	-0.000281	-0.000281		423	0.001248
		0.002402	55.5	2.8		1					0.5516

RUN POINT	V/OR VKTS ALFS,U	MTUN QPSF BARO RHO	MTIP RPM OMEG*R TTEMPF	THETA A1 B1 CONING	LIFTH,C DRAGH,C SIDEH,C	PITCHH,S ROLLH,S TORQ,C HFORCE	CLRH/S CXRH/S CYRH/S	CLRHS/S CXRHS/S CYRHS/S	CMYHS/S CMXHS/S	THRUST POW HP	CTH/S CP/S CPO/S FMERIT
43	0	0	0.605	6.7	6228	7	0.050284	0.052063	0.000003	6448	0.052063
18	0	0	292.3	-0.5	1671	23	-0.013493	-0.000019	0.000008	303129	0.003634
	15	14.799	673.4	-0.2	-32	9903	-0.000257	-0.000257		551	0.001337
		0.002401	55.7	3.4		2					0.6321
43	0	0	0.606	7.7	7153	-54	0.0576	0.059655	-0.00002	7408	0.059655
19	0	0	292.8	-0.5	1928	44	-0.015523	-0.000087	0.000016	361646	0.004317
	15	14.799	674.6	-0.2	-30	11795	-0.000238	-0.000238		658	0.001499
		0.002399	56.1	3.8		11					0.6526
43	0	0	0.606	9	8531	-168	0.068583	0.071014	-0.000061	8834	0.071014
20	0	0	293.1	-0.5	2291	27	-0.01842	-0.000041	0.00001	447424	0.005327
	15	14.799	675.3	-0.2	-31	14577	-0.000252	-0.000252		813	0.001667
		0.002399	56.3	4.2		5					0.687
43	0	0	0.605	10.2	9703	14	0.07819	0.081131	0.000005	10068	0.081131
21	0	0	292.7	-0.6	2687	263	-0.021656	-0.000068	0.000096	538500	0.006435
	15	14.81	674.3	-0.4	-12	17568	-0.000098	-0.000098		979	0.001966
		0.002399	56.5	4.8		84					0.6945
43	0	0	0.606	11.1	10760	-224	0.086682	0.089817	-0.000082	11149	0.089817
22	0	0	292.8	-0.9	2920	52	-0.023526	-0.000289	0.000019	612208	0.007311
	15	14.803	674.6	-0.2	-54	19966	-0.000438	-0.000438		1113	0.002106
		0.002398	56.5	5.2		36					0.712
43	0	0	0.606	12.3	11880	-22	0.095569	0.099158	-0.000008	12326	0.099158
23	0	0	293	-0.7	3288	50	-0.02645	-0.000814	0.000018	715368	0.008526
	15	14.809	675	-0.4	-44	23315	-0.00035	-0.00035		1301	0.002487
		0.002398	56.7	5.7		101					0.7083

RUN POINT	V/OR VKTS ALFS,U	MTUN QPSF BARO RHO	MTIP RPM OMEG*R TTEMPF	THETA A1 B1 CONING	LIFTH,C DRAGH,C SIDEH,C	PITCHH,S ROLLH,S TORQ,C HFORCE	CLRH/S CXRH/S CYRH/S	CLRHS/S CXRHS/S CYRHS/S	CMYHS/S CMXHS/S	THRUST POW HP	CTH/S CP/S CPO/S FMERIT
54	0	0	0.608	4	3434	-391	0.027506	0.028546	-0.000142	3564	0.028546
5	0	0	294.8	-0.2	954	-400	-0.007638	-0.000259	-0.000146	181349	0.002139
	15	14.773	679.2	0	17	5874	0.00014	0.00014		330	0.001206
		0.00238	59.1	2		32					0.4361
54	0	0	0.606	5.4	4748	-347	0.038281	0.039734	-0.000127	4928	0.039734
6	0	0	293.8	0.1	1321	-185	-0.010654	-0.000383	-0.000068	235661	0.002807
	15	14.773	676.9	0	34	7660	0.000277	0.000277		428	0.001275
		0.00238	59	2.7		47					0.5456
54	0	0	0.605	6.6	5719	-304	0.046291	0.048005	-0.000112	5931	0.048005
7	0	0	293.2	0.3	1571	-336	-0.012715	-0.000301	-0.000124	296540	0.003553
	15	14.773	675.5	0.1	48	9658	0.000388	0.000388		539	0.001519
		0.002381	58.9	3.1		37					0.5724
54	0	0	0.607	7.8	7133	-494	0.057452	0.059552	-0.000181	7394	0.059552
8	0	0	293.9	0	1946	-299	-0.015675	-0.000271	-0.00011	369966	0.004401
	15	14.774	677.1	0.2	38	12021	0.000309	0.000309		673	0.00159
		0.002381	58.9	3.7		34					0.6386
54	0	0	0.606	8.9	8145	-413	0.065716	0.068096	-0.000151	8440	0.068096
9	0	0	293.6	0.2	2212	-502	-0.017846	-0.000229	-0.000184	444842	0.005306
	15	14.775	676.4	0.1	28	14468	0.000228	0.000228		809	0.00187
		0.002382	58.8	4.1		28					0.6476
54	0	0	0.606	10.2	9651	-194	0.07775	0.080677	-0.000071	10014	0.080677
10	0	0	293.8	0.2	2675	-274	-0.021547	-0.00069	-0.0001	540573	0.006434
	15	14.775	676.9	-0.1	76	17570	0.000611	0.000611		983	0.002002
		0.002382	58.7	4.7		86					0.6888

RUN POINT	V/OR VKTS ALFS,U	MTUN QPSF BARO RHO	MTIP RPM OMEG*R TTEMPF	THETA A1 B1 CONING	LIFTH,C DRAGH,C SIDEH,C	PITCHH,S ROLLH,S TORQ,C HFORCE	CLRH/S CXRH/S CYRH/S	CLRHS/S CXRHS/S CYRHS/S	CMYHS/S CMXHS/S	THRUST POW HP	CTH/S CP/S CPO/S FMERIT
54	0	0	0.603	11.5	10667	-594	0.086843	0.089912	-0.00022	11043	0.089912
11	0	0	292.3	0.5	2860	-404	-0.023289	-0.000018	-0.000149	638567	0.00772
	15	14.776	673.4	0.3	92	20862	0.000751	0.000751		1161	0.002506
		0.002381	58.9	5.1		2					0.6753
52	0	0	0.604	3.8	3591	-136	0.029118	0.030181	-0.00005	3722	0.030181
6	0	0	291.9	0.1	980	-185	-0.007943	-0.000136	-0.000068	173798	0.002095
	15	14.779	672.5	0	3	5686	0.000027	0.000027		316	0.001081
		0.002398	55.3	2.2		17					0.4839
52	0	0	0.606	5	4811	-258	0.0388	0.040189	-0.000094	4984	0.040189
7	0	0	292.7	0	1299	-25	-0.010476	-0.000077	-0.000009	222625	0.002662
	15	14.779	674.3	0.2	14	7263	0.000113	0.000113		405	0.001104
		0.002398	55.3	2.7		10					0.5852
52	0	0	0.606	6.1	5891	-384	0.047507	0.049174	-0.000141	6098	0.049174
8	0	0	292.7	0.1	1574	-8	-0.012695	0.000033	-0.000003	268426	0.00321
	15	14.779	674.3	0.3	19	8757	0.000152	0.000152		488	0.001101
		0.002398	55.3	3.1		-4					0.6569
52	0	0	0.606	7.3	7307	-235	0.059033	0.061121	-0.000086	7565	0.061121
9	0	0	292.4	0.1	1961	-66	-0.01584	-0.000021	-0.000024	340434	0.004083
	15	14.779	673.6	0.3	9	11118	0.000072	0.000072		619	0.001161
		0.002398	55.2	3.8		3					0.7157
52	0	0	0.606	8.4	8411	-257	0.067841	0.070223	-0.000094	8706	0.070223
10	0	0	292.6	0	2248	-143	-0.018131	0.000045	-0.000052	407773	0.004879
	15	14.779	674.1	0.3	-5	13308	-0.000042	-0.000042		741	0.001281
		0.002399	55.1	4.4		-6					0.7375

RUN POINT	V/OR VKTS ALFS,U	MTUN QPSF BARO RHO	MTIP RPM OMEG*R TTEMPF	THETA A1 B1 CONING	LIFTH,C DRAGH,C SIDEH,C	PITCHH,S ROLLH,S TORQ,C HFORCE	CLRH/S CXRH/S CYRH/S	CLRHS/S CXRHS/S CYRHS/S	CMYHS/S CMXHS/S	THRUST POW HP	CTH/S CP/S CPO/S FMERIT
52	0	0	0.605	9.4	9427	-247	0.076298	0.078979	-0.000091	9758	0.078979
11	0	0	292.1	0	2521	-145	-0.020402	0.000041	-0.000053	476698	0.005734
	15	14.779	673	0.4	-16	15584	-0.000132	-0.000132		867	0.001441
		0.002399	55.1	4.6		-5					0.7486
52	0	0	0.606	10.4	10807	-361	0.087234	0.090254	-0.000132	11182	0.090254
12	0	0	292.5	-0.4	2868	-299	-0.023151	0.000215	-0.00011	560529	0.006714
	15	14.779	673.9	0.4	-48	18300	-0.000385	-0.000385		1019	0.00147
		0.002399	55.1	5.2		-27					0.781
52	0	0	0.606	11.3	12082	17	0.097527	0.101	0.000006	12512	0.101
13	0	0	292.5	-0.2	3253	137	-0.026259	-0.000123	0.00005	640279	0.00767
	15	14.779	673.9	0.6	-15	20903	-0.000121	-0.000121		1164	0.001462
		0.002399	55.1	5.6		15					0.8093
52	0	0	0.607	12.7	13316	8	0.107126	0.111029	0.000003	13801	0.111029
14	0	0	293	-0.1	3628	-75	-0.029183	-0.000462	-0.000027	770724	0.009185
	15	14.778	675	0.4	-53	25119	-0.000426	-0.000426		1401	0.002031
		0.002398	55.1	6.2		57					0.7789
52	0	0	0.604	13.9	13955	-115	0.113395	0.117498	-0.000043	14460	0.117498
15	0	0	291.5	-0.2	3788	-283	-0.03078	-0.000382	-0.000105	869803	0.010525
	15	14.778	671.6	0.4	-79	28494	-0.000639	-0.000639		1581	0.002735
		0.002399	55	6.8		47					0.74
52	0	0	0.604	4.4	4217	-67	0.034245	0.035475	-0.000025	4369	0.035475
16	0	0	291.6	-0.2	1140	-119	-0.009258	-0.000079	-0.000044	196472	0.002375
	15	14.777	671.8	0.1	-10	6434	-0.000082	-0.000082		357	0.001083
		0.002399	54.9	2.5		10					0.5441

RUN POINT	V/OR VKTS ALFS,U	MTUN QPSF BARO RHO	MTIP RPM OMEG*R TTEMPF	THETA A1 B1 CONING	LIFTH,C DRAGH,C SIDEH,C	PITCHH,S ROLLH,S TORQ,C HFORCE	CLRH/S CXRH/S CYRH/S	CLRHS/S CXRHS/S CYRHS/S	CMYHS/S CMXHS/S	THRUST POW HP	CTH/S CP/S CPO/S FMERIT
52	0	0	0.604	5.5	5335	-449	0.043346	0.044833	-0.000166	5517	0.044833
17	0	0	291.5	-0.1	1409	-183	-0.011449	0.00016	-0.000068	241801	0.002926
	15	14.777	671.6	0.4	-12	7921	-0.000096	-0.000096		440	0.00109
		0.002399	54.9	2.9		-20					0.6275
52	0	0	0.605	6.6	6614	-81	0.053525	0.055419	-0.00003	6848	0.055419
18	0	0	292.1	0	1775	-129	-0.014366	-0.000024	-0.000048	303273	0.003647
	15	14.777	673	0.2	-23	9915	-0.000185	-0.000185		551	0.001124
		0.002399	54.9	3.4		3					0.6918
52	0	0	0.607	7.6	7542	-179	0.0607	0.062845	-0.000065	7809	0.062845
19	0	0	292.9	0	2023	-162	-0.016278	-0.000013	-0.000059	355375	0.004238
	15	14.777	674.8	0.2	-10	11586	-0.000083	-0.000083		646	0.001192
		0.002399	54.9	4		2					0.7188
52	0	0	0.606	8.7	8816	-419	0.071101	0.07353	-0.000154	9118	0.07353
20	0	0	292.6	-0.1	2325	-206	-0.018747	0.000294	-0.000076	424276	0.005076
	15	14.777	674.1	0.6	-33	13847	-0.000268	-0.000268		771	0.00122
		0.002399	54.9	4.3		-36					0.7596
52	0	0	0.605	9.6	9955	-313	0.080558	0.0833	-0.000115	10294	0.0833
21	0	0	292.1	-0.4	2620	-223	-0.0212	0.000373	-0.000082	488653	0.005876
	15	14.777	673	0.6	-83	15975	-0.000673	-0.000673		888	0.001227
		0.002399	54.9	4.9		-46					0.7912
52	0	0	0.605	11	11455	-366	0.092861	0.096104	-0.000135	11855	0.096104
22	0	0	291.9	0.1	3054	138	-0.024755	0.000122	0.000051	604149	0.007283
	15	14.777	672.5	0.5	27	19764	0.000217	0.000217		1098	0.001521
		0.002398	55.1	5.6		-15					0.7911

RUN POINT	V/OR VKTS ALFS,U	MTUN QPSF BARO RHO	MTIP RPM OMEG*R TTEMPF	THETA A1 B1 CONING	LIFTH,C DRAGH,C SIDEH,C	PITCHH,S ROLLH,S TORQ,C HFORCE	CLRHS/S CXRHS/S CYRHS/S	CLRH/S CXRH/S CYRH/S	CMYHS/S CMXHS/S	THRUST POW HP	CTH/S CP/S CPO/S FMERIT
52	0	0	0.607	11.8	12396	-186	0.099663	0.103137	-0.000068	12828	0.103137
23	0	0	293.1	-0.5	3302	-133	-0.026545	0.000154	-0.000049	673590	0.00802
	15	14.777	675.3	0.6	-85	21946	-0.000687	-0.000687		1225	0.001615
		0.002398	55.1	5.9		-19					0.7986
52	0	0	0.608	13.2	13911	-297	0.111616	0.115527	-0.000108	14398	0.115527
24	0	0	293.4	-0.4	3714	-284	-0.029803	0.000101	-0.000103	822663	0.009765
	15	14.777	675.9	0.5	-84	26775	-0.000673	-0.000673		1496	0.002171
		0.002398	55.1	6.5		-13					0.7776

APPENDIX B

**FORWARD FLIGHT
PERFORMANCE DATA**

Forward Flight Performance Data

Performance data are divided into two sections; thrust sweep data and speed sweep data. Data for both forward flight thrust sweep conditions and speed sweep conditions with minimized flapping trim are presented in tabulated form in this appendix. Thrust sweep data runs are grouped in terms of increasing rotor advance ratio and shaft angle-of-attack, α_S . Speed sweep data runs are grouped in terms of increasing shaft angle-of-attack, α_S and thrust condition. No wall corrections have been applied to this data. Definitions of the measurements that are presented in this section are shown below. Identification of test conditions and its location within this appendix are presented following these definitions.

Nomenclature

A	rotor disk area, πR^2 , ft ²
ALFS,U, α_S	rotor shaft angle, positive aft of vertical, deg
A1	coefficient in the representation of rotor blade lateral cyclic pitch (fixed system measurement) $\theta = \text{THETA} - A1 \cos \psi - B1 \sin \psi$, deg
b	number of rotor blades
B1	coefficient in the representation of rotor blade longitudinal cyclic pitch (fixed system measurement) $\theta = \text{THETA} - A1 \cos \psi - B1 \sin \psi$, deg
BARO	atmospheric pressure, lb/ft ²
c	airfoil chord length, ft
CLRHS/S	rotor lift force coefficient divided by rotor solidity, wind axis, positive up, $\text{LIFTH,C}/\rho(\Omega R)^2 S_R$
CLRHS/S	rotor lift force coefficient divided by rotor solidity, shaft axis, $\text{LIFTH,S}/\rho(\Omega R)^2 S_R$
CMXHS/S	rotor rolling moment coefficient divided by rotor solidity, shaft axis, $\text{ROLLH,S}/\rho S_R(\Omega R)^2 R$
CMYHS/S	rotor pitching moment coefficient divided by rotor solidity, shaft axis, $\text{PITCHH,S}/\rho S_R(\Omega R)^2 R$
CONING	mean flap angle, deg
CP/S	rotor power coefficient divided by rotor solidity, $\text{POW}/\rho(\Omega R)^3 S_R$
CPO/S	rotor non-ideal power coefficient divided by rotor solidity, CP/S - CP/S ideal
C _S	speed of sound, ft/s
CTH/S	rotor thrust coefficient divided by rotor solidity, $\text{THRUST}/\rho(\Omega R)^2 S_R$
CXRHS/S	rotor propulsive force coefficient divided by rotor solidity, wind axis, positive forward, $-\text{DRAGH,C}/\rho(\Omega R)^2 S_R$
CXRHS/S	rotor propulsive force coefficient divided by rotor solidity, shaft axis, positive forward, $-\text{DRAGH,S}/\rho(\Omega R)^2 S_R$
CYRHS/S	rotor side force coefficient divided by rotor solidity, wind axis, $\text{SIDEH,C}/\rho(\Omega R)^2 S_R$

CYRHS/S	rotor side force coefficient divided by rotor solidity, shaft axis, $SIDEH,S/\rho(\Omega R)^2 S_R$
DRAGH,C	rotor wind-axis drag, positive downstream, lb
DRAGH,S	rotor shaft-axis drag, positive downstream, lb
FE	equivalent rotor drag area, ft^2
f_{hel}	equivalent airframe drag area, ft^2
HFORCE	rotor propulsive force, shaft axis, positive forward, lb
HP	rotor horsepower, $POW/550$
L/DR	rotor lift to drag ratio
LIFTH,C	rotor wind-axis lift, positive up, lb
LIFTH,S	rotor shaft-axis lift, positive up, lb
MTUN	tunnel Mach number, V/CS
MTIP	rotor rotational tip Mach number, $\Omega R/CS$
OMEG*R	rotor tip speed, ΩR , ft/sec
PITCHH,S	rotor shaft-axis pitching moment, positive nose up, ft-lb
POINT	data point number
POW	rotor shaft power, $TORQ,C * \Omega$, ft-lb/s
QPSF	free-stream dynamic pressure, lb/ft^2
R	rotor radius, ft
RHO, ρ	free-stream air density, ρ , slug/ ft^3
ROLLH,S	rotor shaft-axis rolling moment, positive right wing down, ft-lb
RPM	rotor rotation rate, rev/min.
RUN	data run number
SIDEH,C	rotor side force, wind axis, positive right, lb
SIDEH,S	rotor side force, shaft-axis, positive right, lb
SKANGLE	rotor wake skew angle, positive relative to normal to rotor disk, $\tan^{-1}(\mu^*/\lambda)$, deg
S_R	rotor blade area, bcR , ft^2
THETA	rotor collective(fixed system measurments), deg

THRUST	rotor thrust, perpendicular to tip-path-plane, positive up, lb
TORQ,C	flexcoupling or rotor shaft torque, ft-lb
TTEMPF	tunnel air temp, F°
V/OR, μ	rotor advance ratio, $V/\Omega R$
V	free stream velocity, ft/s
VD	rotor vehicle descent, positive down, $60 * V * \sin(\tan^{-1}((\text{DRAGH,C} - f_{\text{hel}} * \text{QPSF}) / \text{LIFTH,C}))$, ft/min
VKTS	free stream velocity, kt
θ	blade pitch at specific blade azimuth position (ψ), deg
λ	inflow ratio where velocity normal to disk, $(V(-\text{ALFS,u}) + v) / \Omega R$ or $\mu * \tan(-\text{ALFS,U}) + \lambda_i$
λ_i	induced inflow ratio
μ^*	advance ratio prime where velocity parallel to rotor disk, $V \cos(-\text{ALFS,U}) / \Omega R$
v	induced velocity, ft/s
σ	rotor solidity, $bc/\pi R$
ψ	rotor blade azimuth angle measured from downwind position in direction of rotation, deg
Ω	rotor rotational speed, rad/s

Thrust Sweep Performance Data Index

V/OR Advance Ratio	ALFS,U deg	RUN	PTS	CTH/S	DATA LOCATION
0.050	-2	44	14-23	.030-->.120	B-9 to B-10
0.081	0	48	32-36	.038-->.075	B-8 to B-11
-----	-----	-----	-----	-----	-----
0.100	-15	63	9-18	.030-->.120	B-11 to B-13
0.100	-10	45	5-14	.030-->.120	B-13 to B-14
0.100	-2	44	6-13	.038-->.100	B-14 to B-16
0.100	5	46	5-10	.050-->.100	B-16 to B-17
0.100	10	47 49	5-8 5-12	.070-->.101 .070-->.120	B-17 B-17 to B-19
-----	-----	-----	-----	-----	-----
0.125	5	26 29	12-18 5-12	.054-->.111 .060-->.100	B-19 to B-20 B-20 to B-21
0.125	10	30	5-11	.064-->.121	B-21 to B-22
-----	-----	-----	-----	-----	-----
0.150	-15	63	19-27	.031-->.111	B-22 to B-24
0.150	-10	21 22	23-31 12-22	.031-->.098 .023-->.119	B-24 to B-25 B-25 to B-27
0.150	-2	24	7-13	.041-->.120	B-27 to B-28
0.150	5	28	7-14	.059-->.119	B-28 to B-30
0.150	10	30	12-17	.070-->.119	B-30 to B-31

**Thrust Sweep Performance Data Index
(Continued)**

V/OR Advance Ratio	ALFS,U deg	RUN	PTS	CTH/S	DATA LOCATION
.200	-10	22	23-27	.014-->.060	B-31
		23	5-14	.015-->.120	B-32 to B-33
.200	-2	25	5-13	.041-->.118	B-33 to B-35
.200	5	28	15-21	.063-->.120	B-35 to B-36
.200	10	30	18-23	.078-->.121	B-36 to B-37
-----	-----	-----	-----	-----	-----
.250	-15	63	28-35	.031-->.090	B-37 to B-38
.250	-10	23	15-24	.030-->.116	B-38 to B-40
.250	-2	25	14-21	.038-->.105	B-40 to B-41
.250	5	29	13-19	.070-->.120	B-41 to B-42
.250	10	31	11-16	.083-->.120	B-42 to B-43

Speed Sweep Performance Data Index

ALFS,U deg	CTH/S	RUN	PTS	V/OR Advance Ratio	DATA LOCATION
-10	0.065	36	6-11, 22-33	.251-->.006	B-44 to B-46
-5	0.065	51	5-18	.250-->.011	B-47 to B-49
-2	0.065	32	7-19	.250-->.000	B-49 to B-51
	0.065	34	5-18	.250-->.032	B-51 to B-53
5	0.065	38	5-21	.250-->.010	B-53 to B-56
-----	-----	-----	-----	-----	-----
-10	0.080	37	5-18	.251-->.011	B-56 to B-58
-5	0.080	53	5-10,12-21	.250-->.014	B-59 to B-61
-2	0.080	32	20-32	.250-->.000	B-61 to B-63
	0.080	35	5-19	.251-->.031	B-63 to B-66
0	0.080	48	5-31	.013->.250->0	B-66 to B-70
5	0.080	39	6-20	.250-->.011	B-70 to B-73
10	.0080	41	5-18	.252-->.010	B-73 to B-75
-----	-----	-----	-----	-----	-----
10	0.084	31	17-22	.252-->.080	B-75 to B-76
-----	-----	-----	-----	-----	-----
-10	0.100	37	19-31	.251-->.011	B-76 to B-78
-2	0.100	33	5-15	.251-->.000	B-78 to B-80
		35	20-30	.251-->.030	B-80 to B-82
5	0.100	39	21-32	.249-->.010	B-82 to B-84
10	0.100	41	19-30	.251-->.000	B-84 to B-86

RUN POINT	V/OR VKTS ALFS,U	MTUN QPSF BARO RHO	MTIP RPM OMEG*R TTEMPF	THETA A1 B1 CONING	LIFTH,C DRAGH,C SIDEH,C SKANGLE	PITCHH,S ROLLH,S TORQ,C HFORCE	CLRHS/S CXRH/S CYRHS/S	CLRHS/S CXRHS/S CYRHS/S	CMYHS/S CMXHS/S FE	THRUST POW HP VD	CTH/S CP/S CPO/S L/DR
44	0.051	0.031	0.606	2.3	3711	251	0.029976	0.029989	0.000092	3713	0.029989
14	20.5	1.42	294.2	-1.9	-111	-9	0.0009	-0.000147	-0.000003	139009	0.001657
	-2	14.765	677.8	0.6	-90	4512	-0.000728	-0.000728	-78.52	253	0.000952
		0.002369	60.7	2.2	66.7	18				-53	0.95
44	0.051	0.031	0.605	3.8	5010	262	0.04066	0.040676	0.000097	5012	0.040676
15	20.5	1.42	293.5	-2.2	-142	-18	0.001156	-0.000263	-0.000006	180102	0.002162
	-2	14.765	676.2	0.7	-131	5860	-0.001064	-0.001064	-100.47	327	0.000894
		0.002369	60.7	2.8	61.38	32				-52	0.99
44	0.051	0.031	0.606	5.2	6249	243	0.050579	0.050599	0.000089	6251	0.050599
16	20.4	1.41	293.9	-2.3	-178	-4	0.001437	-0.000329	-0.000001	230147	0.002751
	-2	14.765	677.1	0.9	-168	7478	-0.001357	-0.001357	-126.1	418	0.000799
		0.002369	60.7	3.3	57.05	41				-53	0.96
44	0.051	0.031	0.605	6.4	7449	380	0.060331	0.060349	0.00014	7451	0.060349
17	20.4	1.41	293.8	-2.4	-193	-61	0.001565	-0.000542	-0.000022	283294	0.00339
	-2	14.765	676.9	0.9	-218	9208	-0.001764	-0.001764	-137.2	515	0.000638
		0.002369	60.7	3.8	53.63	67				-49	0.93
44	0.051	0.031	0.605	7.7	8796	328	0.071395	0.071419	0.000121	8799	0.071419
18	20.4	1.41	293.5	-2.5	-238	-103	0.001936	-0.000557	-0.000038	348763	0.004186
	-2	14.765	676.2	1.1	-274	11347	-0.002221	-0.002221	-169.37	634	0.000495
		0.002369	60.7	4.4	50.39	69				-52	0.89
44	0.051	0.031	0.605	8.7	9852	431	0.07979	0.079811	0.000159	9855	0.079811
19	20.5	1.42	293.8	-2.5	-248	-126	0.00201	-0.000776	-0.000046	408682	0.00489
	-2	14.766	676.9	1	-322	13283	-0.002607	-0.002607	-175.02	743	0.000529
		0.002369	60.7	4.8	48.35	96				-49	0.85

RUN POINT	V/OR VKTS ALFS,U	MTUN QPSF BARO RHO	MTIP RPM OMEG*R TTEMPF	THETA A1 B1 CONING	LIFTH,C DRAGH,C SIDEH,C SKANGLE	PITCHH,S ROLLH,S TORQ,C HFORCE	CLRH/S CXRH/S CYRH/S	CLRHS/S CXRHS/S CYRHS/S	CMYHS/S CMXHS/S FE	THRUST POW HP VD	CTH/S CP/S CPO/S L/DR
44	0.051	0.031	0.606	10	11255	311	0.09109	0.091121	0.000114	11259	0.091121
20	20.4	1.41	293.9	-2.6	-307	-147	0.002482	-0.000699	-0.000054	499551	0.005971
	-2	14.766	677.1	1.4	-377	16231	-0.003055	-0.003055	-217.77	908	0.000652
		0.002369	60.7	5.4	45.68	86				-53	0.79
44	0.051	0.031	0.608	11.2	12562	472	0.100972	0.100996	0.000173	12565	0.100996
21	20.4	1.41	294.9	-2.6	-303	-86	0.002438	-0.001088	-0.000031	593208	0.007018
	-2	14.766	679.4	1.3	-417	19209	-0.003355	-0.003355	-215.37	1079	0.000811
		0.00237	60.7	5.9	43.64	135				-47	0.74
44	0.051	0.031	0.605	12.4	13654	350	0.110573	0.110613	0.000129	13659	0.110613
22	20.4	1.41	293.8	-2.8	-379	-170	0.003071	-0.00079	-0.000063	691181	0.008269
	-2	14.766	676.9	1.6	-469	22465	-0.003802	-0.003802	-269.33	1257	0.001155
		0.00237	60.7	6.3	42.12	98				-55	0.69
44	0.051	0.031	0.606	13.8	14820	362	0.119888	0.119939	0.000133	14827	0.119939
23	20.4	1.41	293.9	-2.7	-437	-128	0.003537	-0.000649	-0.000047	822161	0.009823
	-2	14.766	677.1	1.9	-492	26713	-0.003983	-0.003983	-310.52	1495	0.001789
		0.002371	60.5	6.8	40.66	80				-59	0.63
48	0.081	0.049	0.605	2.2	4673	86	0.037936	0.037936	0.000032	4673	0.037936
32	32.4	3.58	292.4	-1.9	37	-141	-0.0003	-0.0003	-0.000052	139164	0.001677
	0	14.761	673.6	1	-87	4545	-0.000708	-0.000708	10.32	253	0.001039
		0.002386	56.7	2.7	78.13	37				56	1.81
48	0.081	0.049	0.608	3.7	6242	144	0.050123	0.050123	0.000053	6242	0.050123
33	32.4	3.57	294	-2.3	48	-187	-0.000386	-0.000386	-0.000068	182914	0.002168
	0	14.762	677.3	1.2	-142	5941	-0.001139	-0.001139	13.47	333	0.001036
		0.002387	56.7	3.4	74.5	48				48	1.84

RUN POINT	V/OR VKTS ALFS,U	MTUN QPSF BARO RHO	MTIP RPM OMEG*R TTEMPF	THETA A1 B1 CONING	LIFTH,C DRAGH,C SIDEH,C SKANGLE	PITCHH,S ROLLH,S TORQ,C HFORCE	CLRHS/S CXRHS/S CYRHS/S	CLRHS/S CXRHS/S CYRHS/S	CMYHS/S CMXHS/S FE	THRUST POW HP VD	CTH/S CP/S CPO/S L/DR
48	0.081	0.049	0.605	4.9	7335	196	0.059503	0.059503	0.000072	7335	0.059503
34	32.5	3.59	292.5	-2.4	61	-124	-0.000493	-0.000493	-0.000046	219492	0.002642
	0	14.763	673.9	1.5	-174	7166	-0.001414	-0.001414	16.95	399	0.001055
		0.002387	56.7	3.9	72.25	61				47	1.8
48	0.081	0.049	0.607	6.1	8670	239	0.069915	0.069915	0.000088	8670	0.069915
35	32.5	3.6	293.3	-2.6	81	-148	-0.00065	-0.00065	-0.000054	274869	0.00328
	0	14.763	675.7	1.7	-231	8949	-0.001865	-0.001865	22.42	500	0.001083
		0.002388	56.5	4.4	69.63	81				47	1.7
48	0.081	0.049	0.605	6.7	9219	222	0.074841	0.074841	0.000082	9219	0.074841
36	32.5	3.59	292.3	-2.7	86	-156	-0.000695	-0.000695	-0.000058	301428	0.003634
	0	14.763	673.4	1.8	-255	9848	-0.002071	-0.002071	23.88	548	0.001117
		0.002388	56.4	4.7	68.54	86				46	1.65
63	0.1	0.061	0.606	3.5	3580	99	0.028929	0.02978	0.000036	3686	0.02978
9	40.3	5.49	293.7	-0.7	-878	-198	0.007096	-0.000628	-0.000073	181640	0.002169
	-14.99	14.804	676.6	1	-12	5906	-0.000095	-0.000095	-159.89	330	0.001145
		0.002377	60.1	-0.1	69.28	78				-903	2
63	0.101	0.061	0.605	4.7	4844	22	0.039209	0.040431	0.000008	4995	0.040431
10	40.3	5.49	293.5	-0.9	-1221	-207	0.009881	-0.000597	-0.000076	229052	0.002742
	-14.99	14.804	676.2	1.3	-32	7452	-0.000255	-0.000255	-222.24	416	0.001176
		0.002376	60.3	0.4	67.43	74				-946	2.26
63	0.101	0.061	0.605	5.8	6026	45	0.048786	0.050346	0.000017	6218	0.050346
11	40.4	5.52	293.5	-1.2	-1538	-255	0.012449	-0.000593	-0.000094	280360	0.003357
	-14.99	14.803	676.2	1.6	-62	9122	-0.000501	-0.000501	-278.37	510	0.001219
		0.002375	60.4	0.9	65.83	73				-971	2.34

RUN POINT	V/OR VKTS ALFS,U	MTUN QPSF BARO RHO	MTIP RPM OMEG*R TTEMPF	THETA A1 B1 CONING	LIFTH,C DRAGH,C SIDEH,C SKANGLE	PITCHH,S ROLLH,S TORQ,C HFORCE	CLRH/S CXRH/S CYRH/S	CLRHS/S CXRHS/S CYRHS/S	CMYHS/S CMXHS/S FE	THRUST POW HP VD	CTH/S CP/S CPO/S L/DR
63	0.101	0.061	0.606	6.9	7257	181	0.058501	0.060376	0.000066	7490	0.060376
12	40.4	5.51	294.1	-1.4	-1854	-341	0.014946	-0.000705	-0.000125	338005	0.004021
	-15	14.804	677.6	1.7	-107	10975	-0.000862	-0.000862	-336.28	615	0.001246
		0.002376	60.3	1.4	64.2	87				-978	2.34
63	0.101	0.061	0.604	7.9	8388	254	0.068145	0.070326	0.000094	8656	0.070326
13	40.4	5.51	292.9	-1.5	-2141	-325	0.017397	-0.000833	-0.00012	397451	0.004785
	-15	14.803	674.8	2	-142	12958	-0.001153	-0.001153	-388.38	723	0.001309
		0.002377	60.1	1.9	62.8	103				-982	2.27
63	0.101	0.061	0.605	9	9613	205	0.077795	0.080332	0.000075	9926	0.080332
14	40.3	5.5	293.4	-1.8	-2477	-418	0.020044	-0.000774	-0.000154	471405	0.005644
	-15	14.804	675.9	2.3	-201	15343	-0.001627	-0.001627	-450.04	857	0.001378
		0.002378	59.9	2.4	61.33	96				-993	2.16
63	0.1	0.061	0.607	10.1	10857	278	0.087359	0.090203	0.000102	11210	0.090203
15	40.3	5.5	294.2	-1.9	-2795	-362	0.022488	-0.000888	-0.000132	552154	0.006555
	-15	14.803	677.8	2.5	-243	17922	-0.001952	-0.001952	-507.86	1004	0.001454
		0.002378	59.7	2.9	59.94	110				-995	2.04
63	0.101	0.061	0.606	11.2	11996	332	0.096788	0.09993	0.000122	12385	0.09993
16	40.4	5.53	293.8	-2.1	-3084	-322	0.024881	-0.001017	-0.000118	638535	0.007612
	-15	14.803	676.9	2.7	-281	20754	-0.002271	-0.002271	-557.24	1161	0.001628
		0.002378	59.7	3.4	58.81	126				-998	1.91
63	0.101	0.061	0.604	12.4	13082	342	0.106308	0.109795	0.000126	13512	0.109795
17	40.4	5.53	292.7	-2.3	-3381	-378	0.027471	-0.000979	-0.000139	729128	0.008786
	-15	14.803	674.3	2.9	-340	23788	-0.002765	-0.002765	-610.9	1326	0.001829
		0.002379	59.5	3.9	57.72	121				-1005	1.79

RUN POINT	V/OR VKTS ALFS,U	MTUN QPSF BARO RHO	MTIP RPM OMEG*R TTEMPF	THETA A1 B1 CONING	LIFTH,C DRAGH,C SIDEH,C SKANGLE	PITCHH,S ROLLH,S TORQ,C HFORCE	CLRH/S CXRH/S CYRH/S	CLRHS/S CXRHS/S CYRHS/S	CMYHS/S CMXHS/S FE	THRUST POW HP VD	CTH/S CP/S CPO/S L/DR
63	0.1	0.061	0.607	14.1	14374	446	0.115692	0.119581	0.000163	14857	0.119581
18	40.3	5.5	294.1	-2.3	-3759	-543	0.030256	-0.000718	-0.000199	892188	0.010598
	-15	14.803	677.6	3.3	-408	28969	-0.003282	-0.003282	-683.09	1622	0.002574
		0.002379	59.5	4.4	56.41	89				-1015	1.54
45	0.099	0.06	0.608	2.8	3713	-89	0.029811	0.030156	-0.000032	3756	0.030156
5	39.8	5.37	294.7	-0.9	-573	-165	0.004597	-0.000649	-0.00006	162237	0.001919
	-10	14.77	678.9	1.1	-37	5257	-0.000296	-0.000296	-106.62	295	0.001128
		0.002376	59.1	2.2	73.82	81				-547	2.02
45	0.099	0.06	0.607	3.9	4894	-34	0.039483	0.039968	-0.000013	4954	0.039968
6	39.8	5.37	294	-1.2	-774	-162	0.006244	-0.000707	-0.000059	197452	0.002352
	-10	14.771	677.3	1.2	-58	6413	-0.000465	-0.000465	-144.12	359	0.001145
		0.002375	59.2	2.7	71.99	88				-579	2.26
45	0.1	0.06	0.606	5.1	6166	90	0.049894	0.050515	0.000033	6242	0.050515
7	39.9	5.39	293.6	-1.6	-982	-234	0.007946	-0.000838	-0.000086	241997	0.002895
	-10	14.771	676.4	1.4	-96	7871	-0.000777	-0.000777	-182.17	440	0.001169
		0.002375	59.3	3.3	70.15	104				-595	2.36
45	0.1	0.06	0.604	6.2	7377	138	0.059999	0.060762	0.000051	7471	0.060762
8	40	5.4	292.8	-1.6	-1186	-266	0.009644	-0.000922	-0.000098	291836	0.003519
	-10	14.771	674.6	1.7	-137	9518	-0.001116	-0.001116	-219.54	531	0.001208
		0.002376	59.1	3.8	68.47	113				-608	2.35
45	0.1	0.06	0.604	7.2	8548	130	0.06957	0.070472	0.000048	8659	0.070472
9	40	5.41	292.7	-1.8	-1386	-250	0.011279	-0.000973	-0.000092	348057	0.004201
	-10	14.771	674.3	2	-176	11355	-0.001436	-0.001436	-256.12	633	0.001263
		0.002376	59.1	4.3	66.93	120				-618	2.27

RUN POINT	V/OR VKTS ALFS,U	MTUN QPSF BARO RHO	MTIP RPM OMEG*R TTEMPF	THETA A1 B1 CONING	LIFTH,C DRAGH,C SIDEH,C SKANGLE	PITCHH,S ROLLH,S TORQ,C HFORCE	CLRH/S CXRH/S CYRH/S	CLRHS/S CXRHS/S CYRHS/S	CMYHS/S CMXHS/S FE	THRUST POW HP VD	CTH/S CP/S CPO/S L/DR
45	0.1	0.061	0.605	8.5	9857	117	0.079986	0.081048	0.000043	9988	0.081048
10	40	5.42	293.1	-2.1	-1616	-365	0.013112	-0.000977	-0.000135	419076	0.005036
	-10	14.772	675.3	2.2	-249	13654	-0.002024	-0.002024	-298.07	762	0.001332
		0.002376	59	4.9	65.29	120				-630	2.15
45	0.1	0.061	0.604	9.5	10916	177	0.088857	0.090024	0.000066	11059	0.090024
11	40	5.42	292.6	-2.2	-1781	-295	0.014499	-0.001151	-0.000109	482035	0.005821
	-10	14.772	674.1	2.4	-285	15732	-0.002319	-0.002319	-328.54	876	0.001421
		0.002377	58.9	5.4	64.02	141				-629	2.04
45	0.1	0.061	0.605	10.7	12234	96	0.099163	0.100513	0.000036	12400	0.100513
12	40	5.42	293.2	-2.6	-2029	-422	0.016447	-0.001022	-0.000155	576992	0.006924
	-10	14.772	675.5	2.7	-369	18792	-0.002994	-0.002994	-374.29	1049	0.001601
		0.002377	58.7	5.9	62.51	126				-642	1.88
45	0.1	0.061	0.605	12	13364	179	0.108541	0.110049	0.000066	13549	0.110049
13	40	5.43	292.9	-2.7	-2238	-444	0.01818	-0.000944	-0.000164	683095	0.008222
	-10	14.773	674.8	3.1	-429	22271	-0.003481	-0.003481	-412.11	1242	0.002002
		0.002377	58.7	6.3	61.31	116				-651	1.7
45	0.1	0.061	0.606	13.6	14596	236	0.118274	0.120002	0.000087	14809	0.120002
14	40.1	5.45	293.3	-2.8	-2505	-533	0.020301	-0.000546	-0.000196	836659	0.010033
	-10	14.773	675.7	3.6	-481	27240	-0.003899	-0.003899	-459.53	1521	0.002779
		0.002376	58.9	6.8	60.08	67				-670	1.48
44	0.102	0.061	0.604	2.2	4644	148	0.037868	0.037875	0.000055	4645	0.037875
6	40.6	5.56	292.9	-1.5	-105	-97	0.00086	-0.000462	-0.000036	107629	0.001301
	-2	14.763	674.8	1	-78	3509	-0.000639	-0.000639	-18.96	196	0.000685
		0.002368	60.4	2.6	80.33	57				-34	3.17

RUN POINT	V/OR VKTS ALFS,U	MTUN QPSF BARO RHO	MTIP RPM OMEG*R TTEMPF	THETA A1 B1 CONING	LIFTH,C DRAGH,C SIDEH,C SKANGLE	PITCHH,S ROLLH,S TORQ,C HFORCE	CLRH/S CXRH/S CYRH/S	CLRHS/S CXRHS/S CYRHS/S	CMYHS/S CMXHS/S FE	THRUST POW HP VD	CTH/S CP/S CPO/S L/DR
44	0.101	0.061	0.605	2.6	5052	170	0.040991	0.040999	0.000063	5053	0.040999
7	40.7	5.57	293.6	-1.5	-117	-71	0.000951	-0.00048	-0.000026	121796	0.001461
	-2	14.763	676.4	1.2	-86	3961	-0.000697	-0.000697	-21.02	221	0.000745
		0.002368	60.3	2.8	79.7	59				-41	3.05
44	0.101	0.061	0.607	3.7	6176	215	0.049896	0.04991	0.000079	6178	0.04991
8	40.6	5.56	294.3	-1.9	-156	-107	0.001264	-0.000478	-0.000039	161496	0.001924
	-2	14.763	678	1.3	-126	5240	-0.001018	-0.001018	-28.12	294	0.000876
		0.002367	60.5	3.3	77.94	59				-60	2.81
44	0.101	0.061	0.605	4.8	7449	187	0.060478	0.060499	0.000069	7451	0.060499
9	40.6	5.56	293.5	-2.1	-204	-136	0.001654	-0.000458	-0.000005	204859	0.00246
	-2	14.764	676.2	1.7	-176	6665	-0.001426	-0.001426	-36.61	372	0.000943
		0.002368	60.3	3.8	76.03	56				-76	2.67
44	0.101	0.061	0.606	5.9	8695	282	0.070501	0.070523	0.000104	8698	0.070523
10	40.7	5.57	293.7	-2.3	-230	-120	0.001861	-0.00006	-0.000044	250552	0.003002
	-2	14.764	676.6	2	-222	8146	-0.001802	-0.001802	-41.18	456	0.000981
		0.002368	60.3	4.4	74.25	74				-77	2.54
44	0.101	0.061	0.606	7.1	9926	226	0.080378	0.080408	0.000083	9930	0.080408
11	40.6	5.56	293.9	-2.4	-280	-141	0.002267	-0.00054	-0.000052	307814	0.003681
	-2	14.764	677.1	2.3	-285	10001	-0.002304	-0.002304	-50.31	560	0.001065
		0.002368	60.3	4.9	72.51	67				-88	2.36
44	0.101	0.061	0.607	8.3	11149	266	0.090038	0.090072	0.000098	11153	0.090072
12	40.7	5.59	294.3	-2.8	-317	-198	0.002563	-0.000581	-0.000073	372518	0.004437
	-2	14.764	678	2.5	-362	12087	-0.00292	-0.00292	-56.82	677	0.001184
		0.002368	60.3	5.4	70.93	72				-93	2.18

RUN POINT	V/OR VKTS ALFS,U	MTUN QPSF BARO RHO	MTIP RPM OMEG*R TTEMPF	THETA A1 B1 CONING	LIFTH,C DRAGH,C SIDEH,C SKANGLE	PITCHH,S ROLLH,S TORQ,C HFORCE	CLRHS/S CXRHS/S CYRHS/S	CLRH/S CXRH/S CYRH/S	CMYHS/S CMXHS/S FE	THRUST POW HP VD	CTH/S CP/S CPO/S L/D
44	0.101	0.061	0.606	9.3	12354	358	0.099976	0.10001	0.000132	12359	0.10001
13	40.7	5.59	294	-2.9	-336	-146	0.002721	-0.000769	-0.000054	443105	0.005294
	-2	14.764	677.3	2.7	-420	14392	-0.003397	-0.003397	-60.21	806	0.001331
		0.002368	60.3	5.9	69.4	95				-90	2.02
46	0.1	0.061	0.605	4.6	8597	172	0.069567	0.069881	0.000063	8636	0.069881
5	40	5.44	292.7	-2.5	821	-112	-0.006646	-0.000558	-0.000041	177815	0.002134
	5	14.788	674.3	1.8	-198	5801	-0.0016	-0.0016	150.92	323	0.000991
		0.002389	56.9	4.5	80.26	69				415	2.49
46	0.1	0.061	0.605	8	12273	299	0.099326	0.099769	0.00011	12328	0.099769
6	40	5.44	292.7	-3.4	1165	-229	-0.009425	-0.000732	-0.000084	324137	0.00389
	5	14.787	674.3	2.5	-406	10575	-0.003285	-0.003285	214	589	0.001147
		0.002389	56.9	6.1	74.65	90				404	2.06
46	0.1	0.061	0.606	2.3	6143	51	0.049601	0.049816	0.000019	6170	0.049816
7	40.1	5.48	292.9	-1.9	574	-21	-0.004632	-0.000292	-0.000008	120236	0.001439
	5	14.788	674.8	1.4	-102	3920	-0.000826	-0.000826	104.64	219	0.000987
		0.002391	56.5	3.4	84.4	36				421	2.61
46	0.101	0.061	0.605	3.4	7402	192	0.059917	0.060181	0.000071	7435	0.060181
8	40.2	5.49	292.5	-2.2	697	-104	-0.005638	-0.000395	-0.000038	145068	0.001743
	5	14.788	673.9	1.5	-155	4736	-0.001255	-0.001255	126.82	264	0.000974
		0.002392	56.4	4	82.33	49				417	2.61
46	0.1	0.061	0.606	4.6	8604	138	0.069534	0.069827	0.000051	8640	0.069827
9	40.1	5.47	292.7	-2.6	792	-148	-0.006401	-0.000316	-0.000054	178690	0.002142
	5	14.788	674.3	1.8	-209	5830	-0.001692	-0.001692	144.73	325	0.000981
		0.002392	56.3	4.5	80.33	39				403	2.51

RUN POINT	V/OR VKTS ALFS,U	MTUN QPSF BARO RHO	MTIP RPM OMEG*R TTEMPF	THETA A1 B1 CONING	LIFTH,C DRAGH,C SIDEH,C SKANGLE	PITCHH,S ROLLH,S TORQ,C HFORCE	CLRH/S CXRH/S CYRH/S	CLRHS/S CXRHS/S CYRHS/S	CMYHS/S CMXHS/S FE	THRUST POW HP VD	CTH/S CP/S CPO/S L/DR
46	0.101	0.061	0.605	5.7	9810	239	0.079524	0.079865	0.000088	9852	0.079865
10	40.1	5.48	292.2	-3	910	-134	-0.007379	-0.00042	-0.00005	218010	0.002625
	5	14.788	673.2	2.1	-261	7125	-0.002116	-0.002116	166.04	396	0.001015
		0.002393	56.1	5	78.46	52				402	2.37
47	0.101	0.061	0.604	3.5	8455	-44	0.068796	0.070013	-0.000016	8604	0.070013
5	40	5.46	291.1	-2.4	1602	-236	-0.013032	-0.000887	-0.000087	109694	0.001331
	10	14.786	670.6	1.4	-143	3598	-0.001163	-0.001163	293.2	199	0.000881
		0.002402	54.1	4.6	84.88	109				783	2.62
47	0.1	0.061	0.605	4.7	9779	-54	0.079215	0.080596	-0.00002	9949	0.080596
6	39.9	5.46	291.7	-2.7	1838	-241	-0.014886	-0.000904	-0.000089	142801	0.001721
	10	14.786	672	1.6	-193	4675	-0.001564	-0.001564	336.42	260	0.000876
		0.002403	53.9	5.2	82.6	112				773	2.47
47	0.1	0.061	0.606	5.7	10953	80	0.088574	0.090138	0.000029	11147	0.090138
7	39.9	5.46	291.9	-3	2072	-355	-0.016757	-0.001121	-0.00013	177659	0.002136
	10	14.786	672.5	1.8	-266	5812	-0.002149	-0.002149	379.37	323	0.000889
		0.002404	53.7	5.7	80.63	139				775	2.33
47	0.1	0.061	0.606	7.1	12318	29	0.099494	0.101203	0.000011	12530	0.101203
8	40	5.46	292.2	-3.4	2297	-246	-0.018549	-0.000099	-0.00009	233260	0.002799
	10	14.786	673.2	2.3	-320	7623	-0.002584	-0.002584	420.44	424	0.000961
		0.002402	54.1	6.3	78.43	123				762	2.14
49	0.1	0.061	0.605	3.6	8528	-100	0.069145	0.070314	-0.000037	8672	0.070314
5	39.9	5.45	291.5	-2.5	1576	-107	-0.012779	-0.000578	-0.000039	115237	0.001391
	10	14.778	671.6	1.5	-172	3775	-0.001397	-0.001397	289.1	210	0.00089
		0.002404	53.5	4.6	84.73	71				764	2.59

RUN POINT	V/OR VKTS ALFS,U	MTUN QPSF BARO RHO	MTIP RPM OMEG*R TTEMPF	THETA A1 B1 CONING	LIFTH,C DRAGH,C SIDEH,C SKANGLE	PITCHH,S ROLLH,S TORQ,C HFORCE	CLRH/S CXRH/S CYRH/S	CLRHS/S CXRHS/S CYRHS/S	CMYHS/S CMXHS/S FE	THRUST POW HP VD	CTH/S CP/S CPO/S L/DR
49	0.1	0.061	0.606	6.9	12156	64	0.098228	0.099873	0.000024	12360	0.099873
6	39.9	5.44	292	-3.4	2236	-210	-0.018067	-0.000736	-0.000077	228573	0.002746
	10	14.778	672.7	2.3	-367	7475	-0.002963	-0.002963	410.88	416	0.000944
		0.002404	53.5	6.2	78.63	91				751	2.16
49	0.1	0.061	0.606	3.5	8451	-53	0.068393	0.069544	-0.00002	8594	0.069544
7	39.9	5.44	291.8	-2.4	1558	-56	-0.012611	-0.000543	-0.000021	113646	0.001368
	10	14.777	672.3	1.5	-163	3719	-0.001319	-0.001319	286.37	207	0.000882
		0.002404	53.5	4.6	84.84	67				762	2.6
49	0.1	0.06	0.606	4.6	9713	85	0.07855	0.079887	0.000031	9879	0.079887
8	39.8	5.42	291.9	-2.7	1802	-104	-0.014571	-0.00071	-0.000038	142780	0.001717
	10	14.777	672.5	1.7	-219	4671	-0.001771	-0.001771	332.36	260	0.000861
		0.002404	53.5	5.2	82.59	88				761	2.47
49	0.1	0.06	0.606	5.7	10832	24	0.087542	0.088993	0.000009	11011	0.088993
9	39.8	5.42	292	-3.1	1981	-148	-0.016011	-0.000567	-0.000054	178890	0.002149
	10	14.776	672.7	2	-282	5850	-0.002277	-0.002277	365.44	325	0.000877
		0.002404	53.5	5.7	80.72	70				748	2.33
49	0.1	0.06	0.607	6.8	12145	175	0.097884	0.09953	0.000064	12350	0.09953
10	39.8	5.41	292.4	-3.4	2239	-163	-0.018043	-0.000772	-0.00006	227101	0.002717
	10	14.777	673.6	2.3	-354	7417	-0.002854	-0.002854	413.76	413	0.000916
		0.002404	53.5	6.2	78.53	96				750	2.16
49	0.1	0.06	0.607	8	13381	215	0.107917	0.109717	0.000079	13604	0.109717
11	39.8	5.41	292.3	-3.6	2456	-185	-0.019808	-0.000768	-0.000068	283906	0.0034
	10	14.777	673.4	2.5	-439	9275	-0.003544	-0.003544	453.92	516	0.001002
		0.002404	53.5	6.8	76.6	95				745	2

RUN POINT	V/OR VKTS ALFS,U	MTUN QPSF BARO RHO	MTIP RPM OMEG*R TTEMPF	THETA A1 B1 CONING	LIFTH,C DRAGH,C SIDEH,C SKANGLE	PITCHH,S ROLLH,S TORQ,C HFORCE	CLRH/S CXRH/S CYRH/S	CLRHS/S CXRHS/S CYRHS/S	CMYHS/S CMXHS/S FE	THRUST POW HP VD	CTH/S CP/S CPO/S L/DR
49	0.1	0.06	0.606	9.2	14577	202	0.117841	0.119753	0.000074	14814	0.119753
12	39.7	5.4	291.9	-3.9	2638	-92	-0.021322	-0.000536	-0.000034	355725	0.004276
	10	14.777	672.5	2.9	-513	11637	-0.00415	-0.00415	488.4	647	0.001189
		0.002405	53.3	7.3	74.77	66				733	1.83
26	0.124	0.075	0.605	2.2	6588	139	0.054041	0.054297	0.000052	6619	0.054297
12	49.5	8.26	292.2	-1.8	647	-154	-0.005305	-0.000575	-0.000058	101479	0.001237
	5	14.634	673.2	1.4	-123	3316	-0.001012	-0.001012	78.29	185	0.001016
		0.002365	55.7	3.6	87.42	70				564	3.54
26	0.124	0.075	0.605	2.8	7304	103	0.060055	0.060327	0.000038	7337	0.060327
13	49.5	8.25	291.9	-1.7	699	58	-0.005744	-0.000488	0.000022	112694	0.001378
	5	14.634	672.5	1.7	-125	3687	-0.001032	-0.001032	84.68	205	0.001005
		0.002365	55.8	4	86.59	59				544	3.57
26	0.124	0.075	0.605	3.9	8456	131	0.069397	0.069705	0.000049	8494	0.069705
14	49.5	8.25	292.2	-2.1	800	-67	-0.006565	-0.000492	-0.000025	134596	0.001641
	5	14.634	673.2	1.9	-182	4399	-0.001495	-0.001495	96.96	245	0.001004
		0.002364	55.9	4.5	85.28	60				530	3.51
26	0.124	0.075	0.605	4.9	9714	243	0.079685	0.080041	0.000091	9758	0.080041
15	49.5	8.27	292.2	-2.3	923	0	-0.007573	-0.000599	0	164433	0.002004
	5	14.635	673.2	2.3	-221	5374	-0.001813	-0.001813	111.61	299	0.001033
		0.002365	55.7	5	83.9	73				525	3.36
26	0.124	0.075	0.605	6.1	10949	236	0.08984	0.090229	0.000088	10996	0.090229
16	49.5	8.26	291.8	-2.6	1022	-10	-0.008388	-0.000526	-0.000004	203791	0.002487
	5	14.636	672.3	2.7	-279	6669	-0.002288	-0.002288	123.74	371	0.001098
		0.002371	54.6	5.6	82.53	64				510	3.16

RUN POINT	V/OR VKTS ALFS,U	MTUN QPSF BARO RHO	MTIP RPM OMEG*R TTEMPF	THETA A1 B1 CONING	LIFTH,C DRAGH,C SIDEH,C SKANGLE	PITCHH,S ROLLH,S TORQ,C HFORCE	CLRH/S CXRH/S CYRH/S	CLRHS/S CXRHS/S CYRHS/S	CMYHS/S CMXHS/S FE	THRUST POW HP VD	CTH/S CP/S CPO/S L/DR
26	0.124	0.075	0.605	7.1	12160	315	0.099871	0.100309	0.000118	12214	0.100309
17	49.5	8.26	291.7	-2.8	1143	-13	-0.009391	-0.000651	-0.000005	245510	0.003
	5	14.636	672	2.9	-341	8037	-0.002804	-0.002804	138.42	446	0.001164
		0.00237	54.7	6.2	81.21	79				509	2.98
26	0.124	0.075	0.605	8.3	13400	230	0.110145	0.110601	0.000086	13456	0.110601
18	49.5	8.25	291.7	-3.2	1222	-60	-0.010041	-0.000403	-0.000022	302319	0.003698
	5	14.636	672	3.4	-431	9897	-0.003544	-0.003544	148.06	550	0.001292
		0.002368	55.1	6.7	79.88	49				491	2.77
29	0.125	0.076	0.606	2.8	7404	40	0.060071	0.060347	0.000015	7438	0.060347
5	50.1	8.51	293.1	-1.8	714	-146	-0.005791	-0.000533	-0.000054	110428	0.001327
	5	14.763	675.3	1.7	-136	3598	-0.001107	-0.001107	83.9	201	0.000975
		0.002377	57.9	4	86.73	66				556	3.67
29	0.125	0.076	0.604	3.8	8513	177	0.069394	0.069715	0.000066	8552	0.069715
6	50.1	8.49	292.4	-1.9	823	-44	-0.006713	-0.000639	-0.000016	129595	0.001568
	5	14.763	673.6	1.9	-164	4232	-0.001334	-0.001334	97.03	236	0.000975
		0.002377	57.9	4.5	85.49	78				548	3.61
29	0.125	0.076	0.607	4.9	9852	146	0.07966	0.080014	0.000054	9896	0.080014
7	50.1	8.5	293.6	-2.4	932	-216	-0.007537	-0.000565	-0.000079	163361	0.001953
	5	14.762	676.4	2.3	-243	5313	-0.001962	-0.001962	109.7	297	0.000997
		0.002377	57.9	5.1	84.04	70				530	3.44
29	0.125	0.076	0.605	6	10992	222	0.089378	0.089774	0.000082	11041	0.089774
8	50.1	8.49	292.8	-2.7	1038	-237	-0.008442	-0.00062	-0.000088	195587	0.002358
	5	14.761	674.6	2.5	-303	6379	-0.002463	-0.002463	122.34	356	0.00103
		0.002376	57.9	5.6	82.8	76				523	3.28

RUN POINT	V/OR VKTS ALFS,U	MTUN QPSF BARO RHO	MTIP RPM OMEG*R TTEMPF	THETA A1 B1 CONING	LIFTH,C DRAGH,C SIDEH,C SKANGLE	PITCHH,S ROLLH,S TORQ,C HFORCE	CLRH/S CXRH/S CYRH/S	CLRHS/S CXRHS/S CYRHS/S	CMYHS/S CMXHS/S FE	THRUST POW HP VD	CTH/S CP/S CPO/S L/DR
29	0.125	0.076	0.606	7.1	12275	128	0.099581	0.099992	0.000047	12326	0.099992
9	50.1	8.49	293.1	-2.9	1117	-180	-0.009063	-0.00035	-0.000066	244203	0.002934
	5	14.762	675.3	3	-364	7956	-0.002954	-0.002954	131.65	444	0.001104
		0.002377	57.8	6.2	81.44	43				501	3.06
29	0.125	0.076	0.605	6.1	11112	192	0.090369	0.090746	0.000071	11158	0.090746
10	50	8.47	292.7	-2.8	1018	-166	-0.008278	-0.00037	-0.000061	200885	0.002423
	5	14.762	674.3	2.7	-309	6554	-0.002512	-0.002512	120.23	365	0.001018
		0.002377	57.7	5.7	82.65	46				508	3.27
29	0.125	0.076	0.605	6.1	11132	148	0.090685	0.091056	0.000055	11178	0.091056
11	50	8.48	292.4	-2.8	1009	-185	-0.008221	-0.000286	-0.000068	201663	0.002439
	5	14.762	673.6	2.7	-316	6586	-0.002577	-0.002577	119.07	367	0.001015
		0.002378	57.5	5.7	82.64	35				503	3.28
29	0.125	0.076	0.604	6.1	11105	143	0.090533	0.090904	0.000053	11150	0.090904
12	50	8.48	292.2	-2.8	1007	-181	-0.008209	-0.000287	-0.000067	202727	0.002455
	5	14.761	673.2	2.7	-315	6625	-0.002568	-0.002568	118.79	369	0.00104
		0.00238	57.2	5.7	82.67	35				503	3.26
30	0.125	0.076	0.605	2.2	7749	-86	0.06327	0.064353	-0.000032	7882	0.064353
5	49.9	8.38	293.1	-1.6	1442	-72	-0.011772	-0.000595	-0.000027	59493	0.000719
	10.01	14.703	675.3	1.5	-129	1938	-0.001055	-0.001055	171.98	108	0.000988
		0.002362	59.1	4.3	90.98	73				987	3.61
30	0.125	0.076	0.606	2.8	8511	-18	0.069208	0.070391	-0.000007	8657	0.070391
6	49.9	8.38	293.7	-1.8	1582	-133	-0.012867	-0.000641	-0.000049	65399	0.000786
	10.01	14.703	676.6	1.6	-160	2126	-0.001302	-0.001302	188.73	119	0.00095
		0.002362	59.1	4.6	90.08	79				981	3.61

RUN POINT	V/OR VKTS ALFS,U	MTUN QPSF BARO RHO	MTIP RPM OMEG*R TTEMPF	THETA A1 B1 CONING	LIFTH,C DRAGH,C SIDEH,C SKANGLE	PITCHH,S ROLLH,S TORQ,C HFORCE	CLRH/S CXRH/S CYRH/S	CLRHS/S CXRHS/S CYRHS/S	CMYHS/S CMXHS/S FE	THRUST POW HP VD	CTH/S CP/S CPO/S L/DR
30	0.125	0.075	0.605	3.7	9628	83	0.07871	0.080061	0.000031	9793	0.080061
7	49.9	8.36	292.9	-2	1794	-101	-0.014665	-0.00076	-0.000038	78111	0.000946
	10.01	14.704	674.8	1.7	-189	2547	-0.001542	-0.001542	214.48	142	0.000917
		0.002362	59.1	5.2	88.74	93				975	3.54
30	0.124	0.075	0.606	4.7	10910	208	0.088806	0.090345	0.000077	11099	0.090345
8	49.9	8.36	293.5	-2.2	2043	-82	-0.016632	-0.000943	-0.00003	99161	0.001194
	10.01	14.705	676.2	1.8	-233	3226	-0.001896	-0.001896	244.31	180	0.000893
		0.002362	59	5.7	87.24	116				973	3.39
30	0.125	0.076	0.605	5.7	11984	155	0.097995	0.099661	0.000058	12188	0.099661
9	49.9	8.38	292.8	-2.6	2222	-137	-0.018167	-0.000857	-0.000051	124254	0.001506
	10.01	14.706	674.6	2.2	-293	4052	-0.002393	-0.002393	265.01	226	0.000899
		0.002363	58.9	6.2	86.03	105				962	3.24
30	0.124	0.075	0.607	6.8	13314	85	0.107978	0.10977	0.000031	13535	0.10977
10	49.9	8.37	294	-2.8	2437	-151	-0.019765	-0.000695	-0.000056	167349	0.002004
	10.01	14.706	677.3	2.6	-361	5436	-0.002928	-0.002928	291.03	304	0.000952
		0.002363	58.9	6.8	84.5	86				946	3.01
30	0.125	0.075	0.604	8	14576	256	0.119249	0.121272	0.000095	14823	0.121272
11	49.9	8.38	292.6	-3	2699	-84	-0.022083	-0.001019	-0.000031	210065	0.002549
	10.01	14.706	674.1	2.9	-410	6856	-0.003357	-0.003357	321.95	382	0.00105
		0.002365	58.5	7.4	83.1	125				953	2.81
63	0.151	0.091	0.604	4.4	3662	277	0.029801	0.030681	0.000103	3770	0.030681
19	60.3	12.31	292.7	-0.4	-900	-247	0.007322	-0.000641	-0.000091	206716	0.002495
	-15	14.802	674.3	1.6	-10	6744	-0.000083	-0.000083	-73.06	376	0.001169
		0.002376	59.3	-0.1	72.29	79				-1229	3.24

RUN POINT	V/OR VKTS ALFS,U	MTUN QPSF BARO RHO	MTIP RPM OMEG*R TTEMPF	THETA A1 B1 CONING	LIFTH,C DRAGH,C SIDEH,C SKANGLE	PITCHH,S ROLLH,S TORQ,C HFORCE	CLRH/S CXRH/S CYRH/S	CLRHS/S CXRHS/S CYRHS/S	CMYHS/S CMXHS/S FE	THRUST POW HP VD	CTH/S CP/S CPO/S L/DR
63	0.15	0.091	0.605	5.4	4866	235	0.039506	0.040739	0.000087	5018	0.040739
20	60.1	12.24	293	-0.7	-1228	-172	0.009966	-0.000599	-0.000064	257166	0.003093
	-15	14.802	675	2	-25	8381	-0.000205	-0.000205	-100.27	468	0.001206
		0.002377	59.1	0.4	71.41	74				-1320	3.73
63	0.151	0.091	0.604	6.4	5964	95	0.048655	0.050253	0.000035	6160	0.050253
21	60.2	12.28	292.3	-0.9	-1542	-298	0.01258	-0.000441	-0.000111	308672	0.003739
	-15	14.802	673.4	2.6	-60	10084	-0.000486	-0.000486	-125.54	561	0.001254
		0.002377	59.1	0.9	70.64	54				-1389	3.99
63	0.151	0.091	0.604	7.3	7192	254	0.058593	0.060507	0.000094	7427	0.060507
22	60.3	12.3	292.5	-1	-1854	-307	0.015107	-0.000573	-0.000114	368748	0.004458
	-15	14.802	673.9	2.8	-90	12039	-0.000733	-0.000733	-150.71	670	0.001327
		0.002376	59.1	1.4	69.81	70				-1410	4.06
63	0.151	0.091	0.605	8.4	8377	262	0.06814	0.070393	0.000097	8654	0.070393
23	60.4	12.34	292.8	-1.3	-2173	-386	0.017679	-0.000559	-0.000143	437680	0.005278
	-15	14.801	674.6	3.1	-136	14274	-0.001105	-0.001105	-176.07	796	0.001457
		0.002375	59.3	1.9	69.03	69				-1437	3.95
63	0.15	0.091	0.607	9.4	9585	183	0.077394	0.080009	0.000067	9909	0.080009
24	60.2	12.28	293.8	-1.6	-2513	-427	0.020293	-0.00043	-0.000157	512259	0.006111
	-15	14.803	676.9	3.4	-183	16650	-0.001474	-0.001474	-204.61	931	0.001571
		0.002377	59.1	2.4	68.2	53				-1462	3.8
63	0.151	0.091	0.605	10.6	10797	245	0.087803	0.090769	0.000091	11162	0.090769
25	60.4	12.37	292.7	-1.8	-2831	-307	0.023021	-0.000488	-0.000113	592137	0.007141
	-15	14.803	674.3	3.8	-210	19318	-0.001711	-0.001711	-228.95	1077	0.001753
		0.002378	58.9	2.9	67.47	60				-1475	3.63

RUN POINT	V/OR VKTS ALFS,U	MTUN QPSF BARO RHO	MTIP RPM OMEG*R TTEMPF	THETA A1 B1 CONING	LIFTH,C DRAGH,C SIDEH,C SKANGLE	PITCHH,S ROLLH,S TORQ,C HFORCE	CLRH/S CXRH/S CYRH/S	CLRHS/S CXRHS/S CYRHS/S	CMYHS/S CMXHS/S FE	THRUST POW HP VD	CTH/S CP/S CPO/S L/DR
63	0.151	0.092	0.605	11.7	12005	324	0.097567	0.100854	0.00012	12410	0.100854
26	60.5	12.41	292.8	-2.1	-3143	-375	0.025544	-0.000579	-0.000139	679942	0.008192
	-15	14.802	674.6	4	-278	22175	-0.002257	-0.002257	-253.35	1236	0.001972
		0.002377	58.9	3.4	66.74	71				-1483	3.42
63	0.152	0.092	0.604	12.8	13160	286	0.10708	0.110735	0.000106	13609	0.110735
27	60.6	12.44	292.6	-2.5	-3468	-379	0.028217	-0.000459	-0.00014	770894	0.009305
	-15	14.802	674.1	4.3	-340	25159	-0.002764	-0.002764	-278.84	1402	0.002197
		0.002378	58.8	3.9	66.05	56				-1501	3.23
21	0.151	0.092	0.606	3.1	3760	208	0.030472	0.030861	0.000077	3808	0.030861
23	60.1	12.37	291.6	-0.7	-605	-129	0.004907	-0.000464	-0.000047	169600	0.002046
	-10.01	14.776	671.8	1.7	-51	5554	-0.000414	-0.000414	-48.97	308	0.001075
		0.002404	52.3	2.3	77.19	57				-734	3.53
21	0.151	0.091	0.606	4.1	4878	238	0.039591	0.040117	0.000088	4942	0.040117
24	60	12.33	291.2	-0.8	-800	-88	0.006491	-0.000489	-0.000033	204206	0.002471
	-10.01	14.775	670.9	1.9	-69	6696	-0.000562	-0.000562	-64.84	371	0.001103
		0.002407	51.7	2.8	76.37	60				-804	4.01
21	0.151	0.092	0.607	5.2	6158	246	0.049692	0.050374	0.000009	6242	0.050374
25	60	12.37	291.9	-1	-1025	-21	0.008275	-0.000489	-0.000008	250019	0.003
	-10.01	14.775	672.5	2.3	-88	8179	-0.000712	-0.000712	-82.93	455	0.00114
		0.002409	51.2	3.3	75.46	61				-857	4.27
21	0.151	0.092	0.607	6.1	7224	250	0.058381	0.059195	0.000092	7325	0.059195
26	60.1	12.38	291.9	-1	-1212	24	0.009797	-0.0005	0.000009	291559	0.003504
	-10.01	14.775	672.5	2.6	-114	9538	-0.000918	-0.000918	-97.95	530	0.001181
		0.002406	51.9	3.8	74.71	62				-887	4.35

RUN POINT	V/OR VKTS ALFS,U	MTUN QPSF BARO RHO	MTIP RPM OMEG*R TTEMPF	THETA A1 B1 CONING	LIFTH,C DRAGH,C SIDEH,C SKANGLE	PITCHH,S ROLLH,S TORQ,C HFORCE	CLRH/S CXRH/S CYRH/S	CLRHS/S CXRHS/S CYRHS/S	CMYHS/S CMXHS/S FE	THRUST POW HP VD	CTH/S CP/S CPO/S L/DR
21	0.151	0.091	0.605	7.2	8617	388	0.070126	0.071094	0.000143	8736	0.071094
27	60.1	12.35	291	-1.4	-1439	-149	0.011708	-0.000659	-0.000055	350206	0.004251
	-10.01	14.775	670.4	2.9	-183	11492	-0.001491	-0.001491	-116.44	637	0.001264
		0.002404	52.3	4.4	73.74	81				-901	4.28
21	0.152	0.092	0.602	8.3	9624	239	0.079015	0.080148	0.000089	9762	0.080148
28	60.1	12.38	289.5	-1.7	-1637	-182	0.013441	-0.000498	-0.000068	402153	0.00495
	-10.01	14.774	667	3.3	-226	13265	-0.001856	-0.001856	-132.29	731	0.001371
		0.002407	51.5	4.9	73.07	61				-930	4.13
21	0.152	0.092	0.604	9.2	10766	287	0.087855	0.089108	0.000107	10920	0.089108
29	60.1	12.4	290.5	-1.9	-1826	-172	0.014901	-0.000597	-0.000064	462440	0.005638
	-10.01	14.774	669.3	3.5	-273	15201	-0.002232	-0.002232	-147.31	841	0.001475
		0.002405	51.9	5.4	72.32	73				-938	3.95
21	0.152	0.092	0.604	10.2	11797	301	0.096446	0.097821	0.000112	11965	0.097821
30	60.1	12.4	290.2	-2.2	-2001	-192	0.016358	-0.000655	-0.000072	521705	0.00638
	-10.01	14.774	668.6	3.8	-330	17167	-0.002697	-0.002697	-161.41	949	0.001605
		0.002406	51.8	5.8	71.64	80				-945	3.76
21	0.154	0.092	0.595	2.3	2564	31	0.021538	0.021766	0.000012	2591	0.021766
31	60.1	12.4	286.3	-0.3	-381	-7	0.003197	-0.000595	-0.000003	133728	0.001703
	-10.01	14.774	659.6	1.4	-31	4460	-0.00026	-0.00026	-30.7	243	0.001098
		0.002406	51.8	1.8	78.08	71				-549	2.74
22	0.151	0.092	0.607	2.3	2811	147	0.022741	0.023013	0.000054	2845	0.023013
12	60.4	12.35	293.3	-0.3	-439	-28	0.003553	-0.000446	-0.00001	145799	0.001746
	-9.99	14.761	675.7	1.4	-22	4747	-0.000174	-0.000174	-35.55	265	0.001082
		0.00238	56.7	1.8	77.9	55				-629	2.83

RUN POINT	V/OR VKTS ALFS,U	MTUN QPSF BARO RHO	MTIP RPM OMEG*R TTEMPF	THETA A1 B1 CONING	LIFTH,C DRAGH,C SIDEH,C SKANGLE	PITCHH,S ROLLH,S TORQ,C HFORCE	CLRH/S CXRH/S CYRH/S	CLRHS/S CXRHS/S CYRHS/S	CMYHS/S CMXHS/S FE	THRUST POW HP VD	CTH/S CP/S CPO/S L/DR
22	0.151	0.091	0.604	3	3664	302	0.029909	0.030279	0.000112	3709	0.030279
13	60.3	12.34	292	-0.5	-581	-17	0.004742	-0.000518	-0.000006	166470	0.00202
	-9.99	14.762	672.7	1.5	-31	5444	-0.00025	-0.00025	-47.06	303	0.001081
		0.00238	56.8	2.2	77.27	63				-717	3.48
22	0.151	0.092	0.607	4	4904	270	0.039674	0.040197	0.000099	4969	0.040197
14	60.4	12.37	293.3	-0.7	-801	-95	0.006481	-0.0005	-0.000035	206014	0.002466
	-9.99	14.762	675.7	1.8	-59	6707	-0.000479	-0.000479	-64.79	375	0.001098
		0.00238	56.7	2.7	76.38	62				-807	4.02
22	0.151	0.092	0.606	5	6022	260	0.048909	0.049579	0.000096	6105	0.049579
15	60.4	12.37	292.7	-1	-1002	-142	0.008137	-0.000471	-0.000053	244645	0.002946
	-9.99	14.762	674.3	2.2	-90	7982	-0.000734	-0.000734	-81.03	445	0.001125
		0.002381	56.6	3.2	75.58	58				-858	4.31
22	0.151	0.092	0.606	6.1	7287	332	0.059131	0.059949	0.000122	7388	0.059949
16	60.4	12.37	292.9	-1.2	-1218	-135	0.009883	-0.000525	-0.000005	294182	0.003537
	-9.99	14.761	674.8	2.6	-125	9591	-0.001014	-0.001014	-98.5	535	0.001179
		0.00238	56.8	3.8	74.69	65				-888	4.37
22	0.151	0.092	0.607	7	8391	275	0.067967	0.068933	0.000101	8510	0.068933
17	60.4	12.39	293.1	-1.3	-1421	-152	0.011513	-0.000452	-0.000056	342945	0.004114
	-9.99	14.761	675.3	2.9	-164	11173	-0.001331	-0.001331	-114.76	624	0.001231
		0.002381	56.6	4.2	73.93	56				-918	4.32
22	0.152	0.092	0.604	8.2	9677	323	0.079007	0.08013	0.00012	9815	0.08013
18	60.4	12.38	291.9	-1.7	-1639	-199	0.01338	-0.000529	-0.000074	404779	0.004914
	-9.99	14.76	672.5	3.3	-227	13242	-0.001849	-0.001849	-132.43	736	0.001346
		0.002381	56.4	4.8	73.05	65				-931	4.15

RUN POINT	V/OR VKTS ALFS,U	MTUN QPSF BARO RHO	MTIP RPM OMEG*R TTEMPF	THETA A1 B1 CONING	LIFTH,C DRAGH,C SIDEH,C SKANGLE	PITCHH,S ROLLH,S TORQ,C HFORCE	CLRHS/S CXRHS/S CYRHS/S	CLRH/S CXRH/S CYRH/S	CMYHS/S CMXHS/S FE	THRUST POW HP VD	CTH/S CP/S CPO/S L/DR
22	0.151	0.092	0.605	9.2	10909	351	0.0889	0.090163	0.00013	11064	0.090163
19	60.4	12.38	292.2	-2	-1847	-277	0.015049	-0.000601	-0.000103	470973	0.005702
	-9.99	14.759	673.2	3.5	-296	15392	-0.002413	-0.002413	-149.22	856	0.001471
		0.002381	56.5	5.3	72.23	74				-941	3.93
22	0.152	0.092	0.605	10.3	12123	304	0.098936	0.100358	0.000113	12298	0.100358
20	60.4	12.38	292	-2.3	-2064	-192	0.016847	-0.000571	-0.000071	544495	0.006605
	-9.99	14.759	672.7	3.9	-341	17807	-0.00278	-0.00278	-166.82	990	0.001636
		0.002381	56.5	5.9	71.44	70				-955	3.7
22	0.151	0.092	0.606	11.5	13365	251	0.108656	0.110253	0.000093	13561	0.110253
21	60.4	12.39	292.5	-2.7	-2300	-236	0.018698	-0.000434	-0.000087	633937	0.007648
	-9.99	14.758	673.9	4.3	-421	20696	-0.003421	-0.003421	-185.69	1153	0.001901
		0.002381	56.3	6.4	70.65	53				-973	3.41
22	0.151	0.092	0.606	12.7	14484	398	0.117765	0.119478	0.000147	14694	0.119478
22	60.4	12.39	292.5	-3	-2480	-251	0.020166	-0.000569	-0.000093	735748	0.008878
	-9.99	14.76	673.9	4.6	-495	24020	-0.004022	-0.004022	-200.25	1338	0.002398
		0.002381	56.4	6.8	69.94	70				-973	3.06
24	0.151	0.091	0.605	2.3	4993	158	0.040738	0.04074	0.000059	4994	0.04074
7	60.2	12.23	292.6	-1.2	-91	-317	0.000744	-0.000671	-0.000118	133325	0.001614
	-1.99	14.722	674.1	1.5	-71	4351	-0.000582	-0.000582	-7.46	242	0.001089
		0.002372	57.1	2.8	84.2	82				68	4.09
24	0.15	0.091	0.606	4.3	7423	103	0.06046	0.060479	0.000038	7425	0.060479
8	60.1	12.21	292.9	-1.4	-193	-203	0.001574	-0.000527	-0.000075	188213	0.002272
	-1.99	14.722	674.8	2.5	-127	6136	-0.001036	-0.001036	-15.82	342	0.001126
		0.00237	57.3	3.9	82.37	65				-38	4.47

RUN POINT	V/OR VKTS ALFS,U	MTUN QPSF BARO RHO	MTIP RPM OMEG*R TTEMPF	THETA A1 B1 CONING	LIFTH,C DRAGH,C SIDEH,C SKANGLE	PITCHH,S ROLLH,S TORQ,C HFORCE	CLRHS/S CXRHS/S CYRHS/S	CLRHS/S CXRHS/S CYRHS/S	CMYHS/S CMXHS/S FE	THRUST POW HP VD	CTH/S CP/S CPO/S L/DR
24	0.15	0.091	0.607	6.4	9824	64	0.07972	0.079756	0.000023	9828	0.079756
9	60.2	12.23	293.3	-1.8	-301	-162	0.002441	-0.000328	-0.00006	266321	0.003198
	-1.99	14.72	675.7	3.3	-209	8671	-0.001699	-0.001699	-24.6	484	0.00125
		0.002373	56.7	5	80.62	40				-96	4.23
24	0.151	0.091	0.605	7.3	10980	363	0.089581	0.089614	0.000135	10984	0.089614
10	60.2	12.24	292.5	-2.1	-306	-316	0.002499	-0.000614	-0.000117	303611	0.003676
	-1.99	14.722	673.9	3.4	-298	9912	-0.002428	-0.002428	-25.02	552	0.001308
		0.002373	56.7	5.5	79.79	75				-88	4.09
24	0.151	0.091	0.605	8.5	12307	326	0.100388	0.10043	0.000121	12312	0.10043
11	60.2	12.25	292.5	-2.4	-364	-270	0.002965	-0.000522	-0.0001	363608	0.004401
	-1.99	14.722	673.9	3.9	-358	11871	-0.002921	-0.002921	-29.67	661	0.001454
		0.002374	56.6	6.1	78.85	64				-107	3.83
24	0.15	0.091	0.609	9.5	13592	329	0.109522	0.109572	0.000121	13599	0.109572
12	60.2	12.26	294.4	-2.6	-414	-162	0.003335	-0.00047	-0.000059	432263	0.005135
	-1.99	14.721	678.2	4.2	-406	14021	-0.003267	-0.003267	-33.76	786	0.001643
		0.002372	56.9	6.5	77.96	58				-120	3.54
24	0.151	0.091	0.605	10.7	14664	444	0.1197	0.119757	0.000165	14671	0.119757
13	60.3	12.29	292.5	-3	-459	-216	0.003745	-0.000414	-0.00008	505069	0.006118
	-1.99	14.721	673.9	4.6	-491	16489	-0.004011	-0.004011	-37.32	918	0.002005
		0.002372	56.9	7	77.25	51				-130	3.26
28	0.149	0.091	0.61	2.3	7288	158	0.058353	0.058629	0.000058	7323	0.058629
7	60.2	12.23	295.4	-1.3	714	-58	-0.00572	-0.000612	-0.000021	85400	0.001005
	5	14.761	680.6	1.7	-101	2761	-0.000808	-0.000808	58.4	155	0.001005
		0.002371	58.7	3.9	89.33	76				715	4.69

RUN POINT	V/OR VKTS ALFS,U	MTUN QPSF BARO RHO	MTIP RPM OMEG*R TTEMPF	THETA A1 B1 CONING	LIFTH,C DRAGH,C SIDEH,C SKANGLE	PITCHH,S ROLLH,S TORQ,C HFORCE	CLRH/S CXRH/S CYRH/S	CLRHS/S CXRHS/S CYRHS/S	CMYHS/S CMXHS/S FE	THRUST POW HP VD	CTH/S CP/S CPO/S L/DR
28	0.151	0.091	0.604	3.4	8549	197	0.069932	0.070249	0.000073	8588	0.070249
8	60.2	12.24	292.2	-1.6	818	-38	-0.006694	-0.000574	-0.000014	98942	0.001202
	5	14.761	673.2	2.1	-142	3233	-0.001165	-0.001165	66.85	180	0.001001
		0.002372	58.5	4.6	88.36	70				684	4.77
28	0.15	0.091	0.606	4.4	9850	317	0.079944	0.080313	0.000117	9895	0.080313
9	60.2	12.25	293.3	-1.8	951	-76	-0.00772	-0.000723	-0.000028	119835	0.001439
	5	14.761	675.7	2.3	-190	3902	-0.001542	-0.001542	77.64	218	0.001011
		0.002372	58.3	5.1	87.36	89				676	4.62
28	0.15	0.091	0.607	5.3	11022	279	0.089215	0.089612	0.000103	11071	0.089612
10	60.2	12.25	293.7	-2	1044	-150	-0.008453	-0.000645	-0.000055	146116	0.001748
	5	14.761	676.6	2.7	-250	4751	-0.002023	-0.002023	85.23	266	0.001036
		0.002372	58.3	5.7	86.46	80				655	4.44
28	0.151	0.091	0.605	6.5	12320	296	0.100526	0.100962	0.00011	12373	0.100962
11	60.2	12.26	292.5	-2.3	1152	-124	-0.009398	-0.0006	-0.000046	180393	0.002184
	5	14.761	673.9	3.2	-312	5889	-0.002544	-0.002544	93.92	328	0.001097
		0.002373	58.2	6.3	85.47	74				640	4.21
28	0.151	0.091	0.605	7.5	13408	358	0.109231	0.109708	0.000132	13466	0.109708
12	60.3	12.27	292.7	-2.5	1256	-103	-0.010235	-0.000676	-0.000038	215890	0.002608
	5	14.762	674.3	3.5	-366	7043	-0.002978	-0.002978	102.36	393	0.001193
		0.002373	58.1	6.8	84.66	83				635	3.97
28	0.151	0.091	0.604	8.5	14559	294	0.118817	0.119313	0.000109	14620	0.119313
13	60.2	12.26	292.5	-2.8	1333	-139	-0.010876	-0.000479	-0.000052	264189	0.0032
	5	14.763	673.9	3.8	-445	8625	-0.00363	-0.00363	108.67	480	0.001341
		0.002372	58.3	7.3	83.79	59				617	3.7

RUN POINT	V/OR VKTS ALFS,U	MTUN QPSF BARO RHO	MTIP RPM OMEG*R TTEMPF	THETA A1 B1 CONING	LIFTH,C DRAGH,C SIDEH,C SKANGLE	PITCHH,S ROLLH,S TORQ,C HFORCE	CLRHS/S CXRHS/S CXRHS/S	CLRH/S CXRH/S CXRHS/S	CMYHS/S CMXHS/S FE	THRUST POW HP VD	CTH/S CP/S CPO/S L/DR
28	0.151	0.091	0.606	7.6	13558	281	0.109997	0.110459	0.000104	13615	0.110459
14	60.3	12.27	293.3	-2.7	1245	-240	-0.010102	-0.000476	-0.000089	224270	0.002693
	5	14.764	675.7	3.6	-409	7302	-0.003322	-0.003322	101.45	408	0.001206
		0.002373	58.1	6.8	84.55	59				623	3.93
30	0.15	0.091	0.605	2.3	8469	180	0.069349	0.070559	0.000067	8616	0.070559
12	60	12.14	292.5	-1.6	1592	-65	-0.013034	-0.000782	-0.000024	24639	0.000299
	10.01	14.706	673.9	1.7	-172	804	-0.001409	-0.001409	131.12	45	0.001063
		0.002364	58.1	4.7	93.23	95				1222	4.62
30	0.15	0.091	0.606	3.2	9652	212	0.078772	0.080138	0.000079	9819	0.080138
13	60.1	12.15	293	-1.7	1808	-44	-0.014758	-0.000841	-0.000016	32132	0.000388
	10.01	14.706	675	2.1	-202	1047	-0.001646	-0.001646	148.84	58	0.00106
		0.002364	58.1	5.3	92.27	103				1207	4.54
30	0.15	0.091	0.605	4.1	10784	125	0.08825	0.089748	0.000047	10967	0.089748
14	60.1	12.16	292.6	-1.9	1997	-69	-0.016344	-0.000756	-0.000026	44306	0.000538
	10.01	14.706	674.1	2.3	-242	1446	-0.001977	-0.001977	164.24	81	0.001061
		0.002364	58.1	5.8	91.35	92				1186	4.43
30	0.151	0.091	0.604	5.1	11972	237	0.098125	0.099822	0.000088	12179	0.099822
15	60.1	12.16	292.3	-2	2240	-93	-0.018356	-0.001021	-0.000035	56212	0.000684
	10.01	14.707	673.4	2.4	-287	1836	-0.00235	-0.00235	184.17	102	0.001057
		0.002365	57.9	6.4	90.38	125				1189	4.28
30	0.15	0.091	0.606	6.1	13332	246	0.108831	0.110732	0.000091	13565	0.110732
16	60.1	12.16	292.8	-2.2	2507	-105	-0.020465	-0.001236	-0.000039	78974	0.000956
	10.01	14.708	674.6	2.7	-341	2576	-0.002783	-0.002783	206.17	144	0.001083
		0.002367	57.6	7	89.28	151				1187	4.06

RUN POINT	V/OR VKTS ALFS,U	MTUN QPSF BARO RHO	MTIP RPM OMEG*R TTEMPF	THETA A1 B1 CONING	LIFTH,C DRAGH,C SIDEH,C SKANGLE	PITCHH,S ROLLH,S TORQ,C HFORCE	CLRH/S CXRH/S CYRH/S	CLRHS/S CXRHS/S CYRHS/S	CMYHS/S CMXHS/S FE	THRUST POW HP VD	CTH/S CP/S CPO/S L/DR
30	0.15	0.091	0.606	7.1	14416	58	0.117396	0.119384	0.000021	14660	0.119384
17	59.9	12.11	293.1	-2.4	2667	-78	-0.021716	-0.00098	-0.000029	109456	0.00132
	10.01	14.711	675.3	3.1	-387	3566	-0.003151	-0.003151	220.23	199	0.001131
		0.002368	57.5	7.5	88.36	120				1162	3.85
22	0.201	0.121	0.604	2.2	1717	152	0.014084	0.01417	0.000056	1727	0.01417
23	80	21.66	291.5	-0.2	-211	-151	0.001727	-0.000742	-0.000056	127389	0.001556
	-9.99	14.76	671.6	1.4	-16	4173	-0.000129	-0.000129	-9.72	232	0.001172
		0.002376	56.1	1.3	79.27	91				233	2.34
22	0.2	0.121	0.606	3.7	3633	23	0.029578	0.029925	0.000009	3676	0.029925
24	80	21.67	292.6	-0.3	-564	-58	0.004589	-0.000612	-0.000021	185754	0.002243
	-9.99	14.76	674.1	2.2	-33	6062	-0.000265	-0.000265	-26.01	338	0.001161
		0.002377	56.1	2.2	78.45	75				-675	4.48
22	0.201	0.122	0.605	4.7	4772	93	0.038981	0.039479	0.000034	4833	0.039479
25	80.1	21.71	292.1	-0.5	-768	-121	0.006275	-0.000582	-0.000045	223753	0.002716
	-9.99	14.762	673	2.6	-57	7315	-0.000463	-0.000463	-35.4	407	0.001173
		0.002377	56.1	2.7	77.97	71				-858	5.38
22	0.201	0.122	0.605	5.7	6066	122	0.049665	0.050337	0.000045	6148	0.050337
26	80.1	21.74	291.7	-0.7	-1003	-114	0.008212	-0.000528	-0.000042	272976	0.003326
	-9.99	14.762	672	3.2	-84	8936	-0.000685	-0.000685	-46.15	496	0.001215
		0.002378	55.9	3.3	77.43	64				-985	5.97
22	0.201	0.122	0.606	6.7	7229	171	0.058867	0.059689	0.000063	7330	0.059689
27	80.1	21.74	292.5	-1	-1214	-269	0.009882	-0.00048	-0.0001	323537	0.00391
	-9.99	14.761	673.9	3.6	-134	10563	-0.001089	-0.001089	-55.83	588	0.001281
		0.002378	55.9	3.8	76.95	59				-1060	6.13

RUN POINT	V/OR VKTS ALFS,U	MTUN QPSF BARO RHO	MTIP RPM OMEG*R TTEMPF	THETA A1 B1 CONING	LIFTH,C DRAGH,C SIDEH,C SKANGLE	PITCHH,S ROLLH,S TORQ,C HFORCE	CLRHS/S CXRHS/S CYRHS/S	CLRH/S CXRH/S CYRH/S	CMYHS/S CMXHS/S FE	THRUST POW HP VD	CTH/S CP/S CPO/S L/DR
23	0.2	0.121	0.606	2.2	1786	250	0.014629	0.014705	0.000093	1796	0.014705
5	79.9	21.43	293.1	-0.3	-210	-245	0.00172	-0.000846	-0.000091	129146	0.001566
	-10	14.719	675.3	1.3	-3	4208	-0.000022	-0.000022	-9.8	235	0.001182
		0.002355	59.1	1.3	79.23	103				213	2.39
23	0.2	0.121	0.606	3.6	3435	174	0.028089	0.028391	0.000065	3472	0.028391
6	80	21.46	293.3	-0.3	-513	-114	0.004196	-0.000745	-0.000042	178607	0.002161
	-10	14.719	675.7	2	-20	5815	-0.000163	-0.000163	-23.91	325	0.001175
		0.002355	59.1	2.1	78.51	91				-601	4.24
23	0.2	0.121	0.606	5.8	6103	170	0.04991	0.050584	0.000063	6185	0.050584
7	80.1	21.49	293.4	-0.8	-1009	-165	0.008251	-0.000541	-0.000061	276826	0.003349
	-10	14.72	675.9	3.2	-82	9010	-0.00067	-0.00067	-46.95	503	0.001233
		0.002353	59.5	3.2	77.38	66				-991	5.87
23	0.2	0.121	0.606	7.8	8482	209	0.069274	0.07028	0.000077	8605	0.07028
8	80.1	21.5	293.6	-1.3	-1451	-128	0.011855	-0.000354	-0.000047	385302	0.004652
	-10	14.719	676.4	4.2	-155	12532	-0.00127	-0.00127	-67.51	701	0.001385
		0.002353	59.5	4.2	76.38	43				-1130	6.06
23	0.2	0.121	0.606	9.9	10859	163	0.088867	0.090233	0.000061	11026	0.090233
9	80.1	21.51	293.4	-1.9	-1912	-182	0.015645	-0.000025	-0.000068	517126	0.006261
	-10	14.719	675.9	5.1	-269	16831	-0.002199	-0.002199	-88.87	940	0.001654
		0.002351	59.8	5.2	75.4	3				-1222	5.68
23	0.2	0.121	0.607	10.8	12163	610	0.099079	0.100477	0.000226	12335	0.100477
10	80.2	21.56	294	-1.9	-2052	46	0.016717	-0.000742	0.000017	583023	0.007012
	-10	14.719	677.3	5.1	-302	18937	-0.002459	-0.002459	-95.18	1060	0.001834
		0.002353	59.5	5.8	74.89	91				-1185	5.4

RUN POINT	V/OR VKTS ALFS,U	MTUN QPSF BARO RHO	MTIP RPM OMEG*R TTEMPF	THETA A1 B1 CONING	LIFTH,C DRAGH,C SIDEH,C SKANGLE	PITCHH,S ROLLH,S TORQ,C HFORCE	CLRH/S CXRH/S CYRH/S	CLRHS/S CXRHS/S CYRHS/S	CMYHS/S CMXHS/S FE	THRUST POW HP VD	CTH/S CP/S CPO/S L/DR
23	0.199	0.121	0.608	12	13350	402	0.10833	0.109954	0.000148	13550	0.109954
11	80.2	21.54	294.5	-2.5	-2320	-91	0.018827	-0.00027	-0.000034	676195	0.008087
	-10	14.719	678.5	5.7	-400	21926	-0.003247	-0.003247	-107.71	1229	0.002132
		0.002354	59.3	6.3	74.41	33				-1239	4.99
23	0.201	0.121	0.605	12.8	13881	204	0.114081	0.115883	0.000076	14100	0.115883
12	80.2	21.57	292.6	-3.1	-2477	-292	0.020357	0.000238	-0.000109	728853	0.008886
	-10	14.72	674.1	6.1	-488	23787	-0.004009	-0.004009	-114.83	1325	0.002374
		0.002354	59.2	6.5	74.2	-29				-1282	4.78
23	0.201	0.121	0.604	13.4	14412	461	0.118494	0.120308	0.000172	14633	0.120308
13	80.2	21.55	292.5	-3.1	-2531	-168	0.02081	-0.000082	-0.000063	785352	0.009582
	-10	14.721	673.9	6.3	-520	25640	-0.004279	-0.004279	-117.45	1428	0.002788
		0.002355	59.1	6.8	73.99	10				-1264	4.4
23	0.201	0.121	0.605	8.7	9547	282	0.078435	0.079573	0.000105	9685	0.079573
14	80.1	21.55	292.5	-1.4	-1633	-76	0.013417	-0.000435	-0.000028	437470	0.005334
	-10.02	14.724	673.9	4.4	-210	14282	-0.001724	-0.001724	-75.77	795	0.001495
		0.002356	58.9	4.8	75.93	53				-1156	5.96
25	0.2	0.121	0.607	2.3	4986	61	0.040786	0.040783	0.000023	4986	0.040783
5	79.8	21.49	292.4	-0.8	-77	-214	0.000631	-0.000793	-0.000079	130107	0.00158
	-2	14.645	673.6	2	-63	4249	-0.000515	-0.000515	-3.59	237	0.001143
		0.002368	53.7	2.8	85.82	97				293	5.61
25	0.2	0.121	0.606	3.1	5992	118	0.049284	0.049286	0.000044	5992	0.049286
6	79.8	21.47	291.6	-0.8	-112	-219	0.000918	-0.000803	-0.000082	146145	0.001789
	-2	14.646	671.8	2.4	-78	4786	-0.000641	-0.000641	-5.2	266	0.001152
		0.002369	53.7	3.2	85.39	98				197	6.15

RUN POINT	V/OR VKTS ALFS,U	MTUN QPSF BARO RHO	MTIP RPM OMEG*R TTEMPF	THETA A1 B1 CONING	LIFTH,C DRAGH,C SIDEH,C SKANGLE	PITCHH,S ROLLH,S TORQ,C HFORCE	CLRHS/S CXRHS/S CYRHS/S	CLRH/S CXRH/S CYRH/S	CMYHS/S CMXHS/S FE	THRUST POW HP VD	CTH/S CP/S CPO/S L/DR
25	0.201	0.121	0.604	4.1	7149	-97	0.059178	0.059193	-0.000037	7151	0.059193
7	79.8	21.5	290.6	-1	-176	-328	0.001456	-0.000611	-0.000123	170855	0.002112
	-2	14.647	669.5	3.2	-106	5614	-0.000881	-0.000881	-8.18	311	0.001169
		0.00237	53.5	3.8	84.89	74				93	6.54
25	0.2	0.121	0.606	5.2	8539	107	0.070145	0.070165	0.000004	8541	0.070165
8	79.8	21.47	291.7	-1.2	-216	-358	0.001775	-0.000674	-0.000134	202447	0.002475
	-2	14.648	672	3.6	-124	6627	-0.001019	-0.001019	-10.07	368	0.0012
		0.00237	53.5	4.4	84.28	82				39	6.63
25	0.201	0.121	0.605	6.2	9649	81	0.07962	0.079651	0.000003	9653	0.079651
9	79.8	21.49	291.1	-1.5	-274	-371	0.002262	-0.000518	-0.000139	234398	0.002884
	-2	14.649	670.6	4	-217	7689	-0.001792	-0.001792	-12.76	426	0.001249
		0.002369	53.7	4.9	83.81	63				-14	6.58
25	0.201	0.121	0.605	7.2	10994	108	0.090666	0.090703	0.000041	10998	0.090703
10	79.8	21.49	291.3	-1.6	-320	-222	0.002637	-0.000528	-0.000083	274974	0.003379
	-2	14.649	671.1	4.5	-268	9014	-0.002211	-0.002211	-14.88	500	0.001318
		0.002367	54.1	5.5	83.24	64				-46	6.39
25	0.201	0.121	0.604	8.4	12178	81	0.100567	0.100619	0.000003	12185	0.100619
11	79.9	21.5	291.1	-2	-393	-314	0.003247	-0.000264	-0.000118	325950	0.004013
	-2	14.65	670.6	5.1	-352	10693	-0.002906	-0.002906	-18.29	593	0.001479
		0.002367	54.1	6	82.74	32				-90	6.01
25	0.201	0.121	0.605	9.4	13359	242	0.109952	0.110008	0.000091	13366	0.110008
12	79.8	21.48	291.7	-2.3	-429	-314	0.003527	-0.000312	-0.000118	380329	0.004658
	-2	14.651	672	5.4	-437	12451	-0.003599	-0.003599	-19.95	692	0.001696
		0.002365	54.5	6.6	82.23	38				-103	5.58

RUN POINT	V/OR VKTS ALFS,U	MTUN QPSF BARO RHO	MTIP RPM OMEG*R TTEMPF	THETA A1 B1 CONING	LIFTH,C DRAGH,C SIDEH,C SKANGLE	PITCHH,S ROLLH,S TORQ,C HFORCE	CLRH/S CXRH/S CYRH/S	CLRHS/S CXRHS/S CYRHS/S	CMYHS/S CMXHS/S FE	THRUST POW HP VD	CTH/S CP/S CPO/S L/DR
25	0.201	0.122	0.605	10.4	14292	131	0.117688	0.11777	0.000049	14302	0.11777
13	79.9	21.52	291.7	-2.8	-533	-314	0.004388	0.000278	-0.000118	449887	0.005513
	-2	14.65	672	6.1	-510	14728	-0.004198	-0.004198	-24.76	818	0.002052
		0.002364	54.7	6.9	81.85	-34				-156	5.1
28	0.2	0.121	0.606	2.2	7721	194	0.062979	0.063276	0.000072	7757	0.063276
15	80	21.56	292.9	-1.1	755	-78	-0.006161	-0.000649	-0.000029	50198	0.000607
	5	14.764	674.8	2.4	-155	1637	-0.001262	-0.001262	35.03	91	0.001098
		0.002367	58.1	4.3	91.6	80				1055	6.85
28	0.2	0.121	0.605	2.9	8433	129	0.068933	0.069245	0.000048	8472	0.069245
16	80	21.58	292.6	-1.2	807	-80	-0.006593	-0.00056	-0.00003	55254	0.00067
	5	14.764	674.1	2.7	-180	1803	-0.001473	-0.001473	37.38	100	0.001104
		0.002367	58.1	4.6	91.29	69				1016	6.94
28	0.201	0.121	0.604	3.9	9730	235	0.07977	0.080135	0.000088	9775	0.080135
17	79.9	21.56	292.1	-1.3	935	-65	-0.007663	-0.000682	-0.000024	64268	0.000783
	5	14.765	673	3.1	-217	2101	-0.001776	-0.001776	43.35	117	0.001133
		0.002368	57.9	5.2	90.71	83				986	6.9
28	0.2	0.121	0.607	4.9	11045	266	0.089712	0.090119	0.000098	11095	0.090119
18	80	21.57	293.5	-1.5	1056	-97	-0.008581	-0.00073	-0.000036	80499	0.000967
	5	14.764	676.2	3.4	-266	2619	-0.002161	-0.002161	48.98	146	0.001172
		0.002367	58	5.8	90.13	90				958	6.68
28	0.2	0.121	0.605	5.9	12235	214	0.1001	0.100541	0.00008	12289	0.100541
19	80	21.58	292.5	-1.7	1153	-114	-0.009433	-0.000673	-0.000042	101346	0.00123
	5	14.764	673.9	4	-322	3309	-0.002631	-0.002631	53.42	184	0.001251
		0.002366	58.2	6.4	89.61	82				929	6.43

RUN POINT	V/OR VKTS ALFS,U	MTUN QPSF BARO RHO	MTIP RPM OMEG*R TTEMPF	THETA A1 B1 CONING	LIFTH,C DRAGH,C SIDEH,C SKANGLE	PITCHH,S ROLLH,S TORQ,C HFORCE	CLRH/S CXRH/S CYRH/S	CLRHS/S CXRHS/S CYRHS/S	CMYHS/S CMXHS/S FE	THRUST POW HP VD	CTH/S CP/S CPO/S L/DR
28	0.2	0.121	0.607	6.9	13497	135	0.109539	0.110004	0.00005	13554	0.110004
20	80	21.58	293.7	-1.9	1247	-186	-0.010117	-0.000531	-0.000069	132898	0.001594
	5	14.765	676.6	4.4	-399	4321	-0.003242	-0.003242	57.76	242	0.001365
		0.002366	58.3	6.9	89.05	65				898	6.05
28	0.201	0.121	0.604	8	14598	156	0.119652	0.120153	0.000058	14659	0.120153
21	80	21.57	292.3	-2.2	1339	-193	-0.010976	-0.000506	-0.000072	164528	0.002003
	5	14.766	673.4	4.8	-463	5375	-0.003797	-0.003797	62.08	299	0.001534
		0.002365	58.5	7.4	88.56	62				882	5.71
30	0.2	0.121	0.606	2.2	9428	82	0.077058	0.078438	0.000031	9597	0.078438
18	80.1	21.58	293	-1.3	1797	-54	-0.014684	-0.001067	-0.00002	-45291	-0.000548
	10.01	14.713	675	2.6	-240	-1476	-0.001958	-0.001958	83.24	-82	0.001285
		0.002361	57.7	5.3	95.8	130				1728	6.45
30	0.2	0.121	0.606	2.3	9422	103	0.076983	0.078359	0.000038	9591	0.078359
19	80.1	21.58	293	-1.3	1794	-47	-0.014657	-0.001053	-0.000017	-45254	-0.000548
	10.01	14.713	675	2.6	-239	-1475	-0.001952	-0.001952	83.12	-82	0.001281
		0.002362	57.5	5.3	95.8	129				1727	6.46
30	0.2	0.121	0.606	3.4	10815	102	0.088538	0.090082	0.000038	11004	0.090082
20	80.1	21.58	292.7	-1.4	2032	-24	-0.016635	-0.000992	-0.000009	-44989	-0.000546
	10.01	14.714	674.3	3.1	-279	-1468	-0.002283	-0.002283	94.15	-82	0.001326
		0.002362	57.5	5.9	95.17	121				1681	6.36
30	0.201	0.121	0.605	4.4	12024	156	0.098537	0.100239	0.000058	12232	0.100239
21	80.1	21.6	292.6	-1.6	2248	-101	-0.018423	-0.001015	-0.000038	-41765	-0.000508
	10.01	14.715	674.1	3.5	-334	-1363	-0.002739	-0.002739	104.06	-76	0.00138
		0.002361	57.7	6.5	94.62	124				1657	6.2

RUN POINT	V/OR VKTS ALFS,U	MTUN QPSF BARO RHO	MTIP RPM OMEG*R TTEMPF	THETA A1 B1 CONING	LIFTH,C DRAGH,C SIDEH,C SKANGLE	PITCHH,S ROLLH,S TORQ,C HFORCE	CLRH/S CXRH/S CYRH/S	CLRHS/S CXRHS/S CYRHS/S	CMYHS/S CMXHS/S FE	THRUST POW HP VD	CTH/S CP/S CPO/S L/DR
30	0.201	0.121	0.606	5.6	13307	88	0.108966	0.110792	0.000033	13530	0.110792
22	80.1	21.58	292.7	-1.8	2448	-36	-0.020049	-0.000804	-0.000013	-27403	-0.000333
	10.01	14.716	674.3	4	-368	-894	-0.003014	-0.003014	113.45	-50	0.001472
		0.002361	57.7	7.1	94.03	98				1617	5.93
30	0.201	0.121	0.604	6.6	14495	65	0.119282	0.121245	0.000024	14733	0.121245
23	80.1	21.59	291.9	-1.9	2642	-166	-0.02174	-0.000675	-0.000062	-8516	-0.000104
	10.01	14.717	672.5	4.4	-454	-279	-0.003732	-0.003732	122.34	-15	0.00162
		0.002362	57.5	7.8	93.49	82				1592	5.62
63	0.251	0.152	0.606	6.8	3702	181	0.030253	0.031099	0.000067	3806	0.031099
28	100.3	33.87	292.7	-0.3	-888	-309	0.007253	-0.000824	-0.000115	274674	0.003329
	-15	14.803	674.3	3.5	-4	8961	-0.000036	-0.000036	-26.21	499	0.001372
		0.002366	58.3	-0.2	73.99	101				-1308	5.03
63	0.252	0.152	0.604	7.7	4826	264	0.039711	0.040903	0.000099	4971	0.040903
29	100.4	33.95	291.7	-0.3	-1195	-218	0.009832	-0.000781	-0.000081	338681	0.004147
	-15	14.802	672	4	-16	11087	-0.000132	-0.000132	-35.19	616	0.001434
		0.002366	58.3	0.3	73.68	95				-1637	6
63	0.251	0.152	0.605	8.8	5984	-4	0.049002	0.050608	-0.000002	6180	0.050608
30	100.2	33.84	292.4	-0.5	-1546	-121	0.012658	-0.000456	-0.000045	416830	0.005067
	-15	14.803	673.6	4.8	-30	13613	-0.000242	-0.000242	-45.68	758	0.001531
		0.002366	58.3	0.8	73.36	56				-1899	6.51
63	0.251	0.152	0.604	9.8	7186	102	0.059062	0.061048	0.000038	7428	0.061048
31	100.2	33.82	291.8	-0.9	-1880	-227	0.015449	-0.000363	-0.000085	494426	0.006045
	-15	14.803	672.3	5.2	-73	16180	-0.000602	-0.000602	-55.58	899	0.001641
		0.002367	58.1	1.3	73.04	44				-2038	6.88

RUN POINT	V/OR VKTS ALFS,U	MTUN QPSF BARO RHO	MTIP RPM OMEG*R TTEMPF	THETA A1 B1 CONING	LIFTH,C DRAGH,C SIDEH,C SKANGLE	PITCHH,S ROLLH,S TORQ,C HFORCE	CLRH/S CXRH/S CYRH/S	CLRHS/S CXRHS/S CYRHS/S	CMYHS/S CMXHS/S FE	THRUST POW HP VD	CTH/S CP/S CPO/S L/DR
63	0.252	0.152	0.604	9.8	7192	111	0.059156	0.061144	0.000042	7434	0.061144
32	100.2	33.87	291.7	-0.9	-1881	-222	0.01547	-0.000367	-0.000083	494073	0.006047
	-15	14.802	672	5.2	-74	16174	-0.000613	-0.000613	-55.53	898	0.001633
		0.002367	58.1	1.3	73.04	45				-2039	6.92
63	0.251	0.152	0.605	10.9	8536	224	0.069905	0.072299	0.000083	8828	0.072299
33	100.2	33.84	292.3	-1.3	-2253	-239	0.018454	-0.000268	-0.000089	588202	0.007153
	-15	14.805	673.4	5.7	-119	19216	-0.000973	-0.000973	-66.58	1069	0.001792
		0.002367	58.1	1.8	72.68	33				-2146	6.97
63	0.251	0.152	0.606	11.8	9567	213	0.078063	0.080806	0.000079	9904	0.080806
34	100.3	33.92	292.8	-1.7	-2558	-369	0.020874	-0.000041	-0.000137	670669	0.008112
	-15	14.804	674.6	6.1	-181	21873	-0.001478	-0.001478	-75.42	1219	0.001966
		0.002368	57.9	2.3	72.41	5				-2228	6.81
63	0.251	0.152	0.606	12.9	10665	197	0.087075	0.090196	0.000073	11047	0.090196
35	100.3	33.96	292.7	-2.1	-2881	-278	0.023523	0.000185	-0.000103	762218	0.009229
	-15	14.805	674.3	6.6	-215	24867	-0.001757	-0.001757	-84.83	1386	0.002192
		0.002368	57.9	2.7	72.13	-23				-2296	6.59
23	0.249	0.151	0.607	4.6	3663	207	0.030004	0.03031	0.000077	3700	0.03031
15	99.9	33.37	293.5	-0.2	-535	18	0.004386	-0.000896	0.000007	207199	0.00251
	-10.01	14.725	676.2	2.9	-36	6741	-0.000291	-0.000291	-16.04	377	0.001282
		0.002347	59.2	2.2	78.97	109				-372	5.28
23	0.249	0.151	0.609	5.4	4503	-12	0.036687	0.037123	-0.000004	4556	0.037123
16	99.9	33.38	294.3	-0.3	-702	-16	0.005722	-0.000742	-0.000006	244617	0.00294
	-10.01	14.724	678	3.5	-51	7937	-0.000414	-0.000414	-21.04	445	0.001314
		0.002347	59.2	2.5	78.73	91				-676	6.02

RUN POINT	V/OR VKTS ALFS,U	MTUN QPSF BARO RHO	MTIP RPM OMEG*R TTEMPF	THETA A1 B1 CONING	LIFTH,C DRAGH,C SIDEH,C SKANGLE	PITCHH,S ROLLH,S TORQ,C HFORCE	CLRH/S CXRH/S CYRH/S	CLRHS/S CXRHS/S CYRHS/S	CMYHS/S CMXHS/S FE	THRUST POW HP VD	CTH/S CP/S CPO/S L/DR
23	0.251	0.151	0.604	6.7	6018	60	0.049715	0.050367	0.000023	6097	0.050367
17	99.9	33.39	292.3	-0.5	-981	-33	0.008104	-0.000661	-0.000012	309097	0.003792
	-10.01	14.724	673.4	4.2	-83	10098	-0.000684	-0.000684	-29.38	562	0.001393
		0.002347	59.3	3.2	78.31	80				-971	7.07
23	0.25	0.151	0.606	7.7	7236	14	0.059447	0.060275	0.000005	7336	0.060275
18	99.9	33.41	293	-0.8	-1213	-77	0.009969	-0.000516	-0.000029	370259	0.004507
	-10.01	14.723	675	4.8	-118	12067	-0.000967	-0.000967	-36.31	673	0.001487
		0.002349	58.9	3.7	77.98	63				-1129	7.37
23	0.251	0.151	0.603	8.6	8146	19	0.067668	0.068641	0.000007	8263	0.068641
19	100	33.43	291.4	-1	-1387	-56	0.01152	-0.000417	-0.000021	416746	0.005157
	-10.01	14.722	671.3	5.4	-145	13657	-0.001202	-0.001202	-41.48	758	0.00158
		0.002348	58.9	4.1	77.73	50				-1216	7.52
23	0.248	0.152	0.61	9.8	9631	124	0.078065	0.079208	0.000046	9772	0.079208
20	100	33.44	295	-1.5	-1655	-223	0.013411	-0.000362	-0.000082	503167	0.006001
	-10.01	14.722	679.6	5.8	-223	16288	-0.00181	-0.00181	-49.47	915	0.001753
		0.002348	58.9	4.7	77.33	45				-1307	7.26
23	0.25	0.152	0.606	10.9	10870	123	0.089243	0.090581	0.000046	11033	0.090581
21	100	33.44	293.1	-1.8	-1890	-187	0.015514	-0.000235	-0.000007	576949	0.007015
	-10.01	14.723	675.3	6.3	-274	18797	-0.002251	-0.002251	-56.5	1049	0.001946
		0.002349	58.9	5.2	76.99	29				-1374	7.11
23	0.25	0.151	0.605	12	12002	91	0.099024	0.100551	0.000034	12187	0.100551
22	100	33.42	292.4	-2.2	-2116	-267	0.01746	-0.000018	-0.00001	657111	0.008048
	-10.01	14.721	673.6	6.9	-353	21460	-0.002914	-0.002914	-63.31	1195	0.002211
		0.002348	58.9	5.7	76.69	2				-1432	6.75

RUN POINT	V/OR VKTS ALFS,U	MTUN QPSF BARO RHO	MTIP RPM OMEG*R TTEMPF	THETA A1 B1 CONING	LIFTH,C DRAGH,C SIDEH,C SKANGLE	PITCHH,S ROLLH,S TORQ,C HFORCE	CLRH/S CXRH/S CYRH/S	CLRHS/S CXRHS/S CYRHS/S	CMYHS/S CMXHS/S FE	THRUST POW HP VD	CTH/S CP/S CPO/S L/DR
23	0.251	0.152	0.604	13.2	12997	89	0.10748	0.109185	0.000034	13203	0.109185
23	100.1	33.5	292	-2.8	-2324	-246	0.019221	0.000246	-0.000092	746626	0.009178
	-10.01	14.722	672.7	7.5	-420	24417	-0.003474	-0.003474	-69.37	1358	0.002632
		0.002349	58.7	6.2	76.43	-30				-1483	6.2
23	0.25	0.152	0.607	14.5	13967	278	0.114301	0.11616	0.000103	14194	0.11616
24	100	33.46	293.5	-3.6	-2530	-203	0.020706	0.000523	-0.000075	891517	0.01079
	-10.01	14.724	676.2	8.2	-522	29006	-0.004274	-0.004274	-75.61	1621	0.003664
		0.00235	58.7	6.5	76.16	-64				-1526	5.07
25	0.25	0.152	0.607	2.2	4590	107	0.037793	0.037787	0.00004	4590	0.037787
14	99.8	33.45	292.1	-0.4	-60	-76	0.00049	-0.000829	-0.000029	124989	0.001529
	-2	14.65	673	2.5	-75	4086	-0.000617	-0.000617	-1.78	227	0.001193
		0.002358	54.3	2.7	86.71	101				751	6.73
25	0.252	0.152	0.604	3.5	6089	47	0.050658	0.050663	0.000018	6089	0.050663
15	99.7	33.43	290.5	-0.5	-125	-19	0.00104	-0.000728	-0.000007	150233	0.001868
	-2	14.651	669.3	3.4	-104	4938	-0.000869	-0.000869	-3.74	273	0.001224
		0.002359	54.1	3.4	86.29	88				458	7.94
25	0.251	0.152	0.605	4.5	7325	85	0.060608	0.060621	0.000032	7326	0.060621
16	99.8	33.45	291.3	-0.7	-172	-71	0.001427	-0.000689	-0.000027	175301	0.002161
	-2	14.651	671.1	3.9	-146	5747	-0.00121	-0.00121	-5.16	319	0.001256
		0.002359	54.1	3.9	85.95	83				316	8.43
25	0.252	0.152	0.603	5.5	8393	39	0.069951	0.069973	0.000015	8396	0.069973
17	99.8	33.43	290.5	-0.9	-222	-96	0.001853	-0.000589	-0.000036	200640	0.002498
	-2	14.651	669.3	4.5	-188	6595	-0.00157	-0.00157	-6.65	365	0.001305
		0.002355	54.9	4.4	85.65	71				215	8.67

RUN POINT	V/OR VKTS ALFS,U	MTUN QPSF BARO RHO	MTIP RPM OMEG*R TTEMPF	THETA A1 B1 CONING	LIFTH,C DRAGH,C SIDEH,C SKANGLE	PITCHH,S ROLLH,S TORQ,C HFORCE	CLRH/S CXRH/S CYRH/S	CLRHS/S CXRHS/S CYRHS/S	CMYHS/S CMXHS/S FE	THRUST POW HP VD	CTH/S CP/S CPO/S L/DR
25	0.251	0.152	0.605	6.6	9670	133	0.080127	0.080155	0.00005	9674	0.080155
18	99.8	33.4	291.4	-1.3	-264	-209	0.002184	-0.000614	-0.000079	235662	0.002909
	-2	14.651	671.3	5	-260	7723	-0.002156	-0.002156	-7.89	428	0.001404
		0.002354	55.1	5	85.29	74				143	8.52
25	0.25	0.152	0.607	7.7	10854	27	0.089435	0.089475	0.00001	10859	0.089475
19	99.9	33.46	292.1	-1.4	-331	-78	0.002725	-0.000398	-0.000029	278318	0.003408
	-2	14.65	673	5.7	-297	9099	-0.002444	-0.002444	-9.88	506	0.001531
		0.002356	54.7	5.5	84.96	48				66	8.22
25	0.251	0.152	0.604	8.7	12071	112	0.100333	0.100379	0.000042	12076	0.100379
20	99.8	33.43	290.8	-1.7	-371	-219	0.003081	-0.000423	-0.000083	322283	0.003999
	-2	14.65	670	6.2	-387	10583	-0.003215	-0.003215	-11.09	586	0.001727
		0.002357	54.6	6.1	84.62	51				26	7.82
25	0.251	0.152	0.604	9.2	12622	96	0.104786	0.104838	0.000036	12628	0.104838
21	99.8	33.4	291	-1.7	-401	-97	0.003329	-0.00033	-0.000037	347245	0.0043
	-2	14.65	670.4	6.5	-398	11395	-0.003302	-0.003302	-12.01	631	0.001829
		0.002356	54.7	6.3	84.47	40				0	7.6
29	0.25	0.151	0.606	2.8	8506	85	0.069732	0.070069	0.000032	8547	0.070069
13	99.5	33.45	291.9	-0.9	843	-33	-0.006912	-0.000809	-0.000012	23684	0.000289
	5	14.761	672.5	3.5	-223	775	-0.001832	-0.001832	25.2	43	0.001287
		0.002371	55.5	4.7	92.59	99				1459	8.64
29	0.25	0.152	0.605	3.8	9679	220	0.079488	0.079867	0.000082	9726	0.079867
14	99.7	33.56	291.6	-1	953	-35	-0.007827	-0.00087	-0.000013	26962	0.00033
	5	14.761	671.8	3.9	-265	883	-0.002178	-0.002178	28.4	49	0.001345
		0.002372	55.3	5.3	92.26	106				1400	8.69

RUN POINT	V/OR VKTS ALFS,U	MTUN QPSF BARO RHO	MTIP RPM OMEG*R TTEMPF	THETA A1 B1 CONING	LIFTH,C DRAGH,C SIDEH,C SKANGLE	PITCHH,S ROLLH,S TORQ,C HFORCE	CLRH/S CXRH/S CYRH/S	CLRHS/S CXRHS/S CYRHS/S	CMYHS/S CMXHS/S FE	THRUST POW HP VD	CTH/S CP/S CPO/S L/DR
29	0.25	0.151	0.607	4.8	11018	238	0.090101	0.090516	0.000088	11069	0.090516
15	99.7	33.53	292.4	-1.1	1063	45	-0.008692	-0.000806	0.000017	37791	0.000459
	5	14.761	673.6	4.5	-299	1234	-0.002444	-0.002444	31.71	69	0.001414
		0.002369	55.9	5.9	91.88	99				1331	8.56
29	0.25	0.152	0.606	5.8	12131	196	0.099437	0.099872	0.000073	12184	0.099872
16	99.7	33.55	292	-1.3	1138	-7	-0.009327	-0.000625	-0.000002	55176	0.000672
	5	14.76	672.7	5.1	-360	1804	-0.002955	-0.002955	33.92	100	0.001526
		0.00237	55.7	6.4	91.57	76				1272	8.28
29	0.25	0.152	0.606	6.9	13481	266	0.110284	0.110759	0.000099	13539	0.110759
17	99.7	33.57	292.3	-1.5	1254	-126	-0.01026	-0.000609	-0.000047	80084	0.000973
	5	14.759	673.4	5.6	-458	2616	-0.003746	-0.003746	37.36	146	0.001717
		0.00237	55.7	7	91.18	74				1232	7.79
29	0.251	0.152	0.604	8.1	14460	206	0.119457	0.119931	0.000077	14517	0.119931
18	99.7	33.57	290.8	-1.8	1290	10	-0.010657	-0.000205	0.000004	121183	0.001494
	5	14.754	670	6.4	-498	3979	-0.004113	-0.004113	38.43	220	0.002046
		0.002371	55.3	7.5	90.91	25				1174	7.19
29	0.251	0.152	0.604	8.1	14472	197	0.119557	0.120031	0.000074	14529	0.120031
19	99.7	33.57	290.8	-1.8	1291	17	-0.010668	-0.000207	0.000006	120893	0.001491
	5	14.754	670	6.4	-501	3970	-0.004136	-0.004136	38.47	220	0.002042
		0.002371	55.3	7.5	90.9	25				1174	7.2
31	0.251	0.152	0.605	2.2	9904	186	0.081659	0.083113	0.000007	10081	0.083113
11	99.9	33.51	291.9	-0.8	1882	-49	-0.015514	-0.001084	-0.000018	-110320	-0.001353
	10.01	14.715	672.5	3.4	-281	-3609	-0.002317	-0.002317	56.14	-201	0.001542
		0.002358	56.6	5.6	97.18	131				2273	8.07

RUN POINT	V/OR VKTS ALFS,U	MTUN QPSF BARO RHO	MTIP RPM OMEG*R TTEMPF	THETA A1 B1 CONING	LIFTH,C DRAGH,C SIDEH,C SKANGLE	PITCHH,S ROLLH,S TORQ,C HFORCE	CLRH/S CXRH/S CYRH/S	CLRHS/S CXRHS/S CYRHS/S	CMYHS/S CMXHS/S FE	THRUST POW HP VD	CTH/S CP/S CPO/S L/DR
31	0.251	0.152	0.605	2.9	10766	234	0.088683	0.090232	0.000088	10954	0.090232
12	99.9	33.56	292	-0.9	2024	-132	-0.016676	-0.001007	-0.000049	-114800	-0.001406
	10.01	14.715	672.7	3.8	-329	-3754	-0.002712	-0.002712	60.33	-209	0.001603
		0.002358	56.5	6	96.93	122				2226	8.01
31	0.25	0.152	0.607	4	11994	298	0.098419	0.10009	0.000111	12198	0.10009
13	100	33.56	292.7	-1	2222	-90	-0.018231	-0.000847	-0.000034	-117886	-0.001434
	10.01	14.715	674.3	4.4	-372	-3846	-0.003051	-0.003051	66.21	-214	0.001681
		0.002356	56.9	6.6	96.58	103				2164	7.87
31	0.251	0.152	0.605	5.1	13149	301	0.108491	0.11028	0.000113	13366	0.11028
14	99.9	33.6	291.6	-1.2	2399	-184	-0.019794	-0.000635	-0.000069	-108389	-0.001331
	10.01	14.715	671.8	5	-436	-3550	-0.003601	-0.003601	71.41	-197	0.001886
		0.002361	55.9	7.2	96.25	77				2110	7.49
31	0.251	0.152	0.606	6.3	14415	275	0.118523	0.120413	0.000103	14645	0.120413
15	100	33.63	292	-1.2	2585	-109	-0.02125	-0.000325	-0.000041	-89348	-0.001092
	10.01	14.716	672.7	5.7	-473	-2922	-0.003887	-0.003887	76.86	-162	0.002142
		0.002363	55.6	7.8	95.88	40				2055	7.01
31	0.252	0.152	0.604	2.2	9848	46	0.081464	0.082877	0.000017	10019	0.082877
16	100.1	33.64	291.5	-0.9	1845	-54	-0.015263	-0.000871	-0.00002	-107625	-0.001326
	10.01	14.716	671.6	3.6	-303	-3526	-0.002508	-0.002508	54.85	-196	0.001528
		0.002357	56.9	5.6	97.2	105				2257	8.15

RUN POINT	V/OR VKTS ALFS,U	MTUN QPSF BARO RHO	MTIP RPM OMEG*R TTEMPF	THETA A1 B1 CONING	LIFTH,C DRAGH,C SIDEH,C SKANGLE	PITCHH,S ROLLH,S TORQ,C HFORCE	CLRH/S CXRH/S CYRH/S	CLRHS/S CXRHS/S CYRHS/S	CMYHS/S CMXHS/S FE	THRUST POW HP VD	CTH/S CP/S CPO/S L/DR
36	0.228	0.138	0.606	7.8	7850	251	0.064532	0.065467	0.000094	7964	0.065467
6	91.7	27.86	294.3	-0.9	-1341	-185	0.011028	-0.000346	-0.000069	379293	0.004599
	-10	14.681	678	4.6	-125	12307	-0.001024	-0.001024	-48.14	690	0.001399
		0.002326	62.7	4	77.4	42				-1182	7.08
36	0.251	0.152	0.605	8.3	7846	316	0.064967	0.065892	0.000119	7958	0.065892
7	100.6	33.48	293.4	-0.9	-1330	-119	0.01101	-0.000439	-0.000045	398693	0.004884
	-10	14.682	675.9	5.1	-118	12976	-0.00098	-0.00098	-39.71	725	0.00149
		0.002324	62.4	4	77.83	53				-1196	7.7
36	0.227	0.138	0.606	7.8	7824	232	0.064376	0.065317	0.000087	7939	0.065317
8	91.3	27.64	294.1	-1.1	-1344	-200	0.011055	-0.000292	-0.000075	378526	0.004596
	-10	14.683	677.6	4.6	-137	12291	-0.001123	-0.001123	-48.61	688	0.001401
		0.002328	62.5	4	77.38	35				-1186	7.03
36	0.201	0.121	0.604	7.3	7767	249	0.064181	0.065121	0.000094	7881	0.065121
9	80.2	21.39	293.2	-1.1	-1334	-142	0.011025	-0.000288	-0.000053	351720	0.004303
	-10	14.683	675.5	4	-139	11455	-0.001152	-0.001152	-62.38	639	0.001324
		0.002332	62.5	4	76.66	35				-1117	6.15
36	0.178	0.107	0.604	7	7803	206	0.064236	0.065184	0.000077	7918	0.065184
10	71.1	16.84	293.4	-1.2	-1346	-103	0.01108	-0.000243	-0.000039	337593	0.004112
	-10	14.686	675.9	3.5	-148	10988	-0.001222	-0.001222	-79.92	614	0.001275
		0.002337	62.1	4	75.77	29				-1045	5.32
36	0.151	0.091	0.605	6.7	7787	285	0.063934	0.064857	0.000106	7899	0.064857
11	60.4	12.15	293.6	-1.4	-1328	-126	0.010908	-0.00036	-0.000047	320570	0.003891
	-10	14.685	676.4	2.9	-163	10426	-0.001336	-0.001336	-109.34	583	0.001233
		0.00234	62.1	4	74.23	44				-918	4.28

RUN POINT	V/OR VKTS ALFS,U	MTUN QPSF BARO RHO	MTIP RPM OMEG*R TTEMPF	THETA A1 B1 CONING	LIFTH,C DRAGH,C SIDEH,C SKANGLE	PITCHH,S ROLLH,S TORQ,C HFORCE	CLRH/S CXRH/S CYRH/S	CLRHS/S CXRHS/S CYRHS/S	CMYHS/S CMXHS/S FE	THRUST POW HP VD	CTH/S CP/S CPO/S L/DR
36	0.15	0.091	0.605	6.7	7848	351	0.064233	0.06513	0.000131	7957	0.06513
22	60.3	12.12	293.9	-1.2	-1318	-92	0.010787	-0.000531	-0.000034	321670	0.003888
	-10	14.693	677.1	2.8	-159	10452	-0.0013	-0.0013	-108.75	585	0.001241
		0.002343	61.9	4.1	74.18	65				-902	4.25
36	0.124	0.075	0.606	6.6	7885	304	0.064362	0.065259	0.000113	7995	0.065259
23	50	8.34	294.1	-1.5	-1323	-53	0.010798	-0.000542	-0.00002	315690	0.003803
	-10	14.694	677.6	2.4	-168	10250	-0.001368	-0.001368	-158.56	574	0.001214
		0.002346	61.8	4.1	71.71	66				-775	3.26
36	0.101	0.061	0.605	6.6	7838	238	0.063968	0.064861	0.000088	7947	0.064861
24	40.5	5.49	294	-1.7	-1316	-94	0.01074	-0.000531	-0.000035	312913	0.003771
	-10	14.694	677.3	2	-184	10164	-0.001502	-0.001502	-239.57	569	0.001171
		0.002348	61.8	4	68.01	65				-646	2.41
36	0.091	0.055	0.605	6.7	7897	230	0.064554	0.065454	0.000086	8007	0.065454
25	36.6	4.49	293.7	-1.8	-1325	-167	0.010831	-0.000543	-0.000062	316995	0.00383
	-10	14.694	676.6	1.8	-201	10307	-0.00164	-0.00164	-295.18	576	0.001134
		0.002349	61.7	4.1	65.68	66				-589	2.08
36	0.081	0.049	0.605	6.8	7854	217	0.064161	0.065056	0.00008	7964	0.065056
26	32.6	3.56	293.7	-2	-1318	-204	0.01077	-0.000535	-0.000076	318349	0.003843
	-10	14.694	676.6	1.6	-208	10351	-0.001701	-0.001701	-370.65	579	0.001074
		0.002351	61.5	4	62.8	66				-529	1.76
36	0.071	0.043	0.604	6.9	7814	267	0.063874	0.064757	0.000099	7922	0.064757
27	28.6	2.74	293.5	-2	-1305	-202	0.010669	-0.000584	-0.000075	321091	0.003882
	-10	14.695	676.2	1.4	-210	10447	-0.001714	-0.001714	-476.7	584	0.000982
		0.002352	61.3	4	59.15	72				-465	1.46

RUN POINT	V/OR VKTS ALFS,U	MTUN QPSF BARO RHO	MTIP RPM OMEG*R TTEMPF	THETA A1 B1 CONING	LIFTH,C DRAGH,C SIDEH,C SKANGLE	PITCHH,S ROLLH,S TORQ,C HFORCE	CLRH/S CXRH/S CYRH/S	CLRHS/S CXRHS/S CYRHS/S	CMYHS/S CMXHS/S FE	THRUST POW HP VD	CTH/S CP/S CPO/S L/DR
36	0.061	0.037	0.604	7.1	7804	297	0.06391	0.064791	0.000111	7912	0.064791
28	24.3	1.98	293.2	-2	-1303	-209	0.010666	-0.000594	-0.000078	326461	0.003958
	-10	14.696	675.5	1.2	-208	10633	-0.001706	-0.001706	-657.57	594	0.000795
		0.002353	61.3	4	54.07	72				-398	1.17
36	0.051	0.031	0.605	7.4	7902	253	0.064472	0.065376	0.000094	8012	0.065376
29	20.5	1.41	293.7	-1.9	-1329	-224	0.010847	-0.000513	-0.000083	340049	0.0041
	-10	14.697	676.6	1	-201	11056	-0.001643	-0.001643	-944.15	618	0.000505
		0.002354	61.3	4.1	48.17	63				-340	0.93
36	0.042	0.025	0.604	7.5	7832	230	0.063953	0.064864	0.000085	7944	0.064864
30	16.7	0.94	293.6	-1.7	-1327	-202	0.010838	-0.000432	-0.000075	343014	0.004141
	-10	14.697	676.4	0.9	-184	11156	-0.001505	-0.001505	-1412.12	624	0.000946
		0.002353	61.4	4	41.58	53				-281	0.72
36	0.031	0.019	0.605	7.8	7883	280	0.064273	0.065191	0.000104	7995	0.065191
31	12.3	0.51	293.8	-1.2	-1338	-173	0.010907	-0.00042	-0.000064	358658	0.00432
	-10	14.698	676.9	0.6	-150	11657	-0.001227	-0.001227	-2622.88	652	0.001101
		0.002354	61.5	4	32.15	51				-208	0.5
36	0.021	0.013	0.605	8	7848	244	0.063848	0.064771	0.00009	7961	0.064771
32	8.5	0.24	294.1	-0.7	-1340	-28	0.010902	-0.000351	-0.00001	382700	0.004595
	-10	14.699	677.6	0.4	-101	12426	-0.000822	-0.000822	-5583.6	696	0.001407
		0.002354	61.5	4	22.91	43				-144	0.31
36	0.006	0.004	0.605	8.3	7818	273	0.063597	0.064534	0.000101	7933	0.064534
33	2.4	0.02	294	0.4	-1347	246	0.01096	-0.00025	0.000091	405537	0.004871
	-10	14.702	677.3	0.2	28	13172	0.000232	0.000232	0	737	0.0017
		0.002356	61.3	4	6.9	31				-42	0.08

RUN POINT	V/OR VKTS ALFS,U	MTUN QPSF BARO RHO	MTIP RPM OMEG*R TTEMPF	THETA A1 B1 CONING	LIFTH,C DRAGH,C SIDEH,C SKANGLE	PITCHH,S ROLLH,S TORQ,C HFORCE	CLRH/S CXRH/S CYRH/S	CLRHS/S CXRHS/S CYRHS/S	CMYHS/S CMXHS/S FE	THRUST POW HP VD	CTH/S CP/S CPO/S L/DR
51	0.25	0.152	0.606	6.3	7805	14	0.063896	0.064099	0.000005	7830	0.064099
5	100	33.62	292.8	-1	-626	-120	0.005121	-0.000456	-0.000044	271750	0.003298
	-4.99	14.766	674.6	4.7	-144	8863	-0.001179	-0.001179	-18.61	494	0.001406
		0.00236	57.9	4	82.84	56				-288	7.93
51	0.2	0.121	0.605	5.9	7934	-38	0.064927	0.065135	-0.000014	7960	0.065135
6	79.8	21.51	292.3	-1.2	-638	-162	0.005222	-0.000445	-0.000006	257897	0.003134
	-4.99	14.766	673.4	3.8	-156	8425	-0.001274	-0.001274	-29.67	469	0.001301
		0.002369	57.7	4.1	81.58	54				-387	6.22
51	0.15	0.091	0.605	5.6	7968	31	0.064838	0.065034	0.000011	7992	0.065034
7	60.1	12.21	292.7	-1.5	-623	-65	0.005069	-0.00059	-0.000024	252524	0.003047
	-4.99	14.765	674.3	2.9	-159	8239	-0.00129	-0.00129	-51.02	459	0.001239
		0.002376	57.5	4.1	79.03	72				-363	4.27
51	0.125	0.075	0.605	5.6	7934	-10	0.064601	0.064797	-0.000004	7958	0.064797
8	49.8	8.39	292.5	-1.8	-623	-97	0.005069	-0.000569	-0.000036	256426	0.003098
	-4.99	14.766	673.9	2.5	-177	8372	-0.00144	-0.00144	-74.16	466	0.001215
		0.002378	57.7	4.1	76.5	70				-331	3.27
51	0.101	0.061	0.605	5.9	7961	39	0.064561	0.064748	0.000015	7984	0.064748
9	40.2	5.49	292.9	-2	-612	-95	0.004966	-0.000669	-0.000035	269748	0.003242
	-4.99	14.766	674.8	2	-190	8794	-0.001541	-0.001541	-111.47	490	0.001194
		0.002381	57.5	4.1	72.42	82				-279	2.37
51	0.091	0.055	0.605	6	7946	25	0.064434	0.06462	0.000009	7969	0.06462
10	36.4	4.49	292.9	-2.2	-611	-214	0.004952	-0.000671	-0.000079	276708	0.003325
	-4.99	14.766	674.8	1.8	-211	9021	-0.001709	-0.001709	-136.04	503	0.001168
		0.002381	57.6	4	70.01	83				-258	2.04

RUN POINT	V/OR VKTS ALFS,U	MTUN QPSF BARO RHO	MTIP RPM OMEG*R TTEMPF	THETA A1 B1 CONING	LIFTH,C DRAGH,C SIDEH,C SKANGLE	PITCHH,S ROLLH,S TORQ,C HFORCE	CLRH/S CXRH/S CYRH/S	CLRHS/S CXRHS/S CYRHS/S	CMYHS/S CMXHS/S FE	THRUST POW HP VD	CTH/S CP/S CPO/S L/DR
51	0.081	0.049	0.606	6.3	8010	29	0.064787	0.064971	0.00001	8033	0.064971
11	32.3	3.55	293.2	-2.3	-610	-219	0.004934	-0.00072	-0.00008	288531	0.003455
	-4.99	14.767	675.5	1.6	-219	9397	-0.001775	-0.001775	-171.99	525	0.001113
		0.002382	57.5	4	66.65	89				-231	1.71
51	0.071	0.043	0.605	6.5	8017	60	0.064963	0.065143	0.000022	8039	0.065143
12	28.3	2.73	292.9	-2.3	-604	-149	0.004895	-0.000774	-0.000055	300015	0.003603
	-4.99	14.767	674.8	1.4	-215	9781	-0.001743	-0.001743	-221.45	545	0.00103
		0.002383	57.5	4	62.51	96				-204	1.41
51	0.06	0.036	0.605	6.8	7990	78	0.064868	0.065047	0.000029	8012	0.065047
13	24	1.95	292.6	-2.3	-600	-217	0.004874	-0.000787	-0.00008	310888	0.003744
	-4.99	14.766	674.1	1.2	-222	10146	-0.001802	-0.001802	-307.86	565	0.000829
		0.002383	57.5	4	56.72	97				-175	1.13
51	0.05	0.03	0.605	7.1	7956	47	0.064522	0.064704	0.000018	7978	0.064704
14	20.1	1.37	292.7	-2.3	-605	-274	0.00491	-0.000721	-0.000101	321256	0.003864
	-4.99	14.766	674.3	1	-224	10481	-0.001821	-0.001821	-442.88	584	0.000517
		0.002384	57.4	4	50.28	89				-150	0.9
51	0.041	0.025	0.606	7.5	8007	82	0.064778	0.064964	0.00003	8030	0.064964
15	16.3	0.9	293	-2	-613	-256	0.00496	-0.000693	-0.000094	334301	0.004007
	-4.99	14.766	675	0.8	-204	10895	-0.001648	-0.001648	-681.22	608	0.000804
		0.002385	57.3	4	42.6	86				-124	0.69
51	0.029	0.018	0.604	7.7	7915	143	0.064418	0.064603	0.000053	7938	0.064603
16	11.8	0.47	292.1	-1.5	-607	-263	0.00494	-0.000682	-0.000097	345439	0.004178
	-4.99	14.766	673	0.5	-167	11293	-0.001361	-0.001361	-1291.45	628	0.001002
		0.002385	57.3	4	32.3	84				-90	0.47

RUN POINT	V/OR VKTS ALFS,U	MTUN QPSF BARO RHO	MTIP RPM OMEG*R TTEMPF	THETA A1 B1 CONING	LIFTH,C DRAGH,C SIDEH,C SKANGLE	PITCHH,S ROLLH,S TORQ,C HFORCE	CLRH/S CXRH/S CYRH/S	CLRHS/S CXRHS/S CYRHS/S	CMYHS/S CMXHS/S FE	THRUST POW HP VD	CTH/S CP/S CPO/S L/DR
51	0.02	0.012	0.606	8	8010	-35	0.064806	0.065017	-0.000013	8036	0.065017
17	7.9	0.21	292.9	-0.9	-649	-211	0.005253	-0.000404	-0.000078	383837	0.004602
	-4.99	14.766	674.8	0.5	-121	12514	-0.000982	-0.000982	-3091.68	698	0.001396
		0.002387	57.1	4	22.06	50				-64	0.28
51	0.011	0.007	0.604	8.3	7906	99	0.064326	0.064533	0.000037	7932	0.064533
18	4.5	0.07	292.1	-0.4	-637	-130	0.00518	-0.000435	-0.000048	399495	0.00483
	-4.99	14.766	673	0.3	-57	13060	-0.000461	-0.000461	-9095.8	726	0.00166
		0.002386	57.2	3.9	13.03	53				-37	0.15
32	0.252	0.152	0.605	5.1	7882	166	0.065259	0.065272	0.000062	7884	0.065272
7	100.5	33.59	292.7	-1	-183	-192	0.001518	-0.00076	-0.000072	191990	0.002357
	-2	14.651	674.3	4.2	-172	6264	-0.001423	-0.001423	-5.46	349	0.001342
		0.002335	59	4.2	85.8	92				283	8.31
32	0.201	0.122	0.606	4.9	8013	110	0.065914	0.065939	0.000041	8016	0.065939
8	80.3	21.53	293.1	-1.2	-227	-133	0.001866	-0.000435	-0.00005	196603	0.002395
	-2	14.653	675.3	3.6	-167	6405	-0.001377	-0.001377	-10.54	357	0.001211
		0.002344	58.9	4.2	84.52	53				32	6.55
32	0.15	0.091	0.606	4.9	8041	167	0.065772	0.065799	0.000062	8044	0.065799
9	60.1	12.09	293.5	-1.7	-235	-98	0.001924	-0.000372	-0.000037	208156	0.002518
	-2	14.656	676.2	2.7	-178	6773	-0.00146	-0.00146	-19.46	378	0.001151
		0.002351	58.9	4.2	81.84	46				-68	4.42
32	0.125	0.076	0.606	5	7957	144	0.065103	0.065132	0.000054	7960	0.065132
10	50.1	8.41	293.2	-1.8	-241	-23	0.001975	-0.000299	-0.000008	218450	0.002646
	-2	14.657	675.5	2.4	-183	7115	-0.001498	-0.001498	-28.68	397	0.001132
		0.002355	58.6	4.1	79.35	36				-89	3.4

RUN POINT	V/OR VKTS ALFS,U	MTUN QPSF BARO RHO	MTIP RPM OMEG*R TTEMPF	THETA A1 B1 CONING	LIFTH,C DRAGH,C SIDEH,C SKANGLE	PITCHH,S ROLLH,S TORQ,C HFORCE	CLRH/S CXRH/S CYRH/S	CLRHS/S CXRHS/S CYRHS/S	CMYHS/S CMXHS/S FE	THRUST POW HP VD	CTH/S CP/S CPO/S L/DR
32	0.1	0.061	0.604	5.3	7927	250	0.065047	0.065072	0.000093	7930	0.065072
11	40.2	5.41	292.7	-2.1	-227	2	0.001862	-0.000409	0.000001	235550	0.002866
	-2	14.656	674.3	2	-201	7685	-0.001651	-0.001651	-41.93	428	0.001105
		0.002356	58.7	4.1	75	50				-83	2.44
32	0.08	0.048	0.604	5.9	7965	218	0.06535	0.065374	0.000081	7968	0.065374
12	32	3.44	292.5	-2.5	-225	-83	0.001844	-0.000438	-0.000031	263233	0.003205
	-2	14.657	673.9	1.7	-232	8594	-0.001903	-0.001903	-65.26	479	0.001065
		0.00236	58.3	4.1	68.71	53				-75	1.71
32	0.061	0.037	0.605	6.6	7997	193	0.065403	0.065427	0.000072	8000	0.065427
13	24.3	1.98	292.9	-2.6	-226	-155	0.001847	-0.000437	-0.000058	296857	0.003598
	-2	14.657	674.8	1.3	-260	9678	-0.002126	-0.002126	-114	540	0.000851
		0.002361	58.3	4.1	58.87	53				-62	1.14
32	0.05	0.03	0.604	7	7944	229	0.065179	0.065203	0.000085	7946	0.065203
14	20.1	1.36	292.4	-2.5	-224	-105	0.001834	-0.000442	-0.000039	307914	0.003751
	-2	14.657	673.6	1.2	-247	10056	-0.002029	-0.002029	-164.75	560	0.000501
		0.002361	58.3	4.1	51.66	54				-53	0.9
32	0.04	0.024	0.606	7.4	8072	290	0.065697	0.06572	0.000107	8075	0.06572
15	16	0.86	293.5	-2	-222	-2	0.001807	-0.000487	-0.000001	329057	0.00396
	-2	14.658	676.2	0.9	-214	10706	-0.00174	-0.00174	-258.21	598	0.000702
		0.002363	58.1	4.1	42.71	60				-42	0.67
32	0.03	0.018	0.606	7.7	8033	296	0.065497	0.065522	0.00011	8037	0.065522
16	12.1	0.49	293.2	-1.7	-228	-169	0.001862	-0.000425	-0.000063	342643	0.004136
	-2	14.659	675.5	0.6	-204	11160	-0.001661	-0.001661	-466.11	623	0.000892
		0.002363	58.1	4.1	33.35	52				-34	0.48

RUN POINT	V/OR VKTS ALFS,U	MTUN QPSF BARO RHO	MTIP RPM OMEG*R TTEMPF	THETA A1 B1 CONING	LIFTH,C DRAGH,C SIDEH,C SKANGLE	PITCHH,S ROLLH,S TORQ,C HFORCE	CLRH/S CXRH/S CYRH/S	CLRHS/S CXRHS/S CYRHS/S	CMYHS/S CMXHS/S FE	THRUST POW HP VD	CTH/S CP/S CPO/S L/DR
32	0.02	0.012	0.605	8	8000	248	0.065304	0.065334	0.000092	8004	0.065334
17	8.1	0.22	293	-1	-247	-126	0.002019	-0.000261	-0.000047	378504	0.004577
	-2	14.66	675	0.5	-151	12336	-0.001234	-0.001234	-1124.56	688	0.001347
		0.002364	58.1	4	22.91	32				-25	0.29
32	0.011	0.006	0.604	8.6	8388	143	0.068647	0.068691	0.000053	8393	0.068691
18	4.2	0.06	292.6	-0.4	-300	66	0.002458	0.000061	0.000025	427167	0.005186
	-2	14.661	674.1	0.5	-72	13941	-0.000593	-0.000593	-5006.05	777	0.001704
		0.002364	58.1	4	11.85	-7				-15	0.14
32	0	0	0.605	8.3	8025	61	0.065517	0.065556	0.000023	8030	0.065556
19	0	0	292.9	-0.2	-276	375	0.00225	-0.000038	0.000139	395314	0.004783
	-2	14.661	674.8	0	1	12888	0.00001	0.00001	0	719	0.001537
		0.002365	58	4.1	0.05	5				0	0
34	0.251	0.152	0.605	5.1	7991	227	0.06557	0.065585	0.000085	7993	0.065585
5	99.7	33.8	290.8	-0.9	-193	-175	0.00158	-0.000709	-0.000065	195370	0.002393
	-2	14.757	670	4.2	-164	6416	-0.001346	-0.001346	-5.7	355	0.001356
		0.002387	52.3	4.2	85.78	86				269	8.25
34	0.22	0.133	0.605	5	8023	84	0.065592	0.065619	0.000031	8027	0.065619
6	87.3	25.95	291	-1.2	-234	-114	0.001912	-0.000379	-0.000042	197650	0.00241
	-2	14.758	670.4	3.9	-160	6486	-0.001305	-0.001305	-9.01	359	0.001258
		0.002393	52.3	4.2	85.1	46				85	7.24
34	0.198	0.12	0.606	4.8	7980	128	0.065041	0.065069	0.000047	7984	0.065069
7	78.5	21.05	291.2	-1.2	-238	-17	0.001937	-0.000334	-0.000006	197446	0.002399
	-2	14.757	670.9	3.4	-153	6475	-0.001249	-0.001249	-11.29	359	0.001215
		0.002397	52.1	4.2	84.46	41				15	6.37

RUN POINT	V/OR VKTS ALFS,U	MTUN QPSF BARO RHO	MTIP RPM OMEG*R TTEMPF	THETA A1 B1 CONING	LIFTH,C DRAGH,C SIDEH,C SKANGLE	PITCHH,S ROLLH,S TORQ,C HFORCE	CLRH/S CXRH/S CYRH/S	CLRHS/S CXRHS/S CYRHS/S	CMYHS/S CMXHS/S FE	THRUST POW HP VD	CTH/S CP/S CPO/S L/DR
34	0.174	0.105	0.605	4.8	8028	131	0.065405	0.065435	0.000049	8031	0.065435
8	69	16.27	291.1	-1.5	-246	-111	0.002006	-0.000278	-0.000041	201520	0.002448
	-2	14.758	670.6	3.1	-176	6611	-0.001438	-0.001438	-15.13	366	0.001179
		0.002399	52.3	4.2	83.4	34				-44	5.41
34	0.152	0.092	0.606	4.8	8037	226	0.065152	0.06518	0.000083	8041	0.06518
9	60.5	12.52	291.7	-1.6	-239	-5	0.001939	-0.000336	-0.000002	207360	0.002501
	-2	14.757	672	2.7	-173	6788	-0.001403	-0.001403	-19.11	377	0.001162
		0.002402	52.3	4.2	82.05	41				-68	4.49
34	0.124	0.075	0.606	5.1	8093	203	0.065658	0.065688	0.000075	8097	0.065688
10	49.2	8.29	291.4	-1.9	-246	-21	0.001996	-0.000296	-0.000008	223148	0.002697
	-2	14.758	671.3	2.3	-195	7313	-0.001579	-0.001579	-29.68	406	0.001146
		0.002405	52.3	4.3	79.09	37				-90	3.32
34	0.102	0.062	0.606	5.4	8103	309	0.065462	0.065487	0.000113	8106	0.065487
11	40.7	5.68	291.9	-2.2	-230	-69	0.001859	-0.000426	-0.000025	239737	0.00288
	-2	14.758	672.5	2	-220	7843	-0.001776	-0.001776	-40.54	436	0.001121
		0.002406	52.3	4.2	75.3	53				-82	2.49
34	0.092	0.056	0.606	5.5	8004	264	0.064824	0.064849	0.000097	8007	0.064849
12	36.8	4.64	291.5	-2.2	-229	12	0.001856	-0.000407	0.000004	247796	0.002988
	-2	14.758	671.6	1.9	-211	8118	-0.001708	-0.001708	-49.37	451	0.001117
		0.002407	52.3	4.2	72.97	50				-81	2.13
34	0.082	0.05	0.605	5.9	8056	232	0.065406	0.065432	0.000086	8059	0.065432
13	32.8	3.68	291.1	-2.4	-233	-40	0.001888	-0.000396	-0.000015	263822	0.003194
	-2	14.758	670.6	1.8	-228	8654	-0.001852	-0.001852	-63.19	480	0.001098
		0.002408	52.3	4.2	69.56	49				-78	1.77

RUN POINT	V/OR VKTS ALFS,U	MTUN QPSF BARO RHO	MTIP RPM OMEG*R TTEMPF	THETA A1 B1 CONING	LIFTH,C DRAGH,C SIDEH,C SKANGLE	PITCHH,S ROLLH,S TORQ,C HFORCE	CLRHS/S CXRH/S CYRH/S	CLRHS/S CXRHS/S CYRHS/S	CMYHS/S CMXHS/S FE	THRUST POW HP VD	CTH/S CP/S CPO/S L/DR
34	0.072	0.044	0.607	6.2	8060	175	0.064935	0.06496	0.000064	8063	0.06496
14	28.8	2.85	292.2	-2.6	-231	-148	0.00186	-0.000407	-0.000054	282515	0.003381
	-2	14.758	673.2	1.5	-252	9233	-0.002031	-0.002031	-81.01	514	0.001065
		0.002408	52.3	4.2	65.38	51				-71	1.45
34	0.061	0.037	0.605	6.6	8027	245	0.065001	0.065022	0.00009	8029	0.065022
15	24.5	2.05	291.4	-2.6	-214	-126	0.001731	-0.000538	-0.000047	297425	0.003588
	-2	14.759	671.3	1.3	-253	9747	-0.002048	-0.002048	-104.17	541	0.000911
		0.002409	52.3	4.1	59.48	66				-58	1.15
34	0.053	0.032	0.604	6.9	8001	286	0.065006	0.065025	0.000106	8003	0.065025
16	20.9	1.5	290.9	-2.5	-207	-133	0.001678	-0.000592	-0.000049	307946	0.003733
	-2	14.759	670.2	1.1	-248	10109	-0.002014	-0.002014	-137.66	560	0.000643
		0.002409	52.3	4.1	53.47	73				-50	0.94
34	0.042	0.026	0.606	7.3	8032	259	0.064796	0.064817	0.000095	8034	0.064817
17	16.8	0.97	291.9	-2.2	-215	-103	0.001732	-0.00053	-0.000038	323498	0.003881
	-2	14.76	672.5	0.9	-231	10583	-0.001861	-0.001861	-221.77	588	0.000689
		0.00241	52.3	4.1	44.99	66				-43	0.72
34	0.032	0.02	0.606	7.7	8044	314	0.065049	0.06507	0.000115	8047	0.06507
18	12.9	0.57	291.5	-1.6	-214	-108	0.001731	-0.000541	-0.00004	341376	0.004111
	-2	14.76	671.6	0.6	-191	11183	-0.001548	-0.001548	-375.47	621	0.000901
		0.002411	52.2	4.1	35.71	67				-34	0.52
38	0.25	0.151	0.605	2.2	7832	82	0.064408	0.064728	0.000031	7870	0.064728
5	99.7	33.39	292.2	-0.7	788	-8	-0.006481	-0.000843	-0.000003	21295	0.00026
	5	14.745	673.2	3.1	-194	696	-0.001596	-0.001596	23.6	39	0.001259
		0.002359	57.3	4.3	92.78	103				1515	8.56

RUN POINT	V/OR VKTS ALFS,U	MTUN QPSF BARO RHO	MTIP RPM OMEG*R TTEMPF	THETA A1 B1 CONING	LIFTH,C DRAGH,C SIDEH,C SKANGLE	PITCHH,S ROLLH,S TORQ,C HFORCE	CLRHS/S CXRHS/S CYRHS/S	CLRHS/S CXRHS/S CYRHS/S	CMYHS/S CMXHS/S FE	THRUST POW HP VD	CTH/S CP/S CPO/S L/DR
38	0.224	0.136	0.606	2.3	7885	101	0.064566	0.06487	0.000038	7922	0.06487
6	89.3	26.86	292.5	-0.8	770	104	-0.006309	-0.000658	0.000039	37875	0.00046
	5	14.745	673.9	3	-175	1237	-0.001433	-0.001433	28.68	69	0.001174
		0.002364	57.1	4.3	92.21	80				1242	7.72
38	0.198	0.12	0.606	2.5	7908	105	0.064571	0.06486	0.000039	7943	0.06486
7	79	21.08	292.6	-1.1	751	12	-0.006134	-0.000483	0.000005	55654	0.000674
	5	14.746	674.1	2.6	-179	1816	-0.001462	-0.001462	35.64	101	0.0011
		0.002369	56.9	4.3	91.44	59				1008	6.77
38	0.174	0.105	0.605	2.7	7877	171	0.064473	0.064755	0.000064	7912	0.064755
8	69.2	16.19	292	-1.4	739	25	-0.006046	-0.000404	0.000009	73989	0.0009
	5	14.746	672.7	2.3	-172	2420	-0.001406	-0.001406	45.61	135	0.001055
		0.002374	56.7	4.3	90.38	49				824	5.74
38	0.151	0.091	0.606	2.9	7959	98	0.064804	0.065069	0.000036	7991	0.065069
9	60.3	12.3	292.6	-1.6	722	83	-0.005881	-0.000211	0.000031	96002	0.00116
	5	14.746	674.1	2.2	-166	3133	-0.001349	-0.001349	58.7	175	0.001007
		0.002376	56.7	4.3	88.85	26				663	4.78
38	0.151	0.091	0.606	2.9	7967	107	0.064823	0.06509	0.00004	8000	0.06509
10	60.3	12.3	292.7	-1.6	724	70	-0.005887	-0.000215	0.000026	96217	0.001161
	5	14.747	674.3	2.2	-166	3139	-0.001347	-0.001347	58.81	175	0.001008
		0.002376	56.7	4.3	88.84	26				664	4.77
38	0.125	0.076	0.605	3.3	7938	195	0.064755	0.06502	0.000072	7971	0.06502
11	49.9	8.42	292.1	-2	720	48	-0.005872	-0.000206	0.000018	123985	0.001503
	5	14.748	673	1.9	-177	4053	-0.001442	-0.001442	85.44	225	0.000983
		0.00238	56.5	4.3	86.06	25				519	3.62

RUN POINT	V/OR VKTS ALFS,U	MTUN QPSF BARO RHO	MTIP RPM OMEG*R TTEMPF	THETA A1 B1 CONING	LIFTH,C DRAGH,C SIDEH,C SKANGLE	PITCHH,S ROLLH,S TORQ,C HFORCE	CLRH/S CXRH/S CYRH/S	CLRHS/S CXRHS/S CYRHS/S	CMYHS/S CMXHS/S FE	THRUST POW HP VD	CTH/S CP/S CPO/S L/DR
38	0.101	0.061	0.606	4	8025	187	0.065096	0.065354	0.000069	8057	0.065354
12	40.5	5.56	292.8	-2.4	715	75	-0.005798	-0.000103	0.000027	159441	0.001917
	5	14.748	674.6	1.8	-191	5200	-0.001546	-0.001546	128.46	290	0.000941
		0.002382	56.5	4.2	81.48	13				398	2.63
38	0.09	0.054	0.605	4.4	8045	205	0.065483	0.065745	0.000076	8077	0.065745
13	35.9	4.39	292.2	-2.7	720	-41	-0.005857	-0.000127	-0.000015	181827	0.002199
	5	14.749	673.2	1.7	-218	5942	-0.001772	-0.001772	164.03	331	0.000947
		0.002383	56.4	4.2	78.09	16				348	2.16
38	0.081	0.049	0.604	4.8	7945	282	0.064736	0.065004	0.000104	7978	0.065004
14	32.5	3.58	292	-2.8	724	-24	-0.005902	-0.000238	-0.000009	197986	0.002398
	5	14.749	672.7	1.6	-222	6475	-0.00181	-0.00181	202.5	360	0.000954
		0.002384	56.3	4.2	74.93	29				316	1.83
38	0.071	0.043	0.609	5.2	8017	331	0.064338	0.064612	0.000121	8051	0.064612
15	28.4	2.75	294.2	-3	742	-92	-0.005952	-0.000322	-0.000033	227123	0.002689
	5	14.749	677.8	1.4	-247	7372	-0.001979	-0.001979	269.87	413	0.000925
		0.002385	56.4	4.2	69.8	40				277	1.46
38	0.06	0.037	0.606	5.9	8005	137	0.064876	0.065144	0.000051	8038	0.065144
16	24.1	1.97	292.7	-3.1	729	23	-0.005904	-0.000227	0.000009	258166	0.003103
	5	14.749	674.3	1.4	-257	8423	-0.002086	-0.002086	369.7	469	0.000847
		0.002386	56.3	4.2	62.81	28				228	1.13
38	0.052	0.031	0.604	6.4	7982	299	0.065001	0.065297	0.000111	8018	0.065297
17	20.6	1.44	291.9	-3.1	766	-24	-0.00624	-0.000551	-0.000009	280734	0.0034
	5	14.75	672.5	1	-272	9184	-0.002215	-0.002215	532.62	510	0.000661
		0.002387	56.1	4.2	55.9	68				204	0.9

RUN POINT	V/OR VKTS ALFS,U	MTUN QPSF BARO RHO	MTIP RPM OMEG*R TTEMPF	THETA A1 B1 CONING	LIFTH,C DRAGH,C SIDEH,C SKANGLE	PITCHH,S ROLLH,S TORQ,C HFORCE	CLRH/S CXRH/S CYRH/S	CLRHS/S CXRHS/S CYRHS/S	CMYHS/S CMXHS/S FE	THRUST POW HP VD	CTH/S CP/S CPO/S L/DR
38	0.042	0.025	0.606	7	8001	331	0.064652	0.064951	0.000122	8038	0.064951
18	16.8	0.96	293	-2.8	773	-175	-0.006248	-0.00059	-0.000064	305260	0.003654
	5	14.751	675	0.8	-282	9949	-0.002278	-0.002278	805.45	555	0.000453
		0.002388	56.1	4.1	47.11	73				166	0.69
38	0.031	0.019	0.605	7.5	7980	201	0.064782	0.065062	0.000074	8014	0.065062
19	12.4	0.52	292.3	-1.9	745	-66	-0.006047	-0.000378	-0.000024	322922	0.003893
	5	14.751	673.4	0.8	-216	10550	-0.001751	-0.001751	1432.42	587	0.000683
		0.002388	56.1	4.1	35.58	47				117	0.49
38	0.021	0.013	0.604	7.8	7992	158	0.065128	0.065404	0.000058	8026	0.065404
20	8.4	0.24	291.7	-1.4	738	-113	-0.006012	-0.000313	-0.000042	356430	0.004322
	5	14.752	672	0.5	-173	11668	-0.00141	-0.00141	3073.77	648	0.001087
		0.002389	56	4.1	24.42	38				78	0.31
38	0.01	0.006	0.605	8.5	8006	36	0.064959	0.065216	0.000013	8038	0.065216
21	3.8	0.05	292.3	-0.3	713	15	-0.005783	-0.0001	0.000006	408531	0.004922
	5	14.753	673.4	0.3	-54	13347	-0.000434	-0.000434	14255.88	743	0.001701
		0.00239	55.9	4.2	11.16	12				34	0.13
37	0.251	0.152	0.606	9.8	9581	150	0.078956	0.08011	0.000056	9721	0.08011
5	100.3	33.5	293.2	-1.5	-1645	-297	0.013553	-0.000364	-0.000111	493134	0.006016
	-10	14.706	675.5	5.9	-182	16061	-0.001499	-0.001499	-49.09	897	0.001689
		0.002338	60.3	4.7	77.36	44				-1306	7.55
37	0.2	0.121	0.604	8.9	9645	194	0.079486	0.080654	0.000073	9787	0.080654
6	80	21.38	292.6	-1.7	-1660	-343	0.013683	-0.000327	-0.000129	441860	0.005402
	-10	14.707	674.1	4.6	-211	14421	-0.00174	-0.00174	-77.67	803	0.001482
		0.002348	60	4.8	75.88	40				-1166	5.98

RUN POINT	V/OR VKTS ALFS,U	MTUN QPSF BARO RHO	MTIP RPM OMEG*R TTEMPF	THETA A1 B1 CONING	LIFTH,C DRAGH,C SIDEH,C SKANGLE	PITCHH,S ROLLH,S TORQ,C HFORCE	CLRH/S CXRH/S CYRH/S	CLRHS/S CXRHS/S CYRHS/S	CMYHS/S CMXHS/S FE	THRUST POW HP VD	CTH/S CP/S CPO/S L/DR
37	0.15	0.091	0.605	8.4	9802	109	0.080108	0.081279	0.000041	9946	0.081279
7	60.1	12.12	293.4	-1.8	-1683	-301	0.013757	-0.000363	-0.000112	416204	0.005032
	-10	14.708	675.9	3.6	-234	13546	-0.001911	-0.001911	-138.9	757	0.001368
		0.002355	59.9	4.9	72.82	44				-944	4.05
37	0.1	0.061	0.606	8.3	9729	114	0.079104	0.080223	0.000042	9866	0.080223
8	40.3	5.45	293.8	-2.1	-1644	-196	0.013367	-0.000572	-0.000072	408140	0.004903
	-10	14.708	676.9	2.4	-247	13266	-0.00201	-0.00201	-301.53	742	0.00123
		0.00236	59.7	4.8	65.51	70				-653	2.23
37	0.091	0.055	0.607	8.4	9707	175	0.078666	0.079761	0.000065	9842	0.079761
9	36.4	4.47	294.2	-2.1	-1628	-178	0.013189	-0.000671	-0.000065	410714	0.004911
	-10	14.707	677.8	2.2	-250	13331	-0.002029	-0.002029	-364.23	747	0.001164
		0.002362	59.5	4.8	63.02	83				-591	1.92
37	0.081	0.049	0.606	8.5	9721	127	0.078966	0.08008	0.000047	9858	0.08008
10	32.3	3.52	293.8	-2.2	-1640	-259	0.013323	-0.000591	-0.000096	417157	0.005006
	-10	14.708	676.9	2.1	-269	13559	-0.002182	-0.002182	-466.48	758	0.001039
		0.002362	59.5	4.8	59.62	73				-531	1.62
37	0.071	0.043	0.606	8.7	9699	145	0.07872	0.079829	0.000053	9836	0.079829
11	28.4	2.71	293.9	-2.2	-1636	-288	0.013276	-0.000596	-0.000106	422424	0.005063
	-10	14.708	677.1	1.8	-276	13725	-0.002236	-0.002236	-604.17	768	0.000847
		0.002363	59.5	4.8	55.61	73				-468	1.35
37	0.06	0.036	0.606	8.9	9715	176	0.079013	0.080131	0.000065	9853	0.080131
12	23.9	1.93	293.5	-2.2	-1642	-354	0.013352	-0.000572	-0.000131	431984	0.005196
	-10	14.708	676.2	1.5	-282	14055	-0.002295	-0.002295	-850.74	785	0.00049
		0.002364	59.3	4.8	49.99	70				-398	1.07

RUN POINT	V/OR VKTS ALFS,U	MTUN QPSF BARO RHO	MTIP RPM OMEG*R TTEMPF	THETA A1 B1 CONING	LIFTH,C DRAGH,C SIDEH,C SKANGLE	PITCHH,S ROLLH,S TORQ,C HFORCE	CLRH/S CXRH/S CYRH/S	CLRHS/S CXRHS/S CYRHS/S	CMYHS/S CMXHS/S FE	THRUST POW HP VD	CTH/S CP/S CPO/S L/DR
37	0.05	0.03	0.604	9.1	9732	185	0.07946	0.080587	0.000069	9870	0.080587
13	20.1	1.36	292.9	-2.1	-1646	-270	0.013443	-0.000559	-0.0001	441017	0.005336
	-10	14.708	674.8	1.3	-260	14378	-0.002119	-0.002119	-1213.4	802	0.000912
		0.002365	59.3	4.8	44.05	68				-336	0.86
37	0.041	0.025	0.605	9.3	9658	370	0.07872	0.079803	0.000137	9791	0.079803
14	16.3	0.89	293.1	-1.8	-1610	-271	0.013123	-0.000746	-0.0001	446368	0.005388
	-10	14.708	675.3	0.9	-232	14543	-0.001894	-0.001894	-1809.06	812	0.001028
		0.002366	59.2	4.8	37.39	91				-269	0.66
37	0.029	0.018	0.603	9.5	9565	358	0.078314	0.079412	0.000133	9699	0.079412
15	11.7	0.46	292.4	-1.3	-1609	-193	0.013176	-0.000623	-0.000072	463439	0.005633
	-10	14.707	673.6	0.7	-173	15135	-0.001413	-0.001413	-3498.47	843	0.001305
		0.002366	59.1	4.7	28.2	76				-196	0.44
37	0.019	0.012	0.605	9.8	9732	258	0.079134	0.080282	0.000096	9873	0.080282
16	7.7	0.2	293.4	-1	-1664	-103	0.013533	-0.000414	-0.000038	507230	0.006102
	-10	14.707	675.9	0.5	-135	16509	-0.001099	-0.001099	-8321.58	922	0.001703
		0.002366	59.1	4.7	19.01	51				-131	0.26
37	0.011	0.007	0.607	10	9722	173	0.078709	0.079897	0.000064	9868	0.079897
17	4.6	0.07	294	-0.4	-1696	-225	0.013728	-0.000148	-0.000083	537634	0.006426
	-10	14.707	677.3	0.4	-69	17463	-0.00056	-0.00056	-24223.27	978	0.002059
		0.002367	59	4.7	11.47	18				-79	0.14
37	0.011	0.007	0.606	10	9934	459	0.080574	0.081746	0.000169	10078	0.081746
18	4.6	0.07	293.7	-0.4	-1701	-57	0.013798	-0.000403	-0.000021	544416	0.006526
	-10	14.707	676.6	0.4	-61	17701	-0.000497	-0.000497	-24301.68	990	0.002006
		0.002368	58.9	4.7	11.35	50				-78	0.14

RUN POINT	V/OR VKTS ALFS,U	MTUN QPSF BARO RHO	MTIP RPM OMEG*R TTEMPF	THETA A1 B1 CONING	LIFTH,C DRAGH,C SIDEH,C SKANGLE	PITCHH,S ROLLH,S TORQ,C HFORCE	CLRH/S CXRH/S CYRH/S	CLRHS/S CXRHS/S CYRHS/S	CMYHS/S CMXHS/S FE	THRUST POW HP VD	CTH/S CP/S CPO/S L/DR
53	0.25	0.151	0.606	7.9	9668	254	0.07911	0.0794	0.000094	9704	0.0794
5	100.1	33.51	293.6	-1.3	-829	-185	0.00678	-0.000141	-0.000069	343811	0.004159
	-5	14.771	676.4	5.5	-232	11182	-0.001897	-0.001897	-24.72	625	0.001528
		0.002348	60.9	4.8	82.31	17				-447	8.01
53	0.227	0.137	0.605	7.6	9659	305	0.079186	0.079473	0.000114	9694	0.079473
6	90.9	27.68	293.1	-1.5	-823	-230	0.006748	-0.000179	-0.000086	330068	0.004007
	-5	14.77	675.3	4.9	-245	10754	-0.002007	-0.002007	-29.74	600	0.001442
		0.002352	60.9	4.8	81.75	22				-467	7.27
53	0.2	0.121	0.605	7.4	9793	235	0.080086	0.080382	0.000087	9829	0.080382
7	80	21.47	293.2	-1.6	-843	-127	0.006893	-0.000113	-0.000047	328267	0.003974
	-5	14.77	675.5	4.5	-235	10691	-0.001923	-0.001923	-39.26	597	0.001396
		0.002356	60.9	4.9	80.78	14				-483	6.16
53	0.176	0.107	0.606	7.2	9768	351	0.079401	0.079678	0.00013	9802	0.079678
8	70.7	16.82	293.9	-1.8	-817	-222	0.006642	-0.000303	-0.000082	321909	0.003865
	-5	14.77	677.1	3.8	-260	10459	-0.002117	-0.002117	-48.58	585	0.001356
		0.002359	60.9	4.9	79.66	37				-450	5.2
53	0.15	0.091	0.606	7.1	9769	270	0.079238	0.079517	0.0001	9804	0.079517
9	60.2	12.19	294	-1.9	-820	-33	0.00665	-0.000281	-0.000012	325467	0.003897
	-5	14.77	677.3	3.4	-238	10571	-0.001933	-0.001933	-67.25	592	0.001334
		0.002363	60.8	4.9	77.72	35				-419	4.1
53	0.125	0.075	0.604	7.3	9777	361	0.079648	0.07991	0.000134	9809	0.07991
10	49.9	8.38	293.2	-2.1	-796	-112	0.006484	-0.000483	-0.000042	333239	0.004019
	-5	14.77	675.5	2.8	-272	10853	-0.002216	-0.002216	-94.93	606	0.001307
		0.002365	60.8	4.9	74.66	59				-358	3.09

RUN POINT	V/OR VKTS ALFS,U	MTUN QPSF BARO RHO	MTIP RPM OMEG*R TTEMPF	THETA A1 B1 CONING	LIFTH,C DRAGH,C SIDEH,C SKANGLE	PITCHH,S ROLLH,S TORQ,C HFORCE	CLRH/S CXRH/S CYRH/S	CLRHS/S CXRHS/S CYRHS/S	CMYHS/S CMXHS/S FE	THRUST POW HP VD	CTH/S CP/S CPO/S L/DR
53	0.096	0.058	0.605	7.6	9713	163	0.078909	0.079179	0.00006	9746	0.079179
12	38.5	5	293.5	-2.4	-805	-85	0.00654	-0.000363	-0.000031	359934	0.004325
	-5	14.77	676.2	2.3	-281	11711	-0.002285	-0.002285	-160.96	654	0.001273
		0.002367	60.9	4.8	68.77	45				-298	2.05
53	0.091	0.055	0.604	7.7	9778	258	0.079507	0.079765	0.000095	9810	0.079765
13	36.6	4.52	293.3	-2.5	-792	-150	0.006437	-0.000517	-0.000055	366339	0.004408
	-5	14.769	675.7	2.2	-299	11927	-0.00243	-0.00243	-175.16	666	0.001234
		0.002368	60.7	4.8	67.26	64				-279	1.9
53	0.08	0.049	0.606	8	9833	274	0.079481	0.079733	0.000101	9864	0.079733
14	32.2	3.51	294.1	-2.5	-786	-116	0.006355	-0.000596	-0.000043	383981	0.004581
	-5	14.769	677.6	1.9	-299	12468	-0.002416	-0.002416	-224.26	698	0.001128
		0.002369	60.6	4.8	63.26	74				-246	1.57
53	0.07	0.043	0.606	8.3	9806	333	0.079335	0.079576	0.000123	9835	0.079576
15	28.3	2.7	293.9	-2.6	-769	-210	0.006225	-0.000713	-0.000077	395610	0.004727
	-5	14.769	677.1	1.6	-315	12854	-0.002552	-0.002552	-285.26	719	0.000948
		0.00237	60.5	4.8	58.85	88				-215	1.3
53	0.06	0.036	0.607	8.6	9874	315	0.079439	0.079684	0.000115	9905	0.079684
16	24	1.95	294.7	-2.6	-780	-263	0.006279	-0.000668	-0.000096	416111	0.004931
	-5	14.769	678.9	1.4	-322	13483	-0.002588	-0.002588	-400.22	757	0.000605
		0.002371	60.5	4.8	52.84	83				-186	1.04
53	0.051	0.031	0.605	8.9	9807	350	0.079371	0.079614	0.000129	9837	0.079614
17	20.3	1.39	293.8	-2.4	-772	-196	0.006249	-0.000692	-0.000072	424001	0.00507
	-5	14.768	676.9	1.1	-297	13781	-0.002401	-0.002401	-556.44	771	0.000726
		0.002371	60.5	4.8	46.7	86				-158	0.84

RUN POINT	V/OR VKTS ALFS,U	MTUN QPSF BARO RHO	MTIP RPM OMEG*R TTEMPF	THETA A1 B1 CONING	LIFTH,C DRAGH,C SIDEH,C SKANGLE	PITCHH,S ROLLH,S TORQ,C HFORCE	CLRH/S CXRH/S CYRH/S	CLRHS/S CXRHS/S CYRHS/S	CMYHS/S CMXHS/S FE	THRUST POW HP VD	CTH/S CP/S CPO/S L/DR
53	0.041	0.025	0.606	9.2	9868	402	0.079736	0.079979	0.000148	9898	0.079979
18	16.3	0.9	294	-1.8	-775	-103	0.006262	-0.000711	-0.000038	442296	0.005277
	-5	14.769	677.3	0.9	-251	14366	-0.002029	-0.002029	-861.12	804	0.000902
		0.002372	60.5	4.8	39.01	88				-128	0.65
53	0.029	0.018	0.604	9.5	9801	328	0.079641	0.0799	0.000121	9833	0.0799
19	11.8	0.47	293.1	-1.5	-793	-169	0.006445	-0.000521	-0.000062	469060	0.005645
	-5	14.769	675.3	0.7	-205	15282	-0.001667	-0.001667	-1687.59	853	0.001277
		0.002373	60.3	4.7	29.29	64				-96	0.43
53	0.021	0.012	0.607	9.8	9885	248	0.079609	0.079883	0.000091	9919	0.079883
20	8.2	0.23	294.4	-1	-822	19	0.006622	-0.000342	0.000007	512527	0.006086
	-5	14.769	678.2	0.7	-140	16625	-0.001127	-0.001127	-3574.7	932	0.001719
		0.002373	60.3	4.7	20.83	42				-69	0.27
53	0.014	0.009	0.606	9.9	9781	430	0.078847	0.079123	0.000158	9815	0.079123
21	5.7	0.11	294.2	-0.5	-820	-72	0.00661	-0.000287	-0.000026	534658	0.006359
	-5	14.769	677.8	0.4	-82	17354	-0.000665	-0.000665	-7454.39	972	0.002055
		0.002374	60.1	4.6	14.65	36				-48	0.18
32	0	0	0.605	10.1	9848	114	0.080286	0.080324	0.000042	9852	0.080324
20	0	0	293.2	-0.1	-305	314	0.002484	-0.00032	0.000116	518183	0.006254
	-2	14.661	675.5	-0.2	9	16877	0.000077	0.000077	0	942	0.001852
		0.002363	58.4	4.8	0.04	39				0	0
32	0.02	0.012	0.606	9.8	9923	274	0.080676	0.080711	0.000101	9928	0.080711
21	8.1	0.22	293.5	-1.1	-296	-87	0.002403	-0.000414	-0.000032	504451	0.006065
	-2	14.662	676.2	0.7	-164	16413	-0.001332	-0.001332	-1343.65	917	0.001631
		0.002365	57.9	4.8	20.65	51				-24	0.27

RUN POINT	V/OR VKTS ALFS,U	MTUN QPSF BARO RHO	MTIP RPM OMEG*R TTEMPF	THETA A1 B1 CONING	LIFTH,C DRAGH,C SIDEH,C SKANGLE	PITCHH,S ROLLH,S TORQ,C HFORCE	CLRH/S CXRH/S CYRH/S	CLRHS/S CXRHS/S CYRHS/S	CMYHS/S CMXHS/S FE	THRUST POW HP VD	CTH/S CP/S CPO/S L/DR
32	0.04	0.024	0.606	9.2	9904	349	0.080608	0.080631	0.000129	9907	0.080631
22	16.1	0.87	293.3	-2	-254	-113	0.002071	-0.000744	-0.000042	429532	0.005174
	-2	14.663	675.7	1	-265	13985	-0.002156	-0.002156	-292.45	781	0.000746
		0.002366	57.7	4.9	39.29	91				-40	0.64
32	0.04	0.024	0.606	9.2	9896	354	0.080675	0.080698	0.000131	9899	0.080698
23	16.1	0.87	293	-2	-253	-105	0.002064	-0.000753	-0.000039	428727	0.005178
	-2	14.663	675	1	-264	13973	-0.002155	-0.002155	-290.98	780	0.000744
		0.002367	57.5	4.9	39.31	92				-40	0.64
32	0.06	0.036	0.603	8.4	9814	216	0.0806	0.080626	0.000081	9817	0.080626
24	24	1.95	291.9	-2.8	-262	-173	0.002149	-0.000666	-0.000065	387615	0.004734
	-2	14.664	672.5	1.5	-329	12681	-0.0027	-0.0027	-134.15	705	0.000579
		0.002367	57.3	4.9	54.61	81				-59	1.06
32	0.08	0.048	0.605	7.6	9845	306	0.080372	0.080393	0.000113	9847	0.080393
25	32	3.45	292.9	-2.8	-244	-187	0.001992	-0.000814	-0.000007	351219	0.004249
	-2	14.664	674.8	1.8	-327	11451	-0.002671	-0.002671	-70.63	639	0.001073
		0.002365	57.5	4.9	65.25	100				-67	1.57
32	0.1	0.061	0.607	7.1	9842	290	0.07987	0.079896	0.000107	9846	0.079896
26	40	5.4	293.8	-2.6	-263	-166	0.002131	-0.000658	-0.000061	314801	0.003774
	-2	14.665	676.9	2.2	-300	10232	-0.002434	-0.002434	-48.63	572	0.001172
		0.002365	57.3	5	72.22	81				-81	2.24
32	0.125	0.076	0.605	6.6	9836	411	0.080441	0.080465	0.000153	9838	0.080465
27	50.1	8.44	292.8	-2.3	-256	-196	0.002097	-0.000711	-0.000073	280579	0.003402
	-2	14.666	674.6	2.6	-275	9151	-0.002248	-0.002248	-30.4	510	0.001207
		0.002362	57.4	5	77.46	87				-80	3.21

RUN POINT	V/OR VKTS ALFS,U	MTUN QPSF BARO RHO	MTIP RPM OMEG*R TTEMPF	THETA A1 B1 CONING	LIFTH,C DRAGH,C SIDEH,C SKANGLE	PITCHH,S ROLLH,S TORQ,C HFORCE	CLRH/S CXRH/S CYRH/S	CLRHS/S CXRHS/S CYRHS/S	CMYHS/S CMXHS/S FE	THRUST POW HP VD	CTH/S CP/S CPO/S L/DR
32	0.201	0.122	0.605	6.3	9673	260	0.079663	0.079693	0.000097	9676	0.079693
28	80.4	21.65	292.3	-1.6	-275	-181	0.002266	-0.000516	-0.000068	240441	0.002941
	-2	14.666	673.4	4	-237	7855	-0.001951	-0.001951	-12.71	437	0.001306
		0.002354	57.3	5	83.83	63				-13	6.46
32	0.251	0.152	0.605	6.6	9668	204	0.080054	0.08008	0.000077	9671	0.08008
29	100.1	33.47	292.1	-1.3	-257	-168	0.002131	-0.000664	-0.000063	238975	0.00294
	-2	14.666	673	5	-251	7813	-0.002079	-0.002079	-7.69	434	0.001451
		0.002345	57.6	5	85.29	80				151	8.36
32	0.1	0.061	0.606	7.1	9851	103	0.080374	0.080408	0.000038	9855	0.080408
30	40	5.39	293	-2.4	-289	-76	0.002357	-0.00045	-0.000028	317966	0.003843
	-2	14.666	675	2.4	-287	10363	-0.002344	-0.002344	-53.59	578	0.001192
		0.002365	57.3	5	72.18	55				-92	2.23
32	0.08	0.049	0.603	7.6	9769	136	0.08027	0.080297	0.000051	9772	0.080297
31	32.1	3.46	291.9	-2.7	-264	-93	0.002172	-0.00063	-0.000035	349327	0.004268
	-2	14.665	672.5	2	-309	11428	-0.002537	-0.002537	-76.31	635	0.001099
		0.002366	57.3	4.9	65.43	77				-74	1.58
32	0.03	0.018	0.609	9.3	9817	187	0.079117	0.079146	0.000068	9820	0.079146
32	12.2	0.5	294.6	-1.6	-274	-131	0.002209	-0.000553	-0.000048	454796	0.005401
	-2	14.665	678.7	0.8	-229	14742	-0.001845	-0.001845	-548.26	827	0.001095
		0.002368	57.3	4.8	30.69	69				-34	0.45
35	0.251	0.152	0.605	6.8	9787	2	0.080374	0.0804	0.000001	9790	0.0804
5	99.4	33.62	290.7	-1.2	-263	-222	0.002158	-0.000662	-0.000083	246917	0.003028
	-2.01	14.756	669.7	5.2	-236	8111	-0.001935	-0.001935	-7.82	449	0.001523
		0.002387	52.3	5.1	85.26	81				145	8.1

RUN POINT	V/OR VKTS ALFS,U	MTUN QPSF BARO RHO	MTIP RPM OMEG*R TTEMPF	THETA A1 B1 CONING	LIFTH,C DRAGH,C SIDEH,C SKANGLE	PITCHH,S ROLLH,S TORQ,C HFORCE	CLRH/S CXRH/S CYRH/S	CLRHS/S CXRHS/S CYRHS/S	CMYHS/S CMXHS/S FE	THRUST POW HP VD	CTH/S CP/S CPO/S L/DR
35	0.222	0.134	0.605	6.6	9859	-11	0.080688	0.080721	-0.000004	9863	0.080721
6	88.2	26.49	290.9	-1.4	-287	-169	0.002352	-0.000479	-0.000063	248078	0.00303
	-2.01	14.756	670.2	4.7	-235	8144	-0.001927	-0.001927	-10.85	451	0.001411
		0.002392	52.3	5.1	84.51	59				28	7.15
35	0.198	0.12	0.606	6.4	9816	50	0.080038	0.080072	0.000018	9820	0.080072
7	78.7	21.11	291.2	-1.7	-291	-263	0.002372	-0.000437	-0.000098	248632	0.003022
	-2.01	14.756	670.9	4.2	-257	8153	-0.002098	-0.002098	-13.78	452	0.001342
		0.002396	52.2	5.1	83.65	54				-30	6.2
35	0.173	0.105	0.605	6.4	9829	23	0.080091	0.080128	0.000009	9834	0.080128
8	68.7	16.14	291.1	-1.8	-301	-107	0.002453	-0.000358	-0.000039	256110	0.003112
	-2.01	14.755	670.6	3.8	-239	8401	-0.001948	-0.001948	-18.65	466	0.001301
		0.002399	52.2	5.1	82.34	44				-76	5.16
35	0.151	0.092	0.605	6.4	9779	118	0.07967	0.079704	0.000044	9783	0.079704
9	60.1	12.35	291	-2	-291	-109	0.00237	-0.000426	-0.00004	263287	0.0032
	-2.01	14.755	670.4	3.3	-248	8640	-0.002023	-0.002023	-23.55	479	0.001272
		0.002401	52.3	5.1	80.7	52				-89	4.24
35	0.125	0.076	0.606	6.7	9898	136	0.080262	0.080296	0.00005	9902	0.080296
10	49.8	8.51	291.5	-2.2	-292	-58	0.002369	-0.000447	-0.000021	288160	0.003479
	-2.01	14.755	671.6	2.9	-265	9440	-0.00215	-0.00215	-34.34	524	0.001259
		0.002404	52.2	5.1	77.48	55				-97	3.16
35	0.102	0.062	0.605	7.1	9873	163	0.080267	0.080298	0.00006	9877	0.080298
11	40.4	5.61	291	-2.5	-280	-94	0.00228	-0.000537	-0.000035	314400	0.003813
	-2.01	14.755	670.4	2.4	-295	10317	-0.0024	-0.0024	-50.03	572	0.001214
		0.002406	52.2	5	72.67	66				-88	2.28

RUN POINT	V/OR VKTS ALFS,U	MTUN QPSF BARO RHO	MTIP RPM OMEG*R TTEMPF	THETA A1 B1 CONING	LIFTH,C DRAGH,C SIDEH,C SKANGLE	PITCHH,S ROLLH,S TORQ,C HFORCE	CLRHS/S CXRHS/S CYRHS/S	CLRHS/S CXRHS/S CYRHS/S	CMYHS/S CMXHS/S FE	THRUST POW HP VD	CTH/S CP/S CPO/S L/DR
35	0.092	0.055	0.604	7.4	9900	127	0.08058	0.08061	0.000047	9904	0.08061
12	36.4	4.54	290.8	-2.5	-282	-92	0.002292	-0.000535	-0.000034	333473	0.004051
	-2.01	14.754	670	2.2	-305	10951	-0.002487	-0.002487	-62.03	606	0.001193
		0.002407	52.2	5	69.61	66				-85	1.92
35	0.082	0.05	0.606	7.6	9853	188	0.079723	0.079749	0.000069	9856	0.079749
13	32.8	3.69	291.6	-2.7	-263	-163	0.002128	-0.00067	-0.00006	348482	0.004197
	-2.01	14.754	671.8	2	-325	11412	-0.00263	-0.00263	-71.27	634	0.001137
		0.002408	52.1	5	66.35	83				-74	1.63
35	0.072	0.043	0.607	8	9951	215	0.080292	0.080315	0.000079	9954	0.080315
14	28.6	2.8	292	-2.8	-254	-178	0.002049	-0.000768	-0.000065	375644	0.004505
	-2.01	14.754	672.7	1.7	-342	12285	-0.002761	-0.002761	-90.72	683	0.000995
		0.002408	52.2	5	61.26	95				-64	1.32
35	0.061	0.037	0.606	8.4	9948	246	0.080467	0.080489	0.00009	9951	0.080489
15	24.2	2	291.6	-2.8	-250	-179	0.002025	-0.000799	-0.000066	395367	0.00476
	-2.01	14.755	671.8	1.4	-342	12947	-0.002763	-0.002763	-125.09	719	0.000647
		0.002408	52.2	5	54.84	99				-56	1.05
35	0.052	0.031	0.606	8.7	9858	156	0.079669	0.079695	0.000057	9861	0.079695
16	20.5	1.45	291.7	-2.7	-264	-201	0.002137	-0.000659	-0.000074	406890	0.004893
	-2.01	14.755	672	1.3	-328	13320	-0.002649	-0.002649	-182.49	740	0.000542
		0.002409	52.2	4.9	48.74	82				-52	0.86
35	0.042	0.025	0.606	9.1	9893	316	0.08003	0.080049	0.000116	9895	0.080049
17	16.5	0.94	291.5	-2.3	-242	-172	0.001959	-0.000849	-0.000063	424172	0.00511
	-2.01	14.755	671.6	1	-294	13896	-0.002379	-0.002379	-258.3	771	0.000729
		0.00241	52.1	4.9	40.62	105				-39	0.66

RUN POINT	V/OR VKTS ALFS,U	MTUN QPSF BARO RHO	MTIP RPM OMEG*R TTEMPF	THETA A1 B1 CONING	LIFTH,C DRAGH,C SIDEH,C SKANGLE	PITCHH,S ROLLH,S TORQ,C HFORCE	CLRH/S CXRH/S CYRH/S	CLRHS/S CXRHS/S CYRHS/S	CMYHS/S CMXHS/S FE	THRUST POW HP VD	CTH/S CP/S CPO/S L/DR
35	0.031	0.019	0.604	9.4	9828	153	0.079883	0.079912	0.000057	9832	0.079912
18	12.4	0.53	290.8	-1.7	-276	-176	0.002246	-0.000557	-0.000065	447487	0.005429
	-2.01	14.754	670	0.8	-240	14695	-0.00195	-0.00195	-521.33	814	0.00106
		0.00241	52.1	4.9	31.51	69				-35	0.47
35	0.031	0.019	0.604	9.4	9827	159	0.079985	0.080014	0.000059	9831	0.080014
19	12.3	0.52	290.6	-1.7	-275	-188	0.002242	-0.000565	-0.00007	446745	0.005431
	-2.01	14.754	669.5	0.8	-240	14680	-0.001954	-0.001954	-529.72	812	0.001054
		0.00241	52.1	4.9	31.24	69				-34	0.46
48	0.013	0.008	0.603	10.3	9842	30	0.080247	0.080247	0.000011	9842	0.080247
5	5.2	0.09	292.5	-0.3	32	-243	-0.000257	-0.000257	-0.00009	544484	0.006588
	0	14.754	673.9	0.3	-50	17776	-0.00041	-0.00041	350.88	990	0.002191
		0.002375	59.5	4.6	13.45	32				2	0.16
48	0.021	0.013	0.606	10.1	10217	520	0.082654	0.082654	0.000191	10217	0.082654
6	8.4	0.24	293.6	-0.8	139	34	-0.001121	-0.001121	0.000012	529818	0.006336
	0	14.754	676.4	0.3	-122	17232	-0.00099	-0.00099	577.15	963	0.001741
		0.002375	59.3	4.8	21.39	139				12	0.27
48	0.031	0.019	0.606	9.8	10348	307	0.083695	0.083695	0.000113	10348	0.083695
7	12.3	0.51	293.6	-1.4	124	-50	-0.001005	-0.001005	-0.000019	485660	0.005807
	0	14.754	676.4	0.7	-198	15796	-0.001604	-0.001604	243.69	883	0.001124
		0.002376	59.1	5	30.54	124				16	0.44
48	0.04	0.024	0.605	9.2	9912	267	0.080305	0.080305	0.000098	9912	0.080305
8	16	0.87	293.3	-2.2	110	-171	-0.000895	-0.000895	-0.000063	426773	0.005117
	0	14.754	675.7	1	-258	13895	-0.002089	-0.002089	126.92	776	0.000716
		0.002377	58.9	4.8	39.82	110				20	0.62

RUN POINT	V/OR VKTS ALFS,U	MTUN QPSF BARO RHO	MTIP RPM OMEG*R TTEMPF	THETA A1 B1 CONING	LIFTH,C DRAGH,C SIDEH,C SKANGLE	PITCHH,S ROLLH,S TORQ,C HFORCE	CLRH/S CXRH/S CYRH/S	CLRHS/S CXRHS/S CYRHS/S	CMYHS/S CMXHS/S FE	THRUST POW HP VD	CTH/S CP/S CPO/S L/DR
48	0.05	0.03	0.606	8.8	9901	161	0.079955	0.079955	0.000059	9901	0.079955
9	20.1	1.37	293.8	-2.7	87	-67	-0.000699	-0.000699	-0.000025	409320	0.004883
	0	14.754	676.9	1.4	-284	13304	-0.002295	-0.002295	63.28	744	0.000511
		0.002376	58.9	4.8	48.34	87				21	0.81
48	0.061	0.037	0.604	8.3	9857	297	0.080292	0.080292	0.00011	9857	0.080292
10	24.3	1.99	292.5	-3	107	-280	-0.000872	-0.000872	-0.000104	385459	0.004659
	0	14.754	673.9	1.5	-342	12584	-0.002788	-0.002788	53.75	701	0.000743
		0.002377	58.7	4.9	55.99	107				33	1.03
48	0.071	0.043	0.605	7.7	9835	343	0.079774	0.079774	0.000127	9835	0.079774
11	28.6	2.77	293.1	-2.9	110	-182	-0.000892	-0.000892	-0.000067	357051	0.004289
	0	14.754	675.3	1.6	-317	11633	-0.002572	-0.002572	39.7	649	0.001023
		0.002377	58.5	4.9	62.59	110				42	1.31
48	0.091	0.055	0.607	7	9896	301	0.079953	0.079953	0.000111	9896	0.079953
12	36.5	4.5	293.7	-2.7	74	-213	-0.000599	-0.000599	-0.000078	313179	0.00374
	0	14.753	676.6	2.1	-297	10183	-0.0024	-0.0024	16.48	569	0.001165
		0.002377	58.3	5	71.11	74				48	1.92
48	0.1	0.061	0.606	6.7	9861	302	0.079907	0.079907	0.000111	9861	0.079907
13	40	5.42	293.3	-2.7	64	-187	-0.000516	-0.000516	-0.000069	292201	0.003504
	0	14.753	675.7	2.2	-277	9514	-0.002248	-0.002248	11.74	531	0.001167
		0.002376	58.3	5	73.96	64				53	2.25
48	0.124	0.075	0.604	6.2	9808	275	0.080033	0.080033	0.000102	9808	0.080033
14	49.6	8.31	292.4	-2.3	47	-117	-0.000382	-0.000354	-0.000044	254463	0.003082
	0.02	14.753	673.6	2.7	-235	8310	-0.001919	-0.001919	5.63	463	0.001201
		0.002374	58.3	5	79.23	43				75	3.18

RUN POINT	V/OR VKTS ALFS,U	MTUN QPSF BARO RHO	MTIP RPM OMEG*R TTEMPF	THETA A1 B1 CONING	LIFTH,C DRAGH,C SIDEH,C SKANGLE	PITCHH,S ROLLH,S TORQ,C HFORCE	CLRH/S CXRH/S CYRH/S	CLRHS/S CXRHS/S CYRHS/S	CMYHS/S CMXHS/S FE	THRUST POW HP VD	CTH/S CP/S CPO/S L/DR
48	0.15	0.091	0.606	5.9	9835	221	0.079852	0.079852	0.000081	9835	0.079852
15	59.9	12.12	293.3	-2	35	-218	-0.000285	-0.000285	-0.000081	230373	0.002768
	0	14.753	675.7	3.1	-233	7501	-0.001896	-0.001896	2.89	419	0.001217
		0.002372	58.3	5.1	82.47	35				111	4.25
48	0.2	0.121	0.606	5.6	9799	329	0.079954	0.079954	0.000122	9799	0.079954
16	79.9	21.54	292.9	-1.6	60	-226	-0.000492	-0.000492	-0.000084	195903	0.002369
	0	14.753	674.8	3.8	-222	6387	-0.00181	-0.00181	2.8	356	0.001272
		0.002366	58.1	5.1	85.73	60				263	6.48
48	0.251	0.152	0.604	5.8	9698	197	0.079969	0.079969	0.000074	9698	0.079969
17	100.1	33.69	291.8	-1.2	49	-274	-0.000403	-0.000403	-0.000103	183104	0.002246
	0	14.754	672.3	4.8	-229	5992	-0.001886	-0.001886	1.45	333	0.001396
		0.002359	57.9	5.1	87.29	49				473	8.56
48	0.251	0.152	0.605	5.8	9699	205	0.07979	0.07979	0.000077	9699	0.07979
18	100.1	33.69	292.2	-1.2	50	-259	-0.000415	-0.000415	-0.000097	182881	0.002235
	0	14.754	673.2	4.8	-232	5977	-0.00191	-0.00191	1.5	333	0.001391
		0.002358	58.1	5.1	87.29	50				475	8.57
48	0.2	0.121	0.605	5.7	9789	152	0.080118	0.080118	0.000056	9789	0.080118
19	79.9	21.51	292.4	-1.6	39	-168	-0.000318	-0.000318	-0.000063	200093	0.002431
	0	14.754	673.6	4	-229	6535	-0.001874	-0.001874	1.8	364	0.001295
		0.002367	57.9	5.1	85.73	39				245	6.43
48	0.151	0.091	0.606	5.9	9870	154	0.080085	0.080085	0.000057	9870	0.080085
20	60.4	12.31	293.3	-2	33	-184	-0.000268	-0.000268	-0.000068	230912	0.002773
	0	14.755	675.7	3.2	-254	7518	-0.002065	-0.002065	2.68	420	0.001222
		0.002373	58	5.1	82.56	33				112	4.29

RUN POINT	V/OR VKTS ALFS,U	MTUN QPSF BARO RHO	MTIP RPM OMEG*R TTEMPF	THETA A1 B1 CONING	LIFTH,C DRAGH,C SIDEH,C SKANGLE	PITCHH,S ROLLH,S TORQ,C HFORCE	CLRH/S CXRH/S CYRH/S	CLRHS/S CXRHS/S CYRHS/S	CMYHS/S CMXHS/S FE	THRUST POW HP VD	CTH/S CP/S CPO/S L/DR
48	0.125	0.076	0.605	6.2	9803	161	0.07986	0.07986	0.000059	9803	0.07986
21	50.1	8.5	292.5	-2.3	34	-30	-0.000279	-0.000279	-0.000011	254466	0.003076
	0	14.755	673.9	2.9	-247	8308	-0.002013	-0.002013	4.03	463	0.00121
		0.002377	57.8	5	79.44	34				71	3.22
48	0.102	0.062	0.605	6.7	9826	108	0.079959	0.079959	0.000004	9826	0.079959
22	40.7	5.62	292.5	-2.6	35	-124	-0.000285	-0.000285	-0.000046	291391	0.003519
	0	14.756	673.9	2.5	-287	9513	-0.002337	-0.002337	6.24	530	0.001203
		0.002379	57.7	5	74.51	35				43	2.3
48	0.102	0.062	0.605	6.7	9828	235	0.079748	0.079748	0.000087	9828	0.079748
23	40.7	5.61	292.9	-2.6	55	-115	-0.000449	-0.000449	-0.000043	289853	0.003485
	0	14.757	674.8	2.4	-281	9450	-0.002283	-0.002283	9.86	527	0.001193
		0.00238	57.7	5	74.48	55				51	2.3
48	0.091	0.055	0.605	7	9808	75	0.079583	0.079583	0.000028	9808	0.079583
24	36.5	4.51	292.8	-2.7	37	-113	-0.000297	-0.000297	-0.000042	311160	0.003743
	0	14.757	674.6	2.3	-290	10148	-0.002355	-0.002355	8.13	566	0.001174
		0.002381	57.5	4.9	71.29	37				34	1.93
48	0.071	0.043	0.605	7.8	9856	256	0.08	0.08	0.000094	9856	0.08
25	28.2	2.71	292.6	-2.9	95	-192	-0.000772	-0.000772	-0.000071	361337	0.004351
	0	14.758	674.1	1.6	-329	11793	-0.002667	-0.002667	35.13	657	0.00102
		0.002384	57.3	4.9	62.12	95				37	1.28
48	0.061	0.037	0.606	8.2	9828	158	0.07937	0.07937	0.000058	9828	0.07937
26	24.4	2.02	293.3	-2.9	83	-244	-0.000672	-0.000672	-0.000089	384645	0.004597
	0	14.759	675.7	1.5	-342	12523	-0.002765	-0.002765	41.13	699	0.000772
		0.002384	57.3	4.9	56.36	83				27	1.04

RUN POINT	V/OR VKTS ALFS,U	MTUN QPSF BARO RHO	MTIP RPM OMEG*R TTEMPF	THETA A1 B1 CONING	LIFTH,C DRAGH,C SIDEH,C SKANGLE	PITCHH,S ROLLH,S TORQ,C HFORCE	CLRHS/S CXRHS/S CYRHS/S	CLRHS/S CXRHS/S CYRHS/S	CMYHS/S CMXHS/S FE	THRUST POW HP VD	CTH/S CP/S CPO/S L/DR
48	0.051	0.031	0.607	8.6	9878	133	0.079627	0.079627	0.000049	9878	0.079627
27	20.4	1.42	293.5	-2.8	77	-234	-0.000624	-0.000624	-0.000086	406372	0.004844
	0	14.758	676.2	1.4	-327	13222	-0.002637	-0.002637	54.54	739	0.000499
		0.002386	57.1	4.9	49.12	77				20	0.83
48	0.041	0.025	0.606	9	9812	248	0.0794	0.0794	0.000091	9812	0.0794
28	16.4	0.91	292.9	-2.1	96	-193	-0.000778	-0.000778	-0.000071	421620	0.005056
	0	14.759	674.8	1	-273	13746	-0.002209	-0.002209	105.72	767	0.000729
		0.002386	57.1	4.8	40.8	96				18	0.64
48	0.031	0.019	0.604	9.4	9918	232	0.080542	0.080542	0.000085	9918	0.080542
29	12.4	0.52	292.3	-1.6	89	-266	-0.000722	-0.000722	-0.000098	454590	0.005482
	0	14.76	673.4	0.7	-235	14851	-0.001911	-0.001911	171.05	827	0.001061
		0.002387	56.9	4.9	31.44	89				12	0.45
48	0.021	0.013	0.605	9.8	9899	131	0.08018	0.08018	0.000048	9899	0.08018
30	8.4	0.24	292.6	-1.2	53	-272	-0.000433	-0.000433	-0.0001	501694	0.006028
	0	14.76	674.1	0.6	-177	16373	-0.001433	-0.001433	222.6	912	0.001638
		0.002389	56.7	4.8	21.72	53				5	0.28
48	0.012	0.007	0.606	10.2	10060	166	0.0812	0.0812	0.000061	10060	0.0812
31	4.8	0.08	293.1	0.1	53	14	-0.000432	-0.000432	0.000005	546297	0.00653
	0	14.76	675.3	0.3	-14	17799	-0.000115	-0.000115	668.74	993	0.002055
		0.002389	56.7	4.8	12.55	53				3	0.15
39	0.25	0.151	0.605	3.9	9689	114	0.079612	0.079999	0.000043	9736	0.079999
6	99.3	33.37	291.4	-1.1	963	-186	-0.00791	-0.000941	-0.000069	27406	0.000335
	5	14.766	671.3	3.9	-255	898	-0.002096	-0.002096	28.84	50	0.001362
		0.002374	55	5.2	92.24	115				1402	8.6

RUN POINT	V/OR VKTS ALFS,U	MTUN QPSF BARO RHO	MTIP RPM OMEG*R TTEMPF	THETA A1 B1 CONING	LIFTH,C DRAGH,C SIDEH,C SKANGLE	PITCHH,S ROLLH,S TORQ,C HFORCE	CLRH/S CXRH/S CYRH/S	CLRHS/S CXRHS/S CYRHS/S	CMYHS/S CMXHS/S FE	THRUST POW HP VD	CTH/S CP/S CPO/S L/DR
39	0.223	0.135	0.607	4	9804	-82	0.07988	0.080227	-0.000031	9847	0.080227
7	89	26.81	292.4	-1.3	916	-86	-0.007466	-0.000476	-0.000032	53568	0.000648
	5	14.766	673.6	3.8	-237	1749	-0.001933	-0.001933	34.18	97	0.001242
		0.002378	55.1	5.2	91.53	58				1129	7.7
39	0.198	0.12	0.606	4.1	9834	107	0.08022	0.080578	0.00004	9878	0.080578
8	78.9	21.14	292	-1.5	932	-120	-0.007605	-0.000584	-0.000045	70405	0.000854
	5	14.765	672.7	3.3	-238	2302	-0.001938	-0.001938	44.1	128	0.001145
		0.002382	55.1	5.2	90.58	72				957	6.73
39	0.174	0.105	0.606	4.2	9866	91	0.080262	0.080605	0.000034	9908	0.080605
9	69.3	16.3	292.2	-1.7	915	-77	-0.007441	-0.000418	-0.000029	95800	0.001158
	5	14.765	673.2	2.9	-233	3131	-0.001895	-0.001895	56.12	174	0.001063
		0.002385	55.1	5.2	89.24	51				784	5.69
39	0.151	0.091	0.605	4.5	9848	167	0.080142	0.080486	0.000062	9890	0.080486
10	60.1	12.26	292	-1.9	914	-42	-0.007437	-0.000424	-0.000015	122920	0.001487
	5	14.764	672.7	2.6	-228	4020	-0.001858	-0.001858	74.52	223	0.001013
		0.002387	55.1	5.1	87.37	52				651	4.63
39	0.124	0.075	0.607	4.9	9847	131	0.07957	0.079896	0.000048	9887	0.079896
11	49.7	8.39	292.9	-2.4	893	-116	-0.007217	-0.000255	-0.000043	166068	0.001989
	5	14.764	674.8	2.4	-256	5414	-0.002069	-0.002069	106.4	302	0.000979
		0.002389	55.2	5.1	83.92	32				505	3.43
39	0.101	0.061	0.606	5.7	9872	193	0.07991	0.080237	0.000071	9912	0.080237
12	40.3	5.53	292.5	-2.8	894	-44	-0.007237	-0.000245	-0.000016	217377	0.002611
	5	14.764	673.9	2.2	-278	7097	-0.002247	-0.002247	161.56	395	0.000976
		0.002392	55.1	5	78.51	30				395	2.41

RUN POINT	V/OR VKTS ALFS,U	MTUN QPSF BARO RHO	MTIP RPM OMEG*R TTEMPF	THETA A1 B1 CONING	LIFTH,C DRAGH,C SIDEH,C SKANGLE	PITCHH,S ROLLH,S TORQ,C HFORCE	CLRH/S CXRH/S CYRH/S	CLRHS/S CXRHS/S CYRHS/S	CMYHS/S CMXHS/S FE	THRUST POW HP VD	CTH/S CP/S CPO/S L/DR
39	0.091	0.055	0.605	6.1	9860	177	0.080179	0.080503	0.000066	9900	0.080503
13	36.3	4.48	291.8	-3.1	888	-120	-0.007222	-0.000207	-0.000044	243510	0.002946
	5	14.763	672.3	2.1	-307	7969	-0.002494	-0.002494	198.31	443	0.000961
		0.002392	55.1	5	75.08	25				349	2.03
39	0.081	0.049	0.606	6.6	9980	243	0.080641	0.080979	0.000089	10022	0.080979
14	32.3	3.56	292.7	-3.1	917	-8	-0.007405	-0.000349	-0.000003	279360	0.003347
	5	14.763	674.3	2	-312	9114	-0.002524	-0.002524	257.67	508	0.000938
		0.002393	55.1	5	70.57	43				313	1.65
39	0.071	0.043	0.605	7.1	9858	161	0.080016	0.080346	0.000059	9899	0.080346
15	28.3	2.74	292	-3.4	898	-71	-0.007286	-0.000285	-0.000026	308633	0.003724
	5	14.763	672.7	1.9	-348	10093	-0.002826	-0.002826	327.85	561	0.000874
		0.002394	55.1	5	65.43	35				270	1.34
39	0.041	0.025	0.604	9.1	10025	316	0.081493	0.081872	0.000117	10072	0.081872
16	16.2	0.9	291.7	-2.7	973	-60	-0.007908	-0.000776	-0.000022	411712	0.00498
	5	14.763	672	1	-333	13478	-0.002709	-0.002709	1080.94	749	0.00045
		0.002395	55.1	5	41.33	95				161	0.63
39	0.03	0.018	0.608	9.3	9981	334	0.080194	0.080573	0.000122	10028	0.080573
17	12	0.49	293.4	-1.9	977	-143	-0.00785	-0.000831	-0.000052	440182	0.005232
	5	14.762	675.9	0.7	-263	14327	-0.002114	-0.002114	1994.02	800	0.000809
		0.002395	55.1	4.9	31.05	103				119	0.44
39	0.021	0.012	0.605	9.6	9856	197	0.079837	0.08019	0.000073	9900	0.08019
18	8.2	0.23	292.2	-1.5	930	-179	-0.007531	-0.000545	-0.000066	479444	0.005769
	5	14.762	673.2	0.6	-206	15669	-0.001666	-0.001666	4042.52	872	0.001377
		0.002395	55.1	4.8	21.55	67				78	0.28

RUN POINT	V/OR VKTS ALFS,U	MTUN QPSF BARO RHO	MTIP RPM OMEG*R TTEMPF	THETA A1 B1 CONING	LIFTH,C DRAGH,C SIDEH,C SKANGLE	PITCHH,S ROLLH,S TORQ,C HFORCE	CLRHS/S CXRH/S CYRH/S	CLRHS/S CXRHS/S CYRHS/S	CMYHS/S CMXHS/S FE	THRUST POW HP VD	CTH/S CP/S CPO/S L/DR
39	0.011	0.006	0.606	10.3	10004	45	0.080809	0.08113	0.000016	10044	0.08113
19	4.2	0.06	292.6	-0.3	893	-87	-0.007212	-0.000142	-0.000032	545365	0.006535
	5	14.762	674.1	0.6	-75	17799	-0.00061	-0.00061	14880.97	992	0.002066
		0.002395	55.1	4.9	10.94	18				38	0.13
39	0.011	0.006	0.606	10.3	10018	-126	0.081071	0.081376	-0.000046	10056	0.081376
20	4.2	0.06	292.3	-0.3	870	-134	-0.007043	0.00005	-0.000049	548310	0.006589
	5	14.762	673.4	0.6	-73	17913	-0.000591	-0.000591	14504.61	997	0.0021
		0.002396	55	4.9	10.93	-6				37	0.13
41	0.252	0.152	0.605	2.4	10006	104	0.082197	0.083611	0.000039	10178	0.083611
5	100.1	33.86	291.6	-0.8	1866	-17	-0.015332	-0.000826	-0.000006	-106268	-0.001299
	10	14.752	671.8	3.6	-283	-3480	-0.002322	-0.002322	55.12	-193	0.001553
		0.002371	55.2	5.6	97.17	101				2246	8.09
41	0.23	0.139	0.606	2.4	9815	37	0.080264	0.081639	0.000014	9983	0.081639
6	91.6	28.37	292	-1	1828	4	-0.014945	-0.000781	0.000002	-79467	-0.000966
	10	14.752	672.7	3.4	-259	-2599	-0.002118	-0.002118	64.43	-144	0.001418
		0.002376	55.1	5.4	96.68	95				2000	7.47
41	0.2	0.122	0.608	2.5	9655	84	0.078283	0.079632	0.000031	9821	0.079632
7	80.1	21.75	293	-1.3	1803	-39	-0.014621	-0.000805	-0.000014	-42234	-0.000507
	10	14.753	675	2.9	-240	-1376	-0.001946	-0.001946	82.92	-77	0.001277
		0.00238	55.2	5.3	95.72	99				1696	6.48
41	0.179	0.108	0.605	2.8	9676	119	0.079088	0.080441	0.000044	9841	0.080441
8	71.1	17.17	291.6	-1.5	1800	32	-0.01471	-0.000753	0.000012	-10070	-0.000123
	10	14.753	671.8	2.6	-215	-330	-0.001755	-0.001755	104.81	-18	0.001197
		0.002383	55.1	5.3	94.54	92				1462	5.64

RUN POINT	V/OR VKTS ALFS,U	MTUN QPSF BARO RHO	MTIP RPM OMEG*R TTEMPF	THETA A1 B1 CONING	LIFTH,C DRAGH,C SIDEH,C SKANGLE	PITCHH,S ROLLH,S TORQ,C HFORCE	CLRH/S CXRH/S CYRH/S	CLRHS/S CXRHS/S CYRHS/S	CMYHS/S CMXHS/S FE	THRUST POW HP VD	CTH/S CP/S CPO/S L/DR
41	0.151	0.091	0.607	3.3	9808	63	0.079405	0.080728	0.000023	9971	0.080728
9	60.2	12.33	292.8	-1.7	1799	-4	-0.014564	-0.000555	-0.000002	36379	0.000437
	10	14.753	674.6	2.2	-210	1186	-0.001697	-0.001697	145.85	66	0.001067
		0.002387	55.1	5.3	92.26	69				1188	4.55
41	0.125	0.076	0.605	3.8	9745	120	0.079292	0.08061	0.000044	9907	0.08061
10	49.8	8.46	291.9	-2.1	1785	-86	-0.014524	-0.000535	-0.000032	81069	0.000981
	10	14.754	672.5	1.8	-215	2652	-0.001748	-0.001748	211.11	147	0.000918
		0.002389	55.1	5.2	88.73	66				959	3.55
41	0.101	0.061	0.607	4.6	9798	145	0.079113	0.080406	0.000053	9959	0.080406
11	40.3	5.52	292.9	-2.7	1780	-34	-0.014369	-0.000413	-0.000012	144995	0.001735
	10	14.755	674.8	1.8	-231	4727	-0.001864	-0.001864	322.18	264	0.000858
		0.002391	55.1	5.1	82.77	51				755	2.5
41	0.091	0.055	0.605	5.1	9797	230	0.07962	0.08092	0.000085	9957	0.08092
12	36.4	4.52	291.9	-3.1	1778	-67	-0.014453	-0.000407	-0.000025	177063	0.00214
	10	14.756	672.5	1.8	-260	5792	-0.00211	-0.00211	393.49	322	0.000867
		0.002392	55.1	5.1	79.21	50				678	2.1
41	0.081	0.049	0.607	5.7	9812	316	0.079014	0.080306	0.000116	9972	0.080306
13	32.3	3.56	293.2	-3.3	1782	-49	-0.014352	-0.000413	-0.000018	217333	0.002591
	10	14.755	675.5	1.8	-284	7078	-0.002285	-0.002285	501.03	395	0.000857
		0.002393	55.1	5.1	74.29	51				598	1.7
41	0.041	0.025	0.604	8.7	9755	176	0.079246	0.080581	0.000065	9919	0.080581
14	16.2	0.9	291.8	-3.3	1800	-151	-0.01462	-0.000637	-0.000056	391102	0.004726
	10	14.756	672.3	1.1	-378	12799	-0.003068	-0.003068	1999.67	711	0.000302
		0.002395	55.1	5	42.59	78				300	0.61

RUN POINT	V/OR VKTS ALFS,U	MTUN QPSF BARO RHO	MTIP RPM OMEG*R TTEMPF	THETA A1 B1 CONING	LIFTH,C DRAGH,C SIDEH,C SKANGLE	PITCHH,S ROLLH,S TORQ,C HFORCE	CLRH/S CXRH/S CYRH/S	CLRHS/S CXRHS/S CYRHS/S	CMYHS/S CMXHS/S FE	THRUST POW HP VD	CTH/S CP/S CPO/S L/DR
41	0.029	0.018	0.605	9.2	9721	102	0.0789	0.080226	0.000038	9884	0.080226
15	11.6	0.46	291.9	-2.1	1792	-162	-0.014543	-0.000621	-0.00006	422448	0.005099
	10	14.757	672.5	0.9	-284	13820	-0.002305	-0.002305	3895.2	768	0.000704
		0.002395	55.1	4.9	30.71	77				214	0.42
41	0.019	0.011	0.609	9.7	9964	90	0.079762	0.081095	0.000033	10130	0.081095
16	7.5	0.19	293.9	-1.6	1830	-176	-0.014652	-0.000579	-0.000064	492878	0.005827
	10	14.758	677.1	0.7	-217	16014	-0.001735	-0.001735	9633.53	896	0.001361
		0.002396	55.1	4.9	19.44	72				137	0.24
41	0	0	0.606	10	9962	213	0.080442	0.081806	0.000078	10131	0.081806
17	0	0	292.6	-0.8	1844	325	-0.014889	-0.000695	0.000119	518136	0.006207
	10	14.759	674.1	0.4	-67	16910	-0.000545	-0.000545	0	942	0.001682
		0.002396	55.1	4.9	0.04	86				0	0
41	0.01	0.006	0.606	10	9578	-61	0.07735	0.078567	-0.000023	9729	0.078567
18	4.2	0.06	292.6	-0.5	1706	-118	-0.013777	-0.000136	-0.000043	519108	0.006219
	10	14.759	674.1	0.6	-94	16942	-0.000757	-0.000757	28433.23	944	0.00196
		0.002396	55.1	4.7	11.08	17				74	0.13
31	0.251	0.152	0.606	2.2	9903	24	0.081342	0.082746	0.000009	10074	0.082746
17	100.1	33.61	292.6	-0.9	1851	-48	-0.015201	-0.00083	-0.000018	-107046	-0.001304
	10.01	14.716	674.1	3.6	-305	-3494	-0.002503	-0.002503	55.07	-195	0.001517
		0.002356	57.1	5.6	97.19	101				2249	8.14
31	0.201	0.121	0.605	2.8	9995	178	0.082032	0.083472	0.000067	10170	0.083472
18	80	21.56	292.2	-1.3	1885	-29	-0.01547	-0.000976	-0.000011	-47442	-0.000578
	10.01	14.717	673.2	2.8	-256	-1550	-0.002101	-0.002101	87.42	-86	0.001271
		0.002364	57.1	5.6	95.54	119				1699	6.52

RUN POINT	V/OR VKTS ALFS,U	MTUN QPSF BARO RHO	MTIP RPM OMEG*R TTEMPF	THETA A1 B1 CONING	LIFTH,C DRAGH,C SIDEH,C SKANGLE	PITCHH,S ROLLH,S TORQ,C HFORCE	CLRHS/S CXRHS/S CYRHS/S	CLRHS/S CXRHS/S CYRHS/S	CMYHS/S CMXHS/S FE	THRUST POW HP VD	CTH/S CP/S CPO/S L/DR
31	0.151	0.092	0.606	3.5	10167	153	0.08283	0.084241	0.000057	10341	0.084241
19	60.5	12.38	292.8	-1.8	1887	-25	-0.01537	-0.000739	-0.000009	33791	0.000408
	10.01	14.716	674.6	2.2	-222	1102	-0.00181	-0.00181	152.45	61	0.001041
		0.002372	56.7	5.5	92	91				1203	4.59
31	0.125	0.076	0.605	4.1	10133	118	0.082745	0.08413	0.000044	10303	0.08413
20	49.9	8.41	292.3	-2.2	1863	-125	-0.015215	-0.000601	-0.000046	84469	0.001024
	10.01	14.715	673.4	1.9	-230	2760	-0.001876	-0.001876	221.43	154	0.000878
		0.002374	56.7	5.5	88.23	74				961	3.53
31	0.1	0.061	0.607	5	10218	154	0.082621	0.083976	0.000057	10386	0.083976
21	40.1	5.45	293.5	-2.8	1859	-39	-0.01503	-0.00044	-0.000014	158302	0.001893
	10.01	14.715	676.2	1.9	-246	5151	-0.001986	-0.001986	340.95	288	0.000849
		0.002378	56.3	5.4	81.85	54				752	2.43
31	0.08	0.048	0.605	6	10179	228	0.082869	0.084211	0.000084	10344	0.084211
22	32	3.46	292.5	-3.3	1839	-72	-0.014974	-0.000342	-0.000027	229408	0.002771
	10.01	14.714	673.9	1.9	-304	7490	-0.002472	-0.002472	530.88	417	0.000765
		0.002378	56.5	5.3	72.92	42				589	1.67
37	0.252	0.152	0.604	11.9	11846	340	0.098209	0.09972	0.000128	12029	0.09972
19	100.4	33.65	291.9	-2.2	-2086	-304	0.017297	-0.00002	-0.000114	641045	0.007903
	-10	14.708	672.5	6.9	-334	20971	-0.002765	-0.002765	-62.01	1166	0.002114
		0.002345	58.9	5.7	76.76	2				-1429	6.98
37	0.2	0.121	0.607	11	12152	222	0.099149	0.100693	0.000082	12341	0.100693
20	80.1	21.49	293.7	-2.3	-2153	-407	0.017568	0.000084	-0.000151	595494	0.007181
	-10	14.708	676.6	5.5	-363	19362	-0.002963	-0.002963	-100.2	1083	0.001831
		0.002354	58.8	5.8	74.87	-10				-1250	5.39

RUN POINT	V/OR VKTS ALFS,U	MTUN QPSF BARO RHO	MTIP RPM OMEG*R TTEMPF	THETA A1 B1 CONING	LIFTH,C DRAGH,C SIDEH,C SKANGLE	PITCHH,S ROLLH,S TORQ,C HFORCE	CLRH/S CXRH/S CYRH/S	CLRHS/S CXRHS/S CYRHS/S	CMYHS/S CMXHS/S FE	THRUST POW HP VD	CTH/S CP/S CPO/S L/DR
37	0.151	0.091	0.605	10.5	12100	235	0.099129	0.100604	0.000087	12280	0.100604
21	60.2	12.17	292.7	-2.4	-2096	-222	0.017169	-0.000306	-0.000083	550448	0.006687
	-10	14.707	674.3	4.1	-350	17958	-0.002868	-0.002868	-172.2	1001	0.001661
		0.00236	58.7	5.9	71.31	37				-969	3.64
37	0.125	0.076	0.604	10.4	12134	251	0.099324	0.100762	0.000093	12310	0.100762
22	49.9	8.39	292.6	-2.4	-2074	-232	0.016973	-0.000533	-0.000086	549866	0.006677
	-10	14.708	674.1	3.4	-371	17945	-0.00304	-0.00304	-247.02	1000	0.001604
		0.002364	58.5	5.9	67.87	65				-811	2.73
37	0.101	0.061	0.604	10.6	12090	259	0.098888	0.100291	0.000096	12262	0.100291
23	40.3	5.47	292.6	-2.5	-2046	-258	0.016732	-0.000693	-0.000096	559742	0.006792
	-10	14.707	674.1	2.8	-388	18268	-0.003172	-0.003172	-373.83	1018	0.001479
		0.002366	58.5	5.9	62.79	85				-660	1.96
37	0.091	0.055	0.604	10.7	12064	198	0.09887	0.100286	0.000074	12236	0.100286
24	36.4	4.48	292.2	-2.5	-2050	-198	0.016803	-0.000621	-0.000074	566562	0.006898
	-10	14.707	673.2	2.7	-373	18516	-0.003058	-0.003058	-457.77	1030	0.001361
		0.002367	58.3	5.9	60	76				-603	1.68
37	0.081	0.049	0.608	10.8	12171	210	0.098391	0.099795	0.000077	12345	0.099795
25	32.4	3.55	294.1	-2.5	-2065	-222	0.016696	-0.000643	-0.000082	586173	0.006994
	-10	14.708	677.6	2.4	-379	19033	-0.003067	-0.003067	-582.32	1066	0.001162
		0.002369	58.1	5.8	56.29	79				-538	1.41
37	0.06	0.036	0.605	11.3	12140	276	0.099036	0.100432	0.000102	12311	0.100432
26	24	1.95	292.7	-2.5	-2048	-309	0.016709	-0.000743	-0.000115	606923	0.007343
	-10	14.708	674.3	1.7	-378	19801	-0.003081	-0.003081	-1050.22	1103	0.001187
		0.00237	58.1	5.9	46.42	91				-400	0.94

RUN POINT	V/OR VKTS ALFS,U	MTUN QPSF BARO RHO	MTIP RPM OMEG*R TTEMPF	THETA A1 B1 CONING	LIFTH,C DRAGH,C SIDEH,C SKANGLE	PITCHH,S ROLLH,S TORQ,C HFORCE	CLRHS/S CXRHS/S CYRHS/S	CLRHS/S CXRHS/S CYRHS/S	CMYHS/S CMXHS/S FE	THRUST POW HP VD	CTH/S CP/S CPO/S L/DR
37	0.05	0.03	0.604	11.5	12125	198	0.099082	0.100496	0.000074	12298	0.100496
27	20.1	1.37	292.4	-2.2	-2058	-228	0.016814	-0.000646	-0.000085	616749	0.007482
	-10	14.708	673.6	1.6	-336	20142	-0.002744	-0.002744	-1505.08	1121	0.00132
		0.002371	58	5.8	40.57	79				-338	0.75
37	0.041	0.025	0.605	11.6	12124	243	0.098616	0.100026	0.00009	12298	0.100026
28	16.3	0.9	293.1	-1.9	-2059	-252	0.016747	-0.000632	-0.000093	635091	0.00765
	-10	14.708	675.3	1.3	-300	20691	-0.002443	-0.002443	-2287.74	1155	0.001532
		0.002371	58.1	5.8	34.12	78				-275	0.58
37	0.03	0.018	0.604	11.9	12120	258	0.099063	0.100486	0.000096	12294	0.100486
29	11.8	0.47	292.4	-1.2	-2063	-219	0.016863	-0.000595	-0.000081	671089	0.008143
	-10	14.709	673.6	1	-226	21917	-0.001846	-0.001846	-4389.71	1220	0.001982
		0.00237	58.2	5.8	25.57	73				-200	0.38
37	0.02	0.012	0.605	12.2	12180	228	0.099144	0.10059	0.000084	12358	0.10059
30	7.9	0.21	293	-1	-2089	8	0.017004	-0.00047	0.000003	719625	0.008678
	-10	14.709	675	0.8	-148	23454	-0.001205	-0.001205	-9947.73	1308	0.002508
		0.00237	58.2	5.7	17.49	58				-135	0.23
37	0.013	0.008	0.606	12.4	12163	217	0.098759	0.100229	0.00008	12344	0.100229
31	5.2	0.09	293.3	0	-2107	23	0.017104	-0.000305	0.000008	744972	0.008952
	-10	14.709	675.7	0.5	-25	24255	-0.000201	-0.000201	-23405.73	1354	0.002815
		0.002372	58	5.7	11.62	38				-89	0.15
33	0.251	0.152	0.606	8.8	12113	39	0.100112	0.100158	0.000015	12119	0.100158
5	100.1	33.54	292.1	-1.7	-372	-283	0.003076	-0.000419	-0.000106	328291	0.004032
	-2	14.658	673	6.2	-360	10732	-0.002976	-0.002976	-11.1	597	0.001767
		0.002349	56.5	6.1	84.62	51				25	7.71

RUN POINT	V/OR VKTS ALFS,U	MTUN QPSF BARO RHO	MTIP RPM OMEG*R TTEMPF	THETA A1 B1 CONING	LIFTH,C DRAGH,C SIDEH,C SKANGLE	PITCHH,S ROLLH,S TORQ,C HFORCE	CLRHS/S CXRHS/S CYRHS/S	CLRHS/S CXRHS/S CYRHS/S	CMYHS/S CMXHS/S FE	THRUST POW HP VD	CTH/S CP/S CPO/S L/DR
33 6	0.201 80.2 -2	0.122 21.58 14.658 0.002358	0.606 292.5 673.9 56.3	8.5 -2.2 5.1 6.1	12217 -403 -372 82.74	31 -364 10980 24	0.100315 0.003306 -0.003051	0.100369 -0.000197 -0.003051	0.000012 -0.000136 -18.65	12224 336326 612 -95	0.100369 0.004098 0.00156 5.86
33 7	0.15 60 -2	0.091 12.13 14.657 0.002363	0.607 293 675 56.5	8.6 -2.5 4.1 6.1	12287 -398 -367 78.77	60 -218 12042 31	0.100324 0.00325 -0.002995	0.100376 -0.000254 -0.002995	0.000022 -0.000081 -32.81	12293 369478 672 -125	0.100376 0.004469 0.001474 3.78
33 8	0.126 50.2 -2	0.076 8.48 14.657 0.002366	0.606 292.6 674.1 56.5	8.9 -2.7 3.5 6.1	12332 -370 -378 75.08	192 -130 13025 60	0.100869 0.003028 -0.00309	0.100913 -0.000494 -0.00309	0.000071 -0.000048 -43.68	12338 399096 726 -111	0.100913 0.004842 0.001432 2.84
33 9	0.107 42.5 -2	0.064 6.09 14.656 0.002369	0.605 292.1 673 56.1	9.2 -2.9 3.1 6	12170 -371 -403 70.91	129 -150 13914 54	0.099737 0.00304 -0.003305	0.099783 -0.000442 -0.003305	0.000048 -0.000056 -60.94	12175 425619 774 -105	0.099783 0.005183 0.001367 2.19
33 10	0.06 24 -2	0.036 1.95 14.655 0.002372	0.608 293.9 677.1 56	10.6 -2.9 1.6 5.9	12300 -289 -440 50.21	405 -172 17645 140	0.09944 0.002338 -0.003555	0.099461 -0.001134 -0.003555	0.000149 -0.000063 -148.26	12302 543059 987 -53	0.099461 0.006484 0.000418 0.94
33 11	0.05 20 -2	0.03 1.36 14.654 0.002375	0.607 292.9 674.8 55.5	11.1 -2.6 1.4 5.9	12299 -295 -408 43.35	368 -150 18529 134	0.099999 0.002401 -0.003315	0.100022 -0.00109 -0.003315	0.000136 -0.000055 -217.66	12302 568323 1033 -46	0.100022 0.006848 0.00073 0.74

RUN POINT	V/OR VKTS ALFS,U	MTUN QPSF BARO RHO	MTIP RPM OMEG*R TTEMPF	THETA A1 B1 CONING	LIFTH,C DRAGH,C SIDEH,C SKANGLE	PITCHH,S ROLLH,S TORQ,C HFORCE	CLRH/S CXRH/S CYRH/S	CLRHS/S CXRHS/S CYRHS/S	CMYHS/S CMXHS/S FE	THRUST POW HP VD	CTH/S CP/S CPO/S L/DR
33	0.04	0.024	0.604	11.4	12186	361	0.09998	0.100006	0.000135	12190	0.100006
12	16	0.87	291.5	-2.1	-303	-80	0.00249	-0.001001	-0.00003	586219	0.007162
	-2	14.654	671.6	1.1	-330	19204	-0.002706	-0.002706	-348.8	1066	0.001045
		0.002376	55.3	5.9	35.83	122				-39	0.57
33	0.031	0.018	0.604	11.7	12203	95	0.100113	0.100156	0.000036	12209	0.100156
13	12.2	0.5	291.5	-1.8	-365	-214	0.002995	-0.000501	-0.00008	629080	0.007685
	-2	14.654	671.6	1.1	-287	20608	-0.002356	-0.002356	-730.12	1144	0.001555
		0.002376	55.3	5.8	27.71	61				-36	0.4
33	0.02	0.012	0.606	12.2	12371	160	0.100802	0.100851	0.000059	12377	0.100851
14	8.1	0.22	292.5	-1.3	-387	-262	0.003153	-0.000367	-0.000097	702085	0.008489
	-2	14.653	673.9	0.9	-242	22921	-0.001975	-0.001975	-1758.78	1277	0.002295
		0.002376	55.3	5.8	18.55	45				-25	0.24
33	0	0	0.607	12.2	12180	146	0.098837	0.098874	0.000054	12185	0.098874
15	0	0	293	0.2	-346	478	0.002809	-0.000642	0.000176	697786	0.008388
	-2	14.653	675	-0.2	58	22742	0.000468	0.000468	0	1269	0.002376
		0.002378	55.1	5.8	0.04	79				0	0
35	0.251	0.152	0.606	8.8	12213	249	0.100094	0.100138	0.000093	12218	0.100138
20	99.6	33.71	291	-1.8	-367	-204	0.003009	-0.000486	-0.000076	331912	0.004057
	-2	14.751	670.4	6.2	-381	10892	-0.003125	-0.003125	-10.89	603	0.001809
		0.002387	52.1	6.2	84.61	59				31	7.6
35	0.224	0.136	0.606	8.7	12365	58	0.101038	0.101098	0.000022	12372	0.101098
21	89	27	291.1	-2	-428	-139	0.003495	-0.000033	-0.000051	344260	0.004195
	-2	14.751	670.6	5.9	-372	11293	-0.003038	-0.003038	-15.84	626	0.001707
		0.002392	51.9	6.2	83.73	4				-76	6.64

RUN POINT	V/OR VKTS ALFS,U	MTUN QPSF BARO RHO	MTIP RPM OMEG*R TTEMPF	THETA A1 B1 CONING	LIFTH,C DRAGH,C SIDEH,C SKANGLE	PITCHH,S ROLLH,S TORQ,C HFORCE	CLRH/S CXRH/S CYRH/S	CLRHS/S CXRHS/S CYRHS/S	CMYHS/S CMXHS/S FE	THRUST POW HP VD	CTH/S CP/S CPO/S L/DR
35	0.198	0.12	0.606	8.5	12291	86	0.100044	0.1001	0.000032	12298	0.1001
22	78.9	21.27	291.4	-2.2	-412	-127	0.003353	-0.000141	-0.000047	342636	0.004154
	-2	14.751	671.3	5.2	-364	11228	-0.002961	-0.002961	-19.36	623	0.001603
		0.002397	51.8	6.2	82.63	17				-102	5.69
35	0.174	0.105	0.605	8.5	12338	133	0.100705	0.100757	0.000049	12344	0.100757
23	69.1	16.33	290.8	-2.3	-398	-155	0.003249	-0.000267	-0.000058	352495	0.004294
	-2	14.751	670	4.6	-378	11575	-0.003088	-0.003088	-24.38	641	0.00155
		0.0024	51.8	6.2	81.03	33				-115	4.7
35	0.151	0.092	0.607	8.6	12371	192	0.100292	0.100339	0.000071	12377	0.100339
24	60.2	12.39	291.6	-2.5	-382	-150	0.003096	-0.000406	-0.000055	370867	0.004475
	-2	14.751	671.8	4	-391	12145	-0.003172	-0.003172	-30.83	674	0.001518
		0.002403	51.7	6.2	78.89	50				-115	3.78
35	0.125	0.076	0.607	9	12452	245	0.100625	0.100666	0.00009	12457	0.100666
25	49.7	8.47	291.9	-2.9	-364	-171	0.002941	-0.000573	-0.000063	408199	0.004905
	-2	14.751	672.5	3.4	-427	13354	-0.003452	-0.003452	-42.98	742	0.001503
		0.002406	51.7	6.2	74.95	71				-106	2.77
35	0.113	0.069	0.606	9	12205	212	0.098733	0.098773	0.000078	12210	0.098773
26	45.2	6.99	291.7	-2.9	-354	-86	0.00286	-0.000587	-0.000031	413822	0.004981
	-2	14.75	672	3.1	-404	13547	-0.003267	-0.003267	-50.59	752	0.001442
		0.002407	51.7	6.1	72.8	73				-101	2.4
35	0.06	0.036	0.603	10.8	12310	305	0.100595	0.10062	0.000113	12313	0.10062
27	23.9	1.96	290	-3	-301	-150	0.002463	-0.001049	-0.000056	546111	0.00668
	-2	14.749	668.1	1.6	-451	17983	-0.003689	-0.003689	-153.76	993	0.000507
		0.00241	51.6	6	50.3	128				-55	0.93

RUN POINT	V/OR VKTS ALFS,U	MTUN QPSF BARO RHO	MTIP RPM OMEG*R TTEMPF	THETA A1 B1 CONING	LIFTH,C DRAGH,C SIDEH,C SKANGLE	PITCHH,S ROLLH,S TORQ,C HFORCE	CLRHS/S CXRH/S CYRH/S	CLRHS/S CXRHS/S CYRHS/S	CMYHS/S CMXHS/S FE	THRUST POW HP VD	CTH/S CP/S CPO/S L/DR
35	0.05	0.03	0.605	11.2	12364	246	0.1003	0.100328	0.000091	12367	0.100328
28	20	1.38	291	-2.7	-314	-186	0.002546	-0.000956	-0.000069	576530	0.006976
	-2	14.75	670.4	1.5	-422	18919	-0.003424	-0.003424	-227.82	1048	0.000831
		0.002411	51.5	6	43.53	118				-49	0.74
35	0.042	0.025	0.604	11.5	12363	276	0.100686	0.100714	0.000102	12366	0.100714
29	16.7	0.96	290.4	-2.3	-314	-215	0.002555	-0.00096	-0.00008	599352	0.007296
	-2	14.75	669	1.2	-377	19709	-0.003069	-0.003069	-326.81	1090	0.001115
		0.002412	51.5	6	37.21	118				-41	0.59
35	0.031	0.019	0.607	11.8	12459	171	0.100207	0.100243	0.000062	12463	0.100243
30	12.2	0.51	292.2	-1.7	-344	-277	0.00277	-0.000729	-0.000101	660588	0.007893
	-2	14.75	673.2	1	-301	21588	-0.002421	-0.002421	-675.23	1201	0.001755
		0.002412	51.5	5.9	27.7	91				-33	0.39
39	0.249	0.151	0.606	5.9	12107	132	0.099303	0.099721	0.000049	12158	0.099721
21	99.2	33.28	291.7	-1.3	1113	-110	-0.00913	-0.00044	-0.000041	58692	0.000716
	5	14.76	672	5.1	-341	1921	-0.002798	-0.002798	33.44	107	0.001511
		0.002373	54.9	6.4	91.55	54				1246	8.27
39	0.223	0.135	0.607	6	12224	56	0.099675	0.10008	0.000021	12274	0.10008
22	89	26.8	292.3	-1.6	1104	-80	-0.008999	-0.000277	-0.00003	85525	0.001036
	5	14.76	673.4	4.8	-332	2794	-0.00271	-0.00271	41.18	155	0.001375
		0.002378	54.9	6.4	90.67	34				1043	7.31
39	0.198	0.12	0.605	6	12184	141	0.099661	0.100077	0.000052	12235	0.100077
23	78.7	21.04	291.6	-1.9	1116	-120	-0.009128	-0.000407	-0.000045	107673	0.001311
	5	14.76	671.8	4.1	-335	3526	-0.002737	-0.002737	53.04	196	0.00124
		0.002382	54.9	6.3	89.49	50				890	6.33

RUN POINT	V/OR VKTS ALFS,U	MTUN QPSF BARO RHO	MTIP RPM OMEG*R TTEMPF	THETA A1 B1 CONING	LIFTH,C DRAGH,C SIDEH,C SKANGLE	PITCHH,S ROLLH,S TORQ,C HFORCE	CLRH/S CXRH/S CYRH/S	CLRHS/S CXRHS/S CYRHS/S	CMYHS/S CMXHS/S FE	THRUST POW HP VD	CTH/S CP/S CPO/S L/DR
39	0.173	0.105	0.605	6.3	12277	112	0.100281	0.100694	0.000042	12328	0.100694
24	69	16.17	291.6	-2.1	1115	-21	-0.00911	-0.000335	-0.000008	144658	0.001759
	5	14.76	671.8	3.7	-318	4737	-0.002594	-0.002594	68.96	263	0.001169
		0.002385	54.9	6.3	87.78	41				741	5.21
39	0.151	0.091	0.606	6.5	12281	159	0.099789	0.100203	0.000059	12332	0.100203
25	60.1	12.28	292.2	-2.3	1120	4	-0.009101	-0.000369	0.000001	184558	0.002228
	5	14.761	673.2	3.3	-317	6031	-0.002577	-0.002577	91.19	336	0.001127
		0.002388	54.9	6.3	85.52	45				625	4.18
39	0.124	0.075	0.606	7.1	12284	193	0.099454	0.099859	0.000071	12334	0.099859
26	49.7	8.41	292.5	-2.9	1111	-66	-0.008992	-0.000029	-0.000024	247073	0.002969
	5	14.761	673.9	3.1	-363	8066	-0.002936	-0.002936	131.99	449	0.001116
		0.002391	54.7	6.2	81.33	36				494	3.03
39	0.101	0.061	0.605	8	12266	217	0.099539	0.09994	0.000008	12315	0.09994
27	40.2	5.5	292.1	-3.4	1102	-97	-0.008945	-0.000236	-0.000036	321183	0.003873
	5	14.761	673	2.8	-411	10500	-0.003331	-0.003331	200.3	584	0.001098
		0.002392	54.9	6.1	74.87	29				386	2.1
39	0.051	0.031	0.604	11.3	12788	265	0.104151	0.104631	0.000098	12847	0.104631
28	20.3	1.41	291.4	-3.5	1233	-112	-0.010045	-0.000929	-0.000041	569041	0.006903
	5	14.762	671.3	1.6	-510	18648	-0.004154	-0.004154	875.95	1035	0.000358
		0.002395	54.9	6.2	45.35	114				200	0.72
39	0.04	0.024	0.606	11.3	12414	197	0.100395	0.100854	0.000072	12471	0.100854
29	16	0.87	292.4	-2.6	1193	-58	-0.009645	-0.000858	-0.000022	577484	0.006933
	5	14.762	673.6	1.3	-395	18860	-0.003196	-0.003196	1370.78	1050	0.000739
		0.002396	54.9	5.9	36.82	106				156	0.55

RUN POINT	V/OR VKTS ALFS,U	MTUN QPSF BARO RHO	MTIP RPM OMEG*R TTEMPF	THETA A1 B1 CONING	LIFTH,C DRAGH,C SIDEH,C SKANGLE	PITCHH,S ROLLH,S TORQ,C HFORCE	CLRHS/S CXRH/S CYRH/S	CLRHS/S CXRHS/S CYRHS/S	CMYHS/S CMXHS/S FE	THRUST POW HP VD	CTH/S CP/S CPO/S L/DR
39	0.03	0.018	0.607	11.7	12387	161	0.099754	0.10021	0.000059	12443	0.10021
30	11.9	0.48	293	-1.9	1191	-181	-0.009588	-0.000858	-0.000066	624680	0.007453
	5	14.762	675	1.1	-320	20359	-0.002576	-0.002576	2480.47	1136	0.001318
		0.002396	54.9	5.9	27.67	107				115	0.38
39	0.02	0.012	0.606	12.1	12340	103	0.099715	0.100145	0.000038	12393	0.100145
31	8	0.22	292.5	-1.4	1150	-194	-0.009292	-0.000565	-0.000071	690615	0.008282
	5	14.761	673.9	0.9	-243	22547	-0.001968	-0.001968	5226.43	1256	0.002153
		0.002396	54.9	5.8	18.85	70				76	0.24
39	0.01	0.006	0.601	13	12635	313	0.103797	0.104272	0.000117	12693	0.104272
32	3.8	0.05	290.1	0.2	1215	222	-0.009983	-0.000899	0.000083	771790	0.009486
	5	14.761	668.3	0.5	-29	25405	-0.000236	-0.000236	24305.41	1403	0.002975
		0.002396	54.9	5.8	8.88	109				37	0.1
41	0.251	0.152	0.606	4.1	12088	219	0.098964	0.100608	0.000081	12289	0.100608
19	99.8	33.71	291.9	-1.1	2214	-84	-0.018127	-0.000667	-0.000031	-108527	-0.001321
	10	14.763	672.5	4.5	-359	-3550	-0.002942	-0.002942	65.69	-197	0.001759
		0.002375	54.9	6.6	96.56	81				2140	7.7
41	0.229	0.139	0.606	4.3	12125	153	0.098966	0.100617	0.000057	12327	0.100617
20	91.3	28.22	292.1	-1.3	2225	-59	-0.018161	-0.0007	-0.000022	-78906	-0.000957
	10	14.764	673	4.2	-348	-2580	-0.002837	-0.002837	78.84	-143	0.0016
		0.002379	54.9	6.6	95.86	86				1912	7.08
41	0.2	0.122	0.607	4.5	12101	85	0.098246	0.099893	0.000031	12304	0.099893
21	80	21.75	292.6	-1.6	2227	32	-0.018079	-0.000745	0.000012	-34537	-0.000416
	10	14.765	674.1	3.7	-309	-1127	-0.002507	-0.002507	102.4	-63	0.001406
		0.002383	54.9	6.5	94.62	92				1632	6.14

RUN POINT	V/OR VKTS ALFS,U	MTUN QPSF BARO RHO	MTIP RPM OMEG*R TTEMPF	THETA A1 B1 CONING	LIFTH,C DRAGH,C SIDEH,C SKANGLE	PITCHH,S ROLLH,S TORQ,C HFORCE	CLRH/S CXRH/S CYRH/S	CLRHS/S CXRHS/S CYRHS/S	CMYHS/S CMXHS/S FE	THRUST POW HP VD	CTH/S CP/S CPO/S L/DR
41	0.178	0.108	0.605	4.8	12059	161	0.098383	0.100064	0.00006	12265	0.100064
22	70.9	17.07	291.7	-1.9	2242	1	-0.018289	-0.000927	0	3559	0.000043
	10	14.765	672	3.2	-302	117	-0.00246	-0.00246	131.35	6	0.001264
		0.002386	54.9	6.5	93.13	114				1427	5.31
41	0.151	0.091	0.604	5.2	12050	78	0.098312	0.09996	0.000029	12252	0.09996
23	60.1	12.28	291.5	-2.2	2217	1	-0.018088	-0.000742	0	60835	0.000739
	10	14.765	671.6	2.7	-288	1993	-0.002351	-0.002351	180.5	111	0.001076
		0.002389	54.9	6.4	90.41	91				1171	4.28
41	0.125	0.076	0.604	5.8	12051	152	0.098369	0.100047	0.000056	12257	0.100047
24	49.7	8.42	291.2	-2.6	2238	-57	-0.018272	-0.000913	-0.000021	125290	0.001524
	10	14.766	670.9	2.3	-300	4109	-0.002445	-0.002445	265.7	228	0.000916
		0.002393	54.7	6.3	86.01	112				960	3.23
41	0.101	0.061	0.604	6.8	12110	212	0.098775	0.100426	0.000078	12312	0.100426
25	40.1	5.48	291.2	-3.4	2225	-48	-0.018149	-0.000721	-0.000018	222071	0.0027
	10	14.765	670.9	2.3	-356	7282	-0.002903	-0.002903	405.83	404	0.000913
		0.002395	54.7	6.3	78.85	88				755	2.2
41	0.091	0.055	0.605	7.4	12211	243	0.09916	0.100792	0.00009	12412	0.100792
26	36.2	4.47	291.8	-3.5	2226	-27	-0.018075	-0.000581	-0.00001	274727	0.003319
	10	14.765	672.3	2.3	-388	8991	-0.003153	-0.003153	498.1	500	0.000913
		0.002396	54.7	6.2	74.5	72				672	1.82
41	0.04	0.025	0.605	11.2	12223	133	0.09895	0.100627	0.000049	12430	0.100627
27	16.1	0.89	292.1	-3.2	2262	-118	-0.018312	-0.000852	-0.000043	553214	0.006655
	10	14.765	673	1.4	-470	18086	-0.003806	-0.003806	2541.62	1006	0.000482
		0.002398	54.7	6	37.98	105				299	0.54

RUN POINT	V/OR VKTS ALFS,U	MTUN QPSF BARO RHO	MTIP RPM OMEG*R TTEMPF	THETA A1 B1 CONING	LIFTH,C DRAGH,C SIDEH,C SKANGLE	PITCHH,S ROLLH,S TORQ,C HFORCE	CLRH/S CXRH/S CYRH/S	CLRHS/S CXRHS/S CYRHS/S	CMYHS/S CMXHS/S FE	THRUST POW HP VD	CTH/S CP/S CPO/S L/DR
41	0.029	0.018	0.606	11.6	12189	99	0.098574	0.100285	0.000036	12400	0.100285
28	11.6	0.46	292.2	-2.1	2284	-141	-0.018474	-0.001076	-0.000052	611072	0.007341
	10	14.765	673.2	1.1	-329	19970	-0.002659	-0.002659	4965.93	1111	0.001199
		0.002399	54.6	5.9	27.42	133				217	0.36
41	0.018	0.011	0.604	12.3	12296	33	0.099765	0.101429	0.000012	12501	0.101429
29	7.1	0.17	291.7	-1.3	2257	-216	-0.018309	-0.000707	-0.000079	703803	0.008497
	10	14.766	672	0.9	-231	23040	-0.001874	-0.001874	13273.93	1280	0.00225
		0.002399	54.6	5.8	16.53	87				129	0.2
41	0	0	0.603	12.5	12096	-447	0.098491	0.100003	-0.000165	12281	0.100003
30	0	0	291.2	-0.3	2128	-143	-0.017324	0.000042	-0.000053	722457	0.008769
	10	14.766	670.9	0.9	-69	23691	-0.000559	-0.000559	0	1314	0.002653
		0.002399	54.7	5.7	0.04	-5				0	0

APPENDIX C

**FORWARD FLIGHT
DYNAMIC LOADS DATA SUMMARY**

Forward Flight Dynamic Loads Data Summary

Summary of dynamic loads data are divided into two sections; thrust sweep data and speed sweep data. Data for both forward flight thrust sweep conditions and speed sweep conditions with minimized flapping trim are presented in tabulated form in this appendix. Thrust sweep data runs are grouped in terms of increasing rotor advance ratio and shaft angle-of-attack, α_s . Speed sweep data runs are grouped in terms of increasing shaft angle-of-attack, α_s , and thrust condition. For each of the measurements, the time-averaged mean and one-half peak-to-peak value (absolute maximum minus the absolute minimum divided by 2) are presented. Definitions of the measurements that are presented in this section are shown below. Identification of test conditions and its location within this appendix are presented following these definitions.

Nomenclature

ALFS,U, α_s	rotor shaft angle, positive aft of vertical, deg
b	number of rotor blades
c	airfoil chord length, ft
CTH/S	rotor thrust coefficient divided by rotor solidity, $\text{THRUST}/\rho(\Omega R)^2 S_R$
OMEG*R	rotor tip speed, ΩR , ft/sec
POINT	data point number
QPSF	free-stream dynamic pressure, lb/ft^2
R	rotor radius, ft
RHO, ρ	free-stream air density, ρ , slug/ ft^3
RUN	data run number
S_R	rotor blade area, bcR , ft^2
THRUST	rotor thrust, perpendicular to tip-path-plane, positive up, lb
V/OR, μ	rotor advance ratio, $V/\Omega R$
V	free-stream velocity, ft/s
VKTS	free-stream velocity, kt
Ω	rotor rotational speed, rad/s

Measurement Descriptions

<u>Parameter Name</u>	<u>Measurement Type</u>	<u>Location, r/R</u>	<u>Units</u>	<u>Positive Sign Convention</u>
MRNB1A	Flap Bending	0.127	ft-lb	tip up
MRNB2	Flap Bending	0.200	ft-lb	tip up
MRNB3	Flap Bending	0.300	ft-lb	tip up
MRNB7	Flap Bending	0.679	ft-lb	tip up
MRNB9A	Flap Bending	0.920	ft-lb	tip up
MREB1A	Chord Bending	0.127	ft-lb	leading edge tension
MREB2	Chord Bending	0.200	ft-lb	leading edge tension
MREB3	Chord Bending	0.300	ft-lb	leading edge tension
MREB4A	Chord Bending	0.454	ft-lb	leading edge tension
MRPR3	Pitch Link	0.05168	lb	tension
MRFLAP1	Blade Flap	≈ 0.060	deg	tip up

Thrust Sweep Dynamic Data Summary Index

V/OR Advance Ratio	ALFS,U deg	RUN	PTS	CTH/S	DATA LOCATION
0.050	-2	44	14-23	.030-->.120	C-8 to C-9
0.081	0	48	32-36	.038-->.075	C-9 to C-10
-----	-----	-----	-----	-----	-----
0.100	-15	63	9-18	.030-->.120	C-10 to C-11
0.100	-10	45	5-14	.030-->.120	C-11 to C-12
0.100	-2	44	6-13	.038-->.100	C-12 to C-14
0.100	5	46	5-10	.050-->.100	C-14 to C-14
0.100	10	47	5-8	.070-->.101	C-15 to C-15
		49	5-12	.070-->.120	C-15 to C-16
-----	-----	-----	-----	-----	-----
0.125	5	26	12-18	.054-->.111	C-16 to C-17
		29	5-12	.060-->.100	C-17 to C-18
0.125	10	30	5-11	.064-->.121	C-18 to C-19
-----	-----	-----	-----	-----	-----
0.150	-15	63	19-27	.031-->.111	C-19 to C-21
0.150	-10	21	23-31	.031-->.098	C-21 to C-22
		22	12-22	.023-->.119	C-22 to C-23
0.150	-2	24	7-13	.041-->.120	C-24 to C-24
0.150	5	28	7-14	.059-->.119	C-25 to C-26
0.150	10	30	12-17	.070-->.119	C-26 to C-27

**Thrust Sweep Dynamic Data Summary Index
(Continued)**

V/OR Advance Ratio	ALFS,U deg	RUN	PTS	CTH/S	DATA LOCATION
.200	-10	22 23	23-27 5-14	.014-->.060 .015-->.120	C-27 to C-27 C-27 to C-29
.200	-2	25	5-13	.041-->.118	C-29 to C-30
.200	5	28	15-21	.063-->.120	C-30 to C-31
.200	10	30	18-23	.078-->.121	C-31 to C-32
-----	-----	-----	-----	-----	-----
.250	-15	63	28-35	.031-->.090	C-32 to C-33
.250	-10	23	15-24	.030-->.116	C-33 to C-34
.250	-2	25	14-21	.038-->.105	C-34 to C-35
.250	5	29	13-19	.070-->.120	C-36 to C-36
.250	10	31	11-16	.083-->.120	C-37 to C-37

Speed Sweep Dynamic Data Summary Index

ALFS,U deg	CTH/S	RUN	PTS	V/OR Advance Ratio	DATA LOCATION
-10	0.065	36	6-11, 22-33	.251-->.006	C-38 to C-40
-5	0.065	51	5-18	.250-->.011	C-40 to C-42
-2	0.065	32	7-19	.250-->.000	C-42 to C-44
	0.065	34	5-18	.250-->.032	C-44 to C-46
5	0.065	38	5-21	.250-->.010	C-46 to C-49
-----	-----	-----	-----	-----	-----
-10	0.080	37	5-18	.251-->.011	C-48 to C-50
-5	0.080	53	5-10,12-21	.250-->.014	C-50 to C-53
-2	0.080	32	20-32	.250-->.000	C-51 to C-54
	0.080	35	5-19	.251-->.031	C-55 to C-57
0	0.080	48	5-31	.013->.250->0	C-57 to C-60
5	0.080	39	6-20	.250-->.011	C-61 to C-63
10	.0080	41	5-18	.252-->.010	C-63 to C-65
-----	-----	-----	-----	-----	-----
10	0.084	31	17-22	.252-->.080	C-65
-----	-----	-----	-----	-----	-----
-10	0.100	37	19-31	.251-->.011	C-66 to C-67
-2	0.100	33	5-15	.251-->.000	C-67 to C-69
		35	20-30	.251-->.030	C-69 to C-70
5	0.100	39	21-32	.249-->.010	C-71 to C-72
10	0.100	41	19-30	.251-->.000	C-72 to C-74

RUN POINT	V/OR VKTS	ALFS,U CTH/S	MRFLAP1 MRPR3 (MEAN)	MRNB1A MRNB2 MRNB3 (MEAN)	MREB1A MREB2 MREB3 (MEAN)	MREB4A MRNB7 MRNB9A (MEAN)	MRFLAP1 MRPR3 (1/2P-P)	MRNB1A MRNB2 MRNB3 (1/2P-P)	MREB1A MREB2 MREB3 (1/2P-P)	MREB4A MRNB7 MRNB9A (1/2P-P)
44	0.051	-2	2.2	87	-31	1207	0.5	127	241	192
14	20.5	0.029989	-21	-40 10	708 314	-28 5	158	111 88	209 220	108 54
44	0.051	-2	2.8	106	-41	1189	0.6	137	435	304
15	20.5	0.040676	-62	-27 19	688 294	-15 17	192	123 101	395 420	135 66
44	0.051	-2	3.3	130	12	1193	0.6	134	565	400
16	20.4	0.050599	-89	-11 29	716 302	2 29	208	117 100	546 566	151 88
44	0.051	-2	3.8	150	20	1172	0.6	143	616	513
17	20.4	0.060349	-119	3 38	707 284	20 40	219	118 97	624 664	168 92
44	0.051	-2	4.4	174	33	1149	0.6	140	658	623
18	20.4	0.071419	-150	20 49	703 264	38 51	292	112 97	650 733	177 97
44	0.051	-2	4.8	195	44	1126	0.6	144	659	657
19	20.5	0.079811	-172	33 59	698 244	51 59	279	112 92	632 730	184 104
44	0.051	-2	5.4	223	63	1096	0.6	161	649	635
20	20.4	0.091121	-200	53 72	693 222	66 70	314	123 99	613 688	187 106

RUN POINT	V/OR VKTS	ALFS,U CTH/S	MRFLAP1 MRPR3 (MEAN)	MRNB1A MRNB2 MRNB3 (MEAN)	MREB1A MREB2 MREB3 (MEAN)	MREB4A MRNB7 MRNB9A (MEAN)	MRFLAP1 MRPR3 (1/2P-P)	MRNB1A MRNB2 MRNB3 (1/2P-P)	MREB1A MREB2 MREB3 (1/2P-P)	MREB4A MRNB7 MRNB9A (1/2P-P)
44	0.051	-2	5.9	250	91	1075	0.6	172	636	657
21	20.4	0.100996	-220	70	699	79	335	121	603	200
				84	208	78		103	687	106
44	0.051	-2	6.3	276	122	1057	0.6	178	677	725
22	20.4	0.110613	-240	89	706	90	368	123	676	204
				97	202	87		96	749	106
44	0.051	-2	6.8	306	179	1069	0.6	185	753	869
23	20.4	0.119939	-266	109	739	96	396	127	788	200
				109	222	95		101	901	105
48	0.081	0	2.7	99	-51	1208	0.5	107	199	237
32	32.4	0.037936	-45	-37	679	-47	143	92	182	108
				-23	310	-4		77	215	52
48	0.081	0	3.4	125	-7	1230	0.6	188	495	363
33	32.4	0.050123	-75	-21	707	-43	197	155	501	152
				-13	318	1		110	474	73
48	0.081	0	3.9	145	16	1222	0.6	223	610	516
34	32.5	0.059503	-96	-7	709	-38	217	180	640	183
				-6	320	6		132	661	94
48	0.081	0	4.4	169	27	1218	0.7	262	734	735
35	32.5	0.069915	-123	8	707	-32	272	214	777	207
				4	311	14		157	825	111

RUN POINT	V/OR VKTS	ALFS,U CTH/S	MRFLAP1 MRPR3 (MEAN)	MRNB1A MRNB2 MRNB3 (MEAN)	MREB1A MREB2 MREB3 (MEAN)	MREB4A MRNB7 MRNB9A (MEAN)	MRFLAP1 MRPR3 (1/2P-P)	MRNB1A MRNB2 MRNB3 (1/2P-P)	MREB1A MREB2 MREB3 (1/2P-P)	MREB4A MRNB7 MRNB9A (1/2P-P)
48	0.081	0	4.7	180	30	1205	0.7	280	765	822
36	32.5	0.074841	-135	17 10	702 299	-29 18	301	214 166	813 867	220 117
63	0.1	-14.99	-0.2	105	29	1244	0.4	28	165	143
9	40.3	0.02978	-89	-17 84	749 328	-26 -5	96	25 28	142 160	56 23
63	0.101	-14.99	0.4	128	49	1246	0.4	40	327	206
10	40.3	0.040431	-108	-3 95	754 331	-21 -1	126	31 34	265 268	70 34
63	0.101	-14.99	0.9	142	25	1244	0.5	52	429	297
11	40.4	0.050346	-136	8 119	735 312	-16 3	158	37 39	349 370	87 44
63	0.101	-15	1.4	163	48	1251	0.5	70	567	449
12	40.4	0.060376	-155	21 127	745 314	-9 10	210	44 44	523 541	99 52
63	0.101	-15	1.9	186	70	1241	0.5	84	570	453
13	40.4	0.070326	-172	37 137	746 310	-3 15	246	44 42	501 539	108 60
63	0.101	-15	2.4	209	91	1238	0.6	95	578	460
14	40.3	0.080332	-191	52 148	752 303	6 22	257	46 48	497 550	118 67

RUN POINT	V/OR VKTS	ALFS,U CTH/S	MRFLAP1 MRPR3 (MEAN)	MRNB1A MRNB2 MRNB3 (MEAN)	MREB1A MREB2 MREB3 (MEAN)	MREB4A MRNB7 MRNB9A (MEAN)	MRFLAP1 MRPR3 (1/2P-P)	MRNB1A MRNB2 MRNB3 (1/2P-P)	MREB1A MREB2 MREB3 (1/2P-P)	MREB4A MRNB7 MRNB9A (1/2P-P)
63	0.1	-15	2.9	235	122	1237	0.5	102	590	460
15	40.3	0.090203	-206	68 159	763 300	13 28	285	49 52	533 576	130 72
63	0.101	-15	3.4	260	150	1223	0.6	113	591	490
16	40.4	0.09993	-223	85 171	767 294	22 35	321	52 58	535 597	140 75
63	0.101	-15	3.9	283	168	1204	0.7	130	624	529
17	40.4	0.109795	-239	102 181	765 285	30 42	333	57 64	573 643	150 82
63	0.1	-15	4.4	314	212	1257	0.7	186	660	601
18	40.3	0.119581	-286	122 414	803 320	31 37	486	78 79	611 707	157 99
45	0.099	-10	2.2	103	22	1255	0.3	43	181	144
5	39.8	0.030156	-19	-31 6	743 340	-37 -1	155	38 36	155 163	62 29
45	0.099	-10	2.7	121	18	1245	0.3	56	307	217
6	39.8	0.039968	-42	-18 13	731 331	-33 5	146	47 43	250 260	81 41
45	0.1	-10	3.3	137	1	1234	0.4	73	476	328
7	39.9	0.050515	-72	-6 21	712 313	-27 13	191	60 51	402 423	102 55

RUN POINT	V/OR VKTS	ALFS,U CTH/S	MRFLAP1 MRPR3 (MEAN)	MRNB1A MRNB2 MRNB3 (MEAN)	MREB1A MREB2 MREB3 (MEAN)	MREB4A MRNB7 MRNB9A (MEAN)	MRFLAP1 MRPR3 (1/2P-P)	MRNB1A MRNB2 MRNB3 (1/2P-P)	MREB1A MREB2 MREB3 (1/2P-P)	MREB4A MRNB7 MRNB9A (1/2P-P)
45	0.1	-10	3.8	159	28	1226	0.4	79	558	450
8	40	0.060762	-90	8	718	-20	235	69	502	118
				30	311	20		63	536	66
45	0.1	-10	4.3	180	46	1219	0.5	85	573	435
9	40	0.070472	-110	23	720	-14	257	75	512	132
				38	307	26		67	542	77
45	0.1	-10	4.9	205	77	1211	0.6	106	586	471
10	40	0.081048	-126	39	731	-6	281	76	504	149
				50	305	35		73	566	87
45	0.1	-10	5.4	228	100	1197	0.6	115	602	497
11	40	0.090024	-142	55	734	2	307	80	537	157
				59	299	42		81	584	95
45	0.1	-10	5.9	258	141	1195	0.8	129	614	548
12	40	0.100513	-158	73	751	9	340	87	566	167
				72	300	52		87	636	100
45	0.1	-10	6.4	282	163	1196	0.8	166	653	581
13	40	0.110049	-188	90	759	15	453	94	626	176
				83	301	60		86	678	113
45	0.1	-10	6.8	304	183	1242	0.9	220	700	727
14	40.1	0.120002	-248	107	787	13	533	105	736	175
				94	333	68		98	844	130

RUN POINT	V/OR VKTS	ALFS,U CTH/S	MRFLAP1 MRPR3 (MEAN)	MRNB1A MRNB2 MRNB3 (MEAN)	MREB1A MREB2 MREB3 (MEAN)	MREB4A MRNB7 MRNB9A (MEAN)	MRFLAP1 MRPR3 (1/2P-P)	MRNB1A MRNB2 MRNB3 (1/2P-P)	MREB1A MREB2 MREB3 (1/2P-P)	MREB4A MRNB7 MRNB9A (1/2P-P)
44	0.102	-2	2.6	111	29	1262	0.4	74	196	208
6	40.6	0.037875	-4	-32	747	-50	143	62	200	88
				9	364	-4		61	220	44
44	0.101	-2	2.8	117	3	1253	0.4	90	205	234
7	40.7	0.040999	-14	-28	728	-49	148	74	208	96
				9	348	-2		68	228	50
44	0.101	-2	3.3	129	-30	1241	0.4	135	434	277
8	40.6	0.04991	-43	-19	701	-46	190	111	404	120
				15	326	1		83	372	63
44	0.101	-2	3.8	151	8	1244	0.5	169	567	509
9	40.6	0.060499	-62	-5	717	-44	261	137	552	150
				24	333	5		101	593	77
44	0.101	-2	4.4	173	18	1243	0.6	205	683	651
10	40.7	0.070523	-82	9	716	-40	264	161	721	174
				33	327	11		118	717	97
44	0.101	-2	4.9	196	36	1238	0.7	247	733	793
11	40.6	0.080408	-101	25	717	-35	293	182	798	204
				44	319	17		139	821	113
44	0.101	-2	5.4	218	55	1230	0.8	273	756	844
12	40.7	0.090072	-120	40	719	-29	327	209	814	226
				55	312	23		148	859	121

RUN POINT	V/OR VKTS	ALFS,U CTH/S	MRFLAP1 MRPR3 (MEAN)	MRNB1A MRNB2 MRNB3 (MEAN)	MREB1A MREB2 MREB3 (MEAN)	MREB4A MRNB7 MRNB9A (MEAN)	MRFLAP1 MRPR3 (1/2P-P)	MRNB1A MRNB2 MRNB3 (1/2P-P)	MREB1A MREB2 MREB3 (1/2P-P)	MREB4A MRNB7 MRNB9A (1/2P-P)
44	0.101	-2	5.9	241	75	1225	0.9	291	773	942
13	40.7	0.10001	-137	56	723	-22	358	225	819	248
				65	304	30		153	942	126
46	0.1	5	4.5	143	-9	1286	0.5	197	516	314
5	40	0.069881	-94	-13	707	-61	226	125	451	129
				6	373	-1		100	453	93
46	0.1	5	6.1	203	57	1289	0.6	414	711	794
6	40	0.099769	-149	27	738	-52	326	274	821	223
				35	373	9		180	946	128
46	0.1	5	3.4	105	-45	1279	0.5	90	266	229
7	40.1	0.049816	-49	-36	691	-66	188	62	276	87
				-5	374	-10		62	270	48
46	0.101	5	4	122	-39	1274	0.4	164	480	338
8	40.2	0.060181	-74	-26	690	-64	213	92	411	111
				0	373	-7		83	393	73
46	0.1	5	4.5	141	-15	1276	0.5	193	512	325
9	40.1	0.069827	-92	-14	702	-62	236	121	433	131
				7	374	-4		101	450	92
46	0.101	5	5	160	8	1273	0.5	241	586	460
10	40.1	0.079865	-111	-2	711	-59	283	146	554	174
				16	378	0		115	581	116

RUN POINT	V/OR VKTS	ALFS,U CTH/S	MRFLAP1 MRPR3 (MEAN)	MRNB1A MRNB2 MRNB3 (MEAN)	MREB1A MREB2 MREB3 (MEAN)	MREB4A MRNB7 MRNB9A (MEAN)	MRFLAP1 MRPR3 (1/2P-P)	MRNB1A MRNB2 MRNB3 (1/2P-P)	MREB1A MREB2 MREB3 (1/2P-P)	MREB4A MRNB7 MRNB9A (1/2P-P)
47	0.101	10	4.6	148	-22	1351	0.7	139	518	349
5	40	0.070013	-32	-30	723	-80	206	106	454	94
				-12	428	-3		95	432	47
47	0.1	10	5.2	166	-6	1370	0.6	253	557	393
6	39.9	0.080596	-52	-20	739	-78	258	160	521	128
				-8	446	0		102	501	70
47	0.1	10	5.7	181	1	1380	0.7	274	623	567
7	39.9	0.090138	-71	-11	748	-76	261	185	592	140
				-2	451	3		108	593	77
47	0.1	10	6.3	203	50	1392	0.6	262	639	718
8	40	0.101203	-92	3	781	-74	275	182	639	129
				4	478	8		117	774	78
49	0.1	10	4.6	140	-33	1331	0.7	140	530	357
5	39.9	0.070314	-26	-25	701	-82	225	106	463	98
				-12	402	-5		90	439	54
49	0.1	10	6.2	192	27	1366	0.6	240	614	693
6	39.9	0.099873	-82	5	747	-76	264	176	592	126
				1	442	55		130	730	76
49	0.1	10	4.6	135	-37	1328	0.7	140	515	345
7	39.9	0.069544	-22	-27	701	-82	222	104	459	95
				-14	413	45		92	430	57

RUN POINT	V/OR VKTS	ALFS,U CTH/S	MRFLAP1 MRPR3 (MEAN)	MRNB1A MRNB2 MRNB3 (MEAN)	MREB1A MREB2 MREB3 (MEAN)	MREB4A MRNB7 MRNB9A (MEAN)	MRFLAP1 MRPR3 (1/2P-P)	MRNB1A MRNB2 MRNB3 (1/2P-P)	MREB1A MREB2 MREB3 (1/2P-P)	MREB4A MRNB7 MRNB9A (1/2P-P)
49	0.1	10	5.1	153	-24	1341	0.6	236	554	395
8	39.8	0.079887	-43	-16	710	-81	261	147	517	124
				-10	428	48		103	485	64
49	0.1	10	5.7	170	-10	1348	0.6	273	620	536
9	39.8	0.088993	-62	-7	719	-78	288	188	610	139
				-5	434	56		117	581	77
49	0.1	10	6.2	191	25	1366	0.6	257	616	697
10	39.8	0.09953	-81	5	746	-77	277	180	597	131
				2	441	55		123	735	79
49	0.1	10	6.8	212	58	1375	0.6	333	737	793
11	39.8	0.109717	-96	18	765	-73	327	208	837	162
				8	452	15		137	928	134
49	0.1	10	7.3	233	71	1372	0.8	445	924	871
12	39.7	0.119753	-120	34	766	-71	436	263	1217	229
				23	445	-152		173	1176	191
26	0.124	5	3.6	125	-40	1440	0.6	71	240	261
12	49.5	0.054297	-22	-30	702	-76	171	56	225	81
				30	409	-7		59	289	34
26	0.124	5	4	135	-31	1442	0.6	69	434	301
13	49.5	0.060327	-38	-24	707	-75	198	60	375	96
				497	412	-5		133	375	38

RUN POINT	V/OR VKTS	ALFS,U CTH/S	MRFLAP1 MRPR3 (MEAN)	MRNB1A MRNB2 MRNB3 (MEAN)	MREB1A MREB2 MREB3 (MEAN)	MREB4A MRNB7 MRNB9A (MEAN)	MRFLAP1 MRPR3 (1/2P-P)	MRNB1A MRNB2 MRNB3 (1/2P-P)	MREB1A MREB2 MREB3 (1/2P-P)	MREB4A MRNB7 MRNB9A (1/2P-P)
26	0.124	5	4.5	150	-24	1450	0.6	121	511	347
14	49.5	0.069705	-64	-14 929	709 416	-74 -3	207	78 380	424 410	123 57
26	0.124	5	5	169	-16	1456	0.6	166	599	479
15	49.5	0.080041	-71	-2 718	711 420	-73 0	227	90 371	545 566	142 93
26	0.124	5	5.6	190	4	1460	0.6	226	667	650
16	49.5	0.090229	-76	10 335	717 424	-70 2	242	120 396	650 696	162 117
26	0.124	5	6.2	209	22	1469	0.6	279	674	699
17	49.5	0.100309	-87	22 341	726 429	-69 -3	282	129 356	680 747	186 144
26	0.124	5	6.7	228	47	1473	0.6	299	719	765
18	49.5	0.110601	-116	35 430	739 424	-66 -17	329	141 674	705 837	202 153
29	0.125	5	4	136	-36	1437	0.5	73	401	295
5	50.1	0.060347	-35	-22 2528	707 406	-76 -16	169	61 306	368 365	98 39
29	0.125	5	4.5	150	-40	1438	0.5	122	508	348
6	50.1	0.069715	-54	-13 2416	699 403	-75 -46	213	84 999	432 424	124 56

RUN POINT	V/OR VKTS	ALFS,U CTH/S	MRFLAP1 MRPR3 (MEAN)	MRNB1A MRNB2 MRNB3 (MEAN)	MREB1A MREB2 MREB3 (MEAN)	MREB4A MRNB7 MRNB9A (MEAN)	MRFLAP1 MRPR3 (1/2P-P)	MRNB1A MRNB2 MRNB3 (1/2P-P)	MREB1A MREB2 MREB3 (1/2P-P)	MREB4A MRNB7 MRNB9A (1/2P-P)
29	0.125	5	5.1	169	-28	1456	0.5	158	583	461
7	50.1	0.080014	-71	-2 2123	709 410	-74 -51	230	91 989	539 559	143 90
29	0.125	5	5.6	187	-8	1459	0.5	223	652	630
8	50.1	0.089774	-86	10 1471	715 419	-72 -59	231	113 1159	625 681	156 114
29	0.125	5	6.2	207	15	1469	0.4	284	670	711
9	50.1	0.099992	-104	23 2502	727 429	-70 -41	272	140 600	672 734	193 154
29	0.125	5	5.7	186	-8	1456	0.4	234	655	633
10	50	0.090746	-86	10 2280	715 421	-72 -46	248	118 1057	629 693	159 123
29	0.125	5	5.7	186	-6	1453	0.5	232	659	635
11	50	0.091056	-86	11 1654	714 420	-72 -47	248	119 1146	647 705	163 122
29	0.125	5	5.7	187	-6	1447	0.5	234	650	645
12	50	0.090904	-87	11 698	713 419	-71 -39	252	120 1286	632 696	163 122
30	0.125	10.01	4.3	133	-70	1392	0.6	79	394	327
5	49.9	0.064353	-18	-26 1295	676 390	-85 -13	171	74 987	376 388	75 32

RUN POINT	V/OR VKTS	ALFS,U CTH/S	MRFLAP1 MRPR3 (MEAN)	MRNB1A MRNB2 MRNB3 (MEAN)	MREB1A MREB2 MREB3 (MEAN)	MREB4A MRNB7 MRNB9A (MEAN)	MRFLAP1 MRPR3 (1/2P-P)	MRNB1A MRNB2 MRNB3 (1/2P-P)	MREB1A MREB2 MREB3 (1/2P-P)	MREB4A MRNB7 MRNB9A (1/2P-P)
30	0.125	10.01	4.6	142	-76	1400	0.6	116	490	373
6	49.9	0.070391	-29	-21 2438	673 388	-87 -39	198	93 482	439 460	82 46
30	0.125	10.01	5.2	158	-73	1406	0.7	156	530	383
7	49.9	0.080061	-43	-11 2521	670 390	-89 -31	227	120 702	479 485	97 50
30	0.124	10.01	5.7	176	-64	1428	0.6	159	543	400
8	49.9	0.090345	-59	-1 2148	677 399	-94 -41	221	129 822	496 477	122 68
30	0.125	10.01	6.2	192	-46	1440	0.7	145	550	476
9	49.9	0.099661	-72	9 2549	684 412	-96 -38	239	122 488	506 526	125 63
30	0.124	10.01	6.8	212	-16	1468	0.7	182	588	592
10	49.9	0.10977	-87	21 2491	707 416	-96 -46	266	138 892	566 600	144 65
30	0.125	10.01	7.4	234	9	1484	0.6	180	676	677
11	49.9	0.121272	-102	34 2380	719 439	-91 -35	283	116 907	664 676	139 64
63	0.151	-15	-0.1	107	60	1251	0.5	31	197	196
19	60.3	0.030681	-90	-11 334	770 330	-27 -35	166	22 32	183 194	59 23

RUN POINT	V/OR VKTS	ALFS,U CTH/S	MRFLAP1 MRPR3 (MEAN)	MRNB1A MRNB2 MRNB3 (MEAN)	MREB1A MREB2 MREB3 (MEAN)	MREB4A MRNB7 MRNB9A (MEAN)	MRFLAP1 MRPR3 (1/2P-P)	MRNB1A MRNB2 MRNB3 (1/2P-P)	MREB1A MREB2 MREB3 (1/2P-P)	MREB4A MRNB7 MRNB9A (1/2P-P)
63	0.15	-15	0.4	118	-15	1226	0.4	41	337	288
20	60.1	0.040739	-126	-1	712	-24	149	23	302	73
				342	284	-32		36	343	29
63	0.151	-15	0.9	140	27	1234	0.4	65	512	418
21	60.2	0.050253	-140	13	732	-24	192	21	465	83
				351	297	-28		40	503	36
63	0.151	-15	1.4	162	51	1244	0.4	75	546	442
22	60.3	0.060507	-155	27	743	-22	218	27	488	93
				360	302	-25		46	532	41
63	0.151	-15	1.9	188	80	1253	0.5	86	556	432
23	60.4	0.070393	-170	42	754	-19	248	34	497	104
				369	308	-21		52	532	47
63	0.15	-15	2.4	212	114	1261	0.6	100	577	474
24	60.2	0.080009	-185	57	770	-15	278	39	513	116
				381	311	-17		57	585	52
63	0.151	-15	2.9	238	140	1253	0.6	107	605	531
25	60.4	0.090769	-199	75	773	-11	298	46	567	128
				392	307	-11		64	646	58
63	0.151	-15	3.4	262	159	1251	0.6	117	632	582
26	60.5	0.100854	-215	91	777	-7	321	51	602	138
				402	304	-6		67	705	63

RUN POINT	V/OR VKTS	ALFS,U CTH/S	MRFLAP1 MRPR3 (MEAN)	MRNB1A MRNB2 MRNB3 (MEAN)	MREB1A MREB2 MREB3 (MEAN)	MREB4A MRNB7 MRNB9A (MEAN)	MRFLAP1 MRPR3 (1/2P-P)	MRNB1A MRNB2 MRNB3 (1/2P-P)	MREB1A MREB2 MREB3 (1/2P-P)	MREB4A MRNB7 MRNB9A (1/2P-P)
63	0.152	-15	3.9	287	181	1247	0.7	130	653	628
27	60.6	0.110735	-228	107 412	781 301	-2 1	356	61 72	642 754	151 68
21	0.151	-10.01	2.3	82	1	1410	0.3	33	170	158
23	60.1	0.030861	-70	-30 26	730 394	-43 2	106	30 37	138 171	67 27
21	0.151	-10.01	2.7	98	-41	1395	0.3	39	299	273
24	60	0.040117	-97	-19 33	695 366	-41 4	169	31 43	254 297	81 35
21	0.151	-10.01	3.3	120	-34	1408	0.4	64	509	408
25	60	0.050374	-119	-5 41	707 371	-39 9	246	38 49	447 488	99 44
21	0.151	-10.01	3.8	140	-18	1416	0.5	71	568	462
26	60.1	0.059195	-133	8 49	716 374	-37 12	226	54 57	514 552	115 52
21	0.151	-10.01	4.4	167	10	1418	0.5	86	579	440
27	60.1	0.071094	-150	26 60	724 375	-34 16	265	69 68	499 538	133 60
21	0.152	-10.01	4.9	190	46	1408	0.6	99	625	538
28	60.1	0.080148	-161	41 69	735 379	-30 21	299	74 74	566 620	140 69

RUN POINT	V/OR VKTS	ALFS,U CTH/S	MRFLAP1 MRPR3 (MEAN)	MRNB1A MRNB2 MRNB3 (MEAN)	MREB1A MREB2 MREB3 (MEAN)	MREB4A MRNB7 MRNB9A (MEAN)	MRFLAP1 MRPR3 (1/2P-P)	MRNB1A MRNB2 MRNB3 (1/2P-P)	MREB1A MREB2 MREB3 (1/2P-P)	MREB4A MRNB7 MRNB9A (1/2P-P)
21	0.152	-10.01	5.4	210	60	1411	0.6	109	625	565
29	60.1	0.089108	-174	55 78	735 370	-27 25	322	86 82	577 668	153 74
21	0.152	-10.01	5.8	231	74	1401	0.8	119	643	626
30	60.1	0.097821	-187	69 85	732 360	-23 30	356	93 89	607 718	165 78
21	0.154	-10.01	1.8	56	-40	1356	0.4	33	90	141
31	60.1	0.021766	-52	-42 16	691 377	-43 1	80	30 42	91 143	66 23
22	0.151	-9.99	1.8	81	-47	1412	0.4	32	96	144
12	60.4	0.023013	-46	-37 16	732 361	-42 -8	89	31 39	89 138	65 24
22	0.151	-9.99	2.2	97	-4	1414	0.5	31	150	153
13	60.3	0.030279	-54	-27 22	748 372	-42 -6	109	30 37	133 166	68 28
22	0.151	-9.99	2.7	113	-56	1417	0.4	41	293	261
14	60.4	0.040197	-82	-16 29	715 346	-40 -3	138	30 44	232 279	81 35
22	0.151	-9.99	3.2	129	-54	1409	0.4	58	481	390
15	60.4	0.049579	-104	-4 36	705 338	-38 0	183	33 47	410 461	98 42

RUN POINT	V/OR VKTS	ALFS,U CTH/S	MRFLAP1 MRPR3 (MEAN)	MRNB1A MRNB2 MRNB3 (MEAN)	MREB1A MREB2 MREB3 (MEAN)	MREB4A MRNB7 MRNB9A (MEAN)	MRFLAP1 MRPR3 (1/2P-P)	MRNB1A MRNB2 MRNB3 (1/2P-P)	MREB1A MREB2 MREB3 (1/2P-P)	MREB4A MRNB7 MRNB9A (1/2P-P)
22	0.151	-9.99	3.8	153	-10	1425	0.5	76	570	457
16	60.4	0.059949	-117	11 45	728 349	-36 4	239	55 58	510 547	118 53
22	0.151	-9.99	4.2	173	15	1431	0.5	84	575	439
17	60.4	0.068933	-128	24 53	738 349	-33 8	264	65 65	505 537	128 61
22	0.152	-9.99	4.8	200	47	1422	0.6	98	622	542
18	60.4	0.08013	-143	42 64	742 347	-30 13	340	78 74	561 620	143 69
22	0.151	-9.99	5.3	225	70	1424	0.7	109	622	585
19	60.4	0.090163	-154	57 75	748 342	-26 18	317	87 82	582 675	156 74
22	0.152	-9.99	5.8	248	86	1416	0.8	124	643	635
20	60.4	0.100358	-172	74 85	747 331	-21 23	350	94 92	603 717	169 82
22	0.151	-9.99	6.3	272	97	1406	0.9	141	687	682
21	60.4	0.110253	-189	90 108	743 316	-15 30	389	108 101	678 790	184 87
22	0.151	-9.99	6.8	295	114	1409	0.9	171	716	756
22	60.4	0.119478	-212	106 107	748 309	-11 36	464	128 115	723 862	198 101

RUN POINT	V/OR VKTS	ALFS,U CTH/S	MRFLAP1 MRPR3 (MEAN)	MRNB1A MRNB2 MRNB3 (MEAN)	MREB1A MREB2 MREB3 (MEAN)	MREB4A MRNB7 MRNB9A (MEAN)	MRFLAP1 MRPR3 (1/2P-P)	MRNB1A MRNB2 MRNB3 (1/2P-P)	MREB1A MREB2 MREB3 (1/2P-P)	MREB4A MRNB7 MRNB9A (1/2P-P)
24	0.151	-1.99	2.8	107	20	1457	0.6	42	202	245
7	60.2	0.04074	-41	-30 9	742 403	-61 -9	119	36 50	207 260	87 34
24	0.15	-1.99	3.9	139	-21	1445	0.4	67	541	413
8	60.1	0.060479	-90	-7 20	699 365	-59 -6	200	55 62	494 500	121 46
24	0.15	-1.99	5	179	5	1450	0.6	107	639	544
9	60.2	0.079756	-124	20 70	701 356	-58 -3	281	86 91	622 662	161 74
24	0.151	-1.99	5.5	200	27	1448	0.6	120	673	628
10	60.2	0.089614	-132	33 52	702 358	-57 -3	315	93 84	671 719	177 84
24	0.151	-1.99	6.1	225	54	1409	0.6	137	717	729
11	60.2	0.10043	-146	49 65	710 358	-55 3	369	107 89	735 818	199 105
24	0.15	-1.99	6.5	247	69	1415	0.7	160	752	775
12	60.2	0.109572	-160	62 73	719 361	-54 9	399	121 103	779 877	216 115
24	0.151	-1.99	7	268	93	1409	0.9	189	755	755
13	60.3	0.119757	-177	78 91	725 361	-52 14	462	129 120	758 855	222 120

RUN POINT	V/OR VKTS	ALFS,U CTH/S	MRFLAP1 MRPR3 (MEAN)	MRNB1A MRNB2 MRNB3 (MEAN)	MREB1A MREB2 MREB3 (MEAN)	MREB4A MRNB7 MRNB9A (MEAN)	MRFLAP1 MRPR3 (1/2P-P)	MRNB1A MRNB2 MRNB3 (1/2P-P)	MREB1A MREB2 MREB3 (1/2P-P)	MREB4A MRNB7 MRNB9A (1/2P-P)
28	0.149	5	3.9	136	-36	1448	0.5	86	355	304
7	60.2	0.058629	-12	-24 1065	706 385	-82 -23	174	58 153	341 367	95 40
28	0.151	5	4.6	152	-49	1430	0.5	110	519	391
8	60.2	0.070249	-34	-11 1046	678 368	-85 -17	218	76 213	442 473	105 53
28	0.15	5	5.1	172	-44	1448	0.5	120	576	468
9	60.2	0.080313	-50	1 848	679 367	-87 -31	234	77 327	521 506	129 64
28	0.15	5	5.7	190	-28	1460	0.5	126	593	548
10	60.2	0.089612	-63	12 457	685 372	-88 -42	241	84 274	533 595	150 78
28	0.151	5	6.3	210	-8	1462	0.5	156	611	585
11	60.2	0.100962	-79	27 782	684 376	-89 -43	271	101 939	595 654	172 80
28	0.151	5	6.8	228	13	1474	0.5	197	624	574
12	60.3	0.109708	-89	38 1273	693 383	-88 -34	281	116 1275	607 684	185 91
28	0.151	5	7.3	248	33	1487	0.5	203	637	614
13	60.2	0.119313	-101	51 779	702 385	-86 -45	301	122 1376	627 682	197 103

RUN POINT	V/OR VKTS	ALFS,U CTH/S	MRFLAP1 MRPR3 (MEAN)	MRNB1A MRNB2 MRNB3 (MEAN)	MREB1A MREB2 MREB3 (MEAN)	MREB4A MRNB7 MRNB9A (MEAN)	MRFLAP1 MRPR3 (1/2P-P)	MRNB1A MRNB2 MRNB3 (1/2P-P)	MREB1A MREB2 MREB3 (1/2P-P)	MREB4A MRNB7 MRNB9A (1/2P-P)
28	0.151	5	6.8	228	15	1477	0.4	188	623	579
14	60.3	0.110459	-88	39 1399	694 366	-87 -56	298	111 1323	612 679	188 93
30	0.15	10.01	4.7	137	-102	1397	0.6	74	477	397
12	60	0.070559	-12	-24 2355	646 366	-97 -15	199	74 717	459 490	91 35
30	0.15	10.01	5.2	155	-102	1408	0.6	89	541	425
13	60.1	0.080138	-28	-14 2589	644 362	-97 -15	239	80 0	520 543	96 42
30	0.15	10.01	5.8	172	-102	1410	0.6	88	535	440
14	60.1	0.089748	-45	-2 2589	635 357	-99 -9	233	78 0	469 516	114 44
30	0.151	10.01	6.4	191	-89	1418	0.6	98	557	551
15	60.1	0.099822	-58	9 2589	636 360	-102 -43	295	83 0	529 606	120 53
30	0.15	10.01	7	212	-71	1436	0.6	162	574	591
16	60.1	0.110732	-71	22 2586	644 370	-103 -48	266	106 452	544 688	137 65
30	0.15	10.01	7.5	230	-50	1448	0.7	159	602	635
17	59.9	0.119384	-82	33 2527	651 378	-107 -48	314	115 525	599 748	148 72

RUN POINT	V/OR VKTS	ALFS,U CTH/S	MRFLAP1 MRPR3 (MEAN)	MRNB1A MRNB2 MRNB3 (MEAN)	MREB1A MREB2 MREB3 (MEAN)	MREB4A MRNB7 MRNB9A (MEAN)	MRFLAP1 MRPR3 (1/2P-P)	MRNB1A MRNB2 MRNB3 (1/2P-P)	MREB1A MREB2 MREB3 (1/2P-P)	MREB4A MRNB7 MRNB9A (1/2P-P)
22	0.201	-9.99	1.3	53	-79	1388	0.4	52	74	165
23	80	0.01417	-44	-50	717	-39	78	46	109	77
				5	340	-9		53	159	25
22	0.2	-9.99	2.2	89	-59	1393	0.4	51	215	273
24	80	0.029925	-71	-28	722	-40	105	45	198	82
				18	335	-6		52	267	29
22	0.201	-9.99	2.7	105	-73	1388	0.4	56	379	341
25	80.1	0.039479	-93	-17	704	-41	153	49	348	91
				26	319	-2		51	400	34
22	0.201	-9.99	3.2	129	-24	1394	0.4	64	551	438
26	80.1	0.050337	-108	-1	724	-41	191	48	521	106
				35	328	1		57	549	39
22	0.201	-9.99	3.8	151	-8	1406	0.5	73	564	430
27	80.1	0.059689	-122	13	730	-42	225	50	516	115
				43	329	4		62	541	44
23	0.2	-10	1.3	59	-16	1410	0.5	47	77	167
5	79.9	0.014705	-42	-48	740	-39	75	44	106	75
				4	372	-10		51	168	23
23	0.2	-10	2.1	88	-1	1413	0.4	45	168	250
6	80	0.028391	-65	-30	741	-40	117	42	170	80
				16	367	-7		50	239	27

RUN POINT	V/OR VKTS	ALFS,U CTH/S	MRFLAP1 MRPR3 (MEAN)	MRNB1A MRNB2 MRNB3 (MEAN)	MREB1A MREB2 MREB3 (MEAN)	MREB4A MRNB7 MRNB9A (MEAN)	MRFLAP1 MRPR3 (1/2P-P)	MRNB1A MRNB2 MRNB3 (1/2P-P)	MREB1A MREB2 MREB3 (1/2P-P)	MREB4A MRNB7 MRNB9A (1/2P-P)
23	0.2	-10	3.2	131	32	1421	0.4	63	542	439
7	80.1	0.050584	-105	0 36	746 363	-41 0	193	45 59	509 552	106 38
23	0.2	-10	4.2	174	76	1427	0.5	86	569	490
8	80.1	0.07028	-132	29 53	756 363	-41 6	259	60 69	508 597	128 49
23	0.2	-10	5.2	219	123	1430	0.7	127	632	664
9	80.1	0.090233	-157	59 73	767 357	-39 13	313	79 82	622 759	152 62
23	0.2	-10	5.8	242	125	1432	0.8	123	693	776
10	80.2	0.100477	-171	74 82	760 341	-38 18	349	90 94	711 872	173 70
23	0.199	-10	6.3	265	145	1434	0.8	137	720	820
11	80.2	0.109954	-190	90 95	765 336	-35 19	406	98 99	755 924	184 77
23	0.201	-10	6.5	278	162	1419	1	152	713	811
12	80.2	0.115883	-201	100 105	765 332	-33 22	446	102 102	745 909	189 81
23	0.201	-10	6.8	290	179	1433	1.1	177	717	797
13	80.2	0.120308	-218	109 108	775 342	-32 23	556	116 110	708 878	196 88

RUN POINT	V/OR VKTS	ALFS,U CTH/S	MRFLAP1 MRPR3 (MEAN)	MRNB1A MRNB2 MRNB3 (MEAN)	MREB1A MREB2 MREB3 (MEAN)	MREB4A MRNB7 MRNB9A (MEAN)	MRFLAP1 MRPR3 (1/2P-P)	MRNB1A MRNB2 MRNB3 (1/2P-P)	MREB1A MREB2 MREB3 (1/2P-P)	MREB4A MRNB7 MRNB9A (1/2P-P)
23	0.201	-10.02	4.8	188	87	1414	0.6	102	597	561
14	80.1	0.079573	-134	40 64	749 352	-41 9	283	65 75	572 670	139 56
25	0.2	-2	2.8	115	-37	1403	0.6	73	219	304
5	79.8	0.040783	-9	-32 -6	699 369	-65 -7	114	65 71	237 314	108 44
25	0.2	-2	3.2	127	-70	1386	0.6	84	347	387
6	79.8	0.049286	-30	-23 2	664 342	-66 -7	149	65 72	312 384	118 54
25	0.201	-2	3.8	143	-41	1384	0.4	97	516	486
7	79.8	0.059193	-52	-10 37	672 342	-67 -8	202	72 79	460 512	129 69
25	0.2	-2	4.4	164	-27	1398	0.5	131	584	551
8	79.8	0.070165	-70	4 97	676 340	-69 -10	230	89 149	577 622	147 89
25	0.201	-2	4.9	182	-4	1395	0.4	150	595	523
9	79.8	0.079651	-75	18 198	677 338	-70 -8	282	98 182	568 616	161 102
25	0.201	-2	5.5	203	15	1400	0.6	190	648	645
10	79.8	0.090703	-69	33 198	680 342	-71 -4	325	110 404	659 740	185 114

RUN POINT	V/OR VKTS	ALFS,U CTH/S	MRFLAP1 MRPR3 (MEAN)	MRNB1A MRNB2 MRNB3 (MEAN)	MREB1A MREB2 MREB3 (MEAN)	MREB4A MRNB7 MRNB9A (MEAN)	MRFLAP1 MRPR3 (1/2P-P)	MRNB1A MRNB2 MRNB3 (1/2P-P)	MREB1A MREB2 MREB3 (1/2P-P)	MREB4A MRNB7 MRNB9A (1/2P-P)
25	0.201	-2	6	227	35	1401	0.6	228	693	790
11	79.9	0.100619	-97	49	683	-71	391	137	741	206
				146	331	3		386	849	127
25	0.201	-2	6.6	247	45	1412	0.7	242	732	829
12	79.8	0.110008	-124	63	687	-71	454	157	790	220
				177	342	2		939	867	137
25	0.201	-2	6.9	265	65	1422	0.8	228	744	762
13	79.9	0.11777	-151	75	702	-70	551	161	773	230
				143	-123	5		229	861	161
28	0.2	5	4.3	132	-80	1448	0.6	94	417	443
15	80	0.063276	-5	-24	664	-97	184	84	416	118
				1582	349	-73		1168	513	41
28	0.2	5	4.6	142	-92	1442	0.5	102	514	468
16	80	0.069245	-17	-17	650	-98	199	86	499	124
				1253	338	-48		1161	571	49
28	0.201	5	5.2	162	-81	1442	0.5	114	540	532
17	79.9	0.080135	-36	-4	646	-100	227	85	521	131
				1057	333	-8		1026	596	60
28	0.2	5	5.8	182	-68	1453	0.5	116	579	625
18	80	0.090119	-52	9	649	-103	256	83	554	139
				1233	330	-8		1007	684	67

RUN POINT	V/OR VKTS	ALFS,U CTH/S	MRFLAP1 MRPR3 (MEAN)	MRNB1A MRNB2 MRNB3 (MEAN)	MREB1A MREB2 MREB3 (MEAN)	MREB4A MRNB7 MRNB9A (MEAN)	MRFLAP1 MRPR3 (1/2P-P)	MRNB1A MRNB2 MRNB3 (1/2P-P)	MREB1A MREB2 MREB3 (1/2P-P)	MREB4A MRNB7 MRNB9A (1/2P-P)
28	0.2	5	6.4	200	-54	1448	0.5	143	628	691
19	80	0.100541	-68	22 1556	645 326	-105 -12	291	85 1053	614 760	151 85
28	0.2	5	6.9	221	-32	1465	0.4	188	645	669
20	80	0.110004	-80	35 2320	656 329	-107 -47	311	118 850	683 771	182 97
28	0.201	5	7.4	241	-23	1459	0.4	197	674	664
21	80	0.120153	-94	49 2290	649 320	-109 -48	331	124 1146	704 763	203 105
30	0.2	10.01	5.3	147	-143	1422	0.7	114	570	563
18	80.1	0.078438	-4	-21 2548	616 365	-116 -51	227	98 383	587 701	125 39
30	0.2	10.01	5.3	147	-143	1422	0.6	134	570	558
19	80.1	0.078359	-6	-21 2193	616 366	-116 -53	232	101 642	591 701	125 38
30	0.2	10.01	5.9	168	-150	1420	0.6	136	571	529
20	80.1	0.090082	-29	-8 2525	597 349	-119 -21	250	107 587	572 648	132 47
30	0.201	10.01	6.6	185	-143	1420	0.6	166	602	667
21	80.1	0.100239	-46	4 2301	593 343	-121 -49	291	117 542	624 735	143 56

RUN POINT	V/OR VKTS	ALFS,U CTH/S	MRFLAP1 MRPR3 (MEAN)	MRNB1A MRNB2 MRNB3 (MEAN)	MREB1A MREB2 MREB3 (MEAN)	MREB4A MRNB7 MRNB9A (MEAN)	MRFLAP1 MRPR3 (1/2P-P)	MRNB1A MRNB2 MRNB3 (1/2P-P)	MREB1A MREB2 MREB3 (1/2P-P)	MREB4A MRNB7 MRNB9A (1/2P-P)
30	0.201	10.01	7.1	205	-124	1424	0.6	140	638	757
22	80.1	0.110792	-64	16	595	-122	299	109	702	155
				2583	339	-48		252	861	61
30	0.201	10.01	7.7	224	-113	1414	0.6	138	654	809
23	80.1	0.121245	-82	29	586	-123	324	106	724	165
				2521	327	-36		546	917	65
63	0.251	-15	-0.2	103	21	1218	0.5	79	482	384
28	100.3	0.031099	-162	-5	754	-15	175	57	412	99
				350	300	-33		66	451	30
63	0.252	-15	0.3	127	41	1215	0.6	94	548	453
29	100.4	0.040903	-174	11	757	-17	203	60	504	103
				359	300	-30		64	535	32
63	0.251	-15	0.8	151	71	1224	0.6	122	592	568
30	100.2	0.050608	-191	27	773	-18	247	69	550	109
				371	305	-28		69	619	36
63	0.251	-15	1.3	176	98	1226	0.7	138	622	618
31	100.2	0.061048	-203	43	781	-21	266	77	590	122
				368	307	-25		74	679	39
63	0.252	-15	1.3	176	98	1226	0.6	138	613	616
32	100.2	0.061144	-203	43	779	-21	268	76	583	123
				363	306	-25		74	689	39

RUN POINT	V/OR VKTS	ALFS,U CTH/S	MRFLAP1 MRPR3 (MEAN)	MRNB1A MRNB2 MRNB3 (MEAN)	MREB1A MREB2 MREB3 (MEAN)	MREB4A MRNB7 MRNB9A (MEAN)	MRFLAP1 MRPR3 (1/2P-P)	MRNB1A MRNB2 MRNB3 (1/2P-P)	MREB1A MREB2 MREB3 (1/2P-P)	MREB4A MRNB7 MRNB9A (1/2P-P)
63	0.251	-15	1.8	200	130	1237	0.7	150	631	675
33	100.2	0.072299	-217	58 370	794 311	-22 -22	299	87 79	617 756	137 48
63	0.251	-15	2.3	225	162	1241	0.9	160	651	743
34	100.3	0.080806	-230	75 380	806 315	-23 -18	343	91 86	650 817	150 52
63	0.251	-15	2.7	251	196	1239	0.9	167	663	762
35	100.3	0.090196	-241	91 390	818 319	-23 -15	363	99 92	699 871	162 58
23	0.249	-10.01	2.2	81	-27	1395	0.5	65	317	345
15	99.9	0.03031	-83	-29 21	728 353	-36 -1	157	63 70	315 374	100 31
23	0.249	-10.01	2.5	97	11	1402	0.5	72	488	420
16	99.9	0.037123	-95	-18 41	749 364	-37 2	167	65 69	446 497	108 32
23	0.251	-10.01	3.2	127	39	1399	0.6	88	550	450
17	99.9	0.050367	-113	1 58	752 362	-40 5	212	68 70	482 518	116 34
23	0.25	-10.01	3.7	151	62	1402	0.6	105	584	560
18	99.9	0.060275	-128	17 65	758 359	-42 7	240	74 76	536 624	127 41

RUN POINT	V/OR VKTS	ALFS,U CTH/S	MRFLAP1 MRPR3 (MEAN)	MRNB1A MRNB2 MRNB3 (MEAN)	MREB1A MREB2 MREB3 (MEAN)	MREB4A MRNB7 MRNB9A (MEAN)	MRFLAP1 MRPR3 (1/2P-P)	MRNB1A MRNB2 MRNB3 (1/2P-P)	MREB1A MREB2 MREB3 (1/2P-P)	MREB4A MRNB7 MRNB9A (1/2P-P)
23	0.251	-10.01	4.1	168	83	1395	0.7	120	607	622
19	100	0.068641	-139	30	757	-43	262	81	570	140
				72	357	10		81	688	46
23	0.248	-10.01	4.7	199	119	1404	0.8	143	645	706
20	100	0.079208	-154	49	771	-45	301	95	621	160
				88	359	13		91	772	55
23	0.25	-10.01	5.2	223	141	1411	0.8	152	688	831
21	100	0.090581	-168	65	778	-46	343	105	741	176
				94	357	9		101	923	62
23	0.25	-10.01	5.7	246	161	1401	0.9	159	725	876
22	100	0.100551	-188	82	777	-45	387	108	788	196
				123	351	11		111	988	68
23	0.251	-10.01	6.2	267	181	1402	1	172	729	876
23	100.1	0.109185	-215	97	783	-45	465	111	775	211
				191	347	16		121	967	73
23	0.25	-10.01	6.5	295	221	1464	1.4	228	846	914
24	100	0.11616	-240	116	826	-46	648	149	912	219
				117	356	27		238	1107	107
25	0.25	-2	2.6	98	-44	1394	0.6	84	212	391
14	99.8	0.037787	6	-40	694	-67	99	86	285	123
				-3	362	-11		102	404	43

RUN POINT	V/OR VKTS	ALFS,U CTH/S	MRFLAP1 MRPR3 (MEAN)	MRNB1A MRNB2 MRNB3 (MEAN)	MREB1A MREB2 MREB3 (MEAN)	MREB4A MRNB7 MRNB9A (MEAN)	MRFLAP1 MRPR3 (1/2P-P)	MRNB1A MRNB2 MRNB3 (1/2P-P)	MREB1A MREB2 MREB3 (1/2P-P)	MREB4A MRNB7 MRNB9A (1/2P-P)
25	0.252	-2	3.3	120	-64	1374	0.6	99	453	502
15	99.7	0.050663	-26	-23 37	673 338	-71 -8	148	86 106	443 533	143 57
25	0.251	-2	3.9	141	-36	1386	0.5	104	573	574
16	99.8	0.060621	-29	-10 59	686 341	-73 -6	295	91 115	550 616	156 66
25	0.252	-2	4.4	158	-17	1381	0.6	121	594	598
17	99.8	0.069973	-35	4 97	688 340	-75 -5	212	93 116	565 634	166 78
25	0.251	-2	5	179	1	1389	0.6	128	585	636
18	99.8	0.080155	-28	18 151	694 337	-78 -2	368	93 141	565 646	175 91
25	0.25	-2	5.5	201	11	1391	0.6	146	627	723
19	99.9	0.089475	-71	32 143	692 320	-79 0	316	109 142	624 728	190 106
25	0.251	-2	6.1	223	25	1385	0.8	189	678	830
20	99.8	0.100379	28	47 223	688 316	-80 4	378	123 485	715 874	212 121
25	0.251	-2	6.3	235	43	1378	0.8	201	730	900
21	99.8	0.104838	137	55 243	697 346	-81 6	397	124 463	798 965	223 120

RUN POINT	V/OR VKTS	ALFS,U CTH/S	MRFLAP1 MRPR3 (MEAN)	MRNB1A MRNB2 MRNB3 (MEAN)	MREB1A MREB2 MREB3 (MEAN)	MREB4A MRNB7 MRNB9A (MEAN)	MRFLAP1 MRPR3 (1/2P-P)	MRNB1A MRNB2 MRNB3 (1/2P-P)	MREB1A MREB2 MREB3 (1/2P-P)	MREB4A MRNB7 MRNB9A (1/2P-P)
29	0.25	5	4.7	140	-128	1444	0.6	163	547	561
13	99.5	0.070069	-24	-22 1185	635 379	-106 -14	224	132 1210	573 673	149 44
29	0.25	5	5.3	157	-121	1439	0.6	145	557	635
14	99.7	0.079867	-42	-10 640	628 368	-108 -10	232	133 924	638 762	164 57
29	0.25	5	5.9	177	-102	1448	0.6	152	590	744
15	99.7	0.090516	-59	2 548	633 364	-109 -14	254	128 1300	670 827	177 67
29	0.25	5	6.4	195	-90	1434	0.5	151	625	782
16	99.7	0.099872	-76	15 497	625 351	-110 -8	263	143 630	734 875	186 67
29	0.25	5	7	216	-86	1433	0.5	169	614	845
17	99.7	0.110759	-93	29 783	615 323	-110 -34	295	137 1308	749 974	198 78
29	0.251	5	7.5	234	-79	1418	0.5	166	684	943
18	99.7	0.119931	-112	43 457	601 275	-110 -35	351	152 1322	786 1024	209 87
29	0.251	5	7.5	233	-80	1418	0.5	170	664	940
19	99.7	0.120031	-112	42 364	600 273	-110 -44	350	149 1329	786 1023	211 85

RUN POINT	V/OR VKTS	ALFS,U CTH/S	MRFLAP1 MRPR3 (MEAN)	MRNB1A MRNB2 MRNB3 (MEAN)	MREB1A MREB2 MREB3 (MEAN)	MREB4A MRNB7 MRNB9A (MEAN)	MRFLAP1 MRPR3 (1/2P-P)	MRNB1A MRNB2 MRNB3 (1/2P-P)	MREB1A MREB2 MREB3 (1/2P-P)	MREB4A MRNB7 MRNB9A (1/2P-P)
31	0.251	10.01	5.6	153	-180	1431	0.7	179	628	698
11	99.9	0.083113	-4	-24 2356	608 405	-124 -64	257	140 0	679 826	163 51
31	0.251	10.01	6	164	-194	1425	0.7	171	620	661
12	99.9	0.090232	-20	-17 2356	588 387	-125 -63	271	143 16	684 818	168 51
31	0.25	10.01	6.6	179	-186	1420	0.7	192	668	818
13	100	0.10009	-43	-7 2173	580 372	-126 -64	305	156 675	787 974	182 57
31	0.251	10.01	7.2	196	-169	1406	0.7	203	737	945
14	99.9	0.11028	-61	4 2310	571 360	-127 -61	330	161 461	902 1094	201 67
31	0.251	10.01	7.8	214	-166	1397	0.5	213	747	1031
15	100	0.120413	-82	16 2332	554 302	-127 -56	365	170 488	952 1200	215 67
31	0.252	10.01	5.6	147	-160	1438	0.7	165	637	693
16	100.1	0.082877	-2	-27 2356	616 380	-124 -67	251	138 0	697 818	167 52

RUN POINT	V/OR VKTS	ALFS,U CTH/S	MRFLAP1 MRPR3 (MEAN)	MRNB1A MRNB2 MRNB3 (MEAN)	MREB1A MREB2 MREB3 (MEAN)	MREB4A MRNB7 MRNB9A (MEAN)	MRFLAP1 MRPR3 (1/2P-P)	MRNB1A MRNB2 MRNB3 (1/2P-P)	MREB1A MREB2 MREB3 (1/2P-P)	MREB4A MRNB7 MRNB9A (1/2P-P)
36	0.228	-10	4	169	71	1281	0.4	102	578	535
6	91.7	0.065467	-141	23 53	763 320	-43 5	231	71 75	532 611	126 43
36	0.251	-10	4	171	84	1278	0.6	119	599	615
7	100.6	0.065892	-148	26 55	770 322	-42 6	256	80 81	554 670	135 45
36	0.227	-10	4	167	65	1282	0.5	103	568	523
8	91.3	0.065317	-141	22 53	757 313	-42 5	237	70 75	522 599	125 42
36	0.201	-10	4	164	52	1275	0.4	82	547	439
9	80.2	0.065121	-131	20 50	742 307	-41 5	235	55 68	482 538	122 46
36	0.178	-10	4	163	45	1275	0.3	78	549	402
10	71.1	0.065184	-124	18 48	735 304	-37 6	243	45 65	487 511	120 51
36	0.151	-10	4	161	34	1278	0.4	84	546	419
11	60.4	0.064857	-117	15 45	728 300	-33 8	244	59 62	485 525	120 54
36	0.15	-10	4.1	161	35	1272	0.4	77	547	426
22	60.3	0.06513	-119	15 43	723 295	-33 8	235	62 63	489 523	123 56

RUN POINT	V/OR VKTS	ALFS,U CTH/S	MRFLAP1 MRPR3 (MEAN)	MRNB1A MRNB2 MRNB3 (MEAN)	MREB1A MREB2 MREB3 (MEAN)	MREB4A MRNB7 MRNB9A (MEAN)	MRFLAP1 MRPR3 (1/2P-P)	MRNB1A MRNB2 MRNB3 (1/2P-P)	MREB1A MREB2 MREB3 (1/2P-P)	MREB4A MRNB7 MRNB9A (1/2P-P)
36	0.124	-10	4.1	161	28	1268	0.4	81	562	436
23	50	0.065259	-119	14	717	-28	235	72	502	123
				42	292	14		63	533	64
36	0.101	-10	4	159	23	1258	0.5	81	563	426
24	40.5	0.064861	-125	12	712	-18	239	72	506	122
				41	285	22		64	523	72
36	0.091	-10	4	159	25	1249	0.5	78	559	438
25	36.6	0.065454	-130	12	711	-10	248	72	500	121
				41	282	27		68	524	73
36	0.081	-10	4	157	24	1239	0.5	73	575	463
26	32.6	0.065056	-136	11	708	0	238	63	519	117
				41	277	34		63	564	74
36	0.071	-10	4	156	24	1228	0.4	80	598	492
27	28.6	0.064757	-144	11	706	11	233	60	560	115
				43	270	41		56	611	79
36	0.061	-10	4	155	23	1209	0.5	83	591	467
28	24.3	0.064791	-155	11	701	23	215	60	564	114
				44	261	47		50	605	72
36	0.051	-10	4	158	25	1198	0.4	88	572	420
29	20.5	0.065376	-168	13	700	36	202	55	554	116
				47	250	55		47	552	69

RUN POINT	V/OR VKTS	ALFS,U CTH/S	MRFLAP1 MRPR3 (MEAN)	MRNB1A MRNB2 MRNB3 (MEAN)	MREB1A MREB2 MREB3 (MEAN)	MREB4A MRNB7 MRNB9A (MEAN)	MRFLAP1 MRPR3 (1/2P-P)	MRNB1A MRNB2 MRNB3 (1/2P-P)	MREB1A MREB2 MREB3 (1/2P-P)	MREB4A MRNB7 MRNB9A (1/2P-P)
36	0.042	-10	4	157	21	1179	0.3	99	538	374
30	16.7	0.064864	-178	13 49	693 237	46 62	184	55 37	489 506	114 69
36	0.031	-10	4	159	26	1174	0.3	92	395	240
31	12.3	0.065191	-186	16 51	695 235	47 72	149	51 33	328 306	90 60
36	0.021	-10	4	159	40	1196	0.3	62	275	203
32	8.5	0.064771	-183	15 51	713 253	34 73	194	38 30	242 239	75 48
36	0.006	-10	3.9	162	56	1215	0.6	107	152	227
33	2.4	0.064534	-190	17 51	728 296	34 72	93	85 64	198 237	104 67
51	0.25	-4.99	4	162	27	1252	0.4	98	539	516
5	100	0.064099	-64	6 25	729 337	-63 1	218	93 95	473 555	157 56
51	0.2	-4.99	4.1	164	11	1247	0.4	93	557	467
6	79.8	0.065135	-51	8 26	711 322	-58 1	230	72 79	518 581	142 64
51	0.15	-4.99	4.1	164	2	1245	0.4	102	584	535
7	60.1	0.065034	-47	7 25	706 318	-50 3	257	85 71	575 627	152 70

RUN POINT	V/OR VKTS	ALFS,U CTH/S	MRFLAP1 MRPR3 (MEAN)	MRNB1A MRNB2 MRNB3 (MEAN)	MREB1A MREB2 MREB3 (MEAN)	MREB4A MRNB7 MRNB9A (MEAN)	MRFLAP1 MRPR3 (1/2P-P)	MRNB1A MRNB2 MRNB3 (1/2P-P)	MREB1A MREB2 MREB3 (1/2P-P)	MREB4A MRNB7 MRNB9A (1/2P-P)
51	0.125	-4.99	4.1	163	7	1245	0.6	110	626	569
8	49.8	0.064797	-49	6 26	710 319	-44 7	270	97 84	632 655	155 73
51	0.101	-4.99	4.1	164	14	1237	0.6	163	643	585
9	40.2	0.064748	-58	6 27	713 317	-33 15	269	125 104	657 681	162 76
51	0.091	-4.99	4	164	19	1231	0.6	152	650	582
10	36.4	0.06462	-63	7 27	715 316	-25 20	272	132 105	662 700	160 80
51	0.081	-4.99	4	165	24	1224	0.7	148	649	586
11	32.3	0.064971	-71	8 29	716 310	-14 26	261	131 106	640 710	162 86
51	0.071	-4.99	4	166	28	1210	0.7	120	645	595
12	28.3	0.065143	-81	9 32	716 302	-1 32	268	110 99	609 702	158 86
51	0.06	-4.99	4	164	27	1187	0.6	137	644	547
13	24	0.065047	-97	10 34	710 288	17 42	245	113 85	646 711	154 84
51	0.05	-4.99	4	164	27	1162	0.6	103	632	552
14	20.1	0.064704	-111	11 37	704 271	34 50	240	85 69	627 687	141 79

RUN POINT	V/OR VKTS	ALFS,U CTH/S	MRFLAP1 MRPR3 (MEAN)	MRNB1A MRNB2 MRNB3 (MEAN)	MREB1A MREB2 MREB3 (MEAN)	MREB4A MRNB7 MRNB9A (MEAN)	MRFLAP1 MRPR3 (1/2P-P)	MRNB1A MRNB2 MRNB3 (1/2P-P)	MREB1A MREB2 MREB3 (1/2P-P)	MREB4A MRNB7 MRNB9A (1/2P-P)
51	0.041	-4.99	4	165	23	1137	0.5	97	566	420
15	16.3	0.064964	-130	14	695	55	208	64	547	128
				41	248	60		48	561	70
51	0.029	-4.99	4	165	19	1127	0.3	108	474	267
16	11.8	0.064603	-139	16	689	57	159	59	384	117
				44	238	69		34	371	62
51	0.02	-4.99	4	167	35	1167	0.4	82	304	177
17	7.9	0.065017	-139	16	712	37	113	48	245	78
				43	266	76		40	234	54
51	0.011	-4.99	3.9	167	69	1191	0.5	172	250	274
18	4.5	0.064533	-135	14	741	31	112	117	286	112
				41	299	73		72	268	59
32	0.252	-2	4.2	152	-14	1346	0.4	111	570	582
7	100.5	0.065272	-96	-3	704	-75	192	93	544	162
				20	369	-3		105	612	74
32	0.201	-2	4.2	154	-20	1336	0.4	127	541	530
8	80.3	0.065939	-84	-1	691	-69	391	84	522	141
				22	362	-2		82	603	82
32	0.15	-2	4.2	155	-15	1332	0.4	86	575	478
9	60.1	0.065799	-84	0	694	-58	233	69	549	131
				24	359	0		68	587	56

RUN POINT	V/OR VKTS	ALFS,U CTH/S	MRFLAP1 MRPR3 (MEAN)	MRNB1A MRNB2 MRNB3 (MEAN)	MREB1A MREB2 MREB3 (MEAN)	MREB4A MRNB7 MRNB9A (MEAN)	MRFLAP1 MRPR3 (1/2P-P)	MRNB1A MRNB2 MRNB3 (1/2P-P)	MREB1A MREB2 MREB3 (1/2P-P)	MREB4A MRNB7 MRNB9A (1/2P-P)
32	0.125	-2	4.1	155	-2	1322	0.5	114	582	505
10	50.1	0.065132	-87	0	701	-51	241	96	552	139
				26	357	2		81	595	66
32	0.1	-2	4.1	157	11	1310	0.6	176	657	597
11	40.2	0.065072	-97	2	706	-42	248	144	664	161
				28	335	8		111	670	86
32	0.08	-2	4.1	161	21	1285	0.7	203	699	677
12	32	0.065374	-109	6	705	-27	252	174	756	190
				34	323	18		142	793	103
32	0.061	-2	4.1	161	30	1255	0.8	159	689	683
13	24.3	0.065427	-138	9	706	4	264	144	704	183
				41	300	36		119	826	95
32	0.05	-2	4.1	161	25	1223	0.7	133	654	600
14	20.1	0.065203	-157	12	696	31	247	112	652	166
				45	280	47		88	739	88
32	0.04	-2	4.1	164	23	1196	0.4	120	599	450
15	16	0.06572	-180	15	688	57	206	80	605	135
				51	260	59		59	587	75
32	0.03	-2	4.1	162	9	1178	0.4	97	519	330
16	12.1	0.065522	-195	17	674	63	161	55	458	124
				53	243	69		39	448	62

RUN POINT	V/OR VKTS	ALFS,U CTH/S	MRFLAP1 MRPR3 (MEAN)	MRNB1A MRNB2 MRNB3 (MEAN)	MREB1A MREB2 MREB3 (MEAN)	MREB4A MRNB7 MRNB9A (MEAN)	MRFLAP1 MRPR3 (1/2P-P)	MRNB1A MRNB2 MRNB3 (1/2P-P)	MREB1A MREB2 MREB3 (1/2P-P)	MREB4A MRNB7 MRNB9A (1/2P-P)
32	0.02	-2	4	162	31	1221	0.4	77	332	207
17	8.1	0.065334	-194	15	702	37	194	47	291	82
				52	267	73		42	269	55
32	0.011	-2	4.1	176	70	1235	0.6	138	210	234
18	4.2	0.068691	-195	26	727	31	113	109	286	102
				57	274	73		72	296	65
32	0	-2	4	163	42	1215	0.8	148	269	342
19	0	0.065556	-200	18	706	43	104	115	335	144
				59	239	81		95	343	87
34	0.251	-2	4.2	158	7	1322	0.5	111	583	594
5	99.7	0.065585	-81	-3	727	-75	200	92	574	164
				47	385	-3		110	629	76
34	0.22	-2	4.2	157	-1	1311	0.4	98	566	550
6	87.3	0.065619	-78	-3	715	-73	214	85	525	143
				45	374	-2		94	605	75
34	0.198	-2	4.2	157	-5	1311	0.4	116	550	558
7	78.5	0.065069	-74	-2	710	-69	225	83	523	142
				45	372	-2		84	626	81
34	0.174	-2	4.2	158	0	1307	0.4	68	558	504
8	69	0.065435	-74	-1	710	-63	241	47	519	125
				46	364	-1		68	583	60

RUN POINT	V/OR VKTS	ALFS,U CTH/S	MRFLAP1 MRPR3 (MEAN)	MRNB1A MRNB2 MRNB3 (MEAN)	MREB1A MREB2 MREB3 (MEAN)	MREB4A MRNB7 MRNB9A (MEAN)	MRFLAP1 MRPR3 (1/2P-P)	MRNB1A MRNB2 MRNB3 (1/2P-P)	MREB1A MREB2 MREB3 (1/2P-P)	MREB4A MRNB7 MRNB9A (1/2P-P)
34	0.152	-2	4.2	159	9	1309	0.3	77	580	492
9	60.5	0.06518	-74	-1 47	717 366	-58 0	236	66 70	565 608	130 53
34	0.124	-2	4.3	161	21	1298	0.5	119	604	534
10	49.2	0.065688	-80	0 49	721 364	-51 3	261	100 86	578 605	140 68
34	0.102	-2	4.2	163	31	1294	0.5	186	646	604
11	40.7	0.065487	-86	2 51	729 352	-43 8	261	146 112	664 668	161 86
34	0.092	-2	4.2	162	35	1284	0.7	197	668	638
12	36.8	0.064849	-91	3 53	729 346	-37 12	249	164 129	687 721	176 99
34	0.082	-2	4.2	165	44	1271	0.8	197	694	674
13	32.8	0.065432	-101	5 57	732 351	-28 18	247	173 143	741 774	188 104
34	0.072	-2	4.1	165	47	1262	0.8	185	700	670
14	28.8	0.06496	-111	6 58	734 346	-18 25	261	168 140	741 807	193 105
34	0.061	-2	4.1	165	51	1235	0.7	163	692	670
15	24.5	0.065022	-129	8 63	731 324	3 36	260	145 123	698 820	189 98

RUN POINT	V/OR VKTS	ALFS,U CTH/S	MRFLAP1 MRPR3 (MEAN)	MRNB1A MRNB2 MRNB3 (MEAN)	MREB1A MREB2 MREB3 (MEAN)	MREB4A MRNB7 MRNB9A (MEAN)	MRFLAP1 MRPR3 (1/2P-P)	MRNB1A MRNB2 MRNB3 (1/2P-P)	MREB1A MREB2 MREB3 (1/2P-P)	MREB4A MRNB7 MRNB9A (1/2P-P)
34	0.053	-2	4.1	164	48	1208	0.7	144	653	593
16	20.9	0.065025	-148	11	723	27	242	121	658	172
				66	304	45		98	750	95
34	0.042	-2	4.1	164	45	1180	0.4	127	603	484
17	16.8	0.064817	-169	13	716	53	211	95	608	144
				71	283	56		66	626	81
34	0.032	-2	4.1	165	37	1155	0.4	100	526	321
18	12.9	0.06507	-187	16	704	65	178	53	469	128
				75	261	69		40	459	63
38	0.25	5	4.3	142	-80	1373	0.7	147	530	542
5	99.7	0.064728	-24	-25	679	-104	192	124	552	144
				-6	411	-11		133	611	44
38	0.224	5	4.3	147	-73	1364	0.6	140	489	498
6	89.3	0.06487	-25	-21	679	-102	195	105	483	132
				-2	405	-10		109	600	54
38	0.198	5	4.3	150	-57	1359	0.5	96	429	441
7	79	0.06486	-26	-18	686	-97	189	84	423	115
				0	402	-8		89	516	44
38	0.174	5	4.3	150	-52	1343	0.5	73	427	383
8	69.2	0.064755	-32	-16	682	-91	218	63	409	106
				2	394	-7		70	476	42

RUN POINT	V/OR VKTS	ALFS,U CTH/S	MRFLAP1 MRPR3 (MEAN)	MRNB1A MRNB2 MRNB3 (MEAN)	MREB1A MREB2 MREB3 (MEAN)	MREB4A MRNB7 MRNB9A (MEAN)	MRFLAP1 MRPR3 (1/2P-P)	MRNB1A MRNB2 MRNB3 (1/2P-P)	MREB1A MREB2 MREB3 (1/2P-P)	MREB4A MRNB7 MRNB9A (1/2P-P)
38	0.151	5	4.3	151	-49	1337	0.5	82	474	349
9	60.3	0.065069	-40	-15	683	-85	212	65	426	99
				5	387	-7		62	440	49
38	0.151	5	4.3	150	-53	1335	0.5	79	474	347
10	60.3	0.06509	-40	-16	680	-85	211	66	426	99
				5	383	-7		65	435	49
38	0.125	5	4.3	149	-20	1327	0.5	94	496	334
11	49.9	0.06502	-49	-15	699	-76	215	74	435	111
				7	395	-4		68	399	46
38	0.101	5	4.2	147	-11	1315	0.5	174	515	323
12	40.5	0.065354	-68	-16	711	-62	229	109	416	126
				9	395	0		96	395	82
38	0.09	5	4.2	146	3	1296	0.6	191	548	331
13	35.9	0.065745	-80	-14	716	-53	239	134	452	144
				14	384	2		114	434	77
38	0.081	5	4.2	147	18	1284	0.6	244	588	393
14	32.5	0.065004	-87	-12	724	-47	258	201	513	183
				17	385	5		136	526	82
38	0.071	5	4.2	151	39	1284	0.7	288	603	522
15	28.4	0.064612	-101	-9	743	-39	265	231	644	218
				23	378	10		172	670	97

RUN POINT	V/OR VKTS	ALFS,U CTH/S	MRFLAP1 MRPR3 (MEAN)	MRNB1A MRNB2 MRNB3 (MEAN)	MREB1A MREB2 MREB3 (MEAN)	MREB4A MRNB7 MRNB9A (MEAN)	MRFLAP1 MRPR3 (1/2P-P)	MRNB1A MRNB2 MRNB3 (1/2P-P)	MREB1A MREB2 MREB3 (1/2P-P)	MREB4A MRNB7 MRNB9A (1/2P-P)
38	0.06	5	4.2	158	54	1279	0.9	334	685	771
16	24.1	0.065144	-121	1	737	-27	266	260	753	271
				33	366	17		195	807	124
38	0.052	5	4.1	161	44	1231	0.8	244	677	770
17	20.6	0.065297	-144	8	719	-4	256	220	717	268
				43	329	29		175	817	113
38	0.042	5	4.1	165	46	1187	0.7	176	643	649
18	16.8	0.064951	-173	15	709	42	239	142	689	206
				51	286	44		106	754	101
38	0.031	5	4.1	165	38	1151	0.4	135	554	361
19	12.4	0.065062	-204	19	692	73	198	83	526	134
				55	256	63		58	503	73
38	0.021	5	4.1	164	39	1169	0.4	106	448	253
20	8.4	0.065404	-207	18	698	55	145	63	363	125
				54	270	68		42	327	61
38	0.01	5	4.1	182	107	1201	0.6	143	291	317
21	3.8	0.065216	-207	31	751	34	117	104	297	133
				67	308	75		86	349	72
37	0.251	-10	4.7	200	118	1261	0.7	141	634	703
5	100.3	0.08011	-169	49	784	-45	281	95	632	158
				64	336	9		95	779	54

RUN POINT	V/OR VKTS	ALFS,U CTH/S	MRFLAP1 MRPR3 (MEAN)	MRNB1A MRNB2 MRNB3 (MEAN)	MREB1A MREB2 MREB3 (MEAN)	MREB4A MRNB7 MRNB9A (MEAN)	MRFLAP1 MRPR3 (1/2P-P)	MRNB1A MRNB2 MRNB3 (1/2P-P)	MREB1A MREB2 MREB3 (1/2P-P)	MREB4A MRNB7 MRNB9A (1/2P-P)
37	0.2	-10	4.8	194	87	1261	0.5	109	582	563
6	80	0.080654	-151	45 59	752 319	-41 8	276	67 78	552 676	140 55
37	0.15	-10	4.9	195	71	1268	0.6	103	598	505
7	60.1	0.081279	-142	41 55	742 314	-29 14	296	78 74	536 589	140 70
37	0.1	-10	4.8	190	49	1244	0.6	100	588	489
8	40.3	0.080223	-152	37 52	726 298	-8 33	290	75 69	522 571	146 85
37	0.091	-10	4.8	189	47	1234	0.6	100	583	463
9	36.4	0.079761	-158	36 52	722 290	2 39	282	70 71	519 561	142 90
37	0.081	-10	4.8	187	40	1218	0.6	103	595	491
10	32.3	0.08008	-168	35 53	714 280	16 47	280	64 62	544 580	132 92
37	0.071	-10	4.8	185	35	1201	0.5	96	602	513
11	28.4	0.079829	-177	35 53	707 268	29 54	271	65 59	564 609	128 93
37	0.06	-10	4.8	185	33	1178	0.5	100	613	507
12	23.9	0.080131	-189	36 55	700 255	43 61	262	59 48	574 615	132 85

RUN POINT	V/OR VKTS	ALFS,U CTH/S	MRFLAP1 MRPR3 (MEAN)	MRNB1A MRNB2 MRNB3 (MEAN)	MREB1A MREB2 MREB3 (MEAN)	MREB4A MRNB7 MRNB9A (MEAN)	MRFLAP1 MRPR3 (1/2P-P)	MRNB1A MRNB2 MRNB3 (1/2P-P)	MREB1A MREB2 MREB3 (1/2P-P)	MREB4A MRNB7 MRNB9A (1/2P-P)
37	0.05	-10	4.8	187	32	1155	0.4	108	618	490
13	20.1	0.080587	-201	38	693	55	247	59	595	126
				58	239	67		47	626	82
37	0.041	-10	4.8	186	31	1137	0.3	131	580	429
14	16.3	0.079803	-210	39	687	64	221	71	547	126
				61	226	74		39	551	76
37	0.029	-10	4.7	185	44	1143	0.3	98	515	315
15	11.7	0.079412	-207	39	698	58	184	49	438	95
				61	238	84		34	419	61
37	0.019	-10	4.7	191	71	1179	0.4	91	422	251
16	7.7	0.080282	-202	40	727	46	156	61	347	91
				62	267	82		33	325	52
37	0.011	-10	4.8	199	84	1205	0.7	144	403	369
17	4.6	0.079897	-206	45	739	41	131	98	358	98
				62	286	82		88	401	65
37	0.011	-10	4.8	200	99	1203	0.5	116	263	327
18	4.6	0.081746	-205	46	750	45	115	91	282	97
				64	286	85		87	290	64
53	0.25	-5	4.8	197	59	1220	0.5	129	576	595
5	100.1	0.0794	-101	31	742	-69	265	104	580	166
				49	330	4		101	700	70

RUN POINT	V/OR VKTS	ALFS,U CTH/S	MRFLAP1 MRPR3 (MEAN)	MRNB1A MRNB2 MRNB3 (MEAN)	MREB1A MREB2 MREB3 (MEAN)	MREB4A MRNB7 MRNB9A (MEAN)	MRFLAP1 MRPR3 (1/2P-P)	MRNB1A MRNB2 MRNB3 (1/2P-P)	MREB1A MREB2 MREB3 (1/2P-P)	MREB4A MRNB7 MRNB9A (1/2P-P)
53	0.227	-5	4.8	194	45	1217	0.5	111	571	560
6	90.9	0.079473	-94	29 52	726 323	-67 4	260	97 92	537 635	156 66
53	0.2	-5	4.9	197	39	1218	0.5	110	587	559
7	80	0.080382	-89	31 48	717 311	-62 5	281	89 85	543 639	160 77
53	0.176	-5	4.9	196	31	1218	0.5	123	592	596
8	70.7	0.079678	-83	29 44	715 313	-57 5	299	90 78	566 661	170 81
53	0.15	-5	4.9	197	31	1210	0.6	139	626	640
9	60.2	0.079517	-83	30 46	712 313	-51 8	305	114 87	643 716	171 90
53	0.125	-5	4.9	198	33	1207	0.7	151	672	667
10	49.9	0.07991	-89	30 45	713 310	-44 14	316	130 110	699 748	172 100
53	0.096	-5	4.7	196	35	1185	0.8	171	678	640
12	38.5	0.079179	-108	29 47	713 301	-21 30	299	147 117	707 743	179 97
53	0.091	-5	4.8	199	38	1179	0.8	171	682	660
13	36.6	0.079765	-110	31 49	711 298	-19 31	312	147 119	715 754	181 98

RUN POINT	V/OR VKTS	ALFS,U CTH/S	MRFLAP1 MRPR3 (MEAN)	MRNB1A MRNB2 MRNB3 (MEAN)	MREB1A MREB2 MREB3 (MEAN)	MREB4A MRNB7 MRNB9A (MEAN)	MRFLAP1 MRPR3 (1/2P-P)	MRNB1A MRNB2 MRNB3 (1/2P-P)	MREB1A MREB2 MREB3 (1/2P-P)	MREB4A MRNB7 MRNB9A (1/2P-P)
53	0.08	-5	4.8	199	36	1170	0.8	147	668	673
14	32.2	0.079733	-123	31	709	4	300	130	672	169
				49	287	39		110	768	96
53	0.07	-5	4.8	198	31	1148	0.7	158	664	656
15	28.3	0.079576	-135	32	701	11	295	127	666	165
				50	271	47		111	771	94
53	0.06	-5	4.8	198	33	1128	0.7	119	647	617
16	24	0.079684	-153	33	701	30	293	104	610	158
				53	254	56		89	697	95
53	0.051	-5	4.8	198	35	1094	0.5	111	663	621
17	20.3	0.079614	-168	36	692	47	277	77	657	146
				57	235	64		65	742	87
53	0.041	-5	4.8	200	29	1072	0.4	112	630	520
18	16.3	0.079979	-185	38	682	66	234	60	615	137
				61	210	74		46	654	75
53	0.029	-5	4.7	200	51	1086	0.3	116	536	341
19	11.8	0.0799	-185	40	699	54	205	62	483	100
				62	232	82		37	457	64
53	0.021	-5	4.7	205	94	1134	0.4	101	479	297
20	8.2	0.079883	-178	41	741	38	159	55	374	112
				62	274	84		45	337	57

RUN POINT	V/OR VKTS	ALFS,U CTH/S	MRFLAP1 MRPR3 (MEAN)	MRNB1A MRNB2 MRNB3 (MEAN)	MREB1A MREB2 MREB3 (MEAN)	MREB4A MRNB7 MRNB9A (MEAN)	MRFLAP1 MRPR3 (1/2P-P)	MRNB1A MRNB2 MRNB3 (1/2P-P)	MREB1A MREB2 MREB3 (1/2P-P)	MREB4A MRNB7 MRNB9A (1/2P-P)
53	0.014	-5	4.6	211	117	1162	0.5	154	350	319
21	5.7	0.079123	-172	43	764	26	160	108	339	117
				63	294	81		80	354	73
32	0	-2	4.7	203	98	1228	1	188	489	540
20	0	0.080324	-233	45	734	52	154	168	488	161
				189	210	89		247	486	91
32	0.02	-2	4.8	197	60	1204	0.4	119	501	380
21	8.1	0.080711	-221	38	705	51	174	66	445	108
				245	173	88		51	460	62
32	0.04	-2	4.9	195	24	1142	0.4	114	654	552
22	16.1	0.080631	-205	37	659	78	256	72	639	152
				246	123	74		55	686	79
32	0.04	-2	4.9	195	23	1140	0.4	113	655	567
23	16.1	0.080698	-198	38	654	78	256	72	644	151
				243	126	75		56	705	78
32	0.06	-2	4.9	192	28	1202	0.8	164	702	735
24	24	0.080626	-145	32	668	25	296	141	706	206
				224	168	54		121	821	103
32	0.08	-2	4.9	193	24	1225	0.8	205	749	835
25	32	0.080393	-107	28	679	-15	303	179	800	220
				222	214	34		149	881	112

RUN POINT	V/OR VKTS	ALFS,U CTH/S	MRFLAP1 MRPR3 (MEAN)	MRNB1A MRNB2 MRNB3 (MEAN)	MREB1A MREB2 MREB3 (MEAN)	MREB4A MRNB7 MRNB9A (MEAN)	MRFLAP1 MRPR3 (1/2P-P)	MRNB1A MRNB2 MRNB3 (1/2P-P)	MREB1A MREB2 MREB3 (1/2P-P)	MREB4A MRNB7 MRNB9A (1/2P-P)
32	0.1	-2	5	191	13	1253	0.7	248	737	773
26	40	0.079896	-87	24	676	-36	288	182	805	204
				108	224	20		143	836	115
32	0.125	-2	5	185	-2	1266	0.6	155	675	640
27	50.1	0.080465	-86	19	670	-50	291	124	695	164
				248	226	12		102	704	87
32	0.201	-2	5	178	-13	1280	0.4	140	574	515
28	80.4	0.079693	-76	16	664	-72	267	95	545	162
				201	235	5		93	600	101
32	0.251	-2	5	178	-7	1288	0.4	131	578	615
29	100.1	0.08008	-85	16	673	-80	257	99	555	174
				156	250	3		111	625	93
32	0.1	-2	5	192	20	1253	0.8	242	738	795
30	40	0.080408	-114	25	682	-34	297	181	815	203
				156	225	21		140	860	113
32	0.08	-2	4.9	193	32	1218	0.8	195	740	820
31	32.1	0.080297	-139	28	681	-13	316	174	787	215
				161	213	36		145	878	109
32	0.03	-2	4.8	195	36	1124	0.4	127	540	387
32	12.2	0.079146	-226	38	670	73	205	70	483	129
				179	144	85		39	492	69

RUN POINT	V/OR VKTS	ALFS,U CTH/S	MRFLAP1 MRPR3 (MEAN)	MRNB1A MRNB2 MRNB3 (MEAN)	MREB1A MREB2 MREB3 (MEAN)	MREB4A MRNB7 MRNB9A (MEAN)	MRFLAP1 MRPR3 (1/2P-P)	MRNB1A MRNB2 MRNB3 (1/2P-P)	MREB1A MREB2 MREB3 (1/2P-P)	MREB4A MRNB7 MRNB9A (1/2P-P)
35	0.251	-2.01	5.1	175	25	1318	0.5	125	583	634
5	99.4	0.0804	-117	15	724	-81	254	99	564	177
				23	385	-1		118	649	94
35	0.222	-2.01	5.1	174	24	1312	0.4	125	570	547
6	88.2	0.080721	-110	14	719	-79	257	96	512	162
				22	379	-1		92	600	91
35	0.198	-2.01	5.1	174	19	1314	0.4	175	588	533
7	78.7	0.080072	-108	15	712	-73	280	103	576	164
				21	378	-1		91	618	100
35	0.173	-2.01	5.1	175	20	1308	0.4	94	597	519
8	68.7	0.080128	-106	16	709	-65	288	73	592	150
				21	371	-1		74	606	80
35	0.151	-2.01	5.1	175	24	1302	0.5	107	627	560
9	60.1	0.079704	-107	16	711	-60	280	90	618	158
				20	371	1		81	663	73
35	0.125	-2.01	5.1	179	29	1297	0.6	168	678	642
10	49.8	0.080296	-115	18	715	-51	289	119	693	167
				25	367	6		103	717	90
35	0.102	-2.01	5	183	41	1280	0.7	242	721	776
11	40.4	0.080298	-124	21	719	-38	290	179	795	200
				28	358	14		142	845	112

RUN POINT	V/OR VKTS	ALFS,U CTH/S	MRFLAP1 MRPR3 (MEAN)	MRNB1A MRNB2 MRNB3 (MEAN)	MREB1A MREB2 MREB3 (MEAN)	MREB4A MRNB7 MRNB9A (MEAN)	MRFLAP1 MRPR3 (1/2P-P)	MRNB1A MRNB2 MRNB3 (1/2P-P)	MREB1A MREB2 MREB3 (1/2P-P)	MREB4A MRNB7 MRNB9A (1/2P-P)
35	0.092	-2.01	5	185	48	1266	0.8	237	742	820
12	36.4	0.08061	-134	25	719	-29	301	190	843	212
				32	349	19		157	891	114
35	0.082	-2.01	5	184	53	1257	0.9	205	740	826
13	32.8	0.079749	-143	25	723	-19	312	187	812	219
				34	347	26		152	889	113
35	0.072	-2.01	5	187	57	1234	0.8	208	733	855
14	28.6	0.080315	-160	28	721	-2	297	165	796	216
				38	333	38		144	916	113
35	0.061	-2.01	5	186	59	1198	0.8	171	699	750
15	24.2	0.080489	-179	30	714	24	288	147	738	209
				43	308	50		126	839	105
35	0.052	-2.01	4.9	185	54	1163	0.6	146	648	687
16	20.5	0.079695	-196	32	704	49	284	114	635	185
				46	273	57		96	740	105
35	0.042	-2.01	4.9	185	55	1129	0.4	119	672	583
17	16.5	0.080049	-214	35	695	73	257	80	673	162
				50	247	68		59	734	85
35	0.031	-2.01	4.9	185	57	1125	0.4	129	549	400
18	12.4	0.079912	-226	37	694	76	209	74	498	137
				52	243	78		40	521	72

RUN POINT	V/OR VKTS	ALFS,U CTH/S	MRFLAP1 MRPR3 (MEAN)	MRNB1A MRNB2 MRNB3 (MEAN)	MREB1A MREB2 MREB3 (MEAN)	MREB4A MRNB7 MRNB9A (MEAN)	MRFLAP1 MRPR3 (1/2P-P)	MRNB1A MRNB2 MRNB3 (1/2P-P)	MREB1A MREB2 MREB3 (1/2P-P)	MREB4A MRNB7 MRNB9A (1/2P-P)
35	0.031	-2.01	4.9	185	55	1122	0.4	128	552	401
19	12.3	0.080014	-226	37	692	77	211	70	504	138
				53	240	78		39	519	72
48	0.013	0	4.8	211	117	1204	0.9	179	359	468
5	5.2	0.080247	-241	44	775	45	146	125	373	141
				56	319	88		174	458	73
48	0.021	0	4.8	205	93	1182	0.6	111	538	357
6	8.4	0.082654	-240	42	751	51	183	69	497	115
				67	289	82		267	481	63
48	0.031	0	5	207	61	1116	0.4	142	567	422
7	12.3	0.083695	-245	45	706	82	219	79	523	143
				70	231	79		180	546	72
48	0.04	0	4.9	197	51	1110	0.4	134	658	563
8	16	0.080305	-228	38	699	80	249	83	664	161
				56	228	68		192	699	82
48	0.05	0	4.8	195	47	1150	0.6	169	669	721
9	20.1	0.079955	-207	34	708	51	285	130	651	202
				37	257	56		120	769	111
48	0.061	0	4.9	195	54	1181	0.8	200	734	909
10	24.3	0.080292	-180	31	715	11	307	175	773	235
				31	283	44		164	928	111

RUN POINT	V/OR VKTS	ALFS,U CTH/S	MRFLAP1 MRPR3 (MEAN)	MRNB1A MRNB2 MRNB3 (MEAN)	MREB1A MREB2 MREB3 (MEAN)	MREB4A MRNB7 MRNB9A (MEAN)	MRFLAP1 MRPR3 (1/2P-P)	MRNB1A MRNB2 MRNB3 (1/2P-P)	MREB1A MREB2 MREB3 (1/2P-P)	MREB4A MRNB7 MRNB9A (1/2P-P)
48	0.071	0	4.9	193	49	1220	0.8	219	776	914
11	28.6	0.079774	-157	26 23	725 300	-13 31	299	200 169	844 942	240 126
48	0.091	0	5	190	39	1253	0.7	288	771	861
12	36.5	0.079953	-133	20 13	725 329	-34 14	319	222 167	870 869	217 126
48	0.1	0	5	185	36	1264	0.6	303	756	773
13	40	0.079907	-124	16 9	727 340	-42 10	290	215 148	848 840	208 126
48	0.124	0.02	5	180	21	1273	0.5	145	632	559
14	49.6	0.080033	-111	12 4	716 354	-54 2	280	107 101	599 603	158 90
48	0.15	0	5.1	181	5	1287	0.4	126	594	529
15	59.9	0.079852	-102	12 1	705 357	-63 -1	274	80 78	562 660	156 98
48	0.2	0	5.1	176	-15	1294	0.4	153	605	604
16	79.9	0.079954	-97	10 0	695 349	-82 -4	261	102 94	621 615	156 100
48	0.251	0	5.1	174	-13	1274	0.5	125	575	629
17	100.1	0.079969	-103	8 -1	694 345	-87 -5	229	117 115	535 704	176 87

RUN POINT	V/OR VKTS	ALFS,U CTH/S	MRFLAP1 MRPR3 (MEAN)	MRNB1A MRNB2 MRNB3 (MEAN)	MREB1A MREB2 MREB3 (MEAN)	MREB4A MRNB7 MRNB9A (MEAN)	MRFLAP1 MRPR3 (1/2P-P)	MRNB1A MRNB2 MRNB3 (1/2P-P)	MREB1A MREB2 MREB3 (1/2P-P)	MREB4A MRNB7 MRNB9A (1/2P-P)
48	0.251	0	5.1	174	-12	1274	0.4	127	576	627
18	100.1	0.07979	-102	8	694	-87	230	116	538	175
				-1	346	-5		112	696	87
48	0.2	0	5.1	177	-13	1282	0.4	163	604	599
19	79.9	0.080118	-101	11	691	-81	261	104	617	156
				1	346	-3		94	615	100
48	0.151	0	5.1	181	6	1281	0.4	130	589	545
20	60.4	0.080085	-104	12	705	-63	268	80	554	158
				3	355	-1		79	674	91
48	0.125	0	5	180	21	1261	0.5	139	633	556
21	50.1	0.07986	-114	12	714	-54	278	105	607	160
				5	351	3		92	600	88
48	0.102	0	5	185	39	1248	0.7	271	767	762
22	40.7	0.079959	-128	17	723	-43	296	195	858	202
				11	329	10		140	821	118
48	0.102	0	5	185	35	1249	0.6	279	762	751
23	40.7	0.079748	-126	16	720	-43	302	200	850	202
				10	323	10		144	819	117
48	0.091	0	4.9	188	43	1241	0.9	284	770	855
24	36.5	0.079583	-135	20	720	-34	304	217	859	215
				13	317	15		165	864	126

RUN POINT	V/OR VKTS	ALFS,U CTH/S	MRFLAP1 MRPR3 (MEAN)	MRNB1A MRNB2 MRNB3 (MEAN)	MREB1A MREB2 MREB3 (MEAN)	MREB4A MRNB7 MRNB9A (MEAN)	MRFLAP1 MRPR3 (1/2P-P)	MRNB1A MRNB2 MRNB3 (1/2P-P)	MREB1A MREB2 MREB3 (1/2P-P)	MREB4A MRNB7 MRNB9A (1/2P-P)
48	0.071	0	4.9	195	52	1192	0.9	223	780	937
25	28.2	0.08	-164	28	715	-12	306	196	857	241
				24	286	33		169	969	127
48	0.061	0	4.9	194	55	1162	0.9	193	737	893
26	24.4	0.07937	-184	30	711	12	304	165	781	232
				29	270	44		148	919	114
48	0.051	0	4.9	194	47	1122	0.7	180	683	738
27	20.4	0.079627	-209	33	697	49	298	140	693	197
				34	236	56		107	805	107
48	0.041	0	4.9	195	45	1078	0.4	120	661	566
28	16.4	0.0794	-231	37	682	78	250	76	663	157
				40	207	69		57	709	78
48	0.031	0	4.9	198	49	1079	0.3	133	548	413
29	12.4	0.080542	-241	40	683	77	207	74	486	142
				42	211	77		41	517	73
48	0.021	0	4.8	195	72	1132	0.4	132	484	317
30	8.4	0.08018	-238	37	717	49	160	78	385	104
				40	257	82		46	341	61
48	0.012	0	4.7	207	110	1166	0.8	162	334	444
31	4.8	0.0812	-240	46	748	42	118	109	399	113
				43	280	83		90	433	69

RUN POINT	V/OR VKTS	ALFS,U CTH/S	MRFLAP1 MRPR3 (MEAN)	MRNB1A MRNB2 MRNB3 (MEAN)	MREB1A MREB2 MREB3 (MEAN)	MREB4A MRNB7 MRNB9A (MEAN)	MRFLAP1 MRPR3 (1/2P-P)	MRNB1A MRNB2 MRNB3 (1/2P-P)	MREB1A MREB2 MREB3 (1/2P-P)	MREB4A MRNB7 MRNB9A (1/2P-P)
39	0.25	5	5.2	161	-96	1359	0.7	178	569	653
6	99.3	0.079999	-54	-10	654	-109	237	137	638	161
				-9	380	-8		140	764	60
39	0.223	5	5.2	166	-78	1363	0.5	129	573	642
7	89	0.080227	-55	-5	666	-107	235	106	593	143
				-6	384	-8		118	704	67
39	0.198	5	5.2	168	-71	1361	0.5	97	536	530
8	78.9	0.080578	-53	-2	669	-101	231	79	510	131
				-3	380	-7		96	598	58
39	0.174	5	5.2	170	-51	1358	0.6	147	563	493
9	69.3	0.080605	-55	0	678	-94	233	93	512	131
				-2	384	-6		75	557	66
39	0.151	5	5.1	170	-38	1356	0.4	113	562	451
10	60.1	0.080486	-59	0	689	-88	233	81	497	131
				0	389	-5		73	493	64
39	0.124	5	5.1	168	-16	1358	0.5	179	582	456
11	49.7	0.079896	-74	-2	711	-74	223	99	545	141
				0	402	0		81	571	95
39	0.101	5	5	167	14	1325	0.5	239	600	484
12	40.3	0.080237	-95	-2	732	-58	269	140	567	176
				5	401	4		118	596	118

RUN POINT	V/OR VKTS	ALFS,U CTH/S	MRFLAP1 MRPR3 (MEAN)	MRNB1A MRNB2 MRNB3 (MEAN)	MREB1A MREB2 MREB3 (MEAN)	MREB4A MRNB7 MRNB9A (MEAN)	MRFLAP1 MRPR3 (1/2P-P)	MRNB1A MRNB2 MRNB3 (1/2P-P)	MREB1A MREB2 MREB3 (1/2P-P)	MREB4A MRNB7 MRNB9A (1/2P-P)
39	0.091	5	5	168	40	1305	0.7	296	627	569
13	36.3	0.080503	-102	2	743	-51	353	216	658	199
				11	402	8		154	695	105
39	0.081	5	5	171	48	1297	0.8	412	714	750
14	32.3	0.080979	-118	5	751	-43	311	304	800	256
				18	387	12		185	831	103
39	0.071	5	5	178	64	1297	0.9	392	762	921
15	28.3	0.080346	-128	15	748	-34	317	303	823	299
				25	362	19		219	1030	130
39	0.041	5	5	196	56	1127	0.5	202	693	682
16	16.2	0.081872	-217	42	692	81	279	130	723	203
				60	226	66		91	811	105
39	0.03	5	4.9	192	47	1135	0.4	122	616	513
17	12	0.080573	-235	40	694	90	248	74	586	149
				58	214	78		51	627	75
39	0.021	5	4.8	190	72	1186	0.4	144	550	418
18	8.2	0.08019	-227	38	727	58	204	84	473	126
				56	265	80		54	496	78
39	0.011	5	4.9	208	123	1207	0.7	213	278	420
19	4.2	0.08113	-231	51	763	43	127	173	338	156
				65	296	88		111	360	79

RUN POINT	V/OR VKTS	ALFS,U CTH/S	MRFLAP1 MRPR3 (MEAN)	MRNB1A MRNB2 MRNB3 (MEAN)	MREB1A MREB2 MREB3 (MEAN)	MREB4A MRNB7 MRNB9A (MEAN)	MRFLAP1 MRPR3 (1/2P-P)	MRNB1A MRNB2 MRNB3 (1/2P-P)	MREB1A MREB2 MREB3 (1/2P-P)	MREB4A MRNB7 MRNB9A (1/2P-P)
39	0.011	5	4.8	205	114	1214	0.7	165	300	469
20	4.2	0.081376	-233	50 62	757 294	49 88	132	125 104	373 417	128 80
41	0.252	10	5.6	163	-172	1369	0.7	172	621	683
5	100.1	0.083611	-18	-21 -26	585 338	-124 -11	286	141 152	679 811	160 55
41	0.23	10	5.5	165	-154	1378	0.7	163	603	642
6	91.6	0.081639	-13	-18 -23	603 347	-122 -11	263	132 128	642 739	150 49
41	0.2	10	5.3	166	-131	1383	0.6	137	586	582
7	80.1	0.079632	-15	-15 -20	622 356	-117 -9	241	108 108	613 710	124 39
41	0.179	10	5.3	169	-116	1367	0.6	101	584	554
8	71.1	0.080441	-22	-10 -16	624 354	-110 -8	237	91 90	583 655	109 44
41	0.151	10	5.3	171	-91	1362	0.7	81	562	441
9	60.2	0.080728	-36	-8 -10	643 355	-99 -6	235	76 83	551 563	93 41
41	0.125	10	5.2	168	-69	1349	0.6	153	535	391
10	49.8	0.08061	-49	-8 -9	657 360	-92 -4	210	124 101	481 496	102 52

RUN POINT	V/OR VKTS	ALFS,U CTH/S	MRFLAP1 MRPR3 (MEAN)	MRNB1A MRNB2 MRNB3 (MEAN)	MREB1A MREB2 MREB3 (MEAN)	MREB4A MRNB7 MRNB9A (MEAN)	MRFLAP1 MRPR3 (1/2P-P)	MRNB1A MRNB2 MRNB3 (1/2P-P)	MREB1A MREB2 MREB3 (1/2P-P)	MREB4A MRNB7 MRNB9A (1/2P-P)
41	0.101	10	5.1	167	-24	1381	0.7	250	561	402
11	40.3	0.080406	-68	-11	714	-78	333	153	536	125
				-8	397	1		104	476	72
41	0.091	10	5.1	163	-17	1338	0.6	182	537	422
12	36.4	0.08092	-83	-11	708	-68	253	117	451	107
				-8	395	3		108	484	82
41	0.081	10	5.1	165	23	1324	0.7	416	666	580
13	32.3	0.080306	-95	-8	738	-58	326	254	722	167
				0	389	7		151	713	112
41	0.041	10	5	199	62	10099	0.7	199	676	762
14	16.2	0.080581	-203	42	682	52	296	159	721	261
				58	214	51		125	804	121
41	0.029	10	4.9	197	48	10079	0.4	118	628	506
15	11.6	0.080226	-237	43	668	89	246	71	620	160
				60	191	74		54	628	77
41	0.019	10	4.8	199	71	10172	0.5	145	557	327
16	7.5	0.081095	-240	42	711	58	194	81	471	130
				58	244	83		74	417	77
41	0	10	4.9	211	75	10103	0.9	182	466	361
17	0	0.081806	-240	55	702	49	177	137	440	150
				67	234	92		102	426	76

RUN POINT	V/OR VKTS	ALFS,U CTH/S	MRFLAP1 MRPR3 (MEAN)	MRNB1A MRNB2 MRNB3 (MEAN)	MREB1A MREB2 MREB3 (MEAN)	MREB4A MRNB7 MRNB9A (MEAN)	MRFLAP1 MRPR3 (1/2P-P)	MRNB1A MRNB2 MRNB3 (1/2P-P)	MREB1A MREB2 MREB3 (1/2P-P)	MREB4A MRNB7 MRNB9A (1/2P-P)
41	0.01	10	4.8	210	84	10106	1.1	211	451	352
18	4.2	0.078567	-242	57 69	706 231	56 98	145	159 97	463 396	120 89
31	0.251	10.01	5.6	148	-158	1444	0.6	162	627	687
17	100.1	0.082746	-2	-27 2356	620 384	-124 -64	255	137 0	675 816	166 49
31	0.201	10.01	5.6	159	-130	1434	0.7	136	575	545
18	80	0.083472	-8	-15 2078	633 384	-117 -61	241	107 472	589 668	127 44
31	0.151	10.01	5.5	165	-90	1427	0.6	82	553	419
19	60.5	0.084241	-28	-9 2352	661 385	-99 -8	236	76 354	514 542	97 42
31	0.125	10.01	5.5	164	-65	1415	0.7	161	536	360
20	49.9	0.08413	-41	-9 2352	679 393	-91 -41	209	124 506	483 469	111 61
31	0.1	10.01	5.4	164	-21	1427	0.7	273	592	452
21	40.1	0.083976	-64	-10 2035	726 429	-75 -53	243	168 936	589 544	130 71
31	0.08	10.01	5.3	163	33	1375	0.6	449	706	636
22	32	0.084211	-89	-7 1758	759 431	-56 -47	324	283 1117	783 794	186 125

RUN POINT	V/OR VKTS	ALFS,U CTH/S	MRFLAP1 MRPR3 (MEAN)	MRNB1A MRNB2 MRNB3 (MEAN)	MREB1A MREB2 MREB3 (MEAN)	MREB4A MRNB7 MRNB9A (MEAN)	MRFLAP1 MRPR3 (1/2P-P)	MRNB1A MRNB2 MRNB3 (1/2P-P)	MREB1A MREB2 MREB3 (1/2P-P)	MREB4A MRNB7 MRNB9A (1/2P-P)
37	0.252	-10	5.7	245	144	1230	0.9	162	714	847
19	100.4	0.09972	-148	81	763	-46	353	108	763	196
				84	309	17		111	955	67
37	0.2	-10	5.8	243	110	1247	0.8	142	660	729
20	80.1	0.100693	-126	77	741	-38	340	92	666	166
				79	287	17		90	817	70
37	0.151	-10	5.9	242	102	1235	0.7	132	624	615
21	60.2	0.100604	-79	73	728	-20	347	92	605	167
				75	283	25		92	711	80
37	0.125	-10	5.9	244	106	1224	0.8	133	636	587
22	49.9	0.100762	-76	72	728	-10	353	102	591	171
				74	283	34		96	674	90
37	0.101	-10	5.9	243	107	1205	0.8	130	616	540
23	40.3	0.100291	-89	72	725	6	346	86	572	165
				74	274	49		87	639	98
37	0.091	-10	5.9	241	103	1190	0.7	131	627	557
24	36.4	0.100286	-84	71	719	18	392	70	564	155
				75	264	57		73	606	103
37	0.081	-10	5.8	240	94	1184	0.6	123	600	518
25	32.4	0.099795	-99	70	717	35	331	60	527	143
				75	252	65		61	572	105

RUN POINT	V/OR VKTS	ALFS,U CTH/S	MRFLAP1 MRPR3 (MEAN)	MRNB1A MRNB2 MRNB3 (MEAN)	MREB1A MREB2 MREB3 (MEAN)	MREB4A MRNB7 MRNB9A (MEAN)	MRFLAP1 MRPR3 (1/2P-P)	MRNB1A MRNB2 MRNB3 (1/2P-P)	MREB1A MREB2 MREB3 (1/2P-P)	MREB4A MRNB7 MRNB9A (1/2P-P)
37	0.06	-10	5.8	238	80	1131	0.5	136	609	483
26	24	0.100432	-121	71 79	695 219	67 78	309	68 50	548 594	149 90
37	0.05	-10	5.8	239	71	1106	0.4	131	622	495
27	20.1	0.100496	-125	73 82	683 199	77 83	293	64 47	591 629	139 84
37	0.041	-10	5.8	238	68	1101	0.4	130	607	454
28	16.3	0.100026	-137	74 84	682 191	83 91	274	62 45	556 582	124 75
37	0.03	-10	5.8	242	101	1131	0.3	112	562	402
29	11.8	0.100486	-133	75 84	710 226	71 98	232	49 43	504 506	107 60
37	0.02	-10	5.8	245	113	1156	0.6	154	541	397
30	7.9	0.10059	-138	77 88	727 248	62 92	208	100 70	484 500	121 66
37	0.013	-10	5.7	258	159	1178	1.1	154	440	492
31	5.2	0.100229	-152	87 95	760 271	58 94	147	113 85	448 527	138 95
33	0.251	-2	6.1	219	44	1323	0.6	188	683	842
5	100.1	0.100158	-148	46 51	717 328	-81 4	329	127 128	735 897	212 119

RUN POINT	V/OR VKTS	ALFS,U CTH/S	MRFLAP1 MRPR3 (MEAN)	MRNB1A MRNB2 MRNB3 (MEAN)	MREB1A MREB2 MREB3 (MEAN)	MREB4A MRNB7 MRNB9A (MEAN)	MRFLAP1 MRPR3 (1/2P-P)	MRNB1A MRNB2 MRNB3 (1/2P-P)	MREB1A MREB2 MREB3 (1/2P-P)	MREB4A MRNB7 MRNB9A (1/2P-P)
33	0.201	-2	6.1	222	53	1326	0.5	218	677	797
6	80.2	0.100369	-137	48	718	-72	348	142	731	206
				88	328	5		108	838	128
33	0.15	-2	6.1	225	67	1317	0.6	148	705	750
7	60	0.100376	-141	49	728	-54	356	107	734	197
				61	358	15		95	806	107
33	0.126	-2	6.1	228	66	1304	0.7	243	738	806
8	50.2	0.100913	-154	51	725	-43	425	176	755	213
				59	329	24		131	849	116
33	0.107	-2	6	229	69	1282	0.9	303	781	902
9	42.5	0.099783	-162	54	720	-30	361	226	819	234
				63	317	33		162	931	125
33	0.06	-2	5.9	238	93	1164	0.7	196	713	859
10	24	0.099461	-227	65	714	49	352	158	746	225
				82	228	100		120	874	133
33	0.05	-2	5.9	239	80	1110	0.5	159	635	663
11	20	0.100022	-249	69	690	76	345	117	595	195
				87	192	156		98	684	105
33	0.04	-2	5.9	238	76	1076	0.4	128	650	575
12	16	0.100006	-267	72	675	101	289	70	613	165
				91	172	165		55	688	85

RUN POINT	V/OR VKTS	ALFS,U CTH/S	MRFLAP1 MRPR3 (MEAN)	MRNB1A MRNB2 MRNB3 (MEAN)	MREB1A MREB2 MREB3 (MEAN)	MREB4A MRNB7 MRNB9A (MEAN)	MRFLAP1 MRPR3 (1/2P-P)	MRNB1A MRNB2 MRNB3 (1/2P-P)	MREB1A MREB2 MREB3 (1/2P-P)	MREB4A MRNB7 MRNB9A (1/2P-P)
33	0.031	-2	5.8	238	94	1113	0.4	129	577	424
13	12.2	0.100156	-271	72	700	88	265	71	506	125
				91	206	172		47	535	68
33	0.02	-2	5.8	244	130	1176	0.4	168	578	452
14	8.1	0.100851	-270	75	744	65	229	106	563	132
				92	249	174		66	591	72
33	0	-2	5.5	248	137	1155	1.3	232	465	721
15	0	0.098874	-272	81	740	76	166	171	576	197
				294	185	178		113	709	106
35	0.251	-2	6.2	216	52	1316	0.7	187	676	838
20	99.6	0.100138	-139	43	713	-83	345	117	723	211
				46	331	4		130	890	120
35	0.224	-2	6.2	219	58	1307	0.6	162	638	691
21	89	0.101098	-136	45	714	-81	355	119	668	193
				47	357	6		111	826	113
35	0.198	-2	6.2	219	63	1316	0.5	222	681	803
22	78.9	0.1001	-131	46	716	-73	355	140	756	210
				42	339	8		108	840	130
35	0.174	-2	6.2	223	71	1307	0.5	155	678	746
23	69.1	0.100757	-128	47	719	-64	362	106	710	192
				44	345	12		93	857	98

RUN POINT	V/OR VKTS	ALFS,U CTH/S	MRFLAP1 MRPR3 (MEAN)	MRNB1A MRNB2 MRNB3 (MEAN)	MREB1A MREB2 MREB3 (MEAN)	MREB4A MRNB7 MRNB9A (MEAN)	MRFLAP1 MRPR3 (1/2P-P)	MRNB1A MRNB2 MRNB3 (1/2P-P)	MREB1A MREB2 MREB3 (1/2P-P)	MREB4A MRNB7 MRNB9A (1/2P-P)
35	0.151	-2	6.2	224	76	1304	0.6	147	690	727
24	60.2	0.100339	-131	47 44	722 355	-57 16	356	108 93	714 789	198 106
35	0.125	-2	6.2	227	73	1291	0.8	258	725	802
25	49.7	0.100666	-145	49 48	720 342	-44 24	352	187 137	777 851	216 120
35	0.113	-2	6.1	224	73	1280	0.8	303	768	873
26	45.2	0.098773	-146	48 49	718 328	-37 28	349	215 154	816 928	227 126
35	0.06	-2	6	237	104	1130	0.7	196	722	809
27	23.9	0.10062	-224	67 72	700 230	53 75	354	158 121	725 851	217 119
35	0.05	-2	6	238	97	1097	0.6	160	650	661
28	20	0.100328	-243	69 77	692 210	80 84	336	111 95	623 702	195 104
35	0.042	-2	6	238	95	1070	0.5	139	636	563
29	16.7	0.100714	-260	72 81	682 185	101 92	311	70 57	608 665	169 90
35	0.031	-2	5.9	240	118	1130	0.4	125	549	401
30	12.2	0.100243	-263	71 80	722 231	83 98	265	73 51	465 502	123 69

RUN POINT	V/OR VKTS	ALFS,U CTH/S	MRFLAP1 MRPR3 (MEAN)	MRNB1A MRNB2 MRNB3 (MEAN)	MREB1A MREB2 MREB3 (MEAN)	MREB4A MRNB7 MRNB9A (MEAN)	MRFLAP1 MRPR3 (1/2P-P)	MRNB1A MRNB2 MRNB3 (1/2P-P)	MREB1A MREB2 MREB3 (1/2P-P)	MREB4A MRNB7 MRNB9A (1/2P-P)
39	0.249	5	6.4	193	-74	1367	0.5	153	630	779
21	99.2	0.099721	-80	14	639	-110	273	138	718	188
				6	335	-2		146	869	71
39	0.223	5	6.4	200	-51	1382	0.5	123	638	755
22	89	0.10008	-77	19	659	-112	274	109	669	166
				10	349	-3		119	832	82
39	0.198	5	6.3	202	-53	1374	0.5	148	636	674
23	78.7	0.100077	-75	22	655	-105	281	97	636	161
				11	347	-3		103	758	79
39	0.173	5	6.3	207	-22	1381	0.5	160	630	654
24	69	0.100694	-81	25	674	-98	371	105	570	173
				15	362	-3		93	662	86
39	0.151	5	6.3	208	-8	1392	0.5	160	616	613
25	60.1	0.100203	-84	25	691	-89	341	106	599	171
				15	376	1		85	676	79
39	0.124	5	6.2	205	18	1386	0.5	276	674	728
26	49.7	0.099859	-101	22	720	-71	279	132	678	188
				15	394	7		101	748	149
39	0.101	5	6.1	207	58	1339	0.7	420	725	798
27	40.2	0.09994	-127	27	740	-52	351	273	825	226
				26	386	14		188	957	136

RUN POINT	V/OR VKTS	ALFS,U CTH/S	MRFLAP1 MRPR3 (MEAN)	MRNB1A MRNB2 MRNB3 (MEAN)	MREB1A MREB2 MREB3 (MEAN)	MREB4A MRNB7 MRNB9A (MEAN)	MRFLAP1 MRPR3 (1/2P-P)	MRNB1A MRNB2 MRNB3 (1/2P-P)	MREB1A MREB2 MREB3 (1/2P-P)	MREB4A MRNB7 MRNB9A (1/2P-P)
39	0.051	5	6.2	251	98	1106	0.8	301	794	1094
28	20.3	0.104631	-238	76 80	690 211	63 70	367	234 163	823 1050	267 128
39	0.04	5	5.9	241	86	1071	0.5	182	637	619
29	16	0.100854	-261	73 80	679 171	111 84	316	101 85	594 692	192 98
39	0.03	5	5.9	241	92	1103	0.3	144	662	562
30	11.9	0.10021	-268	72 77	696 195	105 90	274	80 49	679 720	173 78
39	0.02	5	5.8	245	142	1182	0.5	149	584	457
31	8	0.100145	-261	73 76	754 271	72 96	244	110 80	541 557	157 92
39	0.01	5	5.9	264	141	1141	1.6	196	553	669
32	3.8	0.104272	-281	91 92	733 231	86 113	221	149 114	669 772	173 89
41	0.251	10	6.6	186	-177	10244	0.6	209	686	854
19	99.8	0.100608	-59	-5 -17	555 294	-127 -8	317	157 166	834 1032	180 56
41	0.229	10	6.6	191	-159	10243	0.6	160	659	823
20	91.3	0.100617	-55	1 -11	569 306	-127 -8	316	139 144	755 917	163 61

RUN POINT	V/OR VKTS	ALFS,U CTH/S	MRFLAP1 MRPR3 (MEAN)	MRNB1A MRNB2 MRNB3 (MEAN)	MREB1A MREB2 MREB3 (MEAN)	MREB4A MRNB7 MRNB9A (MEAN)	MRFLAP1 MRPR3 (1/2P-P)	MRNB1A MRNB2 MRNB3 (1/2P-P)	MREB1A MREB2 MREB3 (1/2P-P)	MREB4A MRNB7 MRNB9A (1/2P-P)
41	0.2	10	6.5	197	-133	10296	0.6	142	611	684
21	80	0.099893	-55	7	593	-121	279	110	646	143
				-7	324	-5		120	759	50
41	0.178	10	6.5	199	-109	10294	0.6	114	602	614
22	70.9	0.100064	-56	10	608	-113	278	93	589	126
				-3	336	-5		99	665	51
41	0.151	10	6.4	201	-81	10216	0.7	98	566	547
23	60.1	0.09996	-66	12	630	-104	256	82	529	117
				1	348	-3		92	599	50
41	0.125	10	6.3	200	-48	10245	0.7	143	555	478
24	49.7	0.100047	-75	11	662	-99	243	120	524	125
				1	372	1		106	530	67
41	0.101	10	6.3	199	21	10536	0.6	257	620	685
25	40.1	0.100426	-103	10	726	-77	282	189	590	129
				0	432	6		121	733	76
41	0.091	10	6.2	202	47	11420	0.8	523	836	942
26	36.2	0.100792	-103	13	742	-68	417	311	1048	211
				8	414	-47		157	1003	180
41	0.04	10	6	250	88	5051	0.6	233	692	862
27	16.1	0.100627	-243	77	656	93	441	162	736	255
				83	146	30		125	846	113

RUN POINT	V/OR VKTS	ALFS,U CTH/S	MRFLAP1 MRPR3 (MEAN)	MRNB1A MRNB2 MRNB3 (MEAN)	MREB1A MREB2 MREB3 (MEAN)	MREB4A MRNB7 MRNB9A (MEAN)	MRFLAP1 MRPR3 (1/2P-P)	MRNB1A MRNB2 MRNB3 (1/2P-P)	MREB1A MREB2 MREB3 (1/2P-P)	MREB4A MRNB7 MRNB9A (1/2P-P)
41	0.029	10	5.9	247	81	5067	0.4	142	659	732
28	11.6	0.100285	-260	77	659	106	446	78	620	166
				81	154	46		59	683	85
41	0.018	10	5.9	257	127	5167	0.8	220	600	586
29	7.1	0.101429	-259	82	717	61	435	175	533	200
				81	240	54		119	533	105
41	0	10	5.6	256	165	5199	1	194	539	828
30	0	0.100003	-253	86	746	61	279	154	652	215
				87	249	52		139	948	85

REPORT DOCUMENTATION PAGE

Form Approved
OMB No. 0704-0188

Public reporting burden for this collection of information is estimated to average 1 hour per response, including the time for reviewing instructions, searching existing data sources, gathering and maintaining the data needed, and completing and reviewing the collection of information. Send comments regarding this burden estimate or any other aspect of this collection of information, including suggestions for reducing this burden, to Washington Headquarters Services, Directorate for Information Operations and Reports, 1215 Jefferson Davis Highway, Suite 1204, Arlington, VA 22202-4302, and to the Office of Management and Budget, Paperwork Reduction Project (0704-0188), Washington, DC 20503.

1. AGENCY USE ONLY (Leave blank)	2. REPORT DATE April 1996	3. REPORT TYPE AND DATES COVERED Technical Memorandum	
4. TITLE AND SUBTITLE Full-Scale S-76 Rotor Performance and Loads at Low Speeds in the NASA Ames 80- by 120-Foot Wind Tunnel Volume 1*		5. FUNDING NUMBERS 505-59-36	
6. AUTHOR(S) Patrick M. Shinoda		8. PERFORMING ORGANIZATION REPORT NUMBER A-960974	
7. PERFORMING ORGANIZATION NAME(S) AND ADDRESS(ES) Ames Research Center Moffett Field, CA 94035-1000		10. SPONSORING/MONITORING AGENCY REPORT NUMBER NASA TM-110379	
9. SPONSORING/MONITORING AGENCY NAME(S) AND ADDRESS(ES) National Aeronautics and Space Administration Washington, DC 20546-0001		11. SUPPLEMENTARY NOTES Point of Contact: Patrick M. Shinoda, Ames Research Center, MS T-12B, Moffett Field, CA 94035-1000; (415) 604-6732 *Volume 1 contains the main text and Appendices A-C. Volume 2 contains Appendix D.	
12a. DISTRIBUTION/AVAILABILITY STATEMENT Unclassified — Unlimited Subject Category 02		12b. DISTRIBUTION CODE	
13. ABSTRACT (Maximum 200 words) A full-scale helicopter rotor test was conducted in the NASA Ames 80- by 120-Foot Wind Tunnel with a four-bladed S-76 rotor system. Rotor performance and loads data were obtained over a wide range of rotor shaft angles-of-attack and thrust conditions at tunnel speeds ranging from 0 to 100 kt. The primary objectives of this test were (1) to acquire forward flight rotor performance and loads data for comparison with analytical results; (2) to acquire S-76 forward flight rotor performance data in the 80- by 120-Foot Wind Tunnel to compare with existing full-scale 40- by 80-Foot Wind Tunnel test data that were acquired in 1977; (3) to evaluate the acoustic capability of the 80- by 120-Foot Wind Tunnel for acquiring blade vortex interaction (BVI) noise in the low speed range and compare BVI noise with in-flight test data; and (4) to evaluate the capability of the 80- by 120-Foot Wind Tunnel test section as a hover facility. The secondary objectives were (1) to evaluate rotor inflow and wake effects (variations in tunnel speed, shaft angle, and thrust condition) on wind tunnel test section wall and floor pressures; (2) to establish the criteria for the definition of flow breakdown (condition where wall corrections are no longer valid) for this size rotor and wind tunnel cross-sectional area; and (3) to evaluate the wide-field shadowgraph technique for visualizing full-scale rotor wakes. This data base of rotor performance and loads can be used for analytical and experimental comparison studies for full-scale, four-bladed, fully articulated rotor systems. Rotor performance and structural loads data are presented in this report.			
14. SUBJECT TERMS Helicopter, Rotor performance, Rotor dynamics		15. NUMBER OF PAGES 241	16. PRICE CODE A99
17. SECURITY CLASSIFICATION OF REPORT Unclassified	18. SECURITY CLASSIFICATION OF THIS PAGE Unclassified	19. SECURITY CLASSIFICATION OF ABSTRACT	20. LIMITATION OF ABSTRACT



