

11-13
657007

NASA Technical Memorandum 107207

Effects of Thermomechanical Processing on the Microstructure and Mechanical Properties of Nb-1Zr-C Alloys

Robert H. Titran
Lewis Research Center
Cleveland, Ohio

and

Mehmet Uz
Lafayette College
Easton, Pennsylvania

Prepared for the
Fourth Specialist Conference on "Nuclear Power Engineering in
Space Materials Fuel"
cosponsored by The Ministry of the Russian Federation on Atomic Energy;
Russian Scientific Center (PCS) "Kurchatov Institute;"
and Scientific-Industrial Association LUTCH
Podolsk, Russia, September 21–24, 1993



National Aeronautics and
Space Administration

Trade names or manufacturers' names are used in this report for identification only. This usage does not constitute an official endorsement, either expressed or implied, by the National Aeronautics and Space Administration.

EFFECTS OF THERMOMECHANICAL PROCESSING ON THE MICROSTRUCTURE AND MECHANICAL PROPERTIES OF Nb-1Zr-C ALLOYS

Robert H. Titran
National Aeronautics and Space Administration
Lewis Research Center
Cleveland, Ohio 44135

and

Mehmet Uz
Chemical Engineering Department
Lafayette College
Easton, Pennsylvania 18042

SUMMARY

A systematic study to evaluate the effects of thermomechanical processing on the microstructure and mechanical properties of Nb-1Zr alloy sheet containing 0.06 and 0.1 wt %C (PWC-11) was conducted and compared to the results of Nb-1Zr. Coarse orthorhombic Nb₂C precipitates were present in all the cast, extruded and cold rolled Nb-Zr samples containing C. After high temperature (>0.5T_m) exposure (with or without applied stress), the Nb₂C transforms to very fine and extremely stable FCC (Zr,Nb)C dispersoid, resulting in a highly creep resistant material. Only ZrO₂ precipitates were found in Nb-1Zr. The creep strength of the 0.06C and the 0.1C carbide strengthened alloys were much superior to Nb-1Zr. At 1350K the strength of the 0.06C alloy was about three times that of Nb-1Zr, while the 0.1C alloy had about five times the creep stress capability of Nb-1Zr. The tensile strength, long term creep strength, and stability of the microstructure of the PWC-11 sheet appear to be independent of the number of 1900K extrusions performed prior to cold rolling. The microhardness of these single, double and triple extruded PWC-11 sheets also were comparable. The tensile strength of PWC-11 and Nb-1Zr at room temperature and 1350K were comparable.

INTRODUCTION AND BACKGROUND

Power requirements for current and future civil space missions, such as exploration of the Moon and Mars, are expected to range from hundreds of watts to several megawatts. Advanced nuclear power systems currently appear to be the only feasible choice to provide such levels of power for the anticipated times. A critical concern is the selection of appropriate materials to meet the design requirements of the advanced nuclear power systems. These requirements currently include a service life of 7 to 10 years or more under stresses of 5 to 25 MPa at 1350 to 1450K in an environment of liquid alkali metals such as lithium and total allowable creep strain of 2 percent maximum (refs. 1 and 2).

Niobium (Nb)-zirconium (Zr) alloys both with or without carbon (C) are leading candidate materials for such space power systems based primarily on the resistance of Nb and its alloys to liquid alkali metal corrosion and their lower densities as compared to other refractory metals and alloys. Initially, the Nb-1 wt % Zr alloy was suggested for use in space power conversion systems with a service temperature of about 1000K and a maximum stress of around 10 MPa (refs. 3 and 4). Advanced space power systems, involving higher stresses at higher temperatures for longer times, require a stronger and more thermally stable material.

Substantial work has been reported on Nb-1Zr-C alloys, especially on a Nb-1Zr alloy containing 0.06C (referred to as LC in this report) including its microstructure, long-term creep strength, and weldability (refs. 5 to 9). However, the relationship between processing, microstructure and properties has not been well established for these alloys.

The present study on PWC-11 (Nb-1Zr-0.1C alloy) is part of the NASA Lewis Research Center's ongoing evaluation of Nb-Zr-C alloys. The purpose of this work was to determine if PWC-11 could meet the requirements of the SP-100 space power system and could replace Nb-1Zr in critical applications. In earlier studies (refs. 5 and 6), a double-annealed (DA), 1h at 1755K + 2h at 1475K, Nb-1Zr-0.06C alloy was reported to have about three times the creep life of a similarly heat treated Nb-1Zr alloy when tested at 1350K and 10 MPA. Under these creep test conditions, the alloy containing 0.06 C had no measurable creep strain after 34 500 h, while the Nb-1Zr alloy achieved 2 percent strain in 18 000 h. The Nb-1Zr alloy containing C owes its superior creep resistance to the presence of extremely stable cubic carbides of Zr and Nb (refs. 7 and 8).

This paper deals with the characterization of the strength and stability of PWC-11 sheet as effected by the thermo-mechanical processing employed in its fabrication and the subsequent heat treatment prior to its use in service. In particular, the paper discusses the effects of multiple hot-extrusions prior to cold rolling as well as the effects of various high-temperature anneals and composition on the microstructure, microhardness, tensile and creep properties of PWC-11. Results on Nb-1Zr and Nb-1Zr-0.06C alloys are included for comparison purposes and detailed information about them can be found in earlier work (refs. 6 to 8, and 10 to 12).

EXPERIMENTAL PROCEDURE

Materials and Apparatuses

The nominal compositions of the materials evaluated in this study are given in table I. All the alloys were in 1-mm thick sheet form. The PWC-11 samples were all fabricated from a vacuum arc-melted ingot by a combination of hot extrusion and cold rolling. The extrusion operations were performed at 1900K with an extrusion ratio of 4:1. The primary difference between 064A, 064B and 064C was that they were, respectively, single-, double- and triple-extruded prior to cold rolling to 1-mm sheet.

TABLE I—CHEMICAL COMPOSITIONS OF DOUBLE-ANNEALED
(DA: 1 H at 1755 K + 2 H at 1475 K)
Nb-1Zr AND Nb-1Zr-C ALLOYS.

Sample	Material identification	Chemical composition				
		O ^a	N ^b	C ^b	Zr ^c	Nb
Nb-1Zr	Nb-1Zr	0.0170	0.0041	0.0016	1.1	Balance
LC-DA	Nb-1Zr-0.06C	0.0080	0.0053	0.0630	0.90	↓
064A-DA	PWC-11	0.0028	0.0019	0.0921	0.95	
064B-DA	PWC-11	0.0033	0.0022	0.0914	0.95	
064C-DA	PWC-11	0.0022	0.0009	0.0944	0.95	

^aInert-gas fusion method.

^bCombustion extraction method.

^cInductively-coupled plasma method.

An internally-loaded, constant-load, ultrahigh vacuum chamber was used for the creep tests. It is equipped with split-sleeve resistance heaters (ref. 11) and a viewing port to facilitate optical creep measurements. Ultrahigh vacuum chambers were also used for all the heat treatments. The pressure in these high-temperature chambers during testing was of the order of 10^{-6} Pa. A screw-driven tensile testing machine was used for both the room and high temperature tensile tests. Temperatures were measured using an R-type (Pt/Pt-13 percent Rh) thermocouple and was maintained within $\pm 5^\circ$ of the intended test temperature. A microhardness tester equipped with a diamond pyramid indenter and a digital processor/printer was used for the hardness measurements.

All the testing and evaluation in this study were conducted in the longitudinal (parallel to rolling) direction of the sheet. First, all specimens were chemically cleaned in a solution of 3H₂O:1HNO₃:1HF by volume. Next, all specimens were wrapped in chemically-cleaned tantalum foil prior to heat treating and again before high temperature testing. The creep and tensile test specimens were similar in geometry. A sketch of a typical test specimen is shown figure 1.

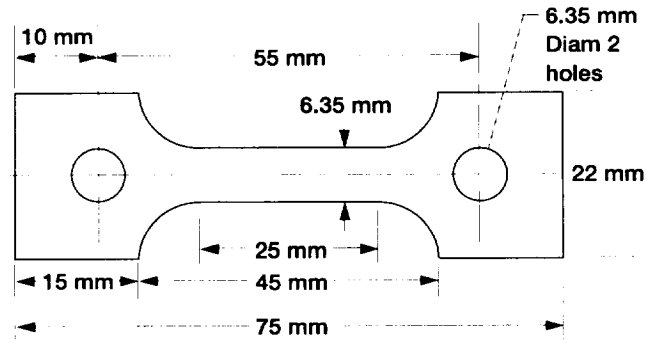

Figure 1.—A schematic of the specimens used in tensile and creep tests.

Fiducial marks were placed 25 mm apart in the gage section of each specimen for measurement of elongation.

All sheet samples were examined in both the as-polished and the etched condition by light microscopy and scanning electron microscopy (SEM) for precipitate morphology and grain size. Phase extraction was performed on each specimen listed in table I. The residue obtained from each was analyzed by (1) x-ray spectroscopy for precipitate identification and (2) an inductively-coupled plasma (ICP) method for Nb and Zr contents. The double-annealed PWC-11 samples were also examined by transmission electron microscopy (TEM) to verify the results from X-ray analysis of the residue. Energy-dispersive X-ray spectroscopy (XEDS) using SEM was also performed on various residue samples to verify the trends observed from the ICP results.

RESULTS AND DISCUSSION

Creep properties

Uniaxial creep tests were conducted on 1-mm thick sheets of Nb-1Zr, Nb-1Zr-0.06C, and PWC-11 at 1350 and 1450K as shown in table II. The pertinent results of table II are the final creep strain, the linear strain rate, and a power law extrapolation of the time to achieve 1 or 2 percent total creep strain. One sample from each of the 064A-DA, 064B-DA and 064C-DA (see table II) was creep tested at 1350K and 34.5 MPa. The test results indicate that PWC-11 has a creep rate about one-third that of the LC alloy and more than an order of magnitude less than Nb-1Zr. At 1350K a trend may exist that creep resistance decreases as the number of extrusions increased. However the results of an ongoing test at 1450K and 24 MPA on PWC-11 suggests the opposite with sample 064C being the most creep resistant. It is evident from the creep data presented here that the carbide strengthened Nb-1Zr alloys have much better creep resistance than the solid solution-strengthened Nb-1Zr alloy at 1350K, which should also hold at 1450K as well. This is to be expected because of the presence of extremely stable cubic carbides of (Zr,Nb)C which were shown to form during testing mainly as a result of transformation from Nb₂C (refs. 8 and 12). It is also obvious from the results that increasing the carbon content from 0.06 to 0.1 percent gives rise to a marked increase in the creep resistance of the alloy.

TABLE II.—RESULTS OF CREEP TESTS AT 1350 AND 1450K FOR Nb-1Zr AND Nb-1Zr-C ALLOYS

Sample	Test conditions			Test results		Time to strain ^c	
	Time, h	T, K	σ , MPa	Total, ^e percent	Linear ^b $\dot{\epsilon}$ (h^{-1})	1 percent, 10^3 h	2 percent, 10^3 h
Nb-1Zr-DA	31,780	1350	10	4.06	$(14 \pm 0.07) \times 10^{-5}$	7.1-7.2 (11) ^d	14.2-14.4 (18) ^d
LC-DA	34,500	1350	10	e	e	e	e
LC-DA	32,500	1350	10	0.1	$(3.2 \pm 0.56) \times 10^{-6}$	266-378	532-756
Nb-1Zr-DA	218	1350	34.5	5.18	$(233 \pm 2.3) \times 10^{-5}$	0.04-0.05 (0.075) ^d	0.08-0.10 (0.125) ^d
LC-DA	4,288	1350	34.5	1.65	$(39.7 \pm 5) \times 10^{-5}$	2.30-2.90 (3.2) ^d	4.6-5.8
064A-DA	18,780	1350	34.5	0.29	$(11.6 \pm 1.7) \times 10^{-6}$	75.2-101	150.4-202
064B-DA	15,460	1350	34.5	0.21	$(14 \pm 0.8) \times 10^{-6}$	67.5-75.5	135-151
064C-DA	9,950	1350	34.5	0.27	$(17 \pm 1.1) \times 10^{-6}$	55-63	110-126
064A-DA*	11,800	1450	24	0.82	$(64 \pm 2) \times 10^{-6}$	15.2-16.2	30.4-32.4
064B-DA*	10,000	1450	24	0.29	$(16.1 \pm 2.5) \times 10^{-6}$	53.5-73.5	107-147
064C-DA*	11,100	1450	24	0.16	$(9.7 \pm 1.4) \times 10^{-6}$	90-120	180-240

^aCreep test in progress

^bSteady-state creep rate as calculated from the slope of the strain versus time plot.

^cEstimated using the linear strain rate in column 6.

^dExperimental times as observed during the creep test.

^eThis sample had no measurable strain at the conclusion of the creep test.

Tensile Properties

Duplicate tensile tests on 064A-DA, 064B-DA and 064C-DA specimens were conducted at 300 and 1350K. The cross-head speed during these tests was about 21×10^{-6} m/s which corresponds to a strain rate of about $8 \times 10^{-4} s^{-1}$ assuming that the deformation was restricted to the 25-mm gage section of the sample. The tensile properties, ultimate tensile strength (UTS), 0.2 percent offset yield strength (YS), ductility (ϵ) and uniform elongation (ϵ_u) were determined from a load-time plot and are reported in table III. The results indicate that multiple extrusions did not have a significant effect on the tensile strength of PWC-11. It is noteworthy that the tensile strength of Nb-1Zr is about equal to PWC-11.

Microhardness

Vickers hardness measurements were made on all of the PWC-11 samples listed in table I and are reported in table IV. Microhardness measurements were made on PWC-11 sheet in the as-rolled and double-annealed (DA) conditions as well as on their creep stressed section (M) and creep stress free end (E) section. The results show that in a given condition, the microhardness of the specimens from the single-, double- and triple-extruded sheet fall within about one standard deviation of one another. This indicates that the number of extrusions given prior to cold rolling did not have a residual effect on the microhardness of these samples regardless of the condition.

TABLE III.—RESULTS OF TENSILE TESTS ON SAMPLES FROM NB-1ZR AND NB-1ZR-0.1C SHEETS AT 300 AND 1350K.

Sample	Test conditions		Test results			
	Temperature, K	$\dot{\epsilon} \times 10^4$, 1/sec ^b	UTS, MPa	0.2 percent YS, MPa	ϵ , percent ^b	ϵ_u percent ^b
Nb-1Zr ^a	300	4	224	127	41	26
	1350	4	126	76	33	18
064A-DA	300	8.33	263.9	108.1	35.8	24.8
	1350	8.33	126.3	88.1	42.1	14.9
064B-DA	300	8.33	257.3	105.4	35.2	24.4
	1350	8.33	115.9	84.1	39.6	13.1
064C-DA	300	8.33	281.0	134.2	28.1	19.8
	1350	8.33	134.9	113.1	24.0	5.3

^aFrom Reference [10].

^bBased on the assumption that the elongation was restricted to the 25-mm gage region.

TABLE IV.—MICROHARDNESS OF PWC-11 (Nb-1Zr-0.1C) SHEET SAMPLES.

Sample	Vickers hardness number (VHN)	Standard deviation $\mp S_n$
064A	179.1	5.8
064A-DA	104.0	4.0
064A-DA(E)	90.3	4.6
064A-DA(M)	112.2	10.1
064B	163.0	10.0
064B-DA	95.5	9.1
064B-DA(E)	101.9	10.7
064B-DA(M)	128.3	3.8
064C	157.5	6.5
064C-DA	104.0	5.2
064C-DA(E)	100.4	5.4
064C-DA(M)	112.9	4.3

Double-annealing (DA) resulted in a decrease of about 40 percent in the microhardness of each sample. The stressed middle of each sample had a slightly higher microhardness than its stress-free ends. This is believed due to the strain induced in the reduced gage section of the crept sample even though the total creep strain in each was extremely small. It is very interesting to note from the results that prolonged exposure to 1350K for approximately 10 000 to 19 000 h had no measurable effect on the microhardness of the double-annealed samples. This is attributed to the predominant presence of the extremely stable and finely-distributed cubic carbides of (Zr,Nb)C in the crept samples.

Microstructure

The microstructure of the PWC-11 was studied at all stages of its processing, heat treatment and after testing (ref. 12).

As-Received-Samples.—The as-cast, as-extruded and as-rolled materials yielded microstructures which were typical of their respective processed condition. Coarse needle-like precipitates were distributed throughout the

matrix and somewhat continuously along the grain boundaries of the cast sample. Most of these precipitates were over 10 μm along their major axis. The 4:1 extrusion at 1900K caused the precipitates to break down, and align in the extrusion direction; however, needle-like precipitates, similar to those in the as-cast sample, were also present. The cold-rolled samples had microstructures with highly-deformed grains and precipitates aligned in the rolling direction. The precipitates were more discrete and circular, and varied in size from less than 1 μm to over 5 μm . It was evident that marked changes in precipitate morphology and distribution took place during the operations used in sheet fabrication.

Annealed Samples.—The microstructure of LC-DA appeared recrystallized. The grains were nominally equiaxed with an aspect ratio of less than 2 and an average grain size of about 25 μm . Noticeable differences among the microstructures of the double-annealed samples from the single-, double- and triple-extruded PWC-11 sheets were evident. Both 064A-DA and 064B-DA had relatively equiaxed grains with an aspect ratio of less than 3 indicating full recrystallization, but 064C-DA had mostly elongated grains with aspect ratios varying from 1 to nearly 10. The average grain size of these samples were approximately 30, 40 and 75 μm for 064A-DA, 064B-DA and 064C-DA, respectively. These observations indicate that the degree of recrystallization and average grain size increased with increased number of extrusions. This may be due to the marked difference in the percent cold work (%CW) in the as-rolled PWC-11 sheets. The %CW in 064C (66 percent) was much smaller than that in either of the 064A and 064B (96 and 88 percent, respectively). This could lead to lower nucleation sites and less driving force for recrystallization. Regardless of the apparent differences in grain size, the precipitates, varying in size (from 1 to about 5 μm), were finely distributed throughout the matrix and along the grain boundaries in all the samples. Precipitates appeared to be more abundant in the PWC-11 samples than in the LC samples.

Crept Samples.—Figures 2(a) to (d) shows the microstructures of the stressed gage sections of samples LC-DA, 064A-DA, 064B-DA and 064C-DA. The microstructure of the gage and stress-free end sections of each sample were similar (ref. 12). This was not unexpected, because the total strain in each of the crept samples was negligibly small (< 0.3 percent).



Figure 2.—Microstructure of the gage sections of the samples after creep testing at 1350 K and (a) 10 MPa for 34 500 h (LC-DA), (b) 34.5 MPa for 18 780 h (064A-DA), (c) 34.5 MPa for 15 460 h (064B-DA), (d) 34.5 MPa for 9950 h (064C-DA). All were as-polished and etched, DIC.

The grain size of these samples did not change significantly as a result of creep testing. Even sample LC-DA exposed at 1350K for over 34 000 h with or without the applied stress did not change, which indicates the excellent high-temperature stability of the Nb-1Zr-0.06C alloy.

SEM was used to verify the presence of precipitates. Results of back-scattered electron images showed that the precipitates were carbides of Nb and/or Zr. The carbides varied in size, and were rather coarse and somewhat continuous along the grain boundaries before creep testing, however, they were a 1 μm diameter or less and finely-distributed throughout the matrix after testing.

Phase-Extracted Residue

The results of the analyses of the phase-extracted residue from each sample are tabulated in table V. The precipitates in the as-cast ingots and the as cold rolled 1-mm sheet of the Nb-1Zr-C alloys were orthorhombic Nb₂C, and the residue analyzed nearly all Nb. In the double-annealed (DA) samples, some cubic phase, (Zr,Nb)C was detected together with Nb₂C, and this was accompanied by a very small increase in Zr/Nb ratio. The only phase detected in the crept samples was (Zr,Nb)C with a Zr/Nb ratio of greater than 1. The lattice parameters, a₀, of the cubic phase in table V, 0.450 to 0.468 nm fall between the a₀ values of NbC (≈0.447 nm) and ZrC (≈0.470 nm). It is likely that the cubic precipitates identified are solid solutions of NbC and ZrC. As the phase transformation from Nb₂C to (Zr,Nb)C increased, the Zr/Nb ratio in the residue of a sample also increased and was generally accompanied by an increase in the a₀ value of the cubic carbide.

TABLE V.—RESULTS OF THE ANALYSIS OF PHASE-EXTRACTED RESIDUE FROM Nb-1Zr-0.06C (LC) AND PWC-11 (Nb-1Zr-0.1C) 064 SAMPLES.

Sample	X-ray Analysis				Zr/Nb RATIO	
	Phases	Lattice parameters (nm)			Chemical analysis	SEMP XEDS
		a ₀	b ₀	c ₀		
LC	Nb ₂ C	1.092	0.480	0.311	1/99	
	(Zr,Nb)C	0.468				
LC-DA	Nb ₂ C	1.092	0.480	0.310	4/96	
	(Zr,Nb)C	0.458				
LC-DA10(E)	(Zr,Nb)C	0.465			72/27	
LC-DA10(M)	(Zr,Nb)C	0.464			63/37	
LC-DA/AGE	(Zr,Nb)C	0.460			38/62	
LC-DA/AGE(E)	(Zr,Nb)C	0.465			60/40	
LC-DA/AGE(M)	(Zr,Nb)C	0.465			56/44	
064-INGOT	Nb ₂ C	1.092	0.480	0.310	2/98	
064A	Nb ₂ C	1.092	0.497	0.311	3/97	
	(Zr,Nb)C	0.453				
064A-DA	Nb ₂ C	1.090	0.480	0.299	10/90	11/89
	(Zr,Nb)C	0.450				
064A-DA(E)	(Zr,Nb)C	0.454			58/42	
064A-DA(M)	(Zr,Nb)C	0.454			54/46	
064B	Nb ₂ C	1.090	0.499	0.311	14/96	
	(Zr,Nb)C					
064B-DA	Nb ₂ C				37/63	30/70
	(Zr,Nb)C	0.459				
064B-DA(E)	(Zr,Nb)C	0.456			63/37	
064B-DA(M)	(Zr,Nb)C	0.454			57/44	
064C	Nb ₂ C	1.090	0.497	0.311	25/75	
	(Zr,Nb)C					
064C-DA	(Zr,Nb)C	0.459			63/37	71/29
064C-DA(E)	(Zr,Nb)C	0.459			72/28	
064C-DA(M)	(Zr,Nb)C	0.458			85/15	

*Average of analysis of 4 areas ranging in size 250×250 mm to 5×5 mm.

CONCLUSIONS

Microhardness, tensile and long-term creep behavior of PWC-11 sheet with different processing histories were studied. The sheets studied were fabricated by cold rolling following single, double or triple extrusion operations at 1900K. The purpose was to determine the effects of thermomechanical processing on the properties and to assess the feasibility of the use of these materials in advanced power system applications. From the results obtained in this study on the Nb-1Zr-0.1C sheets and the previous results on Nb-1Zr and Nb-1Zr-0.06C sheets, the following conclusions could be drawn:

1. At 1350 to 1450K the carbide-strengthened alloys containing 0.06 or 0.1 percent C are much more creep resistant than the solid-solution strengthened Nb-1Zr due to the presence of the extremely stable fine carbides of Zr and Nb, (Zr,Nb)C.
2. The samples from the single-, double- and triple-extruded PWC-11 sheets (064A-DA, 064B-DA and 064C-DA, respectively) have more than adequate creep and tensile strength and ductility for the intended advanced power applications.
3. Multiple extrusions appear to have very little, if any, beneficial effect on the creep behavior of the PWC-11 sheet at 1350 K
4. The number of 1900K extrusions prior to cold rolling does not have a significant effect on the microhardness of PWC-11 sheet in the as-rolled, or double-annealed condition. Microhardness decreases (\approx 40 percent) significantly upon double annealing, but is not affected by subsequent exposure to 1350K for as long as 19 000 hr.

REFERENCES

1. R.H. Cooper, Jr.: in **Refractory Alloy Technology for Space Nuclear Power Applications**, R.H. Cooper, Jr. and E.E. Hoffman, eds., Technical Information Center, U. S. Department of Energy, Oak Ridge, TN, 1984, pp. 14–17.
2. R.H. Titran: **Advanced Materials and Processes**, 1992, vol. 142, No. 5, pp. 34–41.
3. J.R. Lane and G.M. Ault: **Met. Engrg. Q.**, 1965, vol. 5, pp. 23–29.
4. R.W. Buckman, Jr. in **Refractory Alloy Technology for Space Nuclear Power Applications**, R.H. Cooper, Jr. and E.E. Hoffman, eds., Technical Information Center, U. S. Department of Energy, Oak Ridge, TN, 1984, pp. 86–97.
5. R.H. Titran: **NASA Report, No. TM-100142**, NASA Lewis Research Center, Cleveland, OH, 1986.
6. R.H. Titran: **NASA Report, No. TM-102390**, NASA Lewis Research Center, Cleveland, OH, 1990.
7. R.H. Titran, T.J. Moore and T.L. Grobstein: **NASA Report, No. TM-89834**, NASA Lewis Research Center, Cleveland, OH, 1987.
8. M. Uz and Titran: **NASA Report, No. TM-103647**, NASA Lewis Research Center, Cleveland, OH, 1991.
9. E.J. DelGrosso, C.E. Carlson and J.J. Kaminsky: **J. Less-Common Metals**, 1967, vol 12, pp. 173–201.
10. J.A. Horak, M.M. Paxton and L.K. Egner: **ORNL Report, No. ORNL/TM-11430**, Office of Scientific and Technical Information, U. S. Department of Energy, Oak Ridge, TN, 1991.
11. R.W. Hall and R.H. Titran: in **Refractory Metals and Alloys III**, R.I. Jaffee, ed., Gordon and Breach Science Publishers, New York, 1966, pp. 885–900.
12. M.Uz and R.H. Titran: in **AIP Conference Proceedings 271**, M. S. El-Genk and M. D. Hoover, eds., DOE Conference 930103, American Institute of Physics, New York, 1993, pp. 69–83.

REPORT DOCUMENTATION PAGE

Form Approved
OMB No. 0704-0188

Public reporting burden for this collection of information is estimated to average 1 hour per response, including the time for reviewing instructions, searching existing data sources, gathering and maintaining the data needed, and completing and reviewing the collection of information. Send comments regarding this burden estimate or any other aspect of this collection of information, including suggestions for reducing this burden, to Washington Headquarters Services, Directorate for Information Operations and Reports, 1215 Jefferson Davis Highway, Suite 1204, Arlington, VA 22202-4302, and to the Office of Management and Budget, Paperwork Reduction Project (0704-0188), Washington, DC 20503.

1. AGENCY USE ONLY (Leave blank)		2. REPORT DATE May 1996	3. REPORT TYPE AND DATES COVERED Technical Memorandum	
4. TITLE AND SUBTITLE Effects of Thermomechanical Processing on the Microstructure and Mechanical Properties of Nb-1Zr-C Alloys			5. FUNDING NUMBERS WU-505-63-5A	
6. AUTHOR(S) Robert H. Titran and Mehmet Uz				
7. PERFORMING ORGANIZATION NAME(S) AND ADDRESS(ES) National Aeronautics and Space Administration Lewis Research Center Cleveland, Ohio 44135-3191			8. PERFORMING ORGANIZATION REPORT NUMBER E-10220	
9. SPONSORING/MONITORING AGENCY NAME(S) AND ADDRESS(ES) National Aeronautics and Space Administration Washington, D.C. 20546-0001			10. SPONSORING/MONITORING AGENCY REPORT NUMBER NASA TM-107207	
11. SUPPLEMENTARY NOTES Prepared for the Fourth Specialist Conference on "Nuclear Power Engineering in Space Materials Fuel" cosponsored by The Ministry of the Russian Federation on Atomic Energy; Russian Scientific Center (PCS) "Kurchatov Institute;" and Scientific-Industrial Association (LUTCH); Podolsk, Russia, September 21-24, 1993. Robert H. Titran, NASA Lewis Research Center and Mehmet Uz, Lafayette College, Chemical Engineering Department; Lafayette College, Easton, Pennsylvania 18042. Responsible person, Robert H. Titran, organization code 5120, (216) 433-3198.				
12a. DISTRIBUTION/AVAILABILITY STATEMENT Unclassified - Unlimited Subject Category 26 This publication is available from the NASA Center for AeroSpace Information, (301) 621-0390.			12b. DISTRIBUTION CODE	
13. ABSTRACT (Maximum 200 words) A systematic study to evaluate the effects of thermomechanical processing on the microstructure and mechanical properties of Nb-1Zr alloy sheet containing 0.06 and 0.1 wt.%C (PWC-11) was conducted and compared to the results of Nb-1Zr. Coarse orthorhombic Nb ₂ C precipitates were present in all the cast, extruded and cold rolled Nb-Zr samples containing C. After high temperature (>0.5T _m) exposure (with or without applied stress), the Nb ₂ C transforms to very fine and extremely stable FCC (Zr, Nb)C dispersoid, resulting in a highly creep resistant material. Only ZrO ₂ precipitates were found in Nb-1Zr. The creep strength of the 0.06C and the 0.1C carbide strengthened alloys were much superior to Nb-1Zr. At 1350K the strength of the 0.06C alloy was about three times that of Nb-1Zr, while the 0.1C alloy had about five times the creep stress capability of Nb-1Zr. The tensile strength, long term creep strength, and stability of the microstructure of the PWC-11 sheet appear to be independent of the number of 1900K extrusions performed prior to cold rolling. The microhardness of these single, double and triple extruded PWC-11 sheets also were comparable. The tensile strength of PWC-11 and Nb-1Zr at room temperature and 1350K were comparable.				
14. SUBJECT TERMS Niobium alloy; PWC-11; Creep-strength; Tensile strength; Microstructure; Carbide precipitates			15. NUMBER OF PAGES 11	
			16. PRICE CODE A03	
17. SECURITY CLASSIFICATION OF REPORT Unclassified	18. SECURITY CLASSIFICATION OF THIS PAGE Unclassified	19. SECURITY CLASSIFICATION OF ABSTRACT Unclassified	20. LIMITATION OF ABSTRACT	

**National Aeronautics and
Space Administration**

**Lewis Research Center
21000 Brookpark Rd.
Cleveland, OH 44135-3191**

**Official Business
Penalty for Private Use \$300**

POSTMASTER: If Undeliverable — Do Not Return