

NASA-CR-201491

1111
1112912
0015
60075

Final Report

submitted to

**NATIONAL AERONAUTICS AND SPACE ADMINISTRATION
GEORGE C. MARSHALL SPACE FLIGHT CENTER, ALABAMA 35812**

February 15, 1996

for Contract NAS8 - 38609

Delivery Order 130

entitled

Parabolic Aircraft Solidification Experiments

by

**Gary L. Workman Ph.D.
Principal Investigator**

**Guy A. Smith
Senior Research Associate**

**Susan O'Brien
Senior Research Associate**

**Materials Processing Laboratory
Center for Automation & Robotics
University of Alabama in Huntsville
Huntsville, Alabama 35899**

INTRODUCTION

A number of solidification experiments have been utilized throughout the Materials Processing in Space Program to provide an experimental environment which minimizes variables in solidification experiments. Two techniques of interest are directional solidification and isothermal casting. Because of the wide-spread use of these experimental techniques in space-based research, several MSAD experiments have been manifested for space flight. In addition to the microstructural analysis for interpretation of the experimental results from previous work with parabolic flights, it has become apparent that a better understanding of the phenomena occurring during solidification can be better understood if direct visualization of the solidification interface were possible.

UAH has performed in several experimental studies such as this in recent years. The most recent was in visualizing the effect of convective flow phenomena on the KC-135 and prior to that were several successive contracts to perform directional solidification and isothermal casting experiments on the KC-135. The current apparatus which are available, with some modifications and/or upgrading are the Convective Flow Apparatus (CFA), the Isothermal Casting Furnace (ICF), and the Three-Zone Directional Solidification Furnace.

The next phase of experiments, which have evolved from earlier work on the KC-135 include the particle pushing experiment proposed by Dr. D. Stefanescu from the University of Alabama and his work on modeling microsegregation within a closed system. The parabolic flight experiments utilizing the ICF is useful for verifying the validity of the closed system solidification model currently under development at Tuscaloosa. Further experimental development of parameters required for the space experiments can be obtained through experiments performed on NASA's parabolic aircraft, the KC-135 at JSC and the DC-9 at LeRC. The work performed here relates primarily to the re-qualifying experimental hardware from KC-135 for use on the DC-9. Some modification of the original ICF and ADSF hardware was

required in order to accomplish the experimental objectives. In all cases, only minor modifications are required. The most extensive changes are needed for the Three-Zone Directional Solidification furnace since it has never flown before.

For use on the DC-9 at the Lewis Research Center, data safety packages have been prepared for approval by MSFC and LeRC safety organizations for the experimental apparatus. The current data safety packages have been prepared in conjunction with Dr. Sabayu Sen, a USRA post-doctoral research scientist, who is working with Dr. Stefanescu to prepare these experiments for space. In terms of logistics, it was also necessary that as many of the three experimental apparatus as possible were ready to be flown on the same flights to conserve costs and obtain as much data as possible each trip to Cleveland.

PRIOR WORK

The University has been able to make modifications on the directional solidification and casting furnaces to meet specific goals in previous research efforts. In all cases, we have successfully transitioned the hardware, with minor modifications, to meet the new requirements. For instance, the isothermal casting furnace was initially built as a back-seat addition to the F-104 flying out of Dryden Air Field. When that reduced gravity vehicle became less popular, the apparatus was converted to a KC-135 experiment and has flown successfully many times. A similar approach was taken in designing and building the Convective Flow Apparatus in NAS8-36955, D. O. 93. The objective in that study was to monitor the effect of accelerations on fluid flow as the KC-135 flew a parabolic trajectory to simulate various g levels. That program was highly successful in that the dampening effect of low g was observed during the transition from 1.8 g to 0.01 g using video recording techniques. Another study based on the CFA hardware was to study the convective flow effects on the solidification front in reduced gravity. This study was performed in NAS8-38609, D.O. 47. Consequently, the CFA is very adaptable to being used in this study with some minor modifications.

RESULTS

The University has participated in a number of research activities which required the design and fabrication of experimental apparatus for parabolic flights on the KC-135, including experimental apparatus which were developments of techniques and experiments to study solidification in aircraft parabolic flights. Included in this work was the modification and utilization of the Aircraft Isothermal Casting Furnace, the Convective Flow Analyzer, and initial development of an Aircraft Three Zone Directional Solidification Furnace. These studies have contributed heavily to the mission of the Microgravity Science and Applications' Materials Science Program.

1. Isothermal Casting Furnace Experiments

The Isothermal Casting Furnace was modified very little and a safety data package was prepared for the DC-9 at Lewis Research Center. Two different flights were used in this reporting period to process Al-Cu samples at two different cooling rates. Al-2% Cu and Al-5% Cu were the two alloy compositions studied in these experiments. The samples were prepared at UA by heating the proper proportions of metal using a resistance furnace with pure argon atmosphere and holding the melt over a 20 minute period before pouring into a crucible. The samples were approximately 2 millimeters in length and 6 mm in diameter. For each composition studied in low gravity, a corresponding run was made in 1 g as a ground based sample with approximately the same holding times.

The 1 g samples were homogenized at 680 °C for 40 minutes. The alloy is completely liquid at this temperature. Following the homogenization period, the samples were quenched by introducing helium gas into the bottom of the crucible at a rate to obtain either 9 °C/sec. or 15 °C/sec. A needle valve in the gas transfer line between the pressurized helium tank and the crucible containment provides the ability to control the quench rate.

In order to insure that each sample was quenched under identical conditions in the parabolic flights, we chose to use the third parabola in the flight profile. This time line allowed us to begin heating the sample during the time the DC-9 taxied out to take-off from the airport runway and into flight. The remainder of the time, around 30 minutes, was the time necessary for the aircraft to reach the area for the parabolic maneuvers. An added advantage of using the third parabola is that one usually can sense the pilot's cadence in flying the parabolic trajectories and thus allow sufficient time in low g for the sample to be fully quenched during the low g portion of the parabola. The holding time of 40 minutes at 680 °C was pretty consistent within this series of both low g and 1 g runs.

Cooling curves and accelerometer data was collected by the data acquisition unit and a strip chart recorder simultaneously. The cooling curves indicated that the samples were quenched well into the mushy zone of the phase diagram during low g. A schematic showing the geometry of the original crucible with respect to the sample is given in figure 1 on the next page. The current version of the apparatus has better distribution of the flowing helium over a larger surface area, but basically it looks very similar. The sample geometry, defining the center and the side zones is given in figure 2.

Figure 1. Details of the Isothermal Casting Furnace Containment

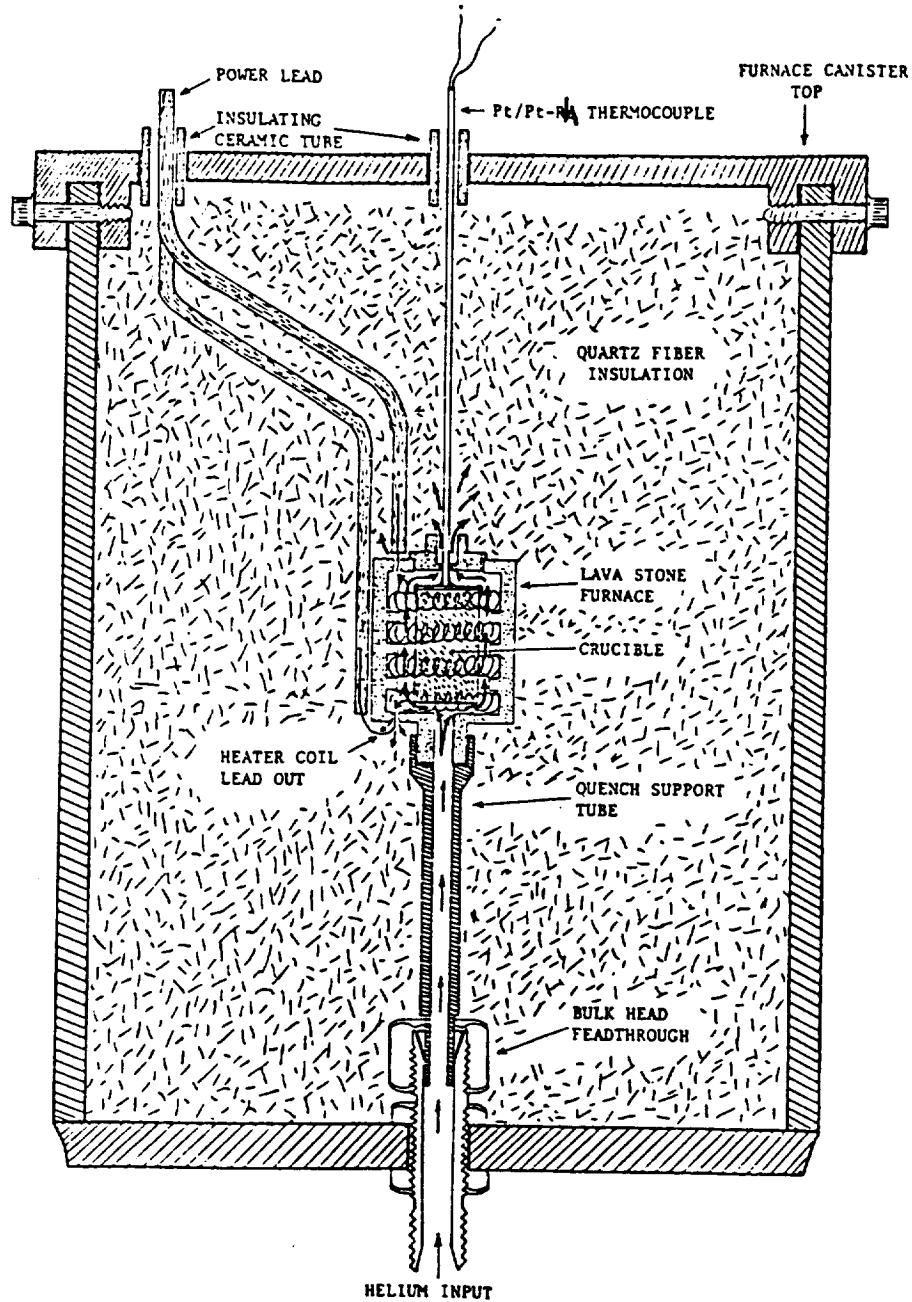
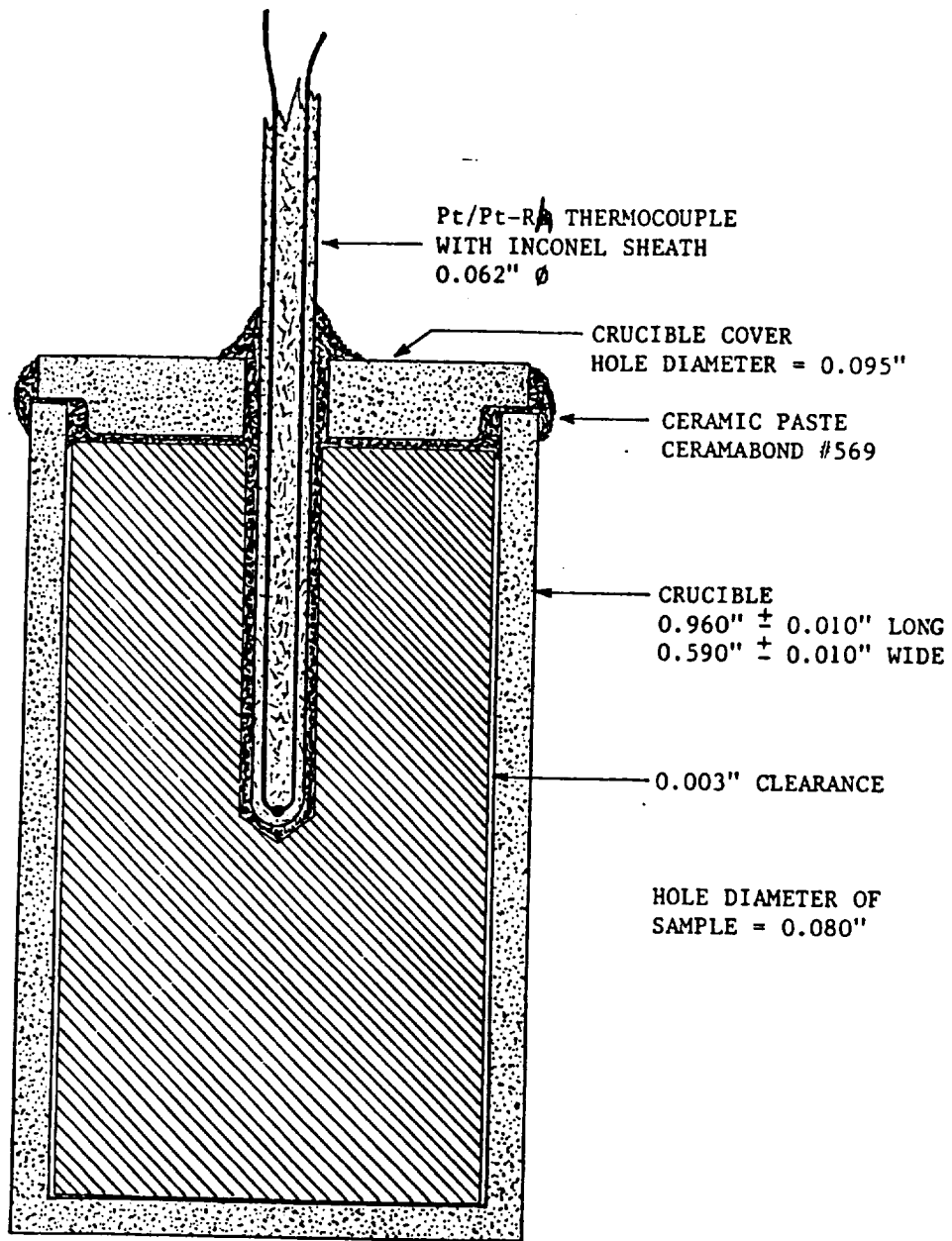

Figure 2. Details of the of the crucible and sample geometry



The preliminary analysis of the microstructures observed shows two different zones, regardless of the solidification method. One zone starts at the wall and projects perpendicularly into the sample; while the other lies between the bottom to the center of each sample. The two zones occur with respect to the rate of heat extraction of the helium flow during quench.

The following pages contain macrophotographs of the samples showing some of the features described in the summary table.

Al-2% Copper

Figure 3. Sample Number I. 1 g sample

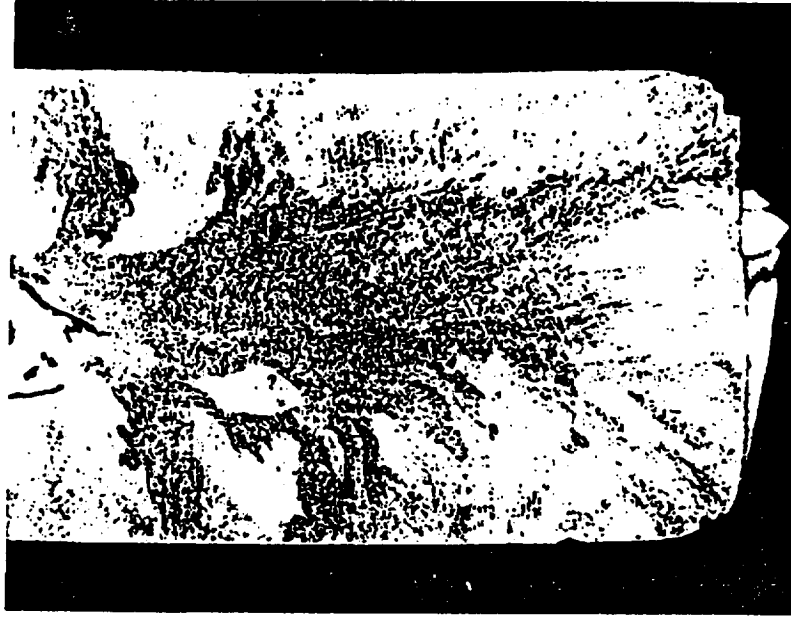
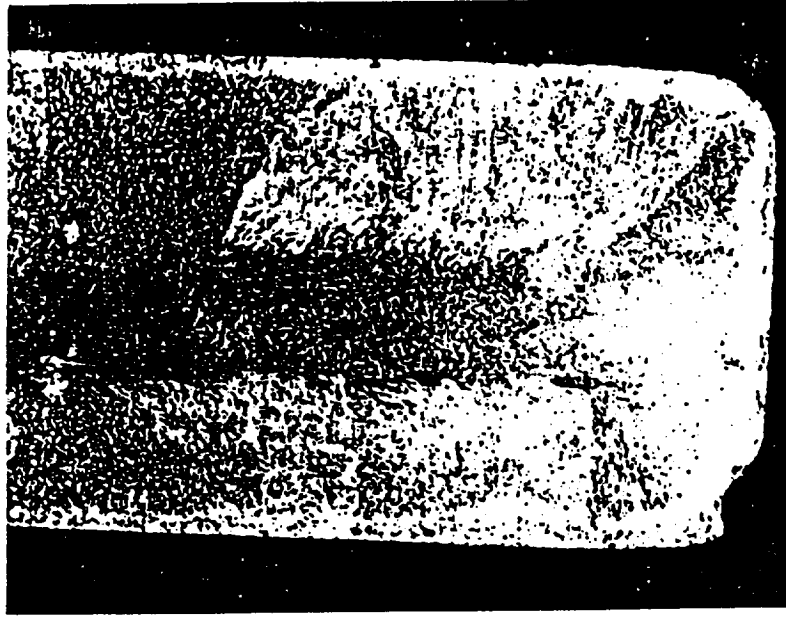

Figure 4. Sample Number III. Low g sample



Al-2% Copper

Figure 5. Sample Number II. 1 g sample



Figure 4. Sample Number IV. Low g sample



The following table provides a summary of the samples analyzed by the University of Alabama up to this date.

Table 1. Summary of microstructure results

Sample No.	Cooling Rate °C/sec	Solidification Condition	Microstructure
I	8.6	ground	Center: cellular, fibrous, oriented Sides: Columnar dendritic, intermediate zone
II	15.0	ground	Center: cellular, fibrous, oriented Sides: Columnar dendritic, intermediate zone
II	9.0	low gravity	Center: cellular, fibrous, oriented Sides: Columnar dendritic, intermediate zone
IV	15.0	low gravity	Center: cellular, fibrous, oriented Sides: Columnar dendritic, intermediate zone

There are certain differences between samples processed in 1 and low g. For instance, the low gravity samples show lesser amounts of grain, a feature that is difficult to quantify at this time.

All samples have cellular and oriented microstructure in the center and columnar-dendritic oriented microstructure on the sides. The combination of reduced gravity and high cooling rate provides a large cellular zone from the bottom of the crucible and very large columnar dendritic from the walls. The microstructural analysis performed by Mr. Jose Leon at the University of Alabama does show that the low gravity sample has less convective flow in the center of the sample and results in a more homogeneous structure with less equiaxed grain and oriented solidification

morphology. It can also be noted that at higher the cooling rates, less differences are observed in comparing macrostructures between 0 and 1 g. These results will be presented by Dr. Stefanescu at a TMS meeting in February, 1996.

2. Particle Pushing Experiments

This task was to develop and perform experiments studying particle pushing during solidification of transparent model materials in low gravity and in the laboratory utilizing the Convective Flow Apparatus. Included within the range of activities as to video tape the solidification and particle pushing behavior of these systems during the two aircraft weeks and provide analysis of the data.

The initial experiments with the CFA demonstrated that the geometry and optical magnification were not adequate for the particle pushing experiments. Several approaches were taken to improve upon the experimental capability of the original hardware. As it turned out, a microscope utilizing a horizontal Bridgeman furnace concept had most of the features required for the experiment. Thus the MSFC system was borrowed and set up as the experimental platform for the particle pushing experiment. The original equipment was certified to fly on the KC-135; however, a new safety data package was prepared for Lewis Research Center to fly on the DC-9. Dr. Sabayu Sen provided most of the contact with Lewis in getting the equipment approved and served as the primary technical resource for those negotiations.

Two flights in the August 20-26 and October 1-5 time frames allowed us to test the microscope and translation furnace for the experiment. The video overlay system used in the original CFA was used for this task. The first set of experiments has a problem in that the high g pull of the aircraft affected the solidification interface in such a way that the interface moved between high and low g's. This motion was obviously not related to the thermal characteristics of the system. For the second series of flights, an attempt was made to stiffen up the microscope slides to avoid a mechanical pressure on the fluid causing the mechanical shift in the interface region. The shift was still observed, although not as badly as the first series.

3. Three-zone Directional Solidification Furnace

The third task included in this effort has been to upgrade the Three Zone Directional Solidification Furnace for flight on either the NASA KC-135 and DC-9 parabolic aircraft. The system had been partially assembled in a previous delivery order, but was not finished when funds ran out. The modifications needed to finish up the system have been started with this effort; however, since primary attentions were focused on the above two tasks, the Three Zone Furnace still requires some additional parts to complete the assembly.

Several of the modifications performed in this time frame has included the temperature controllers and displays for all three zones. Unfortunately this meant dismantling the original controllers and displays and revamping the system for newer versions. At this time the controllers and displays are installed and the major task of wiring up the controllers, displays and actuators is the next task to be performed.

SUMMARY

The work performed in this research has further characterized the parameters which are to be for space flight experiments for the micro and macro segregation in alloys, which will be performed by Dr. Stefanescu's group at the University of Alabama.

In addition, the preliminary definition experiments for a glovebox experiment on particle pushing anticipated for the Shuttle has also been performed. Two series experiments performed on the DC-9 helped to define both the optical system requirements and the directional solidification parameters for the horizontal gradient furnace concept. This information is being used by Dr. Sabayu Sen in working with NASA to define the glovebox experiment for the studying particle pushing phenomena.