

The alignment test system for AXAF-I's High Resolution Mirror Assembly

Mark Waldman

Image Acquisition Systems, Commercial and Government Systems Division  
Eastman Kodak Company, Rochester, NY 14650-3118

**ABSTRACT**

The AXAF-I High Resolution Mirror Assembly (HRMA) consists of four nested mirror pairs of Wolter Type-I grazing incidence optics. The HRMA assembly and alignment will take place in a vibration-isolated, cleanliness class 100, 18 meter high tower at an Eastman Kodak Company facility in Rochester, NY. Each mirror pair must be aligned such that its image is coma-free, and the four pairs must be aligned such that their images are coincident. In addition, both the HRMA optical axis and focal point must be precisely known with respect to physical references on the HRMA. The alignment of the HRMA mirrors is measured by the HRMA Alignment Test System (HATS), which is an integral part of the tower facility. The HATS is configured as a double-pass, autocollimating Hartmann test where each mirror aperture is scanned to determine the state of alignment. This paper will describe the design and operation of the HATS.

**Keywords:** AXAF, HRMA, alignment, testing

**1. INTRODUCTION AND OVERVIEW**

The Advanced X-Ray Astrophysics Facility - Imaging (AXAF-I) will be the next in the series of space-based national observatories designed to address fundamental questions in astronomy and physics. It is the successor to the highly successful Einstein Observatory, flown from 1978 to 1981, which made great contributions to x-ray astronomy. AXAF-I, scheduled for launch in late 1998, will be significantly more powerful than its predecessor with twice the spectral range (0.10 to 10 keV), 10 times the resolving power, and 50 times more sensitivity to faint x-ray energy. AXAF-I is being developed under the technical direction of NASA/MSFC by a broad-based industry team led by TRW, Inc. and including Eastman Kodak Company, Ball Aerospace, and Hughes Danbury Optical Systems (HDOS).

The heart of the AXAF-I telescope is its High Resolution Mirror Assembly (HRMA). The HRMA consists of four nested Wolter Type-I grazing incidence mirror pairs with a 10 meter focal length (Figures 1 and 2). The mirror elements must be positioned and bonded in place during assembly so that they will be in alignment when in orbit.

Assembly and alignment of the HRMA takes place in a vertical orientation in an 18 meter high steel tower located at Eastman Kodak's Building 601 facility in Rochester, NY (Figure 3). The HRMA is assembled from the inside out, starting with the smallest paraboloid (P6) and ending with the largest hyperboloid (H1). One at a time, each mirror is brought into the HRMA structure on a fixture equipped with precision actuators. The mirror alignment is measured with a visible light scanning system and is then adjusted with the actuated fixture. The process is iterated until the errors are driven to zero within the measurement error and adjustment granularity, and then the mirror is bonded in place. When the bond is cured, the fixture is removed from the tower and used for the next mirror.

This paper will concentrate on the visible light system that measures the alignment.

**2. ALIGNMENT REQUIREMENTS**

The HRMA alignment must meet both image quality and line-of-sight requirements.

**2.1 Image quality requirements:**

The image parameters that are affected by alignment are the image position (both lateral and axial) and coma. Table 1 shows the overall alignment requirements; these values are further suballocated to measurement errors and a measured value tolerance.

TABLE 1  
IMAGE QUALITY ALIGNMENT REQUIREMENTS

<u>Parameter</u>	<u>Tolerance</u>	<u>Units</u>
Alignment Error (90% Encircled Energy)	0.25	arcsec
Allocations:		
Lateral Parfocalization Error	0.007	mm
Axial Parfocalization Error	0.007	mm
Coma Radius	0.007	mm

The image position must be controlled because the four images (from the four mirror pairs) must be coincident (i.e., “parfocalized”). The lateral parfocalization requirement is specified directly as the lateral distance from the ensemble weighted average image to the image from an individual mirror pair. Lateral parfocalization is controlled primarily by mirror centering; the tolerance corresponds to a decenter error of 0.0035 mm. The axial parfocalization requirement is specified as the radius of a mirror pair’s defocus image circle at the average image (i.e., a focus error). Axial parfocalization is controlled by the axial mirror position; the tolerance corresponds to a mirror axial position error of 0.03 mm. It is convenient to visualize the parfocalization requirement as a cylinder in space in which all of the mirror images must lie. (The cylinder’s radius is constant for all mirror pairs, but its length for each mirror pair is different based on f/number.)

Image coma is caused by a lateral displacement between the conic foci of the paraboloid and hyperboloid of a single mirror pair (Figure 4). The foci are located at the paraboloid focus, 20 meters from the HRMA. Due to the long lever arm, coma is controlled primarily by relative tilt of the hyperboloid with respect to the paraboloid; the coma radius tolerance corresponds to a tilt error of 0.07 arcsec.

## **2.2 Line of sight requirements:**

The HRMA is required to provide a reference that is coincident with its optical axis within 10 arcsec. This reference (the alignment reference mirror (ARM)) will be used to align the HRMA during calibration testing at Marshall Space Flight Center’s X-Ray Calibration Facility. It will also be used to align the HRMA and the Science Instruments to each other during telescope integration.

## **2.3 Paraboloid Alignment Requirements:**

Because of the optical configuration, paraboloid alignment errors can be compensated by hyperboloid alignment adjustments. The image coma can be corrected by moving the hyperboloid conic focus until it is coincident with the paraboloid focus. The image position can be adjusted without introducing coma by rotating a hyperboloid about its conic focus. However, the range of paraboloid alignment error that can be compensated is limited by the need to avoid vignetting. If the compensating alignments are too large, some of the light collected by the paraboloid will miss the hyperboloid. In order to avoid vignetting, the paraboloids must be aligned to the ARM within the tolerances shown in Table 2.

TABLE 2  
PARABOLOID IMAGE ALIGNMENT REQUIREMENTS

<u>Parameter</u>	<u>Tolerance</u>	<u>Units</u>
Paraboloid Decenter	0.07	mm
Paraboloid Tilt	1.0	arcsec

## **3. HRMA ASSEMBLY APPROACH**

The HRMA is assembled from the inside out; the mirror installation sequence is P6, P4, H6, P3, H4, P1, H3, H1. The sequence was designed to optimize the use of the support equipment and give the earliest possible measurement of a mirror pair (MP6). Once each mirror is aligned, it is bonded in place before the next mirror is installed.

The axial location of each paraboloid is set based on mechanical measurements of the mirror end face with respect to the HRMA center aperture plate (CAP). The position value is determined from the mirror figure data from

mirror polishing (and provided by HDOS who fabricated the mirrors). Data from both the paraboloid and hyperboloid of a pair is analyzed to compute the axial locations that minimize the spherical aberration and place the image at the proper location. Tilt and centering of the paraboloids are set to the ARM axis based on optical measurements made with the HATS.

The axial location of the first hyperboloid (H6) is also set based on mechanical measurements. Once the tilt and centering are set as well (based on optical measurements), this establishes the target image location for the remaining mirror pairs. The other three hyperboloids are set based on optical measurements made with the HATS.

#### 4. ALIGNMENT TEST APPROACH

The optical configuration is a double-pass, autocollimated, Hartmann test (Figure 5) that is based on the technique used by Perkin-Elmer Corporation to align the AXAF-I Technology Mirror Assembly.<sup>1</sup> A narrow laser beam is projected from the Centroid Detector Assembly (CDA), located at the HRMA focal point, to the mirror pair under test. The beam is collimated by the mirror pair, reflected off of the autocollimating flat, and is refocused to the focal point by the mirror pair. The location of the return beam's centroid is measured by a quadrant detector in the CDA. The laser beam is clocked around the annular mirror pair aperture zone and the return spot position is recorded at each clocking position. Once the focal plane data ( $Y_k, Z_k$ ) is collected for each clocking angle ( $\theta_k$ ), it is Fourier transformed to find the coefficients of the equation:

$$(Y_k + iZ_k) = Q_0 + Q_1 e^{i\theta} + Q_2 e^{2i\theta} + \dots + Q_{N-1} e^{(N-1)i\theta} \quad (1)$$

where

$$Q_0 = (Q_{0y} + iQ_{0z}),$$

$$Q_1 = (Q_{1y} + iQ_{1z}),$$

$$Q_2 = (Q_{2y} + iQ_{2z}),$$

.

.

.

$$Q_{N-1} = (Q_{N-1,y} + iQ_{N-1,z}), \text{ and}$$

N = number of test apertures per zone

The three coefficients  $Q_0$ ,  $Q_1$ , and  $Q_2$  provide the necessary information about the alignment of the mirror pair. The  $Q_0$  coefficient provides the lateral position of the mirror pair image, the  $\text{Re}(Q_1) = Q_{1y}$  coefficient is the radius of the double-pass focus circle, and the  $Q_2$  coefficient provides the radius (magnitude and direction) of the double-pass coma circle. These coefficients for each mirror pair are then processed further to determine the alignment error of the hyperboloid being adjusted.

#### 5. ALIGNMENT TEST CONFIGURATION

Figure 6 shows the HRMA assembly/alignment tower facility with the alignment test hardware configuration. Each of the components is described below.

The CDA is held in a five degree-of-freedom (DOF) mount (**mounting platform and translation rail assembly**) that provides X (axial), Y, Z, and  $\theta_y, \theta_z$  positioning. This mount provides the capability to align the CDA axis with the HRMA axis and place it at the HRMA focus. In addition, the large Y axis range allows the CDA to be moved between the 10 meter mirror pair focus and the 20 meter paraboloid focus positions. From the 20 meter paraboloid focus, the light path bounces off of the **lower and upper fold mirrors**, which adds 10 meters to the path length required for paraboloid testing. Both fold mirrors can be adjusted in  $\theta_y, \theta_z$ , and the upper fold mirror can be adjusted in X (focus) as well. All of these adjustments are made remotely from the HATS computer.

The **autocollimating flat (ACF)** is a solid 8 inch thick, 52 inch diameter Cervit mirror. The surface was figured by Kodak's precision optics department, which included ion figuring.

The **ACF mount** provides adjustments in 6 DOF. Three vertical actuators provide height and  $\theta_y, \theta_z$  adjustment. The height adjustment is used only to install the mirror into the tower. The tilt adjustments are used to set the ACF parallel to the ARM, which is necessary in order for the HRMA axis to be parallel to the ARM axis.

Two lateral actuators provide lateral adjustment that is used during the *in-situ* calibration of the ACF (see Section 8). Clacking adjustment is provided by a manually operated bearing that is also used during ACF calibration.

The **alignment aperture mask** (Figure 7) is a full aperture plate that contains circular holes for each test beam position. There are 24 holes for each of the four zones. The hole diameters range from 4 mm (for P6/MP6) to 8 mm (for P1/MP1). The diameters are set to be 0.66 times the radial width of the annular mirror zone. The diameters were selected so that the test does not “see” the ends of the mirrors that might be distorted by end-cut effects. It also provides the capability to accommodate small biases in the mirror diameter. The mask supports the tilt reference indicator at its center.

The **tilt reference indicator (TRI)** (Figure 8) measures the tilt between the ACF and the ARM. It consists of two Graseby model S3700Q electronic autocollimators mounted with their optical axes 180° apart. One autocollimator looks up at the ARM and the other looks down at the ACF. The ACF-to-ARM tilt is equal to the difference between the readings from the two autocollimators. The error in the alignment of the two autocollimators to each other is calibrated (and later backed out) by taking readings with the TRI in both its home position and clocked 180° about the X axis. The TRI mounts in the center of the alignment aperture mask and contains a fiducialized window that is a centering reference for the mask

The **alignment reference mirror (ARM)** (Figure 9), which is mounted to the HRMA center aperture plate (CAP), provides the reference line-of-sight (LOS) axis for HRMA alignment and integration into the telescope. The ARM is a 2 inch thick by 16.5 inch diameter diamond turned and hand polished aluminum mirror with many special areas. The ARM contains:

- A plano central zone (11 inch diameter) on both sides, parallel to 1 arcsec.
- A central 1 inch diameter hole containing a fiducialized window which, with the plano central zone, form the LOS axis reference viewable from either side with a theodolite or alignment telescope.
- Annular spheres that have their centers of curvature on the LOS axis. These centers of curvature identify the initial lateral target positions for the paraboloid and system images during alignment. There are two zones, one with a ≈20 meter radius (at the paraboloid image) and one with ≈10 meter radius (at the mirror pair image). The centers of curvature can be accessed by the CDA by scanning the annular zones.

The **CDA** collects the alignment test data. It is located at the focal point and generates a pencil beam of laser light and clocks it around either the annular mirror pair aperture zone in 15° increments (to pass through the aperture mask holes) or around the annular ARM zone. The return beam (after double pass through the mirror pair via a reflection by the ACF) reenters the CDA and is directed to a quadrant detector by a beamsplitter; the detector determines the centroid location of each image. The set of centroid locations is analyzed by the HATS software to determine the state of alignment. The laser power can be adjusted to accommodate the different transmittance of the mirror pairs (and paraboloids) and mask aperture holes. The CDA and the test sequence is remotely controlled from the HATS computer. The CDA is moved by the translation rail assembly to the 20 meter test position for paraboloid alignment testing. A detailed description of the CDA design and performance is contained in Paul Glenn’s paper “Centroid detector assembly for the AXAF-I alignment test system” also presented at this conference.<sup>2</sup>

The **tilt monitor** measures the absolute ACF tilt with respect to gravity as well as a relative tilt change of the assembly/alignment tower. Each unit consists of two electronic single-axis bubble levels set 90° apart. One unit is portable and is temporarily placed on the ACF surface whenever its tilt to gravity needs to be measured. The other unit is permanently attached to the tower and measures changes in the tower tilt when the tower frame is floated on airbags.

All of the HATS motors and instruments are controlled by the **HATS Control Workstation and software**. The software provides the capability to monitor the instruments (tilt monitors and TRI), define and run automated alignment test sequences, and adjust the component positions (CDA, ACF, and fold mirrors) from a single station outside of the assembly/alignment tower.

The **mirror alignment system (MAS)** is a fixture that contains precision actuators and holds the mirror while it is being aligned. The fixture has six motorized actuators with 0.1 micrometer resolution, arranged in a triple bipod configuration. The mirror position is adjusted using the MAS based on results from the HATS measurements. The measurement/adjustment cycle is iterated until the mirror is in alignment. The MAS is controlled by a dedicated software program that computes the actuator adjustments from the six degree-of-freedom input.

The **HRMA support ring** is the interface between the tower structure and the HRMA. It also supports the MAS during mirror alignment. Outside mounts at three locations provide a manual tilt adjustment capability. Mounts on the inside of the ring provide strain-free support of the HRMA CAP.

## **6. MIRROR ALIGNMENT PROCESS**

When a mirror is installed into the tower for alignment, it is first aligned mechanically to the CAP based on gauge measurements.

Before optical alignment can start, alignment of the HATS components must be checked and, if necessary, adjusted. First, the HRMA CAP must be set level to gravity, which is done by adjusting the HRMA support ring. The tilt measurement is made by first setting the ACF level to gravity according to the ACF tilt monitor, and then measuring the ARM-to-ACF tilt with the TRI. Next, the alignment aperture mask and the ACF rotation axis are centered on the reference ARM axis. Finally, the CDA axis is aligned to the reference ARM axis and the test beam is aimed through the alignment aperture mask holes. These prealignments are repeated at various points throughout the alignment process.

The progression from coarse mechanical alignment to the final alignment tolerances is accomplished in three phases. Figure 10 shows the tolerance progression through the phases. Optical alignment uses the CDA to project the test beam through the system and to measure the location of the return spot centroids.

**Preliminary optical alignment** - At the end of mechanical alignment, the centroid pattern can be up to  $\approx 5$  mm in diameter. Since a returned spot from a single aperture has a diameter between 2 (MP1) and 8 (P6) mm, it is likely that not all spots can be captured by a single detector position. In this phase, the CDA test beam is indexed around the mirror apertures and the internal CDA detector is automatically translated to be centered on each return image. The detector positions are analyzed to determine the alignment error, and the mirror is adjusted with the MAS.

**Intermediate optical alignment** - In this phase, the CDA detector remains at a single location; the test beam is indexed around the mirror aperture and the centroid positions are measured by the detector. Alignment data is also collected for the ARM, which provides the lateral parfocalization target for this phase.

**Final optical alignment** - This phase is similar to the intermediate optical alignment because the stationary detector measures all of the centroid positions. However, data is collected for all previously aligned mirrors which provides the parfocalization target for the mirror being aligned. In addition, calibration factors are introduced to account for ACF surface figure errors and measured CDA errors.

## **7. ALIGNMENT TEST DESCRIPTION**

The process of collecting and analyzing the alignment data is automated in the HATS software. A test sequence is first defined by the operator, which includes which test apertures to sample, the sampling order, the sampling integration time, the CDA laser power levels, and CDA calibration data. The apertures need not be run in order; the capability to "scramble" the order was included to minimize the effect of thermal drifts on the measured alignment. Once defined, a sequence can be run just by selecting it. Test times average 10 minutes per mirror zone when 24 apertures are collected. When a sequence is complete, the data is sorted and analyzed to determine the alignment, saved to a file, and printed. The mirror is then adjusted with the MAS, and the process is iterated until the mirror is in alignment.

## **8. ACF CALIBRATION**

Surface slope errors on the ACF contribute to centroid displacements at the CDA and could be interpreted as alignment errors. Because the slope requirements for the ACF are so tight, the capability to calibrate the ACF in the tower is provided by the HATS. In this process, alignment tests are run with the ACF in several orientations. The data is analyzed to determine the bias in the alignment values due to ACF errors. The measured bias is then automatically backed out of subsequent alignment tests. Further details of this process are described in Tim Lewis's paper "AXAF-I alignment test system autocollimating flat error correction" also presented at this conference.<sup>3</sup>

## **9. PERFORMANCE RESULTS/VETA-II ALIGNMENT**

Engineering tests of the HRMA assembly and alignment process were carried out at Kodak during November, 1994 through April, 1995 using the Verification Engineering Test Article -II (VETA-II). The VETA-II, which is a pathfinder for HRMA assembly and alignment, consists of the elements of the largest mirror pair (P1/H1) assembled to a prime-like HRMA structure in the assembly/alignment tower. Tests showed that the HATS was able to measure mirror tilts with a repeatability of 0.02 arcsec and decenters with a repeatability of 0.5 micrometers. Long term drifts in the image position due to thermal variation in the tower facility was measured at less than 0.5 micrometers per hour.

## **10. CONCLUSIONS**

The HATS is an integrated system of optics, instruments, motorized drives, electronics, and mechanical assemblies that has demonstrated its capability to measure the alignment of the HRMA mirrors within the required tolerances. The software provides an integrated, user-friendly interface that maximizes the efficiency of the mirror alignment process. By using the HATS and the MAS together, the sub-tenth-arcsecond and micron class mirror alignment requirements can be met.

## **ACKNOWLEDGMENTS**

The author would like to acknowledge the team of engineers, designers, technicians, assemblers, and subcontractors who worked together to develop this system.

This work was done on the NASA MSFC AXAF program under subcontract from TRW.

---

<sup>1</sup>N. De Filippis, P. Glenn, and R. Cahill, "Assembly and alignment of the Technology Mirror Assembly," Proc. SPIE 640, April, 1986.

<sup>2</sup>P. Glenn, "Centroid detector assembly for the AXAF-I alignment test system", Proc. SPIE 2515, July, 1995.

<sup>3</sup>T. Lewis, "AXAF-I alignment test system autocollimating flat error correction", Proc. SPIE 2515, July, 1995.

**FIGURE 1**  
**HRMA OPTICAL CONFIGURATION**

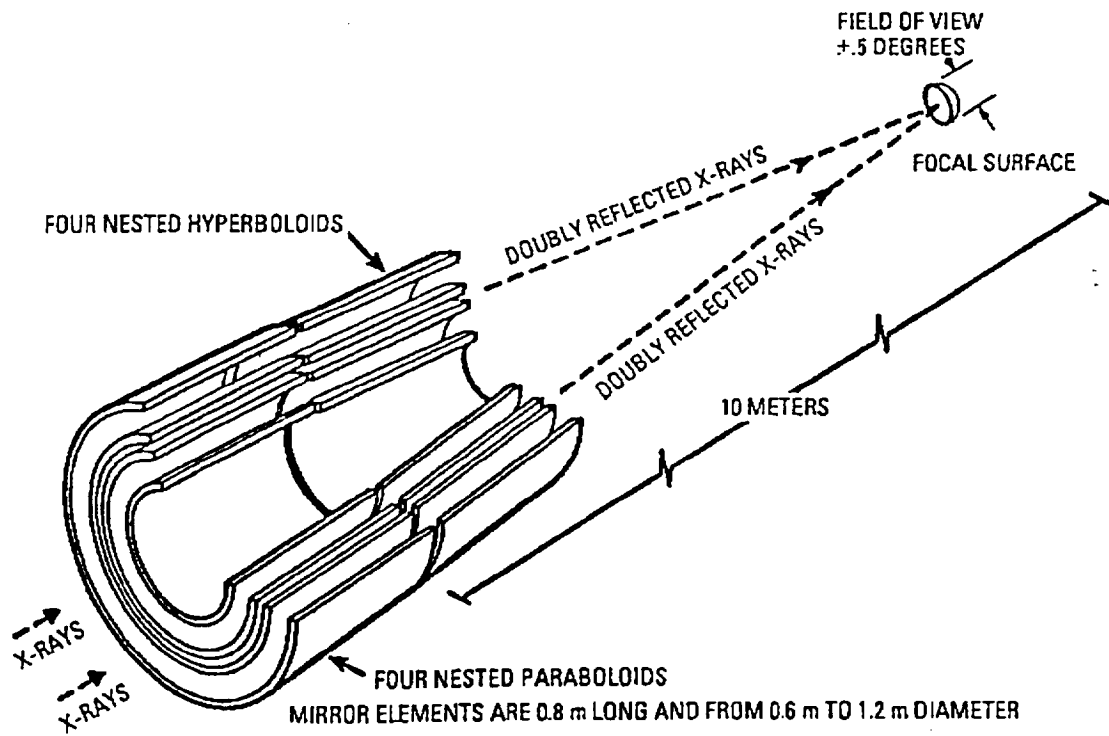

# FIGURE 2 HIGH RESOLUTION MIRROR ASSEMBLY

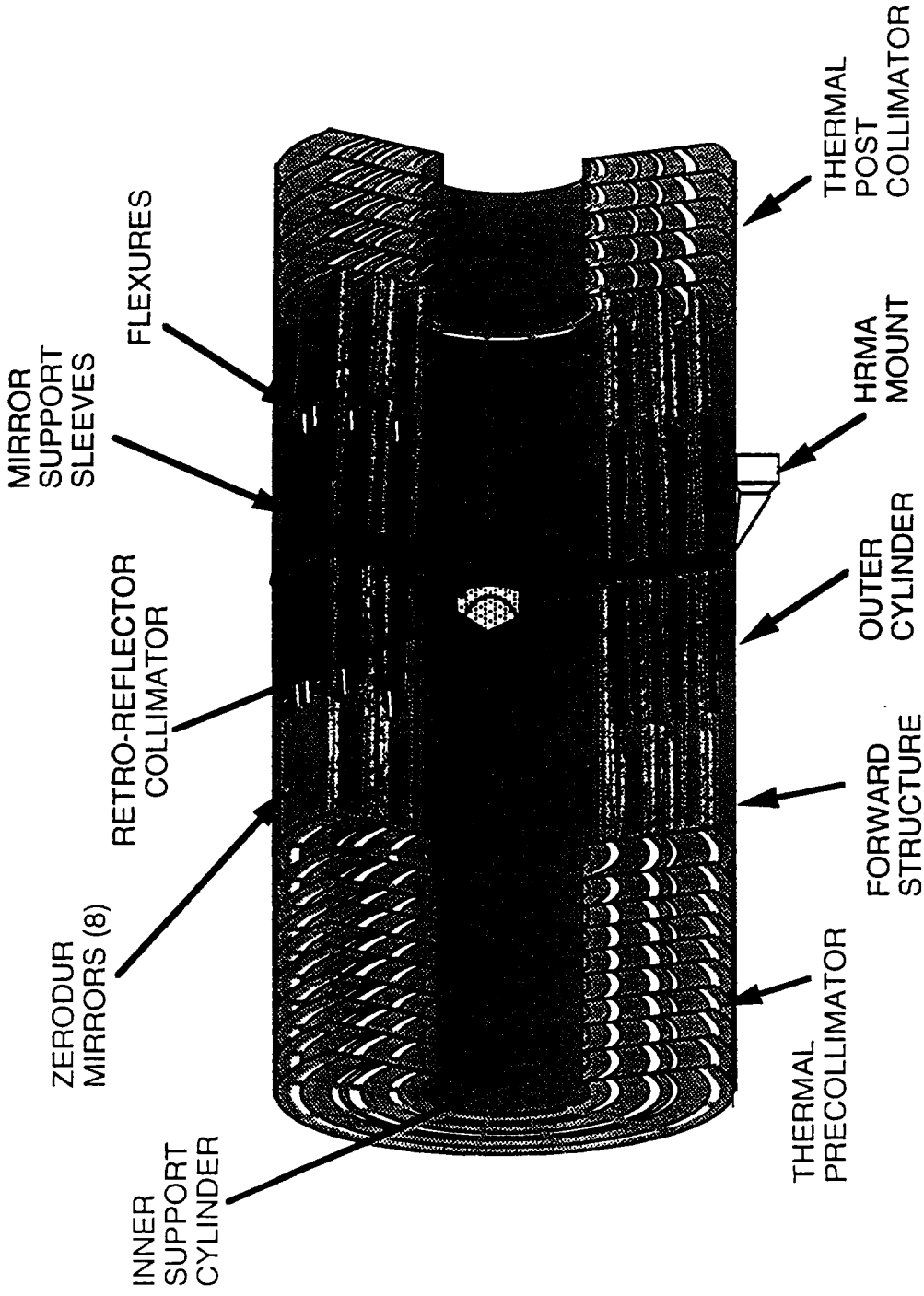



~~HRMA ALIGNMENT AND TEST SYSTEM (HATS)~~

FIGURE 3  
HRMA ASSEMBLY / ALIGNMENT TOWER

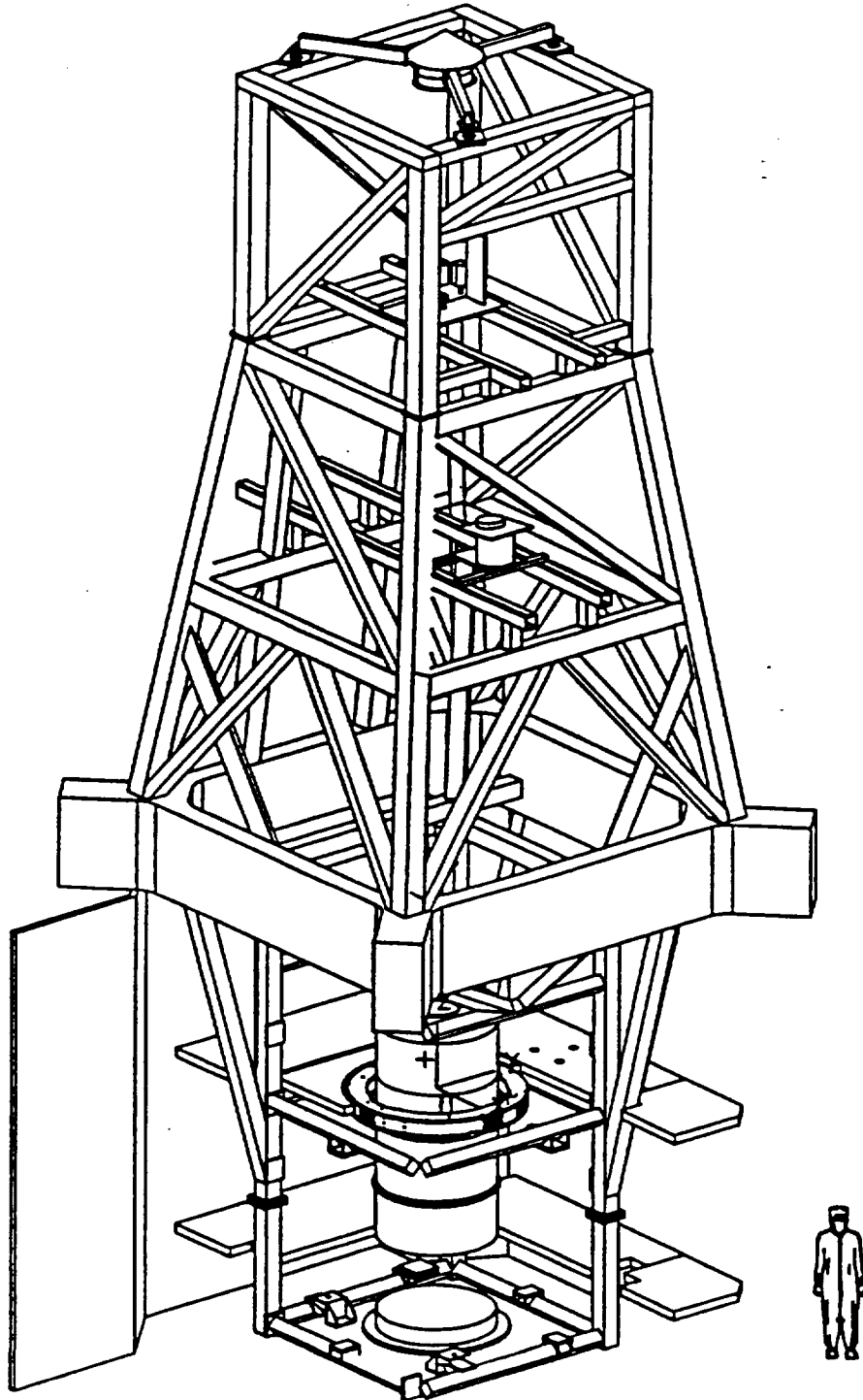
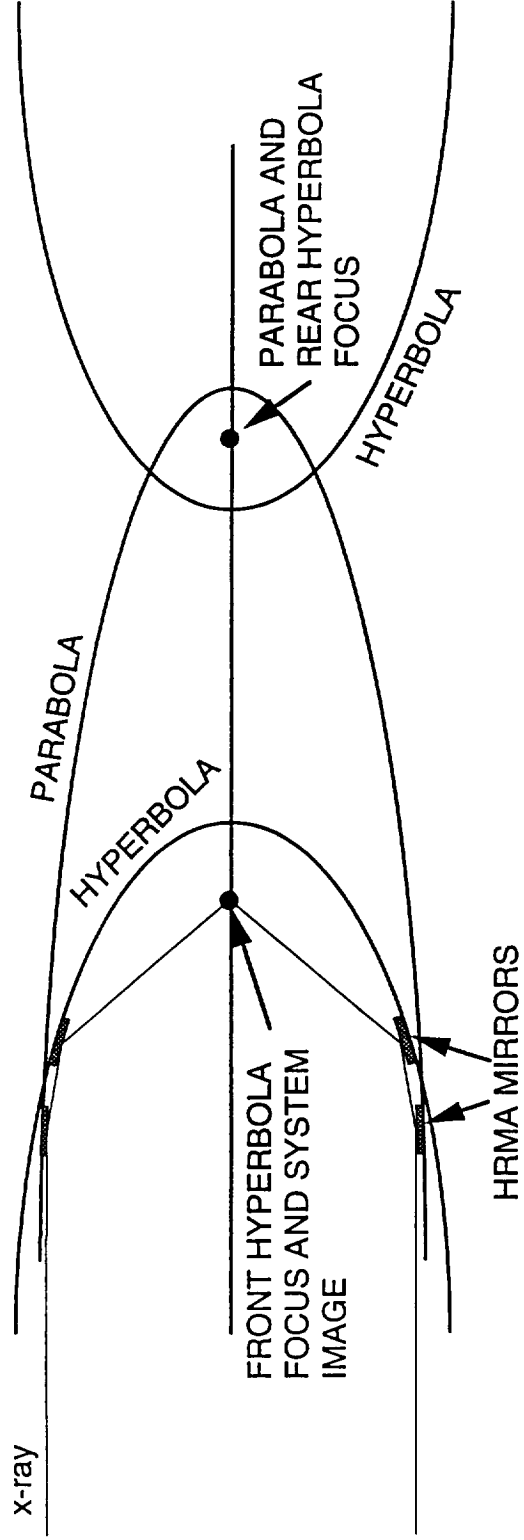

FIGURE 3<sup>4</sup>  
CONIC IMAGING



(not to scale)

Coma in the system image is caused by decenter between the paraboloid focus and the rear hyperbola focus

**FIGURE 5**  
**HRMA ALIGNMENT TESTING APPROACH**

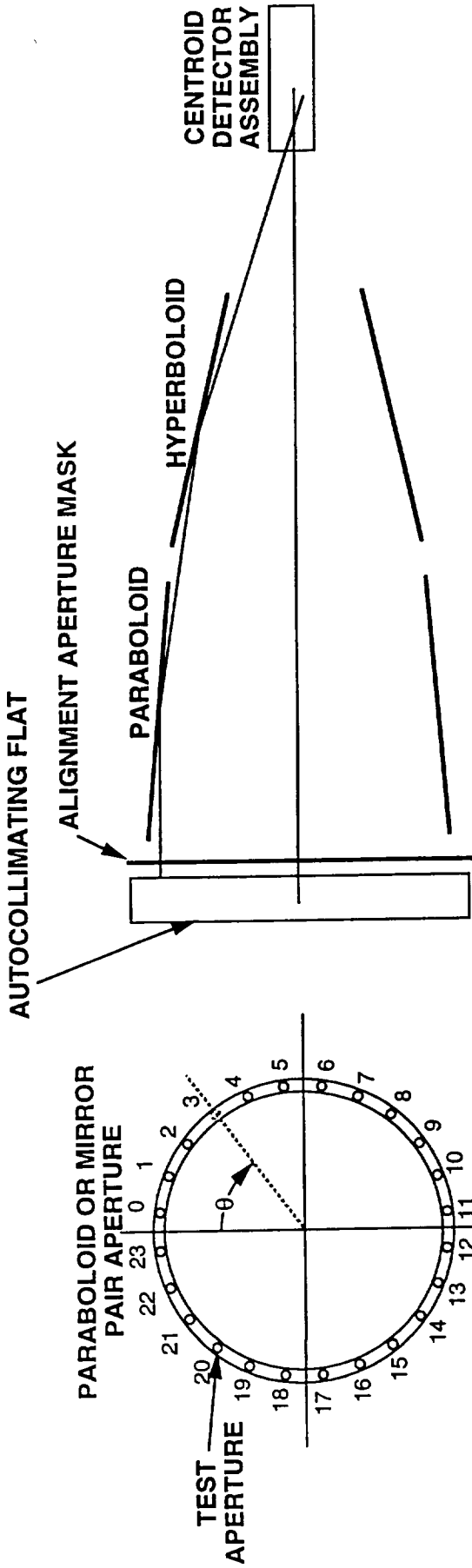

**BEAM INDEXES TO SAMPLE APERTURE AT 24 POSITIONS**

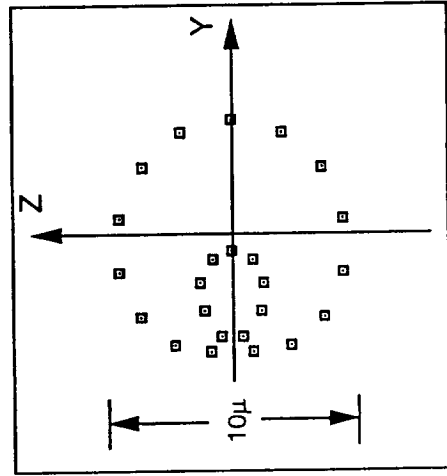

**CENTROID BEHAVIOR IN IMAGE PLANE**  
**(DOUBLE PASS IMAGE AT CENTROID DETECTOR)**

**CENTROID DATA FOURIER TRANSFORM**

- **CENTROID POSITIONS:**  
 $Y + iz = Q_0 + Q_1e^{i\theta} + Q_2e^{2i\theta} + \dots$
- **IMAGE POSITION GIVEN BY  $Q_0$**
- **FOCUS ERROR COMPUTED FROM  $Re(Q_1)$**
- **TILT COMPUTED FROM  $Q_2$**

**FIGURE 6**  
**HRMA ALIGNMENT TEST**  
**SYSTEM (HATS) AND**  
**ASSEMBLY/ALIGNMENT TOWER**

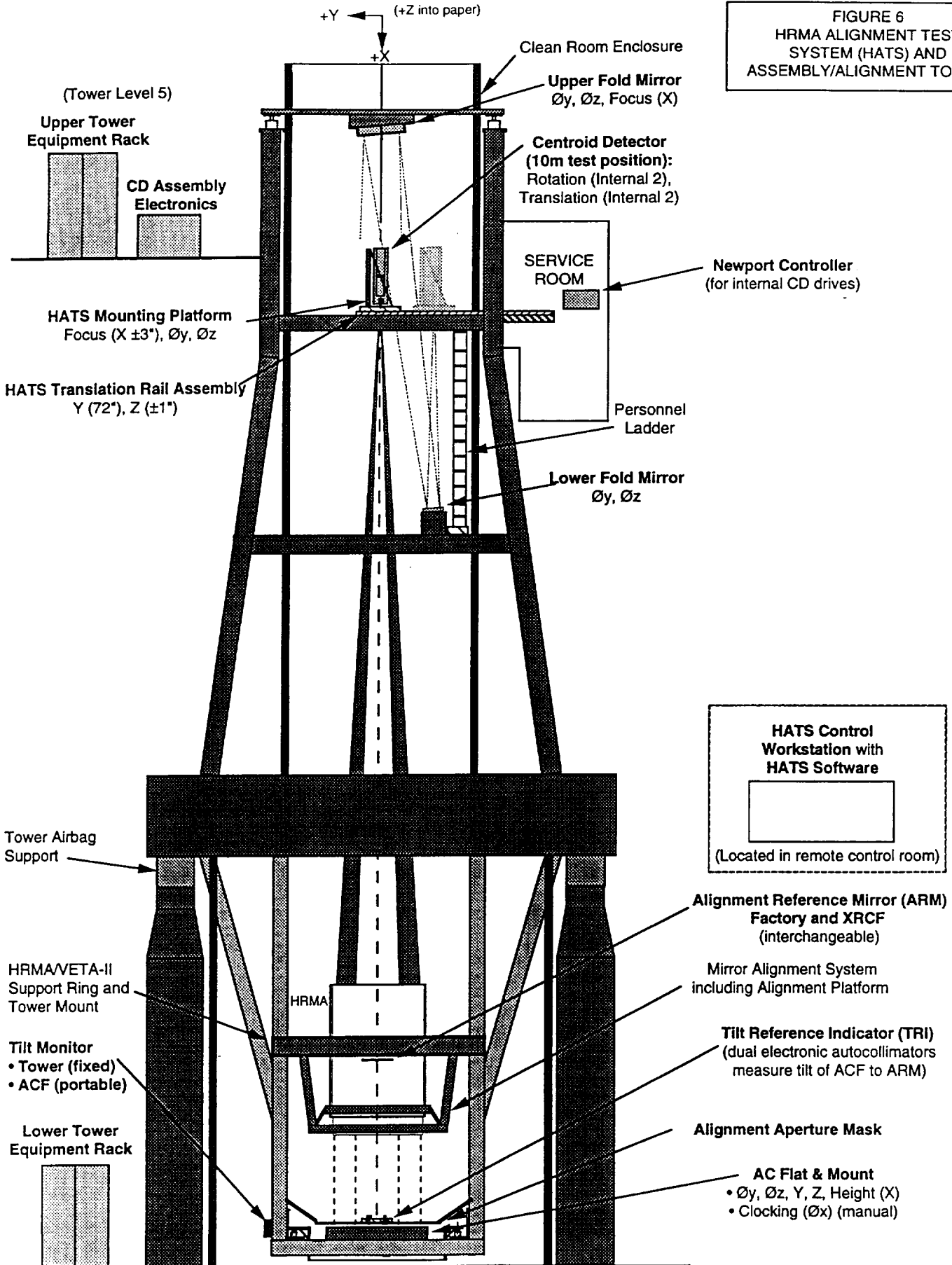

**FIGURE 7  
ALIGNMENT APERTURE MASK**

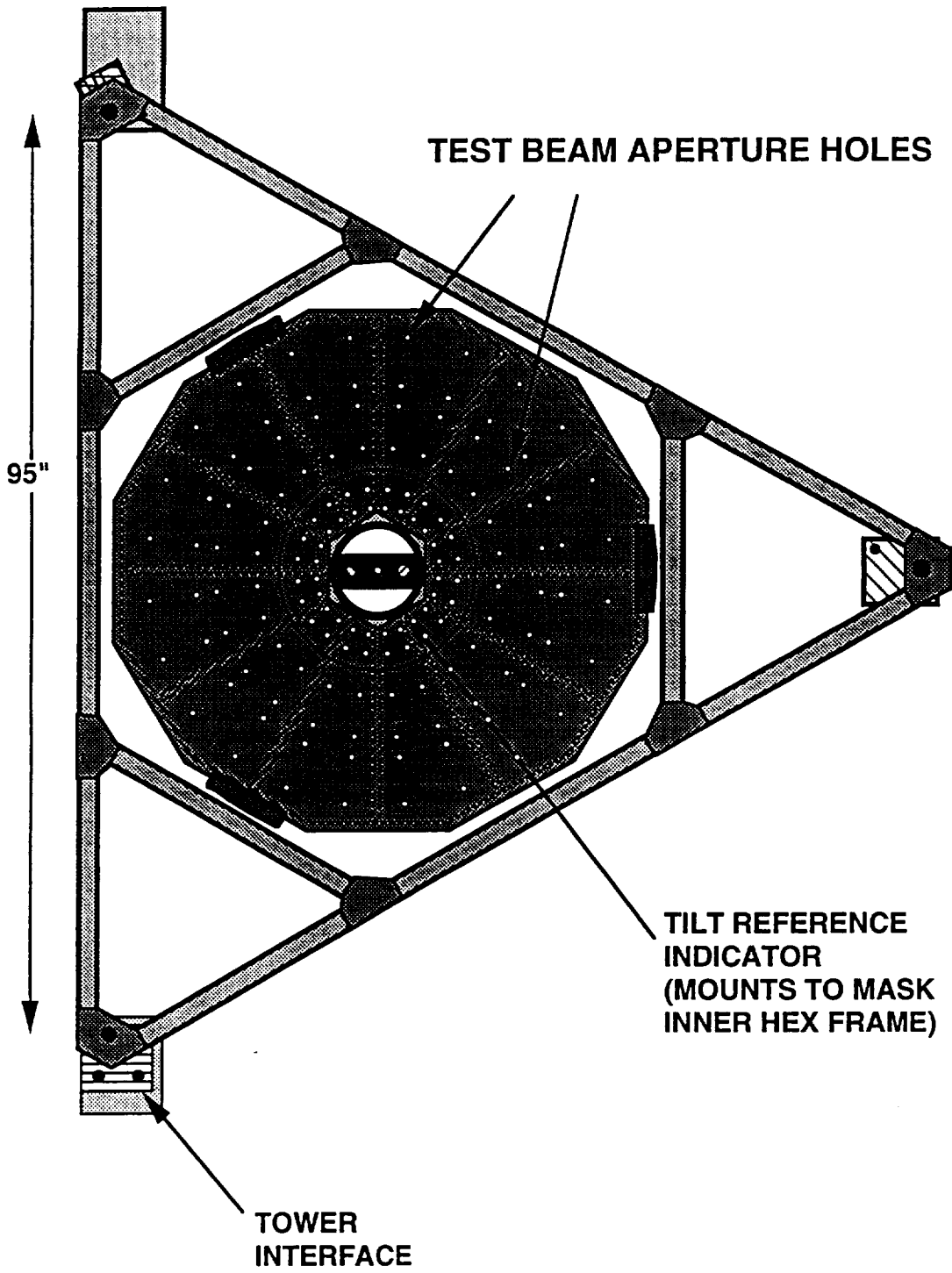

**FIGURE 8**  
**TILT REFERENCE INDICATOR**

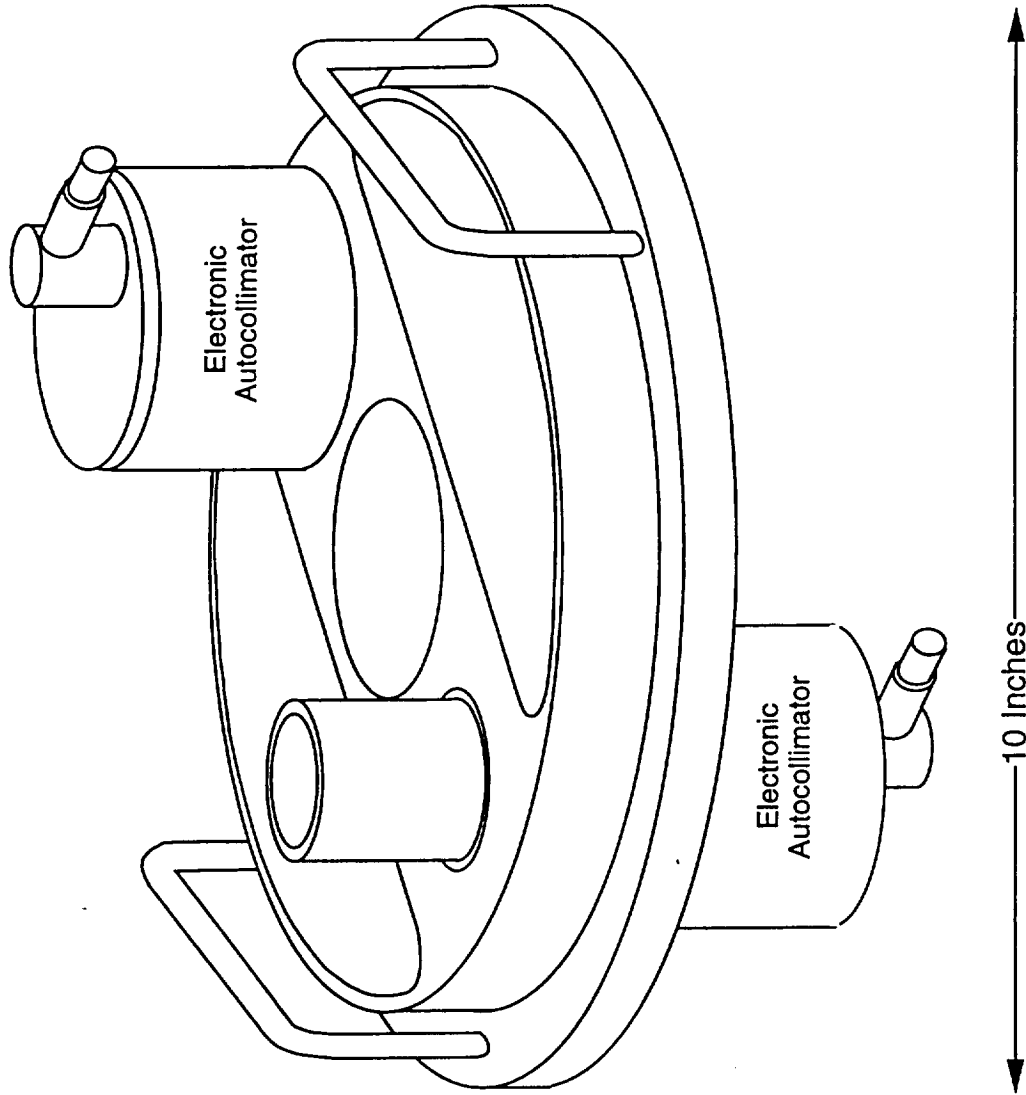

The Tilt Reference Indicator (TRI) measures the tilt between the ACF and the ARM by comparing the measurements from the two electronic autocollimators pointing in opposite directions.

**FIGURE 9**  
**ALIGNMENT REFERENCE MIRROR**

**16.5 INCH DIA. x 2 INCH THICK**  
**DIAMOND TURNED ALUMINUM**

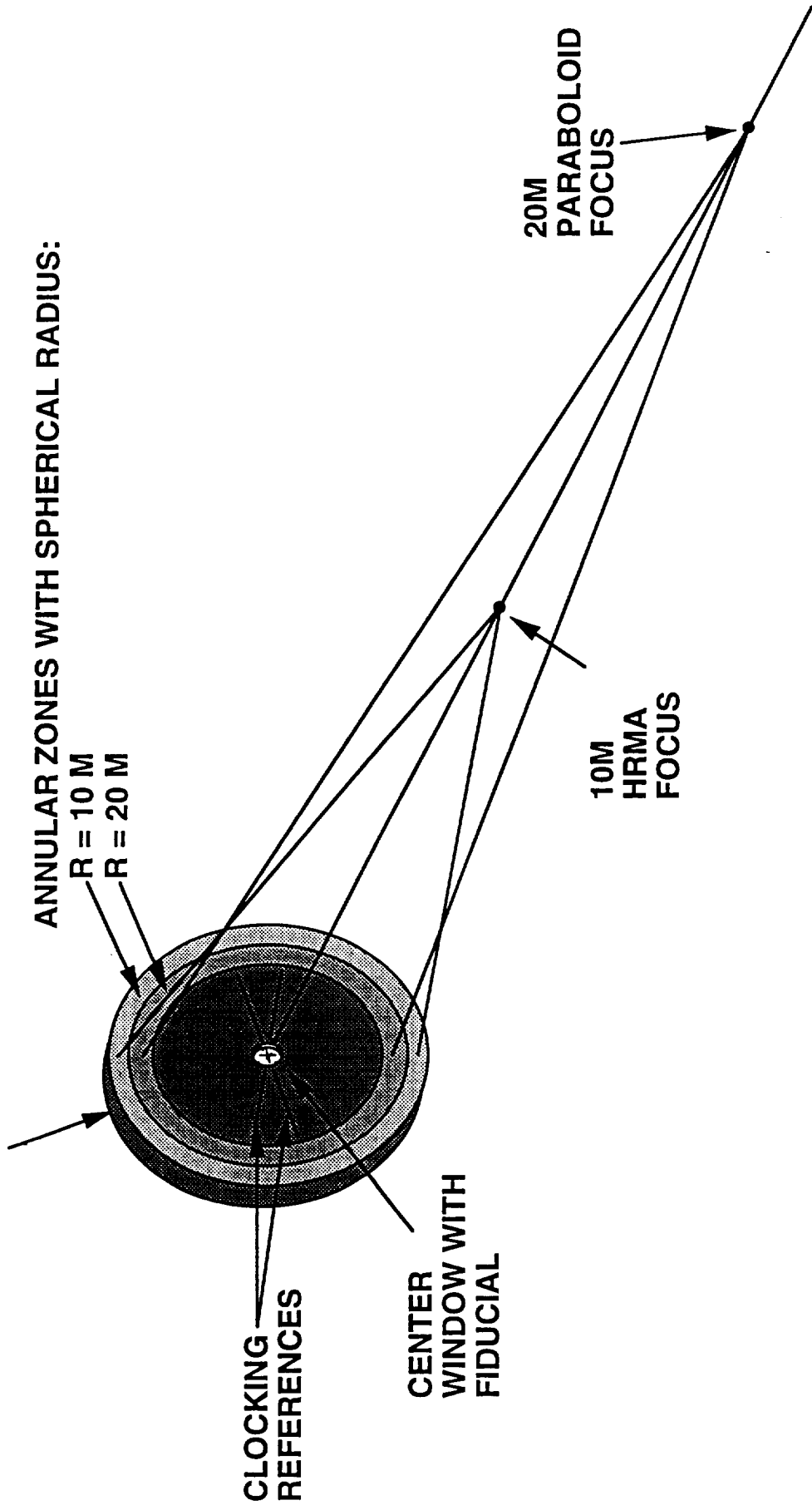

**FIGURE 10**  
**HRMA MIRROR ALIGNMENT PROGRESSION**

