

GPS DISCIPLINED OSCILLATORS FOR TRACEABILITY TO THE ITALIAN TIME STANDARD

Franco Cordara and Valerio Pettiti
Istituto Elettrotecnico Nazionale Galileo Ferraris
Corso M.d'Azeglio, 42 - 10125 Torino, Italy

Abstract

The Istituto Elettrotecnico Nazionale (IEN) is one of the Italian primary institutes which is responsible for the accreditation of secondary laboratories belonging to the national calibration system SNT, established by law in 1991. The Time and Frequency Department, that has accredited in this frame 14 calibration centers for frequency, performs also the remote calibration of their reference oscillators by means of different synchronization systems.

The problem of establishing the traceability to the national time standard of GPS disciplined oscillators has been investigated and the results obtained are reported.

INTRODUCTION

The dissemination of the SI units realized in the primary laboratories down to the users, has always been a matter of concern of all the international organizations involved in metrology or in standardization. The importance of developing, at the industrial level, calibration structures traceable to the national standards and using appropriate measurement procedures, is also recognized and requested in some written standards of the International Organization for Standardization (ISO), namely the ISO 9000 for Quality Assurance Systems and the ISO Guide 25 for Calibration and Test Laboratories^[1].

For traceability to a national standard, that should be guaranteed for any relevant quantity in a production process, it is intended what follows: "the property of the results of a measurement or the value of a standard, whereby it is related to a national standard through an unbroken chain of comparisons all having stated uncertainties"^[2].

The national standard is defined by the same source as: "a standard recognized by an official national decision to serve in a country, as the basis for fixing the value of all other standards of the quantity concerned."

The demand for traceability, that has been constantly increasing worldwide, led some countries to organize networks of accredited laboratories under the label of Calibration Services, consisting of calibration laboratories both independent or included in large companies or educational

institutions. These national calibration services operate surveillance programs to assess the traceability to the national standards of the accredited laboratories. This assures the confidence level of the calibration system and allows to recognize a technical equivalence between the calibration certificates issued by the primary laboratories and the accredited centers, apart from their different uncertainty levels.

At present, the implementation of ISO Standard 10012, concerning the metrological confirmation system for measuring equipment and regarding not only manufacturers but also the suppliers of services, is having a great impact on the Italian calibration market.

This document prescribes, in fact, that all the measuring equipment should be calibrated against measurement standards that are traceable to national or international standards, and that the measurement standards must have a calibration certificate with a statement of uncertainty.

THE NATIONAL CALIBRATION SYSTEM

To organize a network of calibration centers, the national Commission for Metrology of the National Research Council (CNR), established in 1977 the Italian Calibration Service SIT which is managed by a Secretariat where the three primary institutes, namely IEN, IMGC and ENEA, are involved.

The accreditation organization is technically supported by a Committee with experts involved in the accreditation or standardization activity. More than 70 calibration centers have been accredited, up to now, in the different metrological fields according to the SIT and EAL (European Cooperation for the Accreditation of Laboratories) rules, that are based on the ISO and European standards on testing, certification and accreditation activities.

In August 1991 finally, it was established by law the National Calibration System SNT, consisting of the three primary institutes (IEN for electrical quantities, IMGC for mechanical and thermal quantities, ENEA for the ionizing radiations) and of accredited calibration centers, which is under the responsibility of the Ministers of the University and Research and of the Industry and Trade.

The primary institutes main duties consist in studying and realizing the primary standards, in comparing these standards internationally and in disseminating them within the SNT context.

The primary standards maintained in the three institutes became "national standards" by decree in 1993; in this document the realization of each standard is reported and its uncertainty is declared.

The calibration centers agreed by the primary institutes and taking part to the SNT, are secondary level calibration laboratories, selected according to their technical competence and organization and equipped with secondary standards periodically compared to the national standards.

The IEN Time and Frequency Department, that realizes the national standard of time and frequency, is responsible for the accreditation of laboratories in these fields and for the calibration of their reference standards.

TRACEABILITY TO THE NATIONAL TIME STANDARD

The national standard of time is actually realized by a HP5071–High Performance cesium clock, selected among an ensemble of 4, generating the reference time scale UTC(IEN) that is traceable to the international standard UTC computed by the Bureau International des Poids et Mesures (BIPM), by means of the reception of the GPS satellites. An independent atomic time scale TA(IEN) is also generated from the clock ensemble^[3] and, since May 1995, the data are reported to the BIPM. UTC(IEN) time scale is steered on UTC to maintain a long term agreement within $0.5 \mu\text{s}$ or better as recommended in 1993 by the CCDS (Recommendation S5).

The traceability to the national time standard of the secondary standards maintained in the accredited laboratories, can be obtained by means of three different synchronization systems: the passive television method, the coded time signals generated by the IEN and broadcasted by the national radio company RAI and the GPS signals^[4].

The uncertainty level recognized to the centers, at the moment being, can range from 1×10^{-9} to 3×10^{-12} , depending on the reference oscillator selected and on the metrological chain implemented. To establish the traceability for frequency and time, every laboratory must perform daily an agreed number of time interval measurements and periodically send the results to IEN, where the same kind of measurements are performed. Every three months, the accredited laboratory is supplied with a calibration certificate reporting the reference oscillator parameters, the relative frequency departure and the frequency drift in the case of the television and GPS synchronization systems.

A typical uncertainty value obtainable in the evaluation of the oscillator accuracy is of the order of 1×10^{-13} (2σ) for observation times of one month, in the case of the television method and of 2×10^{-14} (2σ) for $\tau = 1$ week in the case of GPS in common view.

In the case of reference oscillators disciplined by standard signals, the frequency offset and the drift of the oscillator are continuously compensated and therefore a different approach has to be followed especially if the time signals used do not disseminate the national standard.

GPS DISCIPLINED OSCILLATION

The use of disciplined oscillators as reference standards also in European calibration laboratories is rapidly increasing due to the wide offer of such equipment on the market featuring, in the case of GPS disciplined system, long term near cesium stability performances using quartz or rubidium oscillators and suitable control algorithms^[5]. Such devices in fact are capable to evaluate and compensate, using a suitable time constant, the long term instabilities of an oscillator, with good short-term features, due to the frequency drift and to the environment variations and to transfer locally the accuracy of the time scale disseminated by the standard signals received.

The use of the GPS time signals in a one-way mode, allows one to trace the local oscillator to the GPS time scale which is kept in agreement with UTC(USNO) within 100 ns ^[6].

As the traceability of the national laboratories to the international time scale UTC is based on the GPS signals measured in the common-view technique and according to a daily schedule organized by the BIPM, it is possible to refer a GPS disciplined oscillator to a national time standard, as requested in the national accreditation systems, through the GPS synchronization results.

A typical block diagram of an oscillator disciplined by the GPS signals is depicted in Figure 1. It is a microprocessor controlled device made of a multichannel OEM GPS receiver card, a local reference oscillator that can be voltage controlled, a time interval counter, a digital divider and phase stepper and a control loop including a filter and a Digital to Analog Converter (DAC).

A Central Processing Unit (CPU) controls all the major functions: collects the time differences between the 1 PPS from GPS and the local time scale, applies a statistical filter to the measured data to reduce the effect of the noise, computes the frequency corrections to steer the local reference and the phase steps to be applied to the frequency divider to keep the local 1 PPS synchronized with the GPS time. Moreover, it allows the user to introduce initialization parameters, to modify the operation mode and to read the operational status of the system through an I/O port.

The oscillator can either be a temperature compensated or an ovenized quartz, a small rubidium or a still better source. Some instruments can also discipline external oscillators already available in the laboratory. The most commonly delivered output signals are a 1 PPS derived from the GPS card and one or more standard frequencies from the disciplined oscillator. Additional information such as the UTC or local time, the antenna coordinates, the local oscillator disciplining process and the time tagging of external events, can be obtained through the display or an interface. In some cases a frequency error multiplier function is also implemented to characterize oscillators to be calibrated.

As the GPS time signals are affected by a degradation due to the Selective Availability (SA), the most critical element to be implemented is the filter that reduces the effects of the SA modulation and allows one to better estimate the oscillator offset and drift. It has been demonstrated^[7], that the decorrelation time of the GPS signals is of the order of 200 s to 300 s and that for longer observation times it is predominant the white phase noise that can be reduced by an averaging process. In Figure 2 are reported the $\text{Mod}\sigma_y(\tau)$ (MDEV) and the $\sigma_x(\tau)$ (TDEV) of the GPS signals received from a 4-channel OEM module and measured versus UTC(IEN), showing this typical behavior for observation times longer than 230 s.

To get accurate evaluation of the oscillator parameters, the time constant of the filter must therefore be higher than the decorrelation time and find a trade-off with the long term instability of the oscillator to be steered. In some devices, different time constants are used to distinguish the oscillator offset and drift from the temperature effects; others are also capable of modeling the oscillator long term behavior and to maintain its output frequency and time within stated limits when the system enters in a holdover mode due to the temporary loss of GPS signals.

The operational sequence of one of such devices can be exemplified as follows. First the GPS multichannel receiver searches for the satellites in view and tracks at least 4 of them to

determine the antenna coordinates. When this operation has been successfully completed, a 1 PPS output signal synchronized to GPS is available and the procedure of evaluation of the local clock error can start. To this purpose, a composite satellite clock obtained by averaging the phase differences of all the satellites tracked, is used to determine the oscillator offset and drift after having applied to the data the statistical filter designed. At this point, the computed correction is converted by the DAC into a voltage applied to the oscillator frequency control input.

A digital phase-stepper can instead perform the corrections needed to maintain the 1 PPS derived from the local oscillator in close agreement with the GPS time scale.

In some instruments, after having reached a steady state condition, only frequency corrections are applied to maintain the time synchronization. The philosophy followed in applying these corrections can be of two types, nearly continuous or periodic, resulting in different short-term instability characteristics.

LABORATORY TEST RESULTS

To get practical knowledge about the performances of this kind of instruments, necessary to solve the problem of their traceability to UTC(IEN), some devices have been tested in 1994 and 1995 at the IEN time and frequency laboratory.

The measurement set-up used is shown in Figure 3; the frequency and time interval measurements have been referred to UTC(IEN) and the differences between UTC(IEN) and the GPS time scale have been determined with the NBS/GPS receiver used for the international traceability. The mean frequency departure between the IEN and the GPS time scales never exceeded 1×10^{-13} during the instruments testing periods.

Four devices from three different manufacturers, labeled in the following as A, B, C, and D, with quartz crystal oscillators or rubidium frequency standards inside, have been checked as regards to their capability to reproduce GPS time, their short and long-term instability, their frequency accuracy and the supplying of information useful to establish a traceability to an external reference standard. All the instruments have been operated in the "time mode" and in all but one case, the reference coordinates of the IEN site have been inserted. The normalized frequency departure values for a period of 54 days, obtained from time interval measurements on instrument A equipped with a high performance rubidium oscillator, are reported in Figure 4 and the corresponding time and frequency instability data in Figure 5. From the frequency data it can be seen that the steering process eliminates the frequency drift; the average value of the frequency offset of the disciplined oscillator corresponds to the difference existing at that time between UTC(IEN) and GPS. The $\text{Mod}\sigma_y(\tau)$ for $\tau = 5$ days, exhibits a flicker floor at the 3×10^{-14} level. In Figures 6 and 7 are reported the same kind of data computed for a period of 22 days on instrument B, having a standard rubidium inside, showing that a lower accuracy and stability are obtained and that sometimes the oscillator frequency momentarily exceeds the specifications. Eight hours of the oscillator frequency departures versus GPS, averaged over the disciplining time constant and supplied every 10 seconds by the instrument via its serial interface, are reported in Figure 8. These data can be collected by the user to check that the

system is operating properly. The frequency and stability results obtained over a period of 28 days with instrument C, a steered ovenized quartz oscillator, are shown in Figures 9 and 10. If we compare these results with those obtained for instrument B, we notice that they are not only comparable, but even better as regards to the frequency accuracy. The last instrument evaluated, identified as D and equipped with a small rubidium oscillator, has been checked also for its warm up characteristic. The frequency results reported in Figure 11, show the effect of the correction of the oscillator offset occurred after three hours from the power-on, corresponding to its disciplining time constant, lowering the frequency error down to the 10^{-11} level. The accuracy specification of this instrument was met after 24 hours of operation. The time error versus UTC(IEN) of instrument D, computed from time interval measurements 12 hours apart for a period of 35 days, has been found equal to $\bar{x} = (0.29 \pm 0.02)\mu\text{s}$. Meanwhile the frequency offset was in the range between -1.8×10^{-12} and 1.9×10^{-12} . The instability data, computed from frequency measurements, are reported in Figure 12. As a comment to these data, that are very alike to those of C, it should be said that: i) instruments C and D come from the same manufacturer and differ only for the oscillator option, ii) in the case of D the position determination was made by the instrument itself, iii) that both devices in the long term correct only the oscillator frequency and not the 1 PPS phase.

To check if the compensation of the oscillator drift is effective, in these devices a user can collect the data of the oscillator control voltage, convert them into frequency corrections and compare with the oscillator long term specifications. This has been verified for instrument D and found compliant.

Concerning the overall delay of the instruments tested, it has been found of the order of $0.2\mu\text{s}$.

ESTABLISHING TRACEABILITY TO UTC(IEN)

Using instrument D, a detailed investigation has been made on the use of GPS as transfer standard for the traceability to IEN of a secondary standard. To this purpose, the time interval measurements performed twice a day between UTC(IEN) and 1 PPS (instr. D) output have been compared with those made by the instrument itself against 1 PPS GPS (2 data a day) and with the UTC(IEN) – GPS data obtained from the averaging of the results coming from the common view schedule (46 data a day). Figure 13 reports the frequency and time instability data of the averaged values of UTC(IEN) – GPS used for this test, showing a slope typical of a white phase noise process for $0.5 < \tau < 3d$. On the residuals obtained by subtracting the three sets of time interval readings mentioned before, taken over 35 days, the TDEV and the MDEV have been computed to find the overall uncertainty limit of this traceability system. The results in Figure 14 prove that it is possible to refer the frequency of a GPS disciplined oscillator to a national standard with an uncertainty of 7×10^{-13} for $\tau = 1$ day that decreases for longer averaging times with a slope of about $-3/2$.

CONCLUSIONS

The problem of establishing the traceability of disciplined oscillators to the Italian reference of time using the GPS signals as transfer standard has been investigated. It has been demonstrated

that this is possible, using adequate measurement protocols, at an uncertainty level of 7×10^{-13} for observation times of 1 day and that it can improve for longer periods. For the instruments of different manufacturers tested, it has been generally found that the long term accuracy declared is very well met, but some discrepancies were found for shorter observation times.

If these kind of instruments are to be used as references in calibration laboratories, a characterization of their short term instability in a metrological laboratory is suggested to help in evaluating the uncertainties of the calibration procedures implemented.

REFERENCES

- [1] V. Kose 1995, "*Dissemination of Units in Europe – Traceability and its Assurance in a National and Regional Context*, *Metrologia*, **31**, 457-466.
- [2] **International Vocabulary of Basic and General Terms in Metrology (VIM)**, 1993, International Organization for Standardization (ISO), Geneva, Switzerland.
- [3] F. Cordara, G. Vizio, P. Tavella, and V. Pettiti 1994, "*An algorithm for the Italian atomic time scale*, Proceedings of the 25th Annual Precise Time and Time Interval (PTTI) Applications and Planning Meeting, 29 November-2 December 1993, Marina del Rey, California, pp. 389-400.
- [4] F. Cordara, V. Pettiti, and P. De Giorgi 1994, "*Time and frequency traceability sources in the Italian Calibration Service*, Proceedings of the 8th European Frequency and Time Forum (EFTF), Germany, 1994.
- [5] J. Kusters, K. Ho, R.P. Gifford, L.S. Cutler, and D.W. Allan 1994, "*A no-drift and less than 1×10^{-13} long-term stability quartz oscillator using a GPS SA filter*," Proceedings of the 1994 IEEE International Frequency Control Symposium, 1-3 June 1994, Boston, Massachusetts, pp. 572-577.
- [6] C. Thomas 1993, "*Real-time restitution of GPS time*," Proceedings of the 7th European Frequency and Time Forum (EFTF), Switzerland, 1993.
- [7] D.W. Allan, and W. Dewey 1993, "*Time-domain spectrum of GPS SA*, Proceedings of the ION GPS-93 Conference, 22-24 September 1993, Salt Lake City, Utah, pp. 129-136.

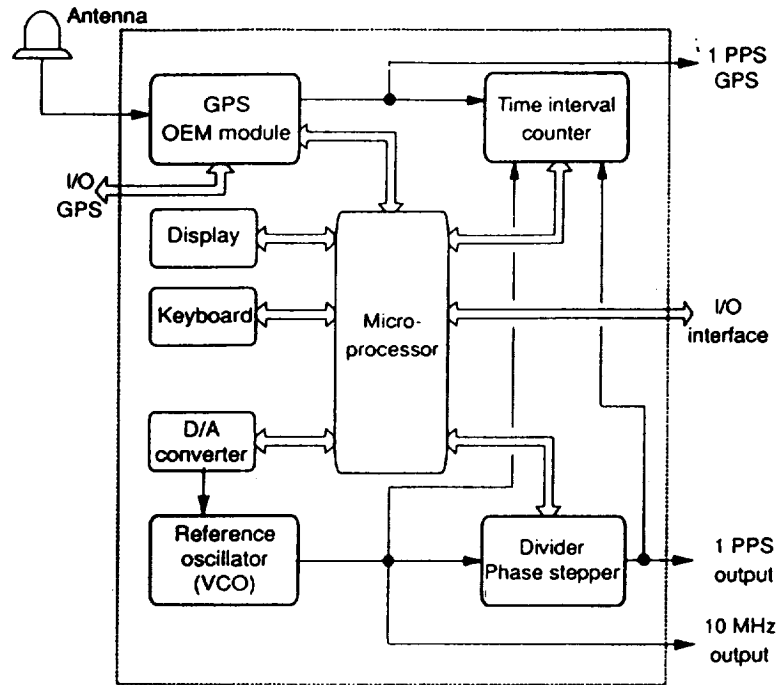

Fig. 1 - GPS disciplined oscillator block diagram

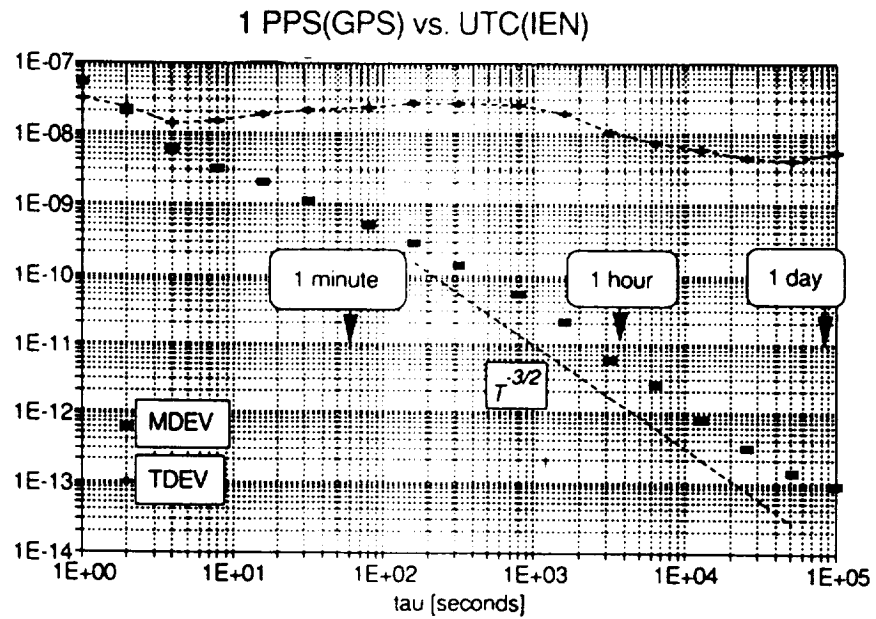

Fig. 2 - MDEV and TDEV analysis of GPS data

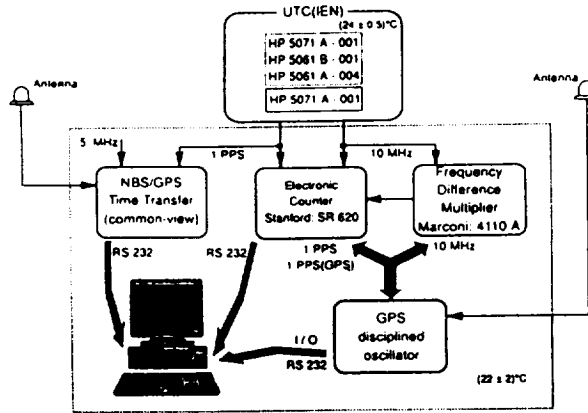

Fig. 3 - Block diagram of the measuring system

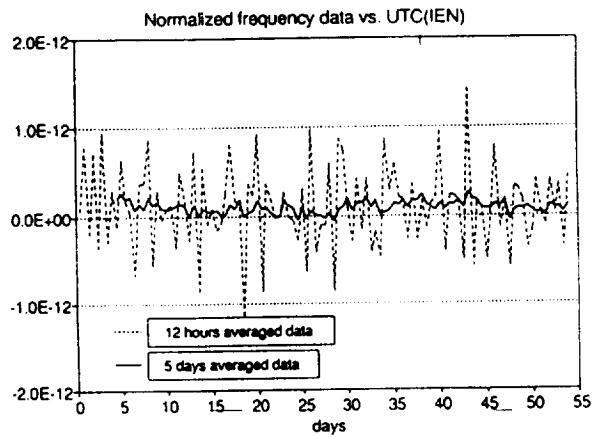

Fig. 4 - Normalized frequency departures of instrument A computed every 12 hours

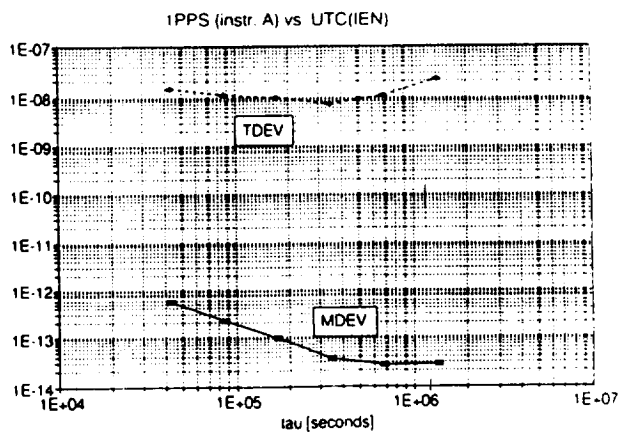

Fig. 5 - Time and frequency instabilities of instrument A

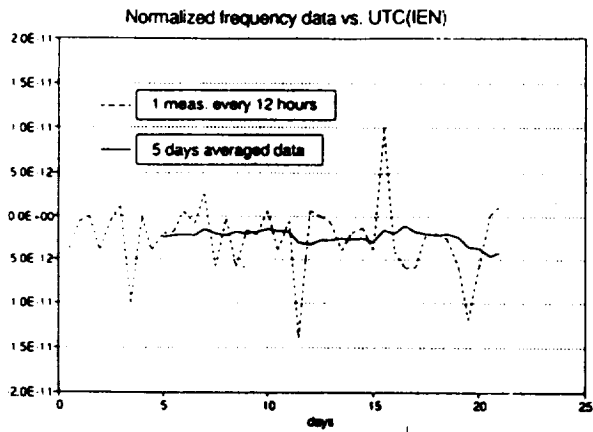

Fig. 6 - Normalized frequency departures of instrument B measured every 12 hours

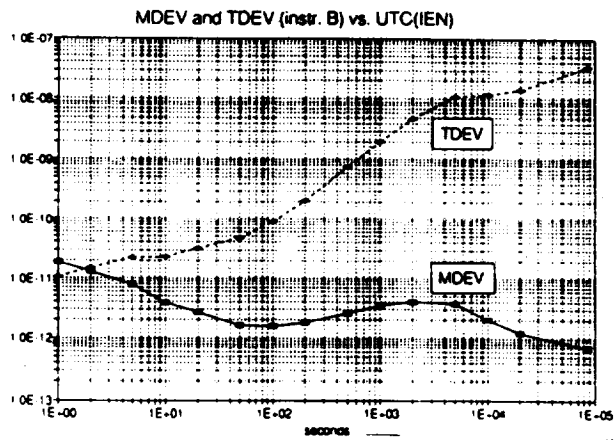

Fig. 7 - Time and frequency instabilities of instrument B from frequency data

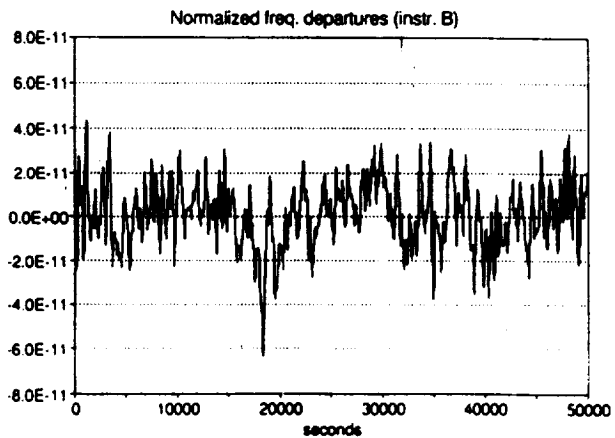

Fig. 8 - Normalized frequency departures versus GPS as given by instrument B

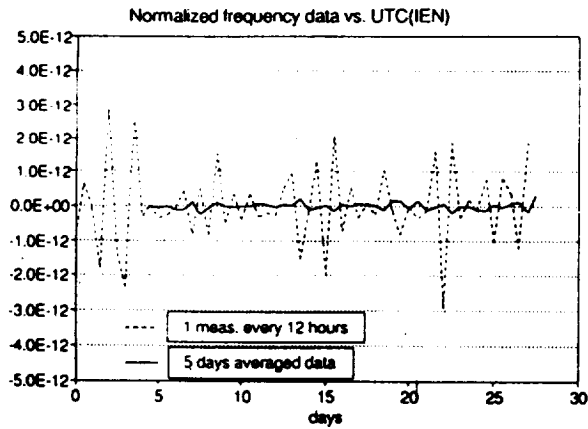

Fig. 9 - Normalized frequency departures of instrument C computed every 12 hours

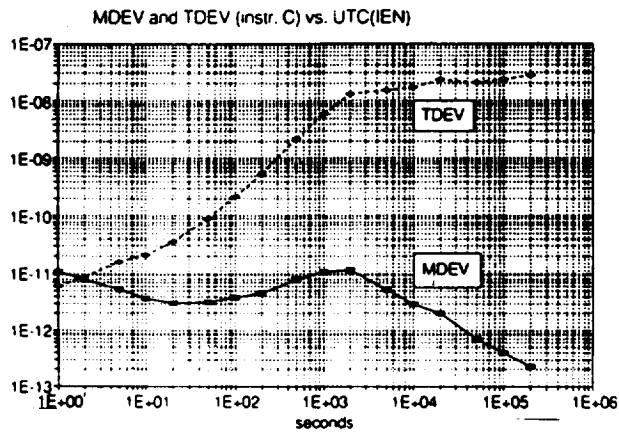

Fig. 10 - Time and frequency instabilities of instrument C

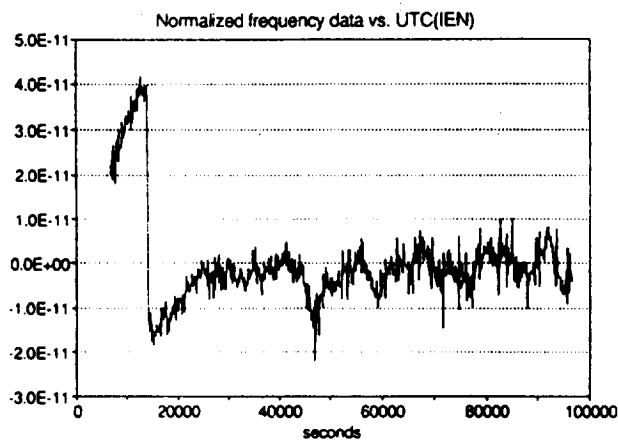

Fig. 11 - Warm up characteristic of instrument D, one measurement every 100 s

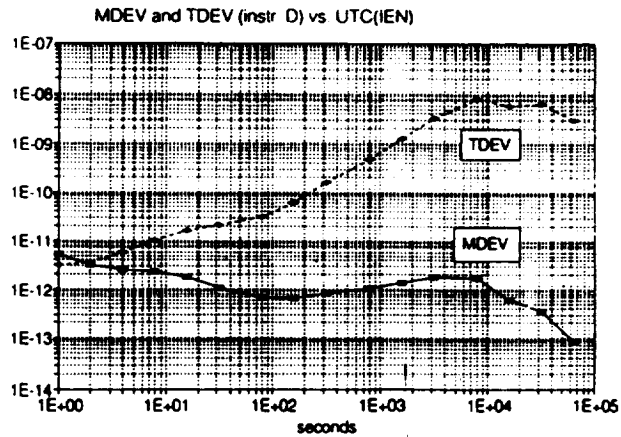

Fig. 12 - Time and frequency instabilities of instrument D

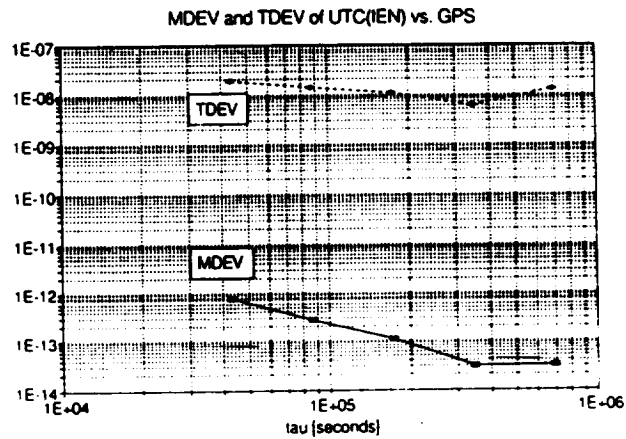

Fig. 13 - Frequency and time instabilities of UTC(IEN) versus GPS from the common-view schedule

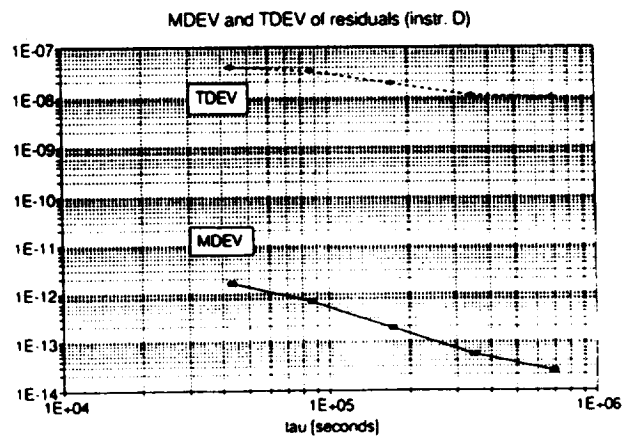

Fig. 14 - Instabilities of the residuals in establishing the traceability chain