

**DATA PROCESSING FOR NASA'S
TDRSS DAMA CHANNEL**

**Christopher C. Long
Dr. Stephen Horan**

— NMSU-ECE-96-005 July 1996 —

DATA PROCESSING FOR NASA'S TDRSS DAMA CHANNEL

**By
Christopher C. Long**

A technical report in partial fulfillment of the requirement for the Degree
Master of Science in Electrical Engineering

Manuel Lujan Jr. Center for
Space Telemetry and Telecommunications

New Mexico State University
Klipsch School of Electrical and Computer Engineering
Box 30001, Dept. 3-0
Las Cruces, NM 88003-0001
(505) 646-3012

July 31, 1996

TABLE OF CONTENTS

EXECUTIVE OVERVIEW.....	4
ABBREVIATIONS	5
LIST OF FIGURES.....	6
CHAPTER 1: INTRODUCTION.....	7
1.1 Space Network Configuration.....	7
1.2 Current Operation of System.....	8
1.3 Space Network Channels.....	9
1.4 Code Division Multiple Access (CDMA).....	10
CHAPTER 2: OPERATIONAL CHANGES TO ACCOMMODATE DAMA CHANNEL.....	15
2.1 Antenna Modifications.....	15
2.2 Change of Data Rate for DAMA requests.....	16
2.3 PN code used for DAMA user.....	17
2.4 Satellite Adjustments Design.....	18
2.5 Design of DAMA receiver and Processing of DAMA requests.....	18
CHAPTER 3: DAMA RECEIVER DESIGN	19
3.1 Doppler Predictor	19
3.2 Carrier Tracking	19
3.3 Receiver Design	21
3.3.1 Demodulator	22
3.3.2 Correlation to DAMA PN code	23
3.3.3 De-Spreading DAMA signal.....	24
CHAPTER 4: SIMULATIONS	25
4.1 Method of Simulations	25
4.2 Simulations and Graphs	26
4.3 Evaluation of Receiver Performance	39
4.4 Recommendations For Future Work	40

CHAPTER 5: CORRELATOR DESIGN	43
5.1 PN Acquisition	43
5.2 PN Tracking	45
CHAPTER 6: DATA PROCESSING REQUIREMENTS	47
REFERENCES	51

EXECUTIVE OVERVIEW

Under a grant (NAG 5-1491) from the National Aeronautics and Space Administration, the Manuel Lujan Jr. Center for Space Telemetry and Telecommunications at New Mexico State University was directed to develop a concept for the addition of a Demand Assignment Multiple Access (DAMA) service to NASA's current Space Network (SN). This work was carried out by various graduate students and professors at the center. Specifically, this paper will outline the design of a receiver for the DAMA channel. Also, an outline of the procedures taken to process the received service request is presented.

This paper will design a simple yet effective receiver for this new DAMA service. The modifications to the (SN) system will be minimal. The post reception processing will be easily accomplished using standard commercial off the shelf (COTS) packages. The result is a random access system capable of receiving requests for service.

ABBREVIATIONS

BPSK	Binary Phase Shift Keying
CDMA	Code Division Multiple Access
DAMA	Demand Assignment Multiple Access
GSFC	Goddard Space Flight Center
LPF	Low Pass Filter
MA	Multiple Access
NASA	National Aeronautics and Space Administration
PLL	Phase Lock Loop
PN	Pseudo-random Noise
SA	Single Access
SN	Space Network
STGT	Second Tracking and Data Relay Satellite System Ground Terminal
TDRSS	Tracking and Data Relay Satellite System
TDRS	Tracking and Data Relay Satellite
USAT	User Satellite of the NASA SN
WSGT	White Sands Ground Terminal
WSC	White Sands Complex
VCO	Voltage Controlled Oscillator

LIST OF FIGURES & TABLES

CHAPTER 1:

Figure 1.1	CDMA Transmission Model
Figure 1.2	Spreading Model
Figure 1.3	Correlation
Figure 1.4	CDMA Receiver Model

CHAPTER 2:

Figure 2.1	Spectrum Two Users with Different Data Rates
------------	--

CHAPTER 3:

Figure 3.1	DAMA Processing
Figure 3.2	Carrier and Phase Tracking Loop
Figure 3.3	DAMA Receiver
Figure 3.4	DAMA Demodulator
Figure 3.5	CORRELATOR
Figure 3.6	De-Spreader

CHAPTER 4:

Figure 4.1.1-4.1.2	Simulation Model
Table 4.1	Simulation (1-5) Parameters
Table 4.2	Simulation (6-8) Parameters
Table 4.3	Simulation (9-11)Parameters
Table 4.4	Simulation (12-14)Parameters
Table 4.5	Simulation (15-17) Parameters
Table 4.5	Simulation (16-20) Parameters
Figure 4.2.1-4.2.20	Simulation Results
Figure 4.3	MA = DAMA chip rate
Figure 4.4	MA = 2* DAMA chip rate
Figure 4.5	MA = 4* DAMA chip rate

CHAPTER 5:

Figure 5.1	PN Acquisition
Figure 5.2	PN Tracking

CHAPTER 6:

Figure 6.1	Operational Flow of DAMA Request
------------	----------------------------------

CHAPTER 1: INTRODUCTION

Currently, scheduling of time on NASA's Space Network (SN) is controlled through a scheduling service at Goddard Space Flight Center (GSFC). If a user satellites (USAT's) controller determines service through the SN is necessary, they will contact GSFC requesting service. GSFC will then process the request and determine if the request can be accommodated. If the service is available, the SN will inform the satellite owner of the pending service and at the appropriate time configure the service. The primary disadvantage in this system is that the satellite cannot itself request service from the SN. With the advent of more powerful computers on board newer satellites, control systems are capable of monitoring the health and welfare of the satellite. These systems can be found on some older satellites as well. The goal of NASA is to incorporate into the SN a service whereby a USAT can request service from the SN when it determines service is necessary. Service can then be scheduled for a standard SN channel. This service will be called the demand assignment multiple access (DAMA) [3].

A proposal has been developed at New Mexico State University that will present a solution to this problem. The goal is to satisfy the requirements while minimizing the complexity of the changes required. This paper will examine the proposed changes in the system required to accommodate the new DAMA service. In particular, this paper will concentrate on the design of a receiver required for the DAMA service requests and the steps required to process the data once a request has been made. To fully understand the scope of the changes the basic operations of the SN will be introduced.

1.1 Space Network Configuration.

The SN consists of three general parts: satellites, ground support, and frequency spectrum [7].

1. The first part is the satellite constellation that consists of satellites each called a Tracking and Data Relay Satellite (TDRS). These satellites are owned and

operated by NASA. The purpose of these satellites is to receive signals from USAT and direct the signals to a common location on the earth. These satellites are located in a GEO-stationary orbit around the earth. Each TDRS has two basic antenna systems. The first is a gimbaled antenna system. The second is a 30 - element phased array system. These will be discussed later in the paper.

2. The second part is the ground-based infrastructure needed to support the TDRS. The primary facility is the White Sands Ground Terminal (WSGT) and the Second TDRSS Ground Terminal (STGT) located at the White Sands Complex (WSC) near Las Cruces, New Mexico. The WSGT has recently been upgraded and is now operational. Located at the WSC are the dishes and receiving equipment required to receive data from the various TDRSs. Another important facility is GSFC. The scheduling system that allocates time on the SN is located at GSFC.

3. The third part of the system is the frequency spectrum allocated to NASA. This includes the carrier frequencies and bandwidth that is exclusive to NASA, as well as the frequencies that NASA shares with other users (i.e. the Ku Band).

1.2 Current Operation of System

The steps to request service on the SN are listed below [8]:

1. The controller of a USAT determines that service by the space network is needed. This type of service typically includes station keeping parameters, system updates, and general health and welfare information. This will also include the standard data dumps. In general, the satellite controller will determine service is needed prior to the time the service is requested. The normal advance time is weeks before service is required. However, the SN does have an emergency service allowing for almost immediate service, usually within five minutes. Emergencies include catastrophic system failures etc.

2. The satellite owner will contact GSFC with the request for service. GSFC will then compare the request with other requests and determine if resources are available for the particular type of service requested. If service is available, GSFC will inform the USAT controller of the pending service. GSFC will then inform the WSC of the scheduled service. The WSC will then use the USAT's parameters to determine the location of the USAT. This information will then be used to determine the Doppler offset that will affect the transmission carrier frequency. The WSC will at the same time inform the USAT via a forward link of the requested service if a return link was requested. WSC will then take appropriate measures to establish the necessary link at the time the service is scheduled as well as configuring the TDRS's and the receivers based on the calculated parameters.

3. The satellite will then transmit its data via a TDRS, if a return service is requested, based on the configuration that the ground station has dedicated to the satellite.

4. The WSC will receive the satellite's information. This information is either directly passed to the USAT owner in real time, or the information is stored on some type of electronic media and then sent to the USAT owner. At no point during this service is the WSC permitted to review any of the data being sent by the USAT.

1.3 Space Network Channels

The SN consists of 3 basic channels used for transmission. These are the K-band Single Access (KSA), the S-Band Single Access (SSA), and the S-Band Multiple Access (SMA). Transmission on the KSA and the SSA channels is a Time Division Multiple Access based configuration. That is, each user has a specific time slot allocated for transmission. Once the time has expired, another user will broadcast during its allotted time and so on. These times are dictated by the SN via the scheduling system. In this

system, the gimbaled antennas on the TDRS are used to physically point at the desired USAT. The mechanical pointing information is controlled via a forward data link to the TDRS by WSC. This information is transmitted along with other operational parameters. The MA portion of the system is a Code Division Multiple Access (CDMA) based design (see sec 1.4). Multiple users will broadcast using the same carrier frequency. However, each user spreads its data with a unique pseudo-random code (PN code). This enables the receiver to decipher the users based on the PN codes. (This will be discussed in detail later). The MA system utilizes the phased array antennas on one of the TDRS. The method of pointing is done electronically rather than physically. The transmission technique used is Binary Phase Shift Keying (BPSK). The data is actually sent via BPSK on both an I and Q channel and therefore is a QPSK signal. This allows for the same data to be sent on the I and Q channels for redundancy or two independent sets of data can be sent. [7]

1.4 Code Division Multiple Access

CDMA is a method of transmission where all the signals use the same carrier frequency to transmit and share the same frequency spectrum. Different users of the system are separated not by time or frequency, but by a pseudo-random noise code. Each user will spread its data with a unique PN code. A PN code is of finite length that will repeat on regular intervals [6]. These codes have specific properties and will be discussed later in the paper.

The rate of the PN code is called the chip rate with each code bit referred to as a chip. Generation of a PN code is done by using a shift register (see Figure 1.1). The register is tapped at different locations and then summed to generate an output. The tap settings and the initial value in the register determine the PN code [6].

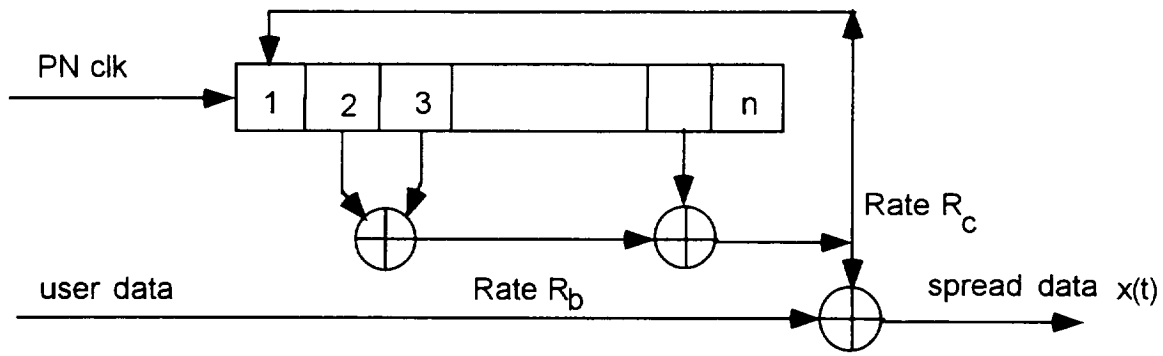

Figure 1.1 Spreading Model

The number of chips before the code repeats is called the code length (L). This length is based on the number of bits the shift register stores. The maximal length of the code is defined as

$$L = 2^n - 1$$

where n is the number of bits in the shift register [6].

The total number of users N that may share a channel is a function of the data rate (R_b) and the chip rate (R_c). The maximum number of users N_{max} is defined as

$$N_{max} \approx 0.2 * (R_c / R_b)$$

The rate at which the data is spread is a function of data rate versus the rate of the PN code. The amount of spreading, S_r , is therefore defined by

$$S_r = \text{chip rate} / \text{data rate} = (R_c / R_b)$$

which determines the number of chips per bit. Therefore, each data bit is spread by S_r chips of the PN code. This is generally referred as the processing gain of the code. The process of spreading the data is done by modulo 2 adding the data with the PN code at a rate greater than the data rate. The resulting waveform has a data rate equal to the PN

code rate. The system is said to be spread because in the frequency domain the higher the data rate for digital data the larger the first null. The basic transmission model for CDMA systems is shown in Figure 1.2.

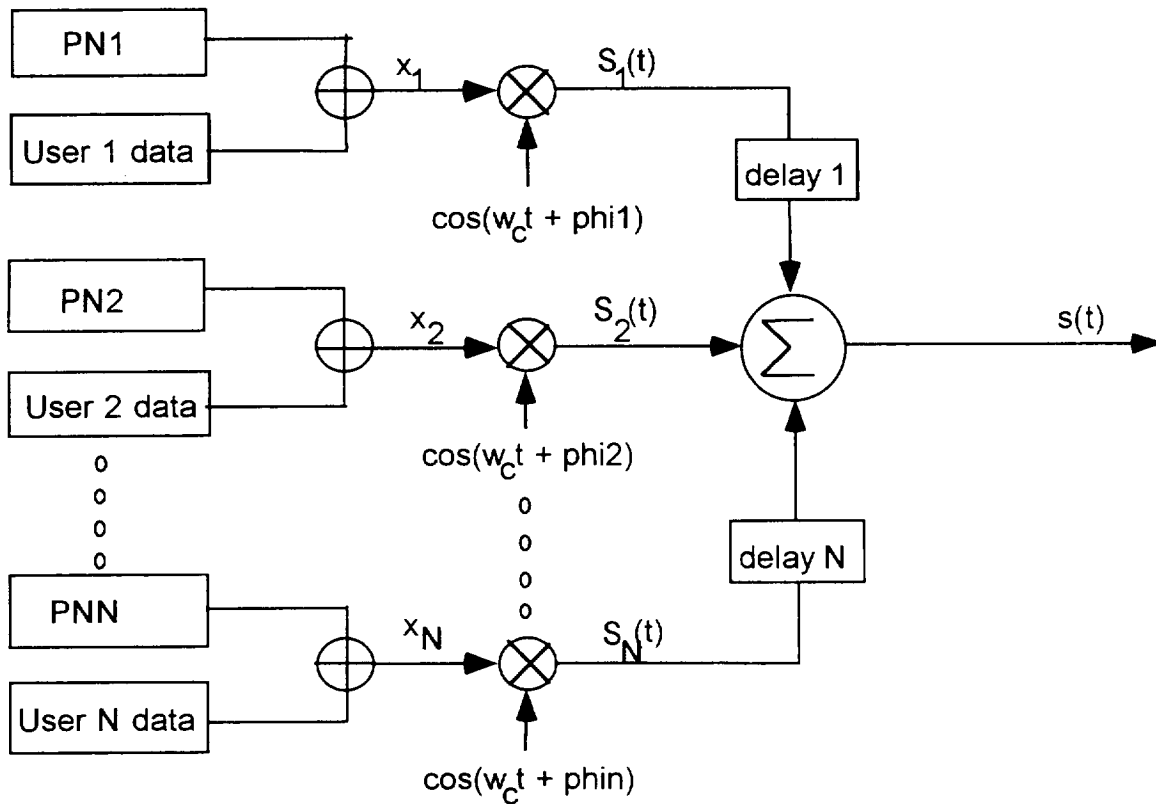

Figure 1.2 CDMA Transmit Model

The system consists of N USAT each at a different physical location relative to a TDRS. The various delays illustrated in the figure represent the each user requesting service at a different time. The probability of two or more users requesting at the exact time is very small and not worth considering. Each user will have its data spread with a unique PN code. The result of each modulo 2 addition of data with a PN code is called $x_n(t)$. Each user will then modulate the spread data onto a carrier frequency common to all MA users. In Figure 1.2, the method of summing all N users is done to show the receivers view of

the incoming signal. In reality, the signals are not added they are simply sharing a common frequency spectrum. Therefore, they all are sharing the same transmission channel. The resulting signal at the input to the receiver can be defined as;

$$s(t) = \sum_{n=1}^N s_n(t) * \cos(w_c(t+t_k))$$

where w_c is the carrier frequency of the CDMA channel and t_k represents the various time delays of each of the N users.

Thus, to demodulate the signal $s(t)$ the receiver first brings $s(t)$ back to baseband and filters the signal. Now the receiver must recover each user from the signal by de-spreading the signal with a particular PN code. The ability to recover each individual user depends on the correlation property of PN codes. The correlation of digital data and a PN code is defined by

$$R(m) = \sum_{d=1}^L r(d)pn_N(d-m)$$

where r is the received signal at baseband, and pn_N is the code used to spread one of the N ($N \leq N_{max}$) users in r [4]. Figure 1.3 illustrates the correlation of digital data. When the two are matched, the correlation is maximized. However, if pn_n is shifted by one chip the correlation becomes very low. The correlation will occur at the code length L divided by the chip rate R_c (i.e. L / R_c) [4].

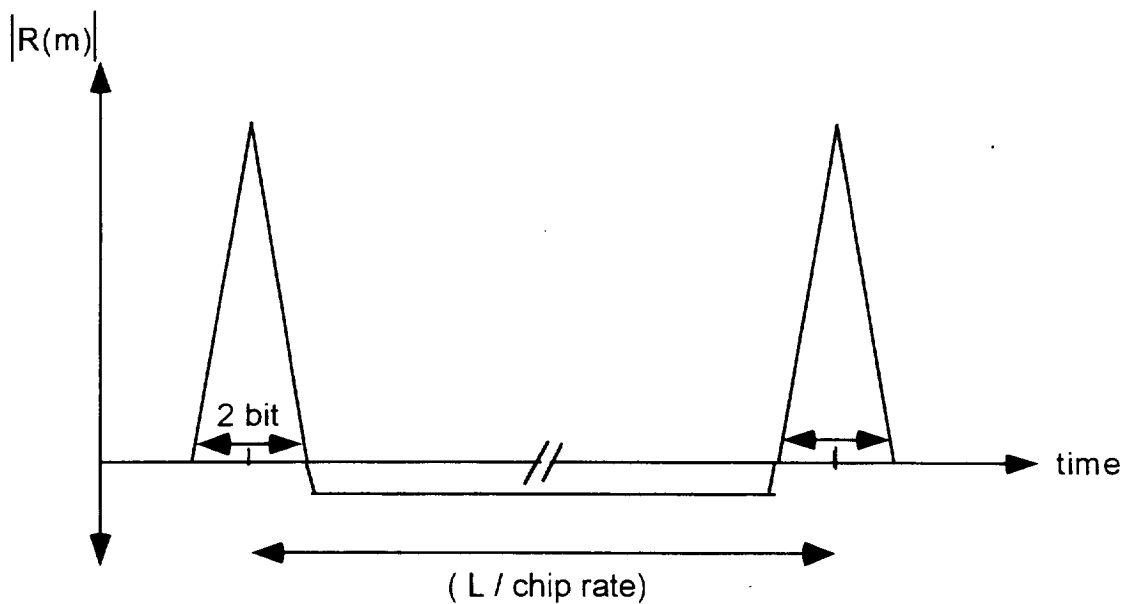

Figure 1.3 Correlation

The processes of despreading the received signal is the inverse of the spreading process. This is due to the fact that if data (d1) is modulo 2 added to some data (d2) and then modulo 2 added to the same data (d2) the result will be (d1). The receiver will work on this principle.

The received signal is first demodulated and low pass filtered (LPF) to bring the waveform back to baseband. The receiver cross correlates the received signal with an exact replica of a particular users PN code [6]. As shown above in Figure 1.3, the result will be maximum only when the two are matched, otherwise the result produces a very low signal. Once correlation is obtained, the de-spreading will begin by modulo 2 adding the received signal with the particular pn_N code used in the correlation.. The receiver will perform this operation for each of the N users on the channel. The basic receiver configuration is shown below in Figure 1.4

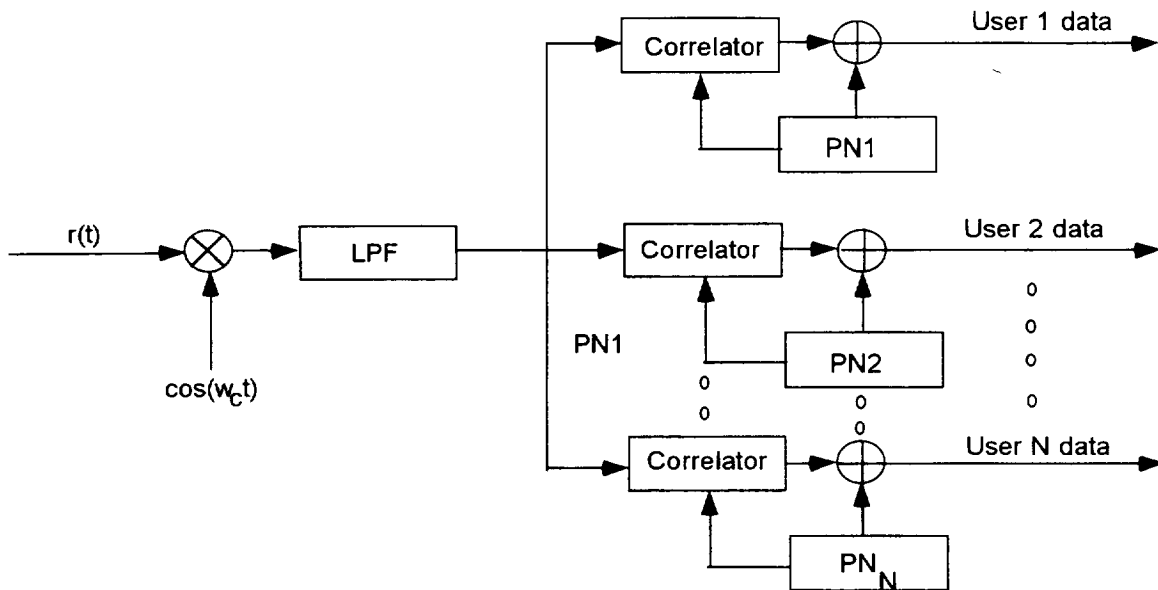

Figure 1.4 CDMA Receiver Model

CHAPTER 2: OPERATIONAL CHANGES TO ACCOMMODATE DAMA CHANNEL

As was stated earlier, the goal of this new system is to provide a USAT with a truly random access capability to the SN via the MA channel. Therefore the KSA and SSA channels will be unaffected by this new service. In the current system, the USAT ephemeris is known apriori. Therefore, the WSC can take the necessary actions to accommodate service. This includes antenna pointing and prediction of carrier frequency deviations from the nominal value due to Doppler shift. If the DAMA service is to be truly random, the WSC will not have the luxury of knowing these parameters. The following will address the changes proposed to create a DAMA service channel on the MA channel of the SN [3].

2.1 Antenna Modifications

As stated earlier, the TDRS have two basic antenna systems. The first is a gimbaled antenna system used for SA traffic. The WSC, via a forward command and control link, will point the antenna at a particular USAT enabling the USATs signal to be received. The second antenna system is a 30 element phased array antenna system. In this configuration, each one of the 30 elements will receive the signal and relay their version of the signal to the WSC. Each element's signal is then scaled by a weighting coefficient in the ground station receiver system. Each element is then multiplexed together to form an antenna pattern that is required for reception of the desired user. Because the DAMA service will occur on the MA portion of the system any changes will occur in the MA receiver portion of the system.

Because the system will not have prior knowledge of a request, a method of processing the antenna's elements in the new DAMA receiver has been developed. A single element of the phased array antenna will be used to provide global coverage of the Earth. This element will receive the DAMA requests and relay these to the WSGT. This is done in the DAMA receiver at the ground station by setting the element weighting

coefficients of all the elements to zero except for one element. This one element will have a coefficient of one and will therefore represent only global coverage. This of course will affect the gain of the system. Evaluation of this type of implementation is contained in a separate technical report [1]. The advantage of using this single element is really threefold. One, it leaves the remaining MA system intact. Two, it provides global coverage and can receive requests from any satellite. And three, it requires no antenna pointing, therefore the WSGT needs no prior knowledge of a request.

There is one important implication of this change. In normal operation, the WSC will predict the Doppler shift created by the relative motion of the USAT and the TDRS when transmission occurs. However, with the use of a single element and with no prior knowledge of a request, the Doppler shift can not be predicted. Analysis has shown [5] that the maximum Doppler offset that can occur with this single element is $\pm 63\text{KHz}$. A method for detecting a DAMA user and predicting the carrier frequency must be developed.

2.2 Change of Data Rate for DAMA requests.

In current operation of the MA channel, the USAT downloads and or uploads data. In the new DAMA service, data will not be transmitted to start with. Instead, a request for service on the SN channels reserved for data transmission is the only information to be sent. Therefore, the transmission rate of the request for service does not need to be as high as that required for normal MA traffic. The data rate will be reduced compared to that of other MA users. This is done for two main reasons. The first is that using a slower chip rate, and therefore an overall lower transmission rate, will increase the link margin because the lower the data rate the lower the losses. This is important because in using a single element some gain will be lost due to the fact that other elements are not being considered. The second reason is to help in the detection of a DAMA user. As the rate of the PN code used to spread the DAMA user decreases compared with that of MA users, the signal will become visible in the frequency spectrum. This is shown in Figure 2.1. The DAMA user is at one half the data rate of the MA user and at a slightly different

carrier frequency. Each user is transmitting with the same amount of power. The shift in carrier frequency was done to make figures easier to see. As illustrated in Figure 2.1 the spectrum of the MA users is spread out compared to that of the DAMA users. In other words, the MA has its power spread out over more frequency while the DAMA users has its power contained over a smaller amount of frequencies. This implies that the power spectral density (PSD) of the DAMA signal will be noticeably higher than the (PSD) of the MA user. This is to illustrate the effect of slowing the chip rate. In reality MA users can have a $\pm 2\text{dB}$ variation due to space loss variation over the orbit.

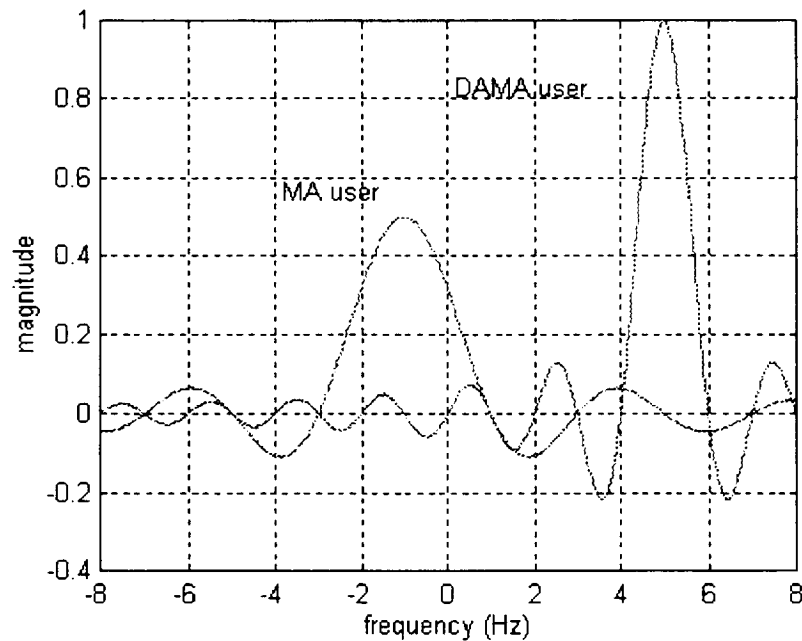

Figure 2.1 Signals

2.3 PN code used for DAMA user

A new PN code will need to be assigned to the DAMA service. The rate of PN code used for DAMA signals will be slowed compared to other MA PN codes. This will be done for the same reason the data rate is slowed, to help facilitate the detection of a DAMA user in the spectrum.

2.4 Satellite Operation with DAMA Service

In this system, a method of servicing all satellites with equal accessibility is desired. Because this is not a scheduled service and the reception is on a first-come/first-serve basis, reception of the transmission is not guaranteed. It is obvious that a USAT requesting a DAMA service might have to attempt multiple times before the request is received. A method for controlling the number of requests will be needed. Once a USAT requests service, it will wait some time (τ) for a response from the SN with either scheduling information or rejection of request. The value of τ will be based on the average time that it takes a request to be serviced. If a USAT does not get a response after τ minutes, it will assume that the request was not received and will attempt the request again. This process will continue until a response is received from the SN or the USATs on board control system stops transmitting the request. This illustrates the importance of having a forward response from the SN even if service is denied.

2.5 Design of a DAMA receiver and processing of DAMA requests.

The changes discussed above will affect the USAT's and WSC receivers. However, there is presently no receiver at the WSC to receive the DAMA requests. The new receiver will have to be able to detect the presence of a DAMA user, determine its carrier frequency, and then using this information receive, demodulate and de-spread the signal. This will result in the true content of the message, that is the actual data request. Because this a new system, there is no known strategy for handling these request once a DAMA request is made. These will be discussed in detail in the following chapters.

CHAPTER 3: DAMA RECEIVER DESIGN

With the advent of changes required to create a DAMA service a new receiver concept has been developed. The new DAMA receiver consists of three parts as shown in Figure 3.1. These stages and their purposes are developed in detail below.

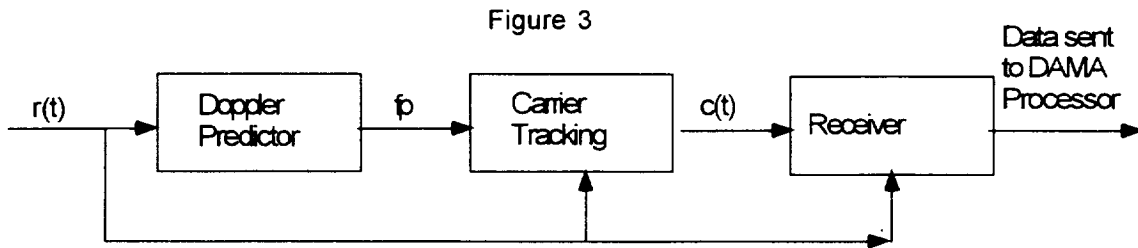

Figure 3.1 DAMA Processing

3.1 Doppler Predictor

Because of the large Doppler Shift that can occur when a USAT requests service and because the request occurs randomly, a method for determining the presence of a DAMA user and the carrier frequency of that user is vital in receiving the DAMA request. As discussed in Chapter 2, the transmission rate of the DAMA user will be reduced compared to other MA users. The DAMA user, as discussed earlier, can be detected in the spectrum. An innovative application of the Fast Fourier Transform (FFT) is used to locate a prospective DAMA user. When the Doppler predictor determines that a DAMA user is present, it will determine the carrier frequency of the user and pass this information to the carrier tracking loop [4].

3.2 Carrier Tracking

The purpose of the carrier tracking loop is to match the phase of the incoming signal to the phase of the local oscillator used to demodulate the signal. This is where

knowledge of the DAMA user's carrier frequency is important. Knowledge of the carrier frequency is fundamental in demodulating any signal. The basic configuration of this system is shown below in Figure 3.2 [6].

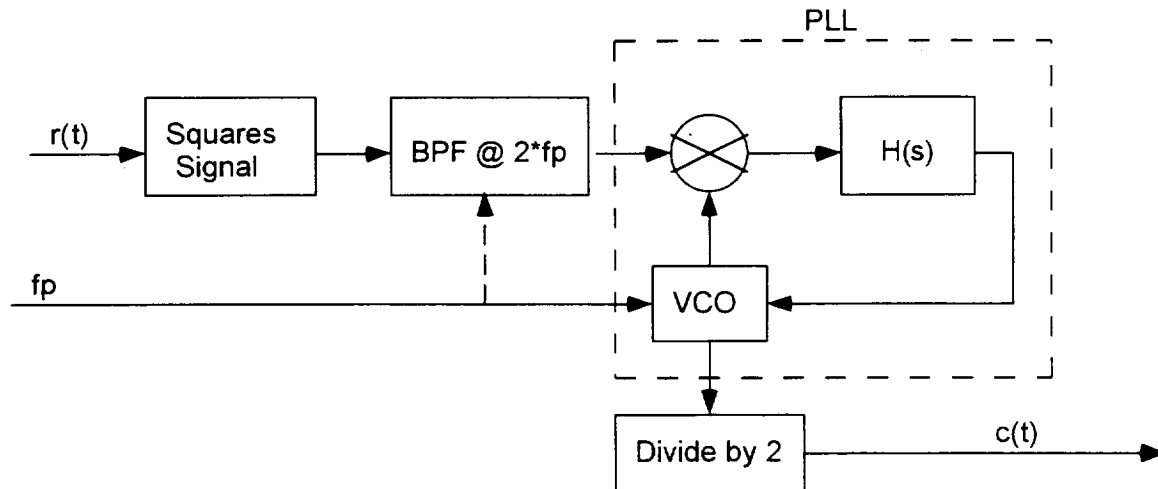

Figure 3.2 Carrier & Phase Tracking

As can be seen above, the primary component in the carrier tracking consists of a phase lock loop. This type of carrier tracking loop is standard for most systems. In the PLL design, the VCO will have a nominal operating frequency. This is the frequency the VCO operates at with a zero input. A zero input implies that the phase of the incoming signal and the phase of the VCO are the same. In this system, the Doppler Predictor will send the VCO the carrier frequency of the prospective DAMA user. In Figure 3.2 this value is represented as f_p . This value will become the nominal operating frequency of the VCO thereby allowing phase synchronization of the incoming signal and the VCO. The function of the squaring signal is to remove the modulation from the incoming waveform. The divide by two is done to remove the effects of the squaring function. That is if carrier input is 10Hz and is squared the value is moved to a frequency of 20Hz and 0Hz. After filtering the value is at 20Hz, therefore the value has to be divided by two to represent the carrier of 10Hz. It is important to note that the VCO and BPF will need to

be programmable, thus allowing for the characteristics to change based on the various input values.

3.3 Receiver

The receiver function is to retrieve the prospective DAMA request that is spread at passband and bring the signal to baseband and then de-spread the signal. Once this has been done, the message can be processed. The receiver will use information obtained from the carrier tracking loop to perform this processing. There are certain steps taken to receive these requests. These will be broken down further into various parts to help detail each function's contribution to the process. The basic configuration is illustrated in Figure 3.3.

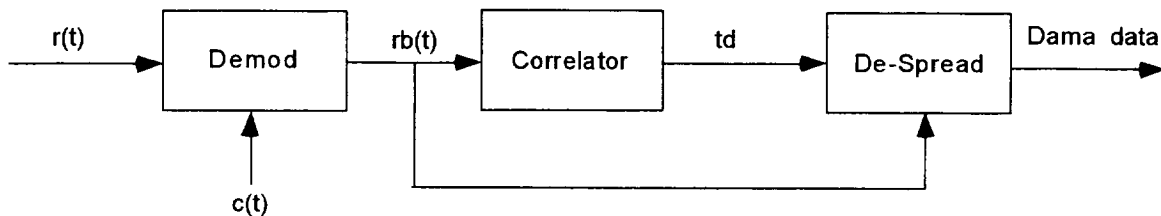

Figure 3.3 DAMA Receiver

In Figure 3.3 $r(t)$ is the received DAMA signal, $rb(t)$ is the received signal at baseband, $c(t)$ is the carrier and phase information obtained by the carrier tracking loop, and td is timing information from the correlator. The use of these values will be explained below.

3.3.1 Demodulator

The purpose of a demodulator is to extract the modulation from a data bearing signal. As discussed earlier the method of transmission on the MA channel is BPSK. Therefore, the receiver will be designed to demodulate BPSK signals. Figure 3.4 illustrates the demodulator configuration that will be used to bring the received MA signal back to baseband.

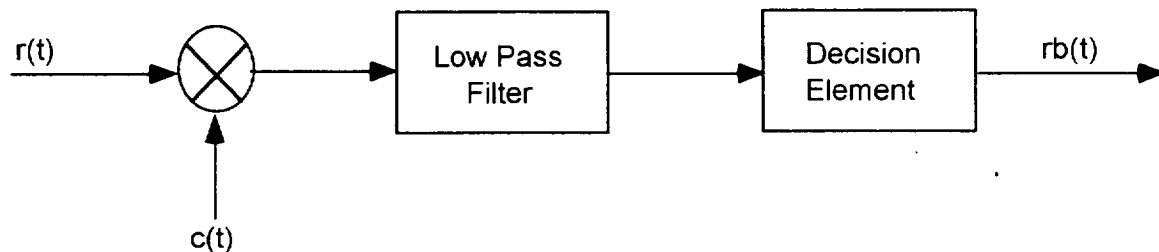

Figure 3.4 DAMA Demodulator

The mixer input value $c(t)$ will be received from the carrier tracking portion and will contain the appropriate frequency and phase to mix with the MA signal $r(t)$. The signal will then be low pass filtered (LPF) to remove the out of band components created by the mixing process. The exact parameters of the LPF are important in this case. The standard MA receiver will place the cutoff frequency at approximately the PN rate of a MA user. Because the PN DAMA rate will be slower for reasons mentioned previously, the DAMA receiver will set its cutoff frequency to be that of the PN DAMA. The effects of this will be discussed in the next chapter.

3.3.2 Correlation to DAMA PN code

As was discussed in the section on CDMA, the correlation of the incoming spread signal at baseband $rb(t)$ with the PN code dedicated to DAMA users is the first step to de-spreading the signal. The basic configuration of a correlator is shown in Figure 3.5 below [4].

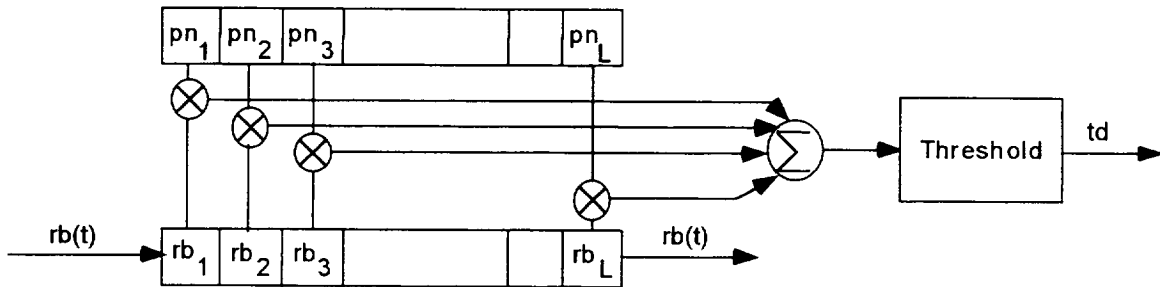

Figure 3.5 Correlator

The received baseband data $rb(t)$ will be passed through the circuit above. The PN DAMA code pn will be stored in the top register. As the data moves through the lower register, a bit by bit comparison will be performed on the two registers. This value will then be summed and passed to a threshold device. When the value of correlation becomes greater than some threshold, the two registers will be highly correlated and a signal tb will be passed to the de-spreader. The signal td will basically be a ready signal enabling the despreader to start operation. In general the length of the correlator is the length of the pn code L , this will be discussed later in sec 5.1.

3.3.3 De-spreading DAMA signal

De-spreading the data is simple once detection has been accomplished. The correlator output (td) will indicate when correlation to the DAMA PN code has occurred. This signal will then be used to inform the de-spreader of the correct timing phase to start the process. This is shown below in Figure 3.7.

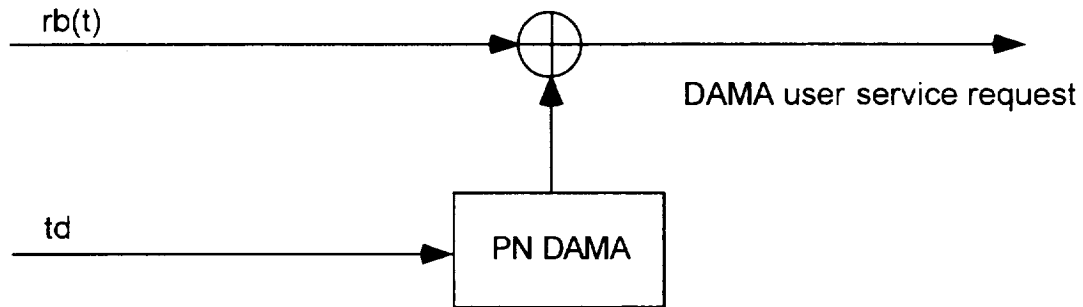

Figure 3.7 De-Spreader

The result of this process is a DAMA service request. Once this is received certain steps must be taken, this will be discussed in chapter 5.

CHAPTER 4: SIMULATIONS

4.1 Methodology

In order to predict the performance and verify concepts of the receiver design, an evaluation is needed. In this project, the software package Signal Processing Workstation (SPW) was used to simulate the receiver. This is a block based program allowing the user to connect various blocks to simulate a system. The frequency and time characteristics at any point in the simulation can be probed to visually inspect the simulation. The basic method used was to design each of the sub-components separately testing concept at each point. These sub-components are generally a spreading function, a modulator section, a demodulation section and a de-spreading section. The overall system was then combined piece by piece in the order listed above. The resulting system was then simulated with various parameters.

4.1 Basic Configuration of Simulation Used:

The system model consisted of two sets of random data that represent two users. Each set of data is then modulo 2 added to a PN code. This result is then modulated onto a carrier frequency. These results are then summed together to simulate a common channel and transmitted. The received signal is demodulated and then passed through a LPF and finally de-spread with one of the PN codes. The simulations below evaluate the system model with various values of carrier frequency, data rates, and PN code rates for each user. This model can also be used to simulate multiple users by simply adding more users and summing these all onto the common channel for transmission.

In simulating these various situations, the actual numbers were scaled appropriately, therefore making simulation possible within a reasonable time frame. For example, the nominal DAMA carrier frequency for simulations is set at 4Hz, where the actual frequency is 2.2GHz. The amount of offset due to Doppler is $\pm 63\text{KHz}$. This represents a 0.003% deviation from nominal, therefore in simulations the 4Hz signal will

be varied by 0.003% to simulate the effects of the Doppler shift. These calculations performed below.

The Doppler shift can cause the carrier to deviate by $\pm 63\text{KHz}$ [5]. The deviation from the nominal value is calculated as

$$\frac{(2.2G \pm 67K)}{2.2G} * 100 = 0.003 \%$$

To simulate the same possible effects of Doppler shift the 4Hz carrier must deviate by $\pm 0.003 \%$. The deviation x for simulation is calculated as

$$\frac{x - 4}{4} * 100 = 0.003$$

$$x = 4.0012$$

Therefore in simulation the carrier frequency of a MA user can vary by $4\text{Hz} \pm 0.0012 \text{ Hz}$.

4.2 Simulations

The simulations as shown in the following figures below will illustrate the input data of the DAMA user as well as the output of the DAMA receiver. The top figure represents the input request by the DAMA user. The bottom figure represents the output of the DAMA receiver. When the receiver is working the output (bottom) will be a delayed version of the input (top). This illustrates the ability to receive a DAMA user under various conditions that will be experienced in the real system. The parameters used for the various simulations are contained in tables below. They are then followed by a description and finally the simulation results. Figure 4.1.1 and 4.1.2 on the following pages illustrate the basic model simulated.

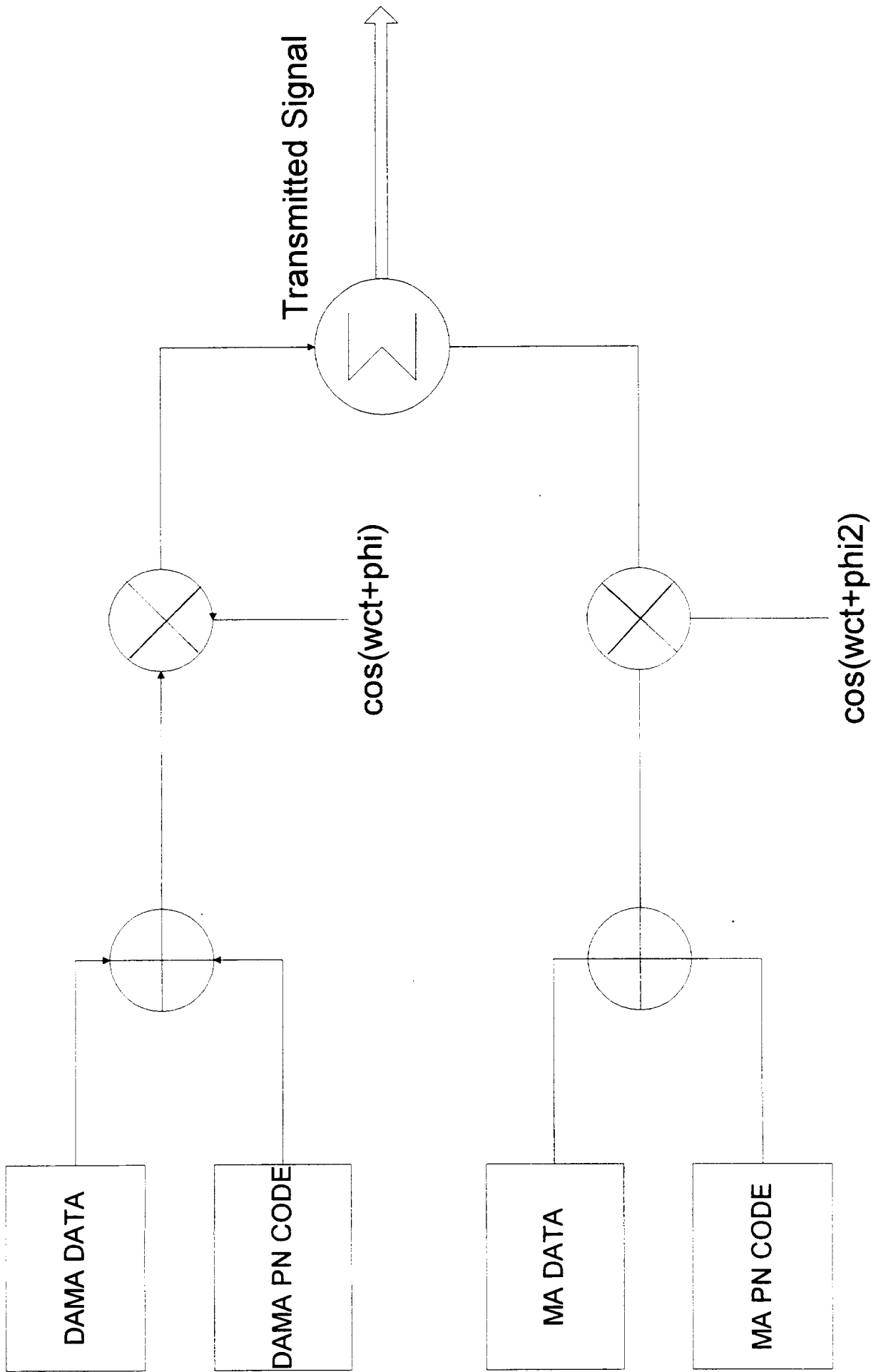
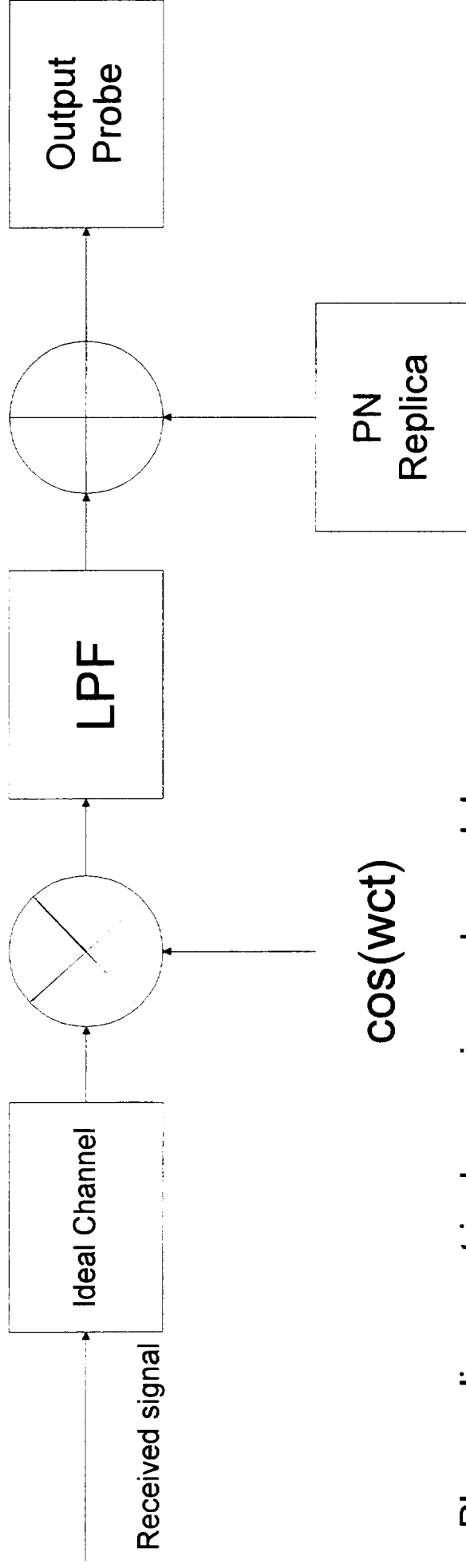

Figure 4.1.1

modolo 2



Phase alignment is done using a phase delay meter in SPW. This allows the user to set the appropriate phase of the DAMA user at the receiver to model a PLL

PN (DAMA) correlation is done by using a system delay meter. This allows the user to set the delay thus modeling a correlator

Figure 4.1.2

Table 4.1 Simulation Parameters

Sim	Data DAMA	Data MA1	PN DAMA	PN MA1	Carr. DAMA	Carr. MA1
1	1bps	1bps	2bps	2bps	4.0Hz	4.00012
2	1bps	1bps	2bps	2bps	4.0Hz	4.00006
3	1bps	1bps	2bps	2bps	4.0Hz	4.00001
4	1bps	1bps	2bps	2bps	4.0Hz	4.0
5	1bps	1bps	2bps	2bps	4.0Hz	4.0

Simulations 1-4 contain two users, one represents the DAMA user and the other a MA user. The data rates as well as the chip rates of both users are the same. The PN codes are different for each user. The carrier frequency of the MA user varies from the maximum level of Doppler shift to the nominal value of carrier frequency. Simulation 5 contains two users with the same PN code. This illustrates the ability to receive the first DAMA request while rejecting a second request that comes in delayed by a small fraction of time.

Figure 4.2.1 Simulation 1

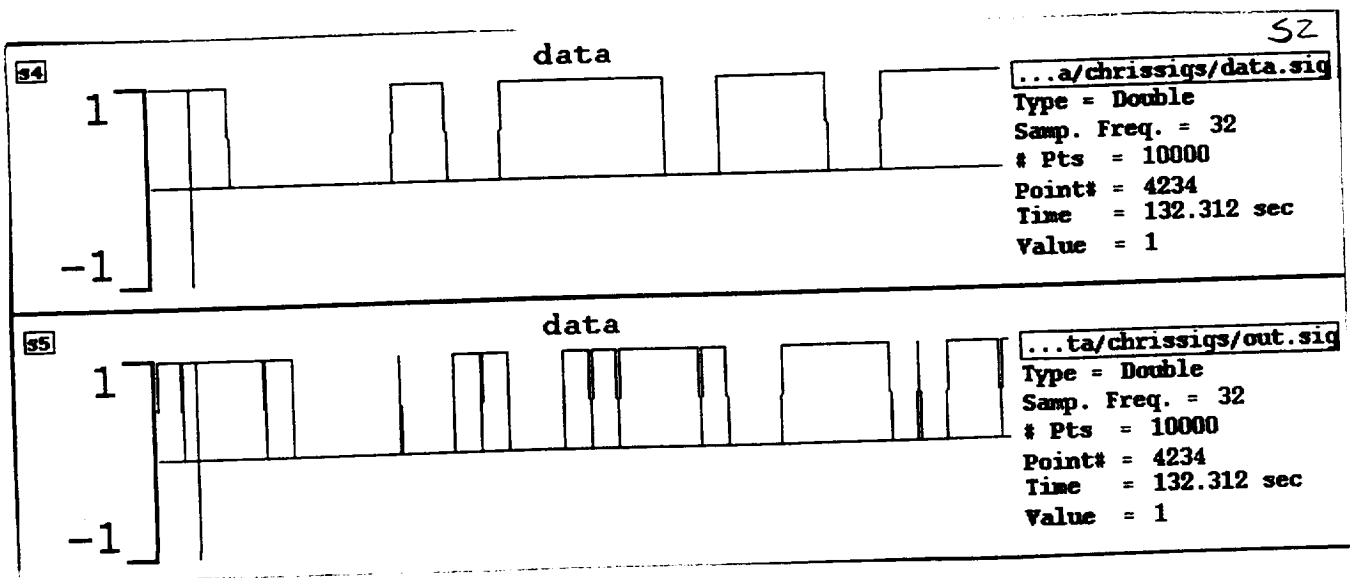

Figure 4.2.2 Simulation 2

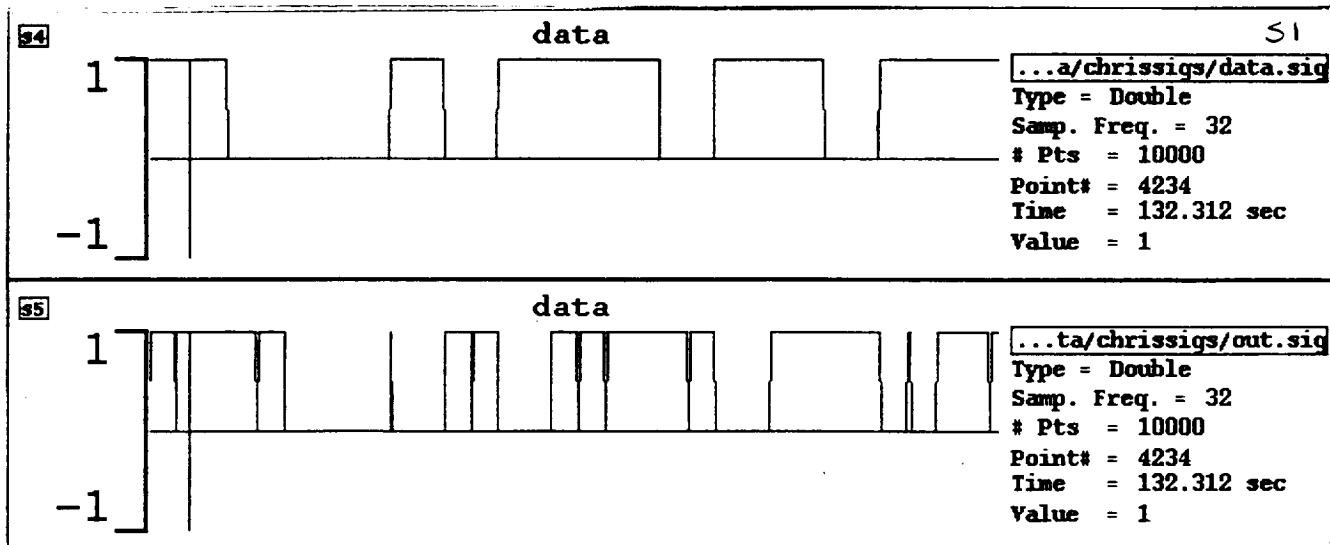
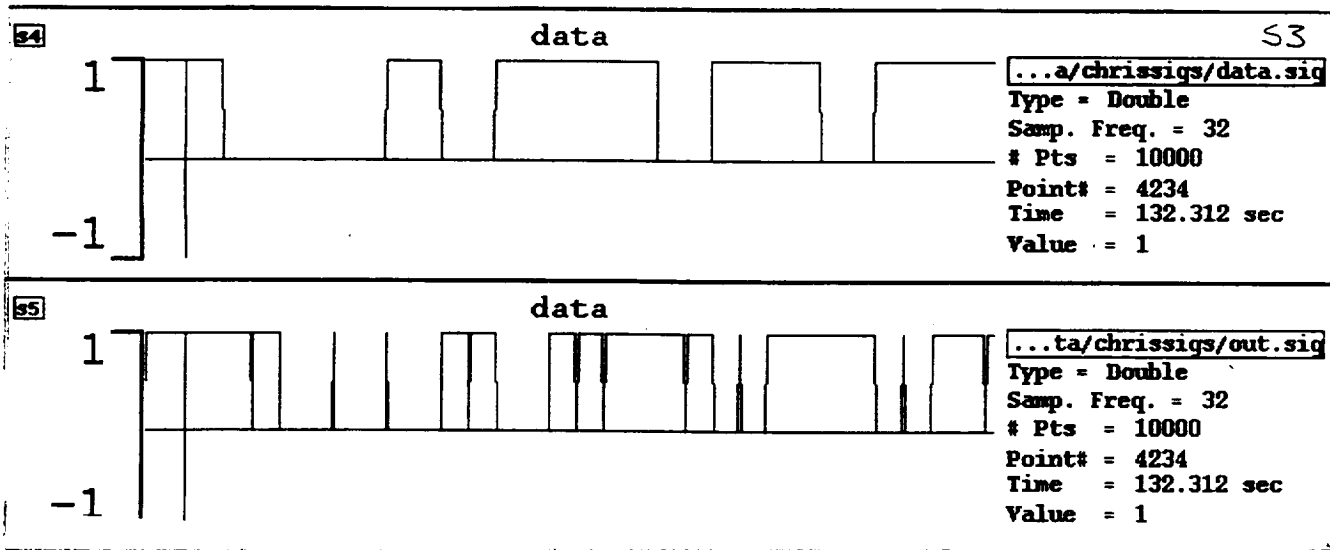

Figure 4.2.3 Simulation 3



Simulation 4

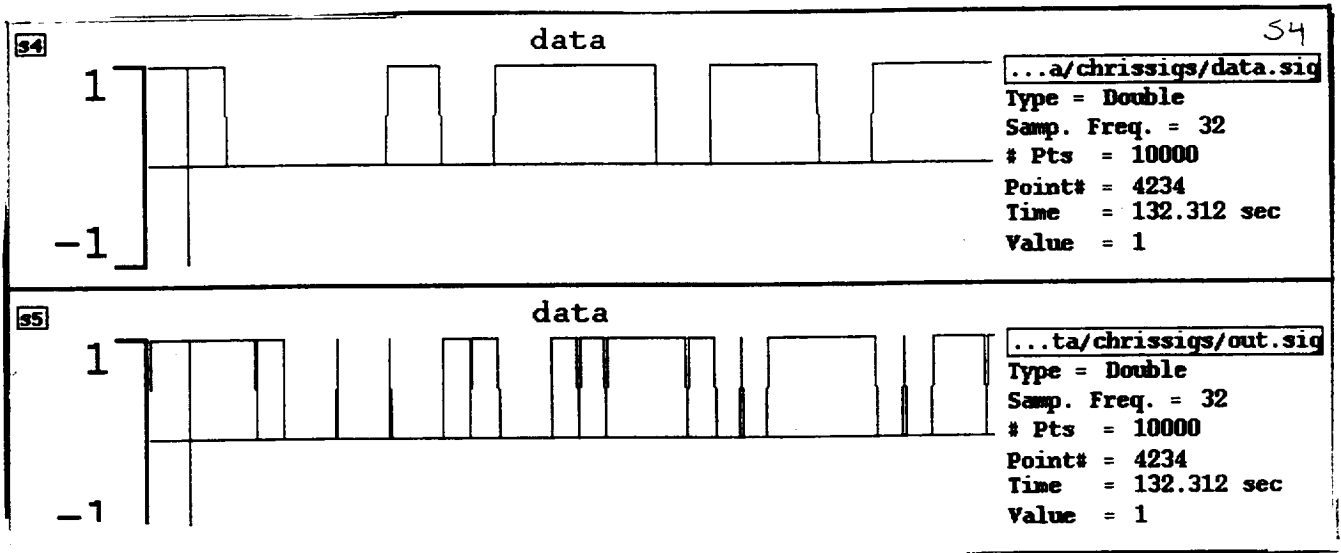

Figure 4.2.5 Simulation 5

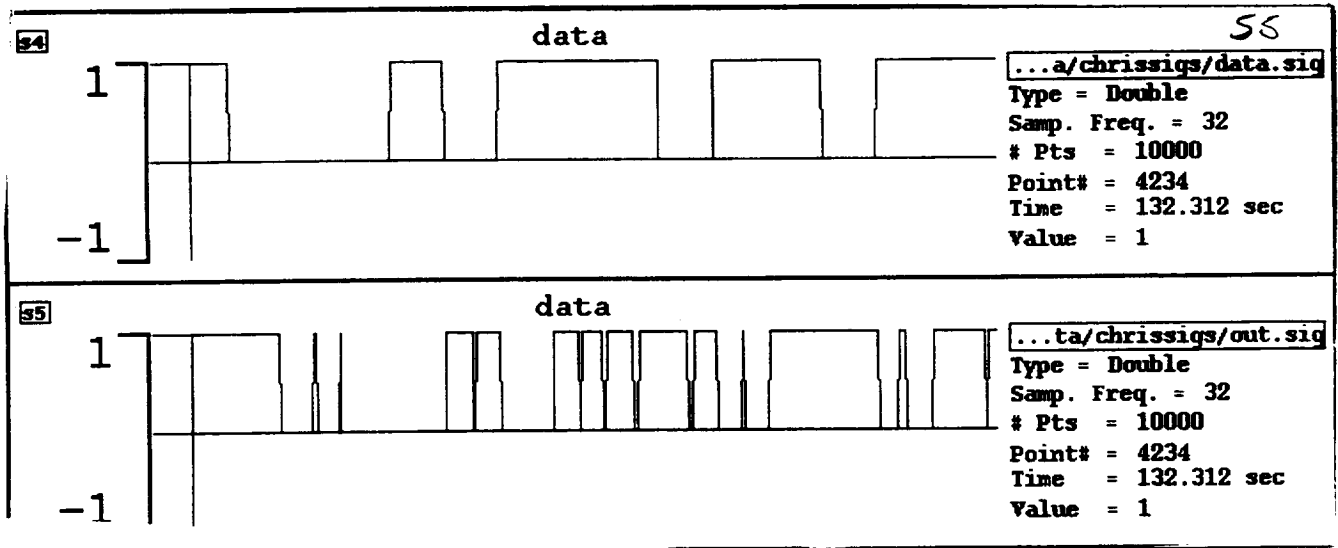

Table 4.2 Simulation Parameters

Sim	Data DAMA	Data MA1	PN DAMA	PN MA1	Carr. DAMA	Carr. MA1
6	0.25bps	1bps	0.5bps	2bps	4.0Hz	4.00012
7	0.25bps	1bps	0.5bps	2bps	4.0Hz	4.00006
8	0.25bps	1bps	0.5bps	2bps	4.0Hz	4.0

Simulations 6-8 contain two users. In this case, the DAMA user has a data and chip rate one fourth of the MA user. Again, the values of carrier are varied across the possible values of carrier frequency.

Figure 4.2.6 Simulation 6

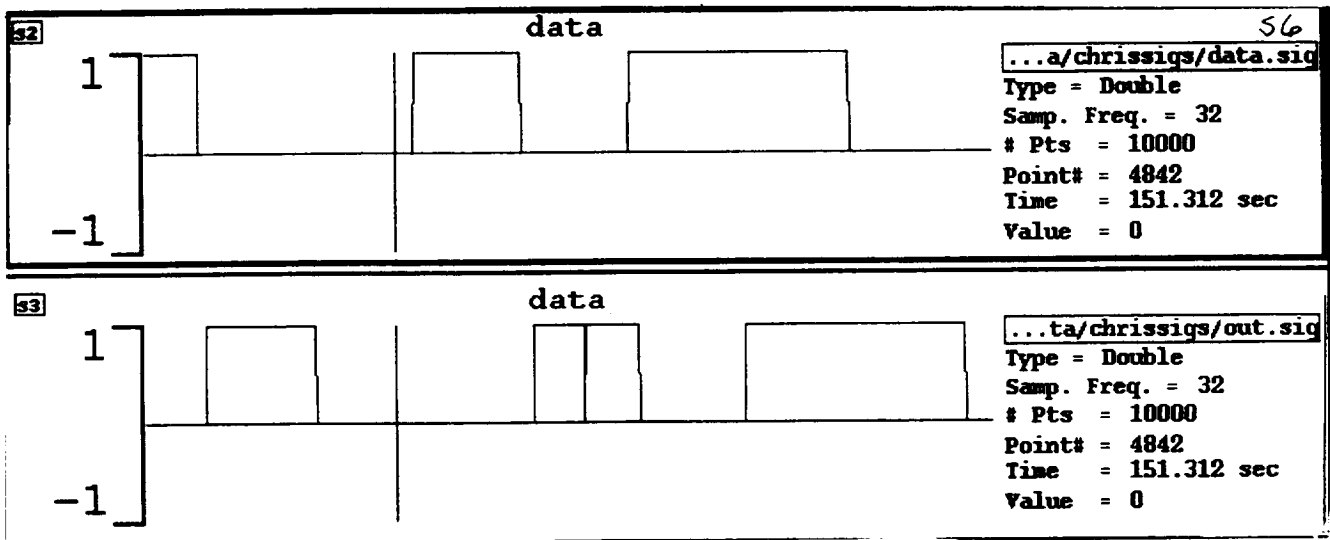

Figure 4.2.7 Simulation 7

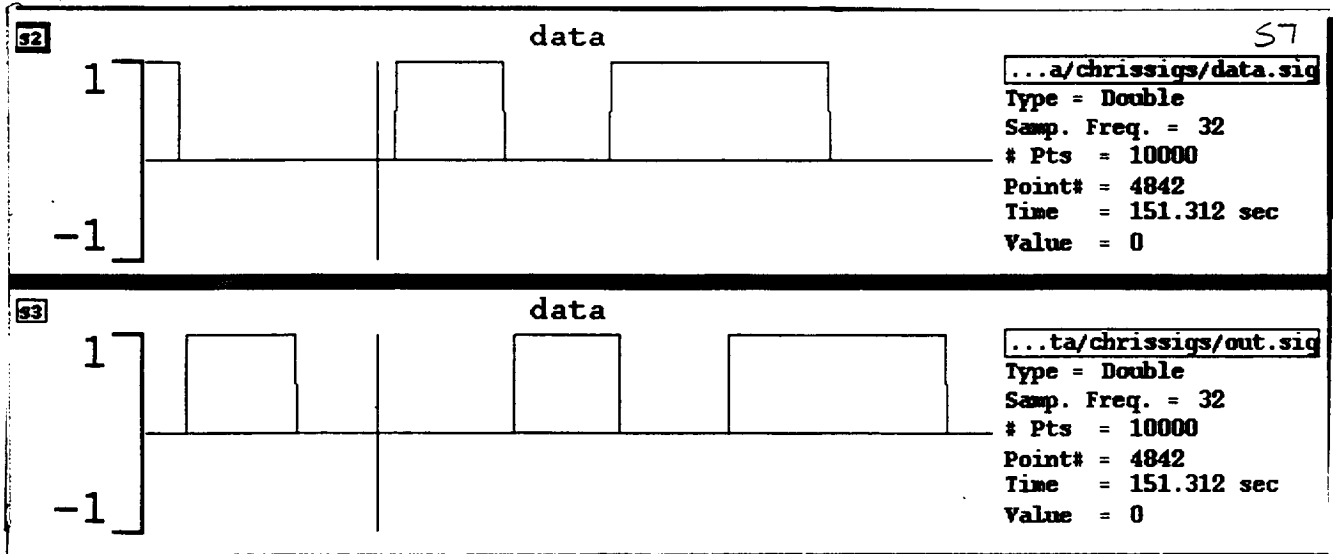

Figure 4.2.8 Simulation 8

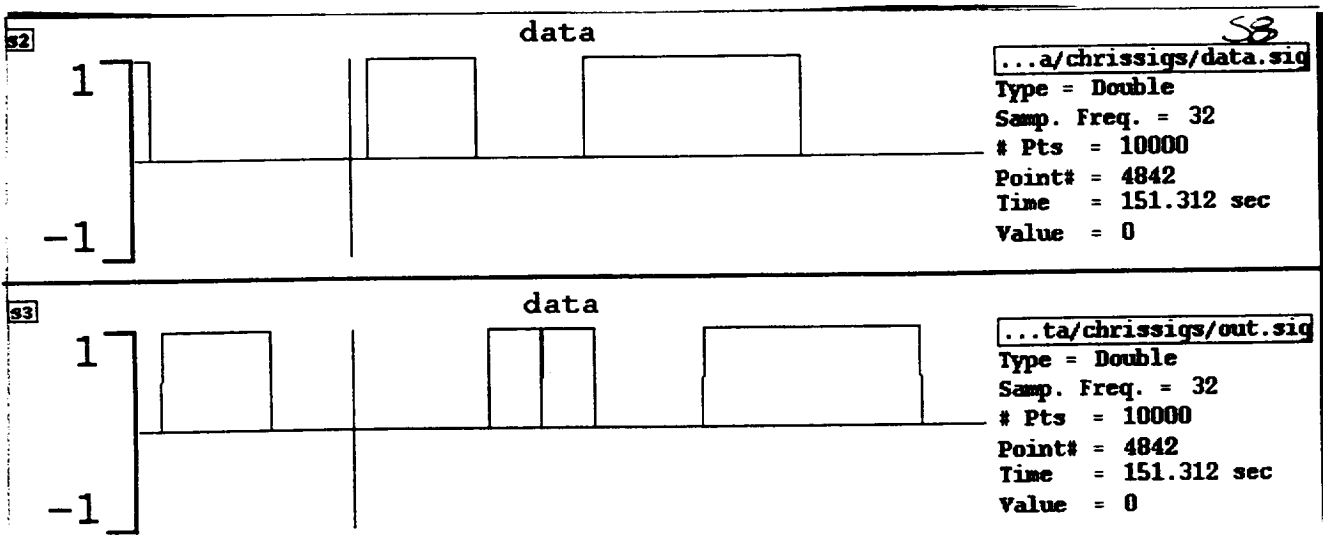

Table 4.3 Simulation Parameters

Sim	Data	Data	PN	PN	Carr.	Carr.
	DAMA	MA1	DAMA	MA1	DAMA	MA1
9	.0625bps	1bps	.125bps	2bps	4.0Hz	4.00012
10	.0625bps	1bps	.125bps	2bps	4.0Hz	4.00001
11	.0625bps	1bps	.125bps	2bps	4.0Hz	4.0

In simulations 9-11 the number of users is still two. In these simulations the chip and data rates of the DAMA user is reduced by one fourth of simulations 6-8, and one sixteenth of the rates of simulations 1-5. The values of carrier frequency are again varied over the possible range.

Figure 4.2.9 Simulation 9

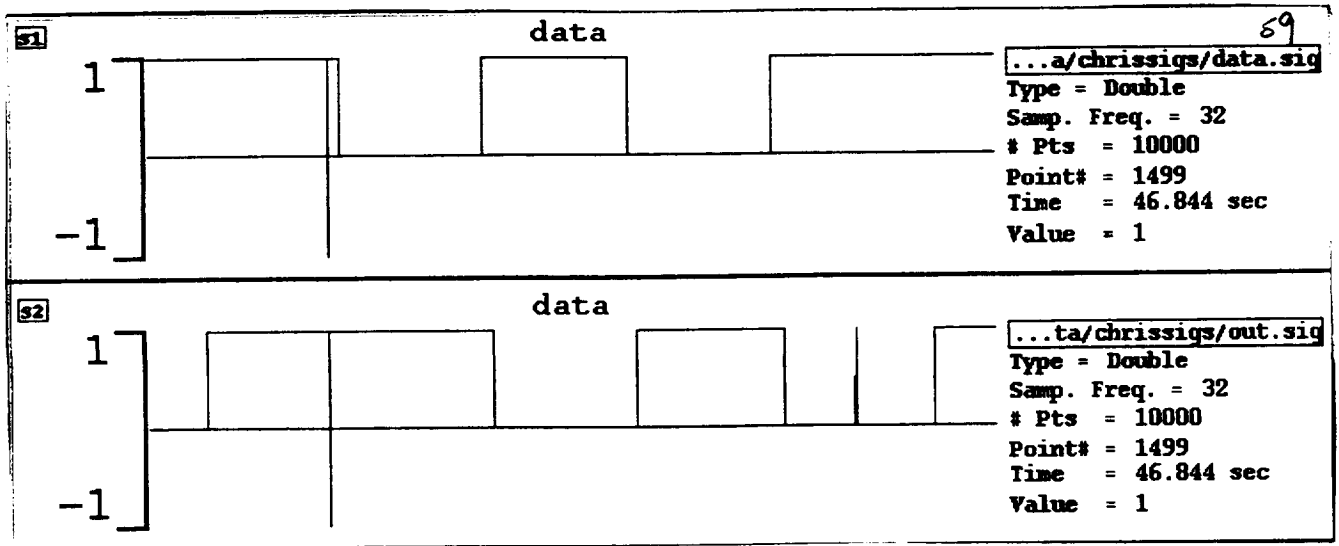

Figure 4.2.10 Simulation 10

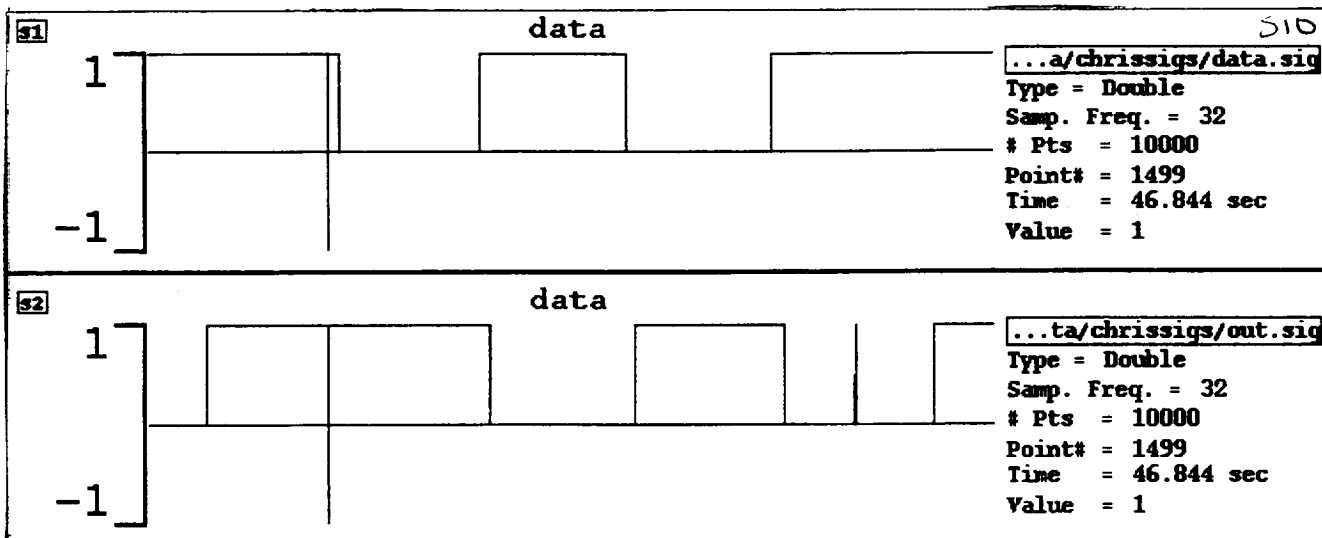

Figure 4.2.11 Simulation 11

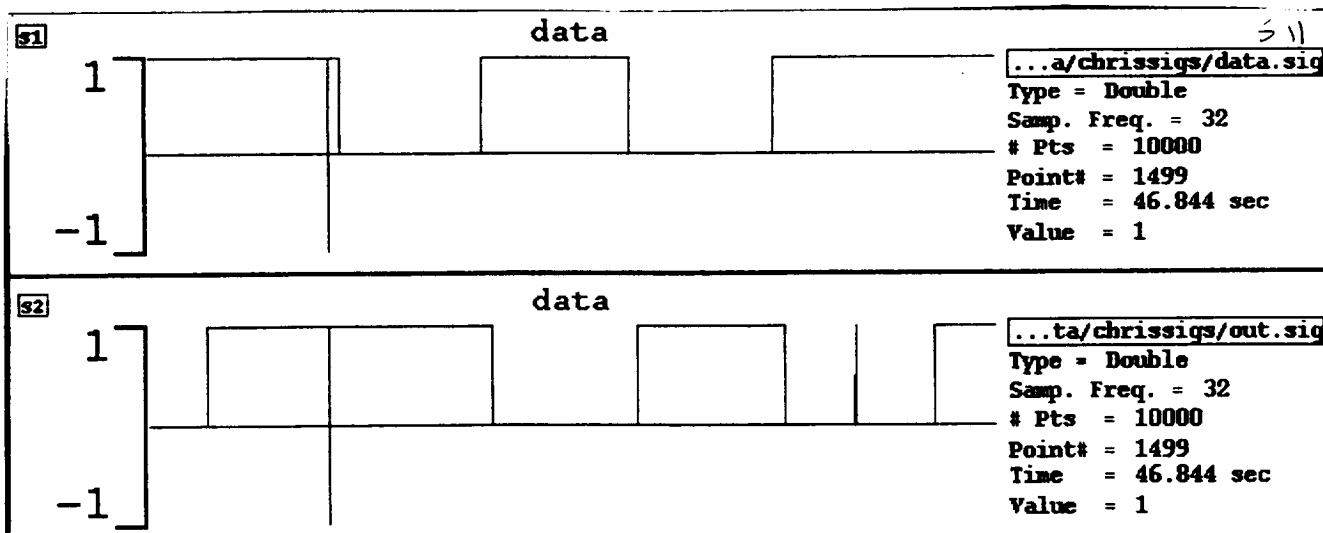

Table 4.4 Simulation Parameters

Sim	Data DAMA	Data MA1	Data MA1	PN DAMA	PN MA1	PN MA2	Carr. DAMA	Carr. MA1	Carr. MA2
12	1bps	1bps	1bps	2bps	2bps	2bps	4.0Hz	4.00006	4.00006
13	1bps	1bps	1bps	2bps	2bps	2bps	4.0Hz	4.00001	4.00012
14	1bps	1bps	1bps	2bps	2bps	2bps	4.0Hz	4.0	4.0

Simulations 12-14 contain three users. One DAMA user and two MA users. The users are all at the same data and chip rates. The values of carrier frequency will be varied about the range of possible values.

Figure 4.2.13 Simulation 12

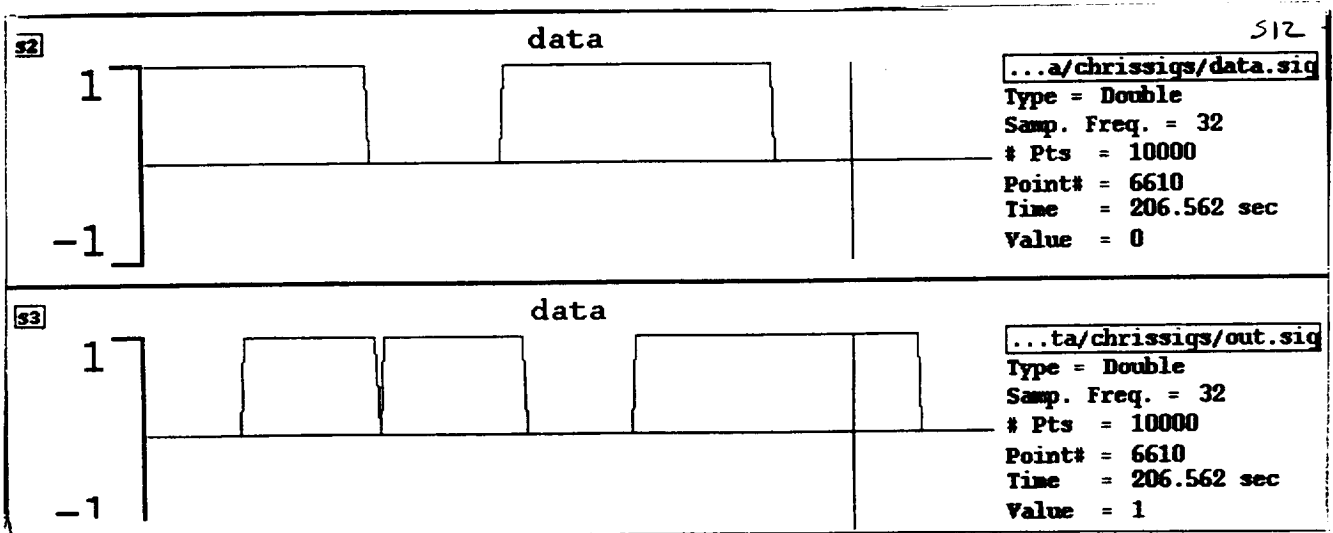

Figure 4.2.13 Simulation 13

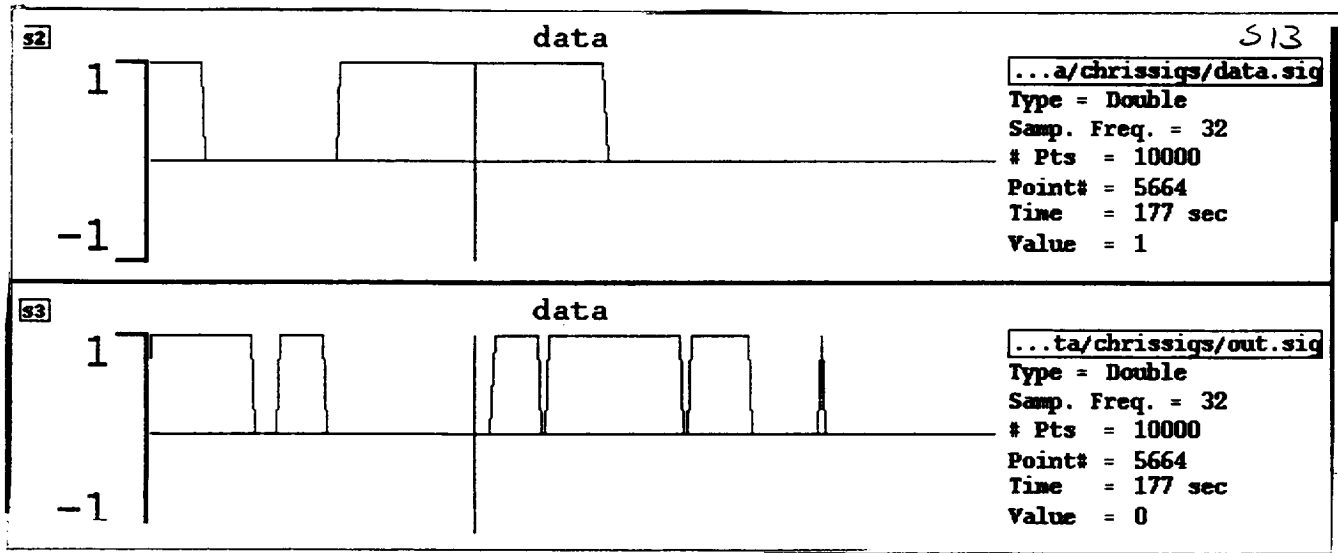

Figure 4.2.14 Simulation 14

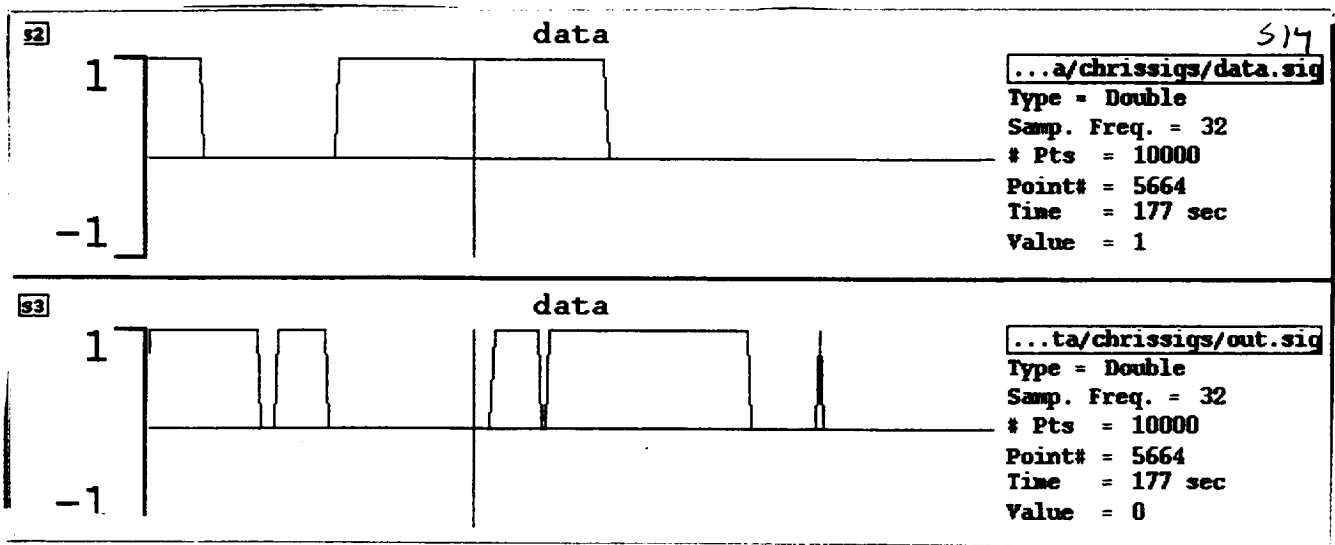

Table 4.5 Simulation Parameters

Sim	Data DAMA	Data MA1	Data MA1	PN DAMA	PN MA1	PN MA2	Carr. DAMA	Carr. MA1	Carr. MA2
15	0.25bps	1bps	1bps	0.5bps	2bps	2bps	4.0Hz	4.00012	4.00006
16	0.25bps	1bps	1bps	0.5bps	2bps	2bps	4.0Hz	4.00001	4.00012
17	0.25bps	1bps	1bps	0.5bps	2bps	2bps	4.0Hz	4.0	4.0

Simulations 15-17 contain three users. The DAMA users chip and data rate is one fourth that of the other two MA users. The carrier frequency are one again varied across the range of values.

Figure 4.2.15 Simulation 15

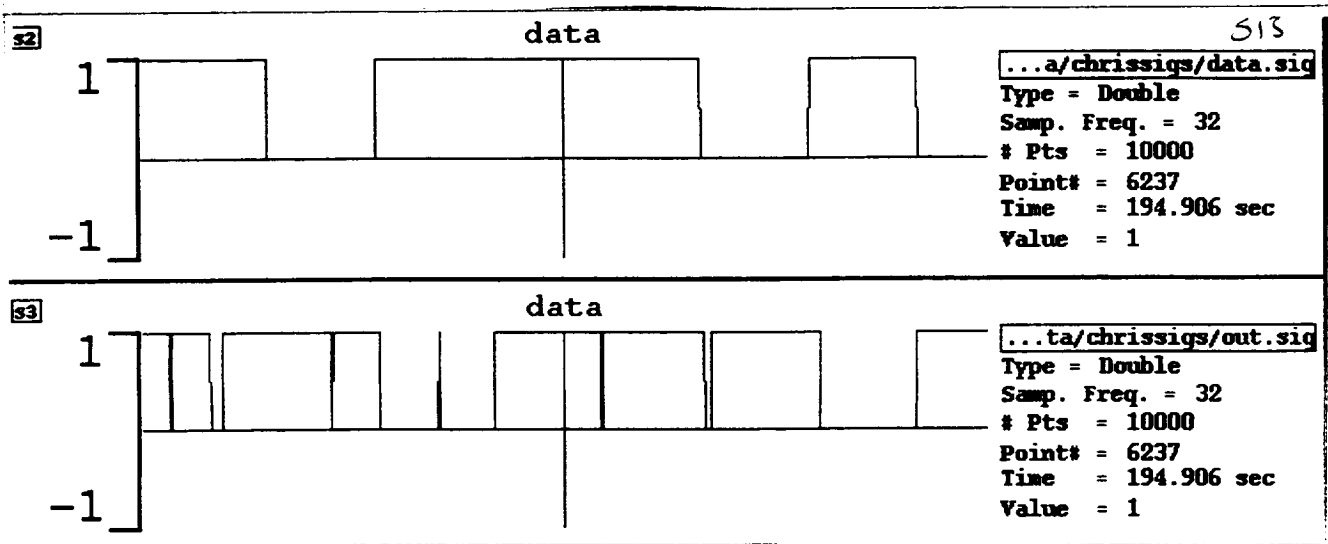

Figure 4.2.16 Simulation 16

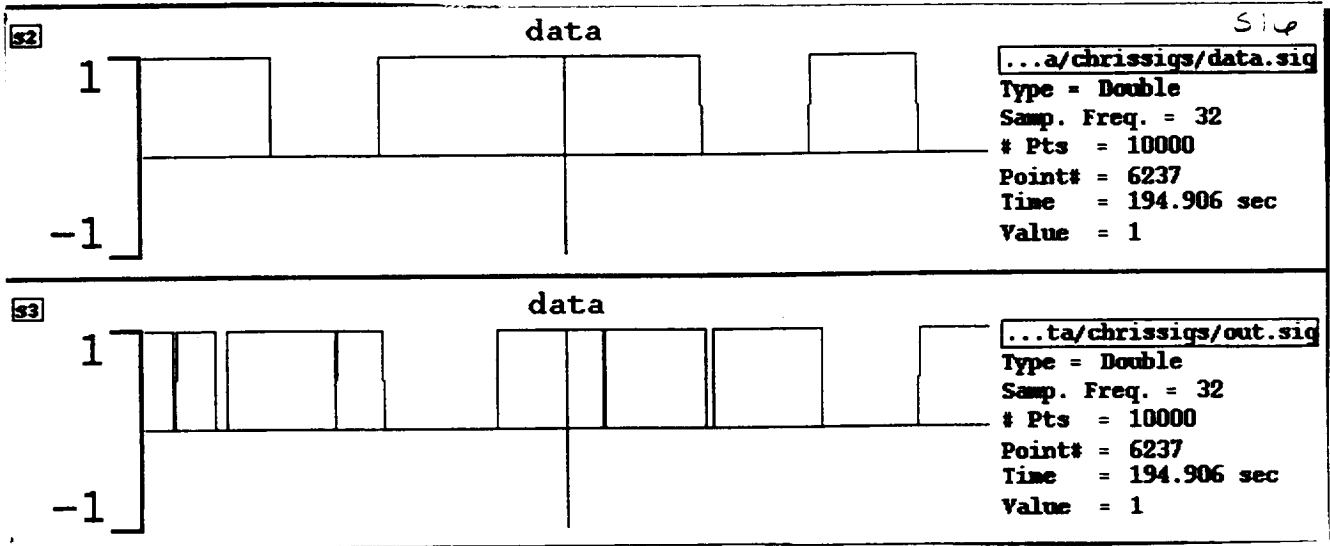

Figure 4.2.17 Simulation 17

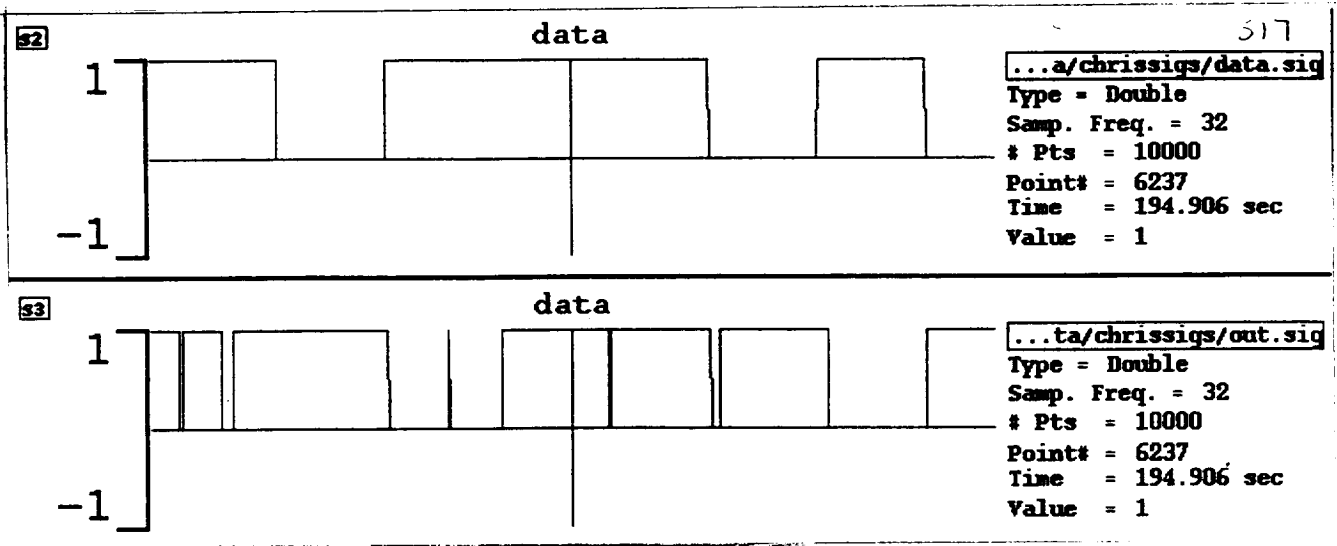

Table 4.6 Simulation Parameters

Sim	Data DAMA	Data MA1	Data MA1	PN DAMA	PN MA1	PN MA2	Carr. DAMA	Carr. MA1	Carr. MA2
18	.0625bps	1bps	1bps	.125bps	2bps	2bps	4.0Hz	4.00012	4.00006
19	.0625bps	1bps	1bps	.125bps	2bps	2bps	4.0Hz	4.00001	4.00012
20	.0625bps	1bps	1bps	.125bps	2bps	2bps	4.0Hz	4.0	4.0

Finally simulations 18-20 contain three users. The chip and data rate of the DAMA user is slowed by one fourth of simulations 15-17 and one sixteenth that of simulations 12-14.

Figure 4.2.18 Simulation 18

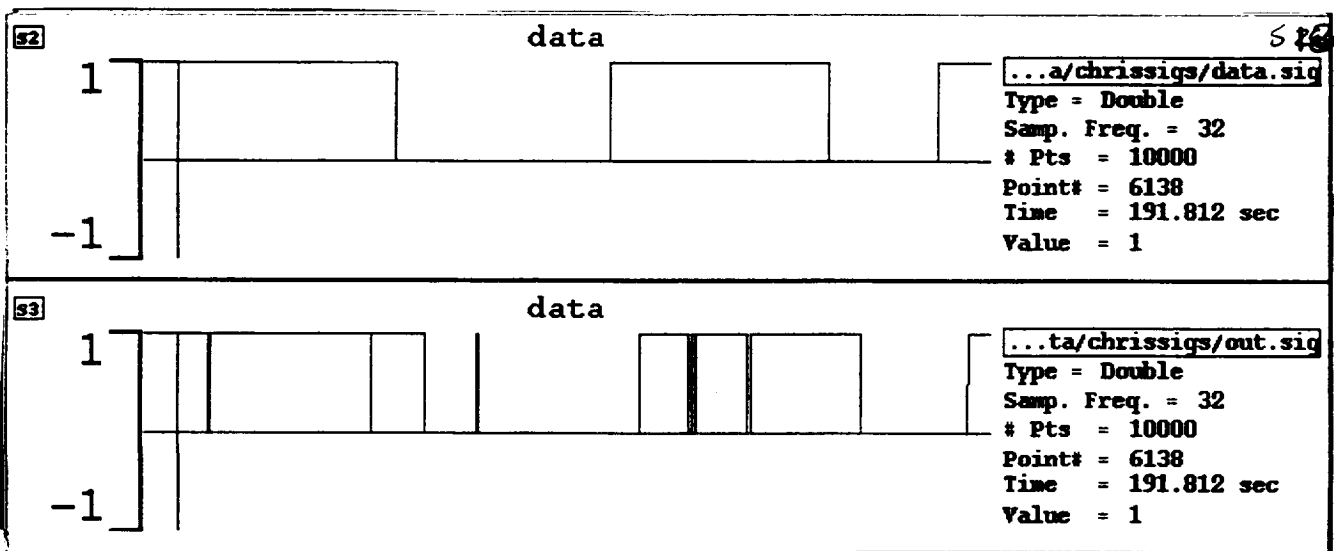

Figure 4.2.19 Simulation 19

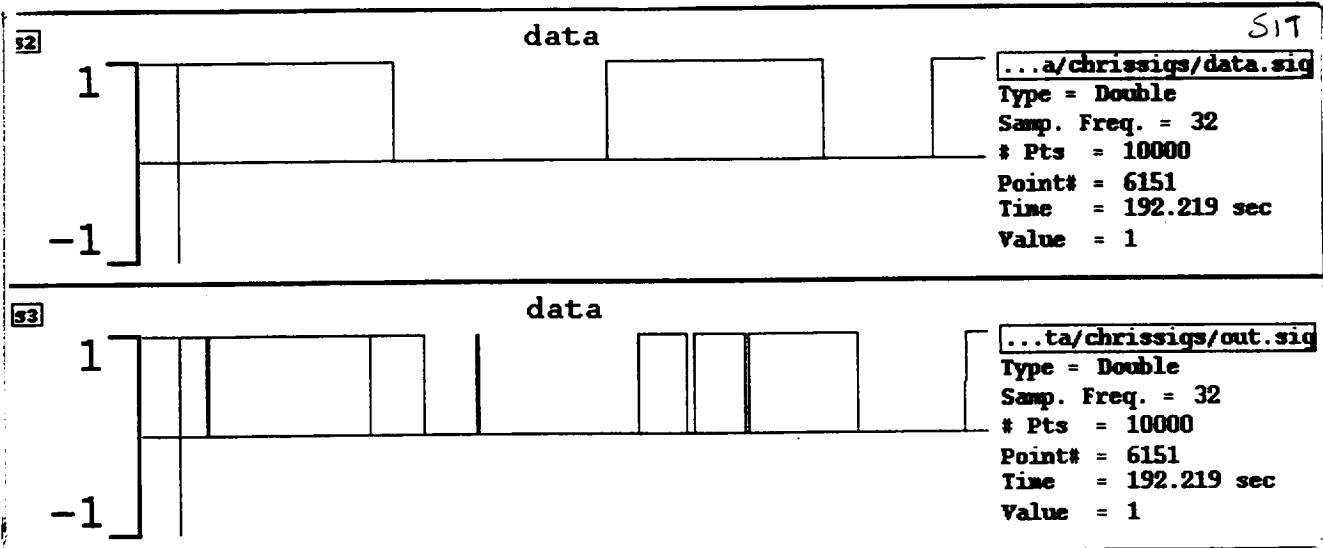
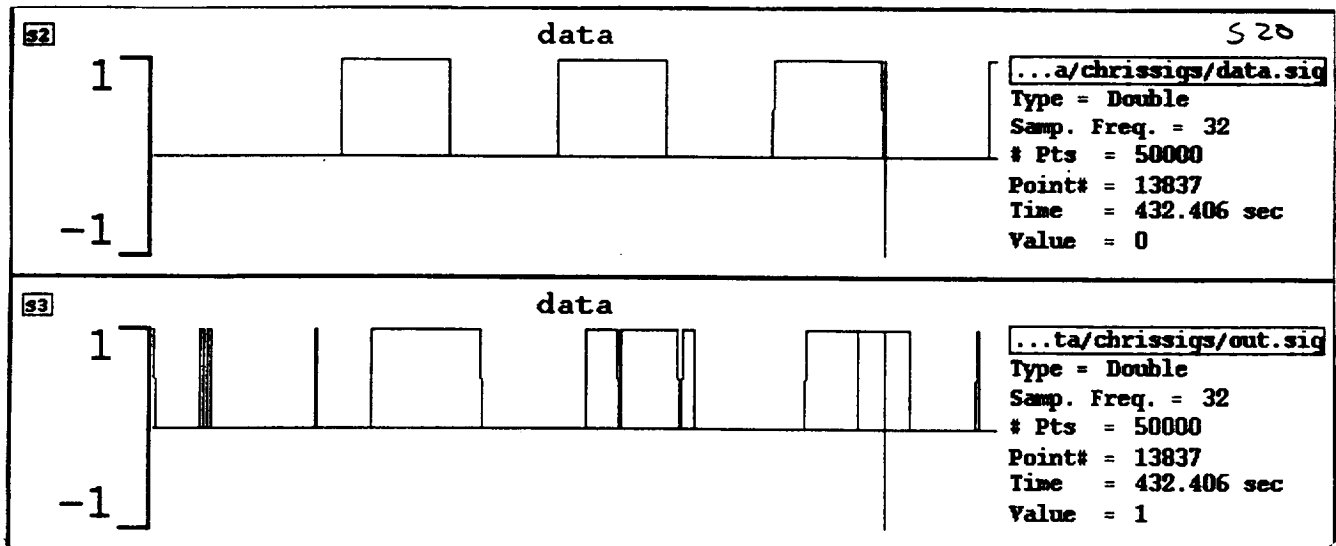

Figure 4.2.20 Simulation 20



4.3 Evaluation of Receiver Performance

In figures 4.2.1-4.2.20 illustrate the input DAMA data to the system and a delayed replica of the DAMA data representing the receiver output. In every simulation the output (bottom) is a noisy time delayed version of the input (top). This reinforces the receivers capability of receiving DAMA requests under the various conditions possible. In comparing the results it is important to note the reason for the transients in the output DAMA request. This is caused by imperfectly matching the timing. This is a function of the software's delay through the system not being an integer number of samples. The delay intruded to match the simulation delay can only be integer.

In evaluating the different simulations it can be seen that when the MA user and the DAMA user are at the same chip rates the reception becomes a little difficult. Whereas when the chip rate of a DAMA user is slowed compared to that of a MA user detection becomes very easy. This is primarily due to the cutoff frequency of the LPF. As discussed above, the cutoff frequency should be approximately the chip rate of the DAMA user. Figure 4.2 illustrates this configuration. This shows the component of interference caused by the MA user or users.

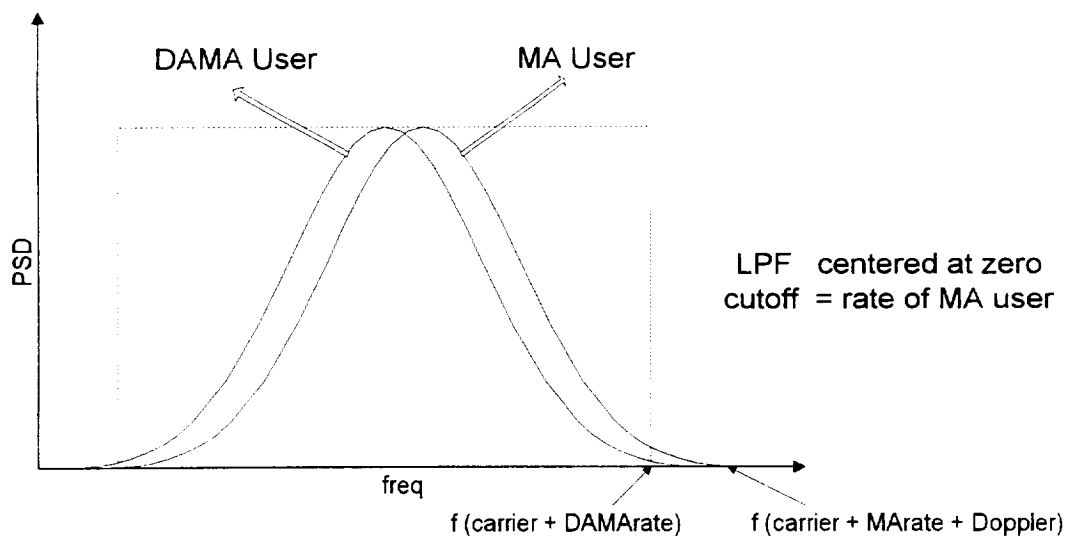

Figure 4.3 (MA = DAMA chip rate)

As the chip rate of the DAMA user is slowed compared to the MA user the value of the cutoff frequency of the LPF becomes proportionally smaller. Therefore the amount of interference by the MA users becomes even smaller. This is illustrated in Figure 4.3 below.

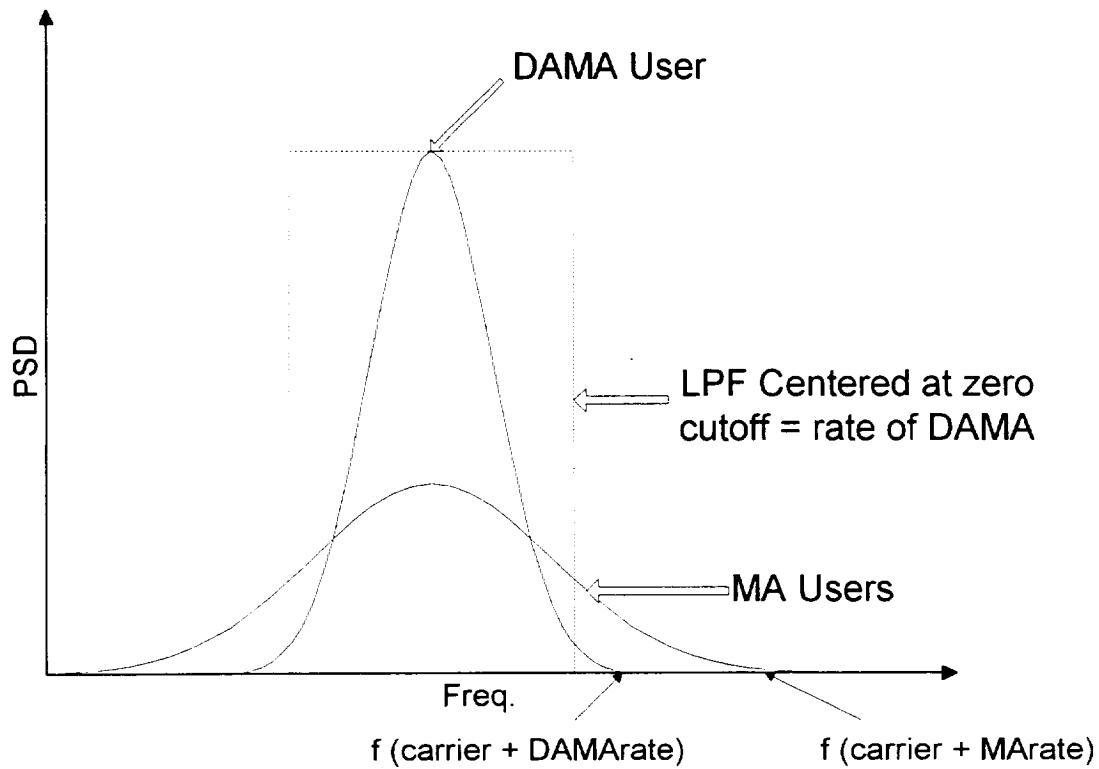

Figure 4.4 (MA = 2* DAMA chip rate)

Finally, if the chip rate of the DAMA user is slowed even more the LPF becomes even narrower and the interference from other MA users becomes even less. This is shown in Figure 4.4.

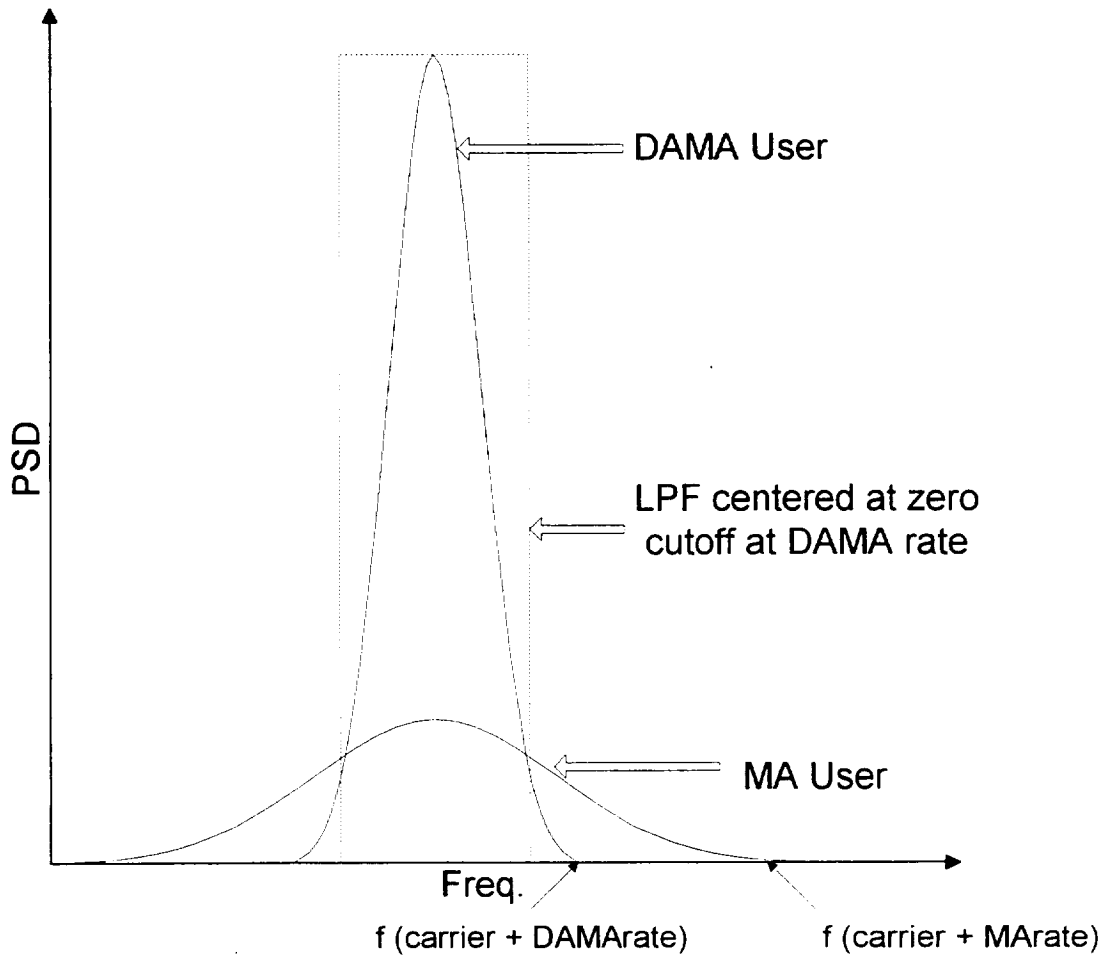

Figure 4.5 (MA = 4* DAMA chip rate)

This leads to the question, why if this works so well is the DAMA user even spread at all. The purpose of spreading the signal with unique PN codes is so that when a signal is received it will look orthogonal to all users except the one that generated the code. Therefore, if the DAMA user was not spread and simply transmitted the DAMA receiver would still be able to receive the DAMA. However, the other MA receivers would not be able to receive their requests because the DAMA user would not be orthogonal to the MA

users particular PN codes and therefore the basic principles of CDMA would not be followed. This would hinder the ability of MA users to receive their data. Another factor that must be considered is the Federal Communications Committees (FCC) regulation on the amount of power that can be contained in various frequency ranges. This will also serve as a limiting factor to the rate the DAMA user can be slowed to.

4.4 Recommendations For Further Work

In the above simulations the different cases were evaluated without the presence of noise. This was done because the basic purpose was a proof of concept. However, in reality there will be noise present in the system. Therefore future evaluations should include noise. It is also important to note that the effects on the other MA users caused by the slowing of the chip rate of the DAMA user were not evaluated. This is another area where future investigation and evaluation can be done.

CHAPTER 5: CORRELATOR

One of the primary functions of the receiver is to despread the received PN code [2]. As stated earlier, this is accomplished by generating a local replica of the PN code in the receiver and then synchronizing this local PN signal to one which is superimposed on the incoming received waveform. Modulo 2 addition of the received signal with the synchronized PN code produces the desired despreading process. Up until this point synchronization to the PN code has been assumed to be straight forward as in chapter 3 and Figure 3.5. In the simulations contained in chapter 4, synchronization was done by inspection of the two signals and then delaying the despreading signal by the appropriate amount. However, in reality this is not a trivial solution. In this chapter the actual implementation of correlation will be addressed

The processes of synchronizing to a local PN code is usually accomplished in two basic stages. Initially a coarse alignment of the two PN signals is produced to within a small fraction, usually less than a fraction of a chip. This is referred to as PN acquisition. Furthermore, because of the relative motion of the transmitter and receiver and the instability of clocks, corrections must be made continuously to maintain correlation. This process is known as PN tracking. This process is commonly known as the search/lock method for acquisition [6].

5.1 PN Acquisition

The simplest method of searching is the maximum-likelihood algorithm [2]. In the strictest form, it requires that all input PN codes be correlated with all possible code positions of the local PN code. The correct PN alignment is chosen as that local code phase position which produces the maximum detector output. The disadvantage to this system is that a decision cannot be made until every code phase position has been examined. As a PN code gets long, the time to correlate the signal becomes long. In evaluating the current codes used by the SN, the code lengths used are 2^{11} bits and 2^{19} [7]. These are known as the short and long codes respectively. The problem with using these codes with the maximum-likelihood algorithm is the large amount of time required to examine all possible code phases before making a decision. If a DAMA request was as long as a standard MA transmission this would be no problem. However, in this case because the DAMA request is relatively short compared to normal MA transmissions an entire request could take less time than it takes the PN code to repeat even once. Therefore, if this type of correlator is to be used, in keeping with a simple design, some changes in the DAMA request must occur.

It becomes obvious that if a simple maximum-likelihood algorithm correlator is to be used, the size of the PN code used to spread the DAMA request must become shorter. In the current SN system there is what is called an acquisition PN code used. This code is 256 bits long and therefore much smaller than the other PN codes. This code is generally used to spread an acquisition sequence allowing the receiver to get obtain an initial level of correlation. This leads to the proposed changes for the DAMA requests. Because the maximum-likelihood correlator wants correlation in each code phase, the maximum will occur when the exact code is compared with the local PN replica, and because this acquisition needs to be done quickly for the reasons described above, the following solutions are outlined. First, use the short acquisition code to spread all DAMA requests. This will make it feasible to correlate to the incoming signal quickly. Second, in the request packet send a preamble before the data that contains all zeros. The spread result of this preamble will therefore be the PN code itself. This will allow the correlator to quickly

match the received signal and the replica. Third, use a maximum likelihood correlator for coarse alignment of the DAMA requests. This is the same basic configuration as in Figure 3.5 and below in Figure 5.1.[4] Finally, use an early late gate loop to maintain PN acquisition. This will be outlined in section 5.2 and illustrated in Figure 5.2 [9].

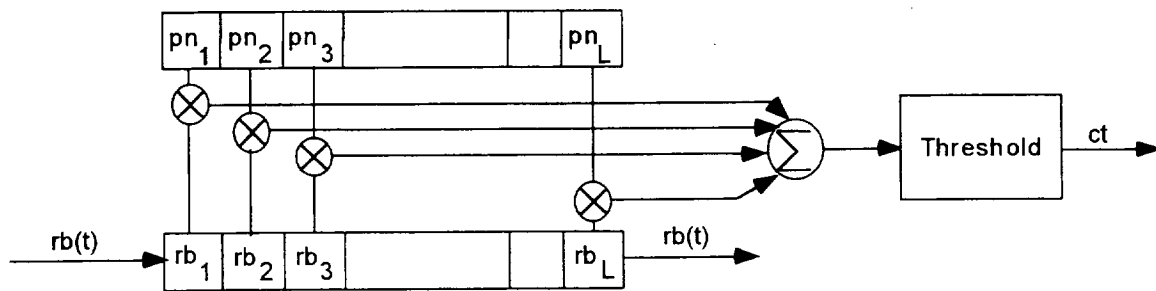

Figure 5.1 PN Acquisition

In this correlator, the local replica is stored in the top register. The incoming spread signal will be shifted through the lower register. A level of correlation is obtained at each code phase. When all the code phases have been examined, the phase that created the maximum level will be outputted. This value is represented in Figure 5.1 as ct , or coarse timing. This is then used to start the despreading process at the correct PN alignment, and is also used in the PN tracking that will be discussed below.

5.2 PN Tracking

Once coarse acquisition has been accomplished and the PN codes are aligned to within less than a chip, the next step is to perform a continuous fine alignment. This is referred to as the PN tracking system. The basic PN tracking system falls into the class of early-late gate types of control loops. The basic baseband configuration of this type of system is shown below in Figure 5.2.[9]

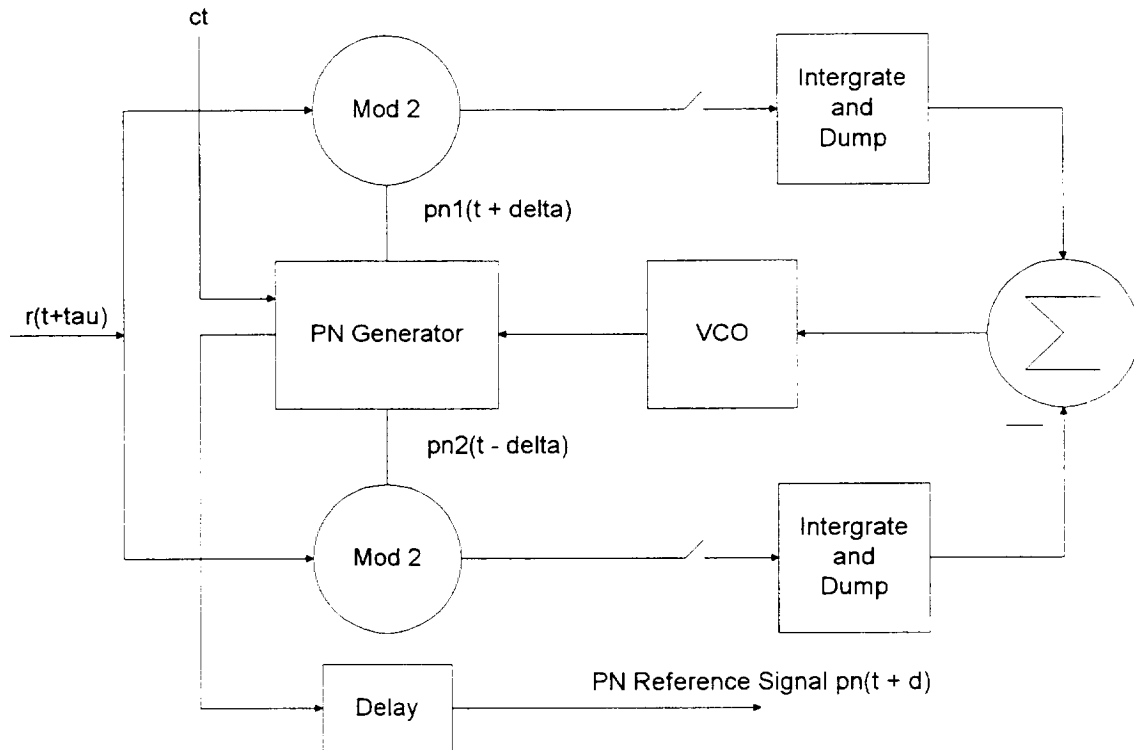

Figure 5.2 PN Tracking

In the above figure, $r(t + \tau)$ represents the received baseband signal that is correlated to within a chip. That is $0 < \tau < T_c$ where T_c is the period of a chip. The goal of the tracking loop is to drive τ to zero thus maintaining perfect alignment. At baseband, this is done by taking the output of the local PN generator (set by the course timing signal ct from the PN acquisition in Figure 5.1) and advancing it by some value (δ) and delaying it by some value (δ) this is listed as $pn1(t)$ and $pn2(t)$ respectively. These values are then modulo 2 added to the incoming PN received signal and then integrated over a chip period. The values are then summed together to find a level of error. This value is then passed into a VCO, much like a PLL, this value of error drives the VCO. Finally the output of the PN code generator is transferred with the proper delay (d) that will represent the timing error to offset τ . This value is represented as $pn(t + \tau - d)$. The loop will continuously determine a value of d that will counter the value of τ . Therefore, the resulting value of the PN code seen by the despreader will be $pn(t)$.

CHAPTER 6: DATA PROCESSING REQUIREMENTS

After the receiver receives a possible DAMA user the data must go through numerous steps to verify and check the request. The following is a list of steps the data must undergo before a service can be scheduled.[3] This is also illustrated in Figure 6.1

1. The user must have a valid authorization to use the SN. The system will check to see if the incoming request is that of a SN DAMA user rather than that of an unauthorized user trying to gain access to the system.
2. Determine the priority of the request.
3. The system will then determine if the type of service requested is valid for the SN, that is, did the satellite request a service that can be supplied by the SN.
4. The next step is to determine if the request is valid for that particular user. A database will be used that contains all the satellites using the system along with the various capabilities of the satellite. Based on the satellite, the system will need to determine if the type of service that is requested by the satellite matches the satellites specifications. That is, if a satellite requests service on a SA channel but has no ability to transmit on that channel then that service can't be supplied.
5. The next step is to predict the orbital parameters of the satellite. This is done so that the system can determine if a relay satellite will be in view of the user satellite at the time that service is requested. This can quickly be done on a standard personal computer. The computer will obtain the needed parameters for the particular satellite from a data base. The orbital characteristics can then be found using a variety of commercially available orbital prediction software packages.

6. Once all the above checks are complete and the requirements are met, the system must contact the scheduling computer to determine if the requested time slot and channel are available for the service.

7. At this point, there are two possibilities. Service is not available at the particular time and/or channel or service is available. Once this is determined the satellite owner will be contacted with the request information and the availability of service. At this point, the owner has many options. First, if the owner determines that service is needed and is available, the service will be requested. The scheduling computer will inform the SN of the confirmation and the service will be set up at the appropriate time. The WSGT will then send a confirmation of request to the satellite through a forward link. Second, if the service is not needed the owner will inform the SN that no service is desired. The WSGT will then send a denial signal to the satellite informing it that no further action will be taken. Finally, if the owner determines that service is needed but the SN does not have the resources the owner and the SN can determine if an alternate service can be incorporated into the SN schedule. If another service is available the WSGT will then inform the satellite what service the satellite will use.

This process is easily implemented with standard commercial off the shelf (COTS) software and hardware. This flow is important because it must be able to quickly estimate many parameters. Many of these steps can be done in parallel to increase the speed of the processing. It is also important because the scheduling system at GSFC must be aware of all the information obtained in these above process in order to schedule an effective service on the SN.

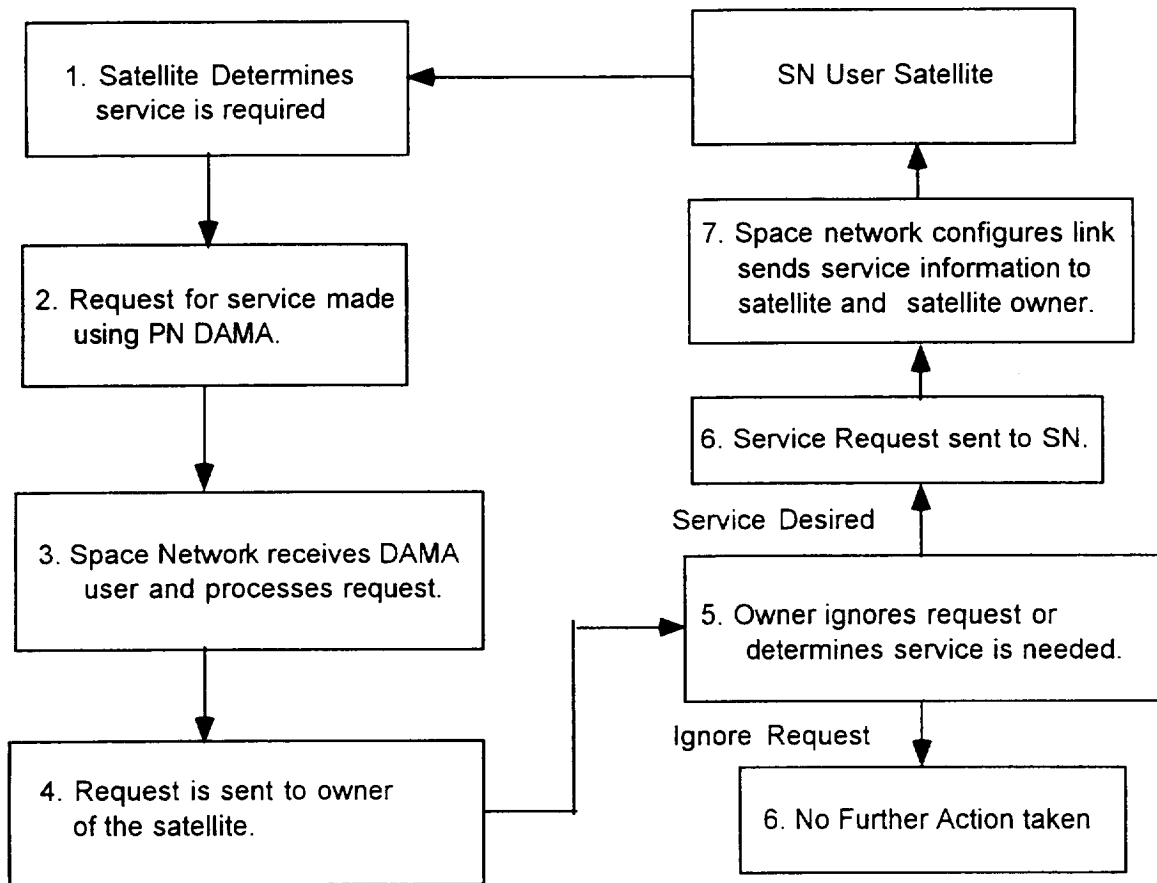

Figure 6.1 Operational Flow of DAMA Request

CHAPTER 7: CONCLUSIONS

The implementation of this new receiver will allow for reception of the random access requests, i.e. DAMA requests. This is possible because of the modifications and changes made to accommodate this new service. First, by using only a single element of the phased array antennas contribution provides the necessary global coverage as well as link margin. [1] Second, the new method of detecting a possible DAMA user and then predicting the users carrier frequency requires the chip and data rates of the DAMA user to be slowed relative to other MA users [4]. This change will only help to improve the ability of the receiver to receive the DAMA requests. This is primarily due to the ability of reducing the cutoff in the LPF for demodulation thus, reducing the interference caused by other MA users. Finally, using the shorter PN code along with adding the acquisition preamble to the request allows for a simple and efficient method of correlating the incoming signal with the local PN replica.

When all the above changes are put together the result is a relatively simple as well as inexpensive method of implementing the new DAMA service. The amount of hardware for this new service is minimal. The processing of the new services can be implemented in software and the remaining SN is unaffected by the changes. Overall this seems to be a viable as well as interesting solution.

REFERENCES

- [1] Caballero, Rubén, Horan, Stephen, "TDRS MA Phased-Array Antenna Simulations," NMSU-ECE-95-013, NASA, Las Cruces, New Mexico, May, 1995
- [2] Feher, Kamilo, Wireless Digital Communications Modulation & Spread Spectrum Applications, Prentice-Hall PTR, Upper Saddle River, New Jersey
- [3] Horan, Stephen, "An Operational Concept for Demand Assignment Multiple Access System for the Space Network", NMSU-ECE-96-007, NASA, Las Cruces, New Mexico, May, 1996
- [4] Horan, Stephen, Introduction to PCM Telemetry Systems, CRC Press, Boca Raton, Florida
- [5] Sanchez, Monica, "Demand Assignment Multiple Access Service For TDRSS" NMSU-ECE-96-006, NASA, Las Cruces, New Mexico, May, 1996
- [6] Simon, Marvin; Omura, Jim; Scholtz, Robert; Evitt, Barry, Spread Spectrum Communications, Volume 3, Computer Science Press, Inc., Rockville, Maryland
- [7] NASA , "Space Network (SN) Users Guide," Revision 7, Goddard Space Flight Center, Greenbelt, Maryland, September, 1988
- [8] TRW, "Tracking and Data Relay Satellite System Operational Overview," Report 1, NASA, Las Cruces New Mexico, May, 1992
- [9] Viterbi, Andrew J., CDMA Principles of Spread Spectrum Communication, Addison-Wesely Publishing Company, Reading, Massachusetts