

NASA-CR-702119

11-4-96
74324

DEPARTMENT OF AEROSPACE ENGINEERING
COLLEGE OF ENGINEERING & TECHNOLOGY
OLD DOMINION UNIVERSITY
NORFOLK, VIRGINIA 23529

**VIRGINIA SPACE GRANT CONSORTIUM UPPER
ATMOSPHERIC PAYLOAD BALLOON SYSTEM (Vps)**

By

Bryan E. Marz, Project Manager

Principal Investigator: Robert L. Ash

Final Report
For the period ended January 31, 1996

Prepared for
National Aeronautics and Space Administration
Headquarters
Washington, D.C. 20546

Under
Research Grant NAGW-4339
Gordon Johnson, Technical Officer

August 1996

Old Dominion University Research Foundation



DEPARTMENT OF AEROSPACE ENGINEERING
COLLEGE OF ENGINEERING & TECHNOLOGY
OLD DOMINION UNIVERSITY
NORFOLK, VIRGINIA 23529

**VIRGINIA SPACE GRANT CONSORTIUM UPPER
ATMOSPHERIC PAYLOAD BALLOON SYSTEM (Vps)**

By

Bryan E. Marz, Project Manager

Principal Investigator: Robert L. Ash

Final Report
For the period ended January 31, 1996

Prepared for
National Aeronautics and Space Administration
Headquarters
Washington, D.C. 20546

Under
Research Grant NAGW-4339
Gordon Johnson, Technical Officer

Submitted by the
Old Dominion University Research Foundation
P.O. Box 6369
Norfolk, VA 23508-0369



August 1996

Acknowledgment

The following is a list of names of people who have contributed to the successful planning, preparation, and launch of the Virginia Space Grant Consortium Upper Atmospheric Payload Balloon System (Vps). Without the contributed efforts of these people and others who gave their time and experience, this flight could not have happened.

NASA/Goddard Space Flight Center/Wallops Flight Facility

Douglas P. Bell

Richard H. Bradford

Granville L. Taylor

Physical Science Laboratory/Wallops Flight Facility

Michael Martone

Physical Science Laboratory/National Scientific Balloon Facility, Palestine, Texas

Mark D. Cobble

Arthur H. Gusa, Jr.

Virginia Space Grant Consortium

Mary Sandy

Patrick Golden

Old Dominion University

Dr. Robert Ash

Dr. Sebastian Bawab

Dr. Glenn Gerdin

Bryan E. Marz

Charles Leonard

Cynthia Blackburn

Thomas Pepin

Benjamin Pedersen

Peter Cantrill

Ron Maxson

Dan Edwards

Matt Radcliff

Ki Pak

John Christodoulou

Steve Andresen

Stephanie Blair

Richard Griffin

Jim Jenkins

Ramon Rodriguez

William Thomas

Mark States

Kenneth Patton
Edwin Labrador
Peter Lunde
William Nason
Warren Blanco
Civarath Tum
Hahn Nguyen
Ken Demby
Joyce Lomax
Ana Maria Barbeito
Farid Fallaha
Steve Summers
Dave Johnson
James Miller
Jeffery Schrecengost

Hampton University

Dr. Nelson Jalufka
Justin Bonaparte
Shannon Teasley
Chekesha Clingman
Desiree Batth

College of William and Mary

Dr. Dennis Manos
Dawn Guilmet
Terry Gruchow
Brent Justus
Meg Chase
Andy Meyer
Michael Johnson

Purpose

This document provides a summary of the launch and post-launch activities of Virginia Space Grant Consortium Upper Atmospheric Payload Balloon System, V_{ps} . It is a comprehensive overview covering launch activities, post-launch activities, experimental results, and future flight recommendations. It is maintained by the Project Manager.

Post-Launch Report Outline

I.	Launch Activities	2
II.	Post-Launch Activities	9
III.	Experiment Results	12
IV.	Recommendations	42
V.	Footnotes	44
VI.	Acronym Definitions	45
VII.	Appendix	
	A. Schedule	46
	B. Final Design Review Action Items	47
	C. Tentative Schedule Form	56
	D. Launch Checklist	57
	E. Fortran 518 code	58
	F. Payload Assembly Drawings	60

I. Launch Activities

Launch activities began following the Final Design Review in which suggestions and recommendations were submitted for consideration and action. After the incorporation of these action items, the Payload schedule, Appendix A, shows that the Mission Readiness Review, responses to comments from the Mission Readiness Review, scheduling of launch, and performing final steps for the launch are needed to be completed. This report covers these items in detail for future flight reference.

Following the April 26, 1995 Design Readiness Review, a list of suggestions was submitted to the Payload team, Appendix B, from the design review board consisting of members from Wallops Flight Facility, NASA Langley, faculty professors, and personnel from industry firms volunteering their time and expertise. These items were reviewed by the project manager and directed to the individual teams in which they affected. At this time, the Payload design, construction, and assembly are complete and scheduling of the Mission Readiness Review can be done.

The Mission Readiness Review, MRR, is the review of the final product by engineers and staff at Wallops Flight Facility, WFF, and NASA Langley for final approval of flight readiness. The date for the MRR was set for July 25, 1995. At the MRR, action items and recommendations were given for the Payload team to resolve or answer before flight approval would be given. Below is the list of the action items and recommendations submitted. Note that only the action items needed to be done and that the recommendations were strong suggestions for consideration. However, all responses must be addressed and

a reply to each needed to be answered and submitted to the MRR board.

1. The action items identified by the Science Team during the presentation on Payload Electrical Control and Data Acquisition System should be successfully completed as planned.
2. Since some uncertainty exists on the radiative properties of the Spectron 12 payload suspension cable system, it should either be replaced by one that is structurally acceptable but not radiation degradable or wrapped with white tape to protect it from ultraviolet radiation.
3. The WFF Operations Team shall ensure that a link analysis has been performed on the flight control command system(s) being employed to verify that sufficient margins exist for the planned operation.
4. The WFF Operations Team should ensure that standard National Scientific Balloon Facility, NSBF, procedure are employed for check and balance on critical operations such as inflation calculations, flight line procedures, etc.
5. The WFF Operations Team shall ensure compliance with NSBF processes for certification of ground launch equipment.
6. Code 824/Safety & Quality Assurance Engineering Branch personnel will be generating an addendum to the Safety Plan to address requirements for safe handling of the Lithium-Sulfur Dioxide batteries. This document will provide procedures which the Science and WFF Operations Teams will be required to follow and enforce.
7. It would be highly desirable to perform a first order thermal analysis on the science flight systems to ensure that predicted subsystem temperatures do not exceed subsystem performance specifications.
8. The WFF Project Manager and Science Team should consider performing a thermal-vacuum test at WFF on the laser experiment to evaluate its performance under the expected flight conditions.

Regarding the given action items and recommendation, the following comments or actions were taken by the Payload team. For action item one, problems with the GPS card, boot chip, and voltage offsets were solved. These were done with the help of personnel at

NASA Langley. Action item 2 was corrected by using steel cable supplied by NSBF. Action items' three through six were the responsibilities of WFF and addressed by them. Recommendation seven was completed by Dr. Robert Ash, with Chuck Leonard reviewing his calculations and approach. Recommendation eight was not done for the following reasons: Due to time constraints set by the remaining launch window and by in-house testing performed on components after the first thermal test, demonstrated that the need for a full Payload assembly thermal test would not be needed or feasible. With all items having been reviewed and proper action taken and documented, communication with WFF was done to schedule the date for launch.

In setting up a date for the launch, several factors have to be considered. Student availability, launch pad availability, and weather are the most important. In consideration for students work and school schedules, all students were asked to fill out a form, Appendix C, stating a tentative schedule during the available launch window.

Launch pad availability was determined based on several factors. At the time of the Payload project, another school, University of Pennsylvania, was also trying to launch their balloon project and a commercial rocket was also preparing for a launch. WFF has certain procedures to follow with regard to launch, one being that 24 hours must stand among all separate launches due to concerns of safety and scheduling of launch personnel. The most important criterion for setting up a launch is the weather. Detailed forecasts are observed and used to project upcoming weather conditions. Certain conditions like cloud cover, low level wind speeds, wind directions all are observed and used to evaluate launch feasibility. Using all the above criteria helps set a date, and, even then, the final decision can be made

only 1-2 hours before the actual launch will be a go. With a launch date set, the next step was to submit all information requested by WFF and NSBF for launch preparation and to prepare a launch checklist.

On the launch date, WFF requires that all pertinent personnel be present at all times on location. For the first balloon launch, all students and faculty were required to be present one day before the launch date. The purpose of this was for WFF and NSBF to make a final visual approval of the Payload and to have all necessary Payload personnel available to answer any questions that arose.

In confirming the launch feasibility, the day prior to launch two weather briefings are held – one at 9:30 a.m. and one at 1:30 p.m. – to check conditions and determine if they fall within acceptable launch conditions. Students and faculty were invited to be present at these briefings in order to observe the launch preparation activities and update any Payload constraints. During the first day, the actual Payload weight was obtained by NSBF personnel for use in calculating the necessary Helium needed for the balloon. The formula used incorporates the weight of the Payload, WFF equipment, and is multiplied by a constraint factor to calculate the lift weight needed and finally the volume of Helium required. The final weight of the Payload system was 95 pounds, 5 pounds under the allotted 100 pounds constraint.

Paperwork was processed and given to the two students who were to fly in the chase plane after launch. This flight would occur when the Payload was approaching the approximate location for cut-down. The chase-plane personnel had the responsibility of inspecting the Payload upon retrieval and of performing any necessary shutdown sequences.

The next pre-launch test was to perform a flyby radio frequency test. This test verified that any payload transmitting equipment did not emit signals that would interfere with transmissions between the plane and NASA support personnel in sending the cut-down command. Due to a last minute design change for the hot-wire experiment, no transmitter was used on the Payload system so this test was not needed. Having met all the required conditions and answered the questions to satisfy WFF and NSBF, a launch checklist was prepared and the Payload was made ready for launch.

A detailed description of the launch time table and the sequence of events, as they occurred for the second launch attempt is as follows. Approximately 3-4 hours before the scheduled launch a few WFF personnel come in to work. Their jobs include checking weather conditions to make sure launch is still feasible. About 2 hours before launch the main crew begins to arrive and start preparing for launch. About this time the Payload team also arrived to do any last minute setup necessary and start running through the launch checklist, see Appendix D. At a predetermined time, 1-2 hours before launch, the Project manager and those directly needed for operating the Payload must be present onsite at all times until launch. This is necessary because of the short time frame and communication between the project and the launch personnel is crucial for answering questions on launch conditions or system readiness. Launch can be aborted at anytime up to the time when helium is being filled into the balloon, so accessibility is very important. Once the Payload was ready for launch, approximately ½ hour before scheduled launch, the system was taken outside the hanger and turned on. This was done to allow the GPS system to locate nearby

satellites and get a lock, to make sure valid data would be taken throughout the flight. Once lock is obtained, the Payload is left alone and balloon release is all that is left.

A description of the successful Payload launch is as follows. The Payload was fully functional and ready for launch. Weather was deemed acceptable and the Payload was taken out of the hanger to the launch pad. The WFF and NSBF personnel laid out the stratospheric balloon, which is approximately 2-4 mils thick, on a tarp to prevent it from tearing. They then proceeded to attach the passive restraint parachute to balloon, followed by the radar tracking mesh and system control box. The control box was then attached to the ladder train leading to the Payload system. The approximate length from the Payload to balloon was 90 ft. This activity can be seen in figure 1.1 and in the presentation video created from the second launch. With everything in place for launch, a final evaluation was made and Helium

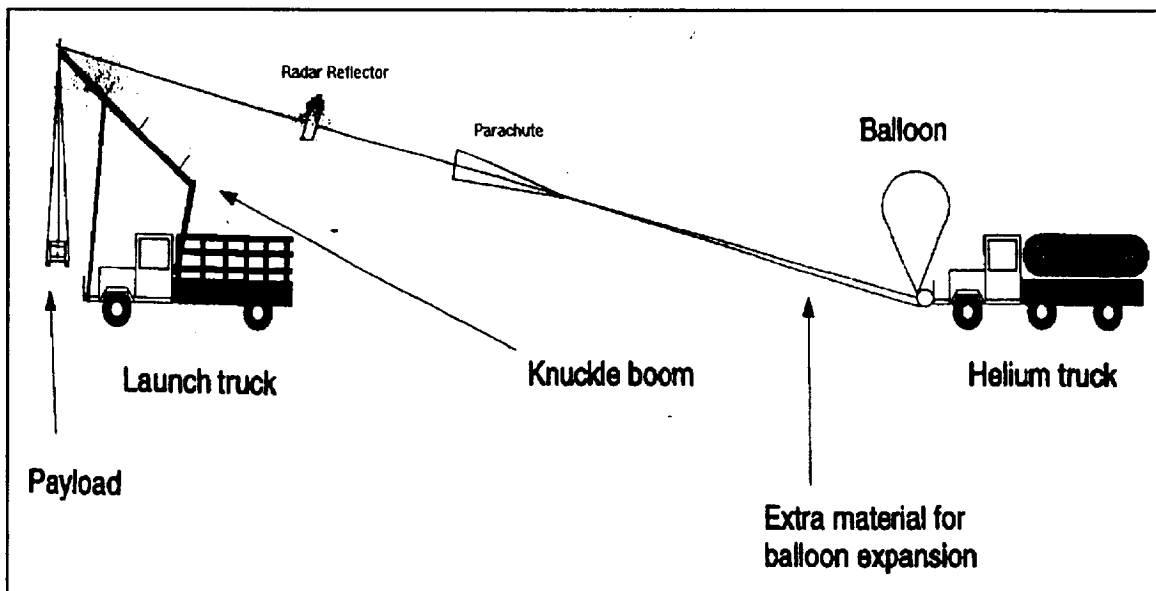

Figure 1.1 Balloon Launch Setup

was valved into the balloon. The total time required to charge the balloon was approximately 20 minutes; and at that time, the inflated balloon had a diameter of approximately 30 feet. At the front of the helium truck, a spool was attached that held the balloon in place during filling. To launch the

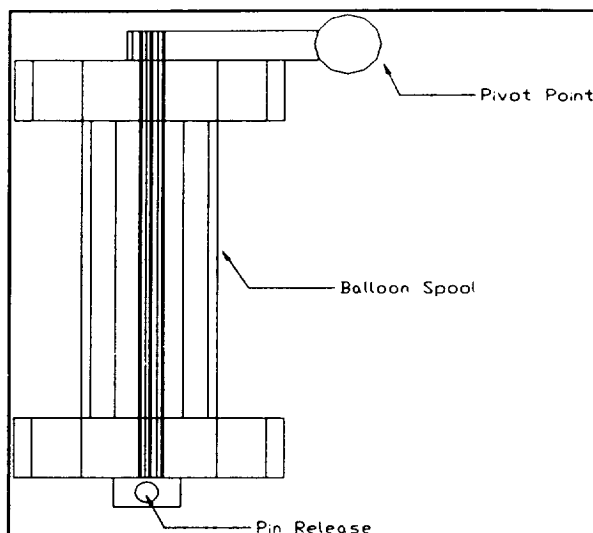

Figure 1.2 Spool Launch Device

balloon, the spool was detached by a pin on one side allowing it to swing open and no longer constrain the balloon from lifting off, see figure 1.2. After releasing the balloon, the launch vehicle was driven in order to remain underneath the balloon, but behind it in terms of the direction of the wind. In that way, the balloon could lift off and move away from the front of the vehicle.

Once the balloon had obtained maximum altitude, 96,500 ft., its float trajectory was calculated and the desired balloon location for cut-down was established. Tracking continued until touchdown at which time a retrieval vehicle was sent out to the approximate landing location, in order to locate and retrieve the payload and parachute. The Payload was retrieved approximately 3 miles away from Wallops Island. The actual landing was observed by faculty, students, and WFF personnel and the Payload was undamaged upon impact.

II. Post-Launch Activities

Having completed the successful launch and recovery of the Payload system, a review of the post-launch activities performed and areas addressed are presented. This section details those actions performed at the time of Payload recovery and by the individual teams after recovery.

In preparing for the Payload recovery, a checklist was created to guarantee the safety of the personnel during retrieval and make sure that proper actions were taken to preserve the integrity of the experimental samples and data. The onsite checklist is presented below in the order performed, with explanation of their importance.

1. **Disconnect canister battery - disconnecting first to prevent possible discharge of canister valves while inspecting Payload and performing shutdown procedures. Safety precaution: battery presents concern for explosion of chemical leak.**
2. **Disconnect Data Acquisition battery - disconnecting second to stop recording of data and to preserve existing battery life. Safety precaution: battery presents concern for explosion of chemical leak.**
3. **Disconnect Hampton University battery for laser experiment - safety concern for handling Payload.**

4. Removal of Data loggers - three self-contained data loggers are used in the Hampton University experiment and are removed from Payload for data retrieval
5. Remove the nine College of William and Mary experiment canisters - necessary for immediate transpiration and sample collection due to possible leakage or gassing of aluminum canisters

Following the retrieval of the Payload system, the three experimental teams began their post-launch analysis of supplied data. Additionally, data analysis and retrieval of the data acquisition system for use by the three teams were being performed.

The data acquisition team, led by Dr. Gerdin, took back the computer and perform the following analysis. Retrieval of the hot-wire anemometer experiment data was retrieved. This data entails the entire Global Positioning System (GPS) data and all stored data from the hot-wire probes. For the College of William and Mary, the recorded time lapse and positions of the canister sampling were retrieved. This information included both the barometer and GPS data for altitude comparison. Finally, for Hampton University, the entire altitude profile and redundant data logger information were retrieved. In addition to specific data for each team, all pressure, Payload thermal, and computer section thermal readings were retrieved for base reference. To accomplish this data retrieval, two programs were developed by the ECE team. One program converted all the data recorded by the data acquisition involving the thermal, pressure, and backup data loggers with the other program converting the GPS data into a form useable by all teams.

The hot-wire experiment, led by Dr. Ash, will evaluate the hot-wire probe data and plot this information against the GPS data. The altitude sampling experiment, led by Dr. Manos, will retrieve the samples taken during the ascent and perform analysis to determine what compound can be found at different altitudes. The water density experiment, led by Dr. Jalufka, will evaluate the data recorded on the data loggers and compare this with the redundant data stored by the data acquisition and plot against the GPS altitude profile. The detailed information regarding what analysis was done and the results and conclusions of these experiments are presented in section III.

III. Experiment Results

This section will detail post-launch results obtained through analysis of the experiments and data acquisition team. An overview of what the experiment was to do and results of the experiment will be presented. Additional comments on data reliability or thoughts for improvements will also be included.

Electrical and Computer Engineering data acquisition team

Introduction

The role of the ECE students was to design, build, test, and operate the taking and retrieval of scientific data relating to the physics and chemistry of the upper atmosphere. The balloons are to be launched from NASA's Wallops Island Facility on the Eastern Shore, which will drift westward over Virginia at an altitude over 70,00 ft., for approximately 8 hours. Temperature extremes will be between -40 to +100 degrees Celsius, and the pressure will range down to 1 to 10 millibar.

The electrical and computer engineering part of this projects involves three separate tasks: 1) Data Acquisition and Storage, 2) Gondola and System Electrical Power, and 3) Transmission of digital data from a small package located up to 3000 ft below the gondola, and its reception by the data acquisition system for storage.

1) The Data Acquisition System Task:

Student Teams:

Fall Semester '95: Peter Lunde and William Nason

Spring Semester '96: Ms. Ana Maria Barbeito and Mr. Farid Fallaha

Summer '96: Mr. Steve Summers and Mr. Dave Johnson

During the fall semester it was decided that the data-acquisition system would be a 386 SL based system with solid-state flash-ROM hard drive for permanent storage of the data taken during the balloon flight. The hardware was to include 1) analog to digital converters to read sensors for temperature, pressure, and wind-speed directly and convert into digital form for storage, 2) time and position in digital form from a Global Positioning Satellite System (G.P.S.) antenna and board, and 3) the data in digital form from the radio receiving data from the small package below the gondola. These items were ordered in the spring semester, and didn't arrive until April.

The spring-semester student team (Barbeito and Fallaha) was to write the program that acquires all this data, and stores the desired portion in the hard drive, and activities the opening and closing of the gas sampling bottles when the proper altitudes were reached. However, since the hardware arrived so late, there was no time to check out their program, so this effort was unsuccessful. This endeavor was continued during the summer by Steve Summers and Dave Johnson.

2) The Gondola and System Electrical Power Task:

Student Teams:

Fall Semester '95: Mr. Kevin Demby and Ms. Joyce Lomax.

Spring Semester '96: Mr. Hahn Nguyen, Mr. Ron Blanco, and Mr. Civarath Tum.

Summer '96: Mr. Ron Blanco.

The power team was to insure that electrical power, in the form of DC batteries, was supplied to the data acquisition system, the gondola sensors, and a power pulse is transferred to the solenoids which open and close the valves on the William and Mary atmospheric sampling experiment. The latter involves the translation of the computer coded message into the opening of a specific valve, out of eight possible valves. Other issues are the performance of the lithium batteries under the extremes of pressure and temperature, and the possible need to stop the flow of currents to components or experiments which short out.

3) 'Generic' atmospheric sensors on the main gondola.

Student Teams:

Fall Semester '95: Mr. James Miller and Mr. Jeffery Schrecengost.

Spring Semester '96: The power team, (i.e., Blanco, Nguyen, and Tum) also assumed this task.

During the balloon flight, at different times the atmospheric pressure and temperature were to be recorded. These students determined the type of sensors to be used, and designed and tested the signal-conditioning circuitry so the electrical output of these sensors would

properly interface with the A/D converters.

- 4) Transmission of data from the anemometer package to the data-storage unit aboard the main gondola.

Student Teams:

Spring Semester '96: Mr. James Miller and Mr. Jeffery Schrecengost.

Summer '96: Mr. Alan Alexander.

A small package was to be lowered from the main gondola to measure the velocity of the wind away from the balloon and gondola. It is believed that the balloon and gondola travel in their own air mass, so sampling wind velocity at the gondola, would not give meaningful data. The task of this team was to convert the wind-speed data from analog to digital form and transmit it back to the gondola, and receive it and make the data to the data-acquisition system.

Actual Flight System

Anemometer Experiment Data Acquisition

During June of 1995, it was decided that transmission of data from a separate payload hung a mile below the gondola was not feasible with the resources available, so putting the anemometers on a boom, sticking out horizontally from the payload was planned. The output of the anemometers was sent over coaxial cables to the anemometer control board designed

by Chuck Leonard and built by Tom Galloway in the ODU Engineering College Electronics Shop. The output was passed through a 100 Hz bandwidth 6th order Butterworth anti-aliasing filter. The analog signal output from the filter was fed into the Motorola 6811 micro controller which was programmed by ECE student Alan Alexander, to continuously sample the anemometer signal voltages and make them available continuously on parallel output cables. These data then could be read by the main 386 computer as a parallel read of the data at I/O address 300 and 301 hex, through a parallel I/O board wired by Professor Gerdin of ECE. These data were read at a rate of 500 Hz and stored in the flash memory by part of the program written by ECE students Steve Summers and Dave Johnson to control the electrical and computer system during the flight.

Global Positioning System Data Acquisition

Once the GPS system microcontroller acquires enough satellites to be in the acquisition mode, a 64 word train of serial data is sent to one of the serial ports of the main 386 computer at a rate of 1 Hz. These data are momentarily stored in a local buffer until the message is complete, and then they are transferred to the flash ROM for permanent storage and time stamped with the local CPU time in a separate file for the G.P.S. This operation of the main 386 CPU was programmed by ECE students Steve Summers and Dave Johnson as part of the program to control the electrical and computer system during the flight.

Acquisition of Pressure, Temperature, and the Output of the Hampton University

Experiment and the William and Mary Experiment

After the GPS data train was received, the CPU then read the atmospheric pressure (baratron) and temperature (thermistor) and the voltage outputs (2) from the Hampton University experiment were acquired through the 518 data acquisition board which interfaced the signal conditioning circuitry (analog) for these various measurements and the CPU. These data were time stamped with the local CPU time and stored in the flash memory in a separate file. The baratron voltage (which is the atmospheric pressure in Torr/100) was compared with a look up table corresponding to pressures at altitudes where the William and Mary investigators desired to have a gas sample taken. If the pressure was in the range for such a sample, a number was sent to a decoder address in the parallel I/O board which subsequently opened a unique gas sample bottle for 10 seconds to sample the atmosphere at that altitude. The 518 data were then stored and time stamped along with bottle number and store in a separate file in the flash memory. Again, all these main 386 CPU operations were programmed and tested by ECE students Steve Summers and Dave Johnson.

System Integration

In attempting to launch by August 8, 1995, virtually no time was available to integrate the various experiments from the different schools prior to the launch preparation at Wallops Island. Since ODU controlled the electrical operation of the William and Mary experiment, there was no problem there, but the output of the Hampton Experiment was not

under our control (except that we supplied them with +15 volts and -15 volts DC power) and here the unforeseen 'charge-up' problem developed. After electrically connecting all the system components together for the first time the pressure and the temperature sensors read high by about 1.5 volts. Since the pressure signal was being used to determine when the William and Mary valves would open and close, this experiment would be jeopardized along with the Hampton University output voltages which probably would be in error as well. It wasn't until August 13, 1995 after the August 8, 1995 flight was scrapped that the problem that the Hampton University outputs were at about +14 volts, which was higher than the 518 data acquisition board running on + and - 12 volts could take (and way beyond the maximum voltage they could read of +5.7 volts). Using a voltage divider to reduce the Hampton University inputs by a factor of 1/3.167, the electrical and computer system worked as designed, resulting in a highly successful flight.

Aerospace Engineering hot-wire experiment

INTRODUCTION

The focus of this experiment is to investigate the capability of the Global Positioning System (GPS) as a device for measuring turbulence in the upper atmosphere. It is important to understand turbulence because it is one of the primary processes affecting atmospheric dynamics. Among other things, it is associated with increased transport of pollutants, heat, mass, and momentum. Turbulent influences can be obvious, such as when they affect the

flight of aircraft, or turbulent effects can be widespread, such as when they are responsible for global weather patterns. Effects of turbulence can also be subtle, affecting the propagation of radio waves, light, and sound in the atmosphere [1]. The presence of turbulence is so profound that "there is a consensus amongst meteorologists that turbulence is the root of all the difficulty they are facing in forecasting the weather beyond a few days [2]." However, turbulence data is difficult to obtain at altitudes above 100,000 ft. The difficulty arises from both flight vehicle and traditional instrumentation limitations. In an attempt to fill the data gap, the use of GPS is investigated.

A description of the GPS using a single non-precision receiver is given below. Testing was also undertaken to compare turbulence data from the GPS with that of a simultaneously operating constant temperature hot-wire anemometer, the conventional tool for turbulence measurements. The correlation between radar and GPS data is investigated over the ascent portion of the flight. Due to the limitations of a single non-precision receiver in absolute positioning, a method employing relative differential positioning is proposed to capture turbulence data.

THE GLOBAL POSITIONING SATELLITE SYSTEM (GPS)

The Global Positioning System satellites orbit the Earth every 12 hours at an altitude of 20,200 km. In Figure 3.1 (Peter H. Dana, The Geographer's Craft Project, Dept. Of Geography, University of Texas Austin), four GPS satellites are depicted in each of six orbital planes inclined at approximately 55 deg with respect to the equator [3]. Twenty-one

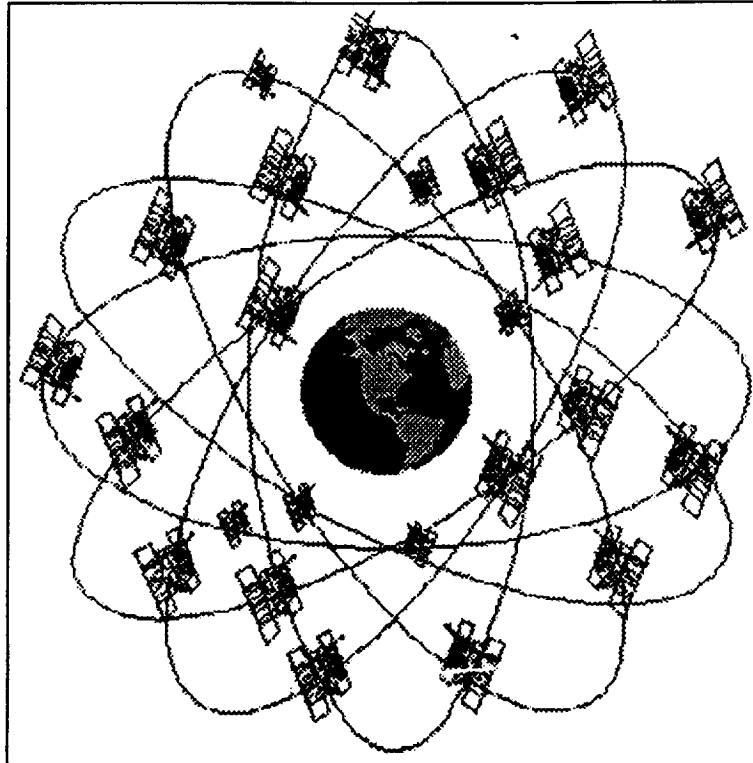

Figure 3.1 G.P.S. Satellites Orbit

satellites are operational with three additional satellites acting as spares. They are arranged so that at least five satellites are in view simultaneously for any user located on the Earth's surface.

G.P.S. Receivers are radio-receivers/computers which measure the time that the radio signal takes to travel from a GPS satellite until it arrives at the GPS antenna. For this test, a Rockwell NavCard with PCMCIA interface was used. Functionality was verified against a hand-held Magellan 3000 GPS receiver. Using the travel time multiplied by the speed of light provides a calculation of range to each satellite in view. From this and additional information on the satellite orbits and velocity, the internal GPS receiver software calculates its position through a process of triangulation. Information from four satellites can

provide three-dimensional position, velocity, and time data.

G.P.S. satellites determine position by employing the time delay of signals from the satellites to the receiver. When turned on, the receiver initializes itself by locating each of the satellites in view. To locate the proper satellites, the receiver consults its almanac, an electronic listing of specific satellites and their locations for given days and times. If the receiver has not been used recently or has been transported more than a couple of hundred miles away from its previous position, it could easily take ten minutes or longer to initialize. This is known as a cold start, whereby the receiver must randomly search through it frequencies to determine which satellites are overhead. The initialization can be expedited by inputting the approximate date, time, and latitude or longitude. During the initialization, the receiver obtains clock times from the orbiting satellites (which keep time using four internal atomic clocks). The clock times are used to initialize the receiver's internal clock for the purpose of navigation. The method of operation for positioning is relatively simple. Assuming perfect conditions, the signal from the satellite should arrive at the speed of light. Therefore, the time elapsed between the GPS satellite sending the message and the receiver obtaining the message yields the distance between the satellite and the receiver which can be represented as points on the surface of a sphere. This is known as a pseudorange. When this process is repeated with multiple satellites, the pseudorange spheres intersect, as shown in Figure 3.2 (adapted from Rockwell NavCard Designer's Guide, page 1-4, May 1994). The

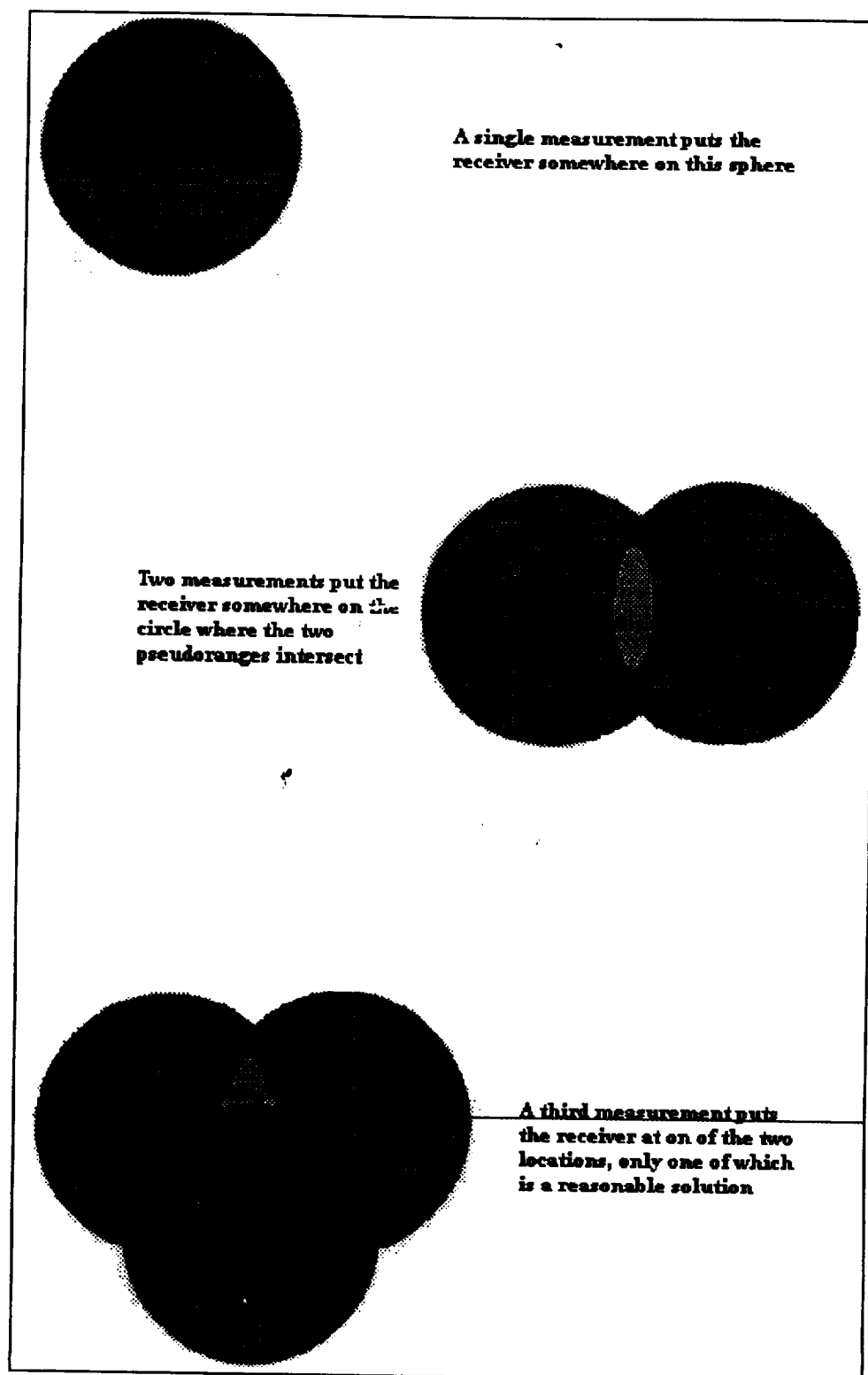

Figure 3.2 Pseudorange spheres

receiver is thus located at the point of intersection. Changes in the pseudoranges over short time intervals are used to compute the velocity of the receiver. Position, time, and velocity data are generally updated once a second. Unfortunately, measurements are not totally accurate, particularly without the use of a precision code receiver. To improve the accuracy, a technique called Differential GPS (DGPS) is used. By having a receiver at a known location receiving signals from the same satellites as an object at an unknown location, one can correct the error present in the measurement.

For the present project, another type of DGPS is employed. Whereas the differential technique above requires information other than that provided by the GPS itself, the proposed system uses only the GPS receiver. No longer is the system running in an absolute positioning mode where latitude, longitude, and altitude are sought. Instead, it runs in a relative positioning mode. Relative differential GPS utilizes the difference between consecutive measurements of a single GPS to track turbulent motions. Now, precision is the critical parameter rather than absolute accuracy. The system need not provide exact location fixes but exact differential locations.

For example, consider point A located at a position (0,0) and point B positioned at (0,5) in x, y space. If the GPS system measures the location of point A as (0,1) and point B as (0,6), the system has correctly determined the distance between A and B. Thus, any turbulent motion taking a flight vehicle from point A to point B would be properly represented. Combining the position data with the times of the measurements allows one to compute the velocity and thereby compute the turbulence. Using a relative differential approach, the incidental sources of error such as ionospheric and tropospheric delays are

effectively eliminated as the signal is passing through roughly the same airspace for each measurement. The greatest obstacle to successful measurements is then the intentional variation of the signal. If the signal were consistently offset, the differential technique would be completely accurate. However, since the error is imposed by a random signal, the accuracy is limited to the greatest variation broadcast.

HOT-WIRE ANEMOMETERS

Hot-wire anemometers are one of the most common tools used to investigate turbulence. They are chosen because they possess excellent frequency response (up to 1 MHz) and good spatial resolution [4]. Their disadvantages are their fragility and the requirement that the sensor be placed in the flow being measured (which can alter the flow). Hot-wires are operated principally in two modes: constant current and constant temperature. A constant temperature anemometer was employed here and will be described briefly. The basic anemometer circuit is shown schematically in Figure 3.3 while a schematic of the actual circuit adapted from Miller [5] appears in Figure 3.4.

The principle of operation is simple. A small metal wire serves as an electrically heated sensor. The sensor is selected to operate at a given temperature by adjusting the resistance on the other lower leg of a bridge circuit. This temperature must be higher than the ambient temperature. The ratio of the sensor temperature to the ambient temperature is referred to as the overheat ratio.

An overheat ratio of 1.8 is common although values as low as 1.2 are used in low

speed flows in order to prevent excessive heat loss (and errors) due to free convection. As fluid passes over the sensor, the metal wire is cooled by forced convection. This cooling causes a drop in temperature which lowers the resistance of the wire and thus lowers the potential at point 2 of the operational amplifier. The lowered potential at the negative terminal of the operational amplifier produces an increase in the input voltage U_{12} , which in turn increases the amplifier output voltage U . The increased voltage across the bridge causes the current flowing into the hot-wire sensor to increase, thereby dissipating more energy and raising its temperature back toward the preset value. A constant current anemometer lacks the feedback loop from the amplifier to the bridge circuit.

RESULTS

The results noted below are primarily a review of the raw data captured during the August 23, 1995 balloon launch. The data analysis for turbulence identification is beyond the scope of this text and the interested reader is referred to Charles Leonard's thesis "Investigation of an Alternative Technique for Measuring Turbulence in the Upper Atmosphere" available at Old Dominion University.

Figure 3.5 shows the altitude versus pressure for the standard atmosphere [6] compared with the flight data obtained using the Baratron {Barocel Pressure Transducer, model # 600A-1000T-R12-H21-4, pressure range 1000 Torr} onboard the gondola. It is obviously in good agreement for both magnitude and trend.

From Figure 3.6 one sees that the temperatures experienced during flight were

considerably higher than that for a standard atmosphere. This is not surprising considering the warm summer temperatures at Wallops Flight Facility. Importantly, the proper trend for temperature change with altitude is noted.

Analysis showed that the hot-wire data was not captured. Most likely this resulted from the wire breaking prior to or during the early stages of the launch. Thus, the GPS cannot be compared to the hot-wire for detecting turbulence. Instead, the radar track of the balloon flight provided by NASA Wallops is used as a comparator for the GPS data.

Figure 3.7 compares altitude as a function of time as measured by both the GPS and radar. With the exception of the time when the GPS signal was lost, the results closely track

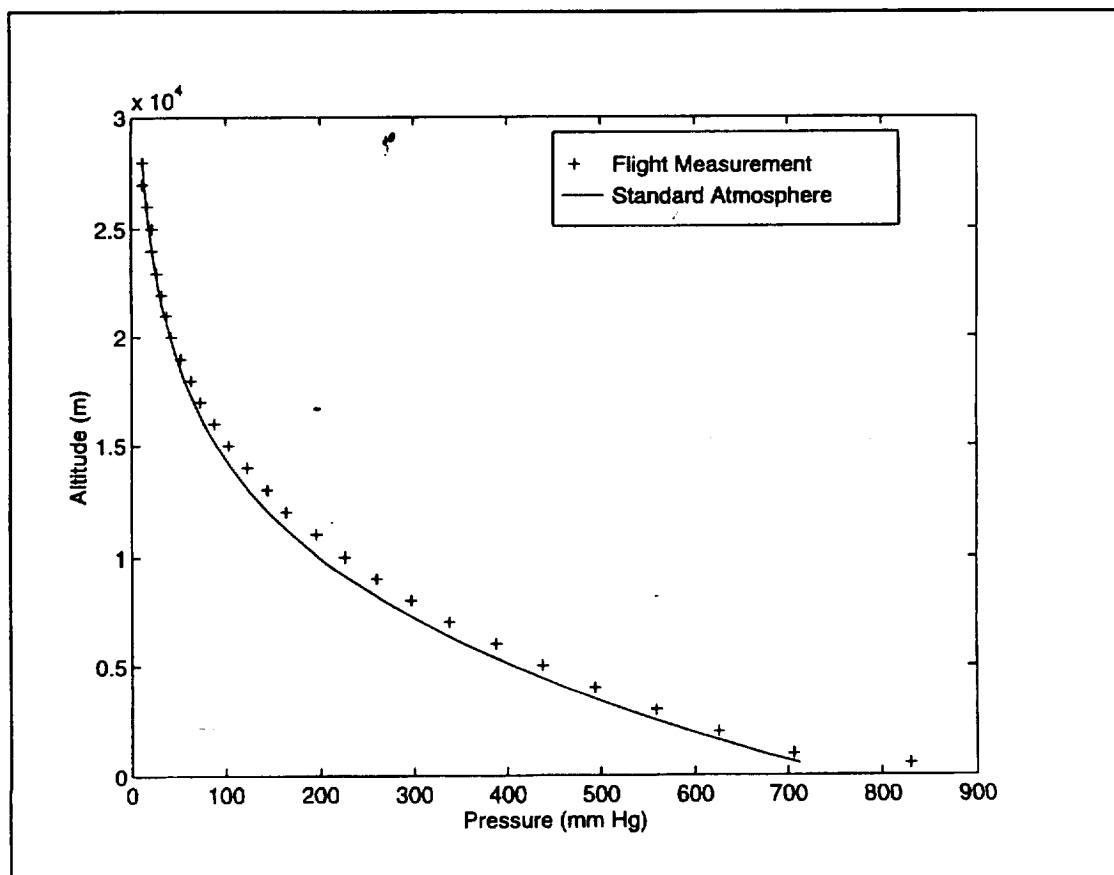

Figure 3.5 Altitude versus Pressure

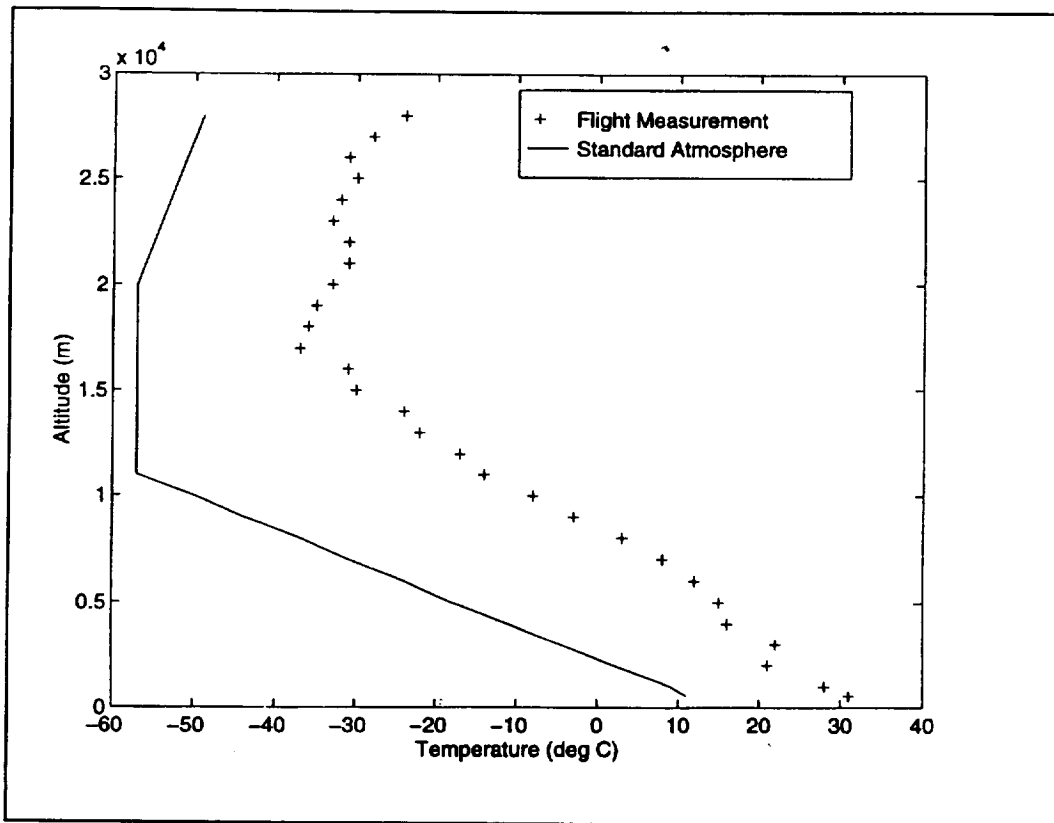

Figure 3.6 Altitude versus Temperature

each other over the entire ascent profile.

The radar and GPS are in excellent agreement comparing latitude and longitude as functions of time (Figures 3.8 and 3.9). Most likely these plots conform more closely since the variation in the horizontal plane occurred more slowly than the vertical change. Additionally, a higher accuracy is generally achieved in horizontal positioning. Reviewing the data it is clear that the GPS system operated within its stated positional accuracies.

RECOMMENDATIONS FOR FUTURE WORK

Overall, the turbulence measuring experiment was a success even though the data

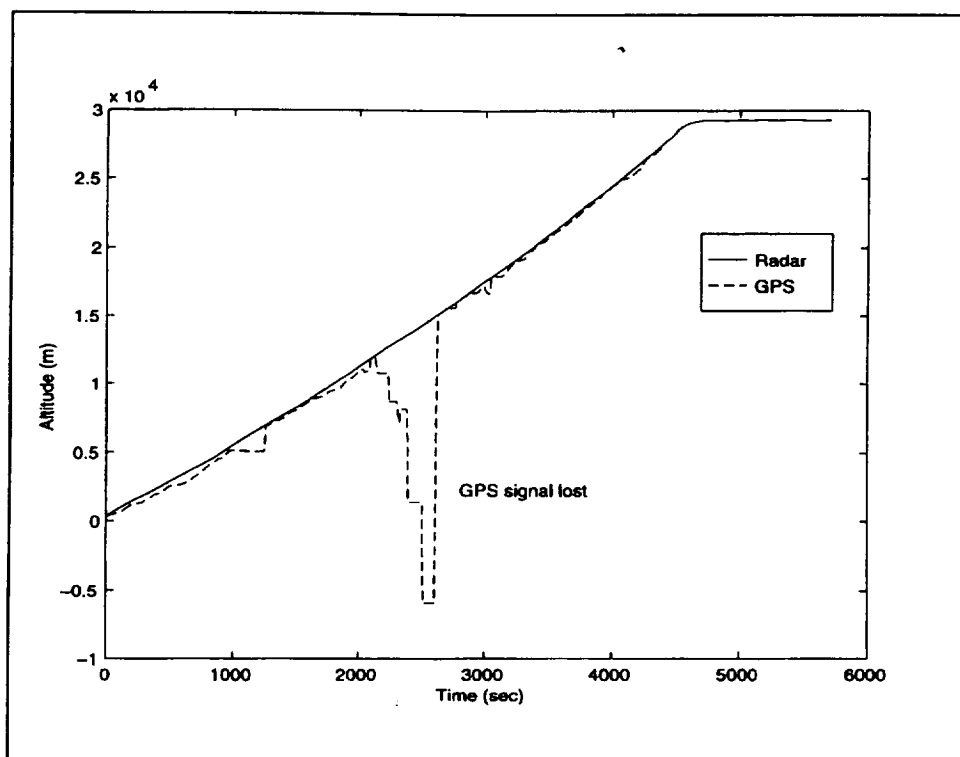

Figure 3.7 Altitude as a function of time versus G.P.S. and Radar

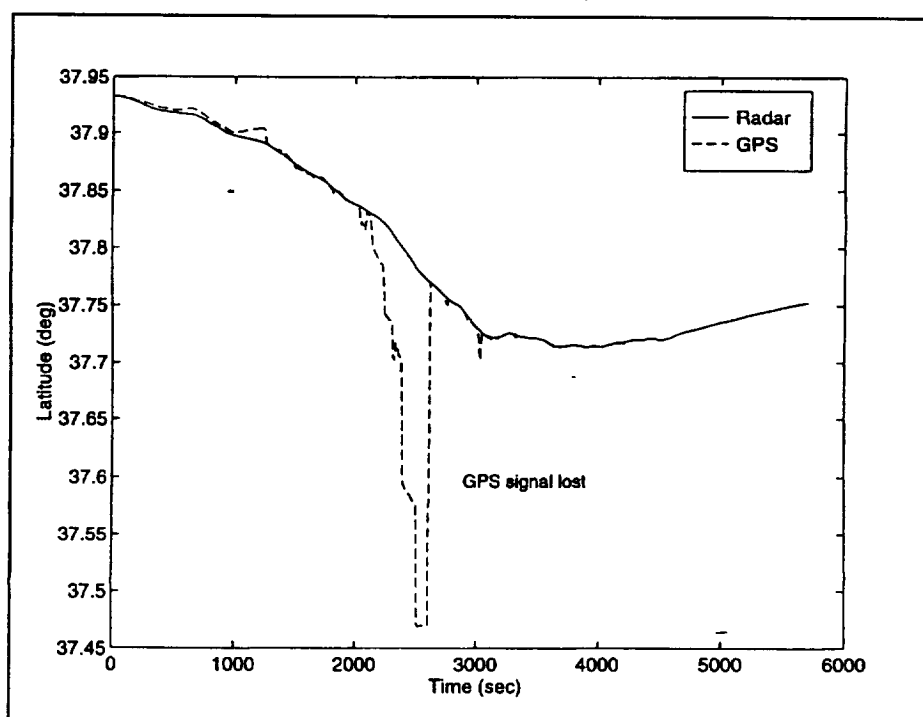

Figure 3.8 G.P.S./Radar Latitude versus time

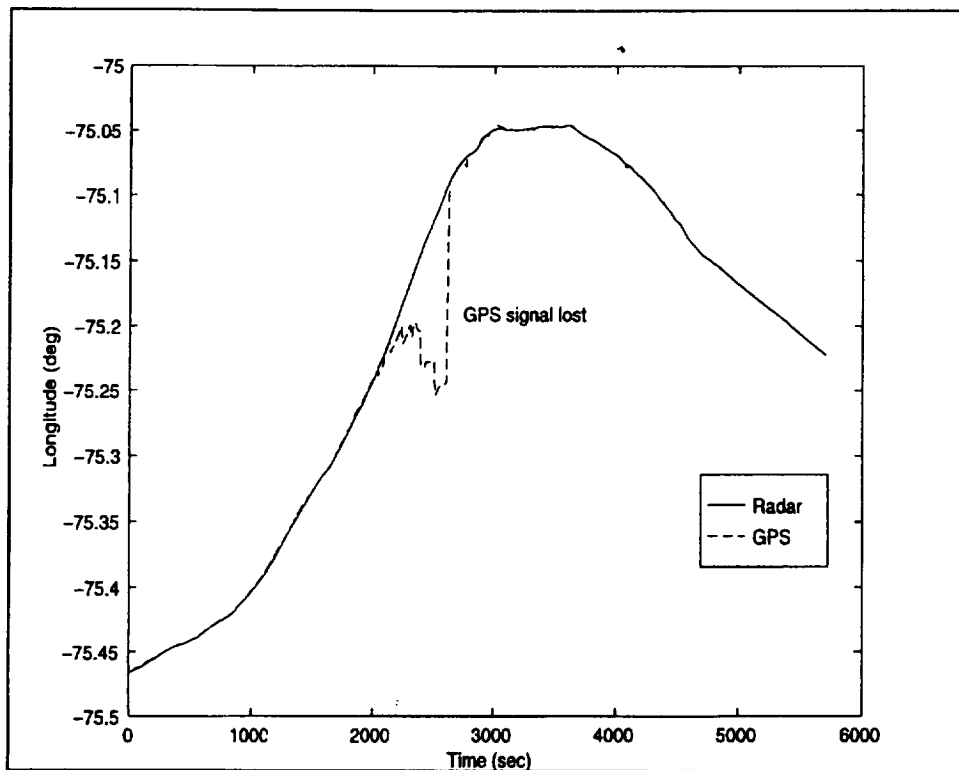

Figure 3.9 G.P.S./Radar Longitude versus time

from the hot-wire anemometer was not captured. The simplest recommendation to improve the experiment is to replace the hot-wire sensor with a hot-film sensor. The increased cost is justified by the greater probability of obtaining data due to increased reliability.

A more complicated recommendation would be modification or replacement of the hot-wire circuit. The particular design used encouraged hot-wire circuit damage following loss of the sensing element. Perhaps a small resistance placed in series with the probe would prevent the overcurrent problem that leads to burnout.

For the project as a whole, there are several suggestions. The most obvious necessity is to plan a schedule and stick to it. This cannot be overemphasized due to the number of people and the expense involved in such an undertaking. Falling behind not only jeopardizes

the mission's success but will take the enjoyment out of the process.

In general, it is desirable for undergraduate students responsible for critical technologies to be enrolled in a class such as a senior project where a letter grade is assigned. This provides the proper impetus for successfully completing the project. If the launch is scheduled to take place during the summer, then the entire project needs to be completed a couple of weeks before spring final exams.

System integration and testing needs to be allotted more time and it needs to be done earlier in the schedule. Fixing hardware and software at the last minute is nerve-wracking and does not reflect well on those involved.

Taking advantage of the expertise provided by NASA from an early stage and keeping them informed of progress can help avoid expensive and time consuming pitfalls while still letting the students learn as they work on the project. This includes thoroughly understanding the launch process and requirements.

Preparing a pre-launch and a post-launch checklist is important. This eliminates the possibility of forgetting something critical to the mission's success. A list of items required at the launch site is helpful. That list should be sufficiently comprehensive to permit adjustment or repair of all system elements. The students should bring all necessary tools for working on the project.

It is very helpful to have all materials relating to the project at the launch and during the meetings with NASA. This includes system schematics, software code, and product information. Keeping all receipts as well as contact names for certain services is helpful to future groups and for post-launch reporting. All testing results should be cataloged as should

the time of launch, the time of balloon termination, the time the balloon landed, and atmospheric variables such as temperature, pressure, etc. Sometimes it isn't apparent what information will be needed for post-flight analysis so recording all the data possible is prudent.

College of William and Mary Atmospheric sampling experiment

Analysis Chamber Characteristics (Figure 3.10)

The analysis chamber is cylindrical with a volume roughly equal to $.01 \text{ m}^3$. A quadrupole mass spectrometer [Dycor model MA100MF] is used to record the mass/charge spectrum of the samples, and an ion gauge measures the total pressure of the chamber. Attached to point C is a leak valve (valve 1) [Varian, model 951-5106]; connected to the leak valve is a stop valve (valve 2) [Nupro, model SS-4H] at the end of which is an adapter that reduces to a screw fitted to the electronic valve [SMC "solenoid valve," model NVZ 110] at the end of the cylinder (this allows easy sample changes). A viton ring at the base of the screw helps to insure that there will be no leaks at this connection. The volume from point C to point B is roughly 60 ml. The chamber is pumped with a cryo pump.

Post-Collection Procedures

On August 24, 1995, the cylinders (eight stainless steel and one aluminum cylinder), were brought to William and Mary after retrieval. The analysis chamber is pumped with valve 1 fully open and valve 2 closed so that space A is evacuated. The cylinders are

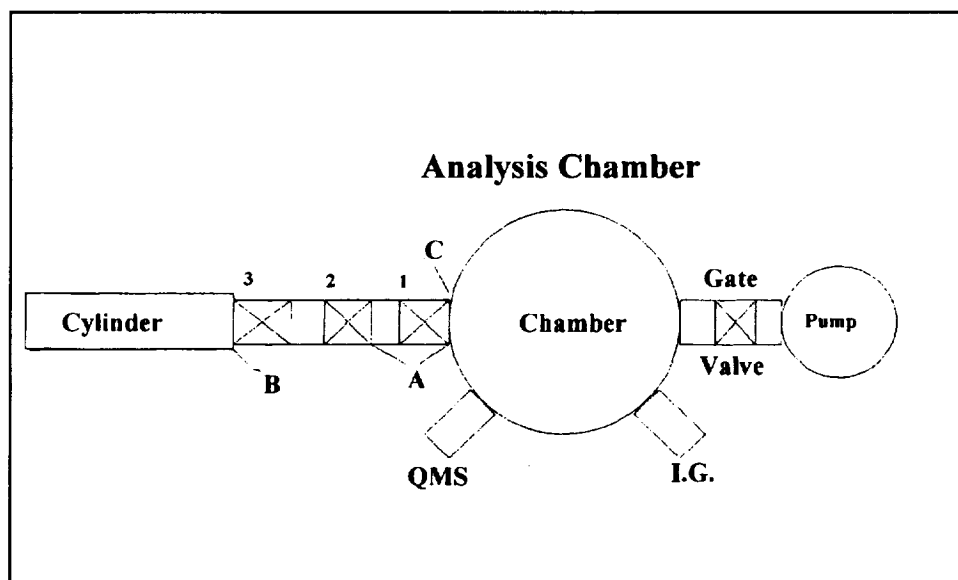

Figure 3.10 Analysis Chamber

attached to the chamber at point B.

Once the cylinder is attached to the analysis chamber, valve 2 is opened, so that the volume up to B is evacuated. The valve 2 is closed and valve 1 adjusted to the desired flow rate (this requires partially closing valve 1). After valve 2 is completely closed, valve 3 is opened and then immediately shut, thus, the volume from valve 2 to point B is filled with sample from the cylinder. Valve 2 is opened allowing sample to flow through the leak valve to the analysis chamber. QMS spectra are recorded along with a chart of total pressure while valve 2 is open. The elapsed time from the launch of the balloon is recorded at the beginning of each mass spectrum throughout the entire project.

The following chart shows the QMS settings for each sequence of runs on Aug. 24

Cylinder	amu/q range	electric mult.	Dwell
aluminum	1-100 50-100	off on	120 ms 1 sec
cylinder 1	1-100 50-100	off on	120 ms 1 sec
cylinder 2	1-100 50-100 50-100	off on on	120 ms 250 ms 1 sec
cylinder 3	1-100 50-100 50-100	off on on	120 ms 250 ms 1 sec
cylinder 4	1-100 50-100	off on	120 ms 1 sec
cylinder 5	1-100 50-100	off on	120 ms .5 sec
cylinder 6	1-100 50-100	off on	120 ms .5 sec
cylinder 7	1-100 50-100 50-100	off on on	120 ms 250 ms .5 sec
cylinder 8	1-100 50-100	off on	120 ms .5 sec
cylinder 9	1-100 50-100	off on	120 ms .5 sec

Cylinder 9 has not been opened since it was evacuated on the day of the balloon launch. This makes cylinder 9 very important for background spectrum, because the stainless steel cylinders are known to outgas at low pressures, and it is necessary to know what portion of a cylinder's spectrum is due to outgassing, otherwise, the magnitude of a sample's contamination due to outgassing will not be known. By looking at the difference

between cylinder 9's spectrum and the chamber's spectrum, we can isolate the gas components of cylinder 9 (it will always be true that a QMS scan shows the composition of the sample and the outgassing of the chamber walls). After doing this several times, the outgassing's time dependence can be calculated and used to extrapolate the composition of each cylinder's outgassing at any time, most importantly, the time at which a cylinder's electronic valve was opened.

The range of QMS parameters represents a balance between better resolution and signal/noise ratio. When the electron multiplier is used to increase the signal/noise ratio, the voltage is set at -800V, corresponding to a gain of 10. The longer the dwell time, the better signal/noise ratio. However, a dwell time of 1 second or .5 seconds for a 1-100 amu/q scan requires a long scan time (> 10 minutes). This is unacceptable, because after roughly eight minutes so much sample has been pumped from the analysis chamber that the QMS can no longer detect the trace amounts remaining. Restricted scans of the 5-100 amu/q range gave greater signal at masses that were undetectable at a lower dwell time, because it is possible to lengthen the dwell time without worrying about running out of sample at the end of a run.

On the second day of testing, August 25, the procedure was as follows: After connecting the cylinder and pumping the space up to point B, valves 1 and 2 are closed. Once again, after making certain that valve 2 is fully closed, valve 3 is opened and then immediately shut. Next, valve 2 is opened and then valve 1 is adjusted to the desired flow. Ten QMS measurements were taken on August 25, one per cylinder. All scans have a range of 1-100 amu/q with the electron multiplier off and a dwell time of 120 msec.

By day six, greater experience with the QMS allowed the following modifications that

greatly increased the sensitivity and signal/noise ratio. The samples per amu scanned by the QMS are changed from 8 samples/amu (the value for all previous measurements) to 15, this significantly improves the resolution. The emission current of the QMS's filament was increased from .1 mA to 1 mA. By increasing the emission current, more of the sample-gas is ionized which increases the sensitivity of the QMS. This, combined with the electron multiplier, increases the signal/noise ratio.

The procedure on day six is very similar to that of day two, except that the source for background measurements has changed. Previously, cylinder 9 was used as background, but the threaded port on the electronic valve of cylinder 9 had become damaged and could not make a reliable seal. Fortunately, enough samples from cylinder 9 were already taken to calculate the cylinder's outgassing, so cylinder 9 was no longer essential. From day six on, the background is measured by a QMS scan of the chamber after the cylinder has been attached to the chamber. The benefit of running the RGA after each cylinder is attached was that it told us if the seal at point B was leaking.

On day seven, August 31, early analysis of the data collected previously showed a lack of information for masses greater than 50 amu/q. The signal/noise ratio is further improved by increasing the emission to 10 mA and doubling the dwell to 250 msec. After each cylinder is attached, a QMS scan is taken of the analysis chamber for 50-100 amu/q. Then, following the procedures from August 30, sample is bled into the chamber and the QMS scans a domain of 50-75 amu/q. After the QMS is finished, valves 1 and 2 are opened and the entire chamber is pumped. Once the chamber has reached base pressure, the procedures for flowing sample are followed again and a scan from 75-100 amu/q is recorded.

Breaking the scans into two halves gives the RGA a chance to record what might be a very small amount of the heavier gasses before the cryo pump can remove them from the system. Since the cryogenic pumping speed, for molecular flow conditions, is inversely proportional to the mass of the molecule ($S_0 = (kT/2pM)^{1/2} * 10^{-3}$), the larger molecules should be present in the chamber throughout the length of the RGA scan (3.5 minutes in this case).

On September 5th and 7th, under suspicion that some molecules from the sample may have condensed to the sides of the cylinder after such a long period of time, the cylinders are heated, using heating tape, to 80-93 C. The RGA scan is set 1-100 amu/q, dwell is 120 msec, sample/amu is 13, and the emission is 1 mA. Procedures for flowing sample-gas are the same as on August 30. A chart below shows the temperatures for each cylinder.

Cylinder	Temperature °C
1	93
2	84
3	87
4	90
5	83
6	86
7	84
8	80

Cylinder 1 through 4 were measured on September 5th and 5 through 8 were measured on the September 7th.

Results

Enclosed, see Figure 3.11, is our calibrated data Of S02 as a percentage of the total sample gas. Notice that the amount Of S02 in our control cylinder (cylinder 9) exceeds all but two of the other cylinders; and no cylinder contains enough S02 compared to cylinder 9 to make us confident that the S02 component comes from the atmosphere. There are three possible explanations for the appearance Of S02:

1. The quadrupole is lying. The possibility exists that the QMS has a systematic error. But since our spectra show reasonable amounts of air and water vapor components, with the expected cracking patterns, the probability of systematic error is small.
2. The cylinders (or the analysis chamber) were improperly cleaned, leaving trace amounts Of S02 on the cylinder (or chamber) walls. There was a procedure for cleaning the cylinders which involved baking out the cylinders several time before launch, but it is not known how effective that procedure was. Furthermore, the chamber was not baked out immediately before the samples were measured. It could be that S02 already existed as a contaminate in the chamber. But if the observed S02 is the result of out gassing from the chamber walls, then why is there so much fluctuation? One would expect steadier out gassing.
3. There was S02 in the first cylinders from the atmosphere, but portions of those gases absorbed onto the chamber walls, contaminating the system and causing S02 to appear in

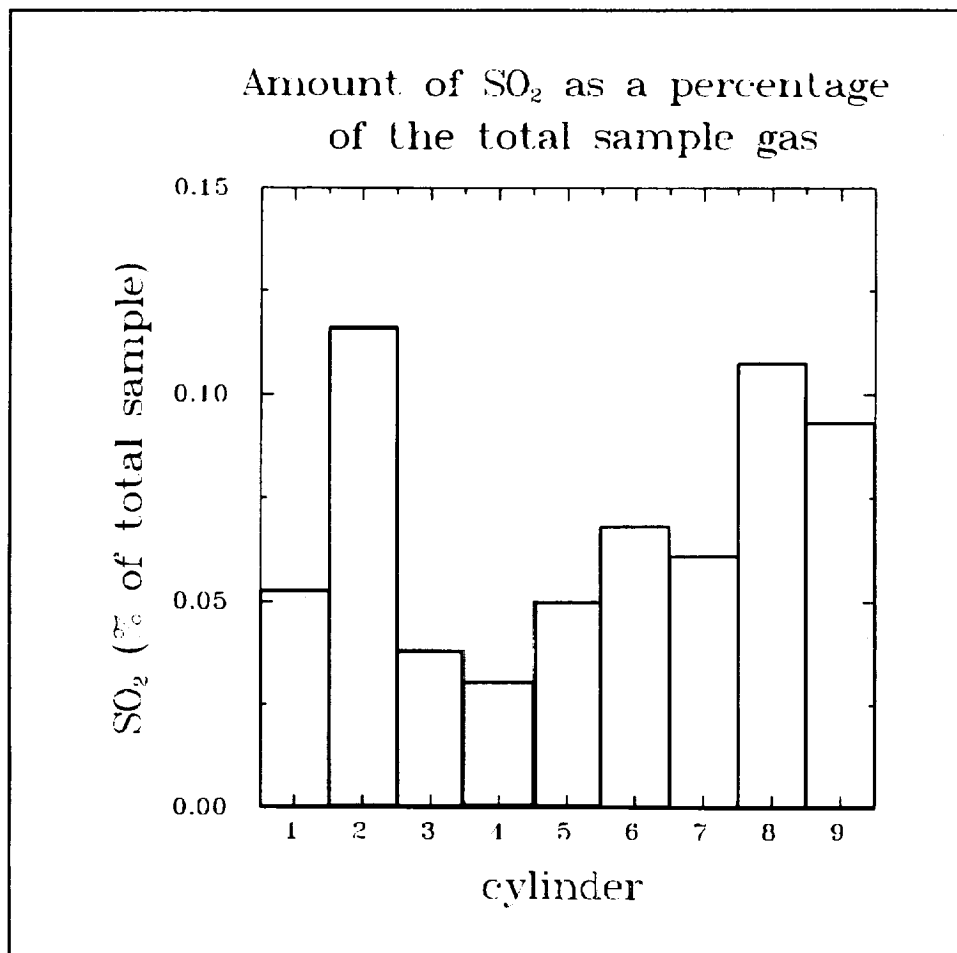

Figure 3.11 Percentage of SO₂ found in cylinder

every run. It is known that SO₂ is corrosive, but it is impossible to be certain, without independent confirmation, as to whether or not the SO₂ measured in cylinders one and two come from the atmosphere or from contamination.

Improvements

The use of a cryo pump for this project was not optimal. The fast pumping rate of the cryopumps and the mass-dependence of their pumping speed makes recording and analysis of the data more difficult.

There are many features of this project which could be improved. The experience gained in producing precise RGA measurements (i.e. greater signal/noise ratio and resolution) will help in future work. In this experiment, time was wasted on scans with poor resolution. Consultations with experts on atmospheric science will help to understand wall-effects on sampled gases. Transient, unstable species cannot be detected in this way at all. Many species may catalytically interconvert on the walls as time progresses.

A better pre-flight data analysis plan would have yielded results more quickly. Future flights may include an on-board mass spectrometer or tuned device designed specifically to monitor H_xSO_y species ($x=0,1,2$; $y=2,3$).

Hampton University Water Vapor Density Experiment

The Hampton University Water Vapor Density Experiment was designed to measure the density of water vapor molecules as a function of altitude during the ascent and descent of the balloon. The system consisted of a diode laser, two detectors, a temperature monitor and an optical cavity to provide an extended optical path length. The system was optically aligned in the laboratory prior to transporting it to the Wallops Island launch site. Final alignment and calibration of the system at the launch site was hindered by lack of a facility where the water vapor density could be controlled. During the balloon flight the system performed as expected but analysis of the recorded data was not possible due to the long time scale to which the recorder was set. The recorder data could only be read out graphically as digital recorders would have pushed the experiment beyond the weight limit. The long

time scale to which the recorder was set was required prior to launch due to the large uncertainty in the actual launch time. The recorder could be set to record data over a specified time and a time scale corresponding to the actual Flight time would have produced useful data. The longer time scale that was actually used compressed the graphical data into a narrow part of the graph (i.e. a narrow time segment). This compression made it impossible to compare measurements at a given time due to the large error in the time measurement. This was further complicated by the small difference in the two signals (i.e. the difference in the intensity of the absorbed and unabsorbed beams was very small).

In spite of the Fact that the recorded data was not useful, a great deal was learned from the experiment and we are now confident that an experiment could be designed that would perform as originally expected. Several changes should be made. These include: (1) a laser operating in the visible portion of the spectrum so that alignment of the system would be much easier, (2) record the data digitally so that a direct comparison between the two beams could be made and (3) design a better cavity using highly-reflective mirrors which would allow a much longer absorption path length to increase the difference in the two signals.

IV. Recommendations

In preparation for future flights, recommendations are presented here to help reduce problems and concerns experienced during this first balloon flight. Although some of the items presented here are redundant, it was felt necessary to address each item in detail to express the importance of each.

At the beginning of the project, a schedule was created based on time constraints allotted for the project. During the course of the schedule, certain unanticipated problems occurred causing delays. Additionally, delays from individual teams at times caused additional scheduling conflicts. To help alleviate this concern for future flights, incorporating into the schedule downtime for delays should be done and strong emphasis on meeting scheduling dates needs to be done.

Having teams from different institutes can lead to problems on taking requests seriously. Throughout the project request were made by the Project Manager to all teams at various times either requesting specific information of specific items with posted due dates. Very rarely were these request met on time, if at all. So to help alleviate this problem in future flights, some form of follow up should be enforced, either project grade, faculty discipline, or stipend reduction, for those students who don't meet the requirements or requests.

Throughout the Payload project, internal documentation was very poor. The project manager was not kept up to date on status of project and weekly reports documenting progress. It is important that detailed aspects of the Payload design be documented

throughout the project and finalized as the designs are. This is necessary for any problems that arise calling for trouble shooting. Therefore, detailed documentation should be required from all teams throughout the project relating to the design and programming incorporated by each as it is done and modified.

A specific area addressed in the schedule is related to integration of Payload components. During this flight, integration of the data acquisition computer with the experiments was not completed until the day of the first launch attempt. It was at this time problems were realized between the components as well as within the computer itself. To help prevent this from occurring again, emphasis on complete integration tests in situations it expects to operate under need to be performed and this time should be considered when developing the schedule.

In finishing up the project, it was necessary to go past the end of the semester. Little assistance was obtained from the students at this time so the final work was completed by a very few. Students selected for working in future should be made aware when taking on this project it is until completion.

V. Footnotes

- 1) Turbulence in the Free Atmosphere, Vinnichenko, Pinus, Shmeter, and Shur, p.1.
- 2) THE ATMOSPHERIC BOUNDARY LAYER FOR ENGINEERS, Ram S. Azad, Kluwer Academic Publishers, Boston, 1993, p.34.
- 3) Simpson, Theodore R. 'A Second Revolution for Air Navigation and Landing' Aerospace America, August 1995, p.19
- 4) FLUID MECHANICS MEASUREMENTS, Richard J. Goldstein, article THERMAL ANEMOMETERS by Peter Freymuth and Leroy M. Fingerson Hemisphere Publishing, New York, 1983.
- 5) A CONSTANT TEMPERATURE HOT-WIRE ANEMOMETER, Miller, I.S., Shah, D.A., Antonia, R.A., Journal of Physics E, Vol 20, 1987, p.311-314
- 6) U.S. Standard Atmosphere, 1962. U.S. Government Printing Office, Washington D.C.,1962.

VI. Acronym Definitions

V_{ps} - Virginia Space Grant Consortium Upper Atmospheric Payload Balloon System

MRR - Mission Readiness Review

WFF - Wallops Flight Facility

NSBF - National Scientific Balloon Facility

GPS - Global Positioning System

VII. Appendix A : Schedule

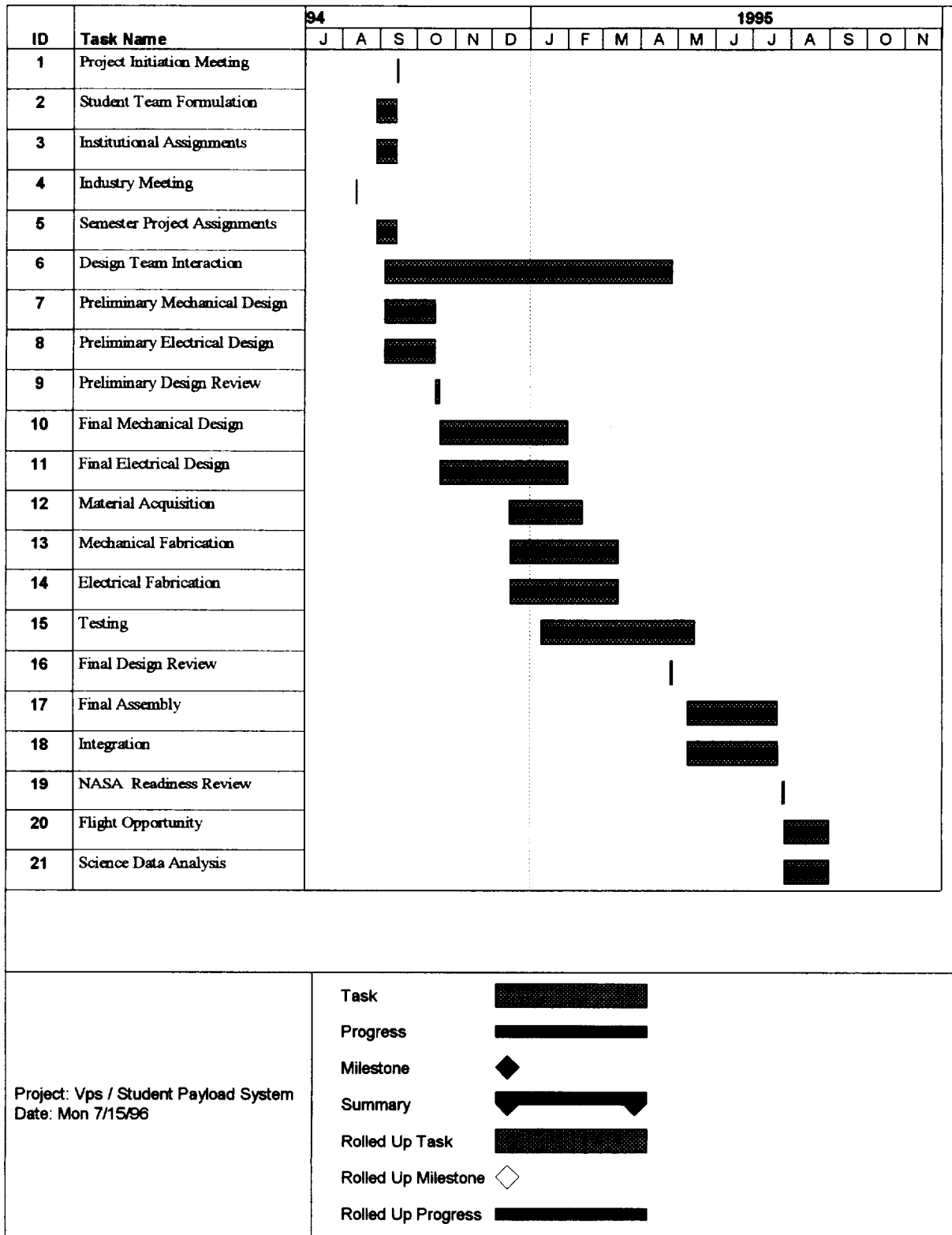

VII. Appendix B: Final Design Review Action Items

Below is a combination of all comments / action items received. Each team's comments have been put in individual sections and names of commenting individuals, where names were given, separate each section. In accordance with the schedule time remaining, I have put deadlines on action items for when they should be resolved, ABSOLUTELY! Where items have no specific date, refer to the General Survey Time Line below.

General Summary Time Line

May 15, 1995 Material Acquisition Deadline

May 19, 1995 Hardware review meeting

May 31, 1995 Testing completion deadline

June 15, 1995 Integration and Assembly deadline

GENERAL COMMENTS / ACTION ITEMS

Marty Kaszubowski (Space Tec)

- * Need a better overall definition of the science requirements
 - criteria for success of the mission
 - data parameters
 - data rates
 - Balloon operational capabilities

Feedback from Doug Bell during meeting

Lot of work over next two months
 Mission Readiness review after all assembled
 NASTRAN data submitted to Doug

From Bryan Marz

June 15 drop dead for resolving all issues
 May 19 - Hardware Design Review

ACTION ITEMS / COMMENTS

HU Water Density Experiment

Dr. Ash (ODU)

- *Status of parts and construction of reflecting cavity (completion date needed)
- *Solar radiation problem--what problem? Requirements?
- *Dimensional stability of reflector cavity
- *Data acquisition and storage system (data logger-details?) MAY 19, 1995
 - *Data storage medium
 - *Sampling rate
 - *Sample size
 - *Output for ODU system
 - *Power supply and endurance
- *Laser temperature control (also power consumption)
- *Final delivery of experiment MAY 19,1995

R.H. Bradford (NASA)

- * How often will the exchange of air within the confines of the water vapor experiment so that useful data can be taken.
- * How far is the water vapor experiment away from the balloon to prevent contamination and water from condensation on the balloon from entering the experiment

Ed Fasanella (Lockheed)

- * HU experiment - If there is concern over solar energy, a reflective cover such as silvered Mylar should take care of most of the problem. Concern about condensation on the mirrors and the effects of temp on the experiment

Unknown comment originator(s)

- * Materials (detectors, aluminum) orders delayed MAY 15, 1995
- * Solar radiation impact / modifications due to top tray placement MAY 19,1995
- * Need to determine insulation materials May 15, 1995
- * Need to consider possible problem of condensation on mirrors MAY 31,1995

W&M Experiment

Dr. Ash (ODU)

- *Back ordered bottle problem MAY 15, 1995
- *"Dummy" sample bottle specs. and purpose
- *Detailed description of experiment--specifying data acquisition and control requirements, including specific archiving data specs. MAY 19,1995
- *Impact testing of final configuration MAY 31,1995
- *Problem with bottle necks and shelf height
- *Need to "point" bottles into the wind to minimize contamination
- *Sample during descent looks very questionable, avoid it
- *How will bottles be protected from atmospheric pressure after landing?

Ed Fasanella (Lockheed)

- * W&M experiment - The system needs to be tested to determine the characteristics of the valve due to temperature, moisture, vacuum, etc. MAY 31,1995

Do the specifications for the valve cover the entire range of conditions that could occur during the balloon flight ?

What is the size of the orifice, and how long will it require to take a sample? MAY 19,1995

Will an impact of 15-25 G's effect the valve or allow it to momentarily open?
MAY 31,1995

Brent Justus (W&M) All out gassing questions resolved by MAY 31, 1995

- * out gassing of PVC shrink wrap on batteries
- * Adhesive out gassing
- * Tether line out gassing
- * shelf lip height
- * Does W&M have the option of having the whole level ?

Unknown comment originator(s)

- * Need to resolve whether line (coating) is out gassing - W&M to evaluate
MAY 31, 1995
- * need to resolve altitude data issues MAY 19,1995

ODU ECE

Dr. Ash (ODU)

*Uneasy feeling about software

More detail needed--Need specs. from ECE to each expt. MAY 19,1995

Essential to demonstrate and test all software

Use dummy signal sources to simulate complete cycle

*Power supplies must be subjected to realistic testing w/o running batteries down

Shorts and back charging are serious concerns

Shrink wrap is likely to contain chlorine compounds--avoid

Crash landing protection is a critical issue--can any kind of battery disconnects be built into the "cut down"? MAY 19,1995

Consider cutting the wires to W&M system to avoid accidental valve actions during descent

Marty Kaszubowski (Space Tec)

* Need to define the specific requirements for computer control / monitoring of equipment

- Interfaces with each payload MAY 19,1995

*Need a software test-plan (based on requirements defined according to the nominal and off-nominal operational scenario) MAY 19,1995

Dr. Sebastian Bawab (ODU)

* detailed flowchart of ECE including deadline of procurement MAY 19,1995

Warren Blanco (ODU)

* out gassing of shrink wrap MAY 15,1995

* construction of casing for battery pack if shrink sleeve can't be used MAY 19,1995

Unknown comment originator(s)

* All control signals, parameters, data channels must be documented and identified. Each experimenter must identify now !

- must develop interface control MAY 19,1995

Data Acquisition

- * Test GPS with program MAY 31,1995
- * assume can actually modify code (per Bob Ash discussion)
Document program MAY 19,1995
- * Need to resolve interface with DAS / program and experiment MAY 19,1995
- * Need detailed testing plan for DAS - from Marty Kaszubowski - Experience has shown this to be critical MAY 19,1995

Power

- * What happens if can't use shrink wrap because of out gassing ?
- need info on out gassing and resolve wrapping material. Look at other types of shrink sleeves MAY 15,1995
- * Need to determine impacts on W&M air sampling experiment
-Optimize pointing of sample bottles
- * Determine that shorts on impact will not affect payload MAY 19,1995
- * Testing using same battery pack. Buy one more. MAY 15,1995
- * Consider run wires with plug attachment so can pull when/as parachute deploys
- * Consider descent profile of small balloon. Impact velocity is 19 ft/s

Instrumentation

- * Testing of switch and valves / connections from W&M experiment
(Civarath Tum ODU) MAY 19,1995
- * Need parts inventory for DAS and Power. What remains to be Purchased ?
MAY 15,1995

All purchases must be made before MAY 15,1995 and should be presented on MAY 19,1995

ODU ME

Dr. Ash (ODU)

- *Track down Ethafoam as a non-contaminating insulation (rather than Styrofoam)
MAY 19,1995
- *Send cardboard (bonding layer) sample to W&M for analysis MAY 19,1995
- *Gondola lines need to be investigated by W&M for contamination--soak in
water to remove coating
- *Probably need to get solar shielding requirements from HU
- *A whole set of insulation requirements must be addressed during
payload integration MAY 31,1995
- *Reel system is not ready and needs more work MAY 31,1995
Brake system--static and dynamic friction--unreliable
Encoder/revolution counter lacking details--need to get to
an ECE acceptable interface
- *Need to get NASTRAN data to Wallops ASAP MAY 15,1995

R.H. Bradford (NASA)

- * Mount all important components within the confines of the payload assembly
to prevent shear or breakage of components
- * The structure needs to have internal standoffs (threaded rod) through the
entire layers to increase survivability at parachute inflation and impact.
MAY 19,1995

Ed Fasanella (Lockheed)

- * Structure and Impact - Reiterate that the initial acceleration spike probably
is not too important since it is of a very short (few milliseconds)
duration. In crash analysis, we often filter the crash acceleration pulse
using a 60 or 100 Hertz low-pass filter. Often the high frequencies on top
of the basic deceleration pulse are just elastic vibrations that would occur
if one were to excite the structure.

Also, the stress analysis was done well. However, even if the design stress is
exceed for the impact, a little plastic deformation is not a bad thing as long
as there is not a structural separation-type failure. Note that a 15g static
load is usually much worse than a dynamic 15g load for a fraction of a second.
In a dynamic crash of short duration, the structure does not have time to come
to steady state solution and will not deflect as far as predicted statically.

Dr. Sebastian Bawab (ODU)

- * Battery package
- * winch mounting MAY 19,1995
- * hot-wire anemometer deployment MAY 31, 1995
- * stiffening the payload for structural integrity
- * valve position to be addressed MAY 31,1995

Unknown comment originator(s)

Structure Design

- * weights of eye bolts and fasteners MAY 19,1995
- * consider stand offs or use of styrofoam for impact. (dead center if possible)
 Need to consider HU optical path
 must consider out gassing of styrofoam. Wallops recommends ethafoam
 (Doug Bell to provide source)
 consider how ethafoam picks up moisture
- * consider options for raising W&M cylinders on structure. Perhaps flat sheet support covering whole area to avoid stress concentration
- * consider how want structure to impact MAY 15,1995
 - 10 g vertical load
 - 5 g 45 degree side load at the suspension point for parachute shock
 (ring and rope)
- * consider parachute drag on ground so don't have cylinders sticking out.
 Consider tubing that can be broken for protection (Maybe aluminum heavy duty oven foil)

Impact Analysis

- * Must determine if spike from tests is truly physical
- * Consider problems of moisture absorption by cardboard (per Wallops probably not a problem -also can't fly in rain)

Interface mounting

- * need to determine center of gravity MAY 31,1995
- * need to provide signal for servo motor to Dr. Gerdin MAY 19,1995
- * consider suspending hot wire below gondola at launch

- * will provide samples of adhesive to Brent Justus so out gassing can be determined MAY 19,1995
- * How will determine at end of line ? Need to determine final resolution. How to avoid yo-yo effect. MAY 31,1995

ODU AE

Dr. Ash (ODU)

- *Safety and payload release design MAY 31,1995
- *Detailed launch to crash landing scenario required--with specific control and output data acquisition signal requirements
- *Wallops requirement for cutting down the hot wire
- *Sequence of FFT and raw data--not parallel--required
- *Telemetry between hot wire and gondola must be tied down and built.
MAY 31,1995

SERIOUS PROBLEMS REMAIN BETWEEN THE EXPERIMENTS AND THE DATA ACQUISITION AND CONTROL INTERFACE.

Marty Kaszubowski (Space Tec)

- * The deployment of the anemometer seems very ambitious. Need to understand the dynamic effects of wind gusts during deployment
 - 1) on the tether
 - 2) on the main box
 - 3) on the anemometer payload

R.H. Bradford (NASA)

- * Hot Wire anemometer - real problem with reel down and shutdown of secondary device
 - Finding such a small package could be a real problem- Needs to be very visual.

Ed Fasanella (Lockheed)

- * Hot-wire experiment - concerned with the long tether, jamming of the spool, tangling, etc. The dynamics of tethered objects are complex and many failure models can occur.

Concerned with the extreme air temperature variations that will occur during

the flight, and how variations will effect the measured velocity. When hot wire probes are used, they are usually calibrated at some ambient temperature. Since the temperature of the air is changing, the calibration will change. In other words, the velocity will not be correct unless both density of air (function of temperature) and velocity are both considered in the calibration.

Unknown comment originator(s)

- * control signal to prevent hot-wire system from being deployed or to cut down Wallops
MAY 31, 1995
- * Be sure all FAA problems resolved with final design
- * control signal for actuation
- * Wallops required proof : MAY 31, 1995
 - reel working (test in chamber)
 - actuation signal

VII. Appendix C : Tentative Schedule Form

If each team leader will distribute a copy of this questionnaire for all team and faculty members. This will help me determine the best times for flight launch opportunity this summer and have a way of contacting all participants if any questions arise.

Name: _____ University: _____

Major: _____ Graduation Date: _____

Project Activity: _____

Summer Address: _____ Summer Telephone Number, other than school: _____

City: _____

Actual Address, if known Permanent Address: _____

Permanent Telephone Number: _____

Please indicate where you will be during the following weeks, i.e. summer school, vacation, job, etc. Then indicate the weeks that you are most likely to be available for balloon activities, by circling each week when you think you will be available.

	Monday	Tues.	Wed.	Thurs.	Fri.
JUNE				1	2
	5	6	7	8	9
	12*	13*	14*	15*	16*
	19	20	21	22	23
	26	27	28	29	30
*Tentative Week for NASA LaRC Undergraduate Design Conference					
WE WILL NOT PLAN TO MEET DURING THE WEEK OF JULY 4					
JULY	10	11	12	13	14
	17	18	19	20	21
	24	25	26	27	28
	31				
AUGUST		1	2	3	4
	7	8	9	10	11
	14	15	16	17	18
	21	22	23	24	25

PLEASE RETURN THIS TO YOUR FACULTY ADVISOR IMMEDIATELY. MAKE A COPY OF THIS FOR YOURSELF, AND IF YOUR PLANS CHANGE, PLEASE NOTIFY US AS SOON AS YOUR NEW PLANS ARE KNOWN. (IT'S BETTER TO HAVE AN APPROXIMATE IDEA OF YOUR AVAILABILITY THAN TO WAIT UNTIL YOU HAVE TIED DOWN ALL OF THE DETAILS FOR YOUR SUMMER. IF YOU DO NOT LIVE IN THE AREA, AND KNOW THAT YOU WILL NOT BE ABLE TO PARTICIPATE IN ANY OF THE BALLOON FLIGHT ACTIVITIES THIS SUMMER, PLEASE INDICATE THAT SITUATION ABOVE. THANK YOU FOR HELPING MAKE THIS PROJECT A SUCCESS SO FAR-NOW, IT IS TIME FOR THE REALLY EXCITING PART OF THE PROJECT TO BEGIN!)

VII. Appendix D Launch Checklist :

1. Verify system working at school
2. Arrive at Wallops : Check in
3. calibrate HU laser
4. install W&M canisters and run /confirm wiring
5. hook up monitor keyboard and dummy probes
6. connect power to systems and canisters and laser (3 batteries)
7. confirm voltages for 7 channels and see if offset present
8. disconnect power
9. take to hanger
10. support by cables
11. attach boom
12. finish insulating lower section
13. install Mylar to top and three sides
14. WAIT
15. carry out to launch area
16. bring power source to power monitor
17. install x-probes and check continuity
18. connect boom in place of dummy probes
19. power system up as ready for launch
20. confirm with monitor all systems working checking voltages
21. leave system running approx 30 min before desired launch to get GPS lock
22. once lock confirmed disconnect monitor keyboard
23. seal up CPU
24. finish attaching mylar
25. at this point no further contact made with payload wait for balloon to be filled and launched only concern now if long time duration and aborted launch BATTERY life time may not be suffice for another launch attempt.

VII. Appendix E Fortran 518 Code

Program Payload 518

```

c
c   Written by : Bryan Edward Marz, Project Manager
c   Date : November 1995
c   For the Virginia Student Upper-Atmospheric Payload System
c
c   This program was written and designed to read in and convert
c   output data form the 518 payload data acquisition board
c
  real x1,x2,x3,x4,x5,x6,x7,x8,x9,x10,x11,x12,x13,x14,x15,
  + x16,x17,ch0,ch1,ch2,ch3,ch4,ch5,ch6,ch7

c   open files for converting 518 computer data
c   518_dat.1   is output file from payload
c   518_dat.out  will be output / converted results
c
  Open (6,file='e:\data\518_dat.1')
  Open (7,file='e:\data\518_dat.out')
c
10  read(6,*) x1,x2,x3,x4,x5,x6,x7,x8,x9,x10,x11,x12,x13,x14,x15,
  + x16,x17
c
  if (x1.eq.500.and.x16.eq.70.and.x17.eq.132) goto 1000
c values for quitting program were found by searching program for
c end of pertinent data ( this can either be replaced or removed
c for future data collections as theses values are run specific )
c
cc  write(*,*)x1,x2,x3,x4,x5,x6,x7,x8,x9,x10,x11,x12,x13,x14,x15,
cc  + x16,x17
  time=x1/500.

c channel 0 no pertinence so nothing needs to be done
  call voltage(x2,x3,ch0)
  chan0=ch0
c
c channel 3 temperature reference voltage
  call voltage(x8,x9,ch3)
  chan3=ch3
c channel 1 atmospheric temperature voltage
  call voltage(x4,x5,ch1)
  chan1 = 130.011839-(ch1/ch3)*(1/.005068)
c channel 2 environment temperature voltage
  call voltage(x6,x7,ch2)
c
c   Channel 2 thermister was damaged and repaired before flight
c   and it was noticed that voltage readings were off, so trying
c   to incorporate offset to see if values could be made relevant
c
  tmep=tmep+1
  if (tmep.eq.1) tempoffset=ch1
  if ( tmep.gt.1. and.tmep.le. 30 ) then
  tempoffset=((tempoffset*(tmep-1))+ch1)/tmep
  endif
  deltatmp=tempoffset-ch2

```

```

chan2 = 130.011839 - ((ch2 + deltamp) / ch3) * (1 / .005068)
c
c channel 4 detector voltage
c the 3.167 was determined through bench tests run before installation
c
call voltage(x10,x11,ch4)
chan4 = ch4 * 3.167
c channel 5 detector voltage
c the 3.167 was determined through bench tests run before installation
c
call voltage(x12,x13,ch5)
chan5 = ch5 * 3.167
c
c channel 6 baratron pressure reading
call voltage(x14,x15,ch6)
chan6 = ch6 * 100
c
c channel 7 no pertinence
call voltage(x16,x17,ch7)
chan7 = ch7

cc write(*,*) ' '
12 format(f8.1,5f12.5)
write(7,12) time,chan1,chan2,chan4,chan5,chan6
goto 10
1000 end

-----
c
subroutine voltage(xx,yy,zv)
real xx,yy,zv,xx1,yy1,tempint
integer msb,lsb
if (xx.lt.127) goto 100
c if (xx.le.127) goto 100
goto 200
c
c positive voltages
c
100 msb = xx / 16
xx1 = msb
yy1 = (xx / 16) - xx1
tempint = yy + xx1 * 16 ** 3 + yy1 * 16 ** 2
zv = tempint * 6.553 / 32767
return
c
c negative voltages
c
200 msb = 255 - xx
lsb = 256 - yy
xx1 = msb
yy1 = lsb
msb = xx1 / 16
xx1 = msb
yy1 = (xx / 16) - xx1
tempint = yy + xx1 * 16 ** 3 + yy1 * 16 ** 2
zv = -tempint * 6.553 / 32767
return
end

```

VII. Appendix F : Assembly Drawing

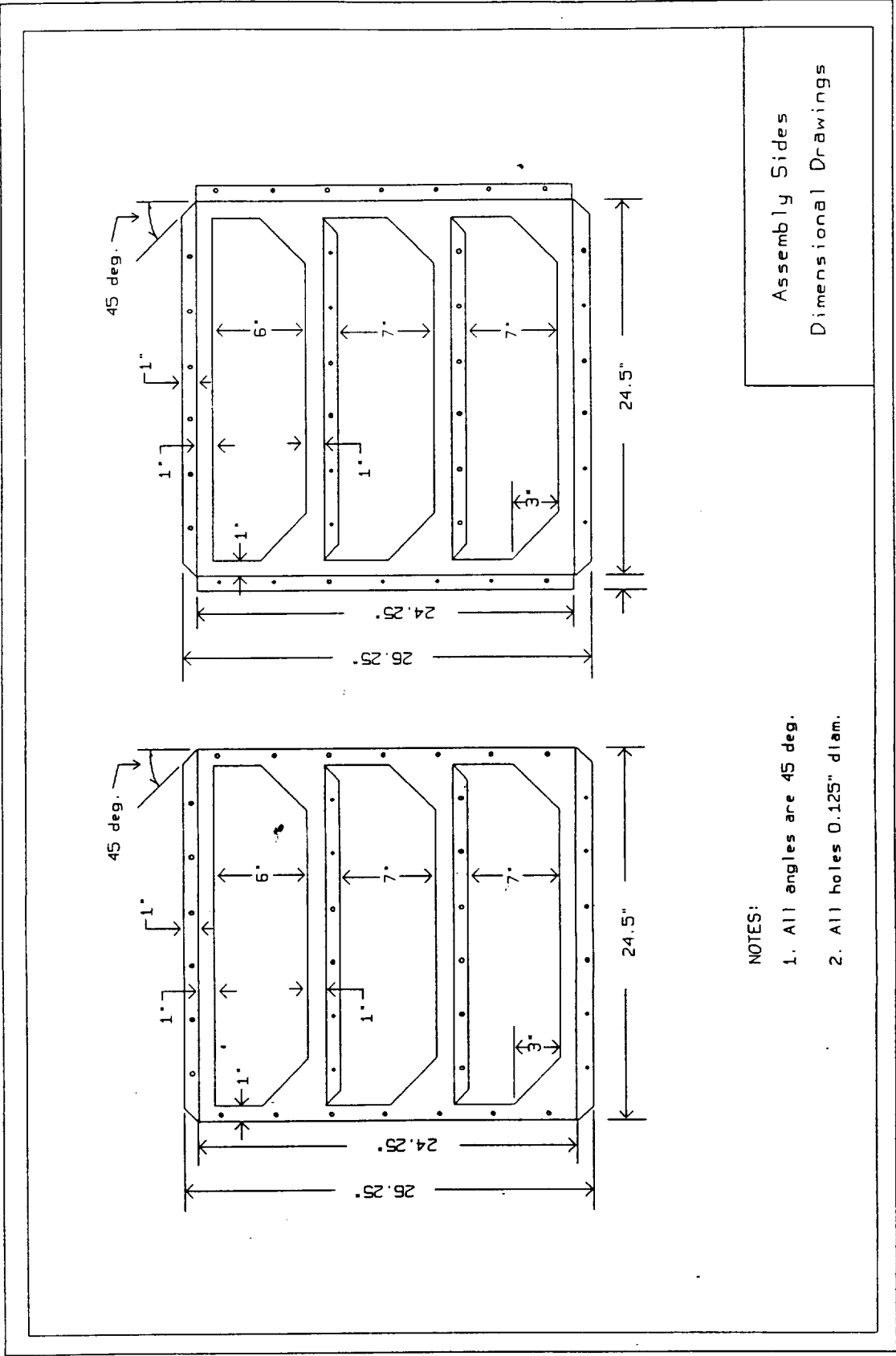

- NOTES:
1. All angles are 45 deg.
 2. All holes 0.125" diam.

Assembly Sides
Dimensional Drawings

3-D Isometric
(Assembly only)

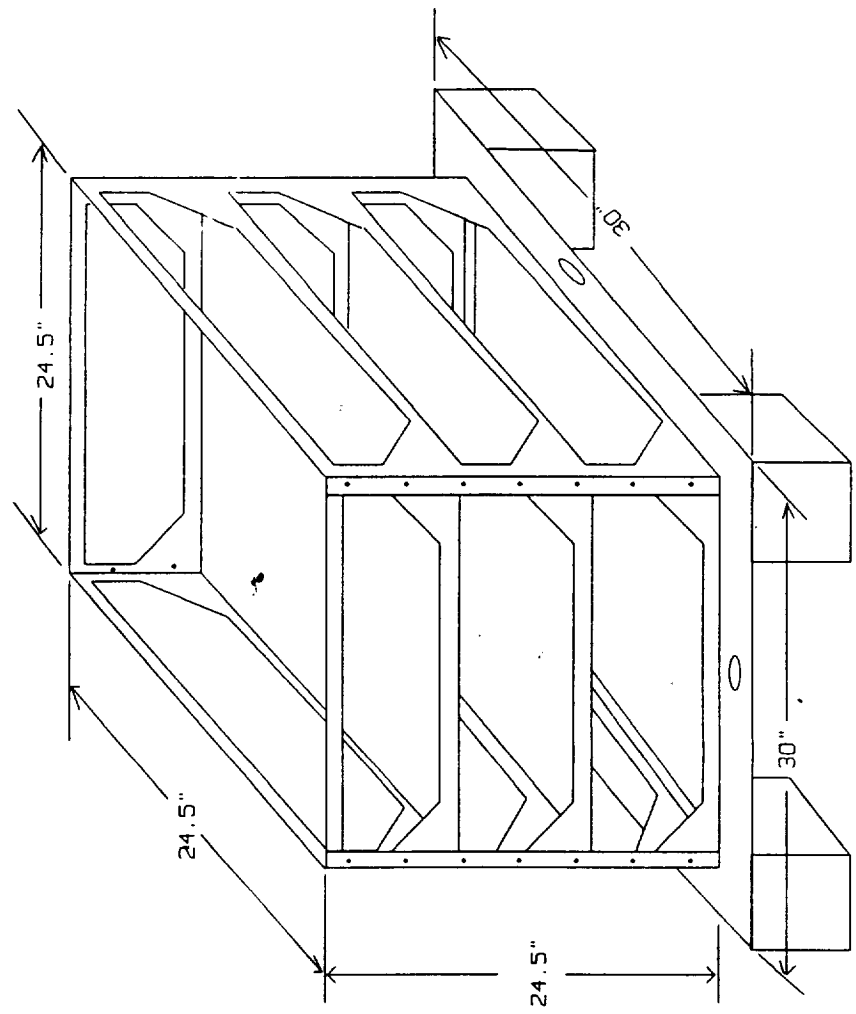

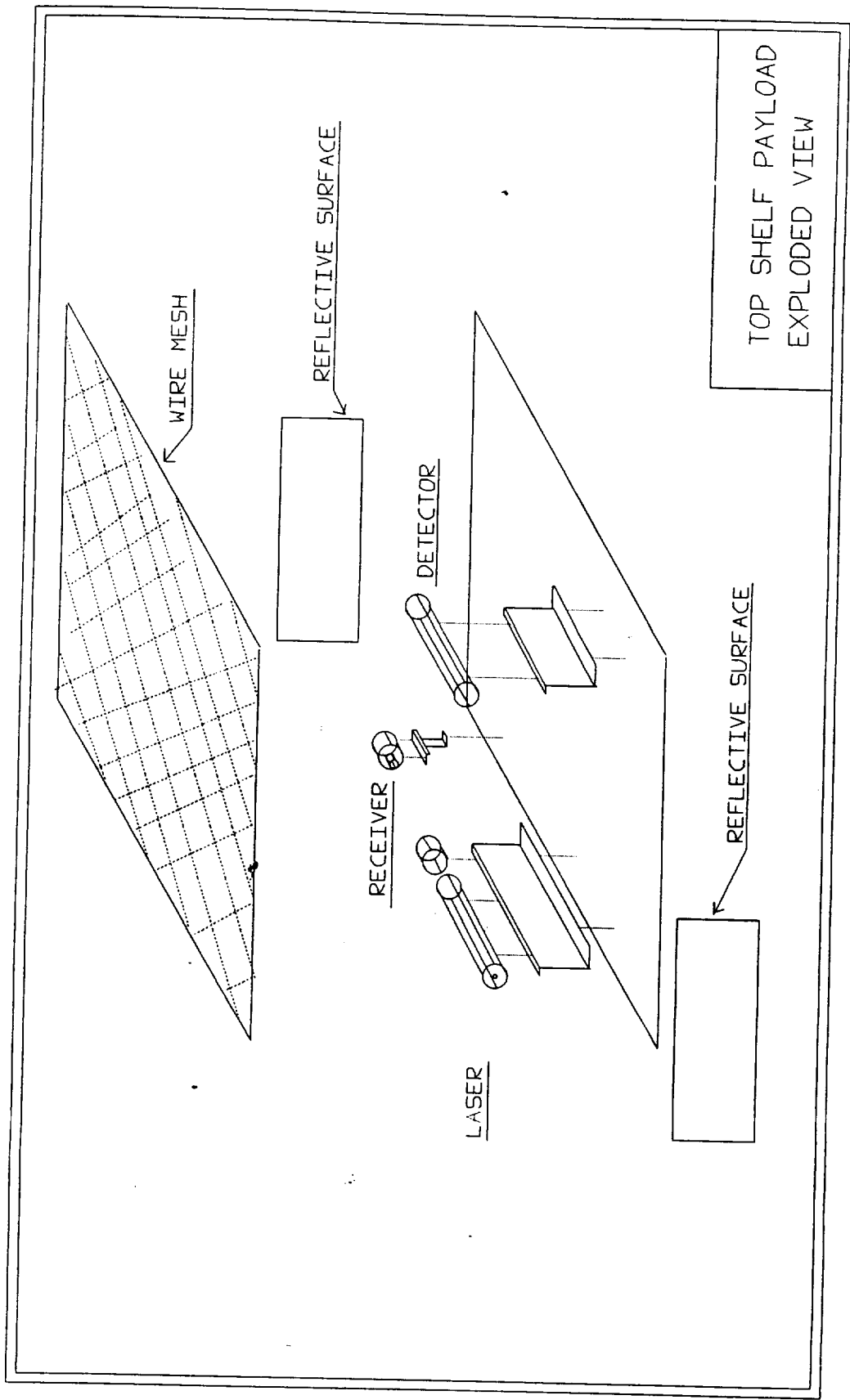

TOP SHELF PAYLOAD
EXPLODED VIEW

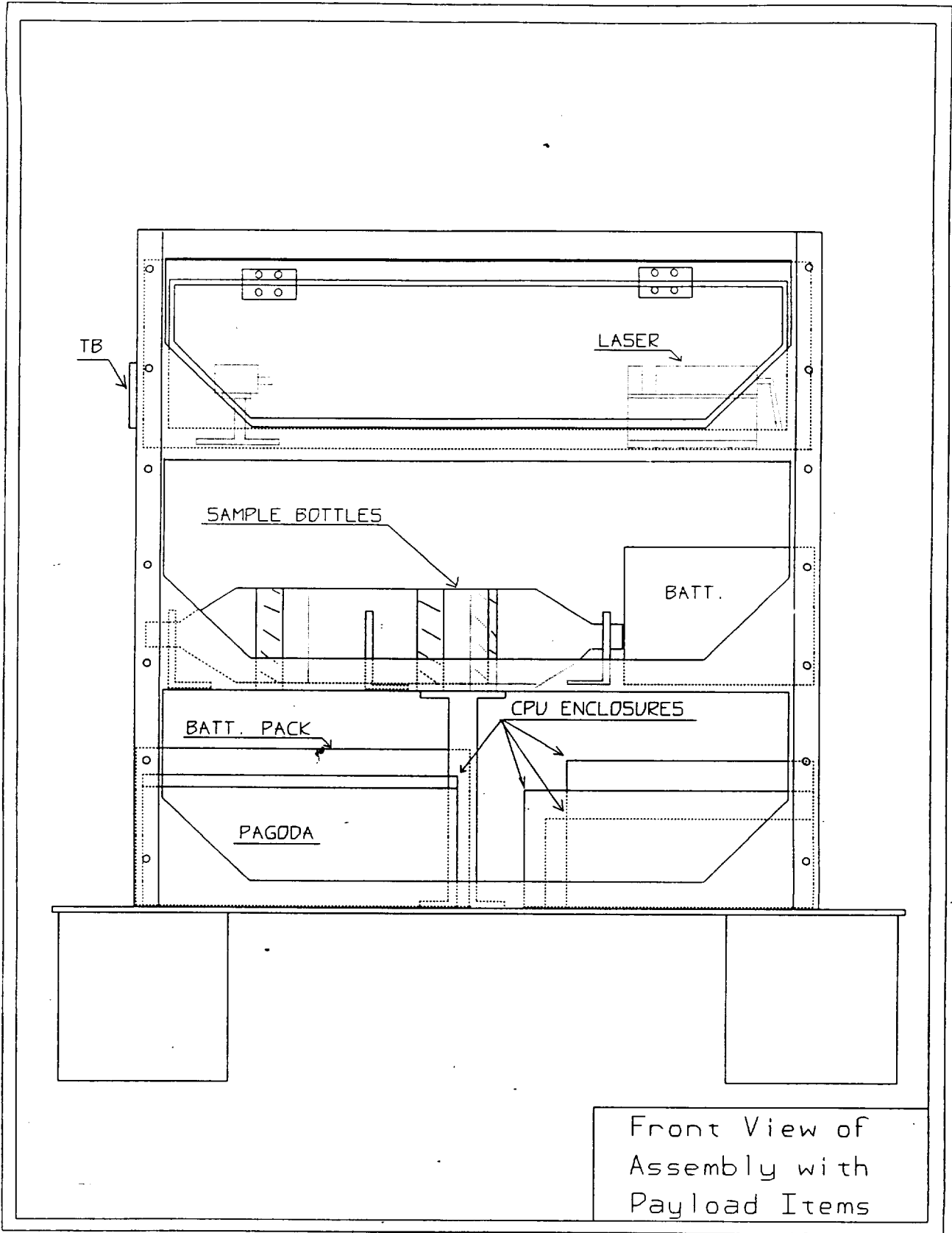

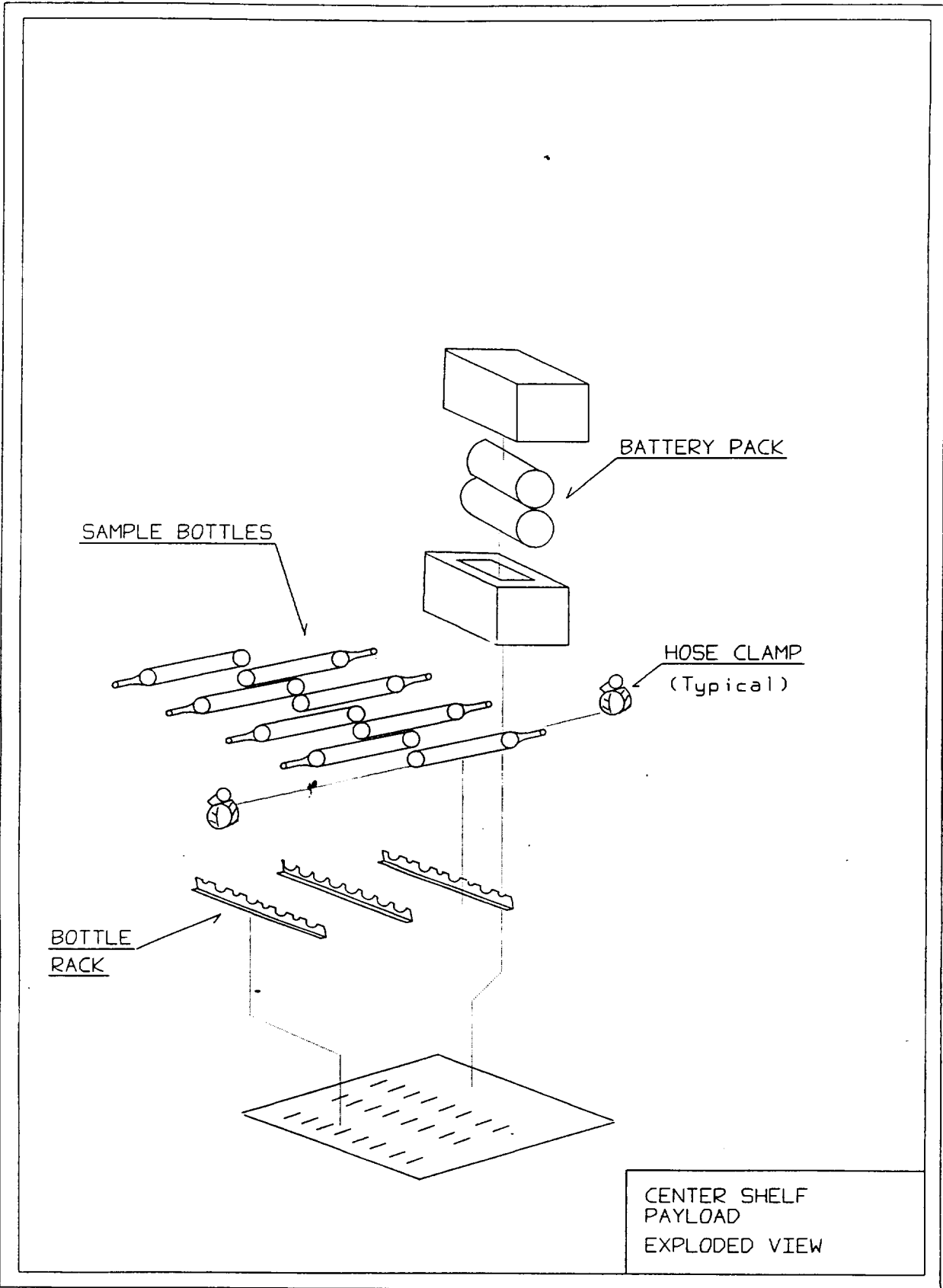

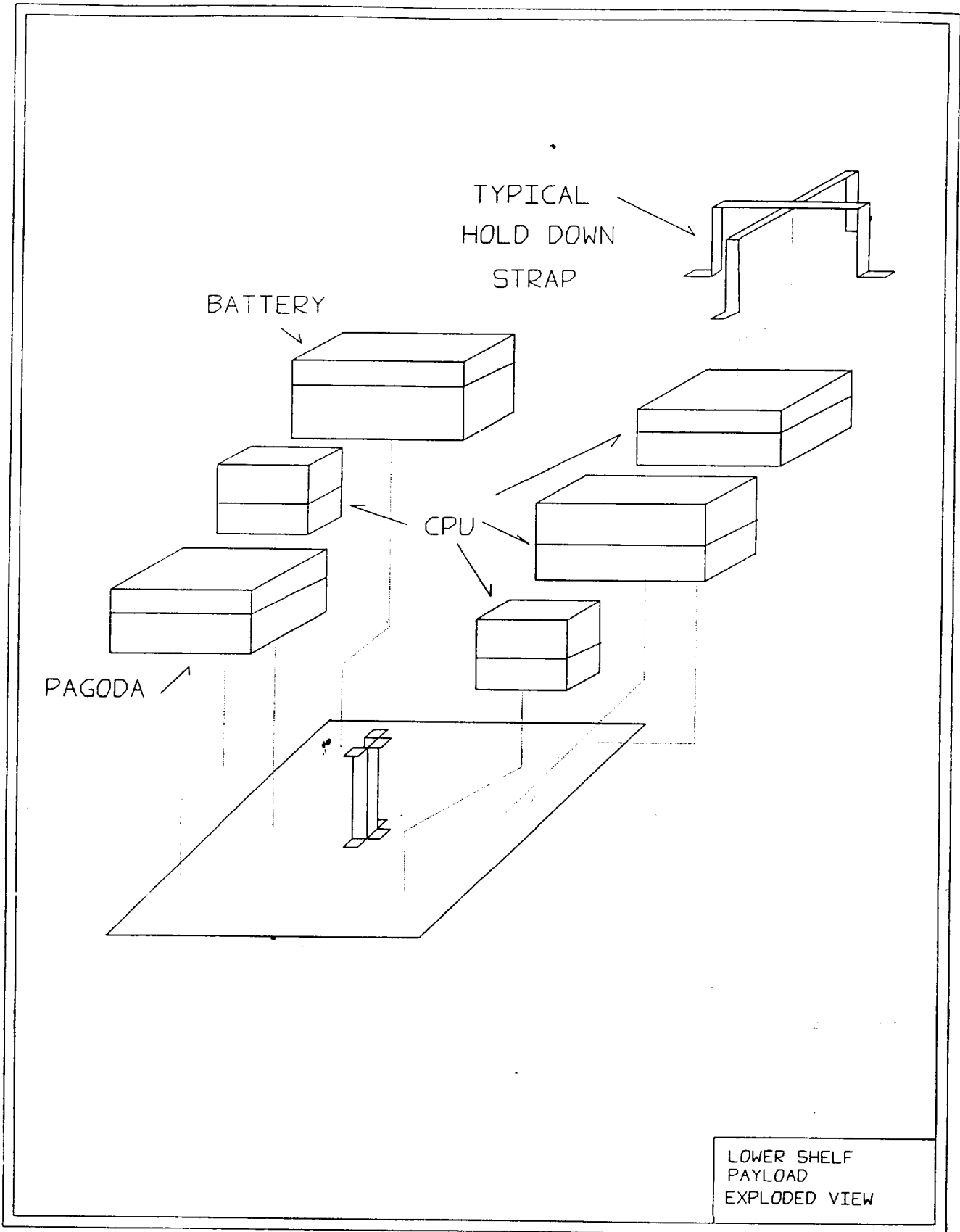

SENIOR STAFF MEETING

August 19, 1996

**9:00 a.m.
Bldg. 1219, Room 225**

9:00	Senior Staff Meeting
10:00-10:45	Report of Technology Transfer Awards Design Team
11:00-12:00	Discussion of SQF and its Deployment

**ADVANCED SUBSONIC TECHNOLOGY PROGRAM OFFICE
KEY ACTIVITIES
August 19, 1996**

- 1. HQ Employees Transfer** - On August 19, 1996, three employees from NASA Headquarters will reassign to ASTPO. Glenn Bond and Kim Cannon are Program Analysts assigned to the Program Integration Office. Bob Yackovetsky is a Technology Integration Specialist assigned to the Technology Integration Office.

- 2. Perf. & Economic Analyses Presented** - On August 9, Racquel Girvin of Douglas presented an overview of the Technology Integration Studies that have been conducted at Douglas over the past 2 years. Performance and economic analyses of many of the AST technologies were presented.

- 3. Systems Analysis Capability Reviewed** - On August 13, the Logistics Management Institute reviewed the status of the development of the Aviation System Analysis Capability (ASAC). This capability is being developed by linking models, data bases, and analysis tools via the internet. The system is currently "pass-word" protected and limited to U.S. government agencies, contractors, and approved U.S. companies. During the review, LMI demonstrated many of the capabilities that are currently available.

Charles P. Blankenship
4-6005

AIRFRAME SYSTEMS PROGRAM OFFICE

KEY ACTIVITIES

August 12, 1996

1. Lockheed Martin Skunk Works has been tasked to conduct a detailed systems study of Uninhabited Combat Aircraft (UCA). The 3-month study will identify key, high-payoff technologies required to take maximum advantage of the revolutionary capabilities that could be obtained by removing pilots from combat aircraft. As part of the study, two Lockheed Martin employees visited LaRC on August 9 to provide a status report of the study, present the three missions chosen for study, and discuss the advanced technologies to be evaluated. They requested that LaRC researchers provide inputs on the technologies chosen for evaluation and the goals selected for technology trade studies. A similar study is being conducted by McDonnell Douglas Aerospace. The technical monitor of the task is Tom Moul of ASAD.
2. The joint NASA/FAA Integrated Product Team met in Washington last week to continue preparation of the National Plan for Air Traffic Management R&D. The plan is due for approval by the end of September. During the meeting, several areas of potential overlap in NASA/FAA R&D efforts were identified. Further coordination is planned to avoid duplication of resources and effort.
3. Wade McNabb and Gordon Lehman of Parametric Technology Corporation (PTC), through a contract funded by IOG, are working with Matt Sexstone and Bob McKinley (ASAD/SAB) to demonstrate Pro/ENGINEER and Pro/MECHANICA modeling and analysis capabilities for systems studies. McNabb and Lehman have met with several SAB, MDOB, and HVPO personnel to develop a wing model for use within NASA instructional seminars and as a day-to-day tool in wing design. The model contains a generalized external mold-line geometry capable of representing most designs within the sub- and supersonic regimes. Two structural models are being developed to demonstrate generalized construction and "hands-on" design. All of the models are conceived as being "linked" to either design synthesis codes or MDO analysis and design software. Additionally, the models will be useful in demonstrating PTC software's utility in aerospace conceptual and preliminary design to U.S. industry.

Carrie K. Walker
46031

**High Speed Research Program Office
Key Activities**

August 19, 1996

- Supported the NFAC blade failure review and the subsequent feedback to the Ames recovery team as part of Roy Harris' Integrated Task Team.
- On August 14 and 15 a science review of the HSR sponsored Atmospheric Ionizing Radiation (AIR) ER-2 flight measurements and a Critical Design Review (CDR) of the instrument payload integration were conducted at the Langley Research Center. Representatives from Boeing, McDonnell Douglas, the Lockheed Skunkworks team, and Ames personnel supporting the ER-2 aircraft reviewed the science plan and participated in the CDR proceedings for the instrumentation payload integration conducted by Langley AIR Review Board. The Science Plan was accepted by HSR Management, and the ER-2 payload integration passed the CDR board.

Gin Marks
41714

**Key Activities
Office of Education
August 19, 1996**

1. Dr. Arnold Schwartz, Director of the Associateship Programs of the National Research Council, reviewed Langley's NRC program August 14-16. He was given technical briefings by all 26 Langley NRC Associates and visited a number of their worksites. Dr. Schwartz stated that of all the labs participating in the NRC program, Langley does the best job of recruiting minorities and women. He expressed a concern, which he characterized as a "double whammy," that R is not only the only Code to terminate direct support for NRC Associates at its Centers, but simultaneously is stripping Langley RTOP's that are uncoded because of Code F delays in the obligation of Langley funds to the NRC for the Associates. He plans to discuss this issue in the near future with Dr. Whitehead, who was himself an NRC Associate in the 1970's.

2. NASA is sponsoring a series of workshops for science, mathematics, engineering, and education faculty involved in the education of future teachers. Currently, LaRC is scheduled to be the site of the workshop for February 1997. Termed Project Nova, the workshops are based on successful university faculty development models that emphasize:

- enhancing faculty in the areas of instruction, content, educational technology, and using the Internet and other technologies in teaching;
- developing an action plan for implementing the framework; and
- providing examples of interdisciplinary collaboration, partnerships, and resources.

3. The NASA Summer High School Apprenticeship Research Program (SHARP) presented its closing ceremony Friday, August 16, at 1:30 p.m., in the Pearl I. Young Theater. Curtis Graves, Minority University Program Manager, NASA Headquarters, Code EU, spoke at the ceremony and presented awards to the participants. This ceremony represented the culmination of a 9-week career exploration activity in which 23 high school seniors successfully participated. SHARP was established in 1980 to provide an opportunity for high school students who aspire toward careers in engineering, science, and/or mathematics, to work as apprentices with practicing engineers and scientists. Since its inception at LaRC, 380 high school juniors and seniors have completed the program.

4. ICASE held a workshop on approximation and surrogate methods in engineering analysis and optimization August 12-16, in Building 1192C, Room 124. Speakers covered such topics as applications in MDO: techniques to identify and address interdisciplinary coupling; the use of approximation models in optimization; and the validation of approximations and surrogates. Speakers were from LaRC, Boeing, Massachusetts Institute of Technology, General Motors, ICASE, Virginia Polytechnic Institute and State University, and a number of other schools.

**Sam Massenberg
45800**

**Internal Operations Group
Key Activities
August 19, 1996**

1. Agreement has been reached on the technical details of a license and memorandum of agreement (MOA) to transfer Langley Research Center (LaRC) Gas Filter Correlation Radiometer (GFCR) remote gas sensor technology to MERCO, Inc., a small, minority-owned Colorado business. MERCO will commercialize GFCR for the monitoring of atmospheric species in the chemical manufacturing and petrochemical refining industries. Representatives of the Technology Applications Group and MERCO are currently discussing the time, place, and other details of a license-signing ceremony.
2. Messrs. J. Milam Walters and Albert E. Motley III of the Systems Engineering Office, Aerospace Mechanical Systems Division, attended a meeting of the NASA Systems Engineering Improvement Team (SEIT) at the Jet Propulsion Laboratory in Pasadena, California, on August 7-9. Mr. Walters led the group in a goals analysis exercise which should serve as the basis for development of a SEIT Charter. The SEIT will report on its progress at the next meeting of the Engineering Management Council. The group will continue to meet, with the goal of assuring that NASA maintains a world-class SE capability.
3. Boundary layer flow transition detection images using the Temperature Sensitive Paint (TSP) technique have been produced in the National Transonic Facility on the 2.2 percent High Speed Research Ref H model. TSP image data showing laminar to turbulent boundary layer transition was obtained on air mode (+120°F) and cryo mode (-100°F). Images in air and cryo modes correlate very well at the same Mach number and Reynolds number. This technique development is a team effort between NASA (Aerodynamics Division and Experimental Testing Technology Division), industry, and university partners.
4. The Facilities Program Development Office (FPDO) has facilitated a memorandum of agreement (MOA) between Langley Research Center and Old Dominion University (ODU) which allows ODU to operate the 30- by 60-Foot Full-Scale Wind Tunnel as a private venture. This is an interim MOA which will remain in effect until it is superseded by the final MOA, or until October 30, 1996, whichever occurs first. Due to the time required to complete the final MOA, the interim MOA concept

was used to allow ODU early access to the facility to begin preparations for a critical test of a U. S. Air Force F-15 model nose cone for Wright Aeronautical Laboratories. Details to be included in the final MOA are presently being worked by the FPDO and the Office of Chief Counsel, and the final MOA is expected to be completed before the interim MOA expires.

5. On August 13-15, Mr. Joe Chavis, Logistics Manager at Dryden Flight Research Center, visited the Small Purchase Facilitation Project Office (SPFPO) and the Logistics Management Office (LMO). The SPFPO provided a detailed overview of the Just-In-Time (JIT) process, World Wide Web applications, and bankcard program. The LMO provided an overview of the reduction of office supplies from the supply system and other logistics operations. Mr. Chavis was impressed with LaRC's progress thus far.
6. Four technicians from the Operations Support and Fabrication Divisions (Scott Young, Leon Harris, Bill Fogle, and Nancy Holloway) returned Friday from 2-weeks' participation in the 1996 Experimental Aircraft Association, Oshkosh, Wisconsin Fly-In. Working with technicians from other Code R Centers, they staffed the Craftsmanship Display which was part of the NASA exhibit in the NASA pavilion. The trades represented model makers, instrumentation fabricators, machinists, sheet metal fabricators, and research facility technologists (tunnels and labs). The main thrust of the display was the hands-on access to new technology and techniques currently being used or developed at the NASA Centers and having someone on hand to facilitate the transfer of technology to the public. Some of the items displayed were various electronic sensors, machined inlet nozzle models, F-18 inlet nozzle model, spin models, F-18 free flight model, resin transfer molding, carbon-carbon pistons, composites and metals, working scale model of 7- by 10-Foot Wind Tunnel, microgravity demonstration, and a scale model of the 52-foot centrifuge. The Craftsmanship Display was one of the most popular displays in the pavilion.

Bruce A. Conway

**OFFICE OF THE CHIEF FINANCIAL OFFICER
KEY ACTIVITIES**

August 19, 1996

1. A System demo of the Fab PRs and Fab changes in EPRS occurred on 8/1/96 by NCI. All requested changes to the new Fab PRs in EPRS were completed on 8/14/96. Final system review by FMD occurred on 8/15/96. System scheduled to be productional on 8/19/96.
2. PRD has worked with Code R, R&PM team to prepare R&PM "best and final" estimates for FY 1996. Response was sent to Code RB on 8/16/96.
3. The Closeout Committee has started to prepare for the 97 closeout. The kick-off meeting occurred on 8/9/96. The committee is currently preparing the closeout calendar. Judy Evans of FMD is Chairing the committee this year.

Joe Struhar
48084

OFFICE OF EQUAL OPPORTUNITY PROGRAMS

Key Activities
August 19, 1996

- There were 208 in attendance at the FWPC Awards Ceremony program, August 15, at the Reid Conference Center. Guest speaker, Jeanne Evans, Chief of Staff for Congressman Owen Pickett, spoke on proposed civil service legislation. The winners of the FWPC awards were Pamela Rinsland, Supervisor of the Year, and Marny Skora, Employee of the Year. A group of employees from Wallops attended via a bus provided by the AFGE Local 2755, who co-sponsored the program. Other co-sponsors were OEA, and the Langley Chapter of Federally Employed Women.
- OEOP and the Satellite Committee for People with Disabilities are sponsoring a disability awareness program on August 21, 1996, 2:00 p.m. at the Pearl Young Theater. The guest speaker is U.S. Army Sgt 1st Class Dana Bowman, a double-amputee member of the Army's elite Golden Knights Parachute Team, who inspires others with his courage and determination. All employees are encouraged to attend.
- Vivian Merritt and Dollie McCown are attending the Eleventh Annual Conference on Federal Dispute Resolution in Anaheim, California, August 19-22, 1996.
- Patsy Campbell will attend the 13th Annual Conference of the National Association of Public Sector Equal Opportunity Officers, August 25-28, 1996.
- Gerri Rankin will participate in the annual Scholars Program Orientation at Spelman College in Atlanta, Georgia, August 23, 1996.

Vivian B. Merritt
43289

OFFICE OF EXTERNAL AFFAIRS
KEY ACTIVITIES
WEEK OF AUGUST 19, 1996

1. NEWS RELEASES:

- a. Langley August Story Opportunities
- b. "Teachers Spend Summer School At NASA" (TEI hometown releases)

2. MEDIA/NON-MEDIA INQUIRIES:

- a. Military Space - interviewed Larry Hunt re LoFLYTE
- b. BBC-Radio - interviewed Larry Hunt re LoFLYTE
- c. VA Living Museum: GAS payload info and meteorite ownership laws
- d. Daily Press - to interview Michelle Ferebee for series on community involvement
- e. International Aviation News - Tu-144 ground test
- f. Daily Press - Plan story about PEM West mission
- g. GRB Entertainment - wind shear
- h. The Cape TV show - NASA clip art/graphics
- i. Dynamic Engineering Inc. - Photo of F-18E "dunk" test in tow tank

3. OTHER:

- a. Television coverage of our recent announcement concerning evidence of possible life on Mars has been the highest since we began measuring in March, 1995. As of yesterday, an estimated 2700 stories have run in the national and top 39 local markets.

4. PUBLIC SERVICES:

- a. Almost 160 employees, contractors and retirees have signed up to participate in the Community Day of Caring. Langley's allotment for duty status is 150 employees. Thanks to those who want to take annual leave instead, all 160 will be able to participate.
- b. In July the Public Mail Center handled 124 pieces of correspondence, 112 phone calls, 69 walk-in requests, and 37 special categories of requirements, such as for Oshkosh, State Fair and the education office. Nearly 35,000 items (fact sheets, lithos, etc.) were distributed, with 21,000 of those going to the Oshkosh airshow exhibit.
- c. Volunteers are needed to staff NASA Langley exhibits at the 1996 VA State Fair from September 26 to October 6 in Richmond. The exhibits will highlight NASA Langley activities in aeronautics, space, high speed research, World Wide Web, and education. For more information, contact Donna Roper at 42505.
- d. Over 800,000 people and 12,000 aircraft were at the Experimental Aircraft Association's (EAA) 44th Annual Fly-In at Oshkosh, Wisconsin. Exhibits included craftspersons demonstrating model making and instrumentation used in aeronautical research, researchers highlighting programs benefiting the public, a World Wide Web (WWW) and ATLAS exhibit, and Small Business Innovation Research (SBIR) companies highlighting general aviation technology. Others featured Mars Pathfinder, Mission to Planet Earth, International Space Station and the Hubble Space Telescope. Outside displays highlighted NASA Lewis' newest traveling exhibit (the Mobile Aeronautics Education Laboratory) and two general aviation aircraft with futuristic cockpit displays.

A. G. Price

Office of Human Resources
Key Activities
August 19, 1996

- Work has been completed by Rocky Edge and Pete Edgette on a smoking policy review of Bldg. 1230. Bldg. 1230 is now a "smoke-free" facility.
- Rocky Edge has begun working the impact and implementation (I&I) bargaining of the new Agency performance management plan.
- George D. Allison will attend the "Interactive Systems for Training, Education and Job Performance Improvement Conference" in Washington, D.C., on August 20-23.
- Testing for Phase II (FEHB & TSP) of Employee Express will begin Monday morning, August 19 thru August 29, 1996. Connie Lowe, Lisa Klaugh, and Linda Park will input test scenarios via telephone during times allotted by the Interagency Test Group.
- Simone Foretich attended the opening telecon for the new NASA-wide Personnel Processing Consolidation Study. The project is being led by the former Personnel Director from Kennedy Space Center and will look for cost/productivity savings in personnel data collection and documentation processes.

CMWaldal:tme 8/16/96

Office of Safety, Environment and Mission Assurance
Key Activities
August 19, 1996

1. The draft air permit for installation and operation of two natural gas fueled boilers at the Transonic Dynamics Tunnel, Building 648, was received from the Virginia Department of Environmental Quality. The permit does not require any unanticipated operational restrictions. The permit also consolidates the three existing LaRC air permits into a single Center permit.
2. Laboratory analyses of insulating fluid following retrofill of the 5 remaining polychlorinated biphenyl (PCB) transformers at LaRC indicate concentrations are below the 50 parts per million threshold. All transformers at LaRC are now documented as being below the U.S. Environmental Protection Agency threshold and no longer need to be listed as PCB transformers.
3. On August 14, a security guard manning the Durand Avenue Gate experienced a near miss accident from a stray golf ball. If the guard had not stepped back when he did, the golf ball would have struck him in the temple. Since this is not the first incident involving stray golf balls, Office of Safety and Facility Assurance (OSFA) personnel contacted Mr. John Mouring, Facilities Program Development Office, to request his assistance in working with the Air Force to eliminate the hazard. The Air Force appears to be considering the installation of a safety protection net.
4. Messrs. Charles Zeitman and Gary Carl, OSFA, participated in a procedure demonstration at the 20-Inch Mach 6 CF4 Tunnel August 12-13. Minor changes to the procedures and checklists were noted and will be processed under a Change Notification Sheet.
5. Mr. Jim Watson, Office of Mission Assurance (OMA), met with software assurance personnel of Applied Physics Laboratory (APL), Johns Hopkins University, August 7-8 in Laurel, Maryland. The APL is the Program Management Office for the LaRC Sounding of Atmosphere Using Broadband Emission Radiometry (SABER) project. The software assurance items of the SABER project were discussed. The APL Software Assurance Lead indicated that specific programmatic requirements and guidelines for software development and assurance will be issued within the next month. The APL was provided two copies of Langley Handbook 5300.4, "LaRC Software Quality Assurance Handbook." Personnel from the APL expressed significant interest in this document and were pleased that LaRC had developed it.
6. The OSFA has completed an assessment of LaRC's High Pressure Systems Certification/Recertification Program. This assessment compared LaRC's program with NASA Headquarters' requirements and programs at other NASA centers as well as several industry standards. It was concluded that LaRC does a very credible task of complying with NASA Headquarters' requirements and that the only areas of non-compliance were due to a lack of appropriate documentation or a lack of defined procedures to maintain and store documentation. To this end, the OSFA is working with Facility Systems Engineering Division personnel to generate a Certification/ Recertification Handbook for inclusion in the appropriate LaRC manual. Also, this assessment will be documented to NASA Headquarters as a self-assessment for FY 1996.

RESEARCH AND TECHNOLOGY GROUP
KEY ACTIVITIES
August 19, 1996

1. Theseus Aircraft Utilizes LaRC Technology Provided Under ERAST Program

On May 24 and July 1, 1996, the Theseus remotely piloted aircraft made its first and second flights, respectively. The wing joint in the Theseus aircraft was developed with assistance from LaRC. In addition, LaRC provided much of the material properties data for the carbon/epoxy composites used to construct the aircraft. Theseus is a high-altitude, long-endurance remotely piloted aircraft being designed and built by Aurora Flight Sciences under the auspices of Code Y (Mission to Planet Earth). The ultimate purpose of this aircraft is to provide a platform from which in-situ measurements of atmospheric properties can be made at altitudes up to 27 km (~89,000 ft). Support for Theseus from LaRC was provided by the Environmental Research Aircraft and Sensor Technology (ERAST) program.

2. Goddard and LaRC Joint Proposal for Near-Sun Flyby Mission to be Funded by Office of Space Science

The proposal is entitled "Development of Ion and Electron Plasma Instrument Including Field of View Design Concepts for the Near-Sun Flyby Mission." Dr. Wallace Vaughn (Environmental Interaction Branch, MD) is one of the co-investigators. Dr. Vaughn will be responsible for the construction of a prototype carbon-carbon composite shield to protect an electrostatic plasma mirror from direct solar radiation during the near sun flyby. Surface temperatures of the shield are expected to reach between 2500 and 3000°K (4000 to 5000°F).

3. Materials Division to Provide Independent Review of Space Shuttle External Tank Cracking

John Wagner (Metallic Materials Branch (MMB), MD) was contacted by personnel from Marshall and requested to participate in an independent review of cracking that has been observed in the Space Shuttle External Tank (ET) after proof testing. Several cracks up to 1.0 inch in length have been detected in the heat affected zone of welds that join 2219 Al extrusions to plate in ET 89 and ET 90. In addition to serving as a member of the independent review team, MMB has been asked to conduct an independent metallurgical assessment of the material in question using the facilities in the Light Alloy Laboratory.

4. LaRC Human Lunar Return (HLR) Aerobrake Structures and Materials Team Provides Support for Initial Cost Estimate

The LaRC team supported the review to Johnson Space Center (JSC) HLR Program Management by developing and providing estimates of the manpower, testing, and hardware required to design, develop, test and build the aerobrake shell structure, line joints, payload support equipment (in Shuttle Cargo Bay), and mission particular on-orbit assembly equipment. A major assumption for the estimate is that all of the aerobrake Phase A and B work will be performed in-house at NASA using Civil Service personnel, and phase C and D will be the responsibility of a Prime Contractor. As a result, the manpower commitment for Structures and Materials tasks from JSC and LaRC is substantial through Phase B.

5. Aerodynamic Predictions for Hyper-X Configurations Provided to McDonnell Douglas

Euler CFD solutions were obtained by GDD personnel for the Mach 7 free-flyer inlet-closed (FFIC-7) configuration and the Mach 7 single-stage booster (SSB-7) configuration at Mach numbers of 4, 5, and 7. These predictions will be used by McDonnell Douglas to benchmark engineering analysis codes and to complete the aerodynamic database for Hyper-X configurations. Calculations are currently underway for the Mach 7 free-flyer inlet-open (FFIO-7) configuration.

6. GDD Personnel Participate in Hyper-X Flight Test Program Review

Jeff Hodge and Randy Heard (GDD) visited McDonnell Douglas Aircraft (MDA) Hypersonics Center and Phantom Works in St. Louis for a 2-day review of the Hyper-X Flight Test Program. The meeting was attended by representatives from LaRC, Dryden, MDA, Pratt & Whitney, and General Applied Science Lab. Messrs. Hodge and Heard discussed vehicle design issues critical to installation of the flight article in LaRC's 8-Foot High Temperature Tunnel (HTT), such as model attachment to the force measuring system, fuel system interfaces, etc. MDA personnel will visit the 8-Ft. HTT to tour the facility and obtain additional information concerning model logistics (handling capabilities, repair facilities, etc.) and instrumentation.

7. HPCC CFD Code Selection Completed for Integration with Advanced Optimization Method

The HPCCP team at LaRC is developing the Framework for Inter-Disciplinary Optimization (FIDO), an integrated software/hardware capability for use in the design of advanced aircraft, such as the High Speed Civil Transport. A high-fidelity analysis capability is now being developed within FIDO. An LaRC-developed Navier-Stokes aerodynamics code, CFL3D, has been officially selected as the aerodynamic analysis code in the high fidelity version of FIDO. Selection was based on the criteria of industry acceptance, FIDO integration, sensitivity analysis and code maintenance.

8. High Intensity Radiated Field (HIRF) Lab Test Chambers Shown to Consistently Model Aircraft Compartment Characteristics

On July 26, 1996, Naval Surface Warfare Center, Dahlgren Division (NSWCDD, Dahlgren, VA) and Northeast Consortium for Engineering Education (NCEE, Monument, CO) personnel reviewed work performed for NASA and the Navy to demonstrate the validity of mode-stirred susceptibility testing. They presented stirring-ratio and insertion-loss data that appeared to indicate a statistical, geometry-independent consistency among test chambers and aircraft compartments. The data were obtained in the LaRC and NSWCDD reverberation test chambers and inside a B707 and NASA's B757 aircraft. If these data are confirmed, then testing in mode-stirred chambers such as at LaRC can reduce cost of testing for high-intensity radiated field effects.

Key Activities
Space and Atmospheric Sciences Program Group
August 19, 1996

1. Dr. David M Winker will be discussing retrieval algorithms with PICASSO science team members at the University of Washington, in Seattle, Washington, August 21. From there, he will be joined by Thomas P. Charlock and Patrick Minnis (ASD) at the 1996 International Radiation Symposium in Fairbanks, Alaska, where they will each present a paper.
2. The Advanced Instrument Controller, an extension of the radiation-hard micro-controller developed by Langley and Boeing under Code X funding, has been selected for demonstration on the Mars Microprobe Project. The Langley/Boeing microcontroller will be packaged in a Multi-Chip Module (MCM) with data acquisition circuits and will provide the Command and Data Handling functions for the penetrator. Funding for the MCM is being provided by The Phillips Laboratory and the New Millennium Program Office. Jerry Tucker of the Aerospace Electronic Systems Division is the technical lead for the Langley effort. The aeroshell geometry for the instrumented penetrator will be designed by a Langley team.
3. Davy Haynes participated at the X-34 Program kick-off meeting at Orbital Sciences Corporation (OSC) August 8. All of the OSC-NASA task agreement negotiations have been completed and a firm, fixed-price contract is being prepared with an expected Authority To Proceed of August 15, 1996. An early start for the Langley tasks was authorized and we have begun wind tunnel testing to validate the aerodynamic/aerothermodynamic characteristics of the OSC X-34 design.
4. The SSSO has been asked by the Office of Space Science to conduct an independent review of the Stardust mission. The independent review will be conducted in conjunction with the program PDR in late September. The SSSO is coordinating with other Langley organizations to support this independent assessment effort. This effort will culminate in a written report and presentation to the Office of Space Science management in October.
5. The SSSO is assisting the Office of Mission To Planet Earth, with planning the Earth Systems Science Pathfinder (ESSP) step 2 evaluation. Four representatives from each Center will support the ESSP evaluation. The SSSO is coordinating with other organizations to identify Langley support for this effort. The step 2 evaluation will take place in December 1996 and January 1997.
6. The SAGE III Electronics Subsystem Table Top CDR will be held at Ball Aerospace this week, with Tom Shull as Chair. This will conclude Instrument Subsystem CDRs. Also held this week, will be Component CDRs for the Data Storage Unit (DSU), and Ground Support Equipment (GSE), which will conclude all Component CDRs. The SAGE III Systems CDR remains on schedule for August 28-29.
7. The SAGE III Team continues to prepare for the September 9-13 Technical Interface Meeting (TIM), in Istra, Russia. Members of the Team will also participate in the French CNES Spot 5 TIM on September 16-17, and continue to the ESA Hexapod Project TIM on September 18-19, in Torina, Italy.

**TECHNOLOGY APPLICATIONS GROUP
KEY ACTIVITIES**

August 16, 1996

NASA Exhibits at Oshkosh Airshow

The 1996 Oshkosh Airshow, drew an estimated 800,000 people and the NASA exhibit was visited by an estimated 50,000 people. The exhibit's theme, Power for the Future, provided information on NASA's aerospace technologies such as the energy efficient turbine engine program.

Of particular interest to visitors were:

- 1) NASA and the FAA's General Aviation and AGATE consortium's Atlanta Communication experiment display depicting two-way communications with aircraft flying under radar detection at the Olympic games. This received good recognition by Dr. Bob Whitehead, Code R.
- 2) NASA's SBIR program with 3 Phase II companies (2 companies recently received the prestigious Tibbett's Award in Washington, D.C., presented by Vice President Gore).
- 3) The World Wide Web (WWW) exhibit developed by Langley provided information to pilots, large/small businesses, GA enthusiasts, students, educators, parents, and business representatives, on satellite weather images, shuttle activities, airfoils, propeller design, AGATE and FAA homepages, space camp, SBIR, and educational resources within NASA, e.g. Spacelink, within NASA, as well as information on ATLAS.
- 4) NASA crafts people who demonstrated model fabrication techniques with great attention focused on carbon-carbon piston technology.

Joseph S. Heyman

"Margaret Morris" <margaret.morris@hq.nasa.gov>
 o: "Mary Mulroy" <mary.a.mulroy@lerc.nasa.gov>,
 "Arnauld Nicogossian" <arnauld.nicogossian@hq.nasa.gov>,
 "Marion Norris" <mmorris@sa.ms.ossa.hq.nasa.gov>,
 "Emily O'Brien" <emily.c.o'brien@jpl.nasa.gov>,
 "Lyn Orrell" <lorrell@hqops.hq.nasa.gov>,
 "Sandra Owen" <sandra.owen@qmgate.arc.nasa.gov>,
 "June Perez" <june.perez-1@ksc.nasa.gov>,
 "Laura Pettitt" <lpetitt@proc.hq.nasa.gov>,
 "Louise Porter" <louise.porter@ssc.nasa.gov>,
 "Pat Robins" <probins@osfms1.hq.nasa.gov>,
 "Joe Rothenberg" <joseph.h.rothenberg.1@gsfc.nasa.gov>,
 "Lucy Ruiz" <lucy.ruiz1@jsc.nasa.gov>,
 "Carolyn Saldana" <csaldana@admingw.hq.nasa.gov>,
 "Angie Salter" <angie.salter@qmgate.arc.nasa.gov>,
 "Kathy Shaeffer" <kshaeffer@admingw.hq.nasa.gov>,
 "Josie Soper" <jsoper@admingw.hq.nasa.gov>,
 "Lynne Stewart" <lynne.stewart@hq.nasa.gov>,
 "Mary Stites" <mstites@hqops.hq.nasa.gov>,
 "Don Teague" <dteague@osat.hq.nasa.gov>,
 "Kathy Truman" <ktruman@sdbu.hq.nasa.gov>,
 "Lorraine Walton" <lwaltton@pao.hq.nasa.gov>,
 "Clintaria Ware" <cware@oeop.hq.nasa.gov>,
 "Dina Wiess" <d.s.weiss@larc.nasa.gov>,
 "Kelly Wilcoxon" <kwilcoxon@admingw.hq.nasa.gov>,
 "BARBARA A WARREN" <bwarren@cfo.hq.nasa.gov>,
 "Judy Wissinger" <jwissinger@admingw.hq.nasa.gov>,
 "C Diana Cermak" <ccermak@hq.nasa.gov>,
 "Carmen Arevalo" <Carmen Arevalo@admingw.hq.nasa.gov>,
 "Roy Estess" <Roy Estess@admingw.hq.nasa.gov>,
 "B Doss" <bdoss@admingw.hq.nasa.gov>
 c: "V Coates" <vcoates@admingw.hq.nasa.gov>,
 "B Fenner" <bfenner@admingw.hq.nasa.gov>,
 "J Hoover" <jhoover@admingw.hq.nasa.gov>,
 "B Shields" <bshields@admingw.hq.nasa.gov>

-Mailer: Mail*Link SMTP-QM 3.0.2

minutes of Senior Staff and Center Director's Meeting
 August 12, 1996

The following documents the discussions addressed at the Senior Staff and Center Director's Meeting on August 12, 1996. Mr. Goldin and General Dailey were not in attendance. Action assignments have been placed in brackets [] or easy identification. Note: The Senior Staff and Center Director's Meeting was not conducted on August 5, 1996.

. AA Reports

/Reese: The Federal Dispute Conference will be held on August 18 through 22 in Anaheim, California. The conference has a broad agenda scheduled, and representation from EEO, OPM, and other agencies with whom NASA interacts concerning EEO issues, will attend. Last week, NASA received a copy of a OPM report to the White House concerning diversity issues throughout the government. Code E is currently reviewing the details of the report.

/Holz: Mr. Holz stated that budget reviews will be conducted August 13 through 15.

/Lee: Ms. Lee thanked everyone for their efforts concerning the Single Process Block Changes and the development of the questions and answers associated with it.

/Luther: The launch of the ADEOS spacecraft will be on August 16, 1996, at 12:29 a.m. The launch will have two Code Y payloads aboard, the Total Ozone Mapping Spectrometer (TOMS) and the NASA Scatterometer (NSCAT). The electronic release of the Earth System Science Pathfinder program, released on July 19, 1996, has been downloaded in excess of 11,000 times, and the submissions are due on August 15, 1996. (Note: ADEOS had a successful launch.)

/Boeder: CBS interviewed Dr. Lucid on August 12, 1996. The 1996 Astronaut

Class will be introduced in a press conference on August 12, 1996. A press conference will be conducted on August 13, 1996, at JPL to release new images from Galileo. NASA's recent announcement concerning life on Mars has captured the interest of both the national and international press with an intensity that has not been experienced in a while. Currently, the homepage concerning the Mars information has been accessed in excess of 300,000 times. Ms. Boeder thanked ARC for its efforts in making this information available to Internet users.

Z/Ladwig: Mr. Ladwig thanked HQ and the Centers for their nominations for the Hammer Award. A total of 27 NASA nominations will be forwarded for consideration. The Strategic Management Meeting is scheduled for October 8 and 9, 1996.

K/Thomas: Next week Code K will be participating in the New England Business and Technology Conference on August 19 through 20. During this conference, SAIC will be awarded a mentoring protege award. Ms. Thomas thanked KSC for its support of the Region IV(8A) Contractors Association Conference held on August 9, 1996, in Orlando, Florida.

2. AT/Mott

The OIC's and Center Directors will be receiving the OSTP Federal Laboratory Review Data from the project officer, Richard Kline, for review and comment. Mr. Mott thanked everyone in advance for giving this request their immediate attention.

The HQ Softball Challenge is underway with the first game being played on August 13, 1996 when the Codes X/S Team will play Code R, and the Codes A/Z Team will meet the E/G/H Team. The game will be held at the same field as last year, Jefferson Field at 7th and G Street, SW, at 5:30 p.m. (Note: Games were canceled due to weather.)

The Strategic Management meeting will be conducted on October 8 and 9, 1996, in Washington, DC. The location will be determined at a later date.

Center Director Reports

RC/McDonald: California has been experience extensive power outages; however, ARC has not been adversely impacted.

SFC/Rothenberg: Thermal vacuum certification for POLAR was discussed.

PL/Stone: The Laboratory experienced an extensive power outage on August 10, 1996; however, there was no impact. The Mars Pathfinder is being shipped to SC on August 16, 1996.

SC/Abbey: The 1997 Astronaut class will begin its training this week. Preparations for the launch of STS-79 are proceeding well. Several Russian cosmonauts are currently training on Mir experiments at the Center.

RC/Campbell: LeRC supported the IITA Middle School Regional Summer Computer Workshop held July 15 through 26, 1996. This workshop is another example of the way teachers are being exposed to modern computer equipment and applications. Once teachers learn how to use this technology and once they incorporate it into their classrooms, their students will then be exposed to computer technology and aeronautics applications, enhancing their educational experience.

FC/Littles: The Second Aerospace Technology Conference was a success and provided a good forum for the discussions concerning future goals and recent successes.

RE: ACTION ASSIGNMENTS WILL BE TRANSMITTED UNDER SEPARATE COVER AND TRACKED THROUGH THE HEADQUARTERS CORRESPONDENCE OFFICE. SPECIFIC QUESTIONS MAY BE ADDRESSED TO LORIE PESONEN AT 358-4525.

Distribution

Officials-in-Charge of Headquarters Offices:

B/Mr. Holz
C/Mr. Christensen
E/Mr. Reese (Acting)
F/Gen. Armstrong
G/Mr. Frankle
H/Ms. Lee
I/Mr. Schumacher
J/Ms. Cooper
K/Mr. Thomas
L/Mr. Lawrence
M/Mr. Trafton
O/Dr. Lundy (Acting)
P/Ms. Boeder
Q/Mr. Gregory
R/Dr. Whitehead
S/Dr. Huntress
U/Dr. Nicogossian (Acting)
W/Ms. Gross
X/Dr. Mansfield
Y/Mr. Townsend (Acting)
Z/Mr. Ladwig

Directors, NASA Field Installations:

ARC/Dr. McDonald
DFRC/Mr. Szalai
GSFC/Mr. Rothenberg
JSC/Mr. Abbey
KSC/Mr. Honeycutt
LaRC/Dr. Creedon
LeRC/Mr. Campbell
MSFC/Dr. Littles
NSC/Mr. Estess

Director, Jet Propulsion Laboratory:

Dr. Stone

cc:

A/Ms. Wilcoxon
B/Ms. Saldana
D/Ms. Shaeffer
E/Ms. Moore
I/Ms. McClung
O/Ms. Wissinger
T/Ms. Doss
TMC/Analysts
W-3/Ms. Soper