

NASA-CR-202085

DEVELOPMENT AND QUALIFICATION OF ALTERNATE BLOWING AGENTS FOR SPACE SHUTTLE EXTERNAL TANK THERMAL PROTECTION SYSTEM

Charles W. Williams, Martin Marietta Manned Space Systems
James G. Cavalaris, NASA, Marshall Space Flight Center

ABSTRACT

The Aerospace industry has a long history of using low density polyurethane and polyurethane-modified isocyanurate foam systems as lightweight, low cost, easily processed cryogenic Thermal Protection Systems (TPS) for ascent vehicles. The Thermal Protection System of the Space Shuttle External Tank (ET) is required so that quality liquid cryogenic propellant can be supplied to the Orbiter main engines and to protect the metal structure of the tanks from becoming too hot from aerodynamic heating, hence preventing premature break-up of the tank. These foams are all blown with CFC-11 blowing agent which has been identified by the Environmental Protection Agency (EPA) as an ozone depleting substance. CFCs will not be manufactured after 1995. Consequently, alternate blowing agent substances must be identified and implemented to assure continued ET manufacture and delivery.

This paper describes the various testing performed to select and qualify HCFC-141b as a near term drop-in replacement for CFC-11. Although originally intended to be a one for one substitution in the formulation, several technical issues were identified regarding material performance and processability which required both formulation changes and special processing considerations to overcome. In order to evaluate these material changes, each material was subjected to various tests to qualify them to meet the various loads imposed on them during long term storage, pre-launch operations, launch, separation and re-entry. Each material was tested for structural, thermal, aeroshear, and stress/strain loads for the various flight environments each encounters. Details of the development and qualification program and the resolution of specific problems are discussed in this paper.

BACKGROUND

The ozone depletion issue and associated health impacts were identified in 1974. Chlorofluorocarbon (CFC) compounds were identified as suspected contributors in 1974 and confirmed as contributors by the scientific community in 1987. In an effort to reduce the international usage of CFC production and usage, the Montreal Protocol containing phase-out timetables was established and signed in 1987. Further reduction efforts were subsequently mandated by the 1990 Clean Air Act which required CFC phase-out by year 2000. Additional pressures to accelerate the phase-out of CFCs have resulted in rising taxes and cessation of manufacture of the compounds well before 2000. Current Martin Marietta Corporation and NASA policy, in line with these mandates, requires phase-out of CFCs as soon as alternates are available. Four different foam materials are used on the ET, each tailored to its particular design/manufacturing requirements.

Investigations into replacement blowing agents for the ET foam materials were initiated in 1988 under Technical Study E1728. This investigation, successfully completed in September 1991, identified HCFC-141b as the best alternative blowing agent that was both commercially available and being proposed by major fluorocarbon manufacturers and polyurethane manufacturers. The other readily available replacement agents, HCFC-123 and Formacel R, proved to be unacceptable for ET use due to poor storage stability, marginal physical properties, and toxicity concerns. Other potential alternates (e.g., water-blown, CO₂ or other gaseous agents) would have required major changes to the chemistry of the existing foams and major modifications to the foam application process with little chance of meeting target implementation dates.

In September 1991 the ET project initiated the detail development activities and design verification testing of the four ET foams with HCFC-141b blowing agent. This task was scoped to encompass several years developmental activities covering several manufacturing lots of each foam material. The production technology was to have concluded with implementation of the

HCFC-141b blown foam materials by mid-1995. However, technical issues with two of the four foams have driven this target implementation date to mid- 1996.

SPACE SHUTTLE CONFIGURATION

The Space Shuttle is a versatile manned spacecraft and low-cost delivery system for earth-orbiting payloads. The launch configuration shown in Figure 1 consists of three major elements: a reusable manned orbiter, two reusable solid rocket boosters (SRB), and the expendable ET. The largest element of the Space Shuttle, the ET, has two major roles, to contain and deliver quality propellants, liquid hydrogen (LH₂) and liquid oxygen (LO₂), to the Space Shuttle main engines (SSME), and to serve as the structural backbone for the attachment of the Orbiter and SRBs.

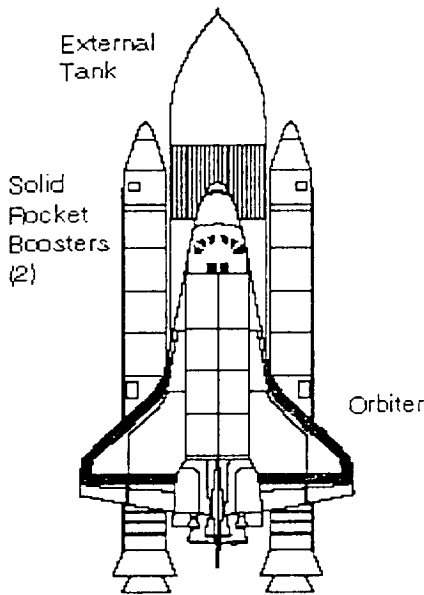

The Space Shuttle, launched from a vertical position, is powered by two SRBs and three SSMEs. At approximately two minutes into the ascent flight, the two SRBs burn out and are jettisoned. The ET remains attached to the Orbiter, providing propellants to the SSMEs for another six to seven minutes until the velocity is just short of orbital insertion. At this time the SSMEs are shut down; the ET is jettisoned for a controlled disposal. During entry, the ET flies a ballistic trajectory until it breaks up due to aerodynamic heating; the pieces fall into a predetermined ocean area. After ET separation, the Orbital Maneuvering System (OMS) places the orbiter into the desired orbit (an altitude between 100 and 500 nautical miles). Figure 2 shows a typical shuttle launch scenario.

The TPS design is driven by a number of design requirements including pre-launch, launch, and post-launch environments. First, ice/frost prevention and structural thermal limits are the key drivers for the TPS design at all ET surface

Figure 1. Launch Configuration

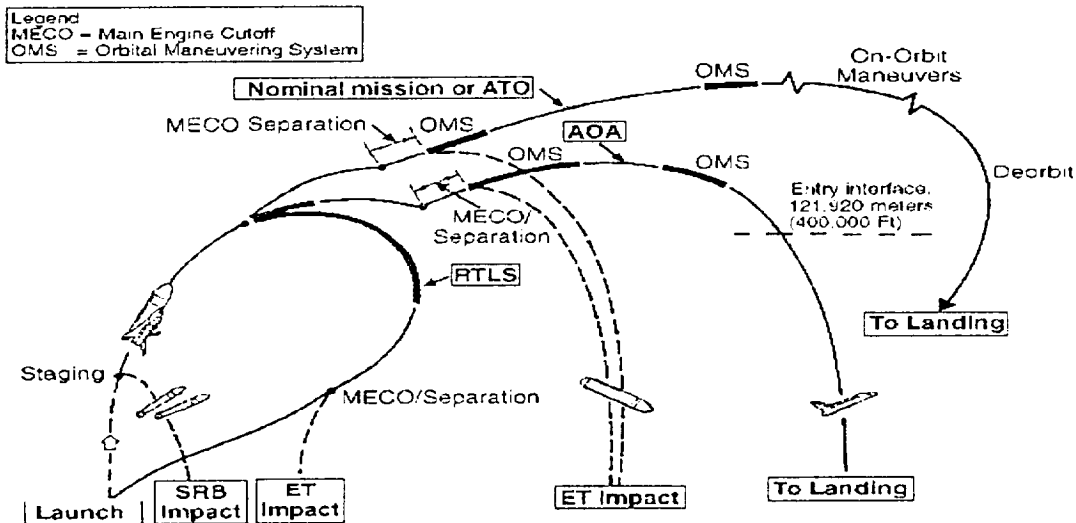

FIGURE 2. Space Shuttle Launch Profile

locations. The LH₂ tank poses additional design drivers such as air liquefaction, film boiling and propellant stratification problems. Second, due to the Shuttle's parallel, "piggyback", design and the reusable shuttle orbiter's frangible tiles, debris during flight is a major concern. The shedding of ice and/or other debris during flight operations could jeopardize the flight, compromise the mission and/or generate significant post-flight ground repair. Thirdly, the weight of the TPS accounts for approximately 10% of the empty external tank's weight. Since one pound of weight added or saved translates into about 0.9 pound of additional or reduced payload the Shuttle can carry, weight reduction is an important design driver.

Added to all the previously mentioned flight constraints, the TPS must be processable within defined processing constraints to assure material repeatability and meet predictable flight performance requirements.

The ET utilizes four different types of foams to meet its design objectives as shown in Figure 3. The majority of the LH₂, LO₂ and intertank outer structure is covered with CPR-488 (Dow Chemical Company), a nominal 2.4 pound/ft³ density polyurethane modified isocyanurate spray foam. The LH₂ aft dome is covered with a similar material, NCFI 22-65 (North Carolina Foam Industries) but is formulated at a slightly higher density, 2.9 pounds/ft³, and to have improved radiant recession properties because of its close proximity to the SRB motors.

The LH₂ domes inside the intertank, feedlines, and larger closeouts are covered with BX-250, a nominal 2.2 pound/ft³ density urethane spray foam. This material may be processed either automatically or manually and possess a much wider processing tolerance compared to either CPR-488 or NCFI 22-65. Since this material has much lower thermal limitations, it is used over SLA-561, a high temperature ablative material, in extreme high temperature areas.

For smaller closeouts, ice frost ramps, feed line brackets and small repairs, PDL-4034 (Polymer Development Labs, Inc.), a nominal 3.0 pound/ft³ urethane pour foam is used. This material has a wide tolerance processing envelope similar to BX-250, but is much simpler to use due to its manual pour processing.

Since the Space Shuttle is a man rated vehicle, the materials selected for use must meet an array of design and test requirements. Additionally, these materials must be qualified through multiple delivered lots and demonstrate repeatability of performance. The typical qualification program, beginning with the identification of potential candidates and material screening through material/process validation and implementation, is shown in Figure 4. This program, for a critically used material as TPS materials are, involve the fabrication and testing of thousands of specimens over a three to five year effort. Efforts to reduce costs and schedule have been successful through the use of Design of Experiment (DOE) and Statistical Process Control (SPC) techniques. Although it is difficult to measure actual savings, the DOE/SPC approach significantly reduced time and cost through the systematic evaluation of multiple variables simultaneously.

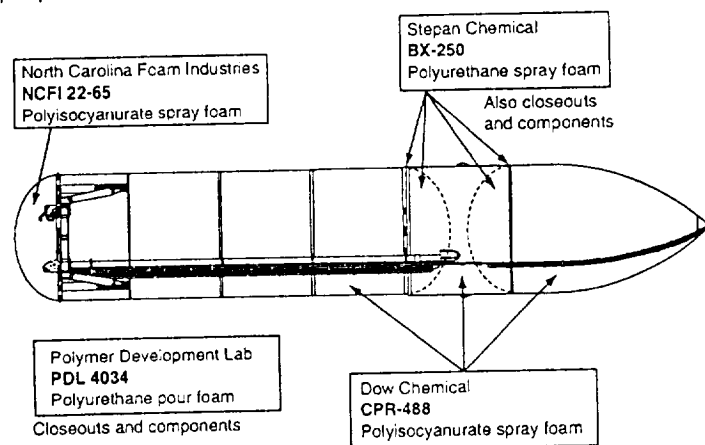

FIGURE 3. TPS Materials

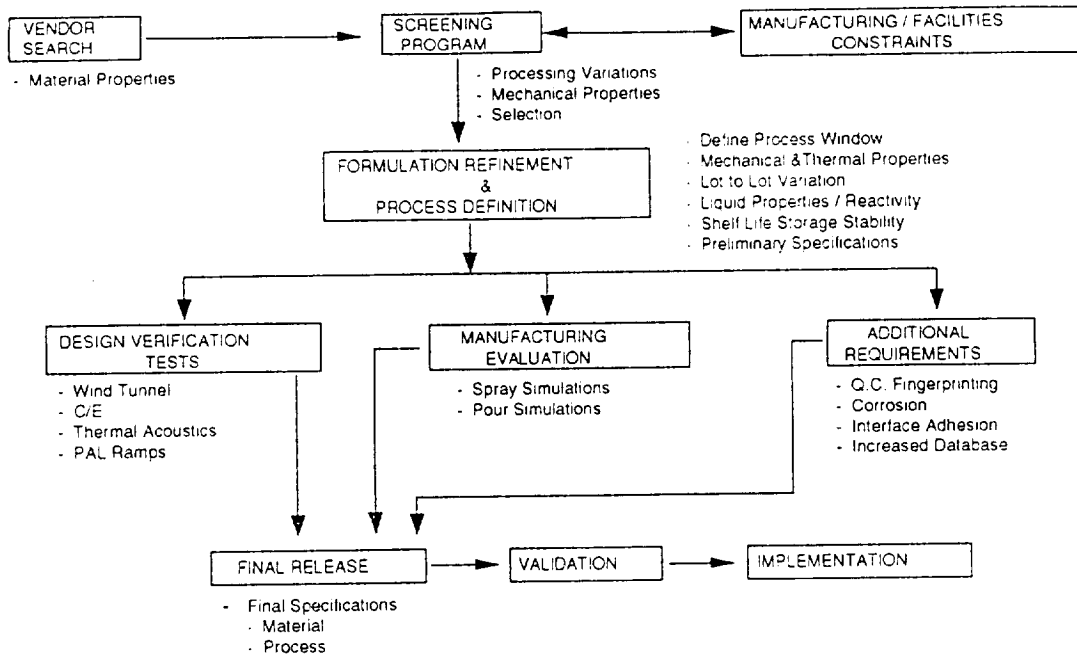

Figure 4. ET TPS Qualification Program

As can be seen from Figure 4, numerous types of testing are required to assure performance. However, certain tests have been identified as critical gates for each material. These tests are mechanical properties (tensile and compressive), physical properties (density, thermal conductivity, etc.), cryostrain (to -423°F), and ablative recession (aeroshear and radiant).

Mechanical Properties: Bond tension and compression, parallel to use, are performed at -423°F , -320°F , room temperature, $+200^{\circ}\text{F}$ and $+300^{\circ}\text{F}$ (modified polyisocyanurate foams only).

Physical Properties: Typically, densities are controlled with blowing agent and process. Average values are established for nominal processing conditions and at processing envelope extremes. Densities are controlled at the minimum required to meet mechanical and thermal performance requirements to minimize weight.

Thermal conductivity is measured through a range of temperatures, from -423°F to $+120^{\circ}\text{F}$. These curves are used to size TPS minimum thickness in areas not driven by either aero- or radiant recession.

Cryostrain: Cryostrain testing is performed at both -423°F (for LH₂ tank) and -320°F (for LO₂ tank) to establish material compatibility with the metal structure. The apparatus for performing this testing on a small scale is depicted in Figure 5 and typical test specimen loading is shown in Figure 6. As can be seen from Figure 6, stress between the aluminum structure and the applied foam is induced both thermally and mechanically (simulated tank pressurization). Although the actual tank experiences bi-axial stress, this testing is performed uni-axially but with an increased safety factor. Typical maximum stress levels are 65 KSI, which demonstrates flight loads plus 1.25% margin.

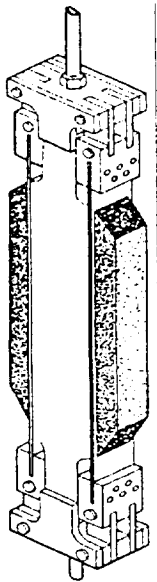

Figure 5.
Cryostrain
Test
Apparatus

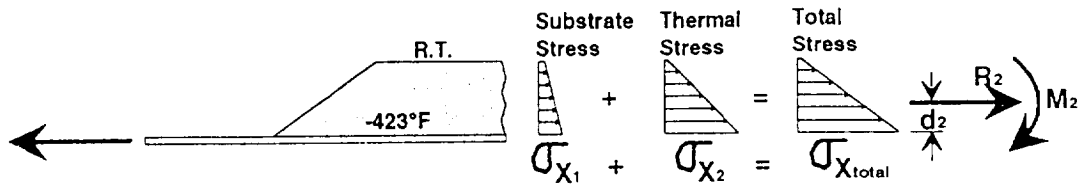

Figure 6 Gradient Cryoflex Specimen

Full scale cryostrain testing is performed on combined environment test articles as shown in Figure 7. These test articles are backface chilled to either -423°F or -320°F, mechanically loaded bi-axially to 57 KSI. The test article is then exposed to either four or ten BTU/ft²-sec heating rate using quality thermal lamps and 165 dB acoustic sand pressure to simulate lift-off environments. Due to the expense of these tests, testing is only performed after the material successfully demonstrates the ability to pass small scale testing. Typically three to four test articles are required to simulate the ET design and all critical flight environments.

Ablative Recession: In addition to the radiant recession testing performed on the cryostrain test articles mentioned above, aeroshear simulated testing is also performed on each material to establish recession rates in a convective heating environment. Two types of testing are performed to establish aeroshear recession; a small scale hydrogen fueled hot gas test chamber at the Marshall Space Flight Center in Huntsville, Alabama and a large scale Mach 10 wind tunnel facility located at the Arnolds Engineering Development Center (AEDC) in Tullahoma, Tennessee.

Heating rates from four to 12 BTU/ft²-sec are attainable in either facility. However, the hot gas test facility is used primarily for screening testing while the AEDC wind tunnel is used to establish recession rates for TPS thickness sizing. Figure 8 depicts the test specimen configuration for testing in both facilities.

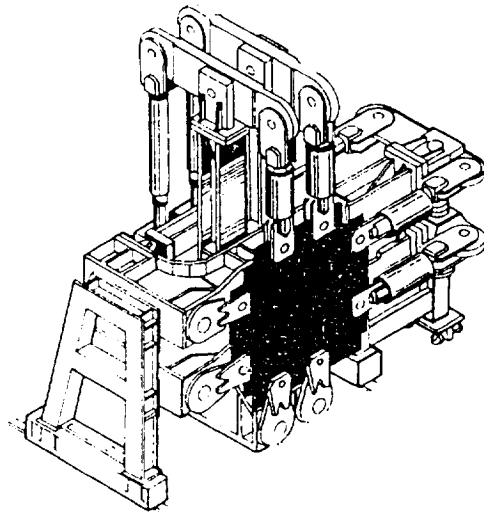

Figure 7. Combined Environment Test Article

TECHNICAL APPROACH

The CFC 11 blowing agent replacement program was identified and initiated in 1988 to screen and evaluate alternate blowing agents in ET foams. The program was set up to be performed in four Phases that would eventually conclude with qualification and implementation of existing TPS foams re-formulated with environmentally friendly approved blowing agents.

Phase 1 identified potential candidates through cooperative agreements with information sources and contacts in industry and government. R&D and regulatory actions pertaining to ozone depleting chemicals and blowing agent replacements were monitored. As a result of this activity HCFC 123, HCFC 141b and a blend of HCFC 123 and HCFC 141b called Formacel R were identified as potential candidates.

Phase 2 established cursory screening test requirements of candidate blowing agents, acquired candidate samples from pilot plant facilities, performed screening tests, and documented results and recommendations. This activity was concluded with the selection of HCFC 141b as the primary blowing based on material performance, low toxicity and shelf life stability.

During Phase 3, commercially produced quantities of blowing agent candidate materials selected from phase 2 testing were acquired. Material processing, compatibility, and sensitivity testing was performed on the selected formulations.

In Phase 4, the results of phase 3 were utilized to identify needs, establish logic flows and to define the scope of work for follow on efforts to qualify, validate and implement the selected candidates.

Initial guidelines to suppliers was to start with existing formulations and to re-formulate with HCFC 141b in lieu of CFC 11. Ideally, the objective was to maintain the density, reactivity and chemistry as close as possible to the original formulations. The logic was that HCFC 141b would be a near drop in replacement for CFC 11 and that only minor changes to the chemistry and/or processing would be required.

Processing, Testing and Results:

Final material designations formulated with HCFC 141b are shown in table 1. Each material was evaluated using simulated production processing techniques in a development area spray booth. CPR 488/XUS is normally sprayed with Gusmer H-IV proportioner and high output Binks 43PA gun at 40 lbs/min output. NCFI 22-65/24-124 is processed with the same equipment but at 20 lbs/min output. BX 250/STEPAN X13643-51 is usually processed with either a Gusmer H-II or FF proportioner and either Gusmer D or Binks 43PA spray gun. The Binks 43PA gun is used for automatic spray on domes and feed lines while the Gusmer D is used for manual hand spray applications.

Table 1

CFC 11	HCFC 141b
CPR 488	CPR XUS
NCFI 22-65	NCFI 24-57
BX-250	STEPAN X1363-51
PDL 4034	PDL 1034

CPR XUS The CPR-488 foam system containing the HCFC-141b blowing agent has been given the designation of CPR-XUS by the manufacturer, Dow Chemical. This product has been processed within the range of production spray environments in the Michoud Assembly Facility TPS Engineering spray booth and at the Huntsville facility without any changes to the existing process specification. All test results to date indicate densities and strength values equivalent to the CPR-488 foam. As a result of extensive testing, a reduction in the cryogenic strain capability of approximately 10% was identified in the CPR XUS compared to the CPR-488. Discussions with Dow Chemical also revealed that the catalyst levels in the CPR XUS were increased and the component mix ratio for reactivity measurements had changed. Automated reactivity test measurements performed to measure reaction profiles, exotherms and reaction rates confirmed these changes.

Dow agreed to reduce the catalyst level to that found in the CPR-488 foam but still maintained reactivity requirements within the CPR 488 range. Because of the cryogenic strain reduction and chemistry changes, a mini test program was also initiated at the Huntsville Operations Foam Development Lab to optimize the catalyst levels with the intent of regaining the strain capability while retaining the CPR-488 reactivity profile. This activity showed that the strain reduction appears to be inherent to the HCFC-141b blowing agent although minor improvements were made. A systems analysis has been conducted. It was concluded that this reduction has no effect on ET design criteria since total foam strain capability is well above the aluminum strain capability. The catalyst levels used in the previous lots of CPR XUS material was determined to

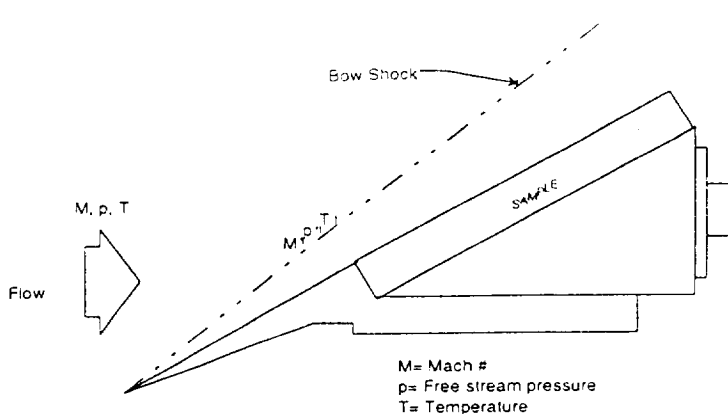

FIGURE 8. Wind Tunnel and Hot Gas Test Specimen

be not significantly different to invalidate previous test results. All data relevant to the qualification program was presented to the NASA S&E personnel for their concurrence and approval. As a result, the next shipment of CPR XUS contained an optimized catalyst package.

Ascent Recession Rates For CPR-XUS

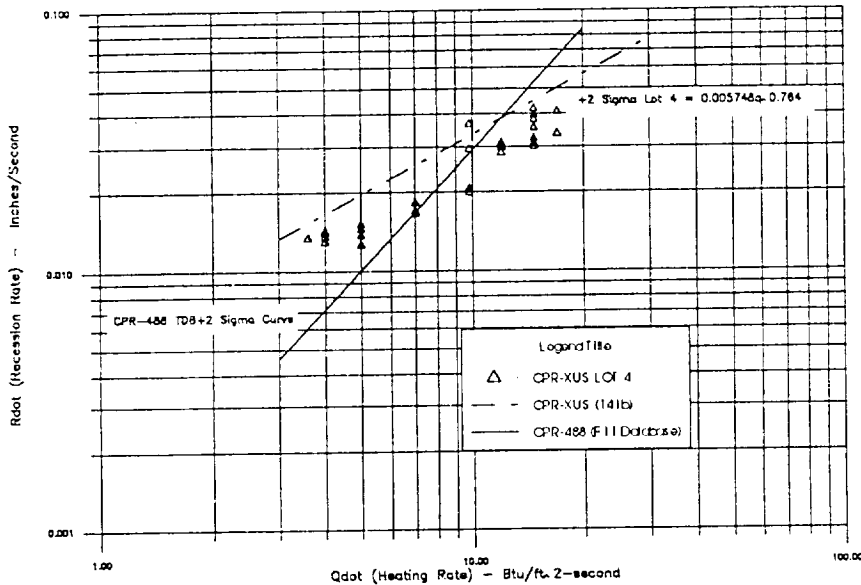

FIGURE 9. Ascent recession Rates

that the strength of the foam is exceeded. The result is a small piece of the foam, measuring less than one quarter square inch by a few cells thick blows out, thereby exposing a new surface of virgin foam to the aeroshear heating. The process continues, over and over, with more and more small divots blowing out causing a very rapid loss of material without allowing a stable char layer to be formed. Figure 9 shows the comparison of CPR XUS lots 3 and 4 compared to the CFC 11 database for aerothermal testing in the AEDC mach 10 wind tunnel facility. Lot 3 represents a reduced catalyst, equivalent to CPR 488 (CFC 11) but at a slightly higher index. Lot 4 represented an optimized chemistry version to maximize cryostrain performance. Urethane foams have not exhibited this phenomenon to any great extent since degradation of the polymer structure occurs at a much lower temperature, allowing rupture of the cells and venting of the gases. At higher heating rates above about six BTU/ft² - sec, high index foams do not undergo "pop corning" either since rupture of the cells occurs and allows a stable char formation to occur.

The conclusion of this testing indicated that the transition from CFC 11 to HCFC 141b in the CPR formulation had a negative effect on both cryogenic performance and aerothermal recession. Efforts are ongoing to understand whether the degradation in properties are the result of changes in physical properties of the blowing agent alone or in combination with the resultant chemistry changes necessitated by the blowing agent change. In either case, it is essential to resolve the issue, since implementation of the existing CPR XUS formulation would require increasing total foam thickness to avoid exceeding critical structural temperature limits in flight, thereby increasing overall flight weight significantly--an undesirable solution.

A second problem observed early in the program was an increase in aeroshear recession at low heating rates around four BTU/ft² - sec that was more pronounced than that observed with CPR 488. This increase in recession, caused by a phenomenon termed "popcorning" is the result of internal cell gas pressure increasing as a result of the aeroshear heating, combined with increasing vacuum being generated at high altitude, to a point

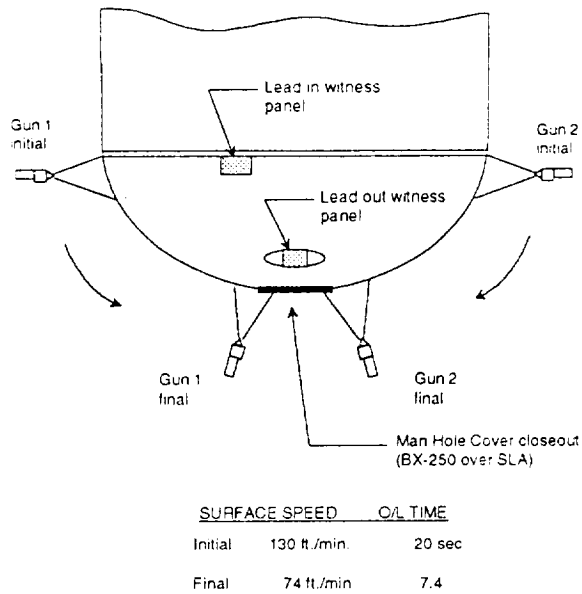

FIGURE 10. Aft Dome Processing

Testing on the NCFI 24-57 foam revealed no measurable differences in either physical, cryogenic or high heat radiant performance. A comparison of the CFC 11 and the HCFC 141b foam versions is shown in the table below.

CRITERIA	NCFI 22-65	NCFI 24-124
Spray density	2.6 - 3.1 lb./ft ³	2.8 - 3.2
Compressive strength	35 psi min	Above 45 psi
Bond tensile @ room temp	40 psi min	Above 50 psi avg.
Radiant Recession	(.0095 @ 9.8 BTU/ ft ² -sec)	Within database
Cryostrain (-423 deg F @ 65 KSI)	No delams	No delams

As can be seen from these results, NCFI 24-57 with HCFC 141b performs equally as well as NCFI 22-65 with CFC 11.

STEPAN X 1363-51 The BX 250 foam system containing HCFC 141b blowing agent, supplied by Stepan Company, was given the experimental designation of Stepan X 1363-51. As with the other materials, the BX 250 was re-formulated with HCFC 141b to meet the same density requirement and reactivity. As mentioned earlier, BX 250 is utilized in either low heating areas or in high heating areas over a Silicone Filled Ablative material and is usually processed at normal open factory environments, e.g. 70 to 75 degrees F substrate and room temperature with a material component temperature of 110 +/- 5 deg F. When processing the Stepan X 1363-51 under these same conditions problems were encountered with both cryostrain and bond tension failures. While the cryostrain failures occurred at the aluminum substrate, the bond tension failures occurred at the first knit line above the substrate. Figure 11 depicts the areas where failures were occurring.

After a thorough investigation of the failures, it became apparent that the problems were associated with the boiling point of the HCFC 141b at near 90 ° F compared to CFC 11 at near 75° F. A high density layer was being formed next to the aluminum surface due to the heat sink effect. Thus the normal exotherm was not sufficient to drive the temperature much

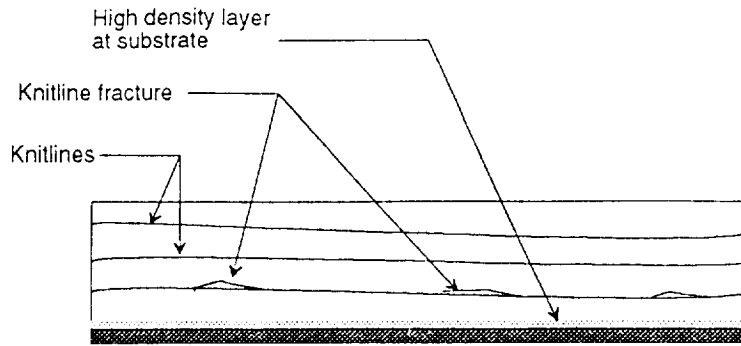

FIGURE 11. Stepan X 1363-51 Failures

above the boiling point of the 141b. The bond tension failures occurring at first knit line was interesting in that the mechanism for their occurrence was related to the second overlayer. The process requires that overlap times between successive layers be not more than 45 seconds to assure strength at the knitlines be equal to or greater than core foam strength. Apparently what was happening was that the reaction of the first layer (and rise) next to the aluminum substrate was not complete within the time allowed between passes. The exotherm of the second layer added heat to the first layer, thereby causing additional rise to occur. With the two layers rising at the same time, shear stresses developed at the interface and low strength bonds were the result. The reason this phenomenon did not occur with either of the high index foams was related to their being processed at above 90° F room temperature and above 110° F substrate temperature. The most obvious solution was to increase the component temperature to provide additional heat to the mixture to aid in boiling the blowing agent. The other approach, of increasing the spray environment temperatures, would mean extensive facilities investment which would be cost prohibitive. Through experimentation and testing it was found that the optimum component temperature was 125° F, since higher temperatures frothed the foam and caused

undesirable surface roughness and low core foam strength.

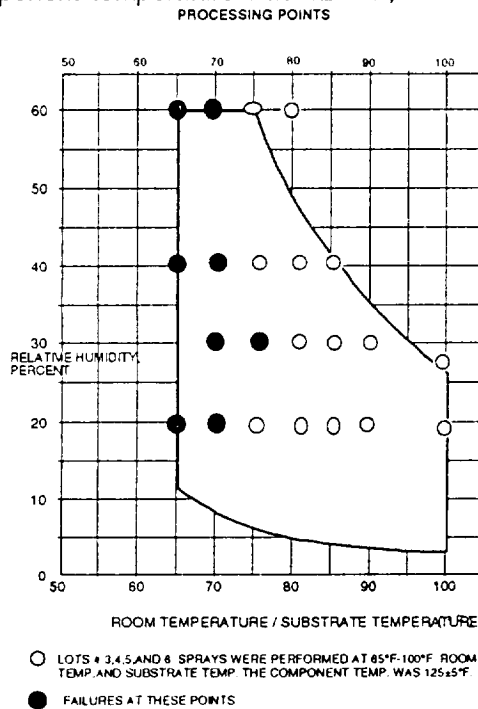

FIGURE 12. Stepan X 1363-51 Processing Failures

Results of increasing the component temperature showed much improvement in the bond tension results but did little to eliminate the cryostrain failures occurring at the substrate. Figure 12 shows the results of a parametric evaluation within the normal bounds of the processing envelope. Conclusions were that other material changes were necessary resolve the issue.

Through close co-ordination with Stepan Company, a program was initiated to investigate increased catalysts, addition of other types of catalysts and totally replacing the existing catalyst system with a new catalyst system. A design of experiments (DOE) program was initiated whereby various combinations of existing and new catalyst systems were evaluated. Interestingly, it was found that simply increasing the existing catalyst was not a very effective means of increasing the exotherm. The best formulations based on the DOE analysis appeared to be one

maintained the existing catalyst but at slightly higher concentrations plus the addition of Polycat 5 (Air Products & Chemicals), not part of the original formulation. A second optimum formulation was based on totally replacing the existing catalyst with a lead based catalyst plus a blend of Polycat 5 and Polycat 8 (Air Products & Chemicals).

These formulations were given the commercial designations of BX 255 and BX 260 respectively. Each of these formulations promised favorable results based on limited testing. Sprays were performed at the lower end of the processing window between 70° and 80° F without either bond tension failures or cryostrain failures. Efforts are on-going towards making a selection between the best formulation and continuing with full qualification.

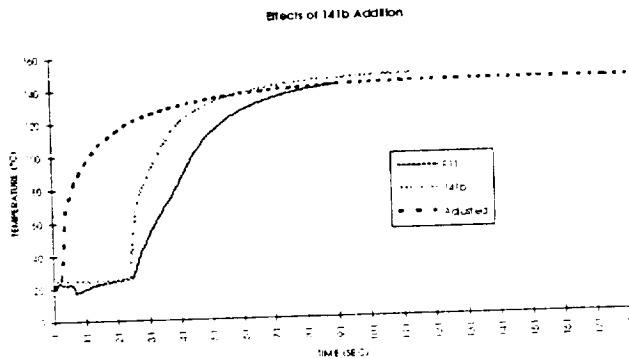

FIGURE 13. Reactivity Measurements

PDL 1034 The PDL 4034 foam system containing the HCFC 141b blowing agent has been given the designation of PDL 1034 by the manufacturer Polymer Development Laboratories, Inc. This material is used in over 300 different locations on the External Tank from large ice frost ramps over feed line brackets to small repairs measuring less than 1/2 square inch in area. Although a low index foam, its excellent thermal properties and ease of application as a manual pour foam make it a versatile material.

As with the NCFI 24-54 foam described earlier, the PDL 1034 formulation is virtually indistinguishable from the PDL 4034 foam it replaces. Since this foam is generally poured in a mold, the only observed difference has been slight changes in the charge sizes used for making the pour: generally less foam is required. The following table compares the properties of both materials.

	CFC 11	HCFC 141b
Density, lbs/cu ft	3.17	3.17
Compression, psi	42	56
Bond tension @ +200°F, psi	53	62
Bond tension @ RT, psi	104	99
Bond tension @ -320°F, psi	68	75
Bond tension @ -423°F, psi	49	44
Cryostrain @ -320° F, 60KSI	PASS	PASS

This material is currently undergoing implementation on the ET with actual applications beginning in late 1994 and completing in mid-1995.

CONCLUSIONS

As can be seen from at least two of the foams used on the External Tank, the transition from CFC 11 blown systems to HCFC 141b blown systems has not been a one for one drop in replacement. In the case of the CPR XUS, the difference may not have been noticeable in a normal commercial system but due to the extreme environments imposed on a material by the ET flight loads, unacceptable differences were observed. In the case of the Stepan X 1363-51, the differences in boiling points between the two blowing agents were significant enough to warrant significant chemistry and processing changes. However, with the other two foams, NCFI 24-57 and PDL 1034, the blowing agent differences were almost indiscernible. These two foam systems are currently approved for production validation and implementation which will begin late 1994. The CPR- and BX- formulations will require additional refinement and testing prior to their being ready for implementation. Based on preliminary results with both systems, it appears that with the proper chemistry, the problems can be resolved.