

71-100

NASA Technical Memorandum 107290

# Micromechanics Analysis Code (MAC)

User Guide: Version 2.0

T.E. Wilt  
*The University of Akron*  
*Akron, Ohio*

and

S.M. Arnold  
*Lewis Research Center*  
*Cleveland, Ohio*

August 1996



National Aeronautics and  
Space Administration

**Trade names or manufacturers' names are used in this report for identification only. This usage does not constitute an official endorsement, either expressed or implied, by the National Aeronautics and Space Administration.**

# ***M*icromechanics *A*nalysis *C*ode (**MAC**)**

**User Guide: Version 2.0**

**Developed by:**

**T. E. Wilt  
The University of Akron  
Department of Civil Engineering**

**S. M. Arnold  
National Aeronautics and Space Administration  
Lewis Research Center**

## **1.0 Introduction**

The ability to accurately predict the thermomechanical deformation response of advanced composite materials continues to play an important role in the development of these strategic materials. Analytical models that predict the effective behavior of composites are used not only by engineers performing structural analysis of large-scale composite components but also by material scientists in developing new material systems. For an analytical model to fulfill these two distinct functions it must be based on a micromechanics approach which utilizes physically based deformation and life constitutive models and allows one to generate the average (macro) response of a composite material given the properties of the individual constituents and their geometric arrangement. Only then can such a model be used by a material scientist to investigate the effect of different deformation mechanisms on the overall response of the composite in order to identify the appropriate constituents for a given application. However, if a micromechanical model is to be used in a large-scale structural analysis it must be 1) computationally efficient, 2) able to generate accurate displacement and stress fields at both the macro and the micro level and 3) be compatible with the finite element method. Additionally, new advancements in processing and fabrication techniques now make it possible to engineer the architectures of these advanced composite systems. Full utilization of these emerging manufacturing capabilities require the development of a computationally efficient micromechanics analysis tool capable of accurately predicting the effect of microstructural details on the internal and macroscopic behavior of composites. The above mentioned computational efficiency is required since 1) the large number of parameters that must be varied in the course of engineering (or designing) composite materials, and 2) the optimization of a material's microstructure will require the integration of the micromechanics model with optimization algorithms. From this perspective, analytical approaches that produce closed form expressions which describe the effect of a material's internal architecture on the overall material behavior are preferable to numerical methods such as the finite element or finite difference schemes.

A number of models presently exist that can fulfill some aspect of the aforementioned tasks. However, there are very few working models that are both computationally efficient and sufficiently accurate at the micro- as well as the macro-level. One such micromechanics model with the potential of fulfilling both tasks is the method of cells [1] and its generalization [2]. The comprehensive capabilities and efficiency of this method has been documented in references [4] and [5]. Consequently, the recently developed, computationally efficient and comprehensive micromechanics analysis code, *MAC*, whose predictive capability rests entirely upon the fully analytical micromechanics model, herein referred to as the generalized method of cells, *GMC*, [2 and 3] will now be described. *MAC* is a versatile form of research software that "drives" the double or triply periodic micromechanics constitutive models based upon *GMC*. *GMC* is capable of predicting the response of both continuous and discontinuous multi-phased composites with an arbitrary internal microstructure and reinforcement shape. *GMC* is a continuum based micromechanics model that provides closed-form expressions for the mac-

roscopic composite response in terms of the properties, size, shape, distribution, and response of the individual constituents or phases that make up the material. GMC also utilizes physically based viscoplastic deformation and life models for each constituent. Furthermore, expressions relating the internal stress and strain fields in the individual constituents in terms of the macroscopically applied stresses and strains are also available through strain or stress concentration factors. These expressions make possible the investigation of failure processes at the microscopic level at each step of an applied load history. Similarly, GMC provides the capability of studying the influence of bond strength at the fiber/matrix interface which recently has been shown to be an important damage mechanism.

**MAC** enhances the basic capabilities of GMC by providing a modular framework wherein 1) various thermal, mechanical (stress or strain control) and thermo-mechanical load histories can be imposed, 2) different integration algorithms may be selected, 3) a variety of constituent constitutive models may be utilized and/or implemented and 4) a variety of fiber architectures may be easily accessed through their corresponding representative volume elements. Figure 1 illustrates the basic flow diagram for this modular framework. The capabilities for this version of **MAC** are discussed in section 2, whereas theoretical and background information on the basic capabilities itemized above is given in section 3. Section 4 describes how one might use **MAC** and will be the most referred to section in the entire manual. Finally, section 5 gives some insights into the future modifications planned for **MAC**.

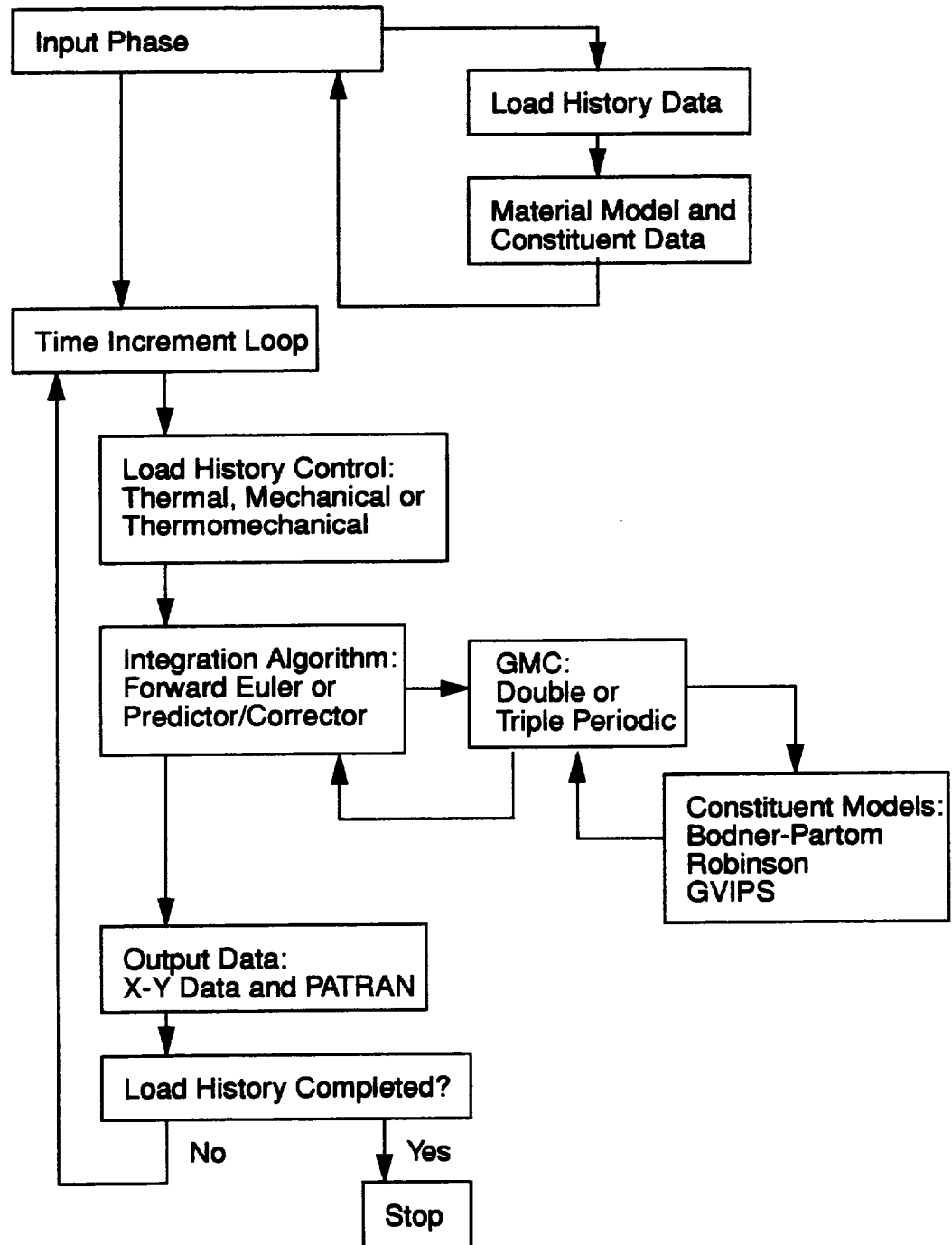

Figure1: **MAC** Flowchart

## **2.0 Current Capabilities**

In this section the current features/capabilities of **MAC** are itemized.

- **Load Types:**
  - Thermal
  - Mechanical
  - Thermomechanical
- **Aboudi GMC Models:**
  - Double Periodicity Model for continuous reinforcement
  - Triple Periodicity Model for discontinuous reinforcement
- **Graphical Output**
  - Up to 5 x-y data plot files may be generated for both macro and micro (sub-cell) quantities
  - PATRAN for subcell geometry and color results evaluation, e.g. stress, strains, inelastic strains,  $J_2$ , etc.
- **Integration Options:**
  - Forward Euler
  - Predictor/Corrector
- **Constitutive Models**
  - elastic orthotropic
  - inelastic viscoplastic models:
    - Bodner-Partom
    - Robinson
    - GVIPS
  - user defined model using subroutine USRMAT
- **Fiber/Matrix Interface Layer**
- **Laminate Analysis**
- **Fiber/Matrix Debonding Conditions**
- **Free Format Input Data**

## 3.0 Background

### 3.1 Micromechanics Models

As stated in the introduction, **MAC's** predictive capabilities rest entirely upon the fully analytical micromechanics model known as GMC which is capable of predicting the inelastic response of both continuous (double periodicity) and discontinuous (triple periodicity) multi-phased composites with an arbitrary internal microstructure and reinforcement shape. Prior to describing the available architectures (Representative Volume Elements, RVE's) within **MAC** as discussed in section 4, a brief overview of the theoretical foundation behind the generalized method of cells follows. A more complete discussion of the theoretical formulation is given in [1] - [3].

In the original formulation of the method of cells, a continuously (or discontinuously) reinforced, unidirectional fibrous composite is modeled as a rectangular, double-periodic (or triply-periodic) array of fibers embedded in a matrix phase. The periodic character of the assemblage allows one to identify a repeating unit cell that can be used as a building block to construct the entire composite. The properties of the repeating cell are thus representative of the properties of the entire assemblage. The unit cell consists of a single fiber subcell surrounded by three matrix subcells for continuous and seven for discontinuous composites, hence the name **method of cells**. The rectangular geometry of the repeating unit cell allows one to obtain an approximate solution for the stresses and strains in the individual subcells given some macroscopically homogeneous state of strain or stress applied to the composite. The approximate solution to the posed boundary value problem is, in turn, used to determine macroscopic (average) or effective properties of the composite and the effective stress-strain response in the inelastic region.

In the **generalized method of cells** for continuous (or discontinuous) fibrous composites, the repeating unit cell can consist of an arbitrary number of phases. Hence the generalized method of cells is capable of modeling a multiphase composite. This generalization extends the modeling capability of the original method of cells to include the following: 1) inelastic thermomechanical response of multiphased metal matrix composite, 2) modeling of various fiber architectures (including both shape and packing arrangements), 3) modeling of porosities and damage, and 4) the modeling of interfacial regions around inclusions including interfacial degradation.

The basic homogenization approach taken in the micromechanical analysis consists essentially of four steps. First, the repeating volume element, RVE, of the periodic composite is identified. Second, the macroscopic or average stress and strain state in terms of the individual microscopic (subcell) stress and strain states is defined. Third, the continuity of tractions and displacements are imposed at the boundaries between the constituents. These three steps, in conjunction with



micro-equilibrium, establish the relationship between micro (subcell) total, thermal and inelastic strains and macro (composite) strains via the relevant concentration tensors. In the fourth and final step, the overall macro constitutive equations of the composite are determined. These four steps form the basis of the micro-to-macro-mechanics analysis which describe the behavior of heterogeneous media. The resulting micromechanical analysis establishes the overall (macro) behavior of the multi-phase composite and is expressed as a constitutive relation between the average stress, strain, thermal, and inelastic strains, in conjunction with the effective elastic stiffness tensor.

That is,

$$\bar{\sigma} = \underline{B}^* (\bar{\varepsilon} - \bar{\varepsilon}^I - \bar{\varepsilon}^T) \quad (\text{EQ 1})$$

where for the most general case of discontinuous reinforcement with  $N_\alpha$  by  $N_\beta$  by  $N_\gamma$  number of subcells, the effective elastic stiffness tensor,  $\underline{B}^*$ , of the composite is given by,

$$\underline{B}^* = \frac{1}{dhl} \sum_{\alpha=1}^{N_\alpha} \sum_{\beta=1}^{N_\beta} \sum_{\gamma=1}^{N_\gamma} d_\alpha h_\beta l_\gamma \underline{C}^{(\alpha\beta\gamma)} \underline{A}^{(\alpha\beta\gamma)} \quad (\text{EQ 2})$$

the composite inelastic strain tensor is defined as,

$$\bar{\varepsilon}^I = \frac{-\underline{B}^{*-1}}{dhl} \sum_{\alpha=1}^{N_\alpha} \sum_{\beta=1}^{N_\beta} \sum_{\gamma=1}^{N_\gamma} d_\alpha h_\beta l_\gamma \underline{C}^{(\alpha\beta\gamma)} (\underline{D}^{(\alpha\beta\gamma)} \underline{\varepsilon}_s^I - \bar{\varepsilon}^I(\alpha\beta\gamma)) \quad (\text{EQ 3})$$

the average thermal strain tensor as,

$$\bar{\varepsilon}^T = \frac{-\underline{B}^{*-1}}{dhl} \sum_{\alpha=1}^{N_\alpha} \sum_{\beta=1}^{N_\beta} \sum_{\gamma=1}^{N_\gamma} d_\alpha h_\beta l_\gamma \underline{C}^{(\alpha\beta\gamma)} (\underline{D}^{(\alpha\beta\gamma)} \underline{\varepsilon}_s^T - \bar{\varepsilon}^T(\alpha\beta\gamma)) \quad (\text{EQ 4})$$

and  $\bar{\varepsilon}$  is the uniform applied macro (composite) strain. For the case of continuous reinforcements with  $N_\beta$  by  $N_\gamma$  number of subcells, eq. (2) - (4) reduce to the following:

$$\underline{B}^* = \frac{1}{hl} \sum_{\beta=1}^{N_\beta} \sum_{\gamma=1}^{N_\gamma} h_\beta l_\gamma \underline{C}^{(\beta\gamma)} \underline{A}^{(\beta\gamma)} \quad (\text{EQ 5})$$

$$\bar{\varepsilon}^I = \frac{-\underline{B}^{*-1}}{hl} \sum_{\beta=1}^{N_\beta} \sum_{\gamma=1}^{N_\gamma} h_\beta l_\gamma \underline{C}^{(\beta\gamma)} (\underline{D}^{(\beta\gamma)} \underline{\varepsilon}_s^I - \bar{\varepsilon}^I(\beta\gamma)) \quad (\text{EQ 6})$$

$$\bar{\varepsilon}^T = \frac{-\underline{B}^{*-1}}{hl} \sum_{\beta=1}^{N_\beta} \sum_{\gamma=1}^{N_\gamma} h_\beta l_\gamma \underline{C}^{(\beta\gamma)} (\underline{D}^{(\beta\gamma)} \underline{\varepsilon}_s^T - \bar{\varepsilon}^T(\beta\gamma)) \quad (\text{EQ 7})$$

In the above equations matrix notation is employed; where, for example, the average stress,  $\bar{\sigma}$ , average applied strain,  $\bar{\epsilon}$ , and inelastic subcell strain,  $\epsilon_s^I$ , vectors represent,

$$\bar{\sigma} = \{\bar{\sigma}_{11}, \bar{\sigma}_{22}, \bar{\sigma}_{33}, \bar{\sigma}_{12}, \bar{\sigma}_{23}, \bar{\sigma}_{13}\} \quad (\text{EQ 8})$$

$$\bar{\epsilon} = \{\bar{\epsilon}_{11}, \bar{\epsilon}_{22}, \bar{\epsilon}_{33}, \bar{\epsilon}_{12}, \bar{\epsilon}_{23}, \bar{\epsilon}_{13}\} \quad (\text{EQ 9})$$

$$\epsilon_s^I = \{\bar{\epsilon}^{I(111)}, \dots, \bar{\epsilon}^{I(N_\alpha N_\beta N_\gamma)}\} \quad (\text{EQ 10})$$

where the six components of the vector  $\bar{\epsilon}^{I(\alpha\beta\gamma)}$  are arranged as in eq. (9). Similar definitions for  $\epsilon_s^I$ ,  $\bar{\epsilon}^{I(\alpha\beta\gamma)}$  also exist. Note that the key ingredient in the construction of this macro constitutive law is the derivation of the appropriate concentration matrices,  $A^{(\alpha\beta\gamma)}$  and  $D^{(\alpha\beta\gamma)}$  having the dimensions 6 by 6 and 6 by  $N_\alpha N_\beta N_\gamma$  respectively, at the micro (subcell) level. The definitions of  $A$  and  $D$ , although not given here, may be found in references [2] and [5]. Finally, the matrix  $C^{(\alpha\beta\gamma)}$  represents the elastic stiffness tensor of each subcell  $(\alpha\beta\gamma)$  and  $d_\alpha, h_\beta, l_\gamma$  the respective subcell dimensions (see Fig. 2) wherein,

$$d = \sum_{\alpha=1}^{N_\alpha} d_\alpha \quad h = \sum_{\beta=1}^{N_\beta} h_\beta \quad l = \sum_{\gamma=1}^{N_\gamma} l_\gamma$$

Similarly, given the concentration matrices  $A^{(\alpha\beta\gamma)}$  and  $D^{(\alpha\beta\gamma)}$ , expressions for the average strain in each subcell can be constructed, i. e.,

$$\bar{\epsilon}^{(\alpha\beta\gamma)} = A^{(\alpha\beta\gamma)} \bar{\epsilon} + D^{(\alpha\beta\gamma)} (\epsilon_s^I + \epsilon_s^T)$$

as well as average stress,

$$\bar{\sigma}^{(\alpha\beta\gamma)} = C^{(\alpha\beta\gamma)} [A^{(\alpha\beta\gamma)} \bar{\epsilon} + D^{(\alpha\beta\gamma)} (\epsilon_s^I + \epsilon_s^T) - (\bar{\epsilon}^{I(\alpha\beta\gamma)} + \bar{\epsilon}^{T(\alpha\beta\gamma)})]$$

The analytic constitutive law, see eq. 1, may be readily applied to investigate the behavior of various types of composites, given knowledge of the behavior of the individual phases. Numerous advantages can be stated regarding the current macro/micro constitutive laws as compared to the other numerical micromechanical approaches in the literature, e.g. the finite element unit cell approach. One advantage is that any type of simple or combined loading (multiaxial state of stress) can be applied irrespective of whether symmetry exists or not, as well as without resorting to different boundary condition application strategies as in the case of the finite element unit cell procedure. Another, advantage concerns the

Double  
Periodicity

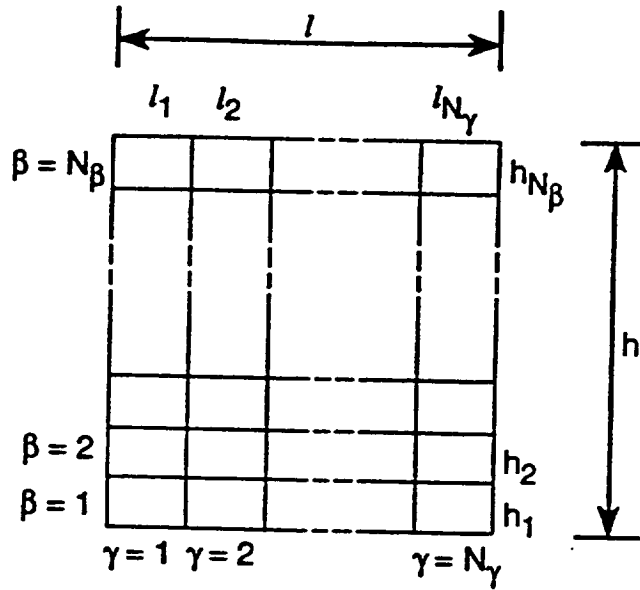

Triple  
Periodicity

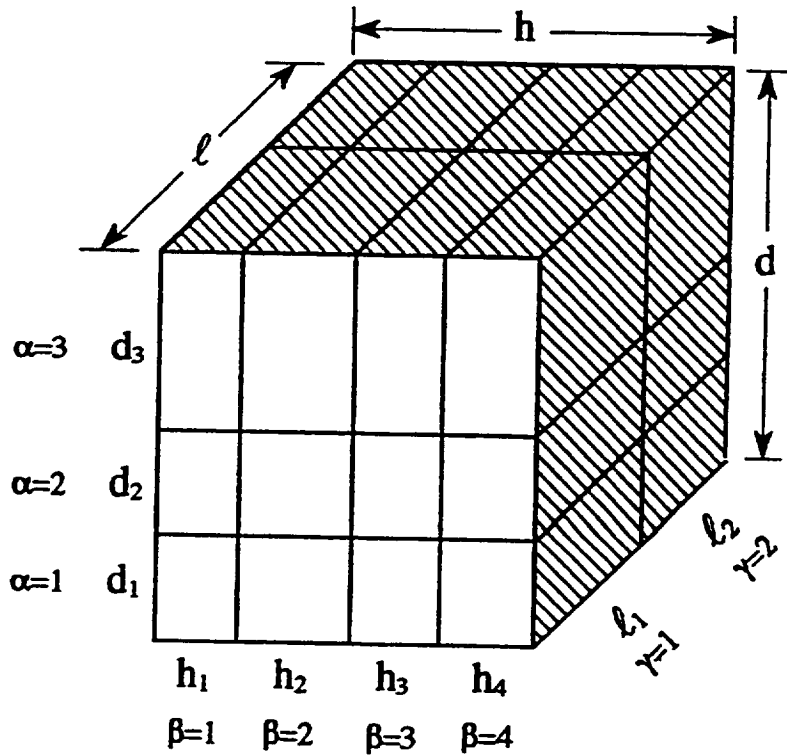

Figure 2: Subcell Dimension Nomenclature

availability of an analytical expression representing the macro elastic-thermo-inelastic constitutive law thus ensuring a reduction in memory requirements when implementing this formulation into a structural finite element analysis code. Furthermore, this formulation has been shown to predict accurate macro behavior given only a few subcells, within the repeating cell (see references [2], and [4]). Whereas, if one employs the finite element unit cell procedure, a significant number of finite elements are required within a given repeating unit cell to obtain the same level of accuracy as with the present formulation. Consequently, it is possible to utilize this formulation to efficiently analyze metal matrix composite structures subjected to complex thermomechanical load histories. This is particularly important when analyzing realistic structural components, since different loading conditions exist throughout the structure, thus necessitating the application of the macromechanical equations repeatedly at these locations.

### 3.2 Integration Algorithms

There are two integration algorithms currently available within **MAC**. The first is the standard, explicit Forward Euler algorithm, which can be expressed as,

$$w_{i+1} = w_i + \Delta t f(t_i, w_i)$$

where

$$\begin{aligned} w_i &= \underline{y}(t_i) \\ w_{i+1} &= \underline{y}(t_{i+1}) \end{aligned}$$

and  $f(t_i, w_i)$  is the rate of change with respect to time of the vector,  $\underline{y}(t_i)$ , i.e.

$$f(t_i, w_i) = \underline{\dot{y}} = \frac{d\underline{y}(t_i)}{dt}$$

The second is a predictor/corrector algorithm which uses:

- 1) a 4<sup>th</sup> order Runge-Kutta starter:

$$w_i = w_{i-1} + \frac{(K_1 + 2K_2 + 2K_3 + K_4)}{6}$$

where

$$\begin{aligned}
 K_1 &= \Delta t f(t_{i-1}, w_{i-1}) \\
 K_2 &= \Delta t f\left(t_{i-1} + \frac{\Delta t}{2}, w_{i-1} + \frac{K_1}{2}\right) \\
 K_3 &= \Delta t f\left(t_{i-1} + \frac{\Delta t}{2}, w_{i-1} + \frac{K_2}{2}\right) \\
 K_4 &= \Delta t f(t_{i-1} + \Delta t, w_{i-1} + K_3)
 \end{aligned}$$

2) with an Adams Bashforth four-step predictor:

$$\begin{aligned}
 w_0 &= \alpha_1 & w_1 &= \alpha_2 & w_2 &= \alpha_3 & w_3 &= \alpha_4 \\
 w_{i+1}^P &= w_i + \frac{\Delta t}{24} [55f(t_i, w_i) - 59f(t_{i-1}, w_{i-1}) + 37f(t_{i-2}, w_{i-2}) \\
 &\quad - 9f(t_{i-3}, w_{i-3})]
 \end{aligned}$$

and 3) an Adams Moulton four step corrector:

$$\begin{aligned}
 w_{i+1}^C &= w_i + \frac{\Delta t}{24} [9f(t_{i+1}, w_{i+1}^P) + 19f(t_i, w_i) - 5f(t_{i-1}, w_{i-1}) \\
 &\quad + f(t_{i-2}, w_{i-2})]
 \end{aligned}$$

where the  $\alpha$ 's come from the 4<sup>th</sup> order Runge-Kutta starter. Further details may be found in [6].

It has been found, based on experience, that for relatively rapid monotonic or cyclic loadings it may be more efficient to use the Forward Euler integrator since the predictor/corrector requires 5 evaluations per step, as shown above. However, in the case of creep, relaxation or slow monotonic or cyclic loading histories, significant increases in solution speeds can be obtained using the predictor/corrector algorithm with a self-adaptive time step.

Finally, within **MAC** the vector  $\underline{y}$  as used above contains the following macro quantities:

<u>position</u>	<u>contents</u>
1 - 6	Macro Total Strain
7 - 12	Macro Stress
13 - 18	Macro Inelastic Strain
19 - 30	(currently empty space for 2 6x1 vectors)
31 - 36	Macro Thermal Strain
37	Current Temperature

and the quantities associated with each subcell are stored sequentially in  $\underline{y}$ , such that

<u>position</u>	<u>contents</u>
38 - 43	Micro Total Strain
44 - 49	Micro Stress
50 - 55	Micro Inelastic Strain
56 - 67	Micro Internal State Variables (space for 2 6x1 vectors)
68 - 73	Micro Thermal Strain

The above 36 positions are repeated for the total number of (N) subcells thus bringing the total length of the  $\underline{y}$  vector to 37+36N. It follows that a second vector of similar length contains the corresponding macro and micro rates  $\dot{\underline{y}}$ .

### 3.3 Available Constituent Constitutive Models

Currently **MAC** provides one elastic and four inelastic constitutive models. These models have been selected purely based upon the availability of material parameters for the materials of interest. However, **MAC** is designed in a modular fashion thus allowing the implementation of additional constitutive models through a user defined subroutine. Two of the four available inelastic models are capable of representing transversely isotropic material behavior, thus allowing one to investigate the reinforcement of an anisotropic matrix or the idealization of an anisotropic fiber. In all four inelastic models a purely elastic response is possible by modifying a single material parameter for each model as noted below.

### 3.3.1 Elastic Model

**Reference:** Mechanics of Composite Materials, Jacob Aboudi, Elsevier, 1991

The following transversely isotropic model is provided for those materials that have an elastic only response, such as the fiber constituent in a composite.

$$\begin{bmatrix} \sigma_{11} \\ \sigma_{22} \\ \sigma_{33} \\ \sigma_{23} \\ \sigma_{13} \\ \sigma_{12} \end{bmatrix} = \begin{bmatrix} C_{11} & C_{12} & C_{12} & 0 & 0 & 0 \\ C_{12} & C_{22} & C_{23} & 0 & 0 & 0 \\ C_{12} & C_{23} & C_{22} & 0 & 0 & 0 \\ 0 & 0 & 0 & C_{44} & 0 & 0 \\ 0 & 0 & 0 & 0 & C_{44} & 0 \\ 0 & 0 & 0 & 0 & 0 & C_{66} \end{bmatrix} \begin{bmatrix} \varepsilon_{11} \\ \varepsilon_{22} \\ \varepsilon_{33} \\ \gamma_{23} \\ \gamma_{13} \\ \gamma_{12} \end{bmatrix}$$

where components  $C_{ij}$  can be expressed in terms of five independent constants,

$$E_A, E_T, \nu_A, \nu_T, G_A$$

thus,

$$C_{11} = E_A + 4\kappa\nu_A^2$$

$$C_{12} = 2\kappa\nu_A$$

$$C_{22} = \kappa + \frac{0.5E_T}{(1 + \nu_T)}$$

$$C_{23} = \kappa - \frac{0.5E_T}{(1 + \nu_T)}$$

$$C_{44} = G_A$$

$$C_{66} = \frac{(C_{22} - C_{23})}{2}$$

### 3.3.2 Bodner-Partom Model

**Reference:** Mechanics of Composite Materials, Jacob Aboudi, Elsevier, 1991

This model represents the Bodner-Partom viscoplastic model with isotropic hardening,  $Z$ , and can be used for an initially isotropic metallic material.

The flow law is given as:

$$\dot{\epsilon}_{ij}^I = \Lambda s_{ij}$$

where

$$\Lambda = \sqrt{\frac{D_2^{PL}}{J_2}}$$

$$D_2^{PL} = D_0^2 \exp\left[-\left(\frac{A^2}{J_2}\right)^n\right]$$

$$A^2 = \frac{1}{3} Z_{eff}^2 \left(\frac{n+1}{n}\right)^{\frac{1}{n}}$$

$$J_2 = \frac{1}{2} s_{ij} s_{ij}$$

$$s_{ij} = \sigma_{ij} - \frac{1}{3} \sigma_{kk} \delta_{ij}$$

The evolution law for isotropic hardening is given as:

$$\dot{Z} = m(Z_1 - Z_{eff}) \frac{\dot{W}^{PL}}{Z_0}$$

where  $Z_0$ ,  $Z_1$  and  $m$  are inelastic constants and the plastic work rate,  $\dot{W}^{PL}$ , is given by;

$$\dot{W}^{PL} = \sigma_{ij} \dot{\epsilon}_{ij}^I$$

$$Z_{eff} = Z_0 + q \int_0^t \dot{Z}(\tau) d\tau + (1-q) \sum_{i,j=1}^3 r_{ij} \int_0^t \dot{Z}(\tau) r_{ij}(\tau) d\tau$$

$$r_{ij}(t) = \sigma_{ij}(t) / [\sigma_{kl}(t) \sigma_{kl}(t)]^{1/2}$$

An elastic only response may be obtained by setting the material parameter  $D_0$  to zero.



### 3.3.3 Robinson Creep Model

Reference: NASA TM 103172, 1990

This model represents a transversely isotropic material, wherein the vector of direction cosines,  $d_i$  defines the strong material direction along which no inelasticity occurs.

Flow Law:

$$\frac{\dot{\epsilon}_{ij}^I}{\dot{\epsilon}_0} = 2F^n \frac{\Gamma_{ij}}{\sigma_0 \sqrt{F}}$$

Evolution Law:

$$\dot{a}_{ij} = \frac{H}{G^\beta} \frac{1}{2} \frac{\dot{\epsilon}_{ij}^I}{\dot{\epsilon}_0} - R G^{m-\beta} \frac{\Pi_{ij}}{\sigma_0 \sqrt{G}}$$

where

$$\Gamma_{ij} = \Sigma_{ij} - \frac{1}{2} I (3D_{ij} - \delta_{ij})$$

$$\Pi_{ij} = a_{ij} - \frac{1}{2} \hat{I} (3D_{ij} - \delta_{ij})$$

in which

$$F = \frac{4}{\sigma_0^2} \phi \quad \phi = J_2 - \frac{3}{4} I^2$$

$$G = \frac{4}{\sigma_0^2} \psi \quad \psi = \hat{J}_2 - \frac{3}{4} \hat{I}^2$$

and

$$J_2 = \frac{1}{2} \Sigma_{ij} \Sigma_{ji} \quad I = D_{ij} \Sigma_{ji} \quad D_{ij} = d_i d_j \quad \Sigma_{ij} = S_{ij} - a_{ij}$$

$$\hat{J}_2 = \frac{1}{2} a_{ij} a_{ji} \quad \hat{I} = D_{ij} a_{ji} \quad S_{ij} = \sigma_{ij} - \frac{1}{3} \sigma_{kk} \delta_{ij}$$

Special cases involving an isotropic material can be obtained by defining  $d_i = (1/3, 1/3, 1/3)$  and/or elastic only response by setting  $\sigma_0$  to an extremely large number.

### 3.3.4 Robinson Viscoplastic Model

Reference: NASA TM 105819, 1992

This model represents a transversely isotropic material wherein the vector of direction cosines  $d_i$  defines the preferred material direction. In this model the strength of anisotropy is specified by the parameters  $\omega$  and  $\eta$ ; where  $\omega$  is the ratio of the normal longitudinal and transverse yield stress and  $\eta$  is the ratio of longitudinal and transverse shear strengths.

Flow Law:

$$\dot{\epsilon}_{ij}^I = \frac{\langle F^n \rangle}{2\mu} \Gamma_{ij}$$

Evolution Law

$$\dot{a}_{ij} = \frac{H}{G^\beta} \dot{\epsilon}_{ij}^I - RG^{m-\beta} \Pi_{ij}$$

where

$$\Gamma_{ij} = \Sigma_{ij} - \xi(D_{ki}\Sigma_{jk} + D_{jk}\Sigma_{ki} - 2I_0D_{ij}) - \frac{1}{2}\zeta I_0(3D_{ij} - \delta_{ij})$$

$$\Pi_{ij} = a_{ij} - \xi(D_{ki}a_{jk} + D_{jk}a_{ki} - 2\hat{I}_0D_{ij}) - \frac{1}{2}\zeta\hat{I}_0(3D_{ij} - \delta_{ij})$$

and

$$F = \frac{1}{\kappa_T} \left[ I_1 + \frac{1}{\eta^2} I_2 + \frac{9}{4(4\omega^2 - 1)} I_3 \right]^{-1}$$

$$\hat{G} = \frac{1}{\kappa_T^2} \left[ \hat{I}_1 + \frac{1}{\eta^2} \hat{I}_2 + \frac{9}{4(4\omega^2 - 1)} \hat{I}_3 \right]$$

$$G = \langle \hat{G} - \hat{G}_0 \rangle H\nu[S_{ij}\pi_{ij}] + \hat{G}_0$$

$$I_1 = J_2 - I - \frac{1}{4}I_3 \quad I_2 = I - I_3 \quad I_3 = I_0^2$$

$$J_2 = \frac{1}{2}\Sigma_{ij}\Sigma_{ji} \quad I = D_{ij}\Sigma_{ji} \quad D_{ij} = d_id_j \quad \Sigma_{ij} = S_{ij} - a_{ij}$$

$$\xi = \frac{\eta^2 - 1}{\eta^2} \quad \zeta = \frac{4(\omega^2 - 1)}{4\omega^2 - 1}$$

The invariants  $\hat{I}_1, \hat{I}_2, \hat{I}_3$  are the same as those given above but with  $\Sigma_{ij}$  replaced by  $a_{ij}$ . Special cases involving an isotropic material and/or elastic only response can be obtained by defining  $\omega = \eta = 1$  and/or by setting  $\kappa_T$  to an extremely large number.

### 3.3.5 Generalized Viscoplastic Potential Structure (GVIPS) Model

Reference: NASA TM 106609, 1994

This model is a fully associative, multiaxial, isothermal, nonlinear kinematic hardening viscoplastic model for use with initially isotropic metallic materials. A unique aspect of this model is the inclusion of non-linear hardening through the use of a compliance operator  $Q_{ijkl}$  in the evolution law for the back stress. This non-linear tensorial operator is significant in that it allows both the flow and evolutionary laws to be fully associative (and therefore easily integrated) and greatly influences the multiaxial response under non-proportional loading paths.

Flow Law:

$$\dot{\epsilon}_{ij}^I = \frac{3}{2} \|\dot{\epsilon}_{ij}^I\| \frac{\Sigma_{ij}}{\sqrt{J_2}} \quad \text{if} \quad F \geq 0$$

where

$$\|\dot{\epsilon}_{ij}^I\| = \sqrt{\frac{2}{3} \dot{\epsilon}_{ij}^I \dot{\epsilon}_{ij}^I} = \frac{\mu F^n}{\kappa}$$

Internal constitutive rate equation

$$\dot{a}_{ij} = L_{ijrs} \dot{A}_{rs}$$

Evolution Law:

$$\dot{A}_{rs} = \dot{\epsilon}_{rs}^I - \frac{3\beta}{2\kappa} \|\dot{\epsilon}_{ij}^I\| \frac{a_{rs}}{\sqrt{G}} H\nu[Y] - \frac{3R_\alpha B_0 G^q}{\kappa^2} a_{rs} \quad \text{if} \quad a_{ij} \Sigma_{ij} \geq 0$$

$$\dot{A}_{rs} = Q_{rslm} E_{lmnp} \left( \dot{\epsilon}_{np}^I - \frac{3\beta}{2\kappa} \|\dot{\epsilon}_{ij}^I\| \frac{a_{np}}{\sqrt{G}} H\nu[Y] - \frac{3R_\alpha B_0 G^q}{\kappa^2} a_{np} \right) \quad \text{if} \quad a_{ij} \Sigma_{ij} < 0$$

where

$$F = \left\langle \frac{\sqrt{J_2}}{\kappa} - Y \right\rangle$$

$$Y = \langle 1 - \beta\sqrt{G} \rangle$$

$$G = \frac{I_2}{\kappa^2}$$

$$L_{ijrs} = [Q_{ijrs}]^{-1} = \frac{\kappa^2}{3B_0(1 + B_1pG^{p-1})} \left( I_{ijrs} - \frac{3B_1(p-1)G^{p-2}}{\kappa^2(1 + B_1pG^{p-1})(6p-5)} a_{rs}a_{ij} \right)$$

and

$$I_2 = \frac{3}{2}a_{ij}a_{ij} \quad \Sigma_{ij} = S_{ij} - a_{ij}$$

$$J_2 = \frac{3}{2}\Sigma_{ij}\Sigma_{ij} \quad S_{ij} = \sigma_{ij} - \frac{1}{3}\sigma_{kk}\delta_{ij}$$

The special case of an elastic only response maybe obtained by setting  $\kappa$  to an extremely large value.

### 3.4 Laminate Theory

Version 2.0 of **MAC** now includes the capability to analyze composite laminates. In-plane axial displacements and membrane forces may be applied to the laminate. That is, the global laminate stress-strain relation that is solved within **MAC** is expressed as,

$$\begin{bmatrix} \bar{N}_{XX} \\ \bar{N}_{YY} \\ \bar{N}_{XY} \end{bmatrix} = \begin{bmatrix} A_{11} & A_{12} & A_{13} \\ A_{21} & A_{22} & A_{23} \\ A_{31} & A_{32} & A_{33} \end{bmatrix} \begin{bmatrix} \bar{\epsilon}_{xx} \\ \bar{\epsilon}_{yy} \\ \bar{\epsilon}_{xy} \end{bmatrix} - \begin{bmatrix} \bar{N}_{XX}^I \\ \bar{N}_{YY}^I \\ \bar{N}_{XY}^I \end{bmatrix} - \begin{bmatrix} \bar{N}_{XX}^T \\ \bar{N}_{YY}^T \\ \bar{N}_{XY}^T \end{bmatrix} \quad (\text{EQ 11})$$

or

$$\bar{N} = \underline{A} \bar{\epsilon} - \bar{N}^I - \bar{N}^T \quad (\text{EQ 12})$$

where  $\bar{N}$ ,  $\bar{N}^I$ , and  $\bar{N}^T$  are the global laminate total, inelastic and thermal stress resultants, respectively. The matrix  $\underline{A}$  is the global laminate stiffness and  $\bar{\epsilon}$  the global laminate strains.

In forming the laminate stiffness  $\underline{A}$  the generalized method of cells model, GMC, is utilized to calculate the individual lamina properties. In this regard, the individual laminate stiffness, in lamina coordinates,  $\underline{Q}$  is given by,

$$\underline{Q} = \begin{bmatrix} Q_{11} & Q_{12} & 0 \\ Q_{21} & Q_{22} & 0 \\ 0 & 0 & Q_{66} \end{bmatrix} \quad (\text{EQ 13})$$

in which the components of  $\underline{Q}$  are given as,

$$\begin{aligned} Q_{11} &= C_{11} - \frac{C_{13}C_{31}}{C_{33}} & Q_{12} &= C_{12} - \frac{C_{13}C_{23}}{C_{33}} \\ Q_{22} &= C_{22} - \frac{C_{23}C_{32}}{C_{33}} & Q_{33} &= C_{66} \end{aligned} \quad (\text{EQ 14})$$

The  $C_{ij}$  in the above are the **effective macro** properties for the unidirectional composite lamina obtained from GMC.

It follows that the lamina stress-strain relation in global (laminate) coordinates is given by the relation,

$$\begin{bmatrix} \sigma_x \\ \sigma_y \\ \sigma_{xy} \end{bmatrix}_k = \begin{bmatrix} \bar{Q}_{11} & \bar{Q}_{12} & \bar{Q}_{13} \\ \bar{Q}_{12} & \bar{Q}_{22} & \bar{Q}_{23} \\ \bar{Q}_{13} & \bar{Q}_{23} & \bar{Q}_{33} \end{bmatrix}_k \begin{bmatrix} \varepsilon_x \\ \varepsilon_y \\ \varepsilon_{xy} \end{bmatrix}_k \quad (\text{EQ 15})$$

or

$$\bar{\sigma} = \bar{Q} \bar{\varepsilon} \quad (\text{EQ 16})$$

where

$$\bar{Q} = R^{-1} Q R \quad (\text{EQ 17})$$

$$R = \begin{bmatrix} \cos^2 \theta & \sin^2 \theta & 2 \sin \theta \cos \theta \\ \sin^2 \theta & \cos^2 \theta & (-2) \sin \theta \cos \theta \\ -\sin \theta \cos \theta & \sin \theta \cos \theta & \cos^2 \theta - \sin^2 \theta \end{bmatrix} \quad (\text{EQ 18})$$

and  $\theta$  is the orientation of the longitudinal lamina axis with respect to the global  $x$  direction, thus  $\bar{Q}_k$  is the transformed lamina stiffness, i.e. from local lamina to global laminate coordinates. In addition,  $\bar{\sigma}$  and  $\bar{\varepsilon}$  are the lamina stress and strain in laminate coordinates. It then follows that the global laminate stiffness  $\underline{A}$  is given by,

$$\underline{A} = \sum_{k=1}^{nly} \bar{Q}_k t_k \quad (\text{EQ 19})$$

in which  $nly$  is the total number of layers in the laminate and  $t_k$  is the thickness of the  $k^{th}$  lamina.

Returning to EQ. 12, the quantities  $\bar{N}^I$  and  $\bar{N}^T$  (the laminate inelastic and thermal stress resultants, respectively) are calculated from the individual lamina contributions through the following relations,

$$\bar{V}^I = \sum_{k=1}^{nly} \bar{N}_k^I t_k \quad \bar{N}^T = \sum_{k=1}^{nly} \bar{N}_k^T t_k \quad (\text{EQ 20})$$

The individual lamina stress resultants  $\bar{N}_k^I$  and  $\bar{N}_k^T$  are given by,

$$\bar{N}_k^I = \bar{Q}_k \bar{\varepsilon}_k^I \quad (\text{EQ 21})$$

**for the inelastic strains and**

$$\tilde{N}^T = \tilde{Q}_k \varepsilon_k^T \quad (\text{EQ 22})$$

**for the thermal strains.**



### 3.5 User Defined Material Model

Another addition to version 2.0 of *MAC*, is the option for a user to implement their own constitutive model. This is accomplished by using the subroutine USRMAT into which the user writes the necessary FORTRAN code for the particular constitutive model being implemented. The USRMAT subroutine is as shown below.

#### USRMAT

```

C#####
SUBROUTINE USRMAT(DSA,SA,PE,PV,
& TIME,TSTEP,CTEMP,DTEMPR,TREF,NIO,NPE,NPV,NCE)
C
C purpose: user supplied constitutive model
C
C note: 1) in this subroutine, [sa] and [dsa] contain the
C "micro" quantities for aboudi's micromechanics model
C
C 2) arrangement of [dsa] & [sa] arrays are as follows
C
C variable location
C
C -----
C | strain rate (1-6)
C |-----
C | stress rate (7-12)
C |-----
C | inelastic
C | strain rate (13-18)
C |-----
C | 12 "slots" (19-30)
C | for state variables
C |-----
C | thermal strain rate (31-36)
C |-----
C
C IMPLICIT DOUBLE PRECISION (A-H,O-Z)
C
C DIMENSION DSA(36),SA(36),PE(NPE),PV(NPV)
C-----start user supplied material routine -----C
C
C place code defining model here
C
C-----end of user supplied material routine-----C
RETURN
END
    
```

A description of the input and output required for the usrmat subroutine is as follows

Program data available to USRMAT:

SA	array containing current total quantities for all of the state variables
PE	array containing elastic constants
PV	array containing inelastic constants
TIME	current time
TSTEP	current time increment (step)
CTEMP	current temperature
DTEMPR	current temperature rate
TREF	reference temperature
NPE	total number of elastic constants
NPV	total number of inelastic constants
NIO	output file unit number
NCE	current subcell number

Output expected from USRMAT:

DSA	current increments in all state variables
-----	-------------------------------------------

The state variables are arranged in SA and DSA in the following order:

Position	Quantity
1-6	strain
7-12	stress
13-18	inelastic strain
19-30	available space for 2 6x1 vectors for model dependent internal state variables
31-36	thermal strain

Again, SA contains the total quantities and DSA contains the rates.

**Note:** Appendix H contains a sample input file and the USRMAT subroutine containing an implementation of the Bodner-Partom viscoplastic material model.

### 3.6 Interface Modeling

Interfaces in composite materials play a major role in the determination of their mechanical and thermal properties. Consequently, it is important to have the ability to model interface behavior accurately. This is accomplished in MAC/GMC in one of two ways. The first is to define an actual interface region with its own constitutive behavior. In this way the influence of initial imperfections (flaws, voids, improper wetting, etc.) and induced interfacial damage (due to stress, environment, chemical reactions, etc) may be incorporated into the micromechanical analysis of the overall behavior of the composite. The development of proper interfacial constitutive models is an active area of research and MAC, through the use of its USRMAT routine, provides the researcher with a convenient tool for testing new and existing interfacial constitutive models.

The second approach to modeling the effect of imperfect (weak) bonding between two phases (e.g. a fiber and matrix) is to assume a jump in the displacement field at a particle-matrix interface may occur given certain conditions, while still maintaining continuity of the traction vector. In the spirit of Jones and Whittier (see ref. 10) and Achenbach and Zhu (see ref. 11) we have assumed the following "elastic-perfectly plastic" flexible interface model.

$$\begin{bmatrix} (\dot{u}_n^I = R_n \cdot \dot{\sigma}_n^I) \\ (\dot{u}_t^I = R_t \cdot \dot{\sigma}_t^I) \end{bmatrix} \quad \text{if} \quad \begin{bmatrix} \sigma_n^I \geq \sigma_{DBn} \\ \sigma_t^I \geq \sigma_{DBt} \end{bmatrix} \quad (\text{EQ 23})$$

$$\begin{bmatrix} (\dot{u}_n^I = 0) \\ (\dot{u}_t^I = 0) \end{bmatrix} \quad \text{if} \quad \begin{bmatrix} \sigma_n^I < \sigma_{DBn} \\ \sigma_t^I < \sigma_{DBt} \end{bmatrix} \quad (\text{EQ 24})$$

where  $R_n, R_t, \sigma_{DBn}$  and  $\sigma_{DBt}$  are the interfacial normal and shear, strength and debond stress, respectively. Implementation of this model impacts the definition of the concentration matrices,  $A^{(\alpha\beta\gamma)}$  discussed in **section 3.1**.

### 3.7 References

- 1) Aboudi, J.; Mechanics of Composite Materials: A Unified Micromechanical Approach, Elsevier, Amsterdam, 1991.
- 2) Paley, M., and Aboudi, J.; "Micromechanical Analysis of Composites by the Generalized Method of Cells Model", *Mechanics of Materials*, Vol. 14, pp 127-139, 1992.
- 3) Aboudi, J.; "Micromechanical Analysis of Thermo-Inelastic Multiphase Short-Fiber Composites", NASA CR 195290, 1994.
- 4) Arnold, S.M., Wilt, T.E., Saleeb, A.F., and Castelli, M.G., "An Investigation of Macro and Micromechanical Approaches for a Model MMC System", NASA CP 19117, Vol. II, pp. (52.1) - (52.12), 1993.
- 5) Arnold, S.M., Wilt, T.E., and Pindera, M.J., "Influence of Fiber Architecture on the Elastic and Inelastic Response of Metal Matrix Composites", NASA TM 106705, 1994.
- 6) Burden, R.L. and Faires, J.D.; Numerical Analysis, Prindle, Weber and Schmidt, 1985.
- 7) W.K. Binienda, D.N. Robinson, S.M. Arnold, and P.A. Bartolotta, "A Creep Model for Metallic Composites Based on Matrix Testing: Application to Kanthal Composites", NASA TM 103172, 1990.
- 8) S.M. Arnold, D.N. Robinson, and P.A. Bartolotta, "Unified Viscoplastic Behavior of Metal Matrix Composites", NASA TM 105819, 1992.
- 9) S.M. Arnold, A.F. Saleeb, and M.G. Castelli, "A Fully Associative, Non-Linear Kinematic, Unified Viscoplastic Model for Titanium Based Matrices", NASA TM 106609, 1994.
- 10) J.P. Jones and J.S. Whittier, *J. Appl. Mech.* Vol. 34, pg. 905, 1967.
- 11) J.D. Achenbach and H. Zhu, *J. Mech. Phys. Solids*, Vol. 37, pg. 381, 1989

## 4.0 Running MAC

MAC has been developed for a Sun IPX workstation running Sun Solaris. Upon linking the associated object modules that comprise *MAC*, execution is begun by simply typing MAC (in upper case) and hitting return.

### 4.1 Input and Output Files

MAC requires that the names of the input and output files be specified. The user is prompted for the names of the input, *infile*, and output file, *outfile*, and the names of the input and output files may be anything the user desires. As will be explained in the following sections, the user will also need to specify the names of the PATRAN output files and the files containing the X-Y data for plotting.

Note that a “debug” file may be generated depending on the “PRINT” level the user specifies in the input file (see 4.2.2). This file will have the same name as the output file but with the string “\_debug” automatically appended at the end of the filename, i.e., *outfile\_debug*.

<u>Input</u>	<u>Output</u>
<i>infile</i>	<i>outfile</i>
	debug file ( <i>outfile_debug</i> )
	PATRAN files (optional, see section 4.2.11)
	plot data files (see section 4.2.15)

### 4.2 Input Requirements

This section describes how the data should appear in the input file, *infile*. In the following, each block of input data will have its own subsection and will typically contain the following information:

- 1) statement of purpose
- 2) declaration of input data block
- 3) example(s)
- 4) notes

A data block has the following general format:

- |                  |                         |
|------------------|-------------------------|
| 1) *keyword      | beginning of data block |
| 2) input line(s) |                         |
| 3) %             | end of data block       |

where

1) \*keyword: (denotes beginning of data block)

Each input data block begins with the appropriate keyword, which starts with the \* symbol. For example, the keyword for selecting the method of integration is \*SOLVER. The input routine scans the input file and locates the appropriate keyword and then reads the corresponding input data

2) Input line(s):

The input lines contain the necessary input data. The specific format of these input lines will be given in the next section.

Two special characters (& and #) are provided for entering the input.

The "&" (continuation) symbol:

For input data that is too long to fit on a single line, the "&" symbol is used as the continuation character. Thus, a line of data may be divided into a series of lines. For example, when entering the material properties all of the data cannot fit on a single line, thus the continuation character is required:

```
EL=11700.,11700.,0.365,0.365,4287.5,1.,1. &  
VI=0.8E-8,0.1,0.1E-5,0.,0.85E-3,0.05,1.,1.,1.,3.3,1.8,1.35,1.,0.01
```

The "#" (comment) symbol:

The input file may also contain "comments" for the users convenience. The "#" symbol is used to mark a comment line, with the requirement that the "#" symbol appears in the first column.

3) % (denotes end of data block)

Each input block ends with the "%" symbol. The % symbol **must be** included as it signals the input routine that a particular data block has been completed.

A sample data block is as follows,

```
*SOLVER  
# NTF=2 ISTM=0.0001 ERR=0.1E-3  
NTF=2 ISTM=0.000024 ERR=0.1E-2 %
```

Note how the # symbol is used to comment out a line of input data. Thus, the user can change various parameters by simply commenting out input lines containing different input data. Also note how the data block is terminated with the % symbol and how it need not appear on a separate line.

☞ **Note:** It is suggested that the order of keywords in a given input file follow that given in this manual.:

#### **4.2.1 Header Line:**

Purpose: Define the title of this particular job (80A format).

☞ **Note:** the **Header Line** is limited to one 80 character line, and is always taken as the first line in the input file.:

*problem title*

**Example:**        Transverse tensile response of 35% SCS6/Ti--6-4

#### **4.2.2 Output Print Level:**

Purpose: To control the output generated

**\*PRINT**  
NPL=*nplvl*

%

Where

*nplvl:*

-1 = print out macro stiffness matrix, engineering constants and macro thermal expansion coefficients

0 = minimal output (most commonly used)

7 = basic program trace

10 = *program execution trace and all array data*

**WARNING:** *this generates a very large output file*

**Example:** (minimal print out)

**\*PRINT**  
NPL=0 %

### **4.2.3 Load Type:**

Purpose: To select load type

```
*LOAD  
    LCON=nse1   LOP=lop   LSS=iopt
```

%

Where

*nse1*:

- 1 = Thermal Load
- 2 = Mechanical Load
- 3 = Thermomechanical Load

*lop*: (for 2-D and 3-D GMC)

- |                               |                             |
|-------------------------------|-----------------------------|
| 1 = axial load in 1-direction | 4 = shear load 23-direction |
| 2 = axial load in 2-direction | 5 = shear load 13-direction |
| 3 = axial load in 3-direction | 6 = shear load 12-direction |

For 2-D GMC:

- 7 = axial loads in 1 and 2 directions
- 8 = axial loads in 2 and 3 directions
- 9 = axial load in 1-direction and shear load in 23-direction
- 10 = axial load in 2-direction and shear load in 13-direction

For 3-D GMC:

- 7 = axial loads in 1 and 2 directions
- 8 = axial loads in 2 and 3 directions
- 9 = axial loads in 1 and 3 directions
- 10 = axial load in 1-direction and shear load in 23-direction
- 11 = axial load in 2-direction and shear load in 13-direction
- 12 = axial load in 3-direction and shear load in 12-direction

*iopt*:

- 1 = Strain control
- 2 = Stress control



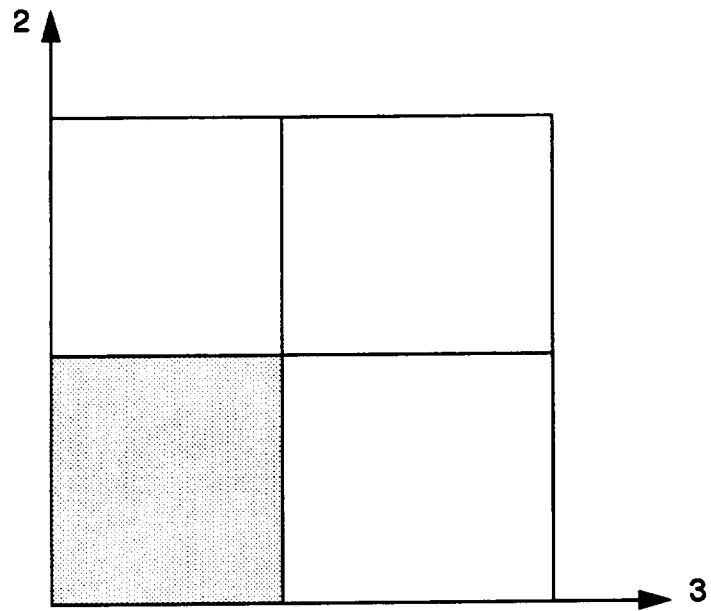

Double Periodicity

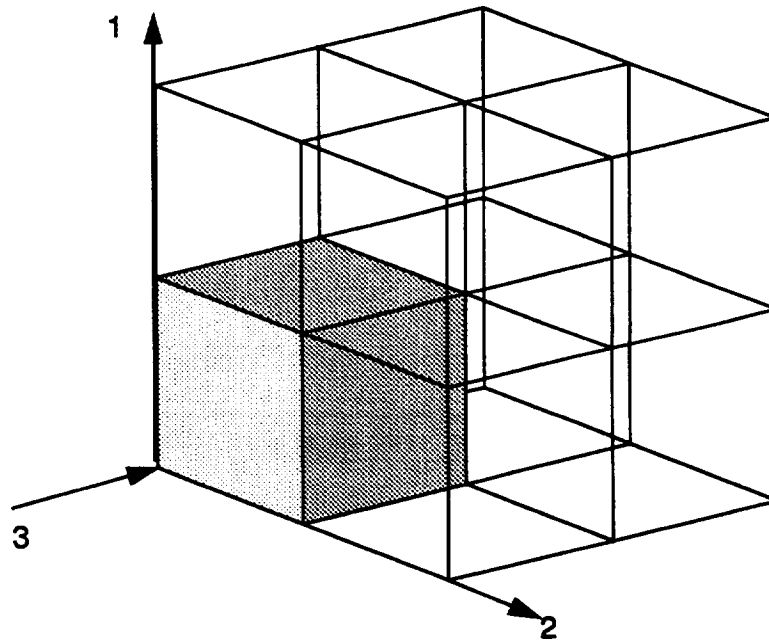

Triple Periodicity

Figure 3: Coordinate Systems

#### 4.2.4 Mechanical Load Control:

☞ **Note:** This block is only required if LCON = 2 or 3

Purpose: Select type of load control for mechanical load

**\*MECH**

NPTW= $n_{ptw}$  TI= $t_1, t_2, \dots, t_{n_{ptw}}$  LO= $l_1, l_2, \dots, l_{n_{ptw}}$

%

Where

$n_{ptw}$ : number of points on load curve

$t_1, t_2, \dots, t_{n_{ptw}}$ : time values

$l_1, l_2, \dots, l_{n_{ptw}}$ : load curve values

**Example:**

**\*MECH**

NPTW=3 TI=0., 1., 2. LO=0., 20., 30. %

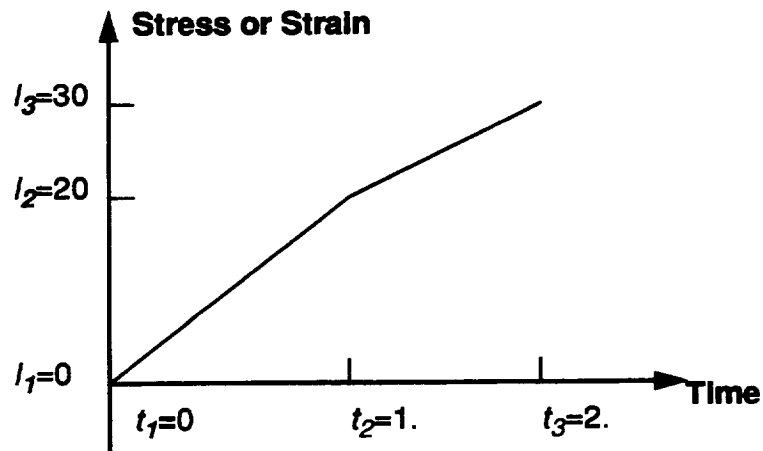

☞ **Note:** For LOP=7,8,...etc (i.e. two load/displacement components) the following format is required:

**\*MECH**

NPTW=2 TI=0., 1.5 LO=0., 0.015

component 1 curve

NPTW=2 TI=0., 1.5 LO=0., 0.01 %

component 2 curve

(See Appendix G for an example)

### 4.2.5 Temperature Control:

Note: This block is only required if LCON = 1 or 3

Purpose: Select control for temperature

**\*THERM**

NPTT= $n_{ptt}$  TI= $t_1, t_2, \dots, t_{n_{ptw}}$  TE=  $te_1, te_2, \dots, te_{n_{ptt}}$

%

Where

$n_{ptt}$ : number of points on temperature curve

$t_1, t_2, \dots, t_{n_{ptw}}$ : time values

$te_1, te_2, \dots, te_{n_{ptt}}$ : temperature curve values

**Example:**

**\*THERM**

NPTT=3 TI=0., 1., 2. TE=100., 200., 150. %

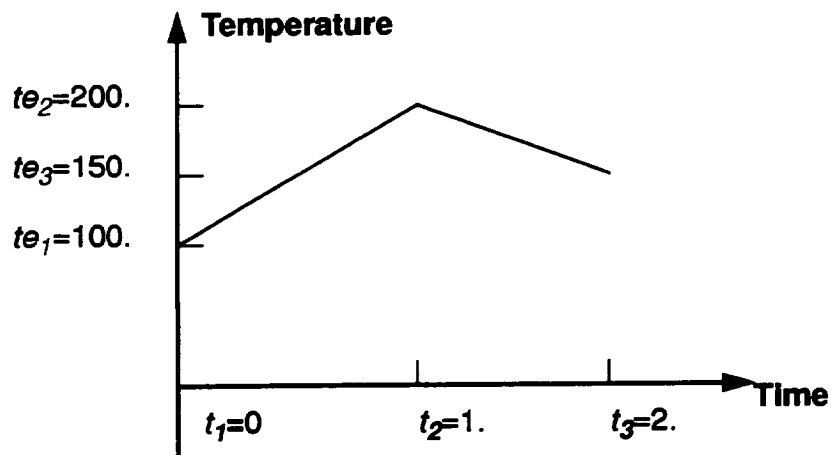

Note: For the Thermomechanical Load  $t_{nptw} \equiv t_{nptt}$ , and both curves must have  $t_1 \equiv 0$ . But the number and time value of the data points in-between maybe different, see figure 4.

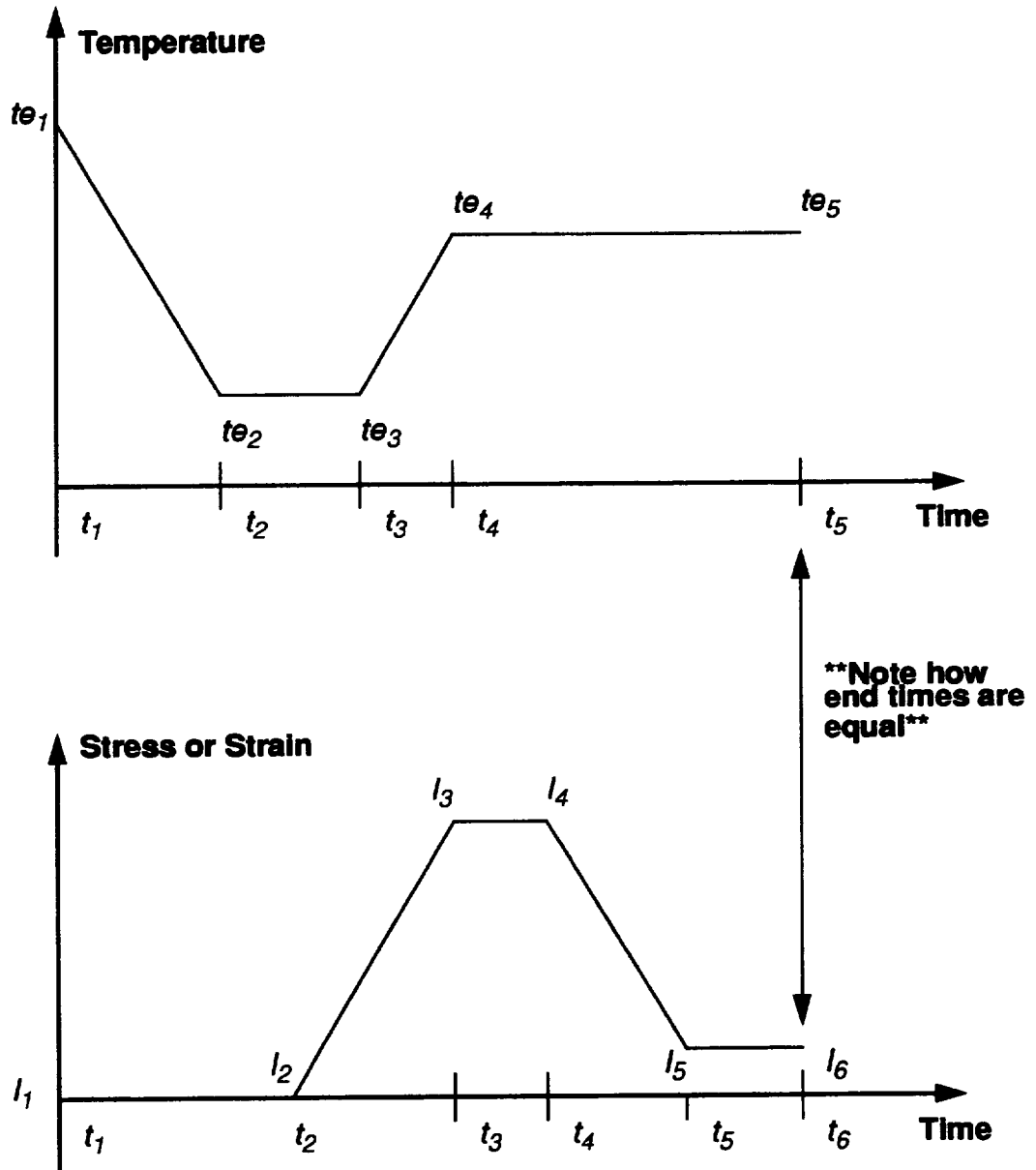

Figure 4: Load History Specification

#### **4.2.6 Reference Temperature:**

Purpose: Define initial (starting) temperature

**\*TREF**  
TREF=*tref*

%

Where

*tref*:  
--- temperature

**Example:** (set reference temperature at 70.)

**\*TREF**  
TREF=70. %

- ☞ **Note:** only important in thermal or thermomechanical load case when using secant values of coefficient of thermal expansion.
- ☞ **Note:** Units must be consistent with selected material model parameter units

#### 4.2.7 Micromechanics Model Identification:

Purpose: Select desired GMC micromechanics model

**\*MODEL**

MOD=*modid* MATSYS=*matsys*

☞ **Note:** If *modid*=3 (laminated option) you must enter the following line of data,  
 NLY=*nly* THK=*thk<sub>1</sub>, thk<sub>2</sub>, ..., thk<sub>nly</sub>* CON=*c<sub>1</sub>, c<sub>2</sub>, ..., c<sub>nly</sub>* SYS=*s<sub>1</sub>, s<sub>2</sub>, ..., s<sub>nly</sub>*  
 ANG=*a<sub>1</sub>, a<sub>2</sub>, ..., a<sub>nly</sub>*

%

Where

*modid*:

- 1 = double periodicity
- 2 = triple periodicity
- 3 = laminated option

*matsys*: - number of different material systems in the analysis

☞ **Note:** *matsys* is required only for laminated option (MOD=3)

*nly*: - number of layers in the laminated

*thk<sub>1</sub>, thk<sub>2</sub>, ..., thk<sub>nly</sub>*: - thickness of each layer

*c<sub>1</sub>, c<sub>2</sub>, ..., c<sub>nly</sub>*: - layer material type id: 1 = isotropic 2 = anisotropic

*s<sub>1</sub>, s<sub>2</sub>, ..., s<sub>nly</sub>*: - material system id number

*a<sub>1</sub>, a<sub>2</sub>, ..., a<sub>nly</sub>*: - angles of each layer

**Example 1:**

double periodicity model

**\*MODEL**

MOD=1 %

**Example 2:**

laminated option with 1 material system

**\*MODEL**

MOD=3 MATSYS=1 NLY=4 THK=0.25,0.25,0.25,0.25 CON=2,2,2,2 &  
 SYS=1,1,1,1 ANG=45.,-45.,-45.,45. %

#### 4.2.8 PATRAN Output: (Optional)

Purpose: To select PATRAN output file generation.

**\*PATRAN**

FN=*prefix* STP=*npstp* STO=*s<sub>1</sub>,s<sub>2</sub>,...s<sub>npstp</sub>*

%

Where

*prefix*:

--- this will be the filename prefix that will be assigned to all PATRAN files.

*npstp*:

the number of steps to be stored for plotting

*s<sub>1</sub>,s<sub>2</sub>,...s<sub>npstp</sub>*:

step numbers at which data is to be stored

☞ **Note: This is an optional input line.** If no PATRAN files are desired, do not include this data block.

**Example 1:** (select PATRAN output, use file prefix "run1")

**\*PATRAN**

fn=run1 STP=3 STO=1,50,100 %

☞ **Note:** If this option is chosen, **MAC** generates the following PATRAN files: (all files are written in PATRAN 2.5 neutral file format in which the subcells are treated as "elements")

- 1) ***prefix.patgeo***: contains "geometry" information of the RVE.
- 2) ***prefix.patstr***: contains micro-stress quantities  
(file is formatted as a PATRAN 2.5 element results file)
- 3) ***prefix.patepsin***: contains micro-inelastic strain quantities
- 4) ***prefix.patepsto***: contains micro-total strain quantities

For **Example 1**, the following files would be produced:

**run1.patgeo  
run1.patstr  
run1.patepsin  
run1.patepsto**

and will contain data for load steps 1, 50, and 100

#### **4.2.9 Integrator Identification**

Purpose: Select type of integration scheme

**\*SOLVER**

NTF=*ntf*

If NTF=1, enter the following line

NPTS=*npts* TIM=  $t_1, t_2, \dots, t_{npts}$  STP= $st_1, st_2, \dots, st_{npts-1}$

If NTF=2, enter the following line

ISTM=*istpm* ISTT=*istpt* ERR=*errtol*

%

Where

*ntf*:

1 = Forward Euler method

2 = Predictor/Corrector method

*istpm*:

= initial mechanical load time step

*istpt*:

= initial thermal load time step

☞ **Note: only *istpm* is required for a mechanical load (*nse*=2) , only *istpt* is required for a thermal load (*nse*=1) and both *istpm* and *istpt* are required for a thermomechanical load (*nse*=3)**

*st<sub>i</sub>*

= initial time step for that load increment

*errtol*:

= error tolerance for predictor/corrector

☞ **Note: *errtol* is only required when using predictor/corrector (*ntf* = 2)  
Suggested *errtol* = 0.1**

**Example 1:** for a mechanical load, select predictor/corrector, with initial time step = 0.001 and error tolerance = 0.01

**\*SOLVER**

NTF=2

ISTM=0.001 ERR=0.01%



**Example 2:** select forward euler, time step = 0.001

**\*SOLVER**

NTF=1

NPTS=3 TIM=0.,1.,2. STP=0.01,0.02 %

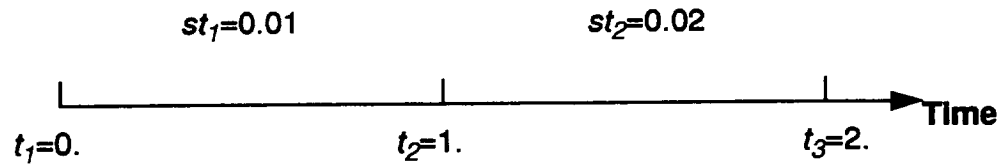

#### **4.2.10 Thermal Conductivity Calculation: (Optional)**

Purpose: Calculate thermal conductivity of the composite

**\*COND**

**Note:** If the **\*COND** keyword is not used, the thermal conductivity calculations are ignored.

#### **4.2.11 Constituent Material Model Identification:**

Purpose: To select the model for the fiber and matrix constituents

**\*FIBER**

NFIBS=*nfibs*

The following line is to be repeated for each fiber (*nfibs*):

NF=*nf<sub>f</sub>* MS=*ms<sub>f</sub>* MF=*ncmd<sub>f</sub>* NDPT=*dpt* MAT=*mat<sub>f</sub>*  
 IDB=*idb<sub>f</sub>* *f=1,2,...nfibs*

**\*MATRIX**

NMATX=*nmatx*

The following line is to be repeated for each matrix (*nmatx*):

NM=*nm<sub>m</sub>* MS=*ms<sub>m</sub>* MA=*ncmd<sub>m</sub>* NDPT=*dpt* MAT=*mat<sub>m</sub>*  
 IDB=*idb<sub>m</sub>* *m=1,2,...nmatx*

**\*MONOL (available for laminate option only)**

NMON=*nmon*

The following line is to be repeated for each isotropic material (*nmon*):

NMO=*nmo<sub>iso</sub>* MS=*ms<sub>iso</sub>* MMO=*ncmd<sub>iso</sub>* NDPT=*dpt* MAT=*mat<sub>iso</sub>*  
 IDB=*idb<sub>iso</sub>* *iso=1,2,...nmon*

%

Where

*nfibs*:

number of different fibers

*nmatx*:

number of different matrices

*nmon*:

number of different isotropic layers

*nf<sub>f</sub>*:

fiber material designation number running from 1 to *nfibs*, sequentially.

*nm<sub>m</sub>*:

matrix material designation number running from 1 to *nmatx*, sequentially.

*nmo<sub>iso</sub>*:

isotropic material designation number running from 1 to *nmon*.

*ms<sub>f</sub>*:

fiber material system id (required only when using laminate option)

*ms<sub>m</sub>*:  
matrix material system id. (required only when using laminate option)

*ms<sub>iso</sub>*:  
isotropic material system id (required only when using laminate option)

*ncmd*:  
material model identifier for either fiber, matrix or isotropic layer:  
 1 = Bodner-Partom Model  
 2 = Robinson Creep Model  
 3 = Robinson Non-normalized Viscoplastic Model  
 4 = Generalized Viscoplastic Potential Structure (GVIPS) Model  
 6 = Elastic Material Model  
 99= User defined model (see note on page 44 for special format instructions)

*mat*:  
material identification letter for either fiber or matrix, selected from material database, see Table I or II depending upon.

*idb*:  
read material constants from the database (y) or read from input file (n)

*dpt*: **(This flag is only required for the Bodner-Partom model)**  
 flag indicating whether material constants should be temperature independent or temperature dependent  
 1 = Temperature Independent  
 2 = Temperature Dependent

**Table I: Isothermal Material Constants**

**MAC Fiber Database**

Model	Material	Units	<i>mat</i>
Linear Elastic <i>ncmd</i> = 6	Boron	MPa	A
	SCS-6	MPa	B
	Tungsten	ksi	C
	SCS-6	ksi	D

## MAC Matrix Database

Model	Material	Units	mat
Bodner-Partom <i>ncmd</i> = 1	Aluminum	MPa, sec	A
Robinson Creep <i>ncmd</i> = 2	Kanthal	ksi, hr	A
Robinson Viscoplastic <i>ncmd</i> = 3	Kanthal FeCrAlY	ksi, hr ksi, hr	A B
GVIPS <i>ncmd</i> = 4	TIMETAL21S	ksi, sec	A

**Example 1:**

select 1 fiber, Boron, and 1 matrix material, Timetal21S, both read from database  
the Boron Timetal21S composite

**\*FIBER**

NFIB=1  
NF=1 MF=6 MAT=A IDB=y%

**\*MATRIX**

NMATX=1  
NM=1 MA=4 MAT=A IDB=y%

☞ **Note:** See Section 3.3 for a mathematical description of each material model.

**Example 2:** (select 2 matrix materials; material 1: Boron, read from database, material 2: Aluminum, user supplied properties)

**\*MATRIX**

NMATX=2  
NM=1 MA=6 MAT=A IDB=y  
NM=2 MA=1 MAT=A IDB=n EL=E,  $\nu$ , G,  $\alpha$  &  
VI=*a, b, c, d, ...* K= $\kappa_A, \kappa_T$  %

☞ **Note:** The  $\kappa_A, \kappa_T$  data is only required if the \*COND keyword has been used; where  $\kappa_A, \kappa_T$  are the axial and transverse thermal conductivities, respectively.

**Note: Required Format for User Supplied Isothermal Material Constants:**

Bodner-Partom:  $ncmd = 1$

Elastic:

$EL=E_L, E_T, \nu_A, \nu_T, G_A, \alpha_A, \alpha_T$

Inelastic:

$VI= D_0, Z_0, Z_1, m, n, q$

Robinson Creep:  $ncmd = 2$

Elastic:

$EL=E_L, E_T, \nu_A, \nu_T, G_A, \alpha_A, \alpha_T$

Inelastic:

$VI= \sigma_0, \dot{\epsilon}_0, n, \beta, m, R, H$

Robinson Viscoplastic:  $ncmd = 3$

Elastic:

$EL=E_L, E_T, \nu_A, \nu_T, G_A, \alpha_A, \alpha_T$

Inelastic:

$VI= n, m, \mu, \kappa_T, \beta, R, H, \hat{G}_0, \eta, \omega$

GVIPS:  $ncmd = 4$

Elastic:

$EL=E, \nu$

Inelastic:

$VI= \mu, \kappa, R_\alpha, R_\kappa, B_0, B_1, L_0, L_1, m, n, p, q, w, z_0$

Elastic Model:  $ncmd = 6$

$EL=E_L, E_T, \nu_A, \nu_T, G_A, \alpha_A, \alpha_T$

**Table II. Non-isothermal Material Constants**

The Following materials are available for a non-isothermal analysis:

**MAC Materials Database**

Model	Material	Units	mat
Bodner-Partom $ncmd = 1$	Graphite	MPa, sec, °C	A
	Aluminum	" "	B
GVIPS $ncmd = 4$	TIMETAL21S	ksi, sec	A

**Required Format for User Supplied Non-Isothermal Material Constants:**

**Note: each of the following data statements are separate lines.**

$NTP = n_{tpts}$   
 $TEM = T_1, T_2, \dots, T_{n_{tpts}}$   
 $EA = E_{AT_1}, E_{AT_2}, \dots, E_{AT_{n_{tpts}}}$   
 $ET = E_{TT_1}, E_{TT_2}, \dots, E_{TT_{n_{tpts}}}$   
 $NUA = \nu_{AT_1}, \nu_{AT_2}, \dots, \nu_{AT_{n_{tpts}}}$   
 $NUT = \nu_{TT_1}, \nu_{TT_2}, \dots, \nu_{TT_{n_{tpts}}}$   
 $GA = G_{AT_1}, G_{AT_2}, \dots, G_{AT_{n_{tpts}}}$   
 $ALPA = \alpha_{AT_1}, \alpha_{AT_2}, \dots, \alpha_{AT_{n_{tpts}}}$   
 $ALPT = \alpha_{TT_1}, \alpha_{TT_2}, \dots, \alpha_{TT_{n_{tpts}}}$   
 $DO = D_{0T_1}, D_{0T_2}, \dots, D_{0T_{n_{tpts}}}$   
 $Z0 = Z_{0T_1}, Z_{0T_2}, \dots, Z_{0T_{n_{tpts}}}$   
 $Z1 = Z_{1T_1}, Z_{1T_2}, \dots, Z_{1T_{n_{tpts}}}$   
 $BM = m_{T_1}, m_{T_2}, \dots, m_{T_{n_{tpts}}}$   
 $AN = n_{T_1}, n_{T_2}, \dots, n_{T_{n_{tpts}}}$   
 $Q = q_{T_1}, q_{T_2}, \dots, q_{T_{n_{tpts}}}$

☞ **Note:** For MF=99 (user defined material model) the following special format is required

**\*FIBER**

NFIBS=*nfibs*

The following line is to be repeated for each fiber (nfibs):

NF=*nf<sub>f</sub>* MS=*ms<sub>f</sub>* MF=99<sub>*f*</sub> NPE=*npe* EL= $\theta_1, \theta_2, \dots, \theta_{npe}$  &  
 NPV=*npv* VI= $v_1, v_2, \dots, v_{npv}$  K= $\kappa_A, \kappa_T$  %

**\*MATRIX**

NMATX=*nmatx*

The following line is to be repeated for each matrix (nmatx):

NM=*nm<sub>m</sub>* MS=*ms<sub>m</sub>* MA=99<sub>*m*</sub> NPE=*npe* EL= $\theta_1, \theta_2, \dots, \theta_{npe}$  &  
 NPV=*npv* VI= $v_1, v_2, \dots, v_{npv}$  K= $\kappa_A, \kappa_T$  %

where:

$npe$ :  
total number of elastic constants

$e_1, e_2, \dots$   
elastic constants

$npv$ :  
total number of inelastic constants

$v_1, v_2, \dots$   
inelastic constants

#### 4.2.12 RVE Data:

Purpose: Select RVE representing desired fiber packing arrangement/architecture

**\*MRVE**

IDP=*idp*

☞ **Note:** The following data is entered on the same line as *idp* (except where noted)

**Without Interface:**

• For IDP = 1, 2, or 3

VF=*vf*

• For IDP = 4

VF=*vf* XA=*xa*

• For IDP = 6

VF=*vf* R=*R*

• For IDP = 9

VF1=*vf1* RAD1=*rad1* VF2=*vf2* RAD2=*rad2* R=*R*

• For IDP = 11

VF=*vf1* RAD=*rad1* R=*R*

**With Interface:**

• For IDP = 1, 2, or 3

VF=*vf* RAD=*rad1* CPER=*cper*

• For IDP = 4

☞ **Currently NOT Available**

• For IDP = 6

☞ **Currently NOT Available**

• For IDP = 9

VF1=*vf1* RAD1=*rad1* CPER1=*cper1* VF2=*vf2* &  
RAD2=*rad2* CPER2=*cper2* R=*R*

• IDP = 11

VF=*vf1* RAD=*rad1* R=*R* CPER=*cper*

%

where:

*vf, vf1, vf2* = the fiber volume ratios

*rad, rad1, rad2* = fiber radii

*cper, cper1, cper2* = ratios of interface thickness to fiber radius

*xa* = length of the cross, see Fig. 6.



$R = X/Y$  which defines the ratio of distances between fibers within a “ply” and those between a “ply” (see figure 7)

*idp*:- ID of RVE as given below

**Note: For Double Periodic RVE:**

<u>idp</u>	<u>Description</u>
• 1 =	Square Fiber, Square Pack (original 4-cell model) $V_f \leq 1/(1 + \Delta)^2$ RVE shown in Fig. 5
• 2 =	Square Fiber, Triangular (hexagonal) Pack $V_f \leq 0.86602/(1 + \Delta)^2$ RVE shown in Fig. 5
• 3 =	Square Fiber, Square Diagonal Pack $V_f \leq 0.5/(1 + \Delta)^2$ RVE shown in Fig. 5
• 4 =	Cross Shaped Fiber, Square Pack $V_f \leq 1 - 4(xa)^2$ RVE shown in Fig. 5
• 6 =	Circular Fiber Approximation Rectangular or Square Pack $V_f \leq \frac{0.8125}{R(1 + \Delta)^2} \quad \text{if} \quad R > 1.0$ $V_f \leq \frac{R(0.8125)}{(1 + \Delta)^2} \quad \text{if} \quad R < 1.0$ RVE shown in Fig. 5

- 9 = Two Different Size Square Fibers, Rectangular or Square Pack

$$V_{f_2} \leq \frac{1}{R \left[ (1 + \Delta_2) + (1 + \Delta_1) \frac{R_{f_1}}{R_{f_2}} \right]^2}$$

$$V_{f_1} \leq \frac{2\sqrt{RV_{f_2}}}{\left[ \left( \frac{R_{f_2}}{R_{f_1}} \right)^2 (1 + \Delta_2) + \left( \frac{R_{f_2}}{R_{f_1}} \right) (1 + \Delta_1) \right]}$$

RVE shown in Fig. 5

- 11 = Square Fiber, Rectangular Pack

$$V_f \leq \frac{1}{R(1 + \Delta)^2} \quad \text{if} \quad R > 1.0$$

$$V_f \leq \frac{R}{(1 + \Delta)^2} \quad \text{if} \quad R < 1.0$$

RVE shown in Fig. 5

- 99 = User Defined RVE  
Example of RVE representing random packing shown in Fig. 8. Required input shown in Appendix F.

☞ **Note: For Triple Periodic RVE:**

- 99 = User Defined RVE

☞ **Note:**  $R, R_{f_1}, R_{f_2}, V_f, \Delta = cper, \Delta_1 = cper1$  and  $\Delta_2 = cper2$  are defined later in this subsection

☞ **Note:** The images of the RVE's shown in Figs.5 and 8 were generated using the PATRAN option (sec 4.2.8) available in MAC.

**Example: Triangular packing with interface thickness 1% of fiber radius.**

**\*MRVE**

IDP=2 VF=35 RAD=0.07 CPER=0.01 %

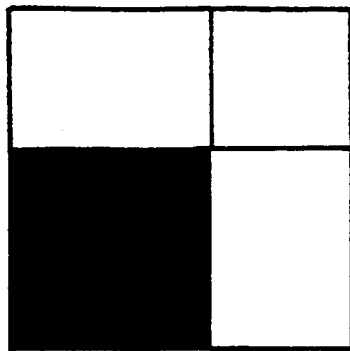

IDP = 1

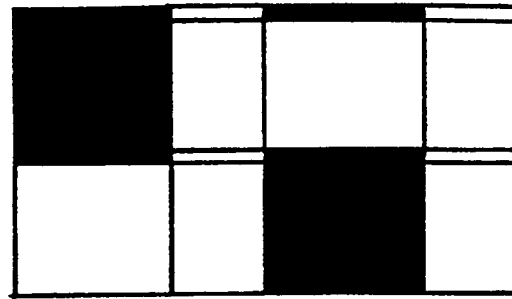

IDP = 2

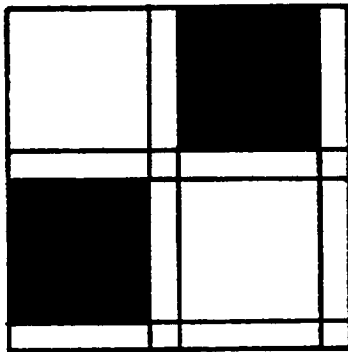

IDP = 3

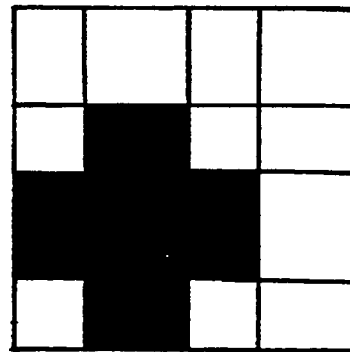

IDP = 4

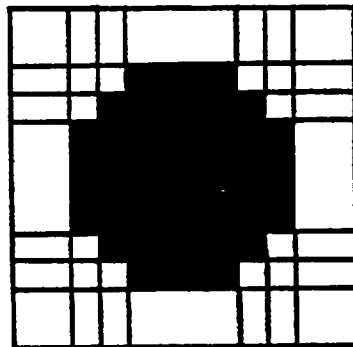

IDP = 6

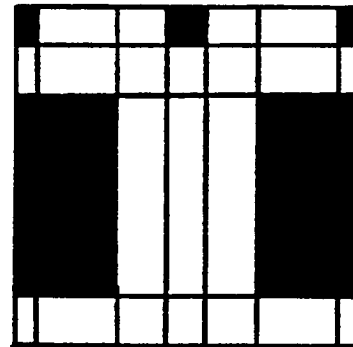

IDP = 9

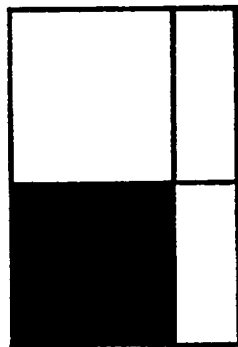

IDP = 11

Matrix



Fiber



Figure 5: RVE's Available in MAC

Fig. 6 Cross Shaped Fiber Distance xa

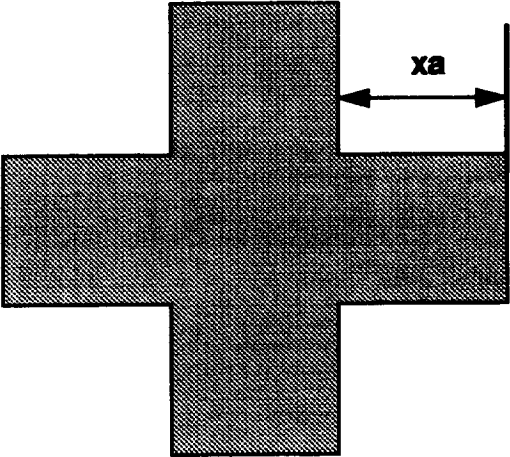
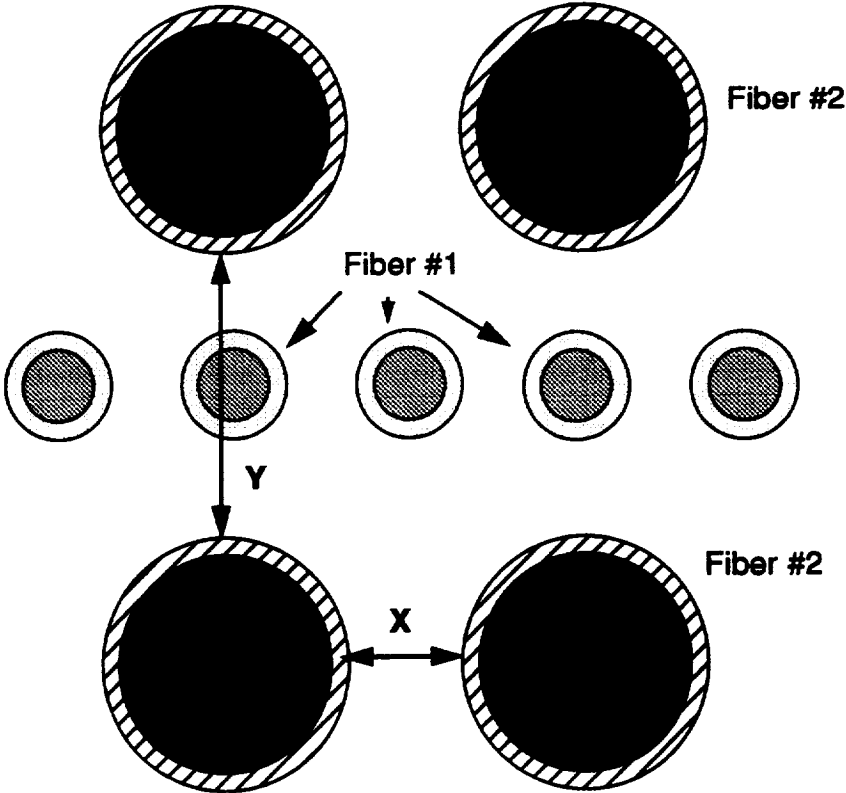

Fig.7 \_\_Hybrid Composite RVE; IDP = 9. Fiber Spacing Ratio,  $R=X/Y$



**Note: Format for the user defined RVE's, IDP = 99, see Fig. 8 for example.**

1) For 2-D RVE: (Each line of data must be on a separate line)

NB=nb NG=ng

H=h<sub>1</sub>, h<sub>2</sub>, .... h<sub>ng</sub>

L=l<sub>1</sub>, l<sub>2</sub>, .... l<sub>nb</sub>

CM=ss<sub>nb,1</sub>,ss<sub>nb,2</sub>...ss<sub>nb,ng</sub>

repeat data for the (nb x ng) 2-D RVE

CM=ss<sub>1,1</sub>,ss<sub>1,2</sub>...ss<sub>1,ng</sub>

2) For 3-D RVE: (Each line of data must be on a separate line)

NA=na NB=nb NG=ng

D=d<sub>1</sub>,d<sub>2</sub>...d<sub>na</sub>

H=h<sub>1</sub>, h<sub>2</sub>, .... h<sub>ng</sub>

L=l<sub>1</sub>, l<sub>2</sub>, .... l<sub>nb</sub>

CM=ss<sub>na,1,1</sub>,ss<sub>na,2,1</sub>...ss<sub>na,nb,,1</sub>

CM=ss<sub>na-1,1,1</sub>,ss<sub>na-1,2,1</sub>...ss<sub>na-1,nb,,1</sub>

repeat data for the (na x nb x ng) 3-D RVE

CM=ss<sub>1,1,ng</sub>,ss<sub>1,2,ng</sub>...ss<sub>1,nb,ng</sub>

Where

ss<sub>i,j</sub> and ss<sub>i,j,k</sub> are the identifying material labels which are given in the following format:

first character: F - for a fiber or M - for matrix

second character: 1, 2, 3, ... for fiber/matrix number 1, 2, 3 ...

na - number of subcells in the alpha direction

nb - number of subcells in the beta direction

ng - number of subcells in the gama direction

h - the height of each subcell

l - the length of each subcell

d - the depth of each subcell

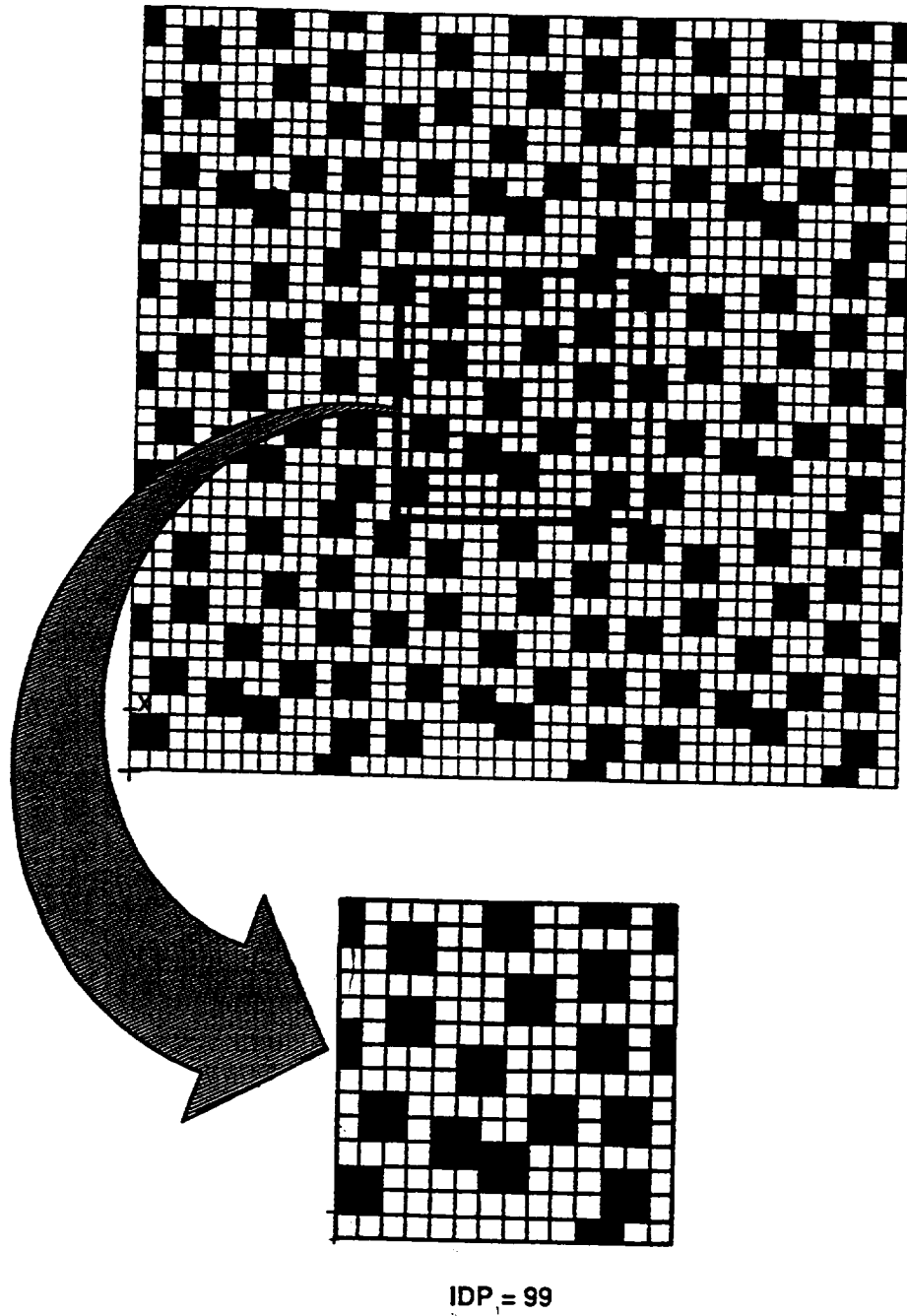
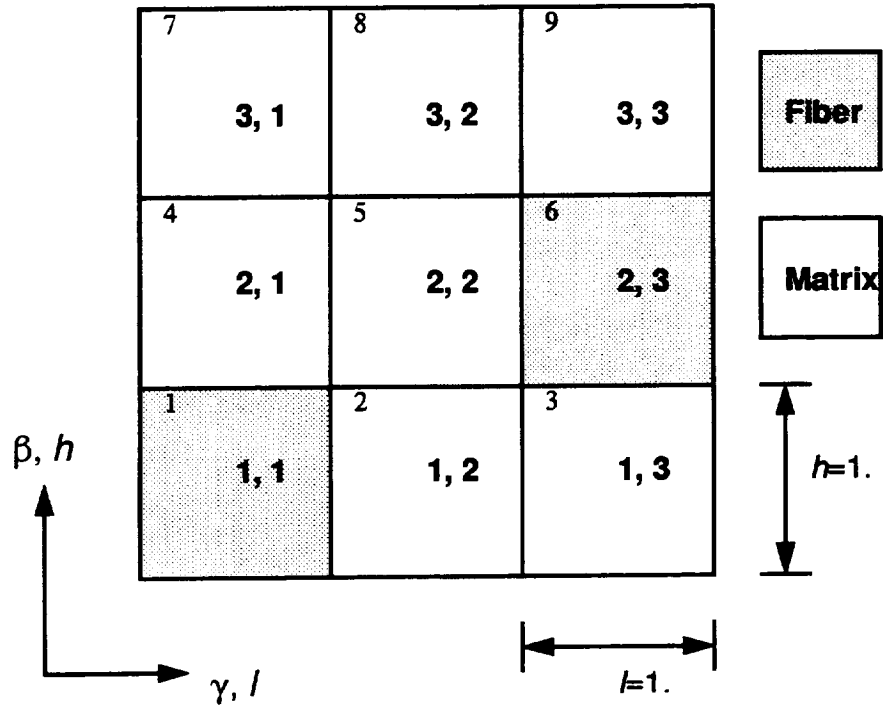

Figure 8: User defined RVE



**Example:** (2-D user defined RVE (as shown above))

**\*MRVE**

IDP=99

NB=3 NG=3

H=1.,1.,1.

L=1.,1.,1.

CM=M1,M1,M1

CM=M1,M1,F1

CM=F1,M1,M1 %

**Note:** the fiber id. is F1 and the matrix id. is M1

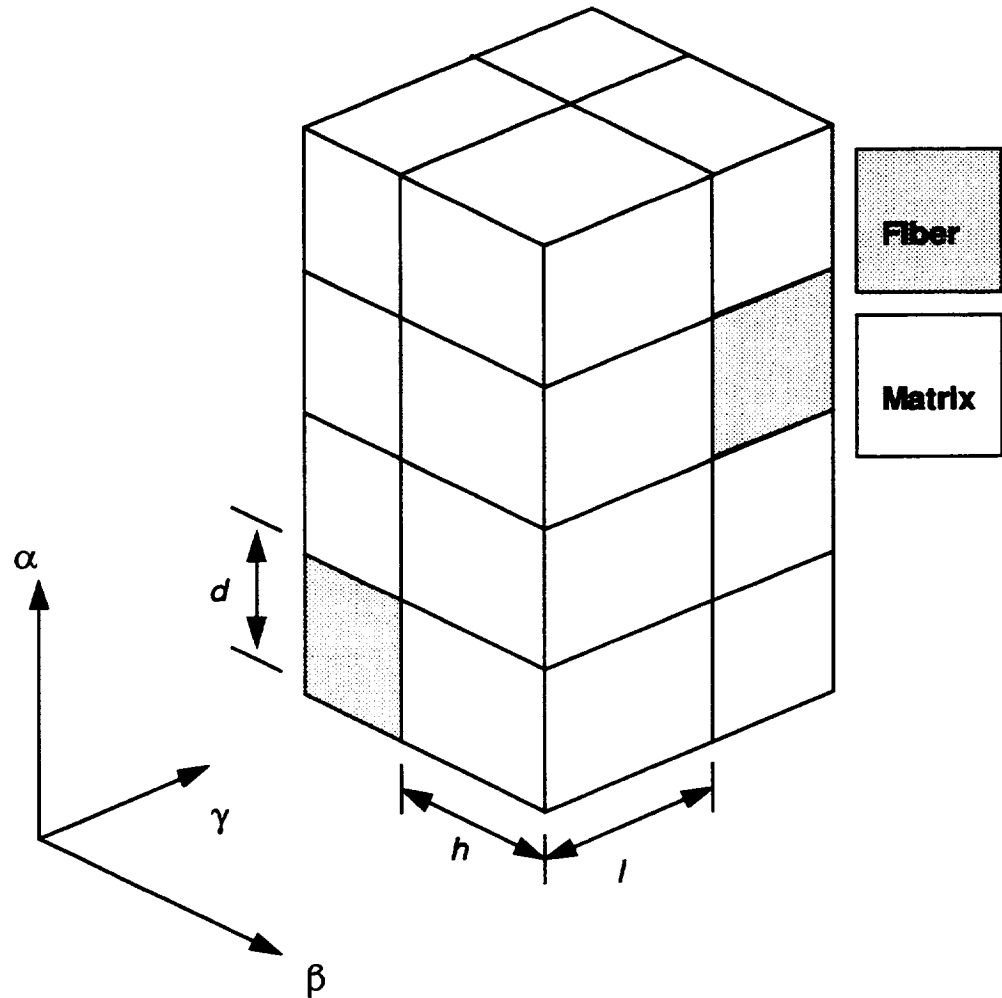

**Example:** A 3-D User defined RVE (as shown above), representing a [0/90] continuous reinforced laminate composite.

☞ **Note:** the fiber is material number 1 and the matrix is material number 2.



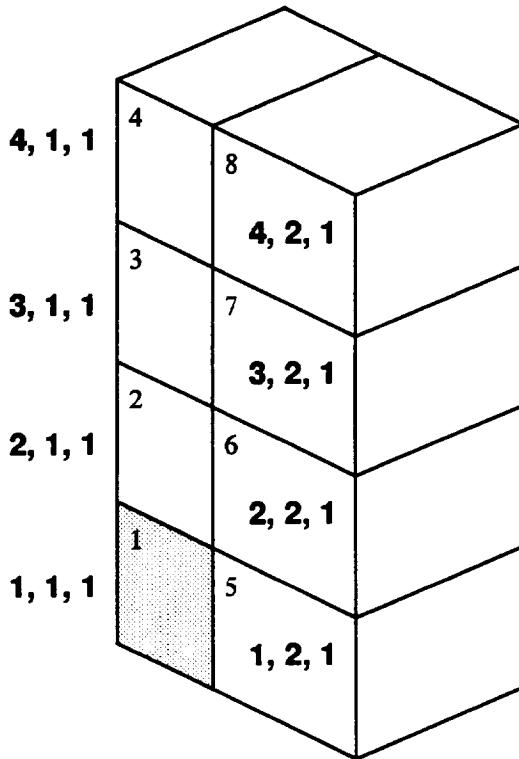

cross-section 1

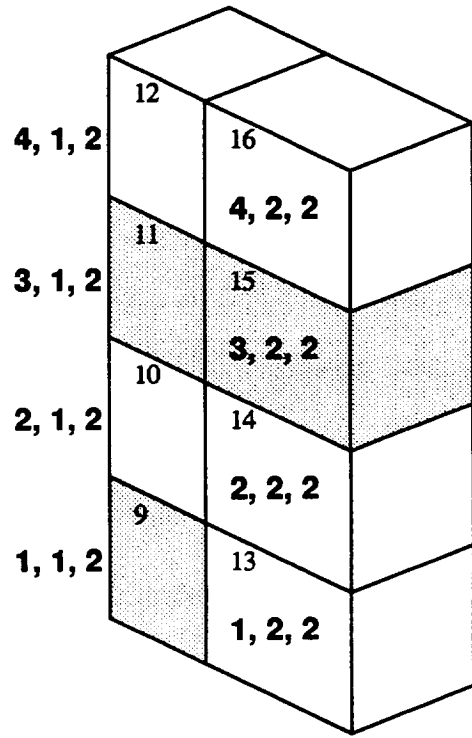

cross-section 2

**\*MRVE**

IDP=99 ASC=1.

NA=4 NB=2 NG=2

D=1.,1.,1.,1.

H=1.,1.

L=1.,1.

CM=M1,M1

rows 1-4 are for cross-section 1

CM=M1,M1

CM=M1,M1

CM=F1,M1

CM=M1,M1

rows 5-8 are for cross-section 2

CM=F1,F1

CM=M1,M1

CM=F1,M1 %

#### 4.2.13 Interface Data: (Optional, for IDP=1,2,3,9 or 11)

Purpose: Specify interface layer properties

**\*INTERFACE**

NINT=*nint*

The following line is to be repeated for each interface(*nint*):

NI=*nm*<sub>1</sub> MI=*ncmd*<sub>1</sub> MAT=*mat*<sub>1</sub> IDB=*idb*<sub>1</sub>

%

☞ **Note:** If *idb*=n see section 4.2.11 for format of additional input required.

Where

*nint*:

number of different interfaces

*nm*:

interface number

*ncmd*:

material model identifier for the interface

*mat*:

material id letter

*idb*:

= y use database properties

= n user specified properties

☞ **Note:** Please refer to section 4.2.11 for *ncmd* and *mat* values

**Example: (Assuming one interface with user supplied material constants)**

\*INTERFACE

NINT=1

NI=1 MI=4 MAT=C IDB=n &

EL=11700.,11700.,0.365,0.365,4287.5,1.,1. &

VI=0.8E-8,0.1,0.1E-5,0.,0.85E-3,0.05,1.,1.,1.,3.3,1.8,1.35,1.,0.01 %

#### **4.2.14 Debond Data: (Optional)**

Purpose: Specify the subcell faces where debond can take place (see section 3.6)

#### **2-D GMC Model Format**

**\*DEBOND**

$NII=nii$

$NBI=nbi$   $NGI=ngi$   $FACE=nfc$   $RN=rn$   $BDN=bdstrn$   $RS=rs$  &

$BDS=bdstrs$   $TI=tmd$

%

#### **3-D GMC Model Format**

**\*DEBOND**

$NII=nii$

$NAI=nai$   $NBI=nbi$   $NGI=ngi$   $FACE=nfc$   $RN=rn$   $BDN=bdstrn$   $RS=rs$  &

$BDS=bdstrs$   $TI=tmd$

%

Where

*nii*:

number of subcell interfaces with debond

*nai, nbi* and *ngi*:

subcell indices ( $\alpha, \beta, \gamma$ )

*nfc*:

used specify which "face" of the subcell is to be debonded

For 2-D GMC

= 1 Top Face

= 2 Right Face

= 3 Both Faces

For 3-D GMC

= 1 Top Face

= 2 Right Face

= 3 Back Face

= 4 Top & Right Face

= 5 Top & Back Face

= 6 Right & Back Face

= 7 ALL Faces

*rn*:

$R_n$  value

*bdstrn*:

debond stress, normal component (see Fig. 9)

*rs*:

$R_s$  value

*bdstrs*:

debond stress, shear component (see Fig. 9)

*tmd*:

time at which debond criteria becomes active  
(defaults to *tmd*=0. if not specified)

**Example 1:**

**debond subcell 1,1 top face normal component**

NII=1

NBI=1 NGI=1 FACE=1 RN=1. BDN=100.

**Example 2:**

**debond subcell 1,1 right face shear component**

NII=1

NBI=1 NGI=1 FACE=2 RS=1. BDN=100.

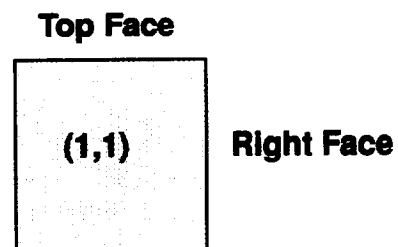
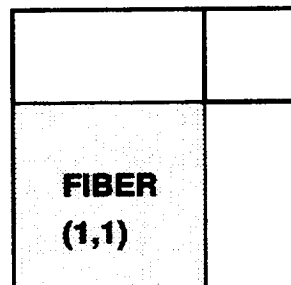

Figure 9: Subcell Faces For 2-D GMC

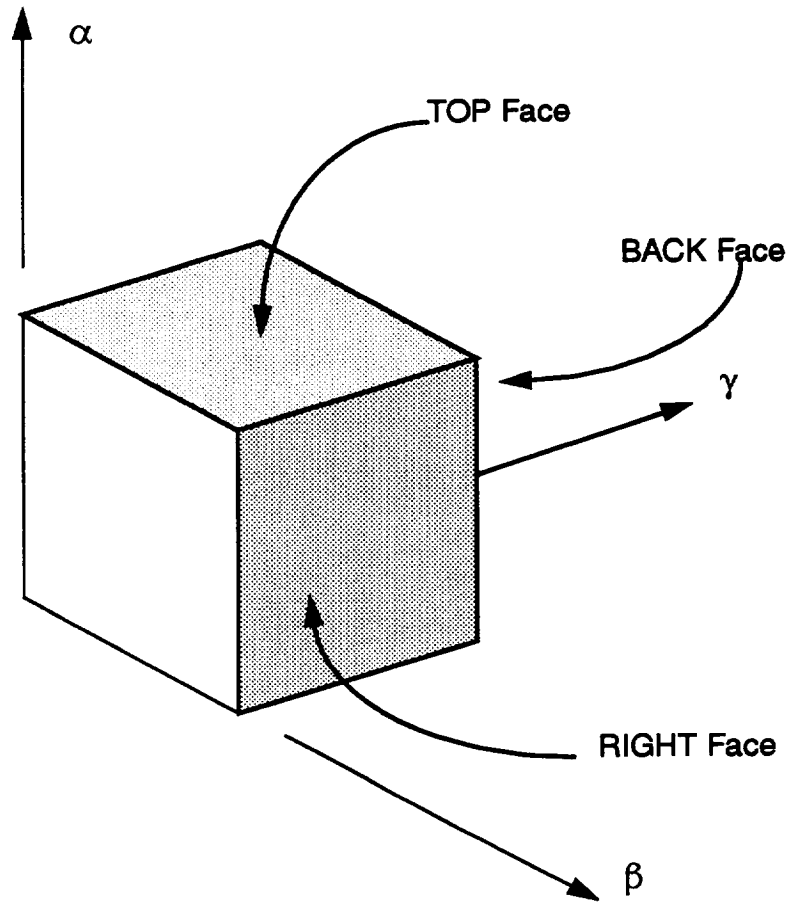

Figure 10: Subcell Faces For 3-D GMC

#### **4.2.15 Plot Point Information:**

Purpose: Specify the frequency at which data will be written to output files for both X-Y data

```
*CURVE  
NP=npmax
```

```
%
```

Where

*npmax*:  
plot point increment

**Example::** (print out every fifth data point)

```
*CURVE  
NP=5 %
```

**4.2.16 Curve Data:**

☞ **Note:** Currently a maximum of 5 curves may be specified per problem

**Specifying Curve Data For Macro (composite) Quantities:**

**\*MACRO**

NT=*nucuv*

Repeat the following line *nucuv* times:

NC=*nocu* X=*maidx* Y=*maidy* NAM=*tname*

%

Where

*nocu*: - curve number

*maidx* and *maidy* variable options are:

1 - $e_{11}$	7 - $\sigma_{11}$	13 - $\epsilon_{11}^i$	19 - $\epsilon_{11}^{th}$	22 - Total Time
2 - $e_{22}$	8 - $\sigma_{22}$	14 - $\epsilon_{22}^i$	20 - $\epsilon_{22}^{th}$	23 - Creep Time
3 - $e_{33}$	9 - $\sigma_{33}$	15 - $\epsilon_{33}^i$	21 - $\epsilon_{33}^{th}$	24 - Temperature
4 - $\gamma_{23}$	10 - $\tau_{23}$	16 - $\gamma_{23}^i$		
5 - $\gamma_{13}$	11 - $\tau_{13}$	17 - $\gamma_{13}^i$		
6 - $\gamma_{12}$	12 - $\tau_{12}$	18 - $\gamma_{12}^i$		

*tname*: name of plot file

☞ **Note:** The file(s) generated will be of the form *tname*\_mac.data. If the user desires to use the same *tname* for files 2-5, a double quote, “, is entered for *tname*. Those files then will have the form:

*tname2*\_mac.data

*tname3*\_mac.data

etc.

(see the example for more details)

**EXAMPLE:**

**\*MACRO**

NT=3

NC=1 X=1 Y=7 NAM=stress file created: **stress\_mac.data**

NC=2 X=22 Y=13 NAM="" file created: **stress2\_mac.data**

NC=3 X=23 Y=13 NAM=plot % file created: **plot\_mac.data**

**Specifying Curve Data for Micro (subcell) Quantities:**

**\*MICRO**

NT=*nucuv*

Repeat the following line *nucuv* times:

NC=*nocu* CELL=*nssel* X=*maidx* Y=*maidy* NAM=*tname2*

%

Where

*nocu*: - curve number

*nssel*: - cell number

*tname2*: - name of plot file

*miidx* and *miidy* variable options are:

1 - $e_{11}$	7 - $\sigma_{11}$	13 - $\epsilon_{11}^i$	19 - $\Phi_{11}$	25 - $\Psi_{11}$	31 - Total Time
2 - $e_{22}$	8 - $\sigma_{22}$	14 - $\epsilon_{22}^i$	20 - $\Phi_{22}$	26 - $\Psi_{22}$	32 - Creep Time
3 - $e_{33}$	9 - $\sigma_{33}$	15 - $\epsilon_{33}^i$	21 - $\Phi_{33}$	27 - $\Psi_{33}$	33 - Temperature
4 - $\gamma_{23}$	10 - $\tau_{23}$	16 - $\gamma_{23}^i$	22 - $\Phi_{23}$	28 - $\Psi_{23}$	
5 - $\gamma_{13}$	11 - $\tau_{13}$	17 - $\gamma_{13}^i$	23 - $\Phi_{13}$	29 - $\Psi_{13}$	
6 - $\gamma_{12}$	12 - $\tau_{12}$	18 - $\gamma_{12}^i$	24 - $\Phi_{12}$	30 - $\Psi_{12}$	

☞ **Note:** The quantities  $\Phi$  and  $\Psi$  are the possible internal state variables (constitutive model dependent).



☞ **Note:** The file(s) generated will be of the form *tname2\_mic.data*. If the user desires to use the same *tname2* for files 2-5, a double quote, " , is entered for *tname2*. Those files then will have the form:

*tname22\_mic.data*  
*tname23\_mic.data*  
etc.

(see the example for more details)

☞ **Note:** Subcell numbering is assigned according to the following algorithm.

### 2-D case

```
Do * IB=1,NB
Do * IG=1,NG
subcell number = NG*(IB-1)+IG
* continue
```

### 3-D case

```
Do * IA=1,NA
Do * IB=1,NB
Do * IG=1,NG
subcell number = IA+(IB-1)*NA+(IG-1)*NA*NB
* continue
```

☞ **Note:** Refer to numbers in upper left corners of subcells in Figures on page 52 and 54 for examples of subcell numbering scheme.

### EXAMPLE:

#### \*MICRO

NC=1 CELL=1 X=1 Y=7 NAM=cell %

file created: cell\_mic.data

## **5.0 Conclusion/Future Modifications**

A computationally efficient, user-friendly, comprehensive, micromechanics analysis tool, **MAC**, has been presented that admits physically based viscoplastic deformation and life models, can analyze multiphased materials of interest in advanced propulsion systems, and can assist both the material scientist and structural analyst in developing, designing and analyzing strategic materials. However, the development of this tool is far from complete. A number of future enhancements that are planned and currently underway include:

- Provide an implicit integration algorithm to improve computational efficiency.
- Provide the ability to input a multiaxial state of loading, be it stress or strain.
- Provide the ability to input multiple runs within the same input data file.
- The incorporation of damage evolution laws and failure criteria so as to provide life estimates.

### **5.1 Acknowledgment**

The authors would like to thank Mr. Robert Goldberg for his diligent efforts and assistance in checking the accuracy and consistency of this manual by running numerous test cases. Future users will be, as the authors are, grateful.

## 6.0 Appendix A

### Sample Input File For A Mechanical Load Problem

The following example is used to explain the control blocks in more detail.

#### Problem Summary:

Load Type:	Mechanical
Load Component:	22-direction (transverse to fiber)
Load History:	Cyclic
Load Control:	Strain
Load History Data:	$\dot{\epsilon} = 8.333 \times 10^{-4}$ , $\epsilon_{max} = 0.015$ , $\epsilon_{min} = 0$ . $\Delta t_{initial} = 0.0000024$
Micromechanics model:	Double Periodicity
Fiber Packing Arrangement:	Hexagonal Pack at 35% fiber volume ratio
Integration Algorithm:	Predictor/Corrector
Constituent Material Model:	GVIPS
Constituents:	Fiber: SCS-6 Matrix: TIMETAL21S Interface: fictitious weak interface for TIMETAL21S

**Note:** This example will take an extremely long time to run due to the elastic-perfectly viscoplastic definition of the fictitious weak interface, as the overall time step is limited to that of the allowable interface time step. This slow computational response is NOT indicative of GMC.

FOR MECHANICAL LOAD RUN

\*PRINT

NPL=0 %

\*LOAD

LCON=2 LOP=2 LSS=1 %

\*MECH

NPTW=2 TI=0.,18. LO=0.,0.015 %

\*TREF

TREF=650. %

\*MODEL

MOD=1 %

\*SOLVER

NTF=2 ISTM=0.0000024 ERR=0.1E-2 %

\*FIBER

NFIBS=1

NF=1 MF=4 MAT=B IDB=y %

\*MATRIX

NMATX=1

NM=1 NM=4 MAT=A IDB=y %

\*MRVE

IDP=2 VF=0.35 RAD=0.07 CPER=0.1 %

\*INTERFACE

NINT=1

NI=1 MI=4 MAT=C IDB=n &

EL=11700.,11700.,0.365,0.365,4287.5,1.,1. &

VI=0.8E-8,0.1,0.1E-5,0.,0.85E-3,0.05,1.,1.,1.,3.3,1.8,1.35,1.,0.01 %

\*CURVE

NP=2 %

\*MACRO

NT=1

NC=1 X=2 Y=8 NAM=apdx %

\*END

The following figure was obtained from the x-y plot data file produced by the present example.

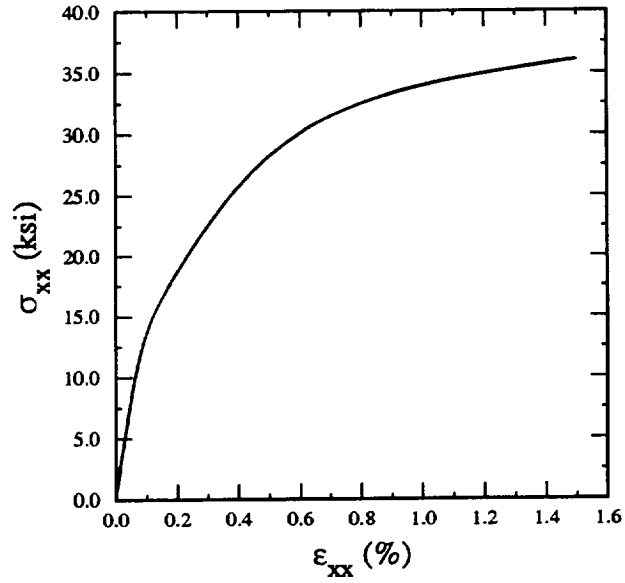

**Note:** It is recommended that a new user construct a mac input file using the data given in this appendix and then check to see if the same result plot is obtained.

## 7.0 Appendix B

### Sample Input File For A Thermal Load Problem

The following example is used to explain the control blocks in more detail.

#### Problem Summary:

Load Type:	Thermal
Load History Data:	$\dot{T} = 0.01,$ $T_{max} = 371.1,$ $T_{min} = 21.1$ $\Delta t_{initial} = 17.505$
Micromechanics model:	Double Periodicity
Fiber Packing Arrangement:	Square Pack at 35% fiber volume ratio
Integration Algorithm:	Predictor/Corrector
Constituent Material Model:	Bodner-Partom
Constituents:	Fiber: Graphite Matrix: Aluminum

☞ **Note:** This problem is taken from reference 1., pg.238

FOR THERMAL LOAD RUN

```
*PRINT
  NPL=0 %
*LOAD
  LCON=1 %
*THERM
  NPTT=3 TI=0.,35010.,70020. &
  TE=371.1,21.1,371.1 %
*TREF
  TREF=371.1 %
*MODEL
  MOD=1 %
*SOLVER
  NTF=2 ISTT=17.505 ERR=10.E-2 %
*FIBER
  NFIBS=1
  NF=1 MF=1 NDPT=2 MAT=A IDB=y %
*MATRIX
  NMATX=1
  NM=1 MM=1 NDPT=2 MAT=B IDB=y %
*MRVE
  IDP=1 VF=0.30 %
*CURVE
  NP=5 %
*MACRO
  NT=1
  NC=1 X=24 Y=1 NAM=thermal %
*END
```

The following figure was obtained from the x-y plot data file produced by the present example.

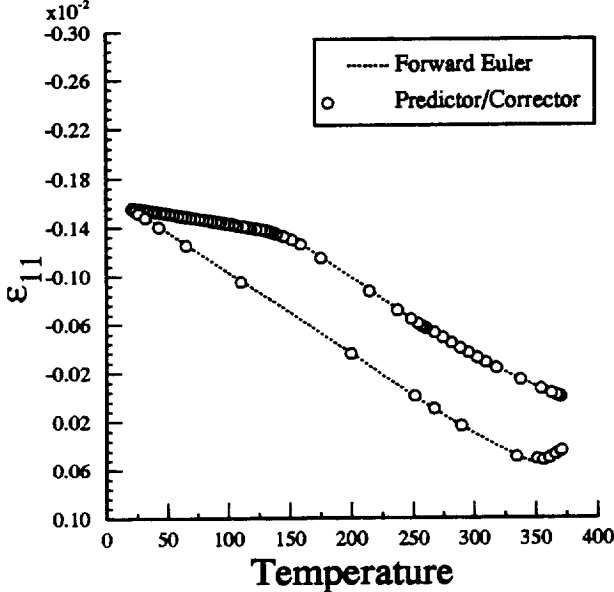

**Note:** It is recommended that a new user construct a mac input file using the data given in this appendix and then check to see if the same result plot is obtained.



## 8.0 Appendix C

### Sample Input File For A Laminate Problem

The following example is used to explain the control blocks in more detail.

#### Problem Summary:

Load Type:	Strain Control
Load History Data:	$\dot{\epsilon} = 0.01$ , $\epsilon_{max} = 0.01$ , $\Delta t_{constant} = 0.00025$
Micromechanics model:	Laminate with Double Periodicity
Fiber Packing Arrangement:	Square Pack at 46% fiber volume ratio
Integration Algorithm:	Forward Euler
Constituent Material Model:	Bodner-Partom
Constituents:	Fiber: Boron Matrix: Aluminum

test of laminate strain control

```
*PRINT
  NPL=0 %
*LOAD
  LCON=2 LOP=1 LSS=1 %
*MECH
  NPTW=2 TI=0.,1. LO=0.,0.01 %
*MODEL
  MOD=3 MATSYS=1 NLY=1 THK=1. ANG=0. %
*SOLVER
  NTF=1 NPTS=2 TIM=0.,1. STP=0.00025 %
*FIBER
  NFIBS=1
  NF=1 MS=1 MF=6 MAT=A IDB=y %
*MATRIX
  NMATX=1
  NM=1 MS=1 MM=1 MAT=A IDB=y %
*MRVE
  IDP=1 VF=0.46 %
*CURVE
  NP=10 %
*MACRO
  NT=1
  NC=1 X=1 Y=7 NAM=apdxc %
*END
```

The following figures were obtained from the x-y plot data file produced by the present example.

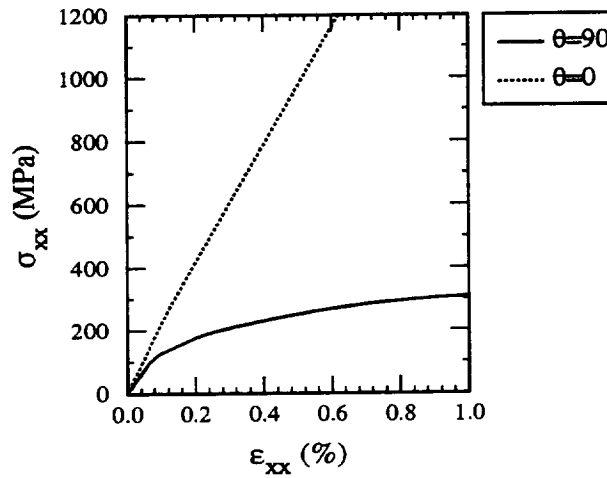

From reference 1 Fig. 8-5, pg. 235

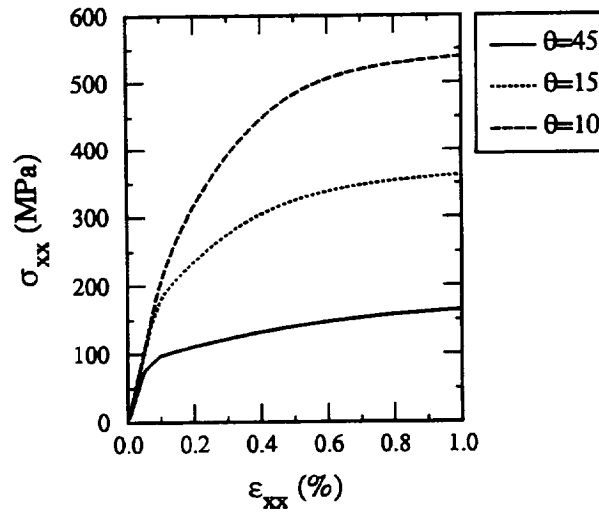

From reference 1 Fig. 8-7, pg. 237

## 9.0 Appendix D

### Sample Input File For A Laminate Problem

The following example is used to explain the control blocks in more detail.

#### Problem Summary:

Load Type:	Stress Control
Load History Data:	$\dot{\sigma} = 0.01$ ksi/sec, $\sigma_{max} = 45.$ , $\Delta t_{constant} = 1.125$
Micromechanics model:	$[\pm 45]_s$ Laminate with Double Periodicity
Fiber Packing Arrangement:	Square Pack at 45% fiber volume ratio
Integration Algorithm:	Forward Euler
Constituent Material Model:	Bodner-Partom
Constituents:	Fiber: Boron Matrix: Aluminum

☛ **Note:** This problem is taken from the reference:  
Analysis of Metal-Matrix Composite Structures-II.  
Laminate Analysis, Arenburg, R. T. and Reddy, J. N.,  
Computers and Structures, Vol. 40, N.6, pp. 1369-1385, 1991.

test of [+45]2s laminate strain control

\*PRINT

NPL=0 %

\*LOAD

LCON=2 LOP=1 LSS=2 %

\*MECH

NPTW=2 TI=0.,4500. LO=0.,45. %

\*TREF

TREF=0. %

\*MODEL

MOD=3 MATSYS=1 NLY=4 THK=0.25,0.25,0.25,0.25 ANG=45.,-45.,-45.,45. %

\*SOLVER

NTF=1 NPTS=2 TIM=0.,4500. STP=1.125 %

\*FIBER

NFIBS=1

NF=1 MS=1 MF=6 MAT=A IDB=n &

EL=58.E3,58.E3,0.20,0.20,24.17E3,6.3E-6,8.28E-6 %

\*MATRIX

NMATX=1

NM=1 MS=1 MM=1 MAT=A IDB=n &

EL=9.53E3,9.53E3,0.33,0.33,3.58E3,21.06E-6,21.06E-6 &

VI=1.E4,49.,63.,300.,4.,1. %

\*MRVE

IDP=1 VF=0.45 %

\*CURVE

NP=10 %

\*MACRO

NT=1

NC=1 X=1 Y=7 NAM=apdxd %

\*END

The following figure was obtained from the x-y plot data file produced by the present example.

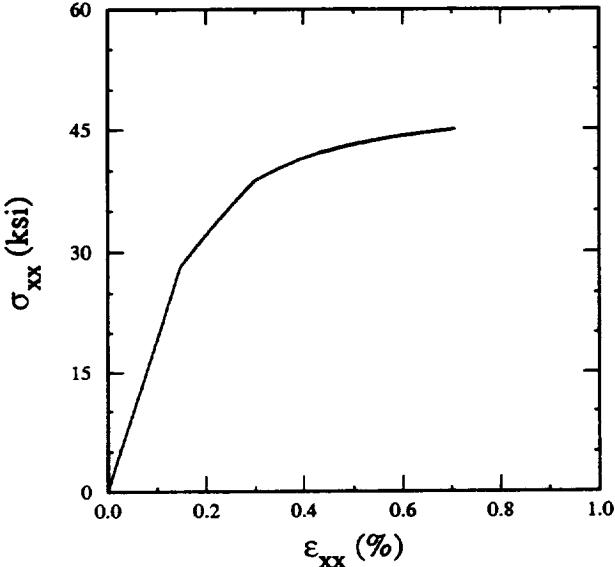

From Arenburg and Reddy, Fig. 16, pg. 1382.

## 10.0 Appendix E

### Sample Input File For Triple Periodic GMC

The following example is used to explain the control blocks in more detail.

#### Problem Summary:

Load Type:	Strain Control
Load History Data:	$\dot{\epsilon} = 0.01$ , $\epsilon_{max} = 0.01$ , $\Delta t_{constant} = 0.00025$
Micromechanics model:	Triple Periodic GMC
Fiber Packing Arrangement:	Square Pack at 46% fiber volume ratio
Integration Algorithm:	Forward Euler
Constituent Material Model:	Bodner-Partom
Constituents:	Fiber: Boron Matrix: Aluminum

This problem uses the 3-D GMC model to simulate a [0/90] laminate as shown below.

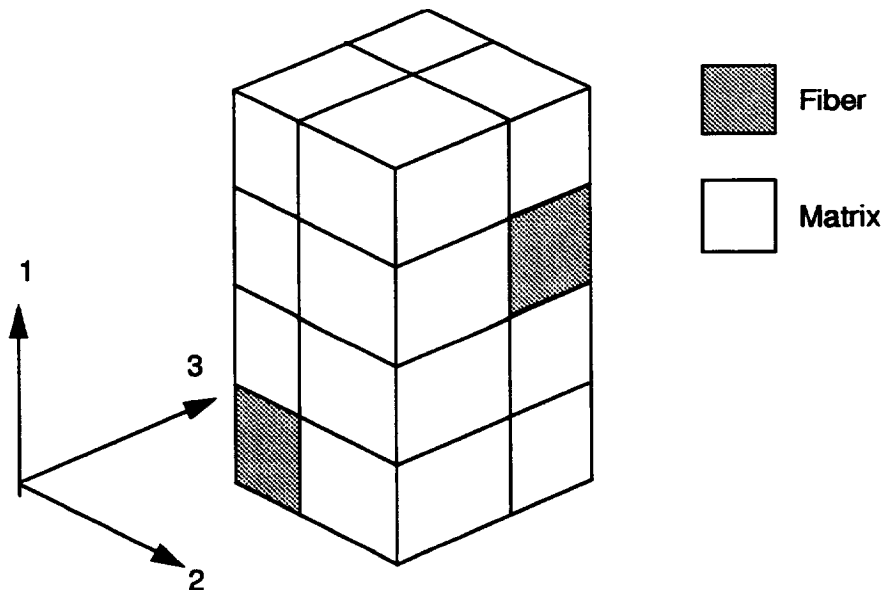

test of gmc3d model 0/90 laminate simulation

```
*PRINT
  NPL=0 %
*LOAD
  LCON=2 LOP=2 LSS=1 %
*MECH
  NPTW=2 TI=0.,1. LO=0.,0.01 %
*MODEL
  MOD=2 %
*SOLVER
  NTF=1 NPTS=2 TIM=0.,1. STP=0.00025 %
*FIBER
  NFIBS=1
  NF=1 MF=6 MAT=A IDB=y %
*MATRIX
  NMATX=1
  NM=1 MM=1 MAT=A IDB=y %
*MRVE
  IDP=99 ASP=1.
  NA=4 NB=2 NG=2
  D=0.67823,0.32177,0.67823,0.32177
  H=0.67823,0.32177
  L=0.32177,0.67823
  CM=2,2
  CM=2,2
  CM=2,2
  CM=1,2
  CM=2,2
  CM=1,1
  CM=2,2
  CM=1,2 %
*CURVE
  NP=10 %
*MACRO
  NT=1
  NC=1 X=2 Y=8 NAM=apdxe %
*END
```



The following figure was obtained from the x-y plot data file produced by the present example.

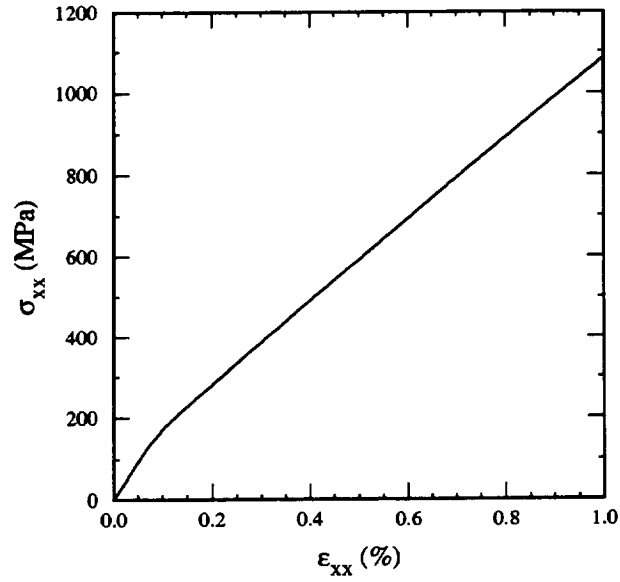

**Note:** It is recommended that a new user construct a mac input file using the data given in this appendix and then check to see if the same result plot is obtained.

## 11.0 Appendix F

### Sample Input File For A User Defined RVE

The following example is used to explain the control blocks in more detail.

#### Problem Summary:

Load Type:	Strain Control
Load History Data:	$\dot{\epsilon} = 0.01$ , $\epsilon_{max} = 0.001$ , $\Delta t_{constant} = 0.1$
Micromechanics model:	Double periodic
Fiber Packing Arrangement:	Random composite (see figure 8)
Integration Algorithm:	Forward Euler
Constituent Material Model:	Bodner-Partom
Constituents:	Fiber: Boron Matrix: Aluminum

```
random composite rve using 2-d gmc
*PRINT
  NPL=0 %
*LOAD
  LCON=2 LOP=1 LSS=2 %
*MECH
  NPTW=2 TI=0.,0.1 LO=0.,0.001 %
*MODEL
  MOD=1 %
*SOLVER
  NTF=1 NPTS=2 TIM=0.,0.1 STP=0.1 %
*FIBER
  NFIBS=1
  NF=1 MF=6 MAT=A IDB=y %
*MATRIX
  NMATX=1
  NM=1 MM=1 MAT=A IDB=y %
*MRVE
  IDP=99
  NB=14 NG=14
  H=1.,1.,1.,1.,1.,1.,1.,1.,1.,1.,1.,1.,1.,1.,1.
  L=1.,1.,1.,1.,1.,1.,1.,1.,1.,1.,1.,1.,1.,1.,1.
  CM=F1,M1,M1,M1,M1,M1,F1,F1,M1,M1,F1,F1,M1,F1
  CM=F1,M1,F1,F1,M1,M1,F1,F1,M1,M1,M1,M1,M1,F1
  CM=M1,M1,F1,F1,M1,M1,M1,M1,M1,M1,F1,F1,M1,M1
  CM=M1,M1,M1,M1,M1,M1,M1,F1,F1,M1,F1,F1,M1,M1
  CM=M1,M1,F1,F1,M1,M1,M1,F1,F1,M1,M1,M1,M1,M1
  CM=F1,M1,F1,F1,M1,M1,M1,M1,M1,F1,F1,M1,F1
  CM=F1,M1,M1,M1,M1,F1,F1,M1,M1,M1,F1,F1,M1,F1
  CM=M1,M1,M1,M1,M1,F1,F1,M1,M1,M1,M1,M1,M1,M1
  CM=M1,F1,F1,M1,M1,M1,M1,M1,F1,F1,M1,F1,F1,M1
  CM=M1,F1,F1,M1,F1,F1,M1,M1,F1,F1,M1,F1,F1,M1
  CM=M1,M1,M1,M1,F1,F1,F1,F1,M1,M1,M1,M1,M1,M1
  CM=F1,F1,M1,M1,M1,M1,F1,F1,M1,M1,M1,F1,F1,M1
  CM=F1,F1,M1,M1,M1,M1,M1,M1,M1,M1,F1,F1,M1
  CM=M1,M1,M1,M1,M1,M1,M1,M1,M1,M1,F1,F1,M1,M1 %
*CURVE
  NP=1 %
*MACRO
  NT=1
  NC=1 X=1 Y=7 NAM=apdx1 %
*END
```

## 12.0 Appendix G

### Sample Input File For A Biaxial Load

The following example is used to explain the control blocks in more detail.

#### Problem Summary:

Load Type:	Strain Control
Load History Data:	$\dot{\epsilon}_{22} = 0.01$ $\dot{\epsilon}_{33} = 0.0067$ , $\epsilon_{22max} = 0.015$ $\epsilon_{33max} = 0.01$ , $\Delta t_{constant} = 0.015$
Micromechanics model:	Double Periodic
Fiber Packing Arrangement:	Square Pack at 35% fiber volume ratio
Integration Algorithm:	Forward Euler
Constituent Material Model:	Elastic

test of biaxial load

```
*PRINT
  NPL=7 %
*LOAD
  LCON=2 LOP=7 LSS=1 %
*MECH
  NPTW=2 TI=0.,1.5 LO=0.,0.015
  NPTW=2 TI=0.,1.5 LO=0.,0.010 %
*TREF
  TREF=900. %
*MODEL
  MOD=1 %
*SOLVER
  NTF=1 NPTS=2 TIM=0.,1.5 STP=0.015 %
*FIBER
  NFIBS=1
  NF=1 MF=4 MAT=B IDB=n &
  EL=58.E3,58.E3,0.32,0.32,23.2E3,2.1E-06,2.1E-06 &
  VI=0.8E-9,1.E20,0.1E-5,0.,0.85E-4,0.05,1.,1.,1.,3.3,1.8,1.35,1.,0.01 %
*MATRIX
  NMATX=1
  NM=1 MM=4 MAT=A IDB=y %
*MRVE
  IDP=1 VF=0.35 %
*CURVE
  NP=1 %
*MACRO
  NT=2
  NC=1 X=1 Y=7 NAM=biaxl
  NC=2 X=2 Y=8 NAM=biact %
*END
```

## 13.0 Appendix H

### Sample Input File For A User Defined Material Model

The following example is used to explain the control blocks in more detail.

#### Problem Summary:

Load Type:	Stress Control
Load History Data:	$\dot{\sigma} = 0.01$ ksi/sec, $\sigma_{max} = 45.$ , $\Delta t_{constant} = 1.125$
Micromechanics model:	$[\pm 45]_s$ Laminate with Double Periodicity
Fiber Packing Arrangement:	Square Pack at 45% fiber volume ratio
Integration Algorithm:	Forward Euler
Constituent Material Model:	Bodner-Partom using user subroutine USRMAT
Constituents:	Fiber: Boron Matrix: Aluminum

☞ **Note:** This problem is the same as that given in Appendix D. The purpose here is to demonstrate how to use the USRMAT option.

use of usrmat for a [+45]2s laminate strain control problem

```
*PRINT
  NPL=0 %
*LOAD
  LCON=2 LOP=1 LSS=2 %
*MECH
  NPTW=2 TI=0.,4500. LO=0.,45. %
*TREF
  TREF=0. %
*MODEL
  MOD=3 MATSYS=1 NLY=4 THK=0.25,0.25,0.25,0.25 ANG=45.,-45.,-45.,45. %
*SOLVER
  NTF=1 NPTS=2 TIM=0.,4500. STP=1.125 %
*FIBER
  NFIBS=1
  NF=1 MS=1 MF=99 NPE=7 EL=58.E3,58.E3,0.2,0.2,24.17E3,6.3E-6,8.28E-6 &
  NPV=6 VI=0.,1.,1.,1.,1.,1. %
*MATRIX
  NMATX=1
  NM=1 MS=1 MM=99 NPE=7 &
  EL=9.53E3,9.53E3,0.33,0.33,3.58E3,21.06E-6,21.06E-6 &
  NPV=6 VI=1.E4,49.,63.,300.,4.,1. %
*MRVE
  IDP=1 VF=0.45 %
*CURVE
  NP=10 %
*MACRO
  NT=1
  NC=1 X=1 Y=7 NAM=apdxg %
*END
```

The USRMAT subroutine

The USRMAT subroutine is used here to implement the Bodner-Partom Visco-plastic model currently available in **MAC**

#####

SUBROUTINE USRMAT(DSA,SA,PE,PV,  
& TIME,TSTEP,CTEMP,DTEMPR,TREF,NIO,NPE,NPV,NCE)

c  
c purpose: user material model  
c  
c note: 1) in this subroutine, [sa] and [dsa] contain the  
c "micro" quantities for aboudi's micromechanics model  
c

c 2) arrangement of [dsa] & [sa] arrays

variable	location
strain rate	(1-6)
-----	
stress rate	(7-12)
-----	
inelastic	
strain rate	(13-18)
-----	
12 "slots"	(19-30)
for state variables	
-----	
thermal strain rate	(31-36)
-----	

c  
c  
c IMPLICIT DOUBLE PRECISION (A-H,O-Z)

C DIMENSION DSA(36),SA(36),PE(NPE),PV(NPV)

c-----  
c default user supplied material routine  
c-----

c  
c-----  
c DIMENSION SS(6),S(6),R(6)

c



```

c  write(nio,*) 'bodner: ctemp ',ctemp,' time ',time
c-----
c  extract appropriate viscoplastic material constants
c-----
      D0 = PV(1)
      Z0 = PV(2)
      Z1 = PV(3)
      BM = PV(4)
      AN = PV(5)
      Q  = PV(6)
c-----
c  copy stress from [sa] to [s]
c-----
      SS(1) = SA(7)
      SS(2) = SA(8)
      SS(3) = SA(9)
      SS(4) = SA(10)
      SS(5) = SA(11)
      SS(6) = SA(12)
c-----
c  compute the deviatoric stress [s] in the subcell
c-----
      TEMP = (SS(1) + SS(2) + SS(3))/3.
      S(1) = SS(1) - TEMP
      S(2) = SS(2) - TEMP
      S(3) = SS(3) - TEMP
      S(4) = SS(4)
      S(5) = SS(5)
      S(6) = SS(6)
c-----
c
c-----
      AJ2=0.5*(S(1)**2+S(2)**2+S(3)**2)+S(4)**2+S(5)**2+S(6)**2
      SQ3AJ = DSQRT( SS(1)**2 + SS(2)**2 + SS(3)**2 +
&                2*(SS(4)**2+SS(5)**2+SS(6)**2) )
      SQ2=1.414215
      IF(SQ3AJ.EQ.0.) THEN
      CALL ZEROR(R,6)
      ELSE
      R(1) = SS(1)/SQ3AJ
      R(2) = SS(2)/SQ3AJ
      R(3) = SS(3)/SQ3AJ
      R(4) = SQ2*SS(4)/SQ3AJ
      R(5) = SQ2*SS(5)/SQ3AJ
      R(6) = SQ2*SS(6)/SQ3AJ
      ENDIF

```

```

c-----
c if d0=0 then assume elastic and zero-out
c [dsa(13-30)] (inelastic strain rate and
c internal variable rates), then return
c-----
      IF(D0.EQ.0) THEN
      DO 100 JJ=13,30
      DSA(JJ) = 0.0
100  CONTINUE
      RETURN
c-----
c inelastic
c-----
      ELSE

C
      ZEF = Z0 + Q*SA(20) +
& (1-Q)*(R(1)*SA(21)+R(2)*SA(22)+R(3)*SA(23)+
& R(4)*SA(24)+R(5)*SA(25)+R(6)*SA(26))

C
      IF(AJ2 .EQ. 0.) THEN
      AL=0.0
      ELSE
      ARG1=ZEF**2.0/(3.*AJ2)
      CON=.5*(AN+1.)/AN
      ARG=CON*(ARG1)**AN
      AL=D0/(DEXP(ARG)*DSQRT(AJ2))
      ENDIF
c-----
c inelastic strain rates
c-----
      DSA(13) = AL*S(1)
      DSA(14) = AL*S(2)
      DSA(15) = AL*S(3)
      DSA(16) = 2*AL*S(4)
      DSA(17) = 2*AL*S(5)
      DSA(18) = 2*AL*S(6)
c-----
c plastic work rate
c-----
      WPD = S(1)*DSA(13) + S(2)*DSA(14) + S(3)*DSA(15) +
& S(4)*DSA(16) + S(5)*DSA(17) + S(6)*DSA(18)
c-----
c state variable rates
c-----

```

```
DSA(19) = WPD  
ZOM=BM/Z0  
ZD=ZOM*(Z1-ZEF)*WPD  
DSA(20)=ZD
```

C

```
DSA(21)=ZD*R(1)  
DSA(22)=ZD*R(2)  
DSA(23)=ZD*R(3)  
DSA(24)=ZD*R(4)  
DSA(25)=ZD*R(5)  
DSA(26)=ZD*R(6)  
ENDIF
```

c

```
RETURN  
END
```

c

```
C#####
```

# REPORT DOCUMENTATION PAGE

Form Approved  
OMB No. 0704-0188

Public reporting burden for this collection of information is estimated to average 1 hour per response, including the time for reviewing instructions, searching existing data sources, gathering and maintaining the data needed, and completing and reviewing the collection of information. Send comments regarding this burden estimate or any other aspect of this collection of information, including suggestions for reducing this burden, to Washington Headquarters Services, Directorate for Information Operations and Reports, 1215 Jefferson Davis Highway, Suite 1204, Arlington, VA 22202-4302, and to the Office of Management and Budget, Paperwork Reduction Project (0704-0188), Washington, DC 20503.

1. AGENCY USE ONLY (Leave blank)	2. REPORT DATE August 1996	3. REPORT TYPE AND DATES COVERED Technical Memorandum	
4. TITLE AND SUBTITLE Micromechanics Analysis Code (MAC) User Guide: Version 2.0		5. FUNDING NUMBERS  WU-505-63-12	
6. AUTHOR(S) T.E. Wilt and S.M. Arnold		8. PERFORMING ORGANIZATION REPORT NUMBER  E-10366	
7. PERFORMING ORGANIZATION NAME(S) AND ADDRESS(ES)  National Aeronautics and Space Administration Lewis Research Center Cleveland, Ohio 44135-3191		10. SPONSORING/MONITORING AGENCY REPORT NUMBER  NASA TM-107290	
9. SPONSORING/MONITORING AGENCY NAME(S) AND ADDRESS(ES)  National Aeronautics and Space Administration Washington, D.C. 20546-0001		11. SUPPLEMENTARY NOTES T.E. Wilt, University of Akron, Department of Civil Engineering, Akron, Ohio 44325 (work funded under NASA Grant NCC3-441); S.M. Arnold, NASA Lewis Research Center. Responsible person, S.M. Arnold, organization code 5220, (216) 433-3334.	
12a. DISTRIBUTION/AVAILABILITY STATEMENT  Unclassified - Unlimited Subject Categories 24 and 39  This publication is available from the NASA Center for AeroSpace Information, (301) 621-0390.		12b. DISTRIBUTION CODE	
13. ABSTRACT (Maximum 200 words)  The ability to accurately predict the thermomechanical deformation response of advanced composite materials continues to play an important role in the development of these strategic materials. Analytical models that predict the effective behavior of composites are used not only by engineers performing structural analysis of large-scale composite components but also by material scientists in developing new material systems. For an analytical model to fulfill these two distinct functions it must be based on a micromechanics approach which utilizes physically based deformation and life constitutive models and allows one to generate the average (macro) response of a composite material given the properties of the individual constituents and their geometric arrangement. Here the user guide for the recently developed, computationally efficient and comprehensive micromechanics analysis code, MAC, whose predictive capability rests entirely upon the fully analytical generalized method of cells, GMC, micromechanics model is described. MAC is a versatile form of research software that "drives" the double or triply periodic micromechanics constitutive models based upon GMC. MAC enhances the basic capabilities of GMC by providing a modular framework wherein 1) various thermal, mechanical (stress or strain control) and thermomechanical load histories can be imposed, 2) different integration algorithms may be selected, 3) a variety of constituent constitutive models may be utilized and/or implemented, and 4) a variety of fiber and laminate architectures may be easily accessed through their corresponding representative volume elements.			
14. SUBJECT TERMS Composites; Micromechanics; Computer code; Viscoplasticity; Deformation			15. NUMBER OF PAGES 92
17. SECURITY CLASSIFICATION OF REPORT Unclassified			16. PRICE CODE A05
18. SECURITY CLASSIFICATION OF THIS PAGE Unclassified	19. SECURITY CLASSIFICATION OF ABSTRACT Unclassified	20. LIMITATION OF ABSTRACT	



**National Aeronautics and  
Space Administration**

**Lewis Research Center**  
21000 Brookpark Rd.  
Cleveland, OH 44135-3191

Official Business  
Penalty for Private Use \$300

POSTMASTER: If Undeliverable — Do Not Return