

NASA Contractor Report 198517

Pulsed Plasma Thrusters for Small Spacecraft Attitude Control

Melissa L. McGuire
Analex Corporation
Brook Park, Ohio

and

Roger M. Myers
NYMA, Inc.
Brook Park, Ohio

August 1996

Prepared for
Lewis Research Center
Under Contracts NAS3-27600 and NAS3-27186

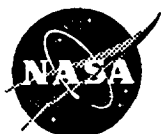

National Aeronautics and
Space Administration

PULSED PLASMA THRUSTERS FOR SMALL SPACECRAFT ATTITUDE CONTROL

Melissa L. McGuire
Analex Corporation
NASA Lewis Research Center
Cleveland, Ohio 44135

Roger M. Myers
NYMA Inc.
NASA Lewis Research Center
Cleveland, Ohio 44135

ABSTRACT

Pulsed Plasma Thrusters (PPTs) are a new option for attitude control of a small spacecraft and may result in reduced attitude control system (ACS) mass and cost. The primary purpose of an ACS is to orient the spacecraft to the desired accuracy in inertial space. The ACS functions for which the PPT system will be analyzed include disturbance torque compensation, and slewing maneuvers such as sun acquisition for which the small impulse bit and high specific impulse of the PPT offers unique advantages. The NASA Lewis Research Center (LeRC) currently has a contracted flight PPT system development program in place with Olin Aerospace with a delivery date of October 1997. The PPT systems in this study are based upon the work being done under the NASA LeRC program. Analysis of the use of PPTs for ACS showed that the replacement of the standard momentum wheels and torque rods with a PPT system to perform the attitude control maneuvers on a small low Earth orbiting spacecraft reduced the ACS mass by 50 to 75% with no increase in required power level over comparable wheel-based systems, though rapid slewing power requirements may present an issue.

1. INTRODUCTION

In this age of shrinking spacecraft size and smaller launch vehicle capacity, there is a greater need to fit more payload for more science return on a given spacecraft. For a given launch vehicle, increasing the payload mass requires a reduction of the mass and volume of the other spacecraft subsystems. Mass, volume, system complexity, reliability, and cost are critical areas in the design of a small spacecraft. Any additional subsystem increases spacecraft complexity and mass. In order to decrease spacecraft bus size or to increase the payload for a given bus, the core systems need to be made smaller and lighter. This paper presents a new option for ACS which may achieve these goals.

This study is a feasibility analysis of a Pulsed Plasma Thruster (PPT) system to perform disturbance torque compensation and deadband control for a small

spacecraft in low earth orbit (LEO). Pulsed plasma thrusters accelerate small quantities of ablated fluorocarbon propellant to generate very small impulse bits (100 to 1000 μ Ns) at high specific impulse (\sim 1000 s).¹ These characteristics make PPTs an attractive option for ACS functions. State-of-the-art attitude control systems consist of hardware such as momentum wheels, magnetic torque rods, and/or thrusters, typically hydrazine (N_2H_4), used to stabilize the spacecraft against disturbance torques resulting from either environment or spacecraft operation. The capabilities of PPTs will be examined to perform the total ACS functions in this study. Since momentum wheels are well known and trusted, replacement of the magnetic torque rods or thrusters in dumping the momentum wheels, or replacement of two of the three momentum wheels used in 3-axis stabilization are also viable options for the use of PPTs and will be left as topics of further studies.

Section two of this paper will present a background of attitude control functions as well as a baseline of current

ACS. Section three offers a description of PPTs with information about present and future ground test demonstrations and brief history of the PPT program. With this material, the analysis in section four presents the results of using PPTs to perform both the momentum compensation in place of wheels and slewing maneuvers. Finally, section five summarizes the conclusions of this preliminary feasibility analysis.

2. ATTITUDE CONTROL SYSTEMS

The attitude control system of a spacecraft stabilizes and orients it in the desired direction and to the desired fidelity as dictated by the mission. Disturbances which threaten to corrupt this attitude arise from the environment around the spacecraft (gravity-gradient, solar pressure, magnetic field interactions, and atmospheric drag) as well as from the spacecraft itself (propellant sloshing, thruster misalignment, and offsets between the center of gravity and center of pressure).² The wheels counter the angular momentum induced by these torques through spinning, while thrusters are fired to balance the external torques.²

A typical ACS in use today consists of four wheels (three primary and one backup to cover three axes), an electronics unit, and a wheel desaturation system. The latter can be either magnetic torque rods which use an electric current to produce a magnetic field which interacts with the earth's magnetic field to produce a torque, or hydrazine thrusters which produce a force that acts on a moment arm on the spacecraft also to produce a torque. Four wheel, three-axis systems for attitude control can be massive and high volume, and have suffered from reliability problems. As one example, the ESA (European Space Agency) spacecraft SOHO (Solar and Heliospheric Observatory) experienced difficulties with its momentum wheels which threatened the impending launch date. The wheels had to be replaced completely.³

Two examples of current small spacecraft and their ACS hardware are the TOMS-EP (Total Ozone Mapping Spectrometer - Earth Probe), and the WIRE (Wide Field Infrared Explorer). The TOMS-EP spacecraft is part of the Mission to Planet Earth and will measure the ozone and sulfur dioxide content of the atmosphere for a minimum of two years. WIRE is a part of the SMEX (SMall EXplorer) project and its four month mission is to study galaxy evolution through the use of cryogenically cooled telescopes and infrared detectors.⁴

A breakdown of the components and masses of the TOMS-EP and WIRE spacecraft are presented in Table 2-1.⁵ The attitude control systems represent a large fraction of the dry mass of the two spacecraft. For comparison, the TOMS-EP system the ACS, including 72.6 kg of hydrazine onboard, is 20% of the total spacecraft dry mass. For the WIRE spacecraft, with its shorter lifespan, the ACS represents 10% of the dry mass. These examples show that the ACS can be a significant percentage of the total spacecraft mass depending upon the specific mission.

3. PULSED PLASMA THRUSTERS

Pulsed plasma thrusters are currently under development for a wide range of functions including attitude control. PPTs rely on the Lorentz force generated by the interaction of an arc passing from anode to cathode with the self-induced magnetic fields to accelerate a small quantity of ablated chlorofluorocarbon propellant. As shown in Figure 3-1, the thruster system consists of the accelerating electrodes, energy storage unit, power conditioner, ignition circuit, propellant feed system, and telemetry. During operation, the energy storage capacitor is first charged to between 1 and 2 kV. The ignition supply is then activated to generate a low density plasma which permits the energy storage capacitor to discharge across the face of the fluorocarbon propellant bar. This arc ablates, heats, and accelerates the propellant to generate thrust. Peak arc current levels are typically between 5 and 15 kA, and the arc duration is between 5 and 20 μ s. The pulse cycle is repeated at a rate compatible with the available spacecraft power, which for ACS applications would likely be well below 10 W. The ability to use the same thruster over a wide range of spacecraft power levels without sacrificing performance or having a complex throttling algorithm is one of the advantages of PPTs. The propellant feed system consists solely of a negator spring which pushes the solid fluorocarbon bar against a stop on the anode electrode, eliminating safety and reliability concerns with valves or pressurized systems. There are no other moving parts on the PPT, resulting in a propulsion system which is extremely inexpensive to integrate onto spacecraft and can be stored indefinitely with little concern for storage environment. The latter was recently demonstrated when PPTs stored for over 20 years in an uncontrolled environment were successfully fired at both the NASA Lewis Research Center (LeRC) and the Olin Aerospace Company (OAC). The largest

mass components of the PPT are the energy storage unit (a capacitor or pulse-forming network) and the system electronics, including the power conditioning unit, discharge initiation, and logic and telemetry circuits. Recent developments in these technologies provide several options which can result in a system mass reduction by a factor of two.

PPTs were extensively developed in the late 1960's and early 1970's. Figure 3-2 shows the range of impulse bits demonstrated on flight or flight-qualified systems. The PPT system developed during that period with the most flight experience was used on the Navy's TIP/NOVA navigation satellites and operated at a peak power level of 30 W during firing. The NOVA PPT had a specific impulse (I_{sp}) of 543 s, an impulse bit of 400 μ N-s, a total impulse capability of 2450 N-s, and a fueled system mass of 6.8 kg.⁶ The baseline technology for the ongoing NASA program is the flight-qualified LES 8/9 PPT system, which was selected because of its higher I_{sp} of 1000 s and demonstrated total impulse capability of 10,500 N-s and over 10^7 pulses.⁷ The LES 8/9 operated at power levels of 25 or 50 W, produced an impulse bit of 300 μ N-s, and had a fueled system mass of 6.7 kg.⁸

The immediate NASA program objectives are to develop a flight PPT system by October 1997 with a fueled system mass of 3.5 kg capable of providing a total impulse of 20,000 N-s. The flight system is being built by Olin Aerospace. The factor of two mass reduction and total impulse improvement over the LES 8/9 baseline will be accomplished via use of recently developed capacitors, integrated circuit technology for both telemetry and power electronics, new structural materials, and an increase in PPT performance. The projected flight system component masses are 0.85 kg for capacitor, 0.89 kg for electronics and cabling, 0.53 kg for structure and electrode assembly, and 1.23 kg for fluorocarbon fuel. The system is to be qualified for 2×10^7 pulses. Following completion of the initial program, an effort is planned to continue miniaturizing the PPT if there is sufficient interest in the small spacecraft community.

For the ACS function, a single electronics unit could be used to charge capacitor/thruster units placed in appropriate locations (selected to provide required torques) about the spacecraft. While this option would reduce system mass significantly, for this study a complete PPT system was assumed to be located with

each thruster set, with a maximum of three thrusters per capacitor/electronics unit. The three thrusters would be oriented to thrust perpendicular to one another, providing control on all three axes. In this study, three levels of PPT technology were included: the LES 8/9 baseline, the lightweight, higher performance PPTs currently under development, and a higher I_{sp} system which could be built under a future program and is well within the demonstrated capabilities of laboratory thrusters.

The dry mass of the LES 8/9 PPTs using three thrusters about a shared capacitor is assumed to be 5.2 kg (Table 3.1). For the near term advanced technology thrusters having I_{sp} 1000 to 1500 sec, the dry mass for the same configuration is assumed to be 2.7 kg. The next generation advanced PPT with a higher I_{sp} of 2000 sec is assumed to have a dry mass of 5.2 kg for the same configuration. The 6 and 12 thrusters arrangements, the dry masses for the LES 8/9 through the advanced PPTs are as shown in Table 3-1.

4. ANALYSIS

This section develops a system level comparison of a PPT system and current small spacecraft ACS hardware for providing attitude control for a generic 50 to 300 kg, 30 to 150 W (total power from the solar arrays) spacecraft in a 400 km circular low earth orbit (LEO) at 0° inclination. Due to the top-level nature of this study, the worst case disturbance torques are used to model the environment of a small spacecraft in a 400 km circular orbit. The PPT propellant mass, thrust time, and average power are determined through a momentum balancing, rather than a torque balancing, perspective.

4.1 ORBITAL ASSUMPTIONS & ENVIRONMENT

The first step in the analysis is to evaluate the average disturbance torques over one orbit. Table 4-1 lists the magnitudes of environmental contributions from aerodynamic pressure torque, magnetic field interactions, solar pressure torques and gravity-gradient effects used in this analysis. From the assumed mission life of five years, the total disturbance (T_D) to the spacecraft is calculated. While the orbit is assumed to be circular 0° inclination for this analysis, for polar orbits the only change would be a decrease in magnetic torque by a factor of one-half. While important for detailed

estimates, this is within the margin in the analysis presented here. Both the momentum wheel system and PPT ACS will use these torques in sizing calculations. Following the estimation of the state-of-art ACS, two operational scenarios are presented for the PPTs. First, section 4.3 will present the results of using PPTs to replace momentum wheels in the ACS function of control against disturbance torques. Second, in section 4.4, the capabilities of the PPTs to perform slewing maneuvers will be examined.

4.2 CURRENT ATTITUDE CONTROL SYSTEM

In order to compare the PPT ACS with a typical ACS, a generic momentum wheel system with associated dumping thrusters is developed to establish its characteristics as a function of spacecraft mass and cross-sectional area. The assumptions for sizing the momentum wheel system used for comparison to the PPT system are based on storing angular momentum imparted to the spacecraft from the circular torques. The time between the dumping cycles of the wheels is established by the magnitude of the secular angular momentum. From this cyclic torque, the total angular momentum accumulated to the spacecraft over its five year lifetime is calculated. The momentum wheel system used in this study is sized to store one order of magnitude greater than this momentum over three orbits before dumping. Wheel mass and radius directly contribute to the amount of momentum the wheel is capable of storing. The larger the diameter of the wheel, the less massive it has to be to absorb the same amount of momentum. Additionally, thrusters or magnetic torque rods are needed to desaturate the wheels once they have reached their maximum speed. The mass of the baseline wheel system includes six hydrazine thrusters and propellant for desaturation, structure at 10% of the total system mass, and drive electronics at 0.9 kg per wheel. Table 4-2 shows a breakdown of the assumptions and masses of the calculated four wheel system.

To establish state-of-the-art ACS characteristics independent of specific mission requirements, off-the-shelf component specifications are used in this trade study. An example wheel, capable of running in both momentum wheel bias mode and reaction wheel mode, has a mass of 3.2 kg, height of 183.5 mm, diameter of 204.0 mm and steady state power levels of 3 to 5 W.⁸ Therefore, four of these wheels would have a mass of

12.8 kg. To size the wheel desaturation system, magnetic torque rods which provide enough torque to desaturate the wheels are assumed. Typical torque rods weigh 1.8 kg, have dimensions 64 cm length by 2.7 cm in diameter, and consume 5 W power. In order to cover all three axes, three torque rods are assumed on the spacecraft with a total mass of 5.4 kg. A typical attitude control electronics package off-the-shelf has a mass of 2.7 kg, dimensions of 195 x 170 x 110 mm, and power input of 3 W.⁹ This results in a system with mass of 21 kg, volume of 0.104 m³, and peak power level of 30 W without cabling mass, hydrazine heater or valve power, or margin. Note that this system is intermediate to the TOMS-EP and WIRE systems described in section two. Some missions require the higher momentum dumping capabilities of thrusters, which would be included in the overall mass, volume, and cost of the ACS.

4.3 PPT ACS SYSTEM

The total disturbance impulse (angular momentum) from the environment evaluated in section 4.1 is used in sizing the mass of propellant the PPT system will burn to provide the restoring impulse against the disturbances. While momentum wheels only absorb cyclical torques, the PPTs are used to cancel out all disturbances, both the cyclical (magnetic, atmospheric, gravity-gradient) and secular torques (solar pressure). All torques are factored into the total disturbance torque estimation.¹⁰ Twelve thrusters are typically used for full 6 degree of freedom (DOF) control of three-axis spacecraft using an all propulsive ACS. Figure 4-1 illustrates a scenerio for placement of the PPTs on a generic spacecraft. For example, both Magellan and Galileo used twelve thrusters for attitude control.¹¹ In cases where full redundancy is not necessary, fewer thrusters can be used, resulting in the mass of the PPT system being reduced even further. For a single string failure system, it is possible to control roll, pitch and yaw through either six dedicated or four canted thrusters. In these cases, one thruster failure will result in loss of propulsive ACS. Both Landsat 7 and TRMM use eight thrusters for redundant attitude control.¹² Twelve thrusters for full 6 DOF control and redundancy are included in this analysis. Assuming the torque is evenly distributed over time and space, the 12 thrusters located two on each face of the spacecraft see an equal amount of firing.

The thrust level required by the mission dictates the impulse bit and pulse rate of the PPT ACS system. The impulse bit and number of pulses dictate the momentum deliverable by the PPT system. The momentum imparted to the spacecraft by the PPT system should be greater than the disturbance angular momentum (H_D). H_D is the angular momentum accumulated between pulses from the PPT system. The total angular momentum (H_T) during the lifetime of the mission is calculated by multiplying H_D by the total number of orbits. In the following equations T_D is the sum of both the cyclic and secular disturbance torques.² The total number of pulses can also impact on lifetime issues of the PPTs.

For this analysis, the total momentum is assumed to be evenly distributed across all three axes allowing each thruster to see an equal amount of firing. Thus, for the pulsed thruster, the number of required pulses per thruster for the entire mission is:

$$\left(\frac{\text{pulses}}{\text{thruster}} \right)_T = \frac{H_T}{n \cdot I_b \cdot L}$$

Here I_b is the impulse bit of the thruster (in N-s), L is the moment arm (in m), n is the number of thrusters. The propellant mass per thrusters is given by:

$$m_p = \frac{I_b}{I_{sp} \cdot g} \left(\frac{\text{pulses}}{\text{thruster}} \right)_T$$

Here I_{sp} is the specific impulse and g is the standard acceleration due to gravity. The total mass of propellant is independent of the number of thrusters placed on the spacecraft. With more thrusters, the time of operation per thruster decreases, but the total torque to balance the disturbance does not change. Thrust time of the PPT system is:

$$\Delta t = n \cdot \frac{H_T}{L \cdot n \cdot I_b \cdot \text{pps}}$$

The total thrust time of the PPT system is also independent of the number of thrusters. More thrusters result in the duty cycle of each thruster being shortened. The energy necessary to balance the disturbance impulse is constant for a given mission. The total energy of the maneuver is independent of the number of thrusters, I_{bit} ,

or pulse frequency. However, the latter two variables drive the peak operating power of the PPT system. In addition, the PPT pulse rate (pps) and impulse bit directly affect the thrust time to complete a maneuver. The pulse rate of the thruster firing directly impacts the amount of time spent in thrust during the lifetime of the mission. Lower pulse rates will result in more time of the mission spent thrusting at a lower power level. Likewise, higher pulse firing rates will lessen the time spent thrusting at a higher power level.

The above equations were used to size the PPT ACS for spacecraft with varying mass and cross sectional area. For increasing spacecraft mass, the density was held constant resulting in an increase in spacecraft volume (thus cross-sectional area for drag calculations) with increased spacecraft mass. The spacecraft power level influenced cross-sectional area of the arrays and, consequently, the disturbance torques from the atmosphere and solar pressure.

Spacecraft mass does not influence the levels of the environmental disturbance torques as much as a change in spacecraft cross-sectional area for the baseline configuration. Increase in power requires an increase in solar array area, which in turn results in higher solar pressure and atmospheric drag contributions. Other factors such as a change in spacecraft geometry from the addition of antennae, booms, etc., can also contribute to an increase in cross-sectional area. For the purpose of this study, the spacecraft bus was simplified and only the arrays significantly change the cross-sectional area. The solar array aspect ratio and area are based on the Solar Electric Propulsion Stage (SEPS) array technology (66 W/kg).¹³ Figures 4-2 and 4-3 show the ACS system masses (both wheel and PPT) for disturbance impulse balancing as a function of spacecraft mass and cross-sectional area respectively. As shown in figure 4-2, the mass of the ACS system which absorbs the increase in momentum caused by the increase in cross-sectional area must increase. The momentum wheel system mass increases as the physical size of the spinning mass increases to absorb the increased disturbance momentum. In the PPT system, an increase in momentum translates to an increase in propellant and thrust time.

The first comparison between the baseline wheel system and the PPT system for momentum compensation is mass. It can be seen in Figures 4-2 and 4-3 that the PPT attitude control system (12 kg) for disturbance

torque compensation is 50% to 25% of the mass of the momentum wheel system (20-40 kg) for varying spacecraft mass. In the case of varying spacecraft cross-sectional area, the PPT ACS mass is 50% to 12% of the mass of the momentum wheel system (20-80 kg).

The energy of the PPT operation in the maneuver determines the power requirements to this subsystem. The energy per pulse (E_p) multiplied by the number of pulses per second defines the average power of the PPT system. Peak power levels while the PPTs are firing are directly related to impulse bit and pulse rate at which they are operating. A maneuver requiring more thrust will also require a higher power level.

In order to determine whether this is a reasonable system from the standpoint of operation and lifetime of the PPTs, the number of pulses and power levels of the PPTs to perform the momentum balancing is calculated. The number of pulses per thruster increases as the amount of disturbance angular momentum increases. At the low end (spacecraft mass 100 kg, array cross-sectional area 1.7 m²), there are 1.5x10⁶ pulses required per thruster, and at the high end (spacecraft mass 300 kg, and array cross-sectional area 3.2 m²) the number of pulses required per thruster is 3.18x10⁶. Both are well under the expected life of 10⁷ pulses. The average power consumed by the PPT system for angular momentum compensation throughout the five year life of the spacecraft is constant for a given spacecraft configuration (mass and cross-sectional area). An impulse bit of 580 μ Ns is used in both the PPT with I_{sp} 1000 s and I_{sp} 1500 s. For the low end mentioned previously, the average power is 0.08 W for the PPTs with I_{sp} of 1000 s, and 0.13 W for PPTs with I_{sp} of 1500 s, and 0.37 W. At the high end configuration, the average power is 0.18 W for the system with I_{sp} of 1000 s and 0.28 W for the 1500 s system. These average power numbers result in 9.42x10⁻³ and 2.01x10⁻² pulses per thruster per second respectively over the lifetime of the spacecraft. This amounts to a pulse roughly every one to two minutes. The deadband angular spacecraft drift between pulses for these two power levels is 0.03° and 0.014° respectively. Higher frequencies will result in smaller deadband angles. The average power during operation is driven by the pulse frequency at which the PPTs are fired. Higher pulse frequencies result in higher average power levels. For example, in the low end spacecraft case, a pulse frequency of 0.05 Hz results in average power

during firing of 0.9 W, where a frequency of 3 Hz results in a average power of 54.8 W. Therefore, the power consumption of the PPT system is a function of the demands of the mission.

4.4 SLEWING MANEUVERS

A second function for which the PPTs are analyzed is a slew maneuver of 360° (2 π) about one axis. Assuming that the spacecraft is in an unknown orientation and it must rotate about one axis, the maneuver is split into two PPT firing sequences in opposite directions. Two PPTs in a pure couple configuration pulse one half of the maneuver to start the rotation, and one half to stop. For slewing maneuvers in which a large angular rotation to the vehicle is required, the required PPT power levels increase as the required maneuver time decreases.

The power averaged over the entire maneuver duration is solved independent of pulse rate or impulse bit for these calculations, and is solely a function of time required for the maneuver. The following equation shows power as a function of maneuver time.

$$P_{avg} = \frac{\theta \cdot I_{sp} \cdot g \cdot I_{cm}}{\eta \cdot L \cdot (\Delta T)^2}$$

Here, θ is the slew maneuver angle, I_{sp} is the specific impulse of the PPT, g is the gravitational constant, I_{cm} is the moment of inertia of the spacecraft, η is the efficiency of the thruster system, L is the moment arm, and ΔT is the maneuver time. Therefore, a θ of 2 π is a worst case slew maneuver, and smaller angles will result in smaller average power requirements.

In the case of the complete rotation, as the time constraint is reduced, a larger torque is needed and therefore the PPT must provide either a higher impulse bit or higher pulse rate. Each of these increases results in a higher average power for the PPT system. The result is illustrated in Figure 4-4 which shows the average power levels of different I_{sp} PPTs versus the time required for a complete 360° spacecraft rotation. The spacecraft assumptions include a moment arm of 0.5 m, and moment of inertia (I_{cm}) of 80 kg-m². For maneuver time requirements of less than 10 minutes, average power levels are 200 W and greater. If more than 50 minutes is allowed to the maneuver, the average power levels are 10 W and lower. These power levels only need to be sustained during the slew maneuver and

could be supplied from batteries. From Figure 4-4, average power versus time to perform the slew maneuver, it can be seen that the lower the time, the higher the power requirement from the PPT system becomes. For maneuvers that must be performed in a minute, the PPT power reaches 10,000 W, and of course asymptotically approach infinity as the maneuver time goes to zero. However, if the times are relaxed, the PPT system become more feasible for this application. An alternate point of view of the PPT system for slew maneuvers is presented in Figure 4-5. Time of maneuver is also a function of pulse rate for varying impulse bits. Pulse rate in turn drives the average power required from the PPT system. This analysis serves to corroborate the relationship between time of maneuver and average power requirements of the PPT system.

5. CONCLUSION

This study demonstrated the feasibility of using pulsed plasma thrusters to provide the momentum levels needed to balance the disturbance torques imparted to a small (100 - 300 kg) spacecraft in LEO. Because of their high I_{sp} (1000 to 2000 sec), PPTs use a small amount of propellant to perform the equivalent maneuver of a hydrazine thruster system. The 12 thruster redundant PPT ACS configurations in this study were consistently half the mass or less of an equivalent baseline momentum wheel system. Average power levels for the attitude control functions range from 0.08 W to 0.28 W in worst case scenarios. PPT ACS systems used for environmental disturbance compensation are less massive and require lower average power than the counterpart wheel/thruster systems. Therefore, it is feasible to use PPTs to perform the momentum countering functions of momentum wheels systems.

For slewing maneuvers, the PPT system performs well for maneuvers that are given longer time to complete. Average power levels for slewing maneuvers range from 10 W or less for times of greater than 50 minutes. Maneuvers of less than 10 minutes would require larger power levels, or a different type of actuator, such as thrusters or a momentum wheel.

Further work remains in the areas of controls and torque matching in order to better model the use of PPTs for attitude control. Additionally, the area of deadband control through the use of pulsed plasma thrusters is a

next logical step in the study of the application of PPTs to small satellite attitude control.

6. REFERENCE

- ¹ Myers, Roger M., Steven R. Oleson, Melissa McGuire, Nicole J. Meckel and R. Joseph Cassidy, "Pulsed Plasma Thruster Technology for Small Satellite Missions," NASA Contractor Report 198427, November 1995; see also Proceedings of the 10th USU/AIAA Small Satellite Conference, Sept. 1995.
- ² Larson, Wiley J., and James R. Wertz (ed.), Space Mission Analysis and Design, Microcosm Inc, and Kluwer Academic Publishers, Torrance, 1992.
- ³ Selding, Peter B., "Reaction Wheel Concern Clouds Nov. 23 SOHO Launch," *Space News*, November 6-12, 1995.
- ⁴ SMEX homepage, <http://sunland.gsfc.nasa.gov/smex/smexhomepage.html>, March 27, 1996.
- ⁵ Todd Mendenhall, TRW, personal communication, August 21, 1995.
- ⁶ Brill, Y., A. Eisner, and L. Osborn, "The Flight Application of a Pulsed Plasma Microthruster; the NOVA Satellite," paper no. AIAA-82-1956, AIAA/JSASS/DGLR 16th International Electric Propulsion Conference, 1982.
- ⁷ Ebert, W.L., S.J. Kowal, and R.F. Sloan, "Operational Nova Spacecraft Teflon Pulsed Plasma Thruster System," paper no. AIAA-89-2497, AIAA/ASME/SAE/ASEE 25th Joint Propulsion Conference, Monterey, CA, July 10-12, 1989.
- ⁸ Ithaco, Inc., online catalog located at <http://www.newspace.com/industry/ithaco>, March 5, 1996.
- ⁹ Satellites International Limited, online catalog at <http://www.sil.com/space/9sacemds.html>, March 4, 1996.
- ¹⁰ Fortescue, Peter and John Stark, Spacecraft Systems Engineering, Wiley Publishers, Chichester, 1991.
- ¹¹ Carl Englebrecht, Jet Propulsion Laboratory, Personal communication, April 1, 1996.

¹² Steve Andrews, Goddard Space Flight Center, personal communication April 2, 1996.

¹³ SEPS technology developed by Lockheed Missiles and Space.

TOMS-EP		WIRE	
Wet mass	288.6 kg	Wet mass	270 kg
Dry Mass	216 kg	Dry Mass	250 kg
3 reaction wheels	27.6 kg	4 reaction wheels	14.4 kg
electronics	5.85 kg	3 torque rods	7.24 kg
3 magnetic torque rods	8.58 kg		
total ACS mass	42.03 kg	total ACS mass	21.6 kg
Mass fraction of ACS	20 %	Mass fraction of ACS	9 %

Table 2-1: Example Spacecraft Attitude Control Systems

Specifications	Current			Next Generation
	LES 8/9			
unit dry mass (kg)	5.2	2.7	2.7	5.2
6 thruster dry mass (kg)	10.4	5.4	5.4	10.4
12 thruster dry mass (kg)	20.8	10.8	10.8	20.8
total impulse (N-s)	10000	20000	20000	20000
efficiency (%)	8	16	16	16
Isp (sec)	1000	1000	1500	2000

Table 3-1: Pulsed Plasma Thruster Characteristics

Solar Pressure	Ts	1.9E-06
Aerodynamic	Ta	8.7E-05
Gravity gradient	Tg	3.9E-07
Magnetic Field	Tm	2.6E-05
Total torque:	Td	1.1E-04

Table 4-1: Magnitudes of Disturbance Torques at 400 km Altitude

Component	Value	
wheel speed	3000	rpm
disk radius	0.08	m
individual spinning mass	3.60	kg
drive electronics	0.91	kg
total structure (4 wheels)	2.00	kg
dumping thruster mass	0.4	kg
total thruster mass (6)	2.4	kg
200s Isp propellant mass	5.23	kg
280s Isp propellant mass	3.73	kg
<i>Totals: 4 wheels & 6 thrusters</i>		
Four wheel system mass	20.04	kg
six thruster 200 Isp mass	7.63	kg
six thruster 280 Isp mass	6.13	kg

Table 4-2: Four wheel system baseline assumptions

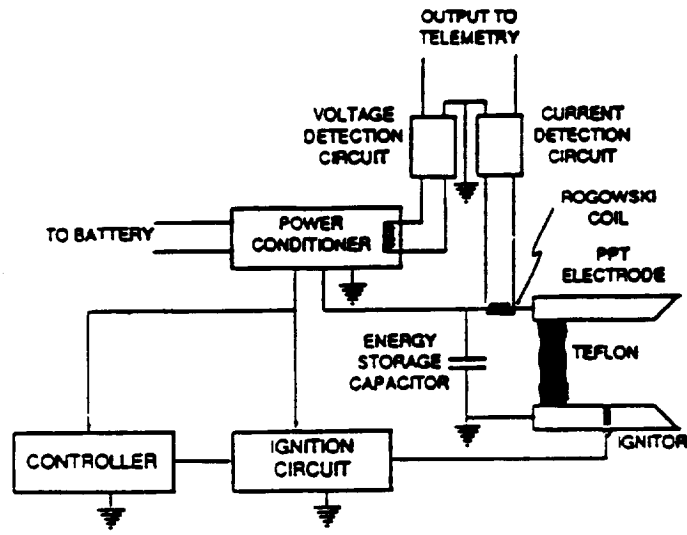

Figure 3-1: PPT flight system schematic. Telemetry signals depend on application.

ImpBit-DischEdataAeroDes

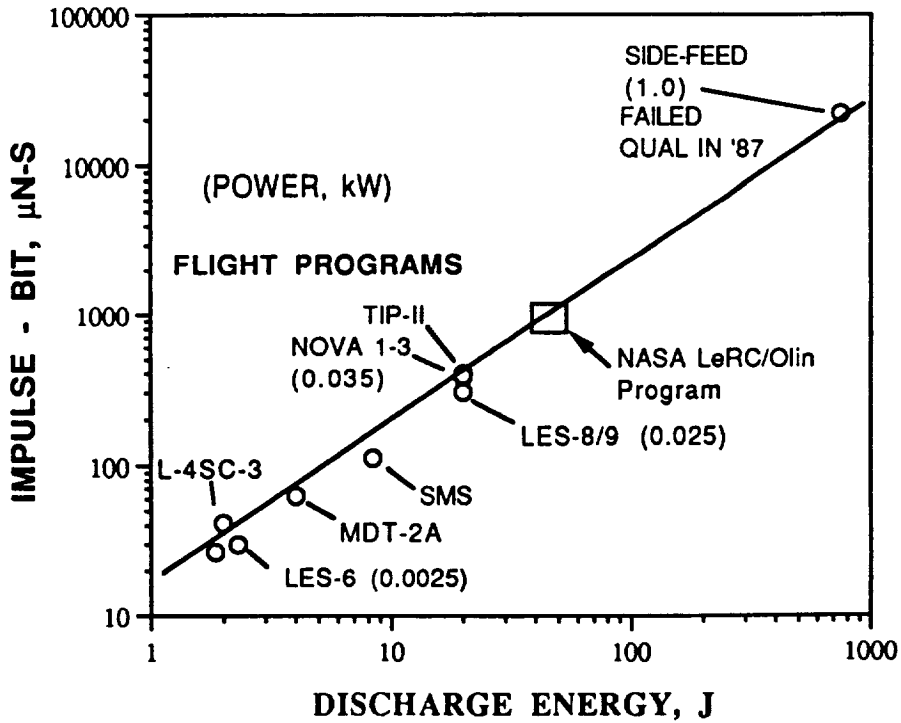
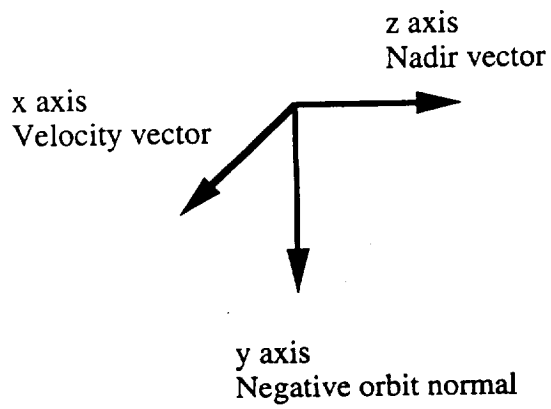

Figure 3-2: Impulse bit vs. stored energy for a range of flight and flight-qualified PPT systems.

Axes Key:



Total of 12 PPTs
Two per spacecraft face

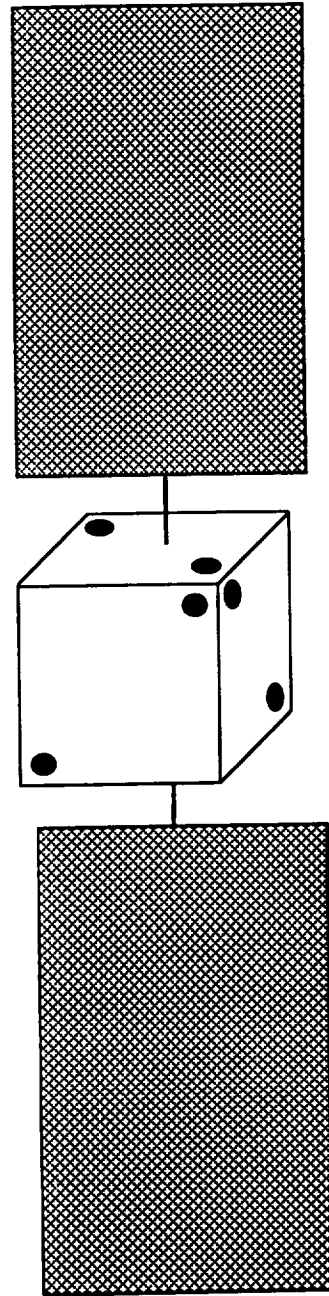

Figure 4-1: Generic Spacecraft Illustrating Pulsed Plasma Thruster Placement

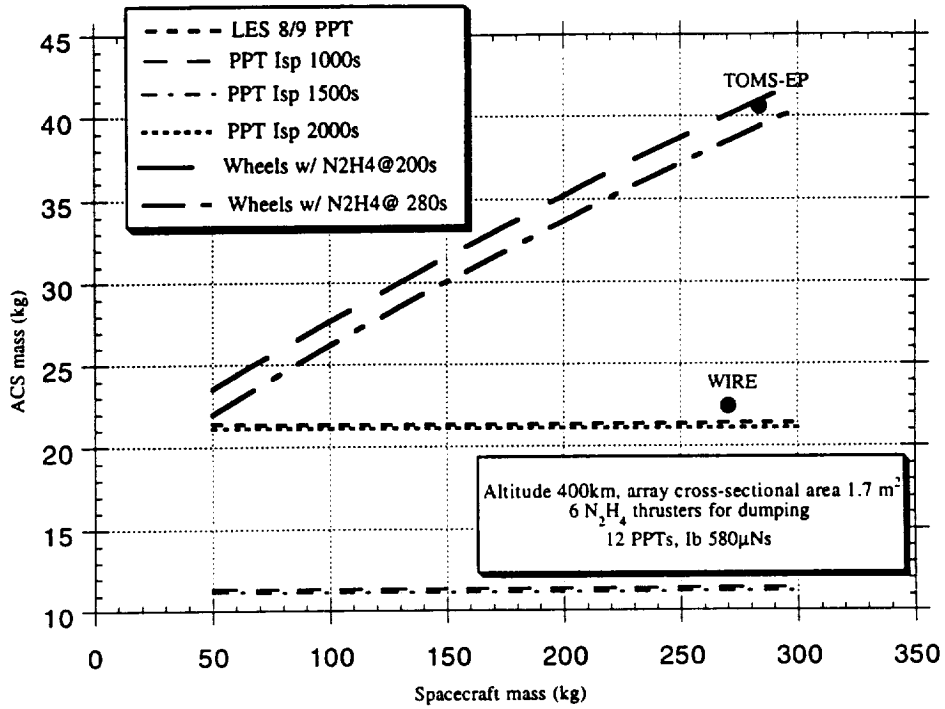

Figure 4-2: Attitude Control System Mass for Varying Spacecraft Mass

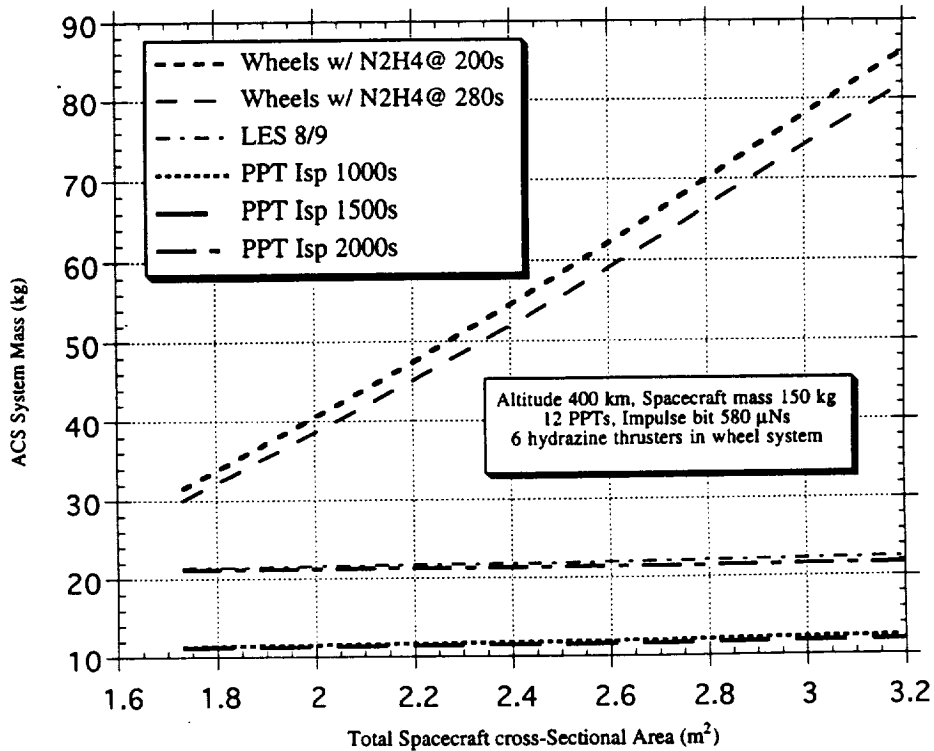

Figure 4-3: Attitude Control System Mass for Varying Array Cross-Sectional Area

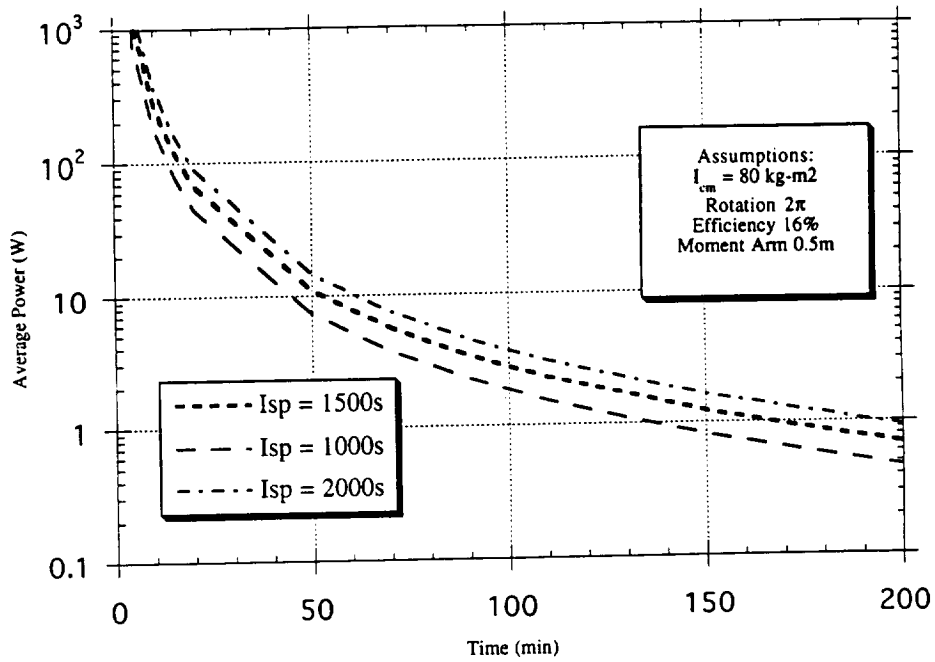

Figure 4-4: PPT System Power Levels for Time to Accomplish 2π Slewing Maneuver

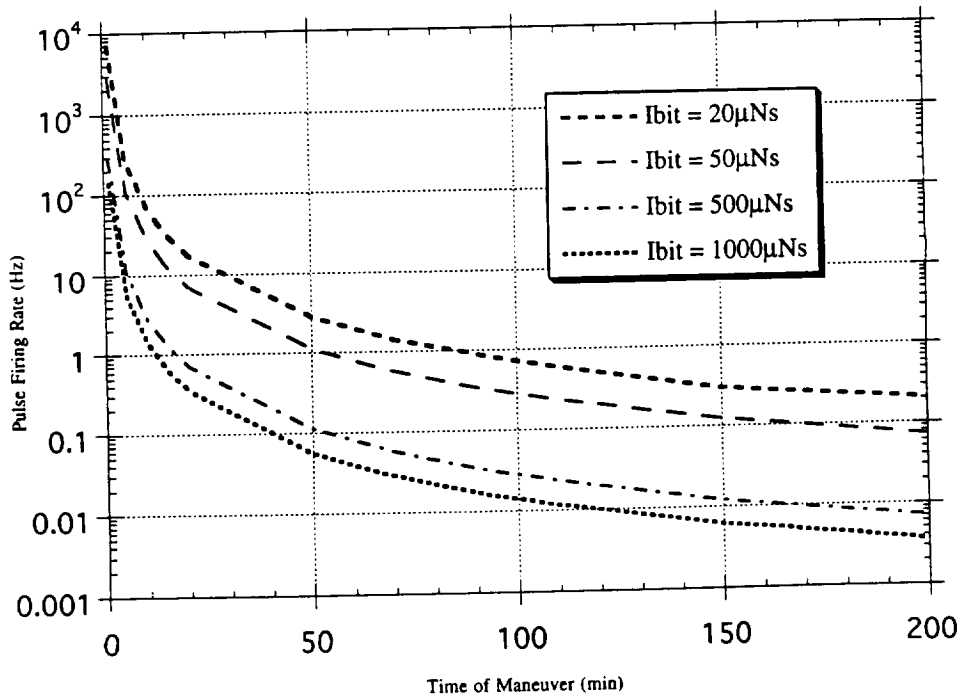

Figure 4-5: Pulse Firing Rates of Differing Impulse Bits for 2π Maneuver Times

REPORT DOCUMENTATION PAGE

Form Approved
OMB No. 0704-0188

Public reporting burden for this collection of information is estimated to average 1 hour per response, including the time for reviewing instructions, searching existing data sources, gathering and maintaining the data needed, and completing and reviewing the collection of information. Send comments regarding this burden estimate or any other aspect of this collection of information, including suggestions for reducing this burden, to Washington Headquarters Services, Directorate for Information Operations and Reports, 1215 Jefferson Davis Highway, Suite 1204, Arlington, VA 22202-4302, and to the Office of Management and Budget, Paperwork Reduction Project (0704-0188), Washington, DC 20503.

1. AGENCY USE ONLY (Leave blank)	2. REPORT DATE August 1996	3. REPORT TYPE AND DATES COVERED Final Contractor Report	
4. TITLE AND SUBTITLE Pulsed Plasma Thrusters for Small Spacecraft Attitude Control		5. FUNDING NUMBERS WU-233-03-05 C-NAS3-27600 C-NAS3-27186	
6. AUTHOR(S) Melissa L. McGuire and Roger M. Myers		8. PERFORMING ORGANIZATION REPORT NUMBER E-10395	
7. PERFORMING ORGANIZATION NAME(S) AND ADDRESS(ES) Analex Corporation 3001 Aerospace Parkway Brook Park, Ohio 44142		10. SPONSORING/MONITORING AGENCY REPORT NUMBER NASA CR-198517	
9. SPONSORING/MONITORING AGENCY NAME(S) AND ADDRESS(ES) National Aeronautics and Space Administration Lewis Research Center Cleveland, Ohio 44135-3191		11. SUPPLEMENTARY NOTES Melissa L. McGuire, Analex Corporation, 3001 Aerospace Parkway, Brook Park, Ohio 44142 (work performed under NASA Contract NAS3-27600), and Roger M. Myers, NYMA, Inc., 2001 Aerospace Parkway, Brook Park, Ohio 44142 (work performed under NASA Contract NAS3-27186). Project Manager, Sandra L. Hardy, Engineering Systems Division, NASA Lewis Research Center, organization code 4420, (216) 433-2278.	
12a. DISTRIBUTION/AVAILABILITY STATEMENT Unclassified - Unlimited Subject Categories 18 and 20 This publication is available from the NASA Center for AeroSpace Information, (301) 621-0390.		12b. DISTRIBUTION CODE	
13. ABSTRACT (Maximum 200 words) Pulsed Plasma Thrusters (PPTs) are a new option for attitude control of a small spacecraft and may result in reduced attitude control system (ACS) mass and cost. The primary purpose of an ACS is to orient the spacecraft to the desired accuracy in inertial space. The ACS functions for which the PPT system will be analyzed include disturbance torque compensation, and slewing maneuvers such as sun acquisition for which the small impulse bit and high specific impulse of the PPT offers unique advantages. The NASA Lewis Research Center (LeRC) currently has a contracted flight PPT system development program in place with Olin Aerospace with a delivery date of October 1997. The PPT systems in this study are based upon the work being done under the NASA LeRC program. Analysis of the use of PPTs for ACS showed that the replacement of the standard momentum wheels and torque rods with a PPT system to perform the attitude control maneuvers on a small low Earth orbiting spacecraft reduced the ACS mass by 50 to 75% with no increase in required power level over comparable wheel-based systems, though rapid slewing power requirements may present an issue.			
14. SUBJECT TERMS Spacecraft attitude control; Pulsed plasma thrusters; Low Earth Orbit (LEO)			15. NUMBER OF PAGES 15
17. SECURITY CLASSIFICATION OF REPORT Unclassified			16. PRICE CODE A03
18. SECURITY CLASSIFICATION OF THIS PAGE Unclassified	19. SECURITY CLASSIFICATION OF ABSTRACT Unclassified	20. LIMITATION OF ABSTRACT	

**National Aeronautics and
Space Administration
Lewis Research Center
21000 Brookpark Rd.
Cleveland, OH 44135-3191**

**Official Business
Penalty for Private Use \$300**

POSTMASTER: If Undeliverable — Do Not Return