

NASA Conference Publication 10186

231976

48.

Rayleigh Scattering Diagnostics Workshop

*Proceedings of a conference held at
NASA Lewis Research Center
Cleveland, Ohio
July 25-26, 1995*



NASA Conference Publication 10186

Rayleigh Scattering Diagnostics Workshop

*Proceedings of a workshop
held at and sponsored by NASA Lewis Research Center
Cleveland, Ohio
July 25-26, 1995*



National Aeronautics and
Space Administration

Office of Management

**Scientific and Technical
Information Program**

1996

PREFACE

The Rayleigh Scattering Diagnostics Workshop was held July 25-26, 1995 at the NASA Lewis Research Center in Cleveland, Ohio. The purpose of the workshop was to foster timely exchange of information and expertise acquired by researchers and users of laser based Rayleigh scattering diagnostics for aerospace flow facilities and other applications.

The workshop was attended by about 30 individuals from government, industry, and universities. This Conference Publication includes the 12 technical presentations and transcriptions of the two panel discussions. It should be noted that in the process of transcribing the tape recordings of the panel discussions, some mistakes have probably been made. The responsibility for these errors rests with the workshop organizer.

The first panel was made up of "users" of optical diagnostics, mainly in aerospace test facilities, and its purpose was to assess areas of potential applications of Rayleigh scattering diagnostics. The second panel was made up of active researchers in Rayleigh scattering diagnostics, and its purpose was to discuss the direction of future work.

We thank all the presenters and panel members for their excellent contributions. And we would like to acknowledge Joan Pettigrew, Barbara Mader, and Pamela Spinosi, whose efforts were essential to the success of the workshop.

Richard Seasholtz and Daniel Lesco
Workshop Organizers
Optical Instrumentation Technology Branch
NASA Lewis Research Center

TABLE OF CONTENTS

Technical Presentations	Page
RAYLEIGH IMAGING AND MEASUREMENT IN HIGH SPEED FLOWS, Keynote Paper R.B. Miles, J.N. Forkey, N. Finkelstein, and W.R. Lempert, Princeton University	1 - <i>omit</i>
FUNDAMENTALS OF RAYLEIGH-BRILLOUIN SCATTERING James Lock, Cleveland State University	39 - <i>omit</i>
ABSORPTION FILTER BASED OPTICAL DIAGNOSTICS IN HIGH SPEED FLOWS Mo Samimy, Gregory Elliott, and Stephen Arnette, Ohio State University	49 - 1
RAYLEIGH LIGHT SCATTERING FOR CONCENTRATION MEASUREMENTS IN TURBULENT FLOWS William M. Pitts, National Institute of Standards and Technology	69 - 2
VELOCITY MEASUREMENT BY SCATTERING FROM INDEX OF REFRACTION FLUCTUATIONS INDUCED IN TURBULENT FLOWS Lars Lading and Mark Saffman, Riso Research Center; and Robert Edwards, Case Western Reserve University	89 - 3
RAYLEIGH SCATTERING MEASUREMENTS IN NASA LANGLEY'S HYPERSONIC FACILITIES Richard R. Antcliff, NASA Langley Research Center	101 - 4
INVESTIGATION OF CONDENSATION/CLUSTERING EFFECTS ON RAYLEIGH SCATTERING MEASUREMENTS IN A HYPERSONIC WIND TUNNEL Charles Tyler, Wright-Patterson Air Force Base	111 - 5
DEMONSTRATION AND ANALYSIS OF FILTERED RAYLEIGH SCATTERING FLOW FIELD DIAGNOSTIC SYSTEM Joseph N. Forkey, Walter R. Lempert, and Richard B. Miles, Princeton University	123 - 6
DUAL-LINE DETECTION RAYLEIGH SCATTERING MEASUREMENTS OF DENSITY AND TEMPERATURE Kurt Annen, Aerodyne Research Corp; Volkan Otugen, Polytechnic University; and Richard Seasholtz, NASA Lewis Research Center.	141 - 7
Nd:YAG LASER-BASED DUAL-LINE DETECTION RAYLEIGH SCATTERING AND CURRENT EFFORTS ON UV, FILTERED RAYLEIGH SCATTERING M. Volkan Otugen and Svetozar Popovic, Polytechnic University	151 - 8
JET EVOLUTION VISUALIZED AND QUANTIFIED USING FILTERED RAYLEIGH SCATTERING Mark F. Reeder, National Research Council Associate, NASA Lewis Research Center	171 - 9
RAYLEIGH SCATTERING MEASUREMENTS IN NASA LEWIS WIND TUNNELS Richard Seasholtz, NASA Lewis Research Center	193 10
TRANSCRIPTION OF PANEL DISCUSSIONS	
Panel discussion 1—Assessment of potential applications of Rayleigh scattering diagnostics.	199
Panel discussion 2—Direction of future work in Rayleigh scattering diagnostics	207
List of Attendees	217 } <i>omit</i>

omit

RAYLEIGH IMAGING AND MEASUREMENT IN HIGH SPEED FLOWS

R.B. Miles, J.N. Forkey, N. Finkelstein,
and W.R. Lempert
Princeton University
Princeton, New Jersey

CATEGORY	TECHNIQUE	PROJECTION
1	A. Rayleigh Scattering	Very Promising
	B. Mie Scattering	Very Promising
2	C. Laser-Induced Fluorescence	Promising
	D. Mass Spectrometry	Promising
3	E. Thermal Emission	Needs More Research
	F. Electron-Beam Fluorescence	Needs More Research
	G. Raman Scattering	Needs More Research
4	H. Coherent Anti-Stokes Raman Scattering - CARS	Little Promise
5	I. Laser Doppler Velocimetry	Requires Seeding
	J. Resonant Doppler Velocimetry	Requires Seeding

TABLE 3. Summary of Conclusions.

EVALUATION OF NON-INTRUSIVE FLOW MEASUREMENT TECHNIQUES FOR A RE-ENTRY FLIGHT EXPERIMENT

R. B. MILES, D. A. SANTAVICCA,
AND M. ZIMMERMANN
Princeton University
Princeton, New Jersey 08544

Cooperative Agreement NCCI-64
NOVEMBER 1983

Acknowledgments

The authors gratefully acknowledge the extensive advice and comments of a large number of researchers. Most of these scientists are currently engaged in related work and all provided valuable perspective for this study.

Princeton University:

G. Bienkowski	I. Kennedy	A. Smits
S. M. Bogdonoff	M. Littman	
D. Dolling	G. Settles	

NASA/Ames:

R. McKenzie

NASA/Langley:

D. Eide	J. Jones	J. Shinn
J. Hoppe	B. Lewis	K. Sutton
W. Hunter	J. Moss	G. Wood

United Technologies, Hartford, Connecticut:

M. Colket	M. Sabielski
A. Eckbreth	D. Seery

University of California, Berkeley, California:

J. Daily	L. Talbot
----------	-----------

Sandia National Laboratory, Livermore, California:

R. Cattolica	D. Holve	R. Schefer
R. Dibble	W. McLean	J. R. Smith
M. Dyer	L. Rahn	P. Witze
W. Flower	G. Ramback	

Stanford University, Stanford, California:

D. Baganoff	R. Hansen
D. Bershader	C. Kruger

RAYLEIGH SIGNAL [HEURISTIC DERIVATION]

- Rayleigh scattering arises from a molecule with an externally-driven dipole

$$\mu = \alpha \mathcal{E}_i \cos(\omega t)$$

Radiation is proportional to the acceleration of the charged particles

$$\mathcal{E}_s \approx \omega^2 \mu \quad \text{or} \quad \mathcal{E}_s \approx \omega^2 \alpha \mathcal{E}_i$$

- The total power scattered must be independent of the distance from the dipole. Over a sphere of radius, r , around the dipole

$$P_s = \oint I_s dS = r^2 \oint I_s(r) d\Omega = \text{constant}$$

$$\text{so,} \quad I_s(r) \approx \frac{1}{r^2}$$

$$\text{and,} \quad \mathcal{E}_s(r) \approx \frac{1}{r}$$

RAYLEIGH SIGNAL [HEURISTIC DERIVATION]

- The radiated field at a particular angle must be proportional to the apparent dipole seen from that angle.

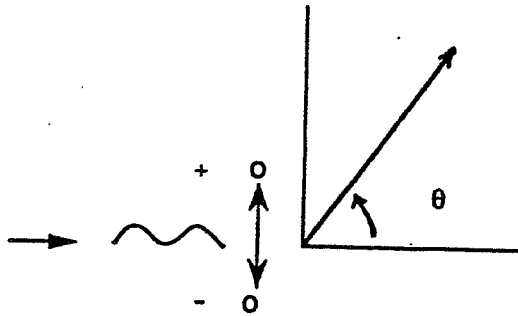

$$\mathcal{E}_r \approx \cos \theta$$

RAYLEIGH SIGNAL
[HEURISTIC DERIVATION]

(Continued)

Combining these heuristic points, we find:

$$\mathcal{E}_r \approx \frac{\omega^2 \alpha \mathcal{E}_i \cos \theta}{r}$$

Classical E & M theory gives:

$$\mathcal{E}_r = \frac{\omega^2 \alpha \mathcal{E}_i \cos \theta}{4\pi \epsilon_0 c^2 r} \quad \text{in MKS units}$$

or

$$I_r = \frac{\omega^4 \alpha^2 I_i \cos^2 \theta}{16\pi^2 \epsilon_0^2 c^4 r^2}$$

COLLECTED POWER (FROM A SINGLE DIPOLE)

$$P_c = \int_{\text{collection solid angle}} r^2 I_r d\Omega \times (\text{efficiency factors}).$$

$$= I_i \int \frac{\partial \sigma}{\partial \Omega} d\Omega \times (\text{efficiency factors}), \quad \approx \sigma I_i$$

$$\text{where: } \frac{\partial \sigma}{\partial \Omega} = \frac{\omega^4 \alpha^2 \cos^2 \theta}{16\pi^2 \epsilon_0^2 c^4}$$

$$\text{Note: } \bar{D} = \epsilon_0 \bar{E} + \bar{P} = \epsilon_0 \bar{E} + N\alpha \bar{E} = \epsilon \bar{E}$$

$$n = \sqrt{\epsilon/\epsilon_0}$$

$$\text{so, } \alpha = \frac{\epsilon - \epsilon_0}{N} \quad \text{or} \quad \frac{\alpha}{\epsilon_0} = \frac{n^2 - 1}{N} \equiv \frac{2(n-1)}{N}$$

$$\text{So, } \frac{\partial \sigma}{\partial \Omega} = \frac{\omega^4}{4\pi^2 c^4} \left[\frac{n-1}{N} \right]^2 \cos^2 \theta$$

TABLE 2. INDICES OF REFRACTION AND TOTAL
RAYLEIGH SCATTERING CROSS SECTIONS

Molecule	Index of Refraction μ	Wavelength (\AA)	σ_s (10^{-28} cm^2)	ref.
O ₂	1.000271	5893	27.90	a
N ₂	1.000296	"	33.40	a
Ar	1.000281	"	29.91	a
Ne	1.0000671	"	1.71	b
He	1.000036	"	0.49	a
H ₂	1.000132	"	6.62	a
CO ₂	1.000448	"	7.82	a
CH ₄	1.000444	"	74.73	a
CCl ₂ F ₂ (freon-12)	1.00133	5145	996.10	p
CCl ₂ F ₂ (freon-12)	1.001050	6328	31.40	c
CBrF ₃ (freon-13B1)	1.0011	5145	682.8	p
CF ₄ (freon-14)	1.000475	5145	135.72	p
CHClF ₂ (freon-22)	1.0010036	5145	605.70	p

a - ref. 46

b - ref. 47

c - ref. 24

p - present

SCATTERING VECTOR

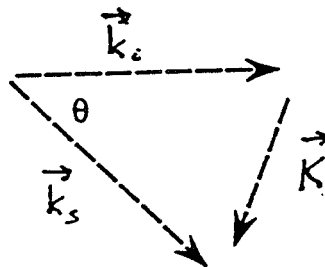
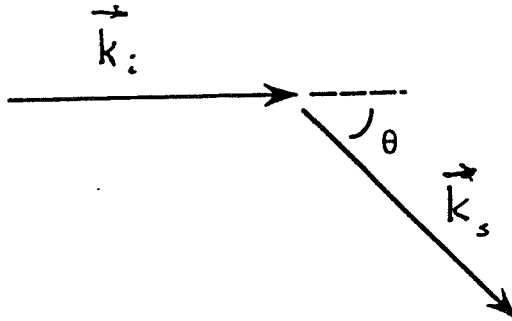

$$|\vec{K}| = |\vec{k}_i - \vec{k}_s| = \frac{2\pi}{\lambda} \left[2 \sin \frac{\theta}{2} \right]$$

Velocity sensitivity is in the \vec{K} direction.

RAYLEIGH SCATTERING LINESHAPES

- a) $y = 4.39$ [641 Torr]
- b) $y = 1.05$ [154 Torr]
- c) $y = 0.55$ [81 Torr]
- d) $y = 0.007$ [1 Torr]

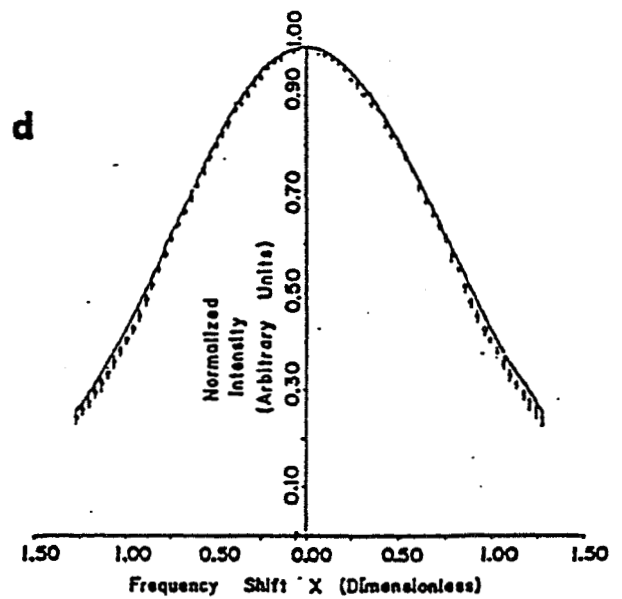
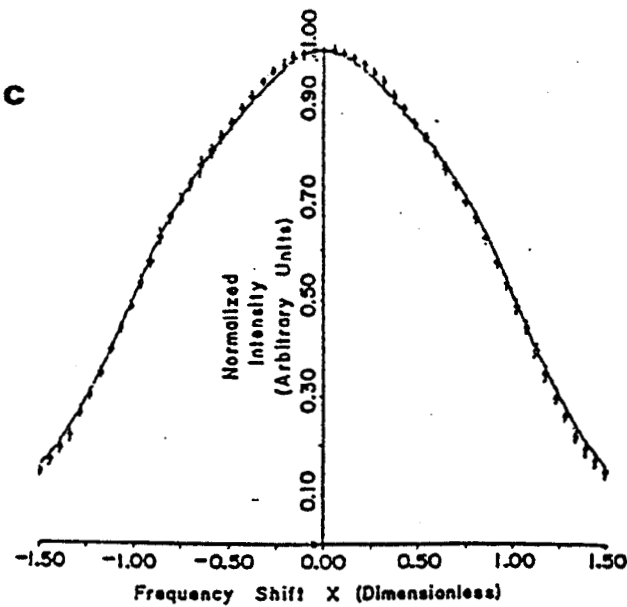
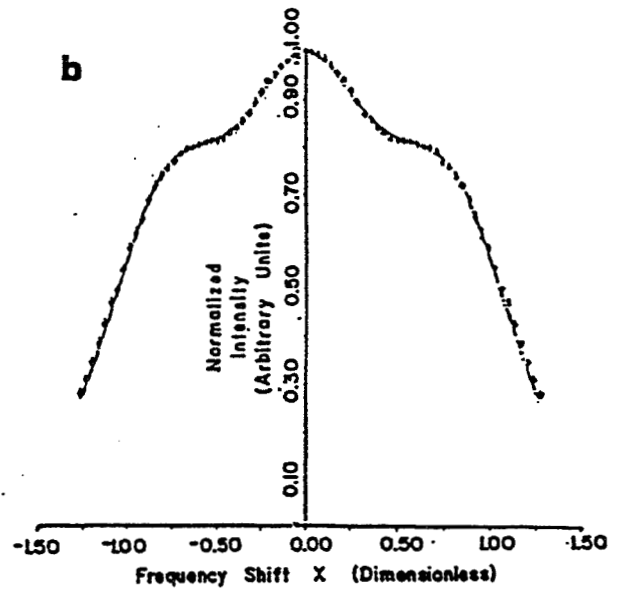
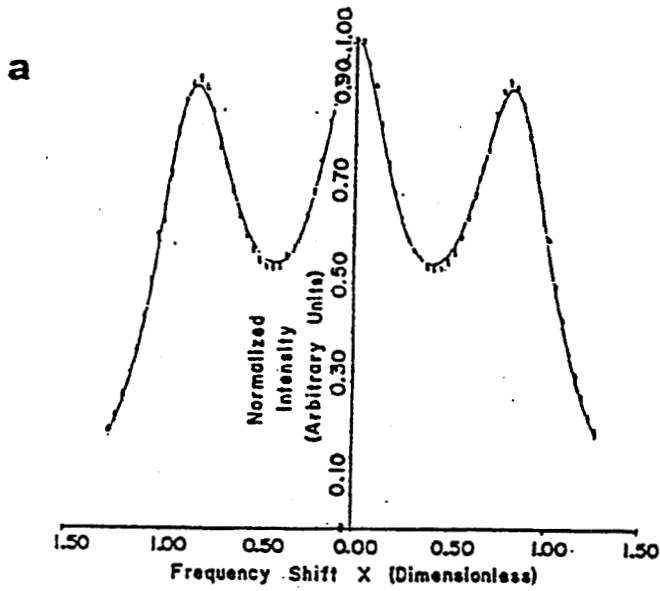

(Ref: R.P. Sandoval and R.L. Armstrong, Phys. Rev. A, 13, Feb. 1976, p. 752)

RAYLEIGH SIGNAL

- The total signal is proportional to the density.
- The linewidth is related to the temperature (and pressure).
- The frequency shift is related to the velocity in the \vec{K} direction.

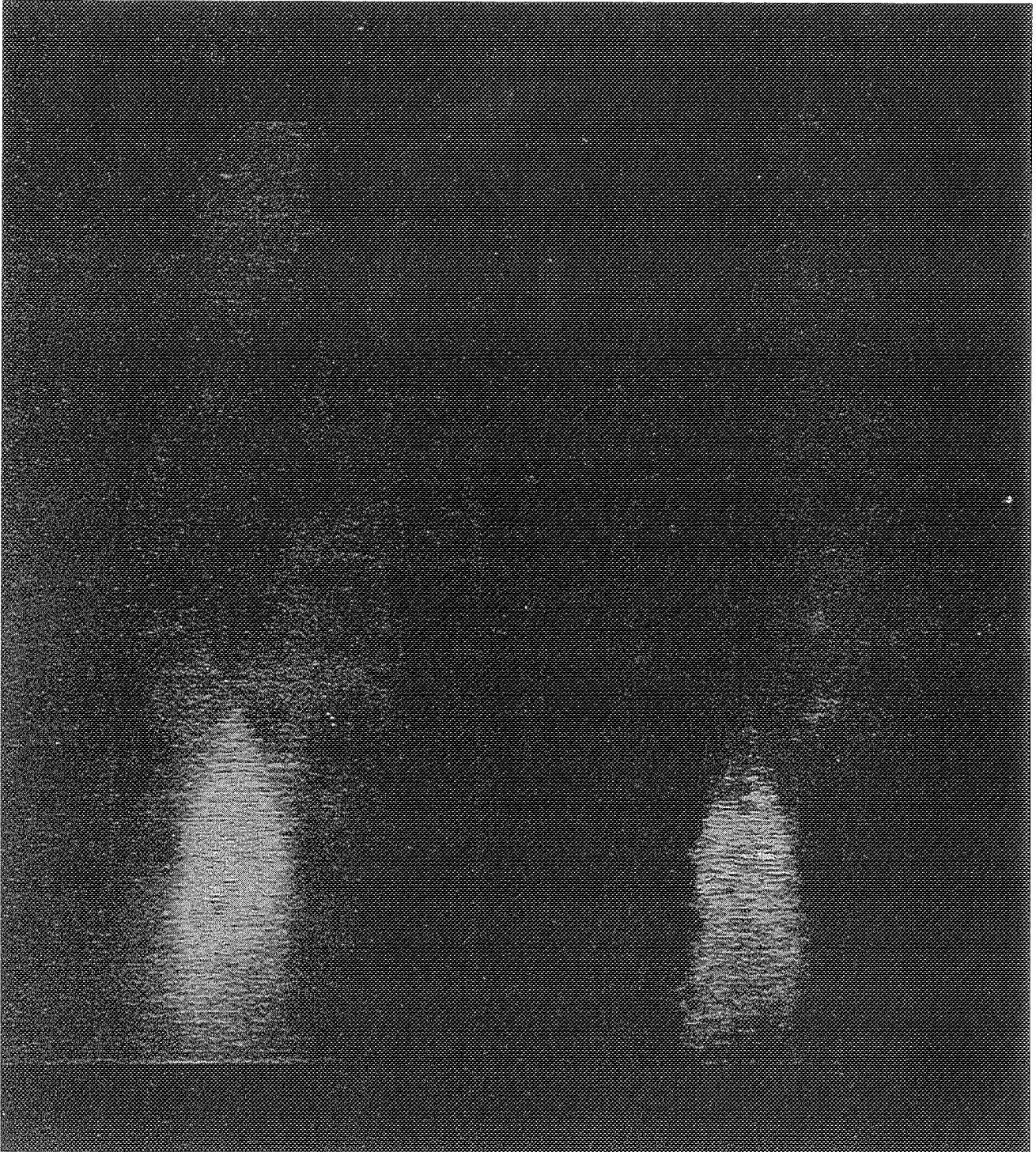

MACH 5 OVEREXPANDED JET

SCATTERING FROM PARTICLE FOG

- Fog occurs in virtually all blow-down air facilities at Mach > 2 .
- Made up of H₂O, CO₂ (?) condensed particles.
- Fog is made up of small, nanoscale particles so they are in the Rayleigh range $2\pi a \ll \lambda$.
- Fog serves as a tracer of low temperature air.
- Interface with the boundary layer is highlighted since the fog evaporates at high temperatures.
- Scattering linewidth is narrow compared to air.

DOUBLE-PULSED RAYLEIGH

- Uses a double-pulsed Nd:YAG laser (green).
[Pulse separation: 15-80 μ secs.]
- Images captured with two gated cameras or a high-speed framing camera.
- Double images give
 - boundary layer evolution.
 - dynamics of shock wave/boundary layer interactions.
 - velocity profiles.

filtered rayleigh scattering basic concept

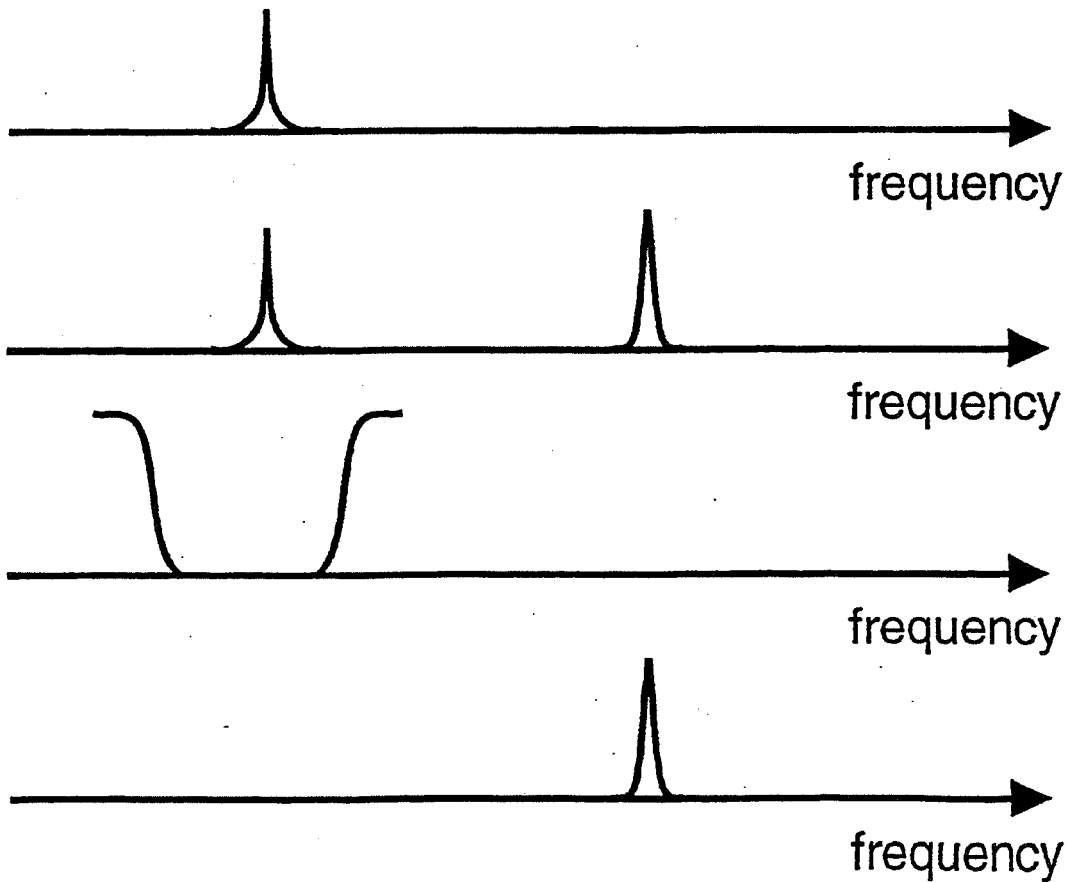
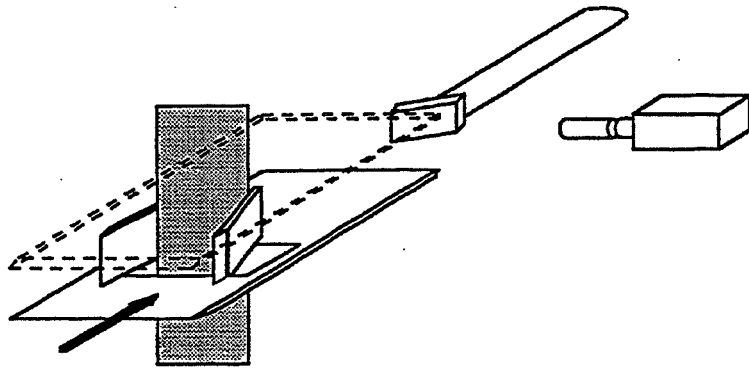

DOPPLER SHIFT

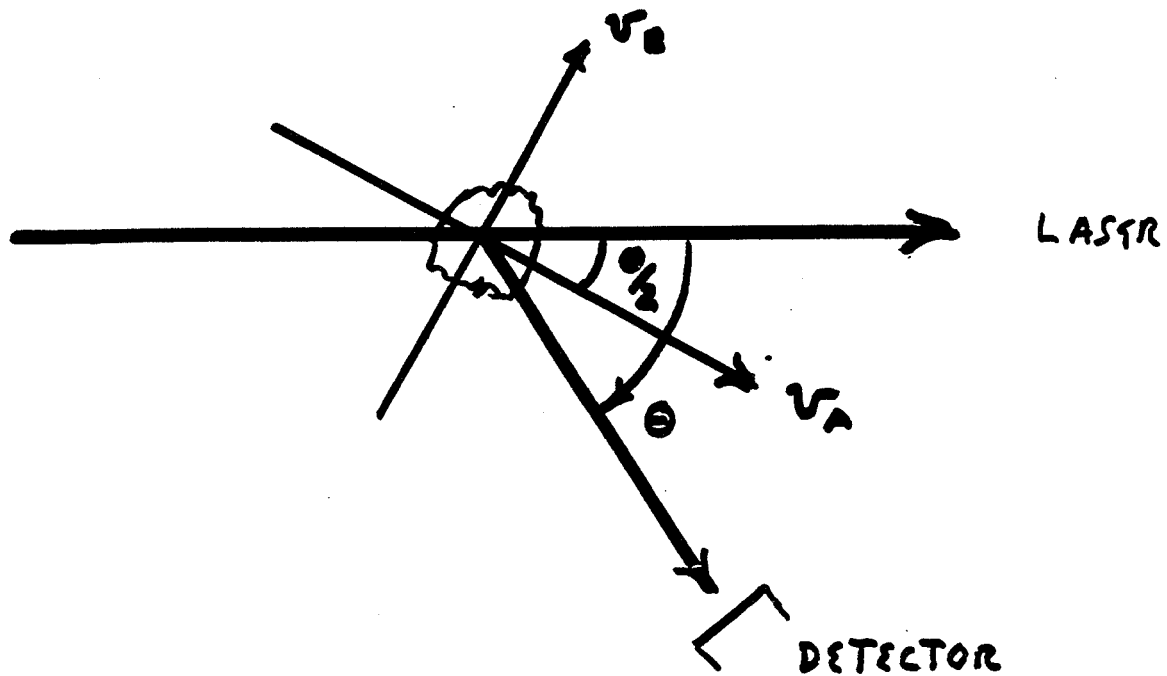

PARTICLES MOVING IN THE v_a DIRECTION
GIVE 0 DOPPLER SHIFT

PARTICLES MOVING IN THE v_b DIRECTION
GIVE

$$\Delta f = \frac{2f_0 v_b}{c} \sin(\theta/2)$$

Filter

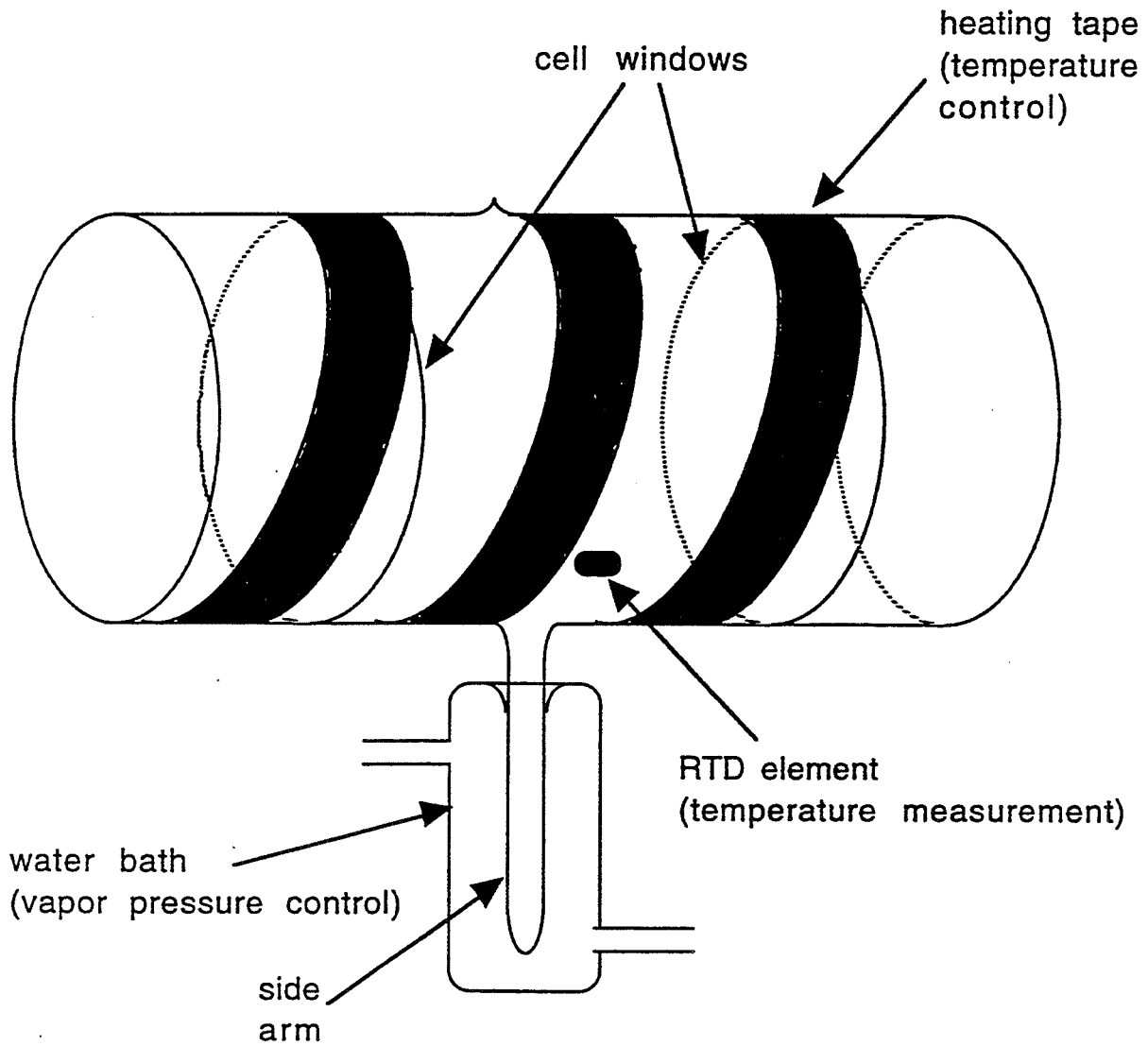

Iodine Cell Transmission Profile

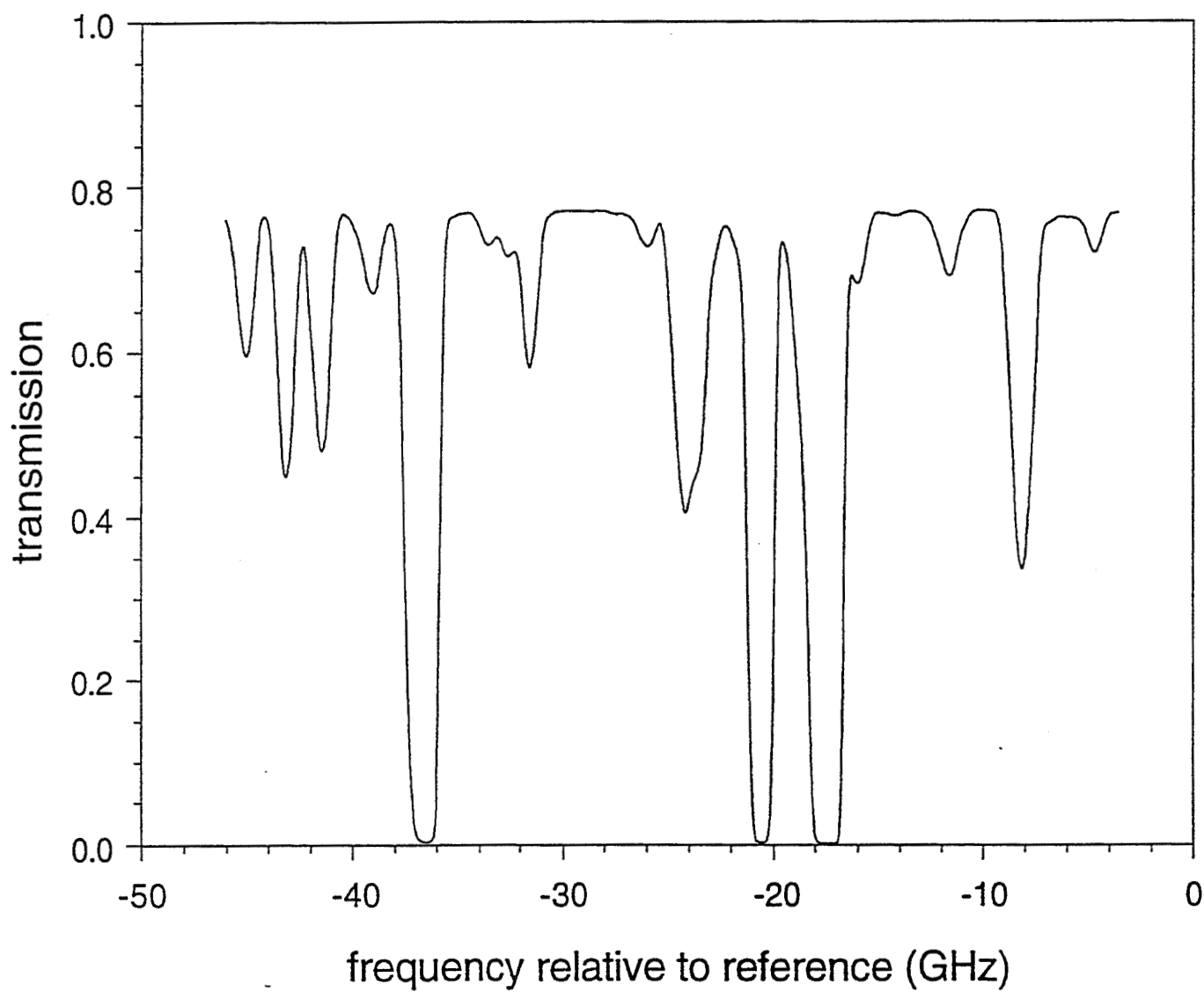

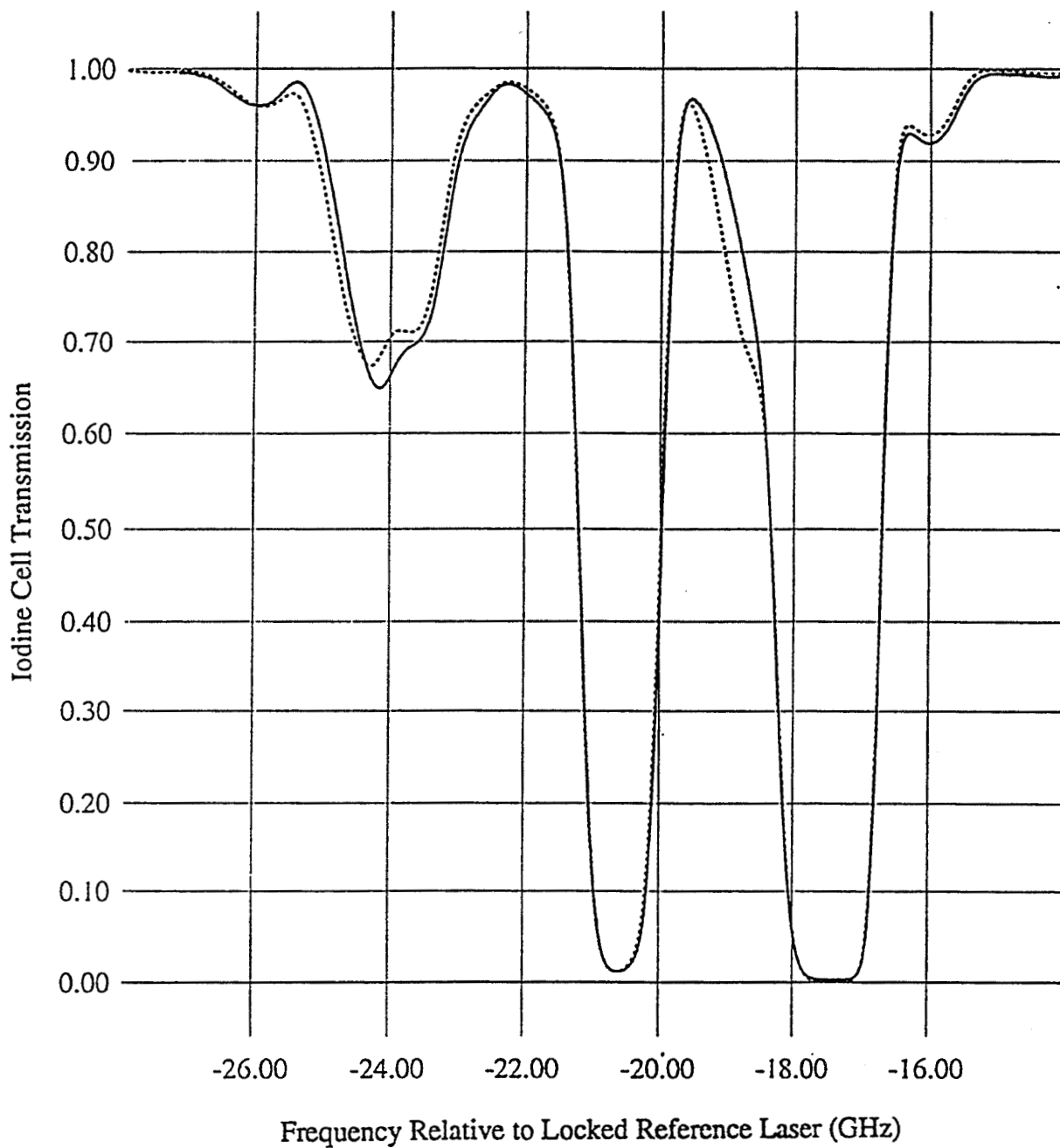
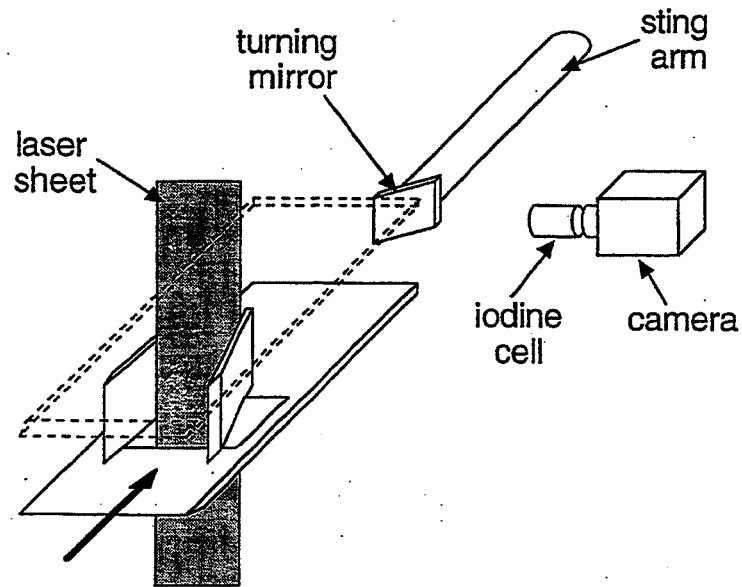
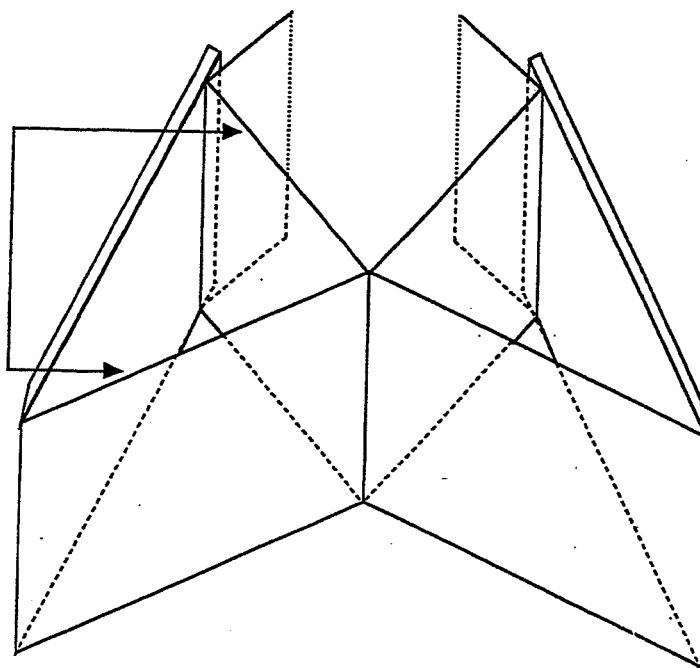

Figure 3) Comparison between data of figure 1 for a cell pressure of 0.7 torr (solid curve) and theoretical model of iodine absorption (dotted curve). Data is renormalized to 100% transmission away from absorption lines since background absorption and absorption due to windows is not included in model.

imaging setup using filtered rayleigh scattering



basic geometry of crossing shocks



tunnel parameters

- blowdown facility
- compressed atmospheric air supply
- $P_o = 100$ psi
- $T_o = 260$ K
- Mach # = 3

model parameters

- 4" vertical, 6" horizontal inlet
- ≥ 1 " separation from tunnel wall on all sides
- variable angle fins (5° to 11°)

laser parameters

- 532nm
- 5 to 7 ns pulse width
- injection seeded
- tunable over ~ 60 GHz

cell parameters

- iodine
- cell length = 3.25"
- cell diameter = 2"
- cell temperature = 80 C
- side arm temp. = 44.5 C (vapor press. = 1.44 torr)

Determination of Flow Parameters via Laser Frequency Tuning

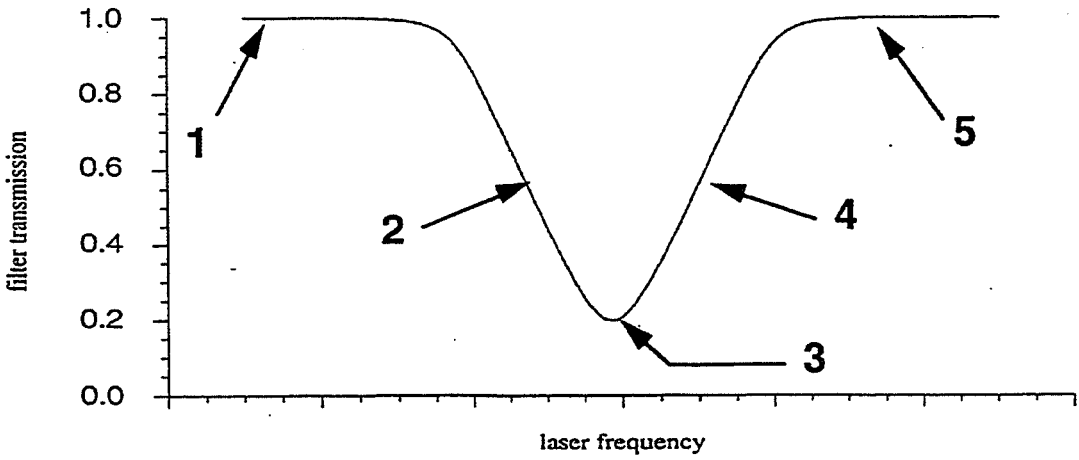
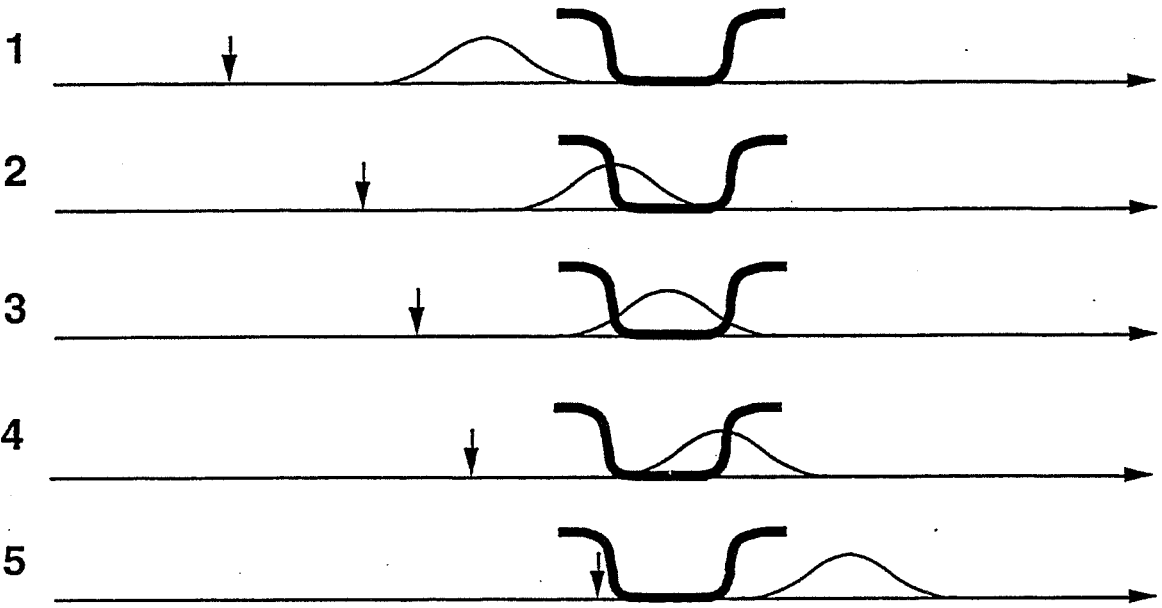

Experimental Setup

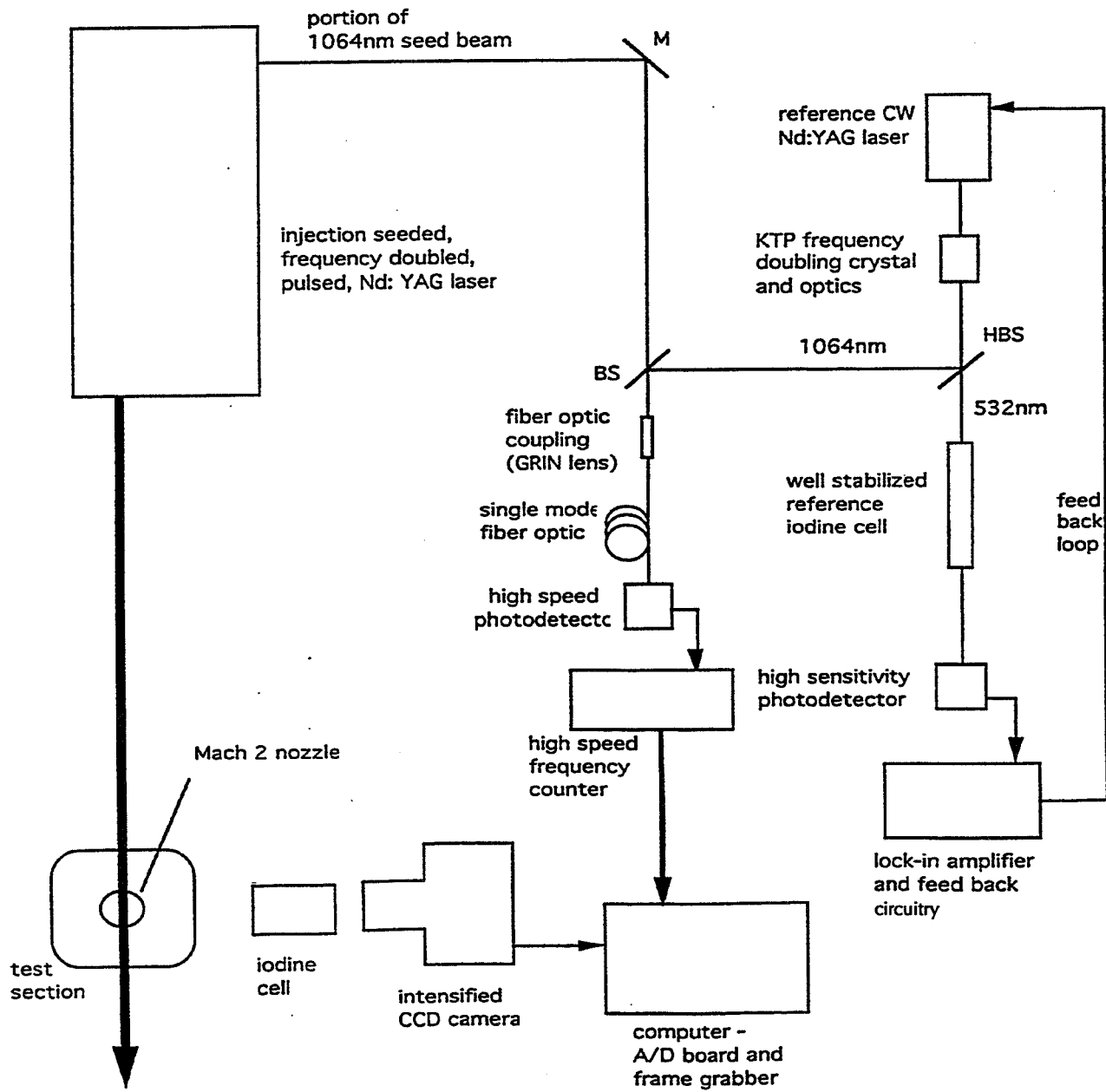

Cell Transmission of Pulsed Laser: Data and Fit

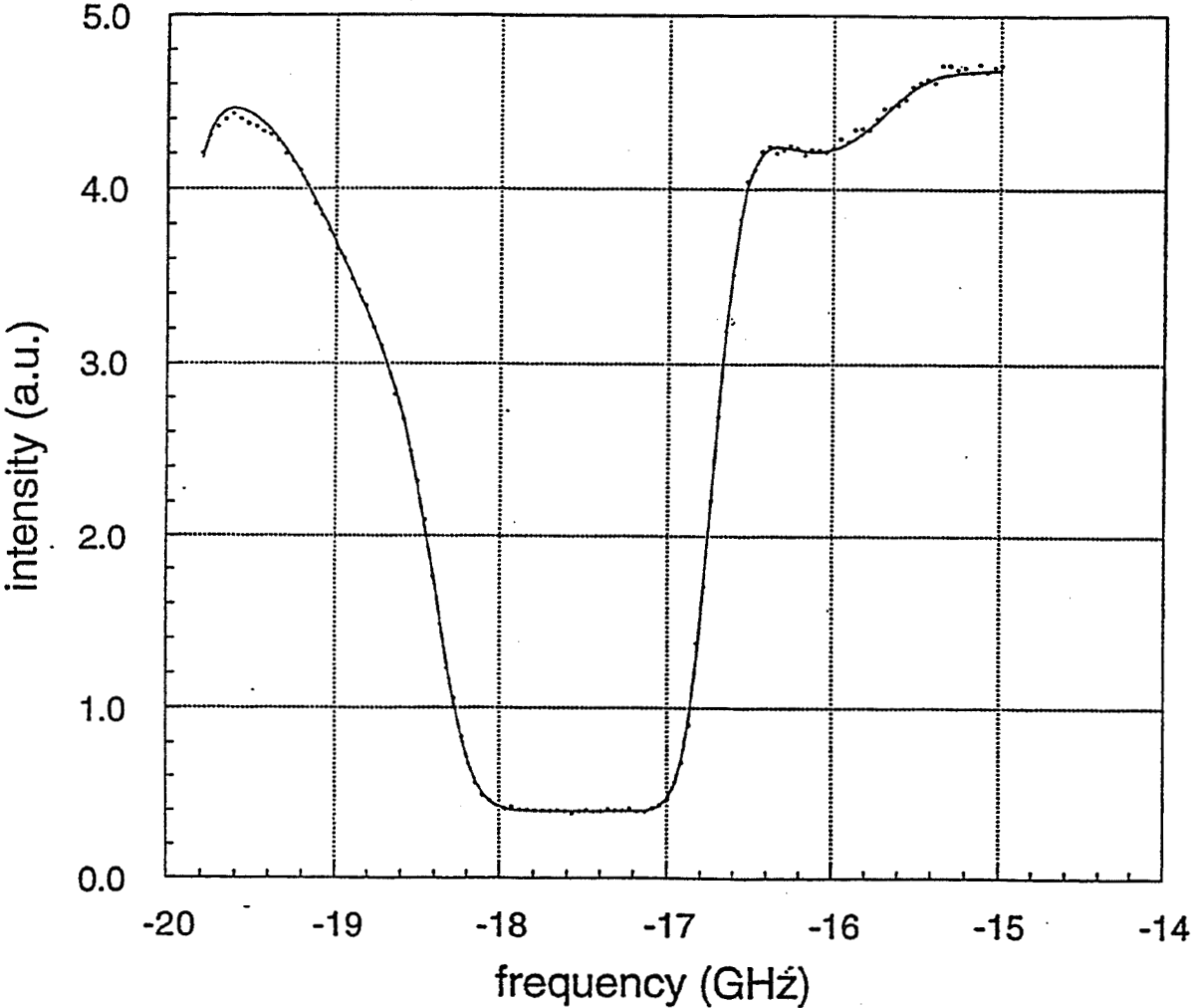

Fit to Data

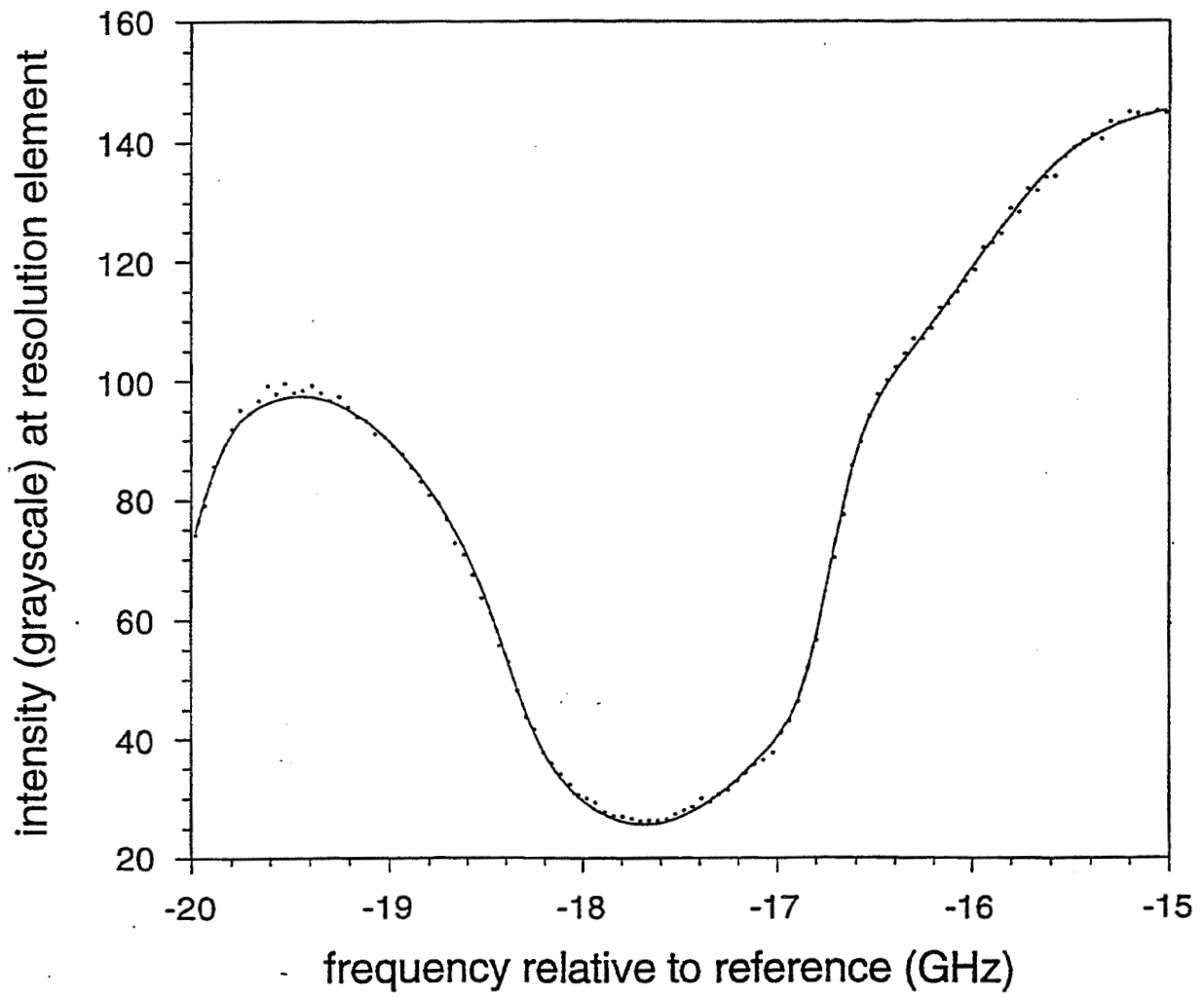

MACH 2 FREE JET VELOCITY IN DIRECTION OF SENSITIVITY

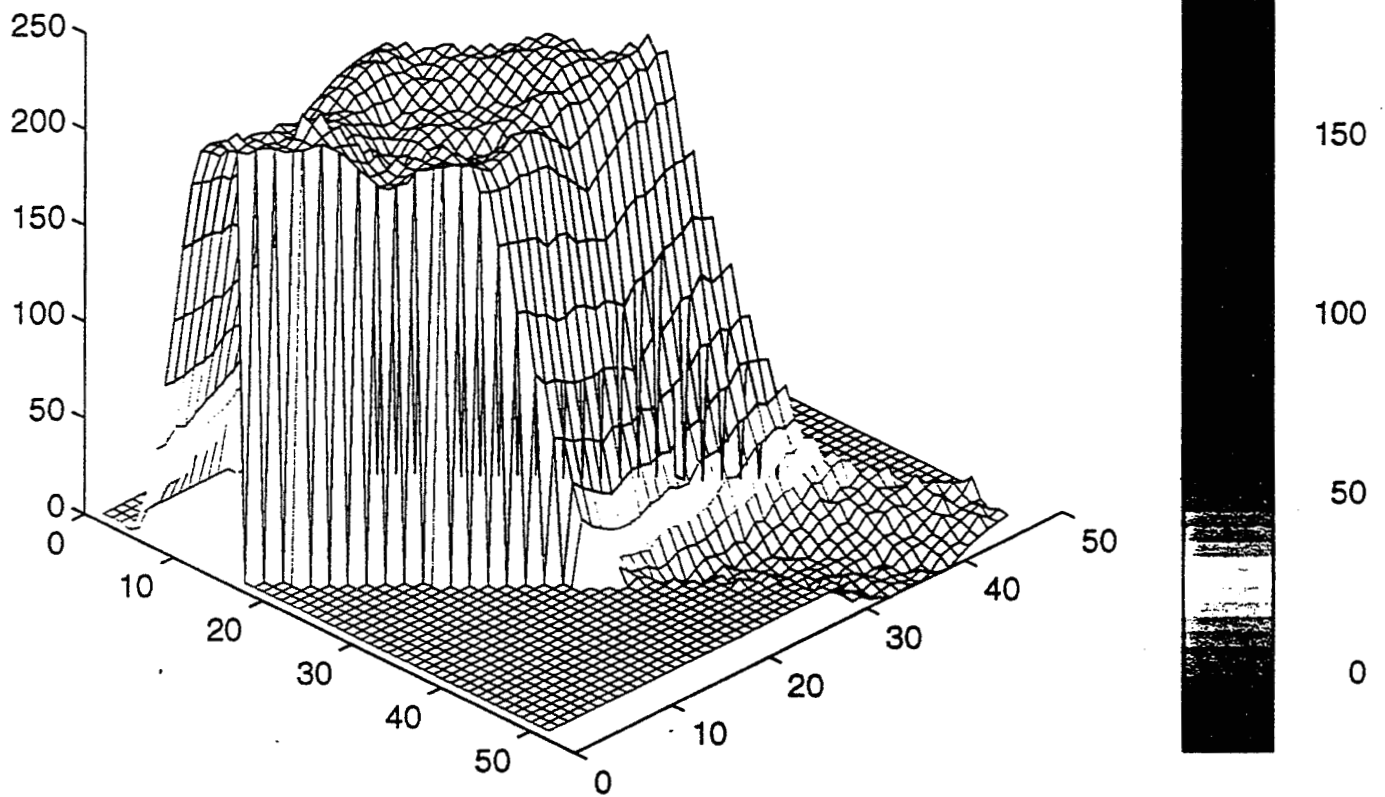

MACH 2 FREE JET STATIC TEMPERATURE

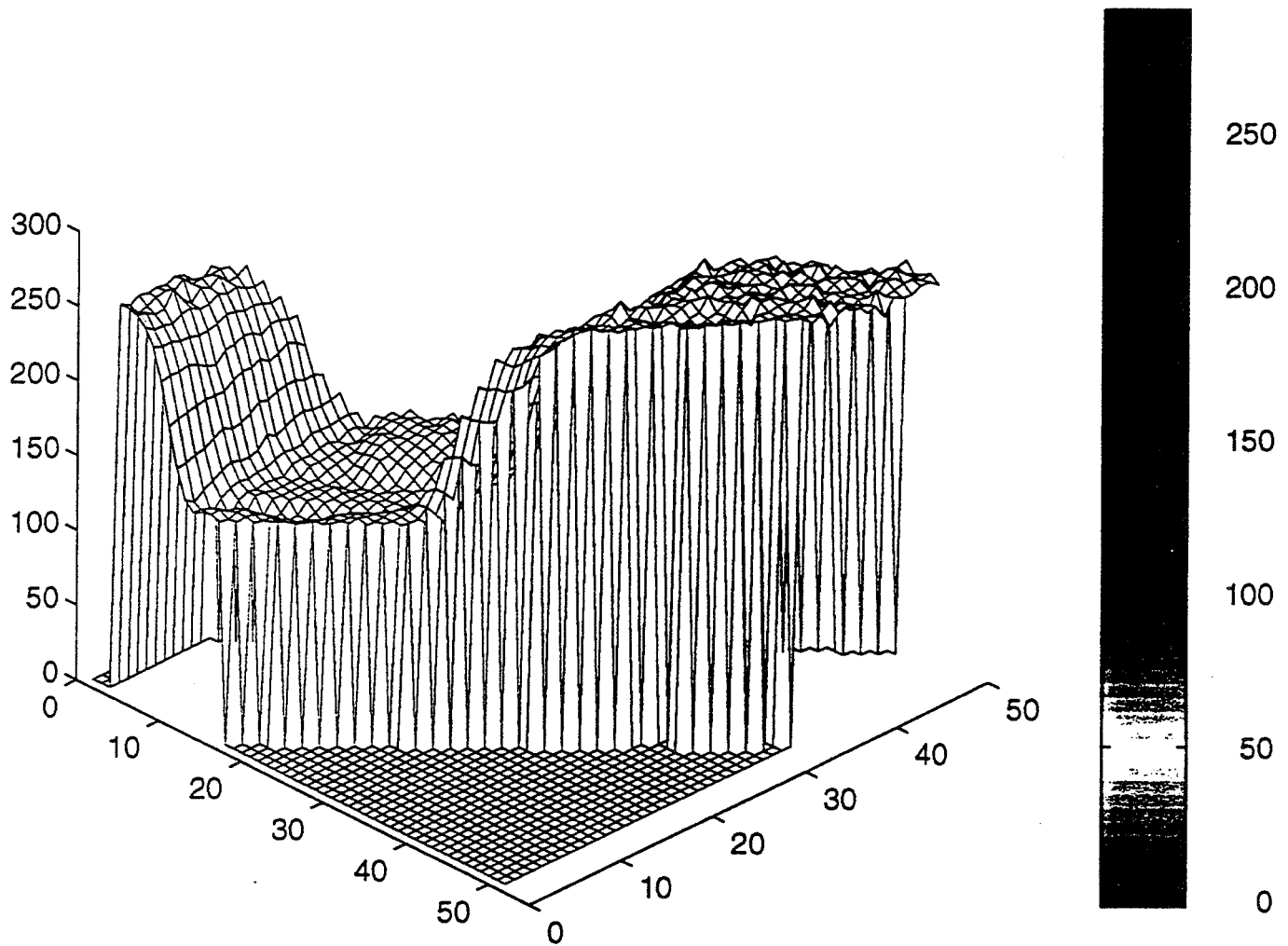

MACH 2 FREE JET STATIC PRESSURE

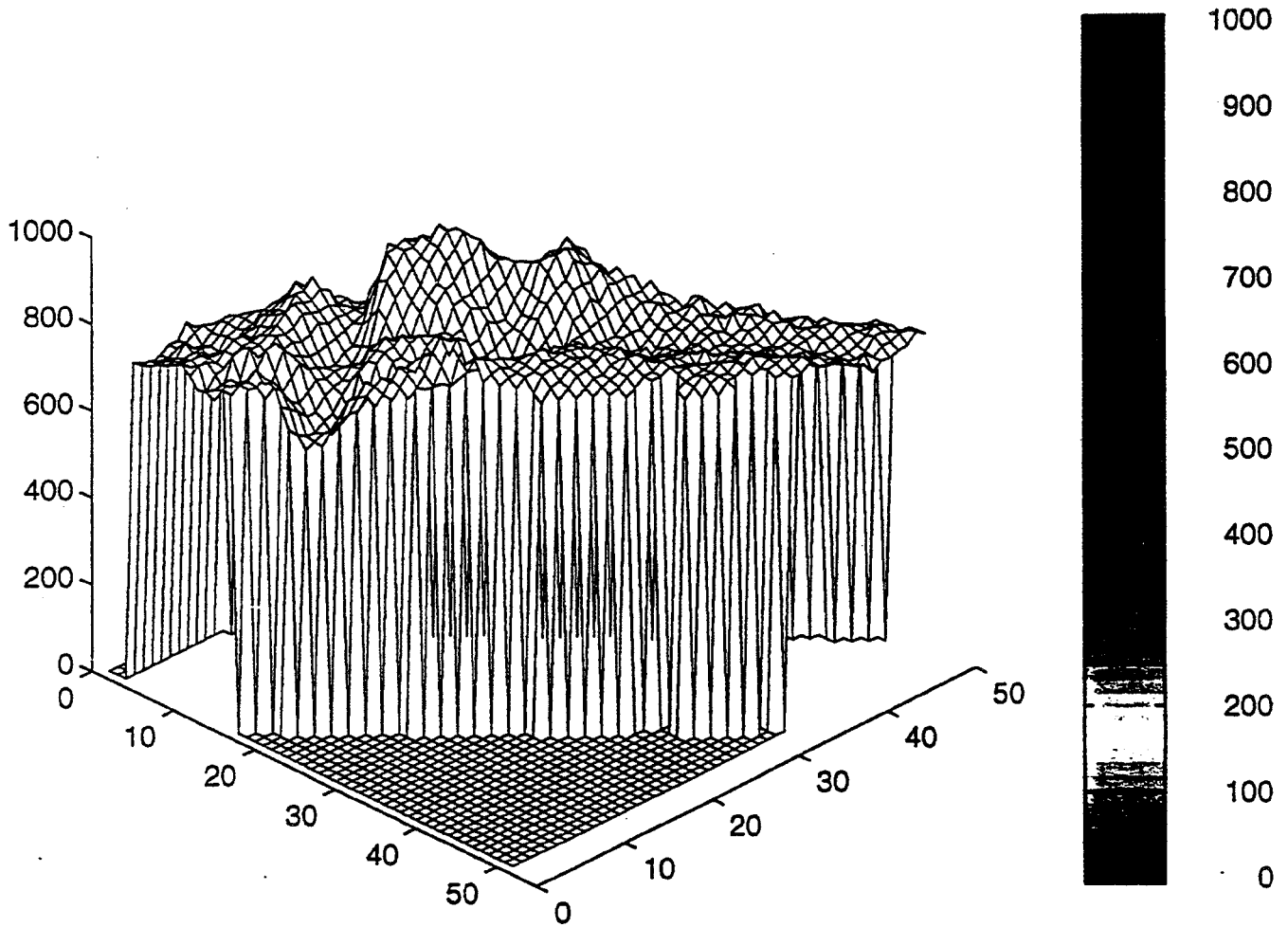

RESEARCH CHALLENGES

- High precision and high accuracy measurements.
- High resolution.
- Instantaneous measurements.
- Volumetric images.

HIGH RESOLUTION

- Move to the ultraviolet $\left[\frac{\partial \sigma}{\partial \Omega} \approx \omega^4 \right]$.
- Improve the light collection efficiency.
 - Low F# optics.
 - High quantum efficiency devices.
- Higher Energy Lasers
- Multiple Pass Schemes

VOLUMETRIC MEASUREMENTS

- Multi-color sheets.
- Rapidly scanned laser.
- Multi-pass, time-gated imaging.

INSTANTANEOUS MEASUREMENTS

- Rapid scanned laser.
- Simultaneous multiple filter imaging.
- Simultaneous multi-angle detection.
- Transmitted signal through filter at constant laser wavelength
 - Requires known pressure.
 - Requires known velocity.

A Ti: Sapphire Based Laser Source and Mercury Vapor Filter for UV Filtered Rayleigh Scattering

Noah D. Finkelstein, Walter R. Lempert, and Richard B. Miles
*Department of Mechanical and Aerospace Engineering
Princeton University, Princeton, NJ 08544*

G.A. Rines, A. Finch, R.A. Schwarz
*Schwartz Electro-Optics, Inc.
Concord, MA 01742*

15th Conference on Lasers and Electro-Optics
Baltimore, MD, May 26, 1995

Supported by: AFOSR, and NASA AMES

Tunable Single Frequency UltraViolet Source

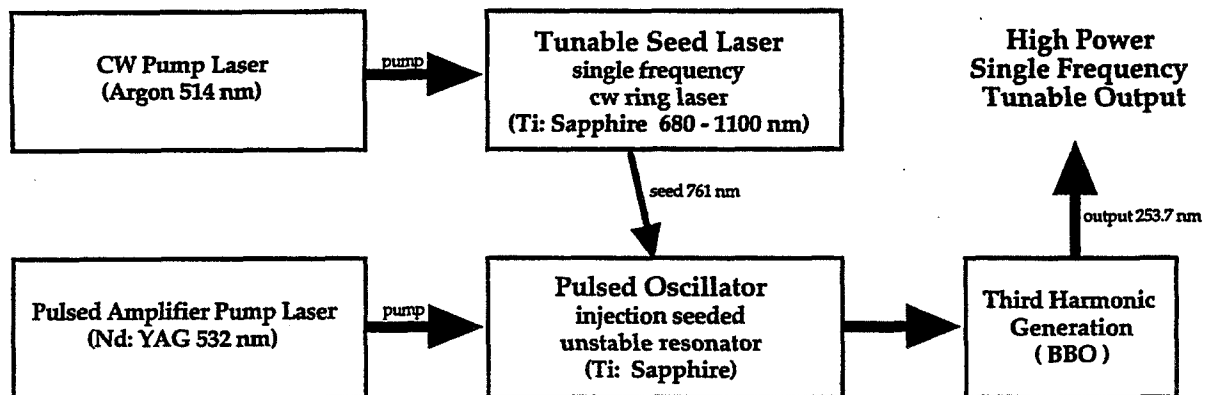

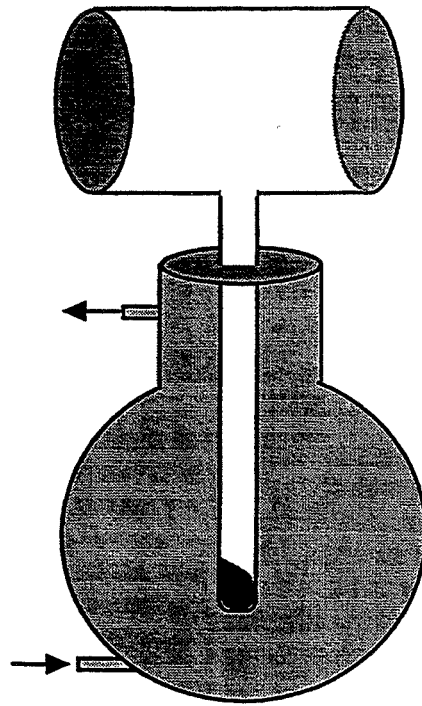

cell length: 5 cm.
 window diameter: 5 cm.
 side arm length: 18 cm.
 bath volume: 0.5 litre
 mercury content: 5 grams
 vacuum: 0.05 torr

Mercury Vapor Cell and Water Bath

Hg Absorption
 23 °C arm / 48 °C cell

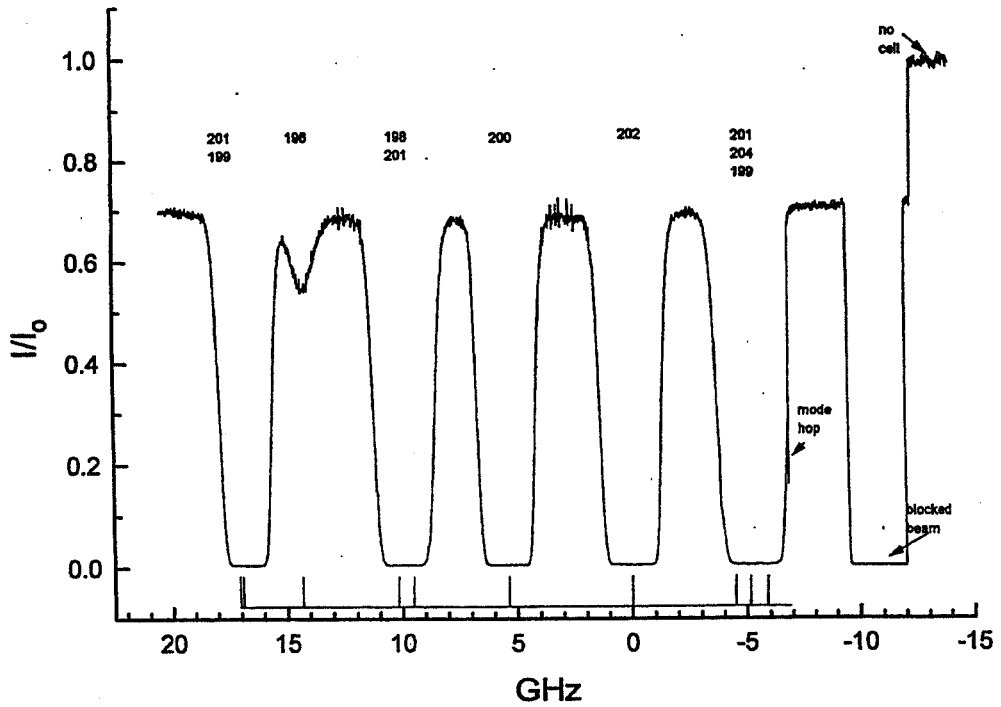

Theory vs. Experiment

Hg 202 close-up

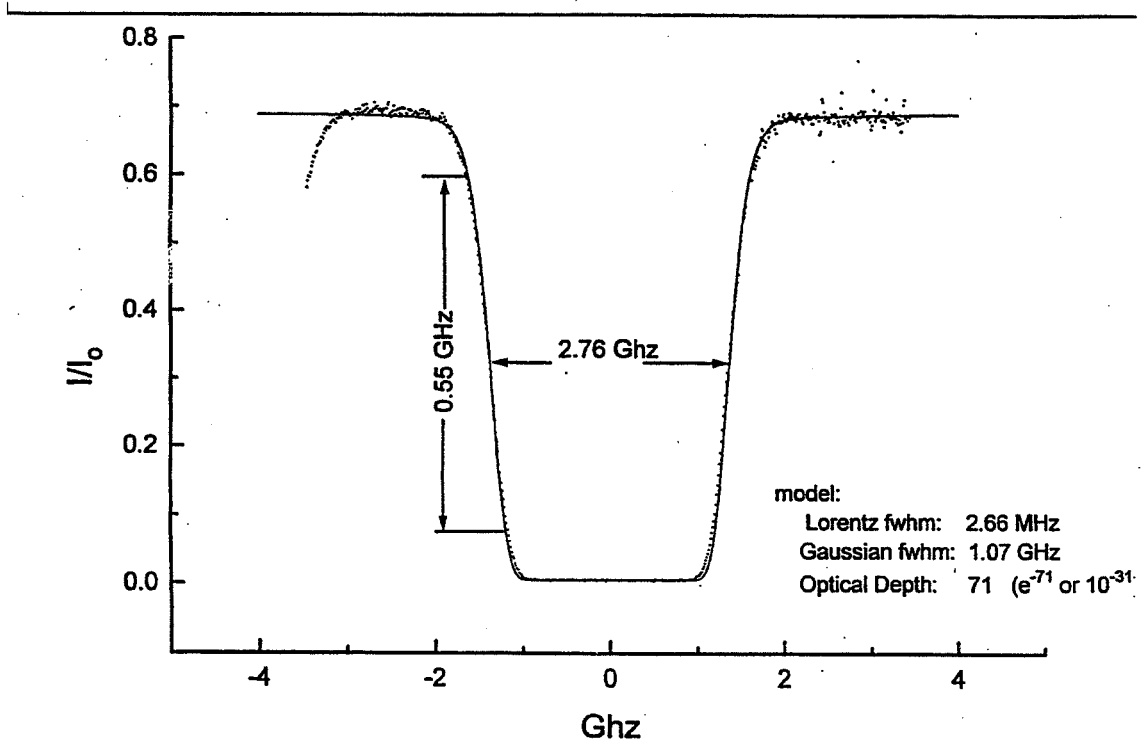

IMAGING A NITROGEN JET: EXPERIMENTAL SET-UP

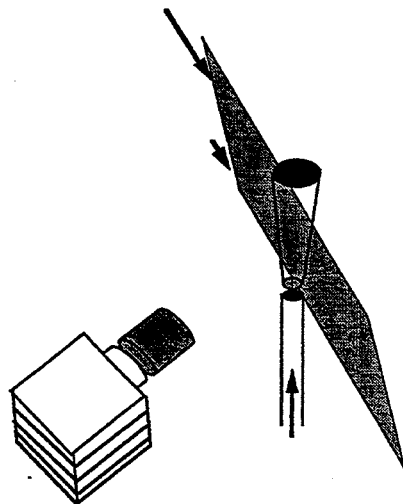

**"FREQUENCY MODULATED-FILTERED
RAYLEIGH SCATTERING:
A NEW VELOCIMETRY TECHNIQUE"**

**Walter R. Lempert, Jay Grinstead,
Noah D. Finkelstein, and Richard B. Miles**

**PRINCETON UNIVERSITY
Department of Mechanical & Aerospace Engineering
Princeton, New Jersey 08544**

and

Moshe Lavid

**M.L. ENERGIA, INC.
Princeton, New Jersey 08542**

PRESENTED TO:

CLEO/QELS 1995

Baltimore, Maryland

May 25, 1995

FM-FRS

BASIC CONCEPT

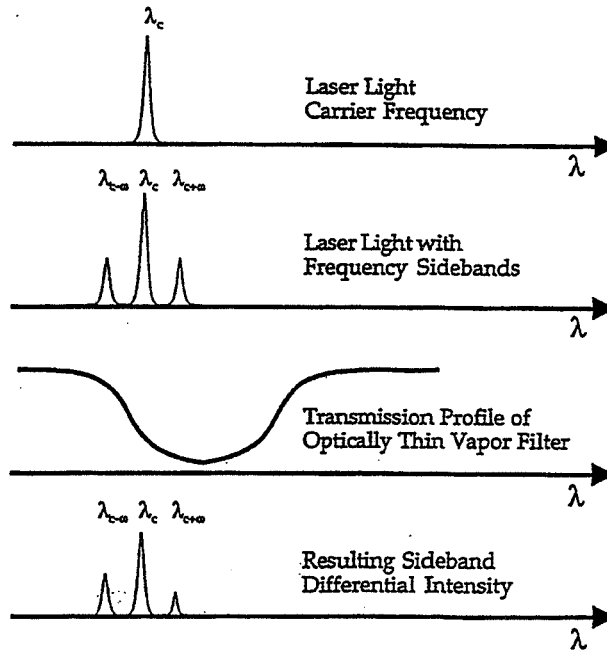

FM-FRS VELOCITY MEASUREMENT

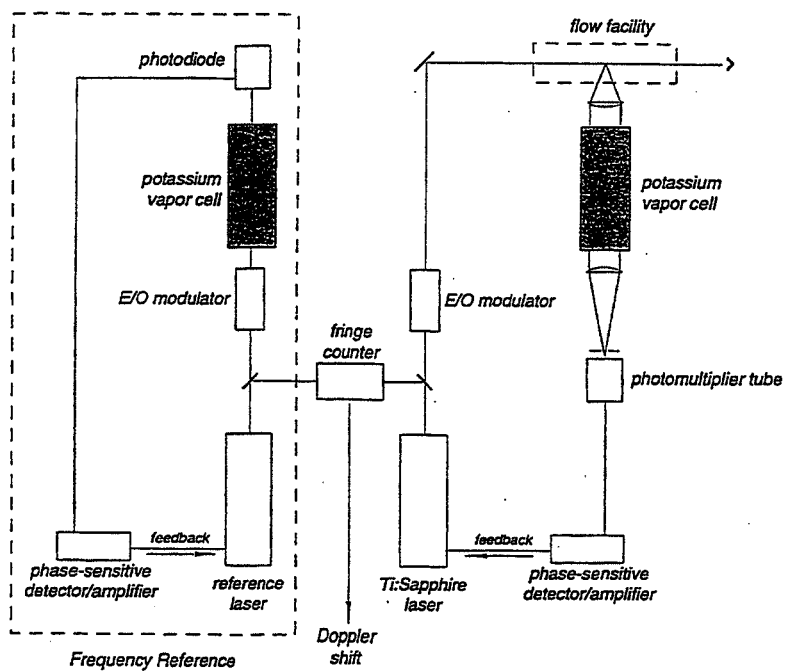

POWER SPECTRUM OF PHASE MODULATED LASER

28.8 dBm Input Power

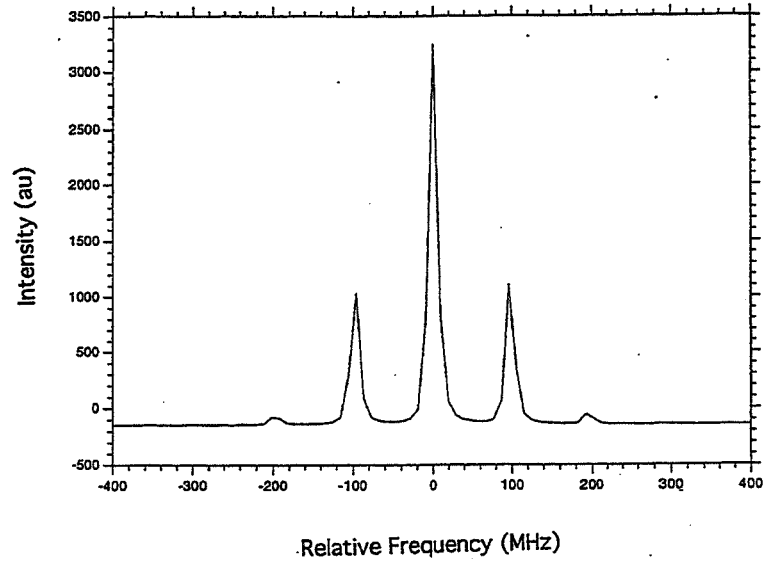

Potassium Vapor Cell and Water Bath

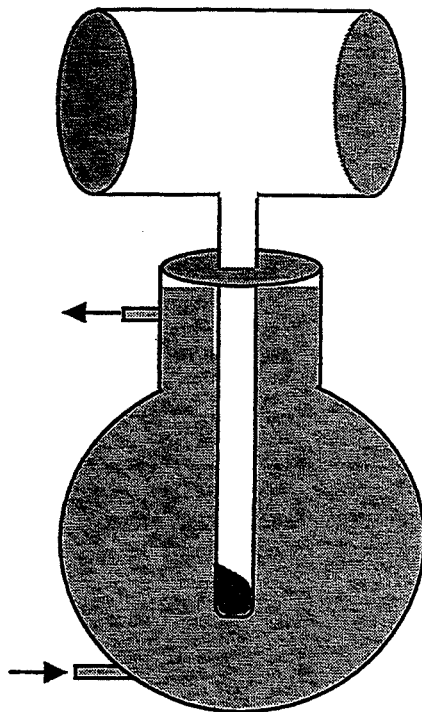

cell length: 15 cm.
window diameter: 5 cm.
side arm length: 15 cm.
bath volume: 0.5 litre
temp: 310 K
vapor pressure: $\sim 1 \mu$ torr

1f FM Spectrum of Scattering by Room Air

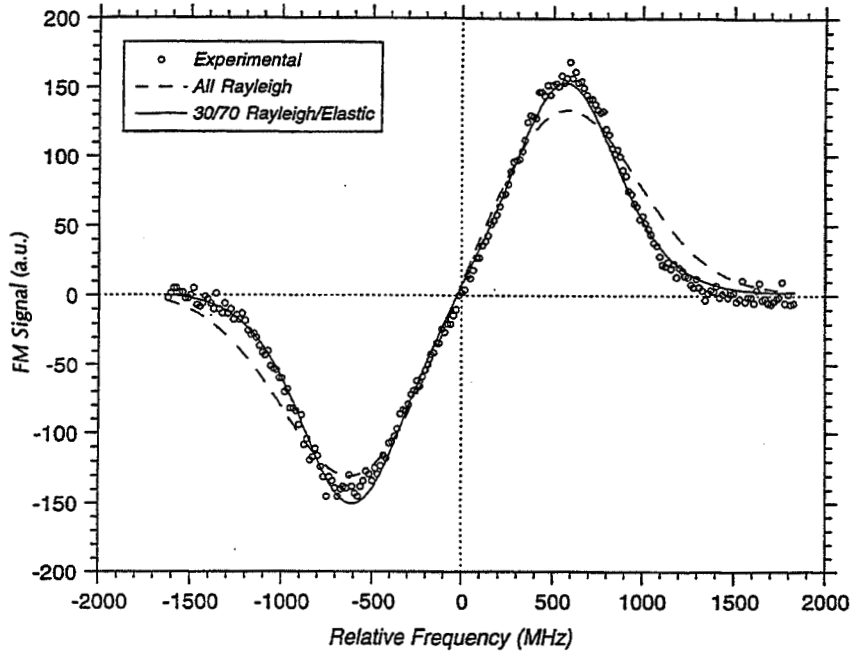

FILTERED RAYLEIGH AND FM-FRS SPECTRUM OF ROOM AIR

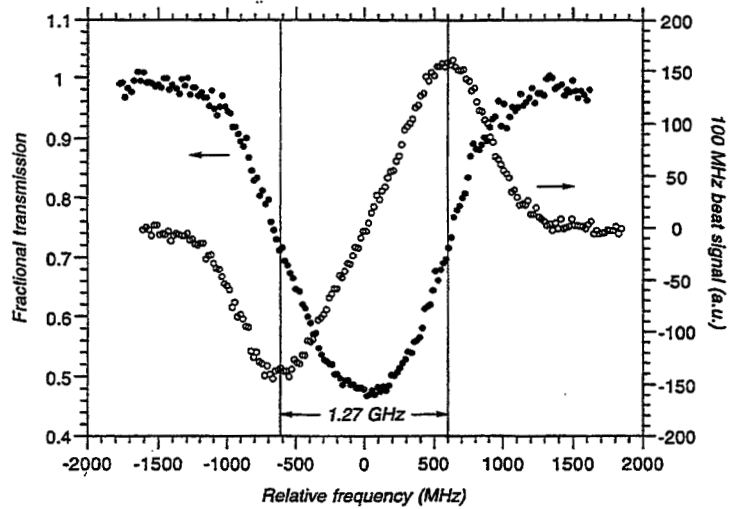

CONCLUSIONS

- Obtained 1st derivative scattering spectra.
- Estimated velocity accuracy order m's/sec.
- Velocity measurement independent of flow composition.
- 2nd derivative nulling provides immunity from stray elastic scattering (particularly for high velocity).

Acknowledgments

U.S. Air Force Arnold Engineering Development Center
M.L. Energia, Inc.

- Rayleigh imaging is already impacting high-speed fluid mechanics.
- Filters block background for better quality images—especially near walls.
- Velocity and temperature imaging is feasible.
- New advances for stronger signals, instantaneous images, and volumetric measurements are currently being explored.
- Rayleigh scattering has the potential of being a practical diagnostic tool for high-speed flows.

FUNDAMENTALS OF RAYLEIGH-BRILLOUIN SCATTERING

James Lock
Cleveland State University
Cleveland, Ohio

- Light is scattered by molecules

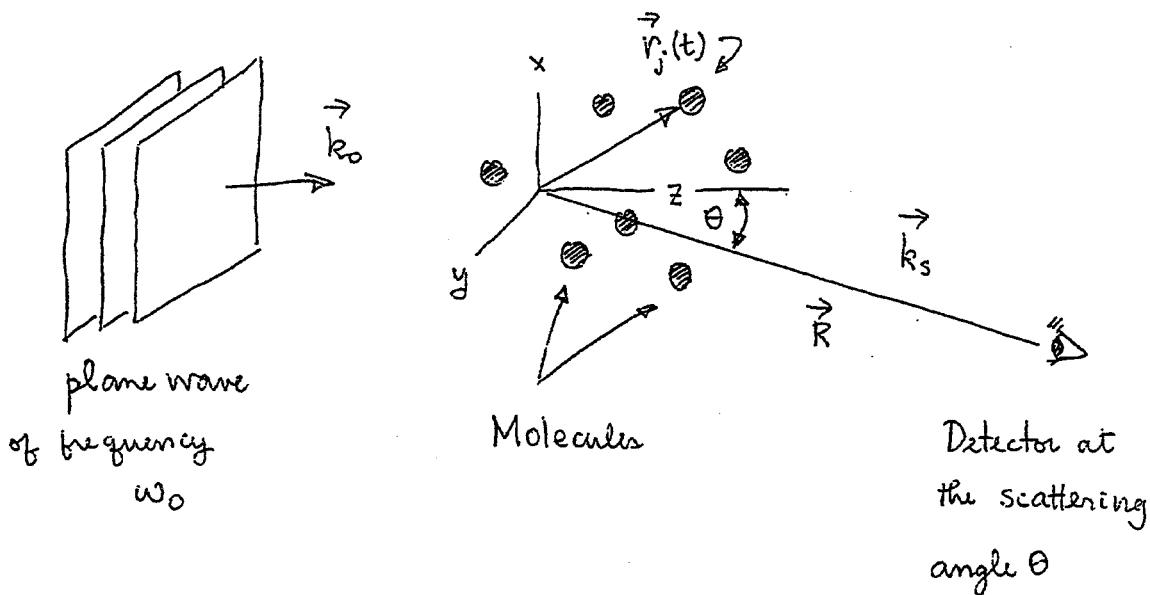

$$\vec{E}_{total}(\theta, t) = \sum_{j=1}^N \frac{\vec{E}_{each}(\theta)}{R} e^{i\vec{k}_0 \cdot \vec{r}_j - i\omega_0 t'_j}$$

$$t'_j = t - \frac{|\vec{R} - \vec{r}_j|}{c}$$

phase factor dependent
on the position of the
molecule

$$\vec{E}_{total}(\theta, t) = \frac{\vec{E}_{each}(\theta)}{R} e^{i\vec{k}_0 \cdot \vec{R} - i\omega_0 t} \sum_{j=1}^N e^{-i(\vec{k}_s - \vec{k}_0) \cdot \vec{r}_j(t)}$$

- Scattering momentum transfer $\vec{K} = \vec{k}_s - \vec{k}_0$ $|\vec{K}| = 2k_0 \sin \frac{\theta}{2}$

- Focus on the spectral characteristics of the scattered light, i.e. how much of each frequency you have.

$$\vec{E}(\omega) = \int_{-\infty}^{\infty} dt \vec{E}_{\text{total}}(t) e^{i\omega t}$$

↖ Fourier transform

$$I(\omega) = \frac{1}{2\mu_0 c T} |\vec{E}(\omega)|^2$$

$$= \frac{1}{2\mu_0 c T} \int_{-\infty}^{\infty} dt \vec{E}_{\text{total}}^*(t) e^{-i\omega t} \cdot \int_{-\infty}^{\infty} dt' \vec{E}_{\text{total}}(t') e^{i\omega t'} \quad t' = t + \tau$$

$$= \frac{1}{2\mu_0 c} \int_{-\infty}^{\infty} d\tau e^{i\omega \tau} \left[\frac{1}{T} \int_{-\infty}^{\infty} dt \vec{E}_{\text{total}}^*(t) \cdot \vec{E}_{\text{total}}(t + \tau) \right]$$

↑ in equilibrium, all times are equivalent

$$I(\omega) = \frac{I_{\text{each}}}{R^2} \int_{-\infty}^{\infty} dt e^{i(\omega - \omega_0)\tau} \sum_{j,l=1}^N e^{i\vec{k} \cdot [\vec{r}_j(0) - \vec{r}_l(\tau)]}$$

This describes how the Doppler shift in the light scattered by the moving molecules builds up the frequency spectrum.

Work out a few basic examples to get an idea what is going on.

Example #1: Noninteracting molecules all moving with the

velocity \vec{v}_0 .

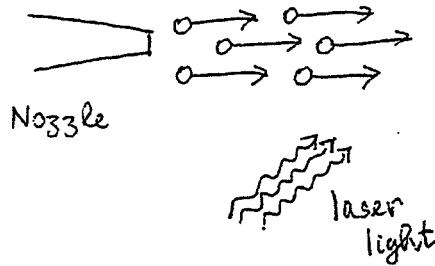

Light scatters in an identical way from each molecule.

$$\vec{r}_j(\tau) = \vec{r}_j(0) + \vec{v}_0 \tau$$

$$I(\omega) = \frac{I_{\text{each}}}{R^2} \underbrace{\int_{-\infty}^{\infty} dt e^{i(\omega - \omega_0 - \vec{k} \cdot \vec{v}_0) \tau}}_{\text{Frequency dependence}} \underbrace{\sum_{j \neq l} e^{i\vec{k} \cdot [\vec{r}_j(0) - \vec{r}_l(0)]}}_{\text{angular variation in intensity}}$$

Frequency dependence

$$\delta(\omega - \omega_0 - \vec{k} \cdot \vec{v}_0)$$

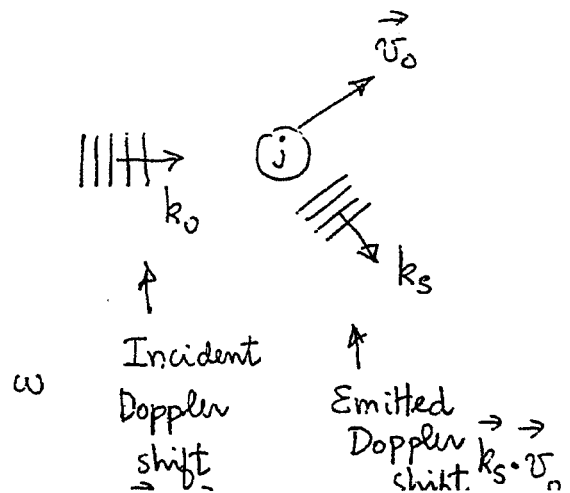
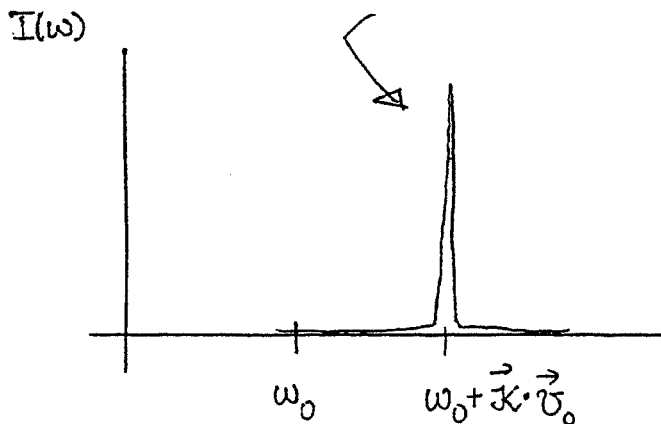

Example #2: Molecules leaving the nozzle have a velocity distribution centered on \vec{v}_0 . Distribution has width W .

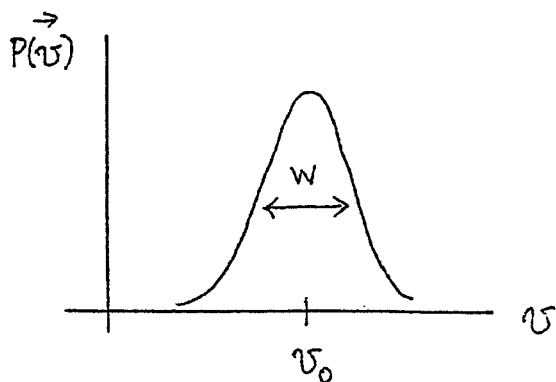

$$P(\vec{v}) = \text{probability that a molecule has the velocity } \vec{v}$$

$$= \frac{1}{\pi^{3/2} W^3} e^{-|\vec{v} - \vec{v}_0|^2 / W^2}$$

$$I(\omega) = \frac{N I_{\text{each}}}{R^2} \int_{-\infty}^{\infty} d\tau e^{i(\omega - \omega_0)\tau} \int d^3v P(\vec{v}) e^{-i\vec{k} \cdot \vec{v} \tau}$$

$$= \frac{N I_{\text{each}}}{R^2} \frac{2\sqrt{\pi}}{Wk} e^{-(\omega - \omega_0 - \vec{v}_0 \cdot \vec{k}) / W^2 k^2}$$

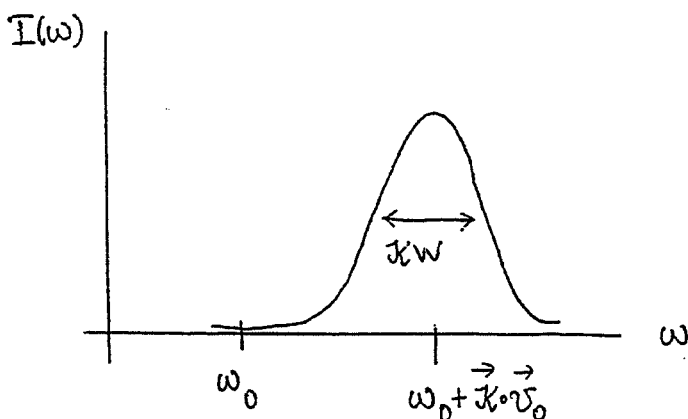

The many different molecule velocities produce many different Doppler shifts in frequency.

Example #3: A box of noninteracting gas molecules

at the temperature T .

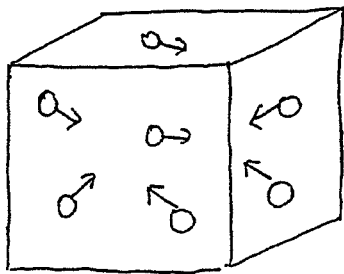

$$\vec{r}_j(\tau) = \vec{r}_j(0) + \vec{v}\tau$$

$$P(\vec{v}) = \left(\frac{m}{2\pi k_B T}\right)^{3/2} e^{-m\vec{v}^2/2k_B T}$$

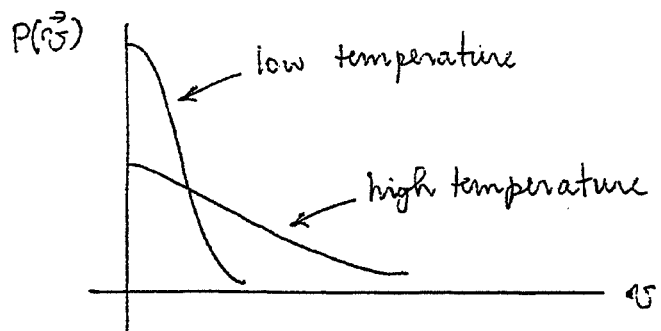

$$I(\omega) = \frac{N I_{\text{each}}}{R^2} \int_{-\infty}^{\infty} d\tau e^{i(\omega - \omega_0)\tau} \int d^3v P(\vec{v}) e^{-i\vec{k} \cdot \vec{v}\tau}$$

$$= \frac{N I_{\text{each}}}{R^2} \frac{2}{k} \sqrt{\frac{\pi m}{2k_B T}} e^{-\frac{(\omega - \omega_0)^2}{k^2} \left(\frac{m}{2k_B T}\right)}$$

Gaussian lineshape

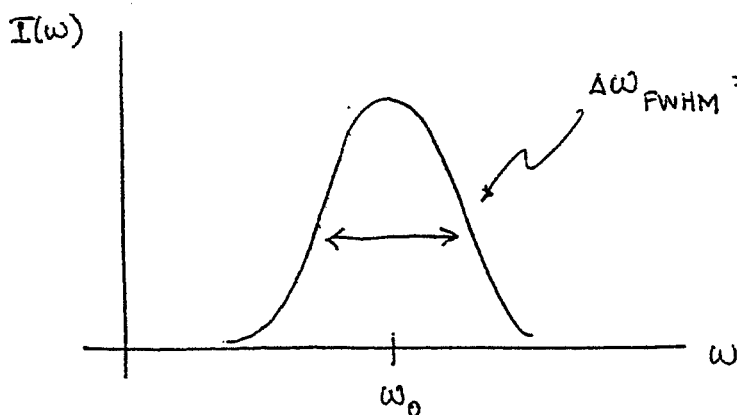

$$\Delta\omega_{\text{FWHM}} = \frac{8\pi}{\lambda} \sqrt{\ln 2} \sqrt{\frac{2k_B T}{m}} \sin \frac{\theta}{2}$$

Again many different molecule velocities produce many different Doppler shifts in frequency.

Example #4: There is a sound wave in the box of gas. This sound wave scatters light.

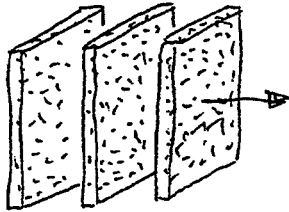

Λ = wavelength of the sound wave.

light.

Ω = frequency of the sound wave.

A = initial amplitude of the sound wave at t_0 .

σ = damping rate of the sound wave.

$$\sum_{j=1}^N \sum_{l=1}^N$$

Sum over molecules

$$\approx \int d^3 r_1 \int d^3 r_2 \rho(\vec{r}_1, t=0) \rho(\vec{r}_2, t=\tau) G(\vec{r}_1, \tau)$$

integral over locations in the box

Gas density

time dependent pair correlation function ≈ 1

if the density is not really big

$$\rho(\vec{r}, t) = \frac{N}{V} + A e^{-(t-t_0)/\sigma} \cos\left(\frac{2\pi}{\Lambda} z - \Omega t\right)$$

$$I(\omega) \approx \frac{I_{\text{each}}}{R^2} \underbrace{\int_{-\infty}^{\infty} dt e^{i(\omega-\omega_0)\tau}}_{\text{temporal integral puts constraints on } \omega} \underbrace{\int d^3 r_1 \rho(\vec{r}_1, 0) \int d^3 r_2 \rho(\vec{r}_2, \tau) e^{i\vec{k} \cdot [\vec{r}_1(0) - \vec{r}_2(\tau)]}}_{\text{spatial integral puts constraints on } \vec{k} \text{ (i.e. on the scattering angle where light will be seen)}}$$

We like to think of this as scattering by a collective motion

of the gas molecules rather than scattering by all of the molecules

Sound wave travels in the z direction so $K_x = K_y = 0$

$$K_z = \frac{2\pi}{\Lambda}$$

$$\vec{k}_s = \vec{k}_0 + \vec{K}_{\text{sound wave}}$$

or

$$\frac{4\pi}{\lambda} \sin \frac{\theta}{2} = \frac{2\pi}{\Lambda}$$

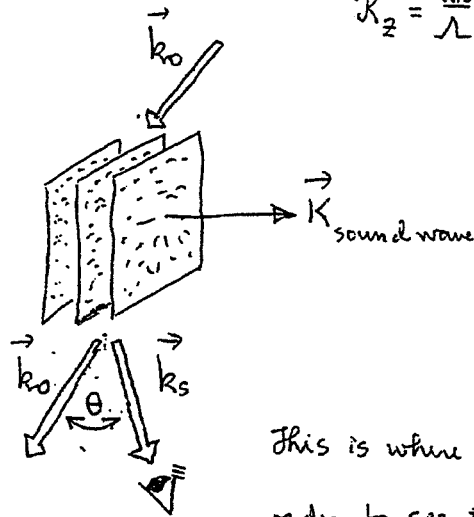

This is where you must look in order to see the scattered light.

The temporal integral says what frequency spectrum you will see if you put your detector in the spatially correct place.

$$I(\omega) = \frac{I_{\text{each}} A^2}{2R^2} \frac{\sigma}{1 + \sigma^2 (\omega - \omega_0 \pm \Omega)^2} \quad \leftarrow \text{Lorentzian lineshape}$$

↑ Intensity is proportional to the intensity of the sound wave

$$\Delta\omega_{\text{FWHM}} = \frac{2}{\sigma}$$

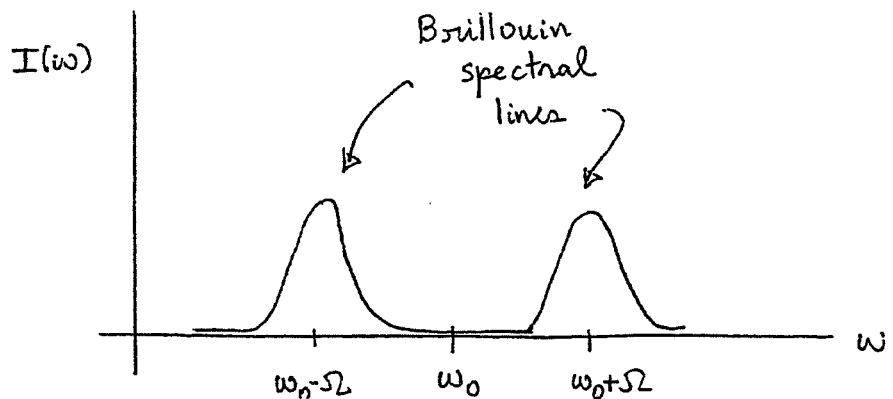

Turn this situation around. In a dense gas there are many thermally created sound waves of different Λ and directions of propagation. They damp out and new ones are thermally created.

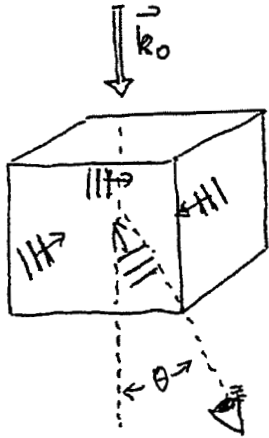

Setting the geometry of the scattering experiment selects one \vec{k} sound wave for study and rejects all the others ($\Lambda = \frac{\lambda}{2} \frac{1}{\sin \theta/2}$). Then measuring the frequency spectrum determines Ω and Γ for that one sound wave.

Other collective motions of the molecules can also scatter light.

Consider the conduction and diffusion of heat.

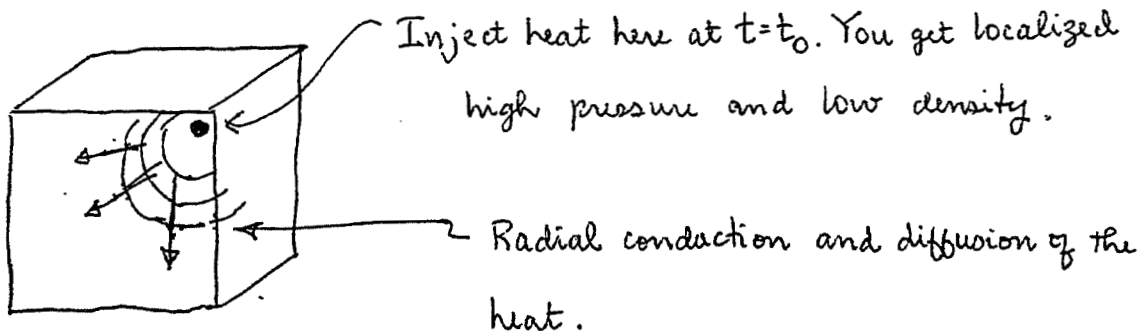

$$\rho(\vec{r}, t) \approx \frac{N}{V} + B e^{-(t-t_0)/\delta}$$

← relaxation of the molecules back to steady state \approx diffusion coefficient.

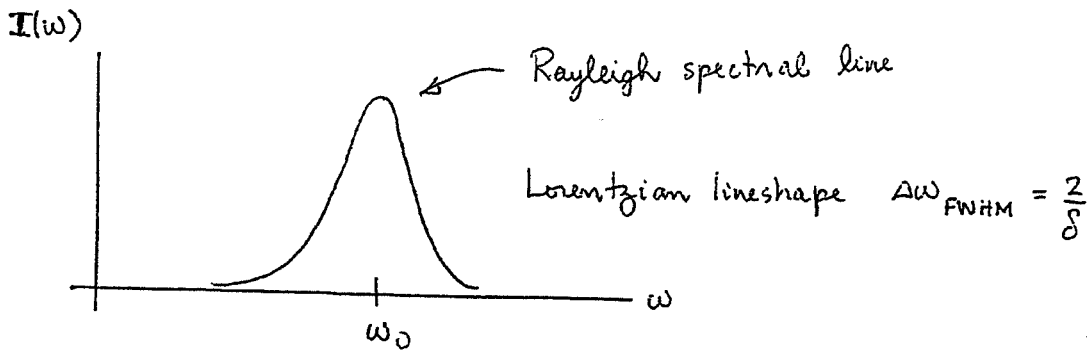

Summary of examples 3 and 4 as the density of gas is varied.

$$\gamma = \frac{1}{\sqrt{2}} \frac{N}{k\eta} \sqrt{mk_B T}$$

N = number density
 η = shear viscosity

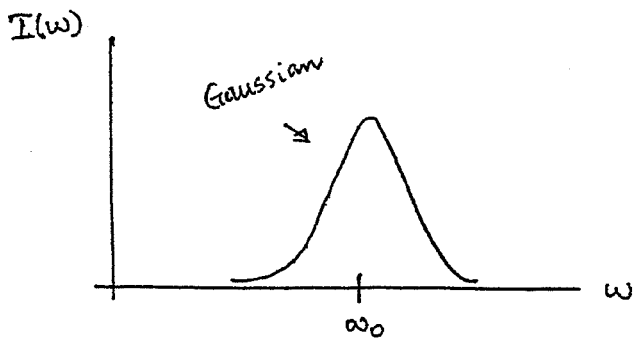

$\gamma \ll 1$. Low density. Almost no molecular collisions. No collective motions can get started. Example 3.

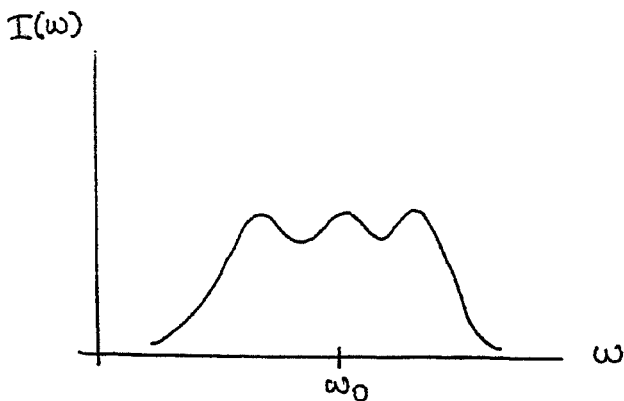

$\gamma \approx 1$. Moderate density. Collective motions begin to form but almost immediately collapse since there are not enough molecular collisions to keep them going.

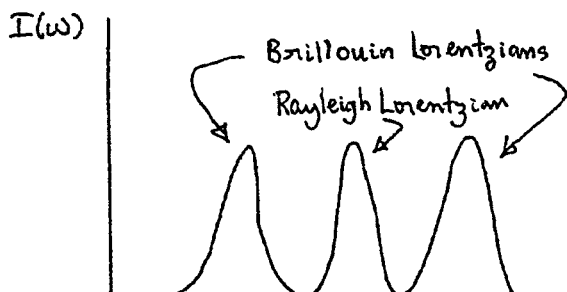

$\gamma \gg 1$. Relatively high density. Slowly damped collective motions are thermally created. Example 4.

Last Thought: Tenti 56 model for the spectrum when $y \approx 1$ for monatomic and diatomic gasses. *Can. J. Phys.* 52, 295-290 (1974)

Claim: The shape of the frequency spectrum depends only on

$$y = \frac{1}{\sqrt{2}} \frac{W}{K\eta} \sqrt{mk_B T}$$

Claim: The shape of the frequency spectrum is written as $I(x)$ where

$$x = \frac{\omega - \omega_0}{K} \sqrt{\frac{m}{2k_B T}}$$

Computer Program Inputs: x, y

Λ = thermal conductivity (tabulated as a function of T)

η = shear viscosity (tabulated as a function of T)

C_{int} = rotational + vibrational specific heat per molecule

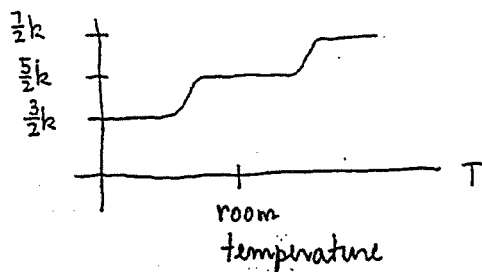

Can. J. Phys. 50, 2158-2173

↓ (1972) appendix B.

η_B = bulk viscosity = damping of sound waves in a gas by converting translational energy to rotational energy.

Related to the sound absorption coefficient.

ABSORPTION FILTER BASED OPTICAL DIAGNOSTICS IN HIGH SPEED FLOWS

Mo Samimy, Gregory Elliott, and Stephen Arnette
Ohio State University
Columbus, Ohio

57-34

79323

209.

232653

Laser light scattered by molecules or particles in a flow contains significant information about properties of the flow. Two major scattering regimes are Mie scattering ($d/\lambda \sim 1$) and Rayleigh scattering ($d/\lambda \ll 1$), where d is the diameter of the scatterer and λ is the wave length of the incident laser light. While Mie scattering is used to obtain only velocity information, Rayleigh scattering can be used to measure both the velocity and the thermodynamic properties of the flow. Over the years, Mie scattering based measurement techniques such as laser Doppler velocimetry (LDV), to measure flow velocity at a single-point, and phase Doppler particle analyzer (PDPA), to measure both velocity and the size of the scatterer, have been developed and are now routinely used in many laboratories. Further, until very recently, Rayleigh scattering based measurement techniques were only used for density or concentration measurements. However, absorption filter based diagnostic techniques, that were introduced by Miles et al. (1990) in Rayleigh scattering regime and by Komine et al (1991) in Mie scattering regime, have started a new era in flow visualizations, simultaneous velocity and thermodynamics measurements, and planar velocity measurements.

For the past several years, we have actively been pursuing absorption filter based flow diagnostics for flow visualizations, planar velocity measurements, and simultaneous velocity and thermodynamic properties measurements. We have used both Mie scattering and Rayleigh scattering for visualizations in mixing layers (Elliott et al., 1992 and 1995), boundary layers (Samimy et al., 1994 and Arnette et al., 1995), and jets (Reeder, 1994 and Reeder et al., 1995).

In a planar velocimetry technique that we call filtered planar velocimetry (FPV), we have modified the optically thick iodine filter profile of Miles et al. (1990) and used it in the pressure-

broaden regime. This technique provides filter tuning to accommodate measurements in a wide range of velocity applications. We initially used this technique for single-component planar velocity measurements (filtered planar velocimetry, FPV) in mixing layers (Elliott, 1993 and Elliott et al., 1994) and very recently used for two-component planar velocity measurements in boundary layers (Arnette, 1995). We are currently working to advance the technique to full three-component planar velocity measurements.

Measuring velocity and thermodynamics properties simultaneously, using absorption filtered based Rayleigh scattering, involves not only the measurement of Doppler shift, but also the spectral profile of the Rayleigh scattering signal. These measurements require scanning of the laser (for mean value measurements only), multiple observation/scattering angles, or several absorption filters. Miles et al. (1992) have used the first scheme, and Shirley and Winter (1993) have shown the feasibility of the second scheme. We have modified and advanced the technique developed by Shirley and Winter. Using multiple observation angles, we have made simultaneous measurements of one-component velocity and thermodynamics properties in a supersonic jet (Elliott and Samimy, 1995 a & b). Presently, we are extending the technique for simultaneous measurements of all three-component of velocity and thermodynamics properties.

ACKNOWLEDGEMENTS

The research has been supported by NASA Lewis Research Center (NAG3-764 & NAG3-1502), AFOSR (F49620-94-1-0074), and DoD(F49620-95-1-0127).

REFERENCES

- Arnette, S.A., "The Effects of Expansion Regions on Supersonic Turbulent Boundary Layer," Ph.D. Dissertation, The Ohio State University, 1995.
- Arnette, S.A., Samimy, M., and Elliott, G.S., "Structure of a Supersonic Boundary Layer after Various Regions of Expansions," *AIAA Journal*, Vol. 33, pp. 430-438, 1995.
- Elliott, G.S., "A Study of Compressible Mixing Layers Using Laser Based Diagnostic Techniques," Ph.D. Dissertation, The Ohio State University, 1993.
- Elliott, G.S., Samimy, M., and Arnette, S.A., "A Study of Compressible Mixing Layers Using Filtered Rayleigh Scattering Based Visualizations," *AIAA Journal*, Vol. 30, No. 10, pp. 2567-2569, 1992.

Elliott, G.S., Samimy, M., and Arnette, S.A., "A Molecular Filtered Based Velocimetry Technique for High Speed Flows," *Journal of Experiments in Fluids*, Vol. 18, pp. 107-118, 1994.

Elliott, G.S., Samimy, M., and Arnette, S.A., "The Characteristics and Evolution of Large Scale Structures in Compressible Mixing Layers," *Physics of Fluids*, Vol. 7, pp. 864-876, 1995.

Elliott, G.S. and Samimy, M., "Simultaneous Measurements of Velocity and Thermodynamics Properties Using a Molecular Filtered Based Technique," 10th Turbulent Shear Flows, Penn State Univ., August, 1995a.

Elliott, G.S. and Samimy, M., "A Rayleigh Scattering Technique for Simultaneous Measurements of Velocity and Thermodynamics Properties," submitted to *AIAA Journal*, May, 1995b.

Komine, H., Brosnan, S.J., Litton, A.B., and Stappaerts, E.A., "Real Time Doppler Global Velocimetry," AIAA-91-0337, 1991.

Miles, R. and Lempert, W., "Flow Diagnostics in Unseeded Air," AIAA-90-0624, 1990.

Miles, R., Forkey, J.N., and Lempert, W., "Filtered Rayleigh Scattering Measurements in Supersonic/Hypersonic Facilities," AIAA-92-3894, 1992.

Reeder, M.F., "An Experimental Study of Mixing Enhancement in Jets with Vortex Generating Tabs," Ph.D. Dissertation, The Ohio State University, 1994.

Reeder, M.F., Samimy, M., and Elliott, G.S., "An Investigation of the Effect of Tabs on Jets Using Advanced Diagnostics," AIAA-95-0672, January, 1995.

Samimy, M., Arnette, S.A., and Elliott, G.S., "Streamwise Structures in a High Reynolds Number Supersonic Boundary Layer," *Physics of Fluids*, Vol. 6, pp. 1081-1083, 1994.

Shirley, J.A. and Winter, M., "Air-Mass Flux Measurements Using Doppler-Shifted Filtered Rayleigh Scattering," AIAA-93-0513, 1993.

OUTLINE OF PRESENTATION

- ABSORPTION FILTER BASED OPTICAL DIAGNOSTICS
 - Filtered Rayleigh Scattering (FRS)
 - Filtered Planar Velocimetry (FPV/PDV/DGV)
 - Filtered Angularly Resolved Rayleigh Scattering (FARRS)
- ABSORPTION FILTER BASED OPTICAL DIAGNOSTICS AT AODL
 - FPV in Compressible Mixing Layers and Supersonic Boundary Layers
 - FARRS in Supersonic Jets
- CURRENT ACTIVITIES AND NEAR FUTURE PLANS

ABSORPTION FILTER BASED OPTICAL DIAGNOSTICS

- FILTERED PLANAR VELOCIMETRY (FPV)
 - The Scattering Medium
 - ▶ Particles($d \sim 50 \text{ nm}$)
 - The Light Source
 - ▶ Injection Seeded Pulsed Nd:YAG Laser @ $\lambda = 532 \text{ nm}$
 - The Molecular Filter
 - ▶ Optically Thick & Pressure Broadened (Tuning Capability for the Velocity Range)
 - The Recording Devices
 - ▶ Scientific Grade ICCD Cameras

ABSORPTION FILTER BASED OPTICAL DIAGNOSTICS

- FILTERED PLANAR VELOCIMETRY (FPV)
 - FPV Results in Compressible Mixing Layers & Comparison with LDV Results
 - Uncertainty Assessment
 - FPV Results in Supersonic Boundary Layers & Comparison with LDV Results

FPV RESULTS IN COMPRESSIBLE MIXING LAYERS
WITH $M_c=0.86$ ($M_1=3$ & $M_2=0.5$)
TWO-CAMERA/ONE-COMPONENT VELOCITY

Laser and Camera Arrangement

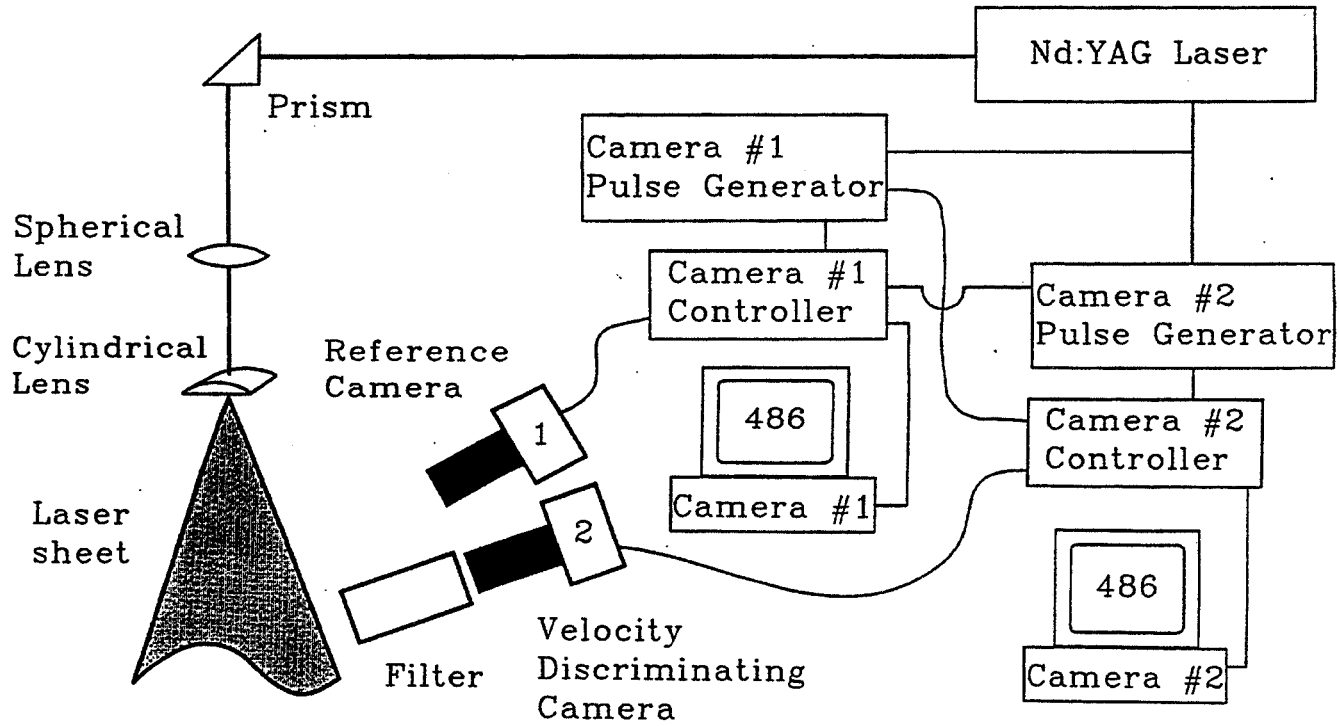

Reference and Velocity Images

$M_c = 0.86$, oblique view

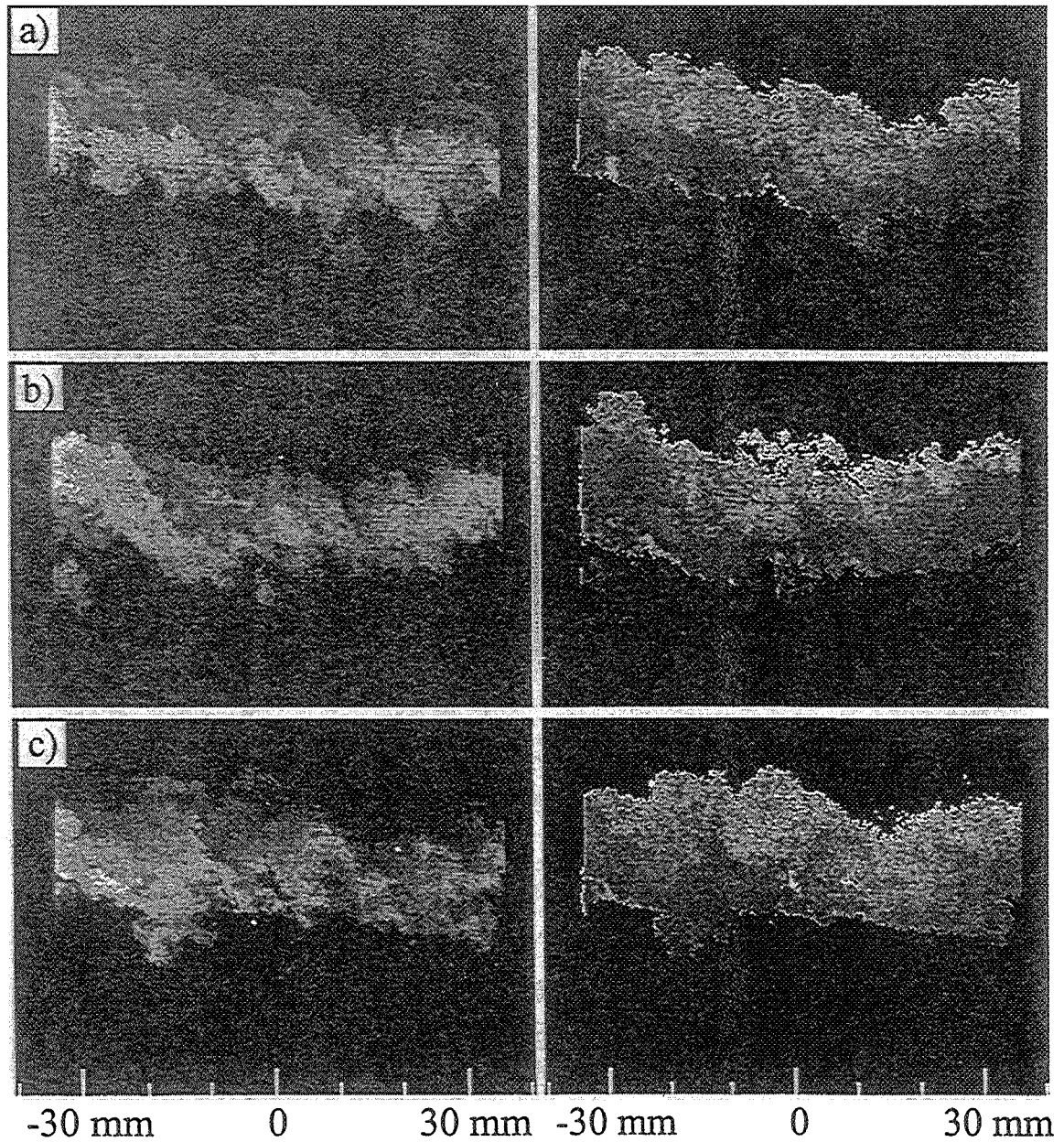

Normalized Streamwise Velocity
 $M_c = 0.86$

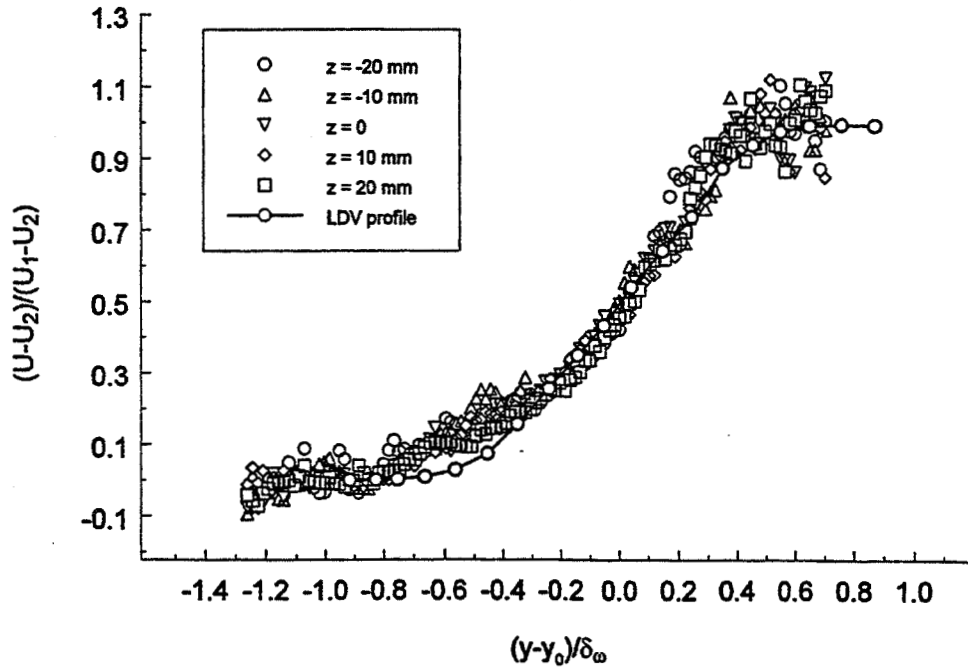

Uncertainty for Filtered Planar Velocimetry

Sources of Error	Maximum % error in Vel.: $M_c = 0.51$	Maximum % error in Vel.: $M_c = 0.86$
Γ	1.17	1.70
I_0	1.20	1.70
ϕ_D	1.74	0
γ_D	0	0.87
θ_D	2.46	0.87
b_A	6.17	5.41

FPV RESULTS IN SUPERSONIC BOUNDARY LAYERS
WITH $M_\infty = 3$
THREE-CAMERA/TWO-COMPONENT VELOCITY

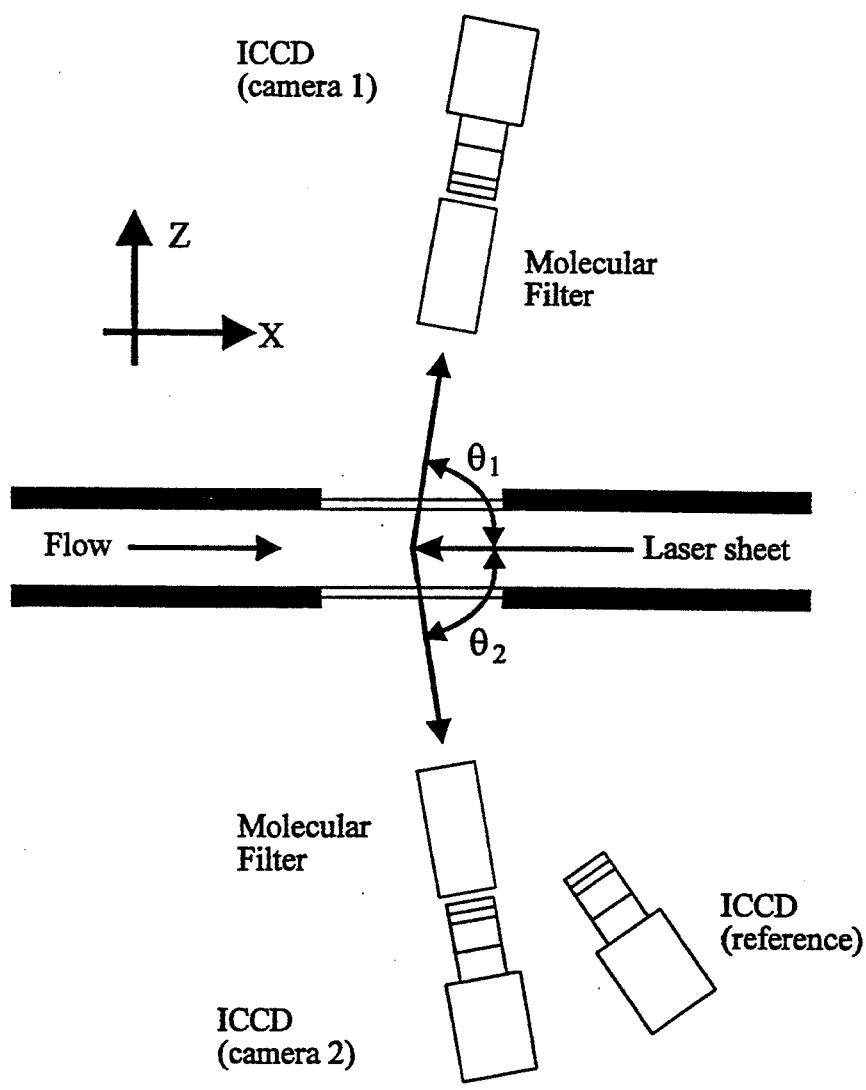

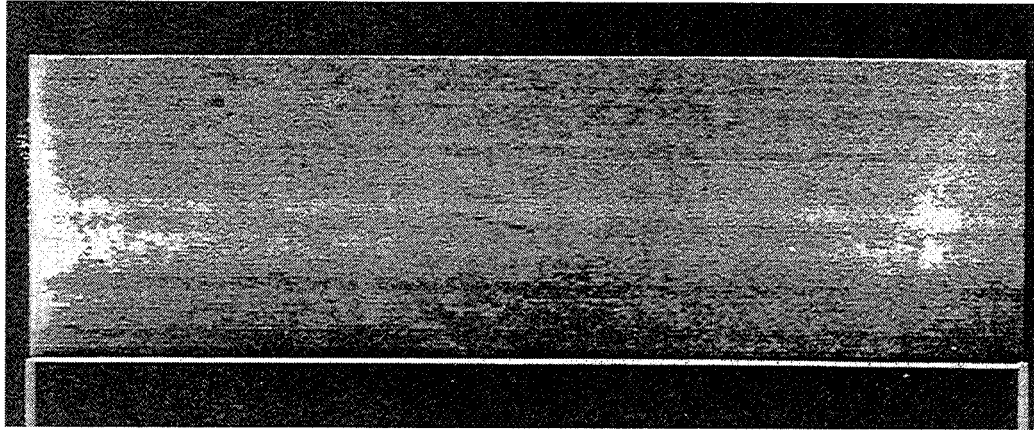

$s/\delta_0 = 0.0$

$s/\delta_0 = 8.8$

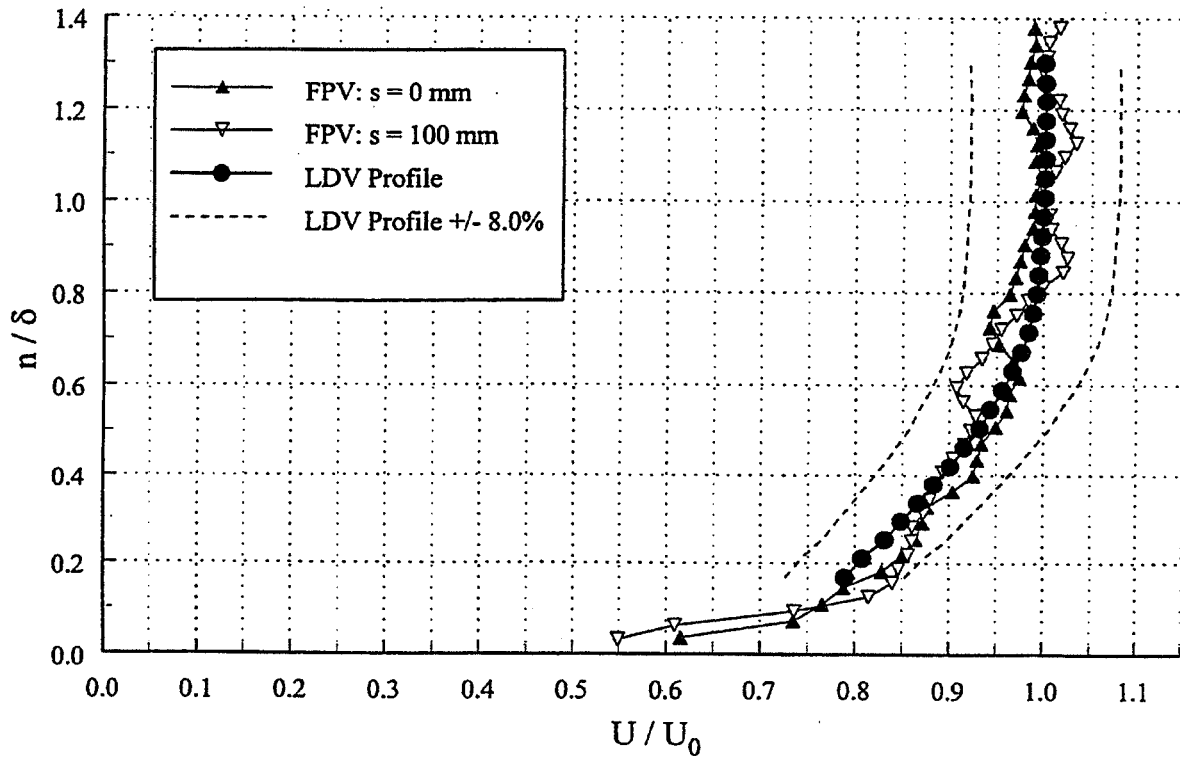

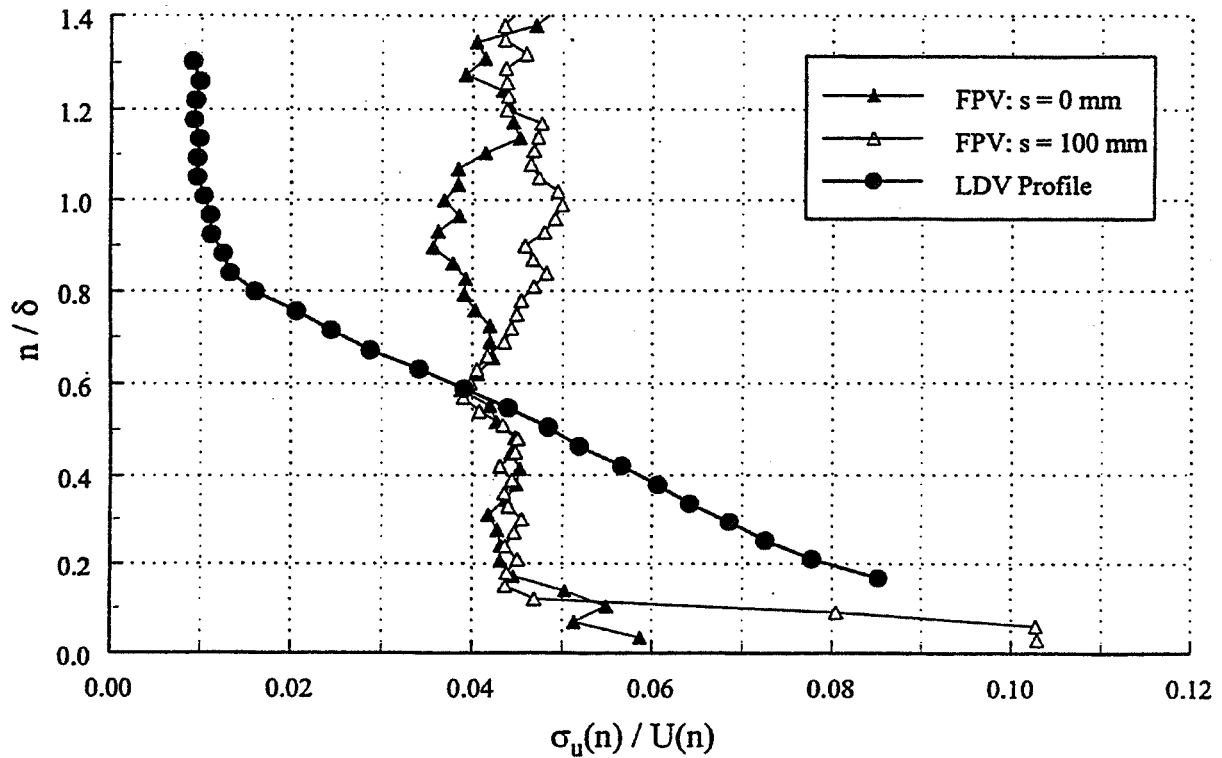

ABSORPTION FILTER BASED OPTICAL DIAGNOSTICS

- FILTERED ANGULARLY RESOLVED RAYLEIGH SCATTERING (FARRS)
 - The Scattering Medium
 - ▶ Air Molecules
 - The Light Source
 - ▶ Injection Seeded Pulsed Nd:YAG Laser @ $\lambda = 532 \text{ nm}$
 - The Molecular Filter
 - ▶ Optically Thick Filter
 - The Recording Devices
 - ▶ Scientific Grade ICCD Cameras

ABSORPTION FILTER BASED OPTICAL DIAGNOSTICS

- FILTERED ANGULARLY RESOLVED RAYLEIGH SCATTERING (FARRS)
 - Experimental Procedure for One-Component Velocity and Thermodynamics Properties Measurements
 - Results in Supersonic Jets & Comparison with Theoretical Results
 - Uncertainty Assessment
 - Current Activities on Three-Component Velocity and Thermodynamics Properties Measurements in Supersonic Jets

Filtered Angularly- Resolved Rayleigh Scattering (FARRS)

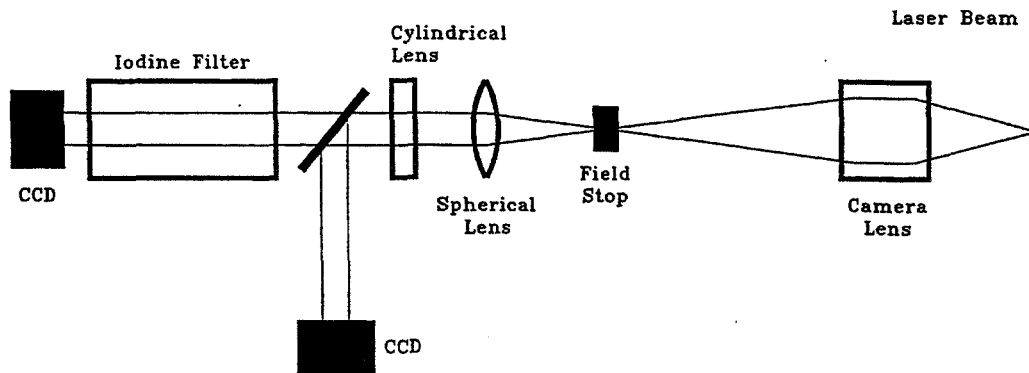

Image Processing

Image without Filter

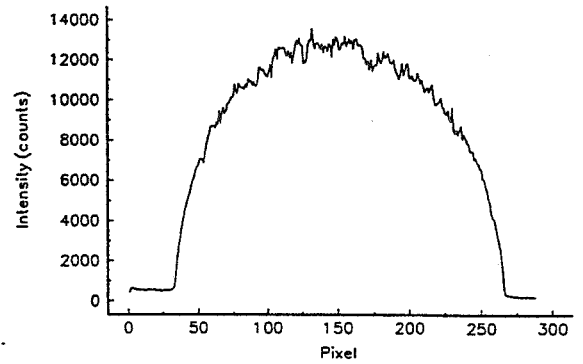
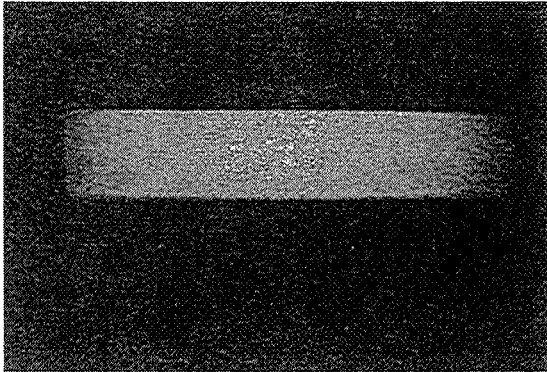
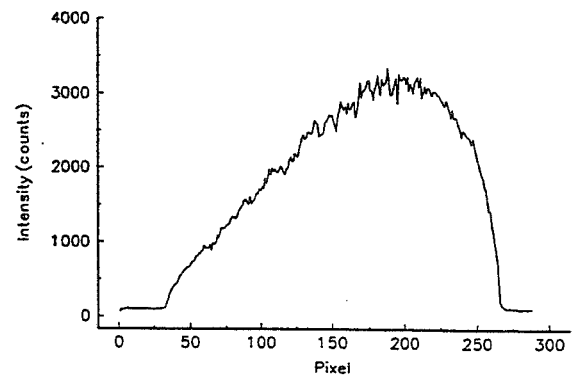
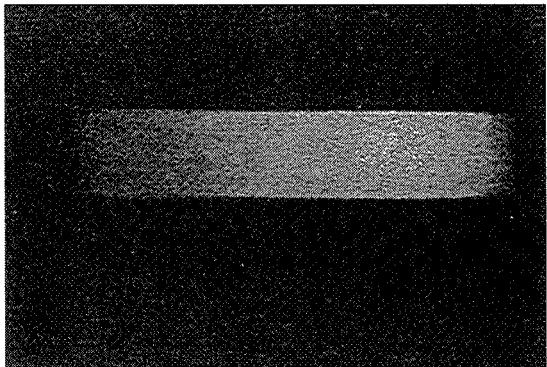
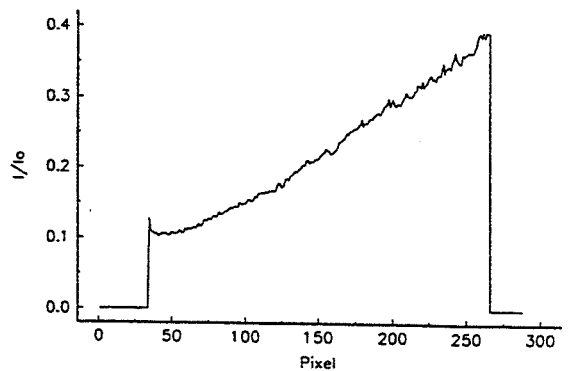
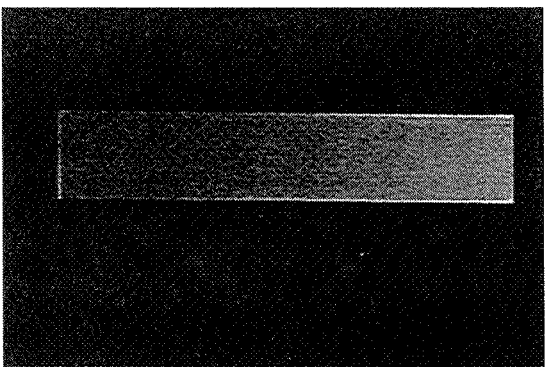
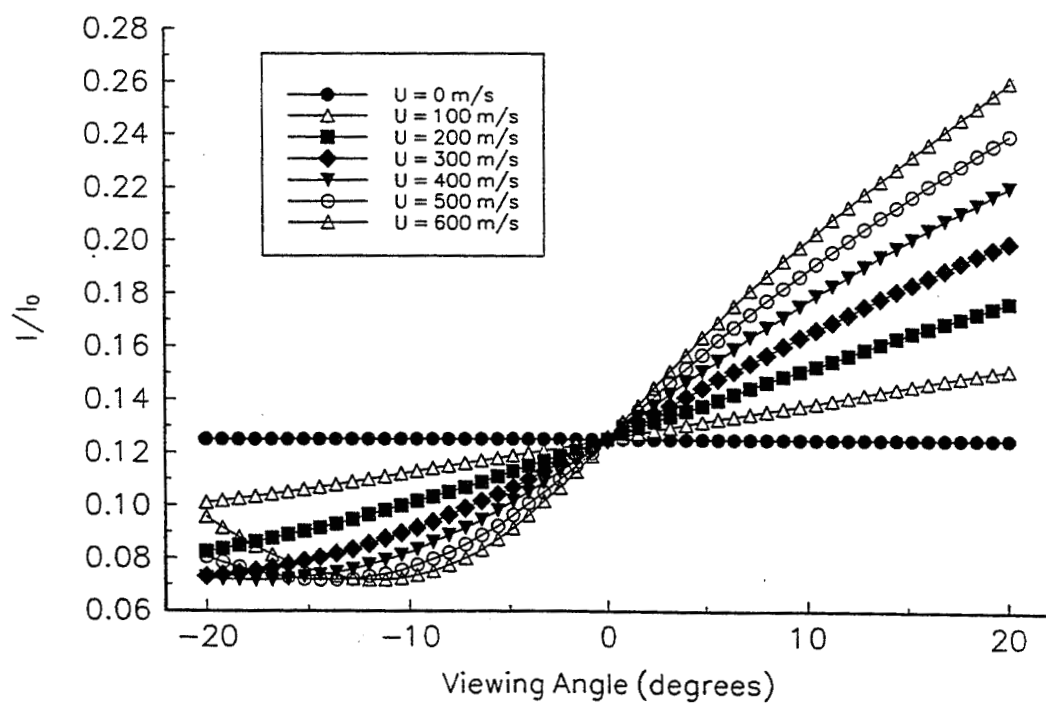
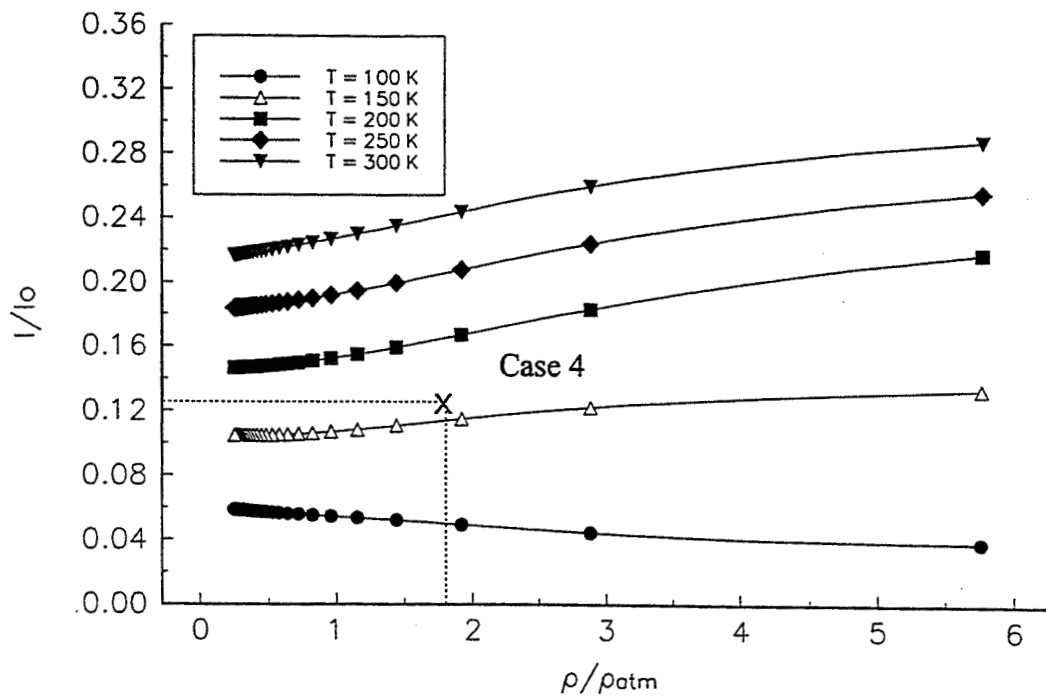

Image with Filter



Normalized Image





RESULTS IN SUPERSONIC JETS & COMPARISON WITH THEORETICAL RESULTS
FULLY EXPANDED $M = 1, 1.5, \& 2$
UNDEREXPANDED $M = 2 @ 2.15 \& 2.3$

Run Conditions for Perfectly Expanded
and Underexpanded Axisymmetric Jet

Case	M_e	T_0 [K]	P_0 [kPa]	U [m/s]
1	0.0	288	0.0	0.0
2	1.00	288	191.8	308.4
3	1.50	288	372.0	420.8
4	2.00	288	793.0	507.1
5	2.15	288	1002.0	507.1
6	2.30	288	1266.9	507.1

Intensity Profiles Perfectly Expanded Jet

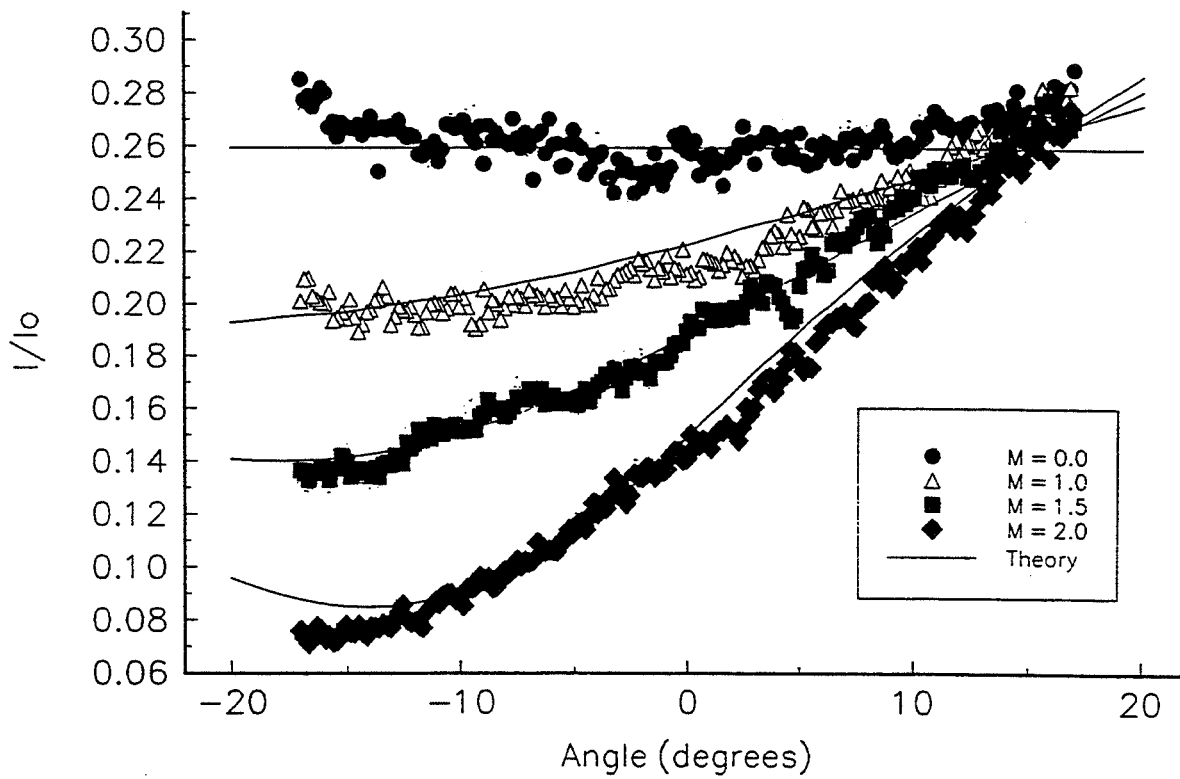

Density

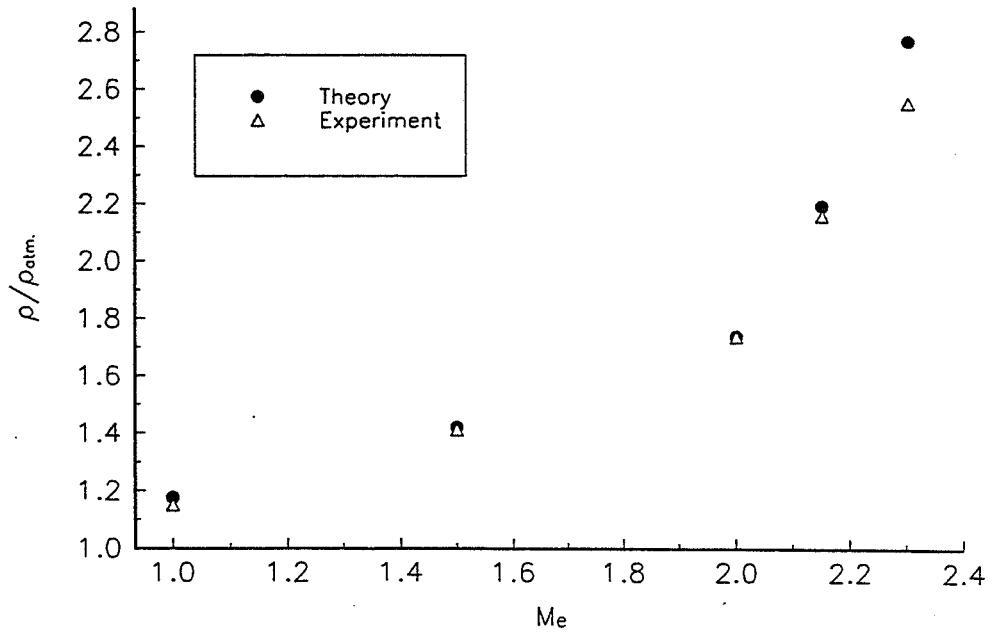

Temperature

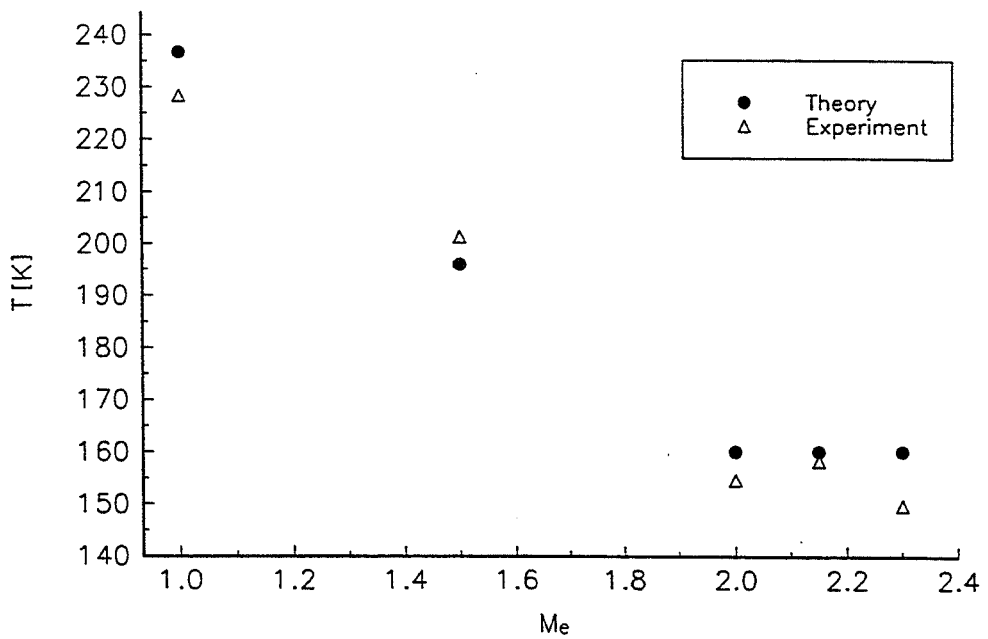

Pressure

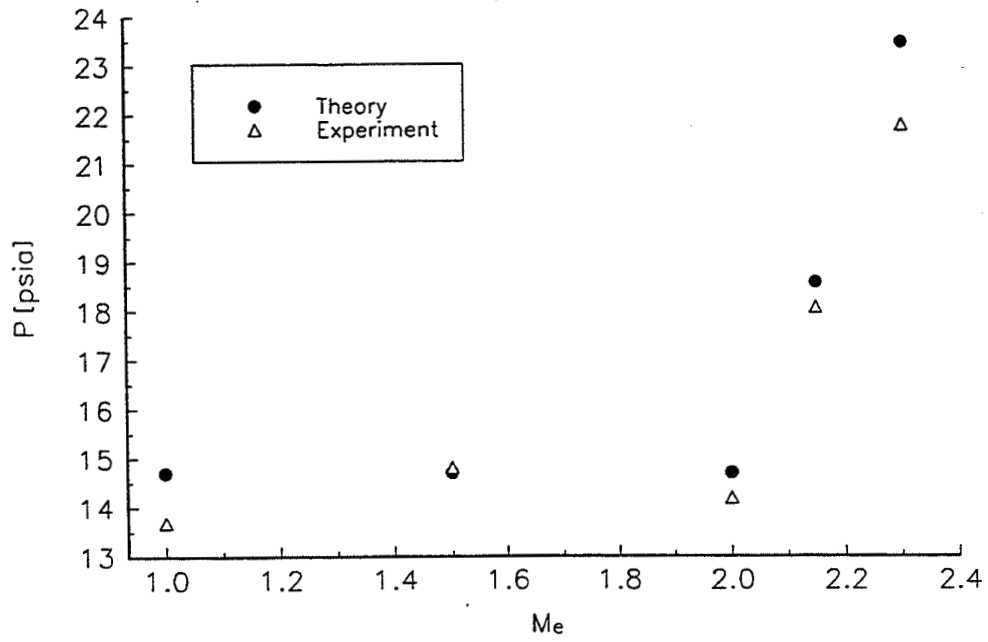

Streamwise Velocity

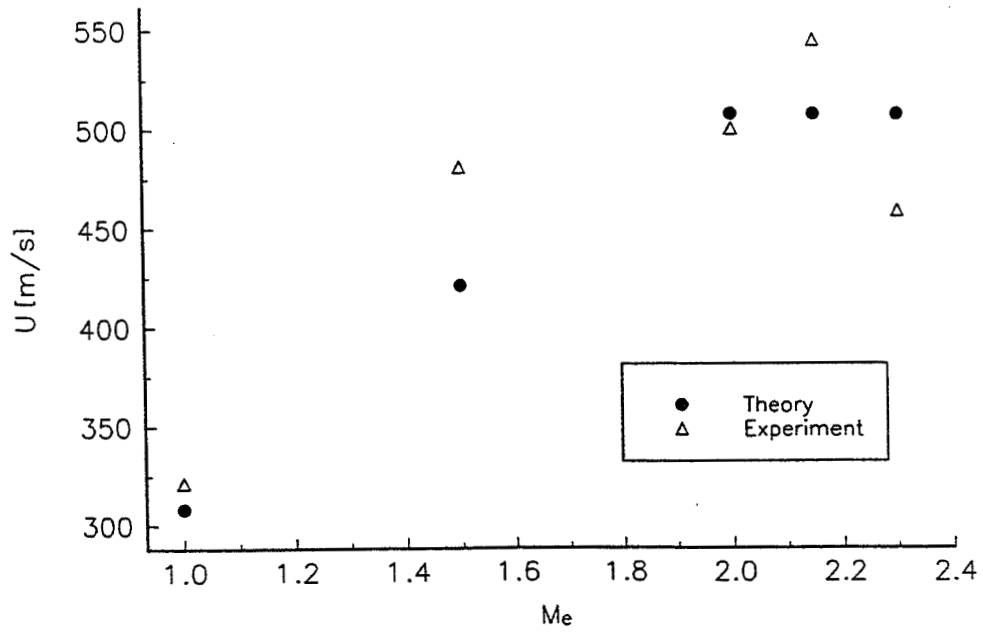

Uncertainty for velocity and thermodynamic properties.

Error Source	Maximum Error in U %	Maximum Error in T %	Maximum Error in ρ %	Maximum Error in P %
I	1.5	1.2	4.0	1.2
α	0.07	0.01	-	0.01
ρ	3.1	0.44	-	3.6
f_0	9.5	5.63	-	5.6
A_i	1.3	0.60	-	0.55
Total	9.7	5.7	4.0	6.2

CURRENT ACTIVITIES

- Extending FPV to Three-Camera Configuration for Simultaneous Measurements of all Three Components of Instantaneous Velocity on a Plane
- Extending FPV to Three-Camera Configuration for Simultaneous Measurements of all Three Components of Instantaneous Velocity and Thermodynamics Properties on a Point
- Improving Accuracy and Robustness of the Techniques

NEAR FUTURE PLANS

- To Advance FRS & FPV to Real-Time Visualizations and Measurements

52-34
79374

RAYLEIGH LIGHT SCATTERING FOR CONCENTRATION MEASUREMENTS IN TURBULENT FLOWS

William M. Pitts
National Institute of Standards and Technology
Gaithersburg, Maryland

232654

208.

INTRODUCTION

Despite intensive research efforts over a number of years, an understanding of scalar mixing in turbulent flows remains elusive. An understanding is required because turbulent mixing has a pivotal role in a wide variety of natural and technologically important processes. As an example, the mixing and transport of pollutants in the atmosphere and bodies of water are often dependent on turbulent mixing processes. Turbulent mixing is also central to turbulent combustion which underlies most hydrocarbon energy utilization in modern societies as well as unwanted fire behavior. Development of models for combusting flows is crucial for more efficient utilization of limited hydrocarbon fuel resources, reduction in environmentally harmful pollutants, more efficient chemical processes, and for the prediction of hazard associated with unwanted fire. However, an understanding of scalar mixing is required before useful models of turbulent mixing and, ultimately, turbulent combustion can be developed.

An important subset of turbulent flows is axisymmetric turbulent jets and plumes because they are relatively simple to generate, and because they provide an appropriate test bed for the development of general theories of turbulent mixing which can be applied to more complex geometries and flows.

During this talk we will focus on a number of experimental techniques which have been developed at NIST for measuring concentration in binary (i.e., consisting of two components) axisymmetric turbulent jets. In order to give a flavor for the value of these diagnostics, some of the more important results from earlier and on-going investigations will be summarized. Topics to be addressed include the similarity behavior of variable-density axisymmetric jets [1],[2], the behavior of absolutely unstable axisymmetric helium jets [3], and the role of large-scale structures and scalar dissipation in these flows [4],[5].

RAYLEIGH LIGHT SCATTERING FOR CONCENTRATION MEASUREMENT

Rayleigh light scattering refers to the elastic scattering (i.e., no change from the incident wavelength) of light by molecular species. For a mixture of m gases, the intensity of RLS is given by

$$I(90^\circ) = N \left(\sum_{j=1}^m \sigma_j(90^\circ) X_j \right) I_o \tag{1}$$

where N is the total number density of molecules, σ_j is the Rayleigh scattering cross section for the wavelength of incident light, X_j is the mole fraction of species j , and I_o is the incident light irradiance. This expression assumes that the molecules are isotropic. For this case the scattered light has the same polarization as the incident light. More complicated expressions are required for scattering from anisotropic molecules which depolarize the scattered light. [6]

A typical RLS experiment involves monitoring the scattered light intensity from a short length of a laser beam located within a gas flow. The information which can be determined from the signal depends on the type of gas which is located within the observation volume. For isothermal binary mixtures it is typical to perform calibrations of the RLS scattering intensities for the two unmixed gases. The resulting expression for calculating the mole fraction of gas 2, $X_2(t)$ where the t dependence indicates that X_2 may fluctuate with time, is quite simple,

$$X_2(t) = \frac{I(t) - I_1}{I_2 - I_1} \quad (2)$$

Here $I(t)$ is the time-dependent intensity of RLS from the volume containing the gas mixture of interest, and I_1 and I_2 are observed RLS intensities for scattering from pure gases 1 and 2. The mole fraction of gas 1 is simply obtained from Eq. (2) as $X_1(t) = 1 - X_2(t)$. Once mole fractions are available, mass fractions, $Y_1(t)$ and $Y_2(t)$, can be calculated using standard formulas. An important advantage of Eq. (3) is that only relative values of RLS intensity need to be recorded. It is not necessary to measure absolute intensities. This greatly simplifies the optical system and analysis requirements.

An important limitation of RLS is that resonant scattering from small particles (Mie scattering), which are generally present in laboratory environments, and surfaces (glare) can be much stronger than RLS. These light sources act as interferents and noise sources and, in worst cases, can preclude RLS measurements.

RLS MEASUREMENT OF CONCENTRATION IN TURBULENT FLOW FIELDS

By using either pulsed (e.g., [7]) or continuous wave (cw, e.g., [8]) high-powered lasers to induce RLS, it is possible to measure concentration in turbulent flow fields of two gases with high temporal and spatial resolution. Pulsed lasers are usually employed to make multipoint (line or planar) measurements. These lasers generally generate very short pulses (in the ns to μ s range) which "freeze" the turbulent motion, but have low repetition rates (typically 10 Hz) which preclude following the time behavior of the flow. cw lasers have usually been used for point measurements, but measurements along a line defined by a laser beam have also been demonstrated. [9] Data rates for such measurements are generally high enough to allow real-time recordings of RLS scattering to resolve the turbulent concentration fluctuations within a flow.

EXPERIMENTAL SYSTEMS DEVELOPED AT NIST

FLOW SYSTEMS

Over the years a series of flow systems and experimental configurations have been developed at NIST for the measurement of concentration in turbulent flow fields generated by the flow of axisymmetric jets into a second gas. The focus has been on the development of systems capable of real-time measurements having high spatial and temporal resolution. Only brief descriptions of the experimental systems are provided here. Interested readers are referred to the cited references for additional details.

Two different approaches have been used to overcome the problem of Mie scattering from small particles interfering with RLS measurements of concentration. In our initial experiments a coflow system was used in which an axisymmetric gas jet from a 6.35 mm pipe entered a slow coflow of a second gas contained within a square glass enclosure having 10 cm sides. [1],[6],[10] Both flows were filtered to remove particles. Most turbulent studies using RLS have used similar configurations to limit Mie scattering interferences since accurate measurements have proven difficult in the presence of particles. [11]

Recently a new experimental system, termed the Rayleigh Light Scattering Facility, has been developed to provide a large enough dust-free volume to allow measurements of free jets. [12] A flow of air filtered by high efficiency particle filters is used to sweep particles from within a 2.3 m long by 2.3 m diameter cylindrical test section. Experiments are performed by turning off the blowers and waiting for flow transients to dissipate. This system provides a nearly ideal environment for RLS studies of mixing since both Mie scattering and glare are barely detectable.

Jets within the enclosure have been formed either from the pipe flow described above or by using a contoured nozzle designed to generate a top hat velocity profile at the jet exit. The enclosure includes a three-dimensional positioning system for orienting the flow field relative to the optics which are fixed within the enclosure.

SINGLE-POINT MEASUREMENTS OF CONCENTRATION

The use of RLS scattering for concentration measurements in turbulent flows has been discussed in detail by Pitts and Kashiwagi. [6] The optical system required for single-point RLS measurements is fairly simple. It consists of a lens to focus the laser beam from an 18 W Ar ion laser to a narrow waist (50 μm is a typical diameter) and an $f/2$ light collection system for imaging the scattered RLS at right angles onto a pinhole which defines the length of the observation volume. Light is then detected by a photomultiplier tube for which the current output (proportional to detected light intensity) is converted to a voltage, digitized, and stored in the memory of a computer for later analysis. Data sets consisting of several hundred thousand measurements can be recorded.

Since RLS is a relatively weak optical process, the largest noise source is usually the Poisson statistics associated with photon detection, which is equal to the square root of the number of detected photons. [13] The intensity of RLS varies with the gas pairs studied so the noise level for a given experiment depends on the gases in the mixture. However, it has been shown that the current experimental arrangement allows measurements of real-time concentration having accuracies better than 1% of full scale at data rates of several thousand Hz for observation volumes as small as 0.0003 mm^3 . [6] By careful design of the optical system, Dowling and Dimotakis have achieved somewhat higher temporal and spatial resolution. [14]

REAL-TIME LINE MEASUREMENTS OF CONCENTRATION

Single-point measurements are recorded by using optics to isolate a short length of scattered laser light from a laser beam. Clearly, if it were possible to rapidly image several individual lengths of the laser beam onto a number of detectors it would be possible to record real-time concentration fluctuations at a number of points simultaneously. A line camera system has been developed which is capable of recording propane (which has a particularly strong RLS signal) mole fraction at 128 adjacent points with a maximum line data rate of 2.37 kHz. The camera design required the incorporation of an image intensifier. Due to the relatively high noise level associated with the line scanner used in the camera and the desire for high temporal response, it was necessary to use a generation I image intensifier equipped with a high-speed phosphor. An earlier version of the line camera has been described in detail. [9] It incorporated a two-stage, generation I image intensifier equipped with a P-46 phosphor. A later version of the camera having a thirteen-fold improvement in signal-to-noise ratio utilizes a three-stage image intensifier with a P-47 phosphor screen. [15]

The line camera is designed for 1:1 focusing of a 14.7 mm length of the laser beam onto the image intensifier. A 4:1 fiber optic taper couples the output of the image intensifier to the 3.2 mm length of the 128 pixel line scanner. The effective spatial resolution is ≈ 0.2 mm. The line scanner limits the maximum line read-out

rate to 2.37 kHz. The output of the line scanner is digitized and stored by a computer. Many thousands of line scans can be recorded during a single experiment.

COMBINED INSTANTANEOUS TWO-DIMENSIONAL AND REAL-TIME LINE MEASUREMENTS OF CONCENTRATION

Recently, Richards and Pitts have recorded two-dimensional images of RLS using a cooled CCD array to image RLS from a sheet generated by passing the second harmonic (532 nm wavelength) of a Nd⁺³/YAG laser through a series of cylindrical lenses. [5] This experimental approach was first used by Escoda and Long. [7] Since the laser generates a 10 ns pulse, the flow field is "frozen" and two-dimensional images of concentration can be derived.

In addition to the sheet from the YAG laser, the cw Ar ion laser beam was passed through the flow field such that it was aligned parallel to and just downstream of the laser sheet. The real-time line camera was used to record measurements of concentration at this position. In this way it was possible to monitor the concentration fluctuations generated by a flow whose two-dimensional distribution was recorded just upstream an instant earlier.

RESULTS

SIMILARITY BEHAVIOR OF VARIABLE-DENSITY FLOWS

It has been known for some time that constant-density turbulent axisymmetric jets develop a self-similar behavior in which only a single length scale is necessary to characterize the time-averaged and fluctuation concentration profiles. (e.g., [16]) An important question was whether or not jets having global density variations due to density differences between the jet and surroundings would also develop self-similar behavior with increasing downstream distance as their densities approached that for the ambient gas due to continual entrainment of surrounding fluid into the jet.

Earlier experiments (including work from our laboratory) indicated that such flows did not achieve self-similar behavior. [1],[17] The Rayleigh light scattering facility has allowed careful measurements of the scalar and fluctuation fields for jets of helium, methane, and propane entering ambient air for which buoyancy effects were unimportant. [2] The findings of this investigation show that these flow fields do achieve full self-similar behavior. Profiles for concentration fluctuations also obey similarity relationships. The similarity profiles agree well with those measured for constant density jets by Dowling and Dimotakis. [14]

Propane jet measurements were recorded for both pipe and contoured-nozzle flows, which are expected to have quite different initial velocity profiles and turbulence levels. The results indicate that the final similarity state achieved by the variable-density flows is independent of the initial density ratio as well as the velocity distribution.

Very recently the single-point RLS technique has been used to characterize the mixing behavior in the near-field of helium jets from a contoured nozzle which are known to be absolutely unstable. Absolutely unstable jets develop intense and highly coherent oscillations in their near-field shear layers. [18] The strength of the effect results in a number of interesting vortical interactions which can lead to the formation of "side jets", a process in which jet fluid is vigorously ejected into the surrounding ambient fluid. As a result of side-jet formation, the near-field mixing rate is substantially enhanced compared to axisymmetric jets which do not display this behavior.

The RLS scattering measurements have been used to characterize mixing processes in the jet shear layer as well as in the side jets outside of the shear layer. These measurements have identified the parameters which control the strength of the absolute instability, provided insights into the vortical interactions which ultimately lead to the formation of side jets, and demonstrated that the strength of side jets is proportional to the strength of the instability in the shear layer. The side jets themselves have been shown to consist of nearly pure jet fluid, which indicates that they must come from the jet core. They are highly localized in space and tend to rotate randomly about the parent jet.

ORGANIZED MOTION AND SCALAR DISSIPATION IN AXISYMMETRIC JETS

The line camera has been used to record real-time line images of concentration for a propane jet flowing from a nozzle into quiescent air. Measurements were made for various radial sections located 40 radii downstream from the jet exit. Three thousand line scans (384,000 individual concentration measurements) were recorded during a single experiment. The availability of such large data sets allows a number of statistical properties for the concentration field to be calculated. The time-averaged radial mass fraction profile is found to be in excellent agreement with earlier measurements in the same flow system. [2]

These real-time line measurements reveal that strong mixing occurs near the centerline. As one moves further from the centerline, the flow becomes intermittent (both mixed jet fluid and ambient air are observed). The time structure found for the turbulent fluid in this region is quite distinctive. For a particular radial location, it is observed that when the turbulent fluid first appears (i.e., at the end of a time period during which only air is present) there is a very rapid increase in jet fluid concentration. This rapid increase is followed by much slower fluctuations in concentration which gradually drop off until ambient air is once again observed. Such a behavior has often been noted in single-point scalar measurements and has been referred to as "ramp-like" structures. The line images demonstrate that ramp-like structures extend across a large radial extent of the flow. This is a clear indication that the motions which generate large-scale turbulent structures (LSTS) are organized. Previous measurements suggest that the downstream edges of the structures are the result of strong ejections of fluid from the central region of the jet, and that air entrainment occurs in upstream regions of the LSTS. [19]

The line camera results have also been used to estimate values for the time-resolved component of scalar dissipation in the radial direction (χ_r). Scalar dissipation, defined as

$$\chi = 2D\nabla Y \cdot \nabla Y, \quad (3)$$

where D is the binary molecular diffusion coefficient and Y is the mass fraction of jet fluid, is a measure of molecular mixing rate in turbulent flows. Values of χ play a central role in the modeling of turbulent mixing in both isothermal and combusting turbulent flows.

The space-time images of χ_r show that rapid spatial variations in the rate of mixing occur over small regions of space in the interior regions of the jet, but that large contiguous regions of rapid mixing are associated with large-scale structures on the outer edges of these flows.

The last set of results to be discussed are preliminary measurements in which instantaneous two-dimensional images of propane mole fraction have been recorded simultaneously with real-time line measurements at a location just downstream of the sheet location. The purpose of these measurements is to gain insight as to how the structures observed in the line measurements are related to the turbulent structures observed in instantaneous two-dimensional images and how LSTS are modified as they convect downstream.

CONCLUSIONS

A number of experimental diagnostics for characterizing scalar fields in turbulent flows of two gases have been developed at NIST. Unique capabilities include experimental systems which allows measurements of free shear flows and a camera capable of recording real-time concentration at 128 points along a line simultaneously. These techniques have been used to 1) demonstrate that variable density jets obey similarity behavior, 2) characterize the boundary-layer structure and side jets in absolutely unstable axisymmetric jets, 3) demonstrate that LSTS play a fundamental role in the mixing behavior of axisymmetric jets, and 4) provide an improved understanding of scalar dissipation and its dependence on LSTS. Results of these studies along with those from other laboratories will ultimately provide the understanding necessary to develop effective models for predicting mixing behaviors of complicated turbulent flows and combustion systems.

REFERENCES

1. W. M. Pitts, *Exp. Fluids* **11** (1991) 125.
2. C. D. Richards and W. M. Pitts, *J. Fluid Mech.* **254** (1993) 417.
3. A. W. Johnson and W. M. Pitts, manuscript in preparation.
4. C. D. Richards and W. M. Pitts, manuscript in preparation
5. C. D. Richards and W. M. Pitts, unpublished work.
6. W. M. Pitts and T. Kashiwagi, *J. Fluid Mech.* **141** (1984) 391.
7. M. C. Escoda and M. B. Long, *AIAA J.* **21** (1983) 81.
8. S. C. Graham, A. J. Grant, and J. M. Jones, *AIAA J.* **12** (1974) 1140.
9. W. M. Pitts, *Fifth International Congress on Applications of Lasers and Electro-Optics, Vol. 58-Flow and Particle Diagnostics*, The Laser Institute (1986), p. 7.
10. W. M. Pitts, *Exp. Fluids* **11** (1991) 135.
11. H. G. Green, *J. Phys. E: Sci. Instrum.* **20** (1987) 670.
12. N. Bryner, C. D. Richards, and W. M. Pitts, *Rev. Sci. Instrum.* **63** (1992) 3629.
13. E. R. Pike, *Riv. Nuovo Cim.* **1** (Numero Speciale) (1969) 277.
14. D. R. Dowling and P. E. Dimotakis, *J. Fluid Mech.* **218** (1990) 109.
15. W. M. Pitts, *23rd Symp. (Intl.) Comb.*, The Combustion Institute (1990), p. 661.
16. J. O. Hinze, *Turbulence*, McGraw-Hill (1975).
17. F. C. Gouldin, R. W. Schefer, S. C. Johnson, and W. Kollmann, *Prog. Energy Combust. Science*, **12** (1986), 257.
18. P. A. Monkewitz and K. D. Sohn, *AIAA J.* **26** (1988) 911.
19. R. Chevray and N. K. Tutu, *J. Fluid Mech.* **88** (1978), 133.

COWORKERS

NBS and NIST Staff

Dr. Takashi Kashiwagi

Dr. Bernie McCaffrey

Sid Weiser

Nelson Bryner

Rik Johnson

NRC Postdoctorals

Dr. Cill Richards

Dr. Art Johnson

University of Maryland

Professor Jim Wallace

Dr. K. C. Muck

OUTLINE

1. Introduction to turbulent jets and real-time Raleigh light scattering measurements of concentration in binary turbulent jets
2. Rayleigh Light Scattering Facility
3. Point measurements in variable density jets
4. Point measurements in absolutely unstable helium jets
5. Real-time line camera for measurements of concentration
6. Line-camera results in turbulent propane jet
7. Combined real-time line camera and instantaneous two-dimensional measurements of concentration in turbulent propane jet
8. Summary

$C_3H_8/air, Re = 3960$

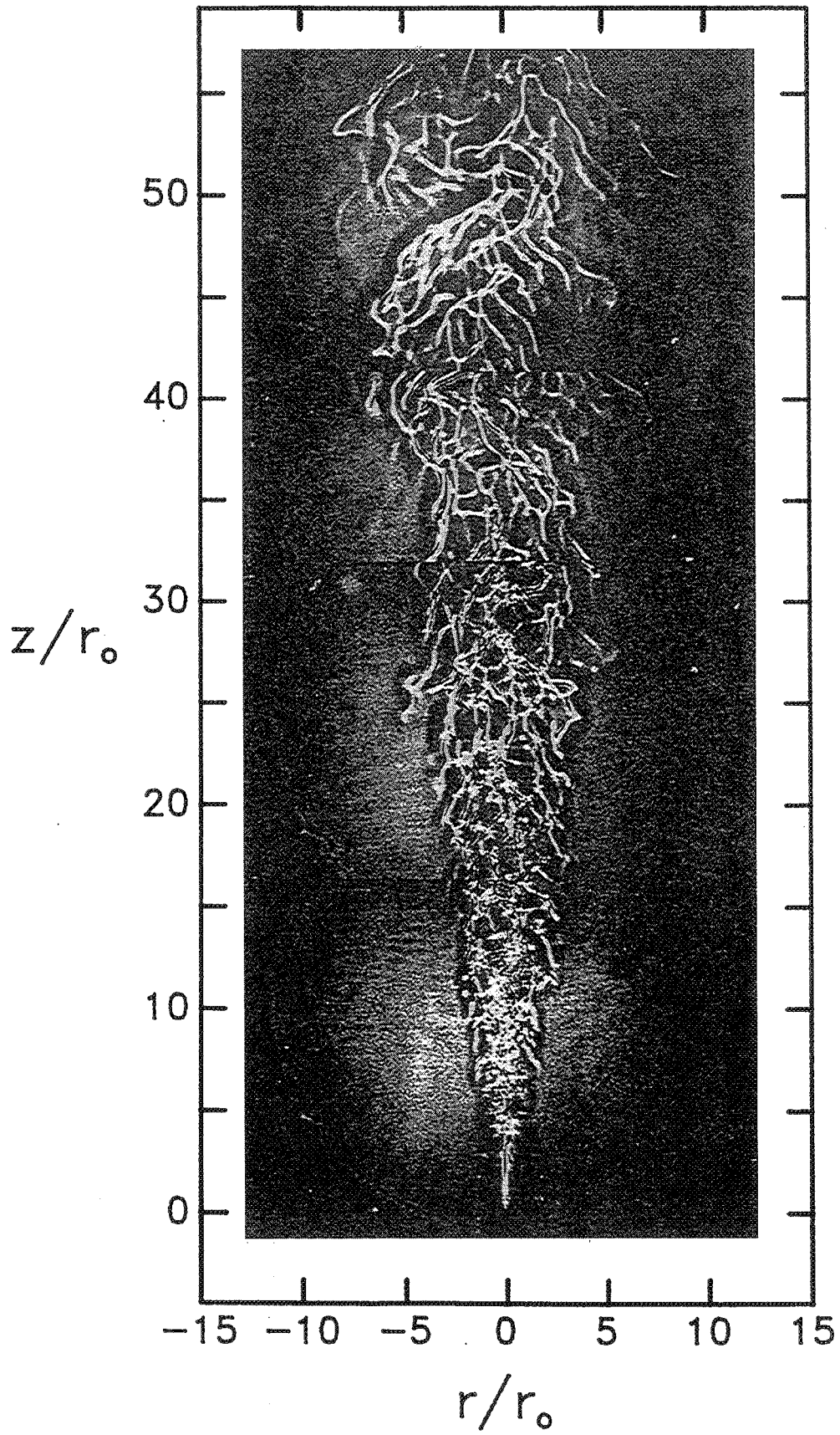

RAYLEIGH LIGHT SCATTERING

$$R_p = I_L \eta_L l \Omega \eta_C \epsilon N \sum_{j=1}^M \sigma_j X_j$$

$$R_p = KN \sum_{j=1}^M \sigma_j X_j$$

For Binary Gas Mixture:

$$X_2(t) = \frac{I(t) - I_1}{I_2 - I_1}$$

with I_1 and I_2 equal to the scattering from the pure gases 1 and 2

RAYLEIGH LIGHT SCATTERING

Advantages:

- Relatively strong signal allows real-time measurements
- Signal due to gas composition

Disadvantages:

- Scattering occurs from all molecules
- Light is elastically scattered
 - glare
 - Mie scattering

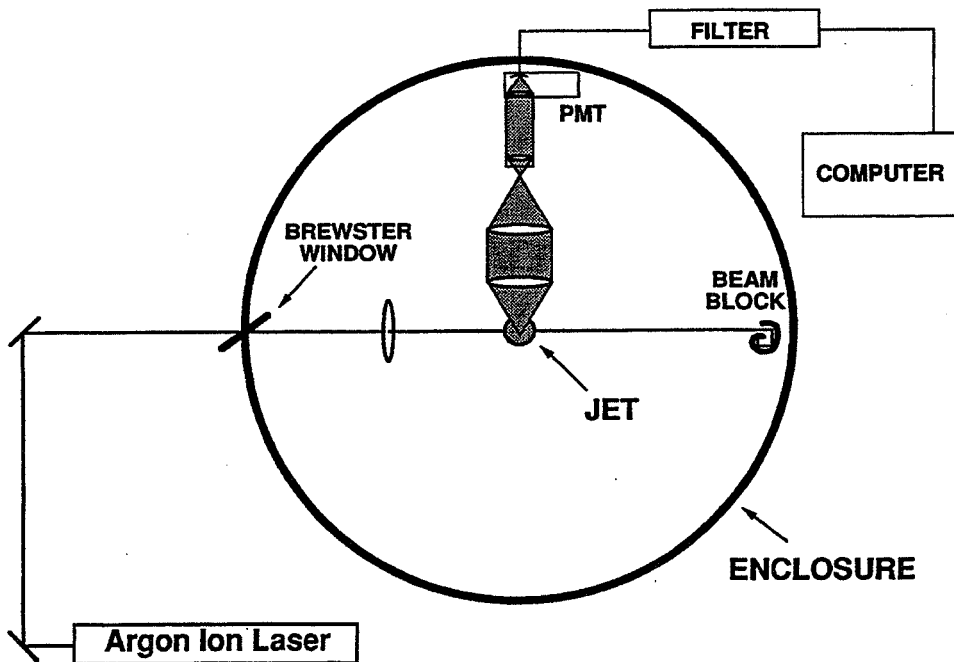
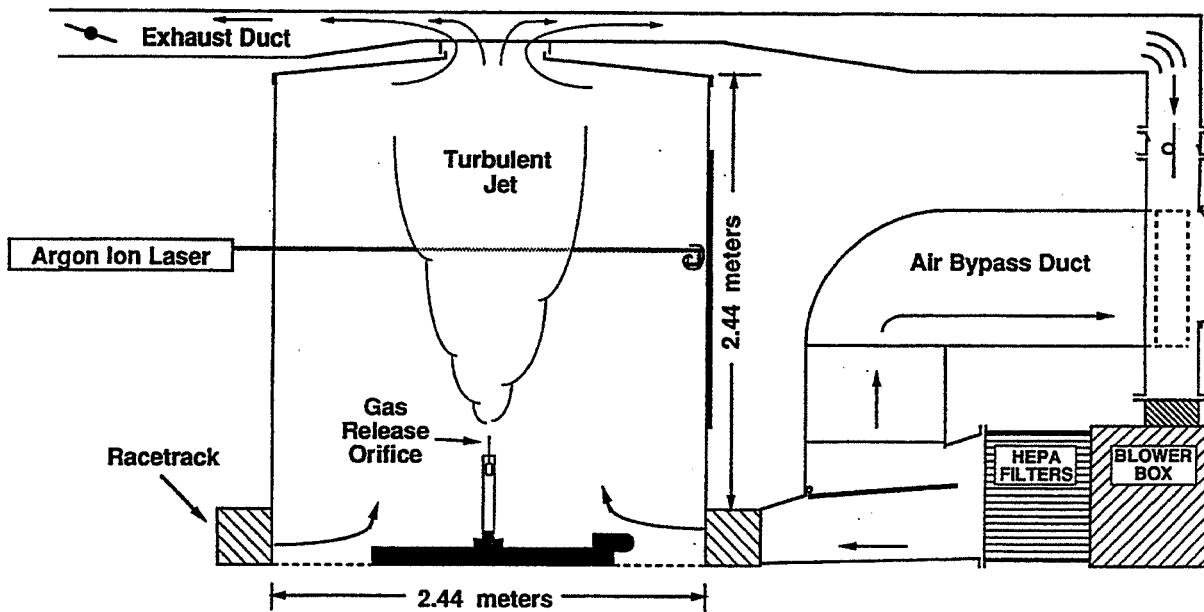

GLOBALLY UNSTABLE JET PRODUCING SIDE-JETS

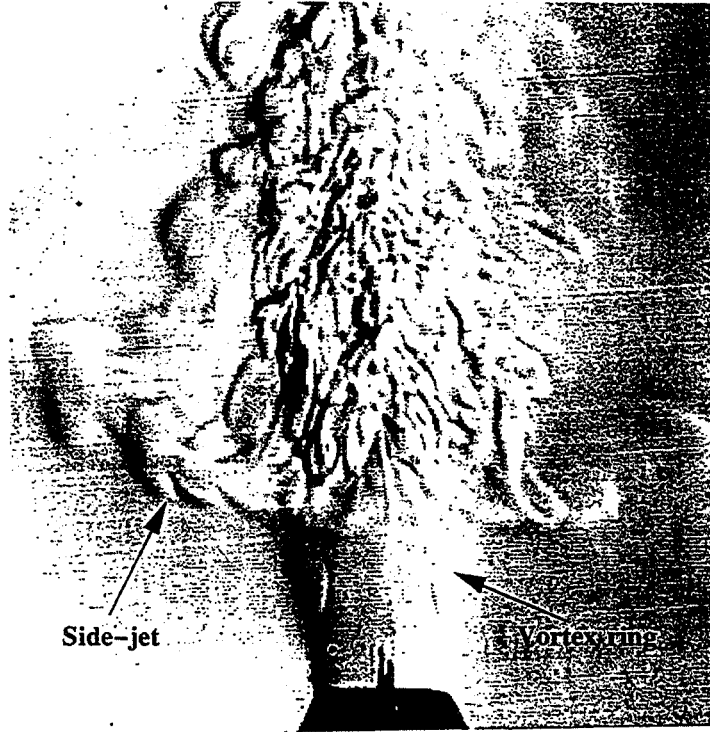

FULL SIMILARITY, ALL GASES

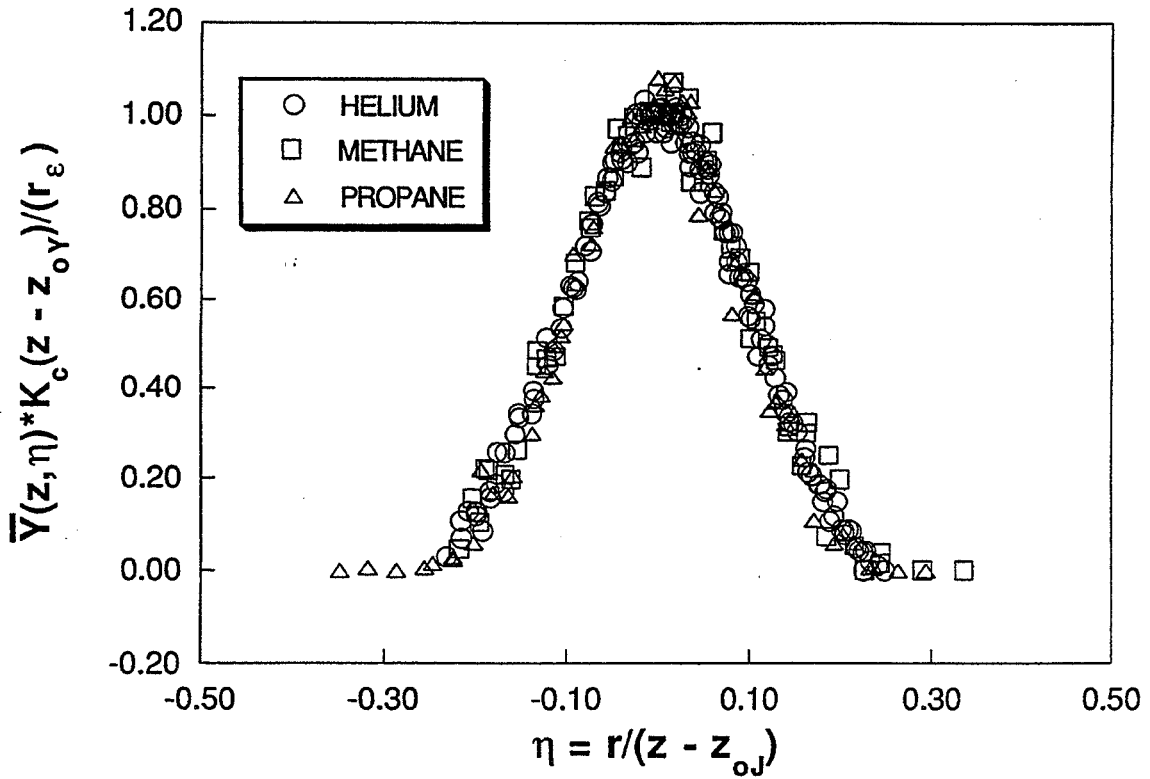

CONCENTRATION TIME-TRACES (Axial direction, shear layer)

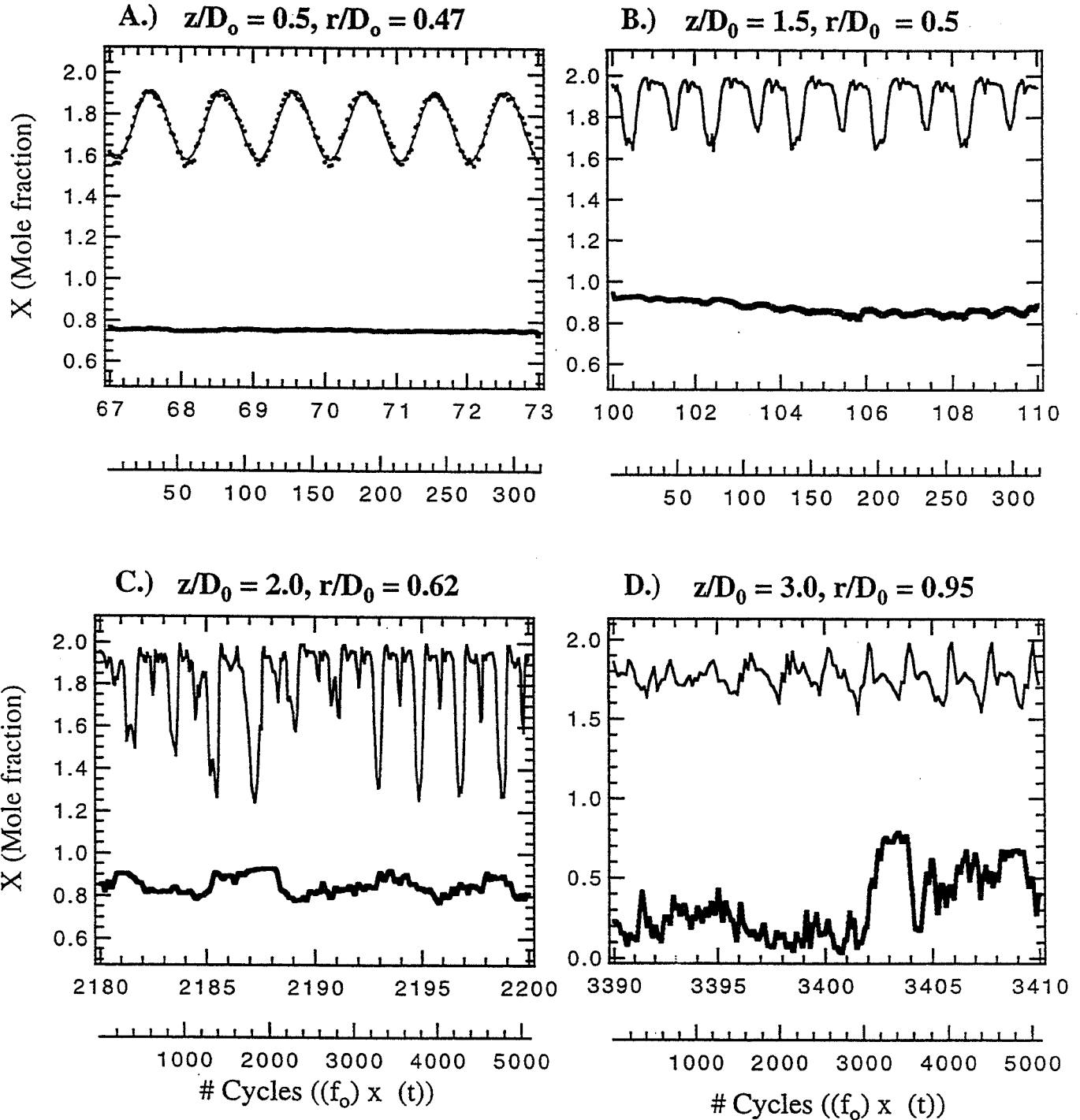

Simultaneous velocity, concentration, angle (Side-jet fluid)

$U_o = 19 \text{ m/s}$, $z/D_o = 1.75$, $r/D_o = 1.5$, $R_p = 0.14$, $f_o = 702 \text{ Hz}$.

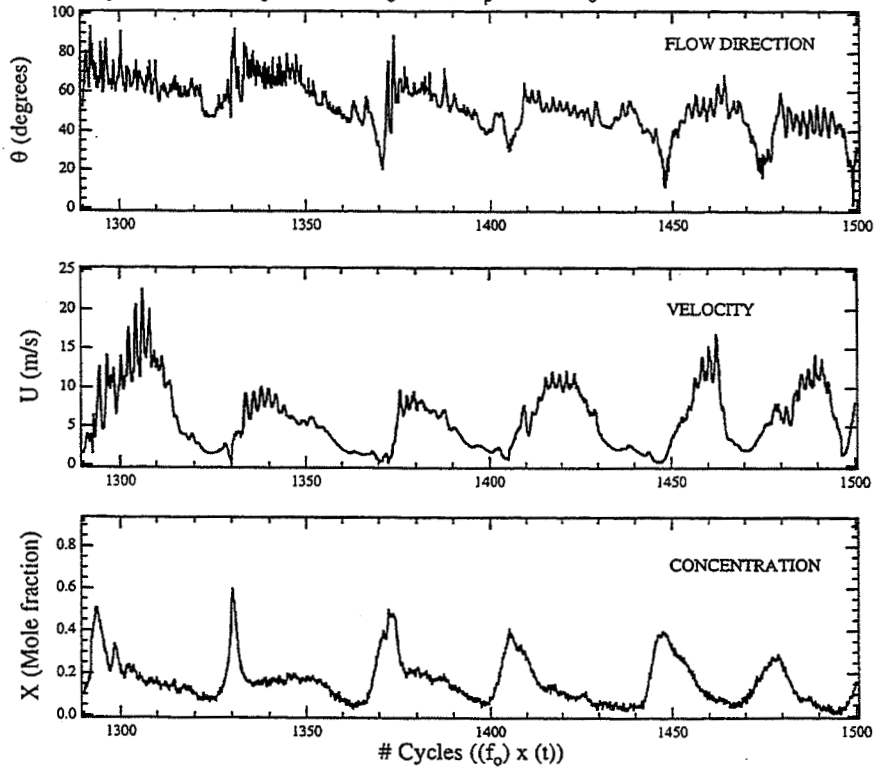

Near-Field Concentration / Mixing Enhancement

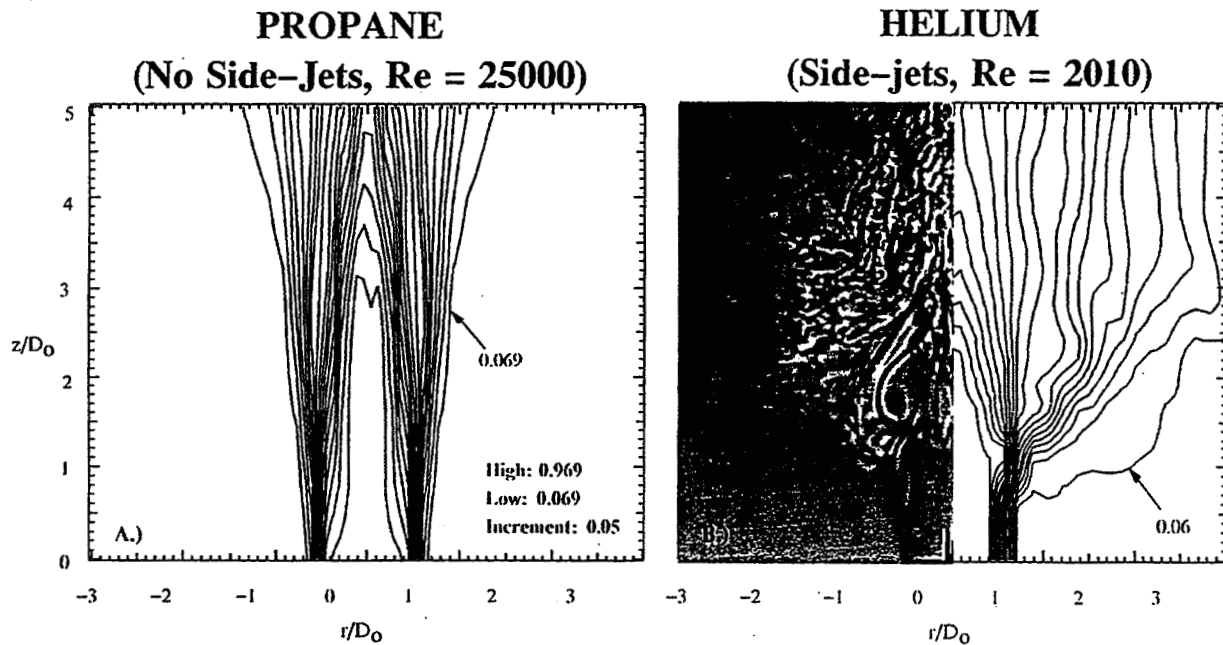

Photograph of laser beam in Rayleigh Light Scattering Facility

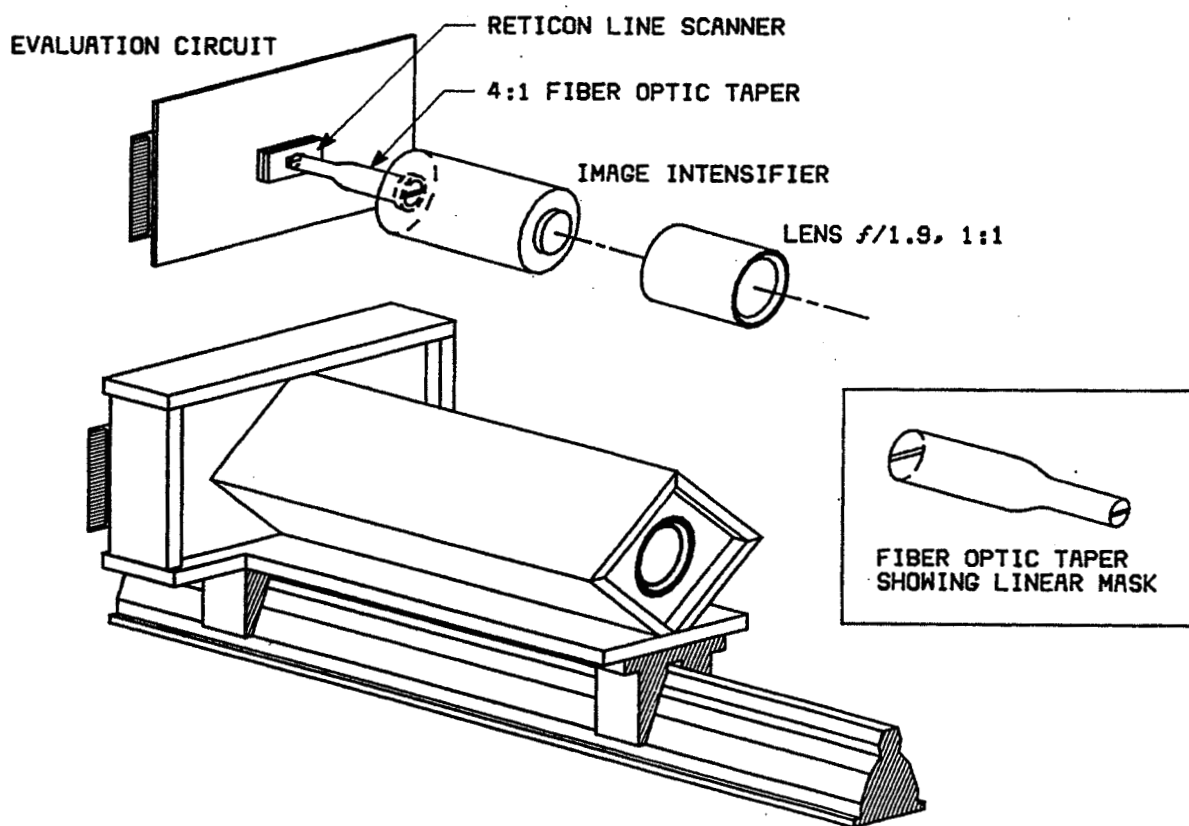

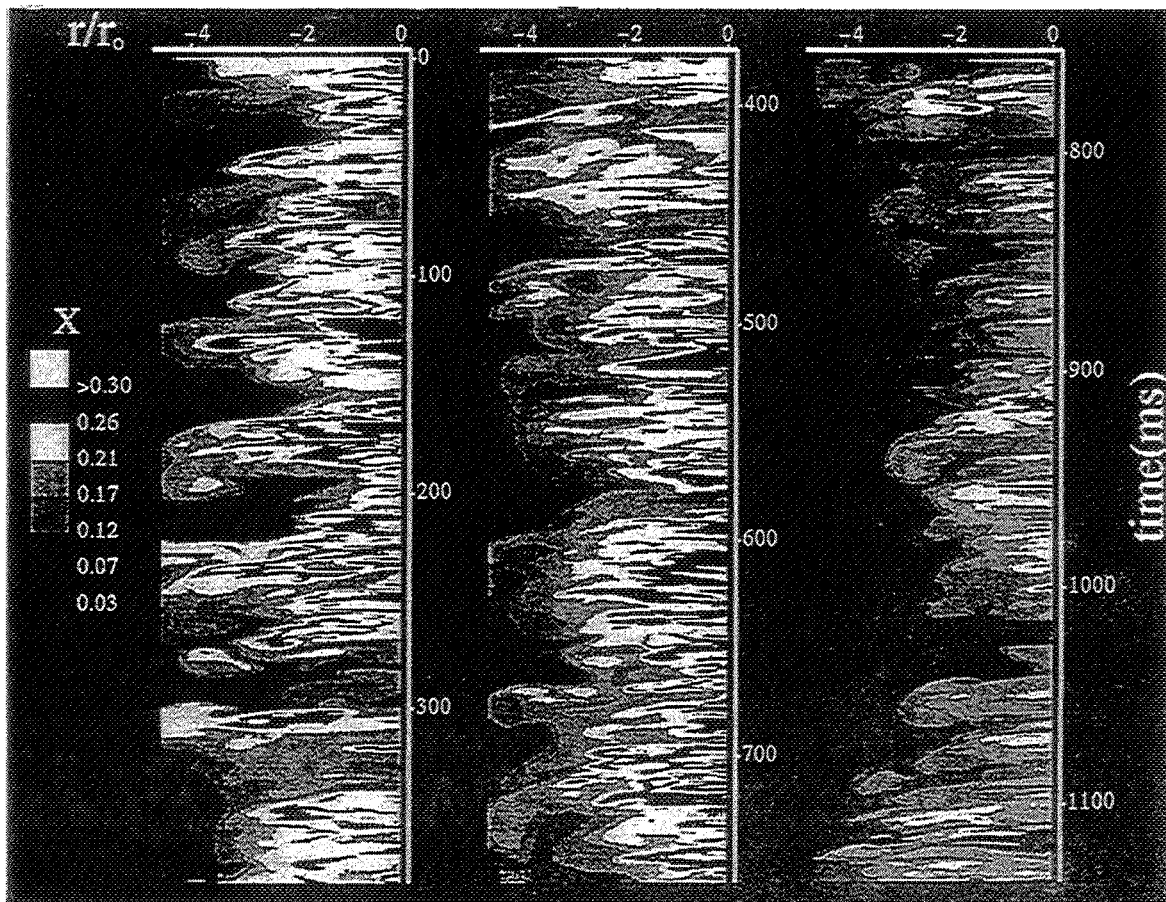
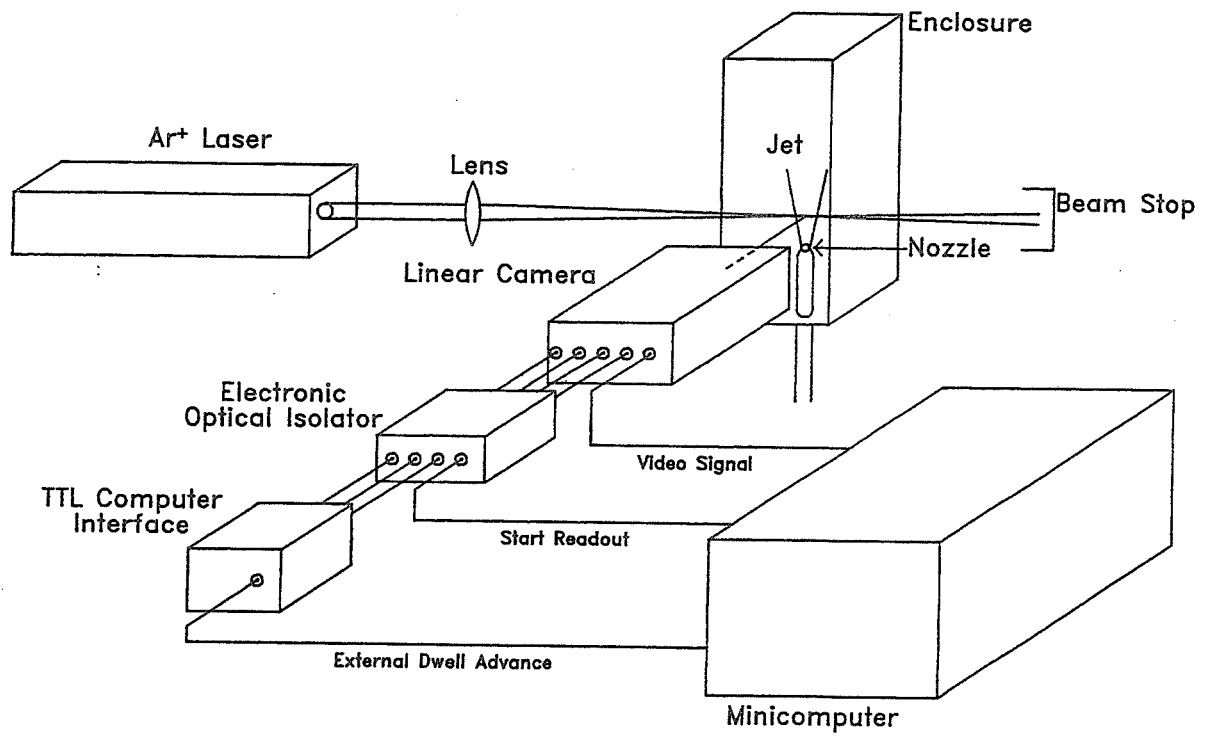

SCALAR DISSIPATION

- Rate of molecular mixing

$$\chi = \chi_z + \chi_r + \chi_a = 2D \left[\left(\frac{\partial \xi}{\partial z} \right)^2 + \left(\frac{\partial \xi}{\partial r} \right)^2 + \left(\frac{\partial \xi}{\partial a} \right)^2 \right]$$

Widely studied to understand:

- 1) Isotropy of mixing in turbulent flows
- 2) Chemistry/turbulence interactions in turbulent diffusion flames

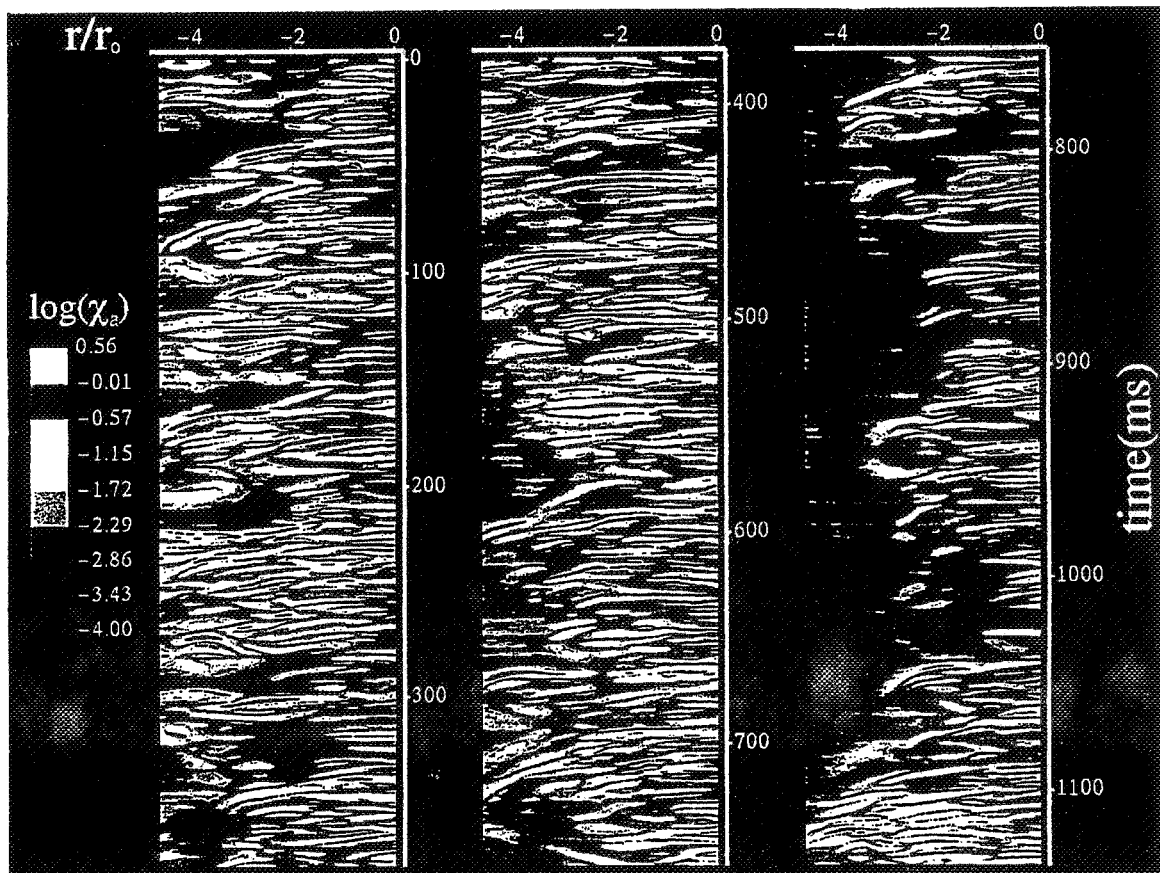

Photograph of two-dimensional slice of axisymmetric jet using Mie scattering

Photograph of skier, baseball player, and football player taken with a line camera

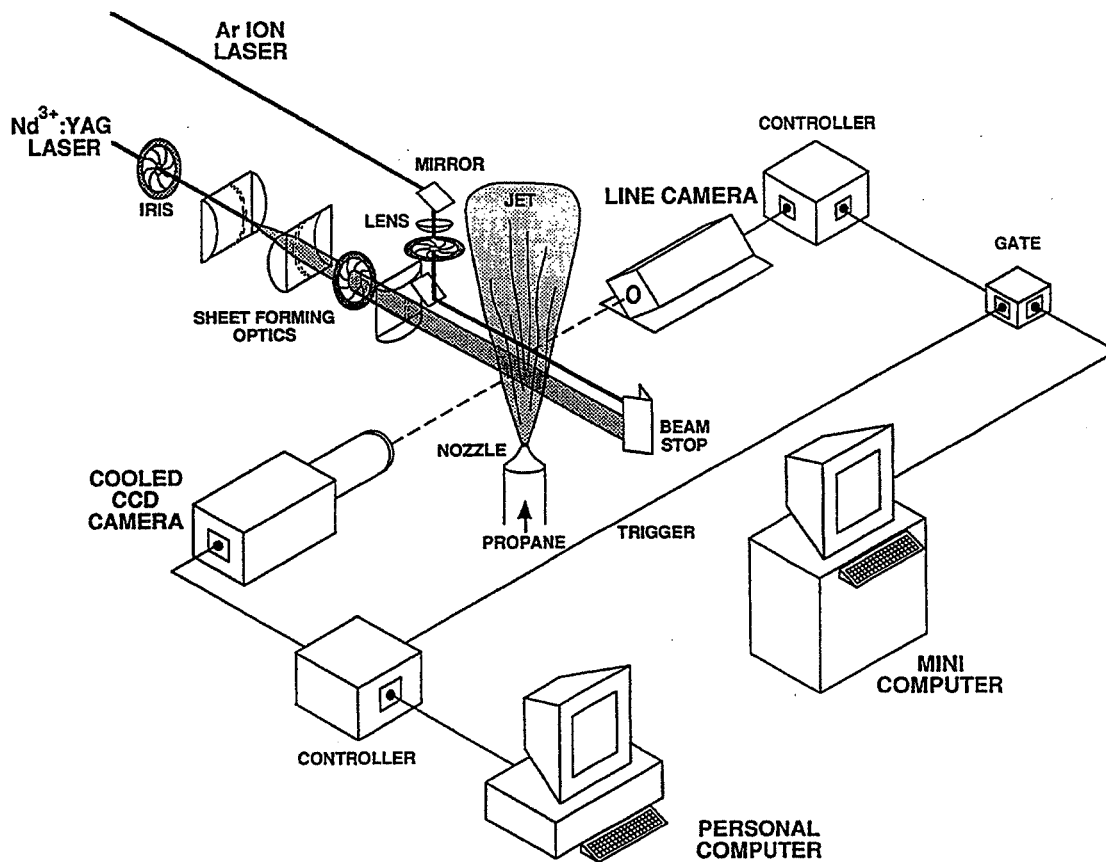

Photograph of $\text{Nd}^{+3}/\text{YAG}$ two-dimensional laser sheet and Ar ion laser beam

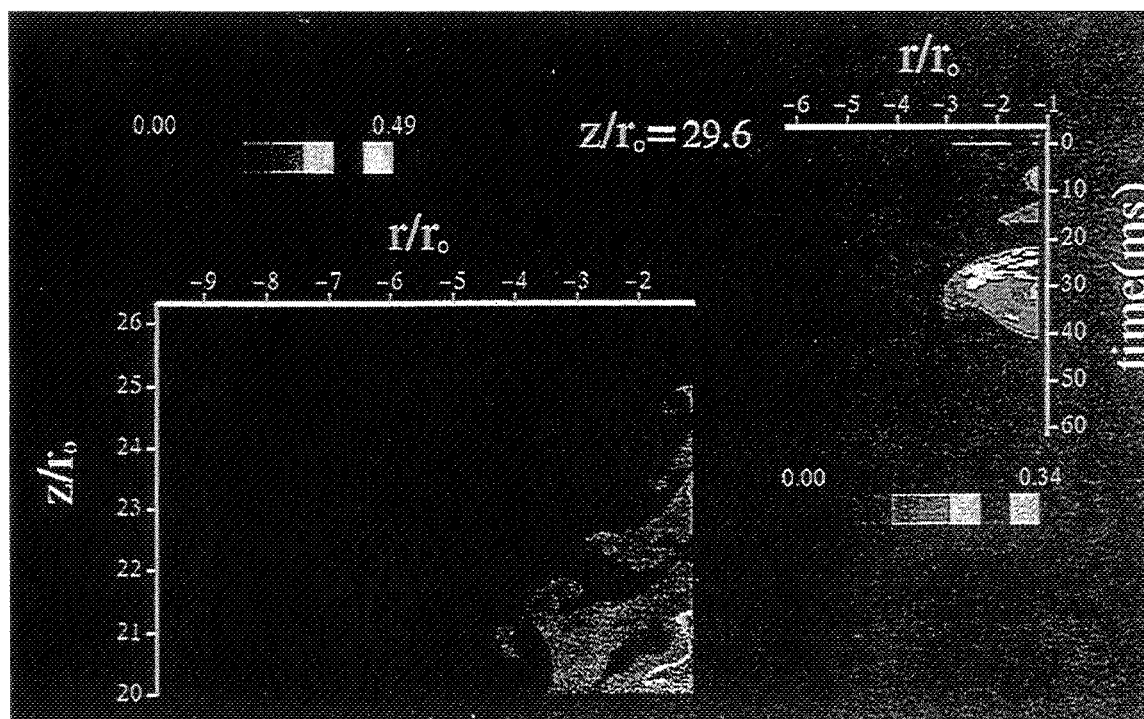

SUMMARY

- Experimental Systems
 - Rayleigh Light Scattering Facility
 - Real-time line camera
 - Combined instantaneous two-dimensional and line camera imaging of concentration
- Measurements discussed
 - Similarity of variable density flows
 - Shear-layer structure and side jets in absolutely unstable jets
 - Large-scale turbulent structures and scalar dissipation
- Current Efforts
 - Measurements in a helium buoyant jet
 - Simultaneous point measurements of concentration and two components of velocity in propane and methane jets

53-34
79375

VELOCITY MEASUREMENT BY SCATTERING FROM INDEX OF REFRACTION
FLUCTUATIONS INDUCED IN TURBULENT FLOWS

Lars Lading and Mark Saffman
Riso Research Center
Denmark

032655

and

12 p.

Robert Edwards
Case Western Reserve University
Cleveland, Ohio

Induced Phase Screen Scattering

What is it?

- Scatter light from from weak index of refraction fluctuations induced by turbulence.

Basic Assumptions and Requirements

- **Quasi-elastic interaction**
- **Weak interaction, i.e. $\langle(\Delta n)^2\rangle \ll \langle n\rangle^2$**
- **The *probing scale* must be larger than the mean free path or the Debye length (plasma).**
- **Small scales are used to sample the dynamics of larger scales.**
- **The persistence time of the refractive index pattern must be longer than the residence time.**
- **The size of the measuring volume must be smaller than the scale to be measured.**

Scattering and detection:

Scale requirements \Rightarrow

forward scattering

far infrared light ($\lambda = 10 \mu\text{m}$)

Weak interaction \Rightarrow infrared light (or shorter λ)

Coherent detection (phase fronts parallel over the detector area):

Reference beam detection because:

parametric amplification needed

simpler statistics

- Scale selected in the usual way by heterodyne scattering angle and laser wavelength.

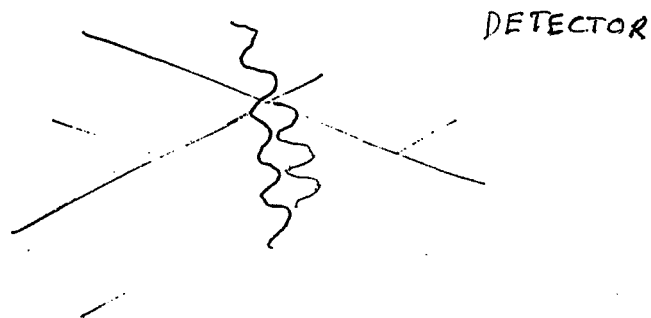

$$i(t) = \int e^{-i\mathbf{k}\cdot\mathbf{r}} F(\mathbf{r}) S(\mathbf{r}, t) d\mathbf{r}$$

$$i(t) = \int \hat{F}(\mathbf{k} - \mathbf{k}') \hat{S}(\mathbf{k}') d\mathbf{k}'$$

$\hat{S}(\mathbf{k}')$ is the Fourier Transform of the spatial distribution of the scattering power.

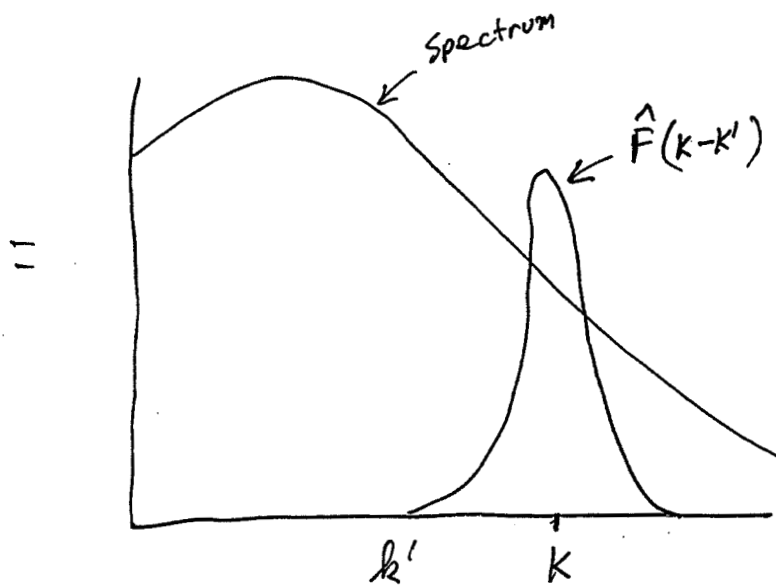

Here, fluctuations are induced by turbulence itself - e.g. Noise is a manifestation of pressure fluctuations.

Temperature fluctuations can be induced by turbulence in a gas flow

Local electron number density can be induced by turbulence in a plasma.

Divide fluctuations into two types:

1) Propagating - Sound Waves

2) Non-propagating - Temperature Fluctuations

$$dn = \beta_1 dT + \beta_2 dP$$

For a moving, compressible fluid

$$\rho \hat{C}_p \left(\frac{\partial (T - T_0)}{\partial t} + \mathbf{v} \cdot \nabla (T - T_0) \right) =$$

$$\alpha \rho \hat{C}_p \nabla^2 (T - T_0) - \left(\frac{\partial p}{\partial t} + \mathbf{v} \cdot \nabla p \right)$$

Take the spatial Fourier Transform

$$\frac{\partial \hat{\Theta}(\mathbf{k}, t + \tau)}{\partial \tau} - i \mathbf{k} \cdot \mathbf{v} \hat{\Theta}(\mathbf{k}, t + \tau) =$$

$$- k^2 \alpha \hat{\Theta}(\mathbf{k}, t + \tau) - \frac{p_0 \gamma \delta \omega}{2 \rho_0 \hat{C}_p} e^{-i \mathbf{k} \cdot (\mathbf{v} + \mathbf{v}_s)(t + \tau)}$$

The correlation function for the temperature fluctuations

$$C_{TT}(\mathbf{k}, \tau) \equiv \hat{\Theta}(\mathbf{k}, t) \hat{\Theta}(\mathbf{k}, t + \tau)$$

$$\frac{\partial C_{TT}(\mathbf{k}, \tau)}{\partial \tau} - i \mathbf{k} \cdot \mathbf{v} C_{TT}(\mathbf{k}, \tau) = -k^2 \alpha C_{TT}(\mathbf{k}, \tau)$$

$$C_{TT}(\mathbf{k}, \tau) = C_{TT}(\mathbf{k}, 0) \exp[i \mathbf{k} \cdot \mathbf{v} \tau] \exp[- k^2 \alpha \tau]$$

If we assume sound waves do not attenuate over scale of measurement,

$$C_{PP}(\tau) = \exp[i \mathbf{k} \cdot (\mathbf{v} \pm \mathbf{v}_s) \tau]$$

Overall

$$\hat{R}_{SS}(\mathbf{k}, \tau) = \varepsilon_1^2 \exp[- i \mathbf{k} \cdot \bar{\mathbf{v}} \tau] \exp[- k^2 \alpha \tau] + \varepsilon_2^2 \exp[- i \mathbf{k} \cdot (\bar{\mathbf{v}} \pm \mathbf{v}_s) \tau]$$

Note the thermal decay term.

For air, $\alpha \approx 0.1 \text{ cm}^2 \text{ sec}^{-1}$. If $k \approx 10^4 \text{ cm}^{-1}$,
the decay time is ca. 0.1 microseconds!

Means that practical system will need small
scattering angle.

Doppler Velocimeter

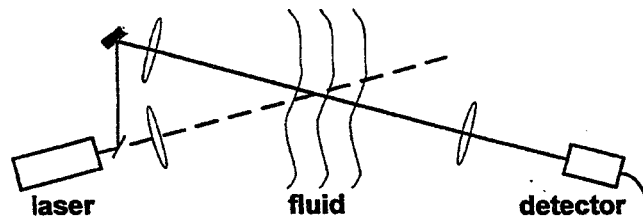

The code of the system is a spatial wave packet.

**The system has poor spatial resolution along the
optical axis.**

A time-of-flight configuration

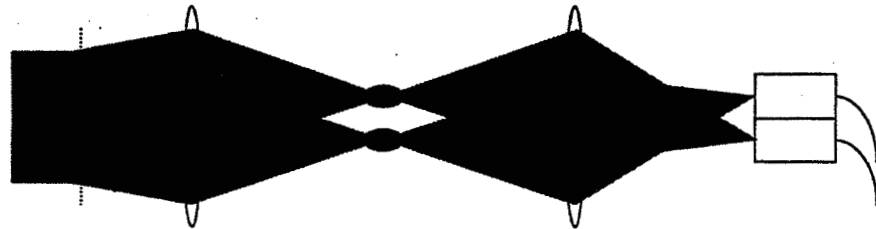

The code is given by two displaced peaks.

Has very good resolution along the optical axis - but
does not work in the present case!

The hybrid system

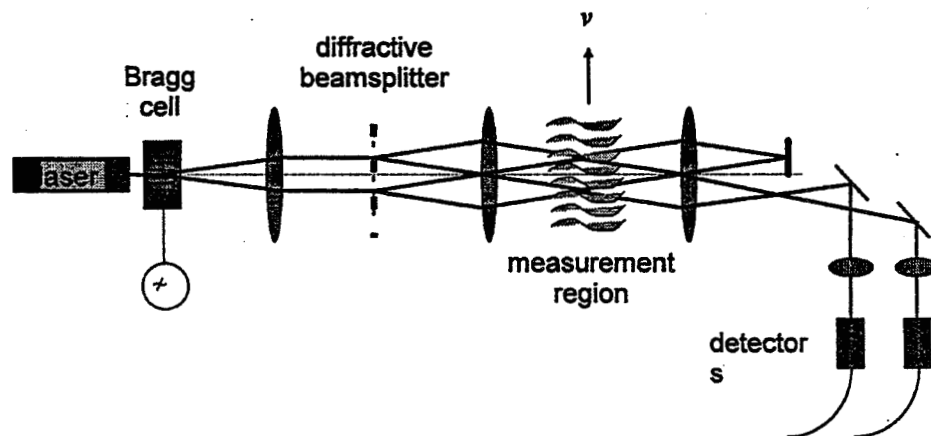

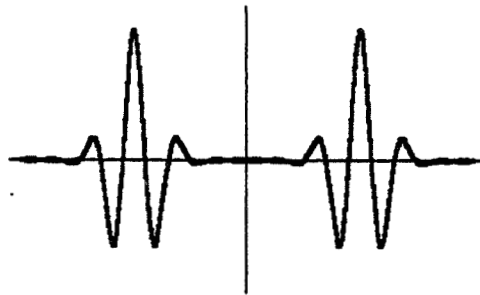

The intensity distribution (deviation from the mean) as seen by the detectors of a hybrid laser anemometer, which defines the *code* of the system.

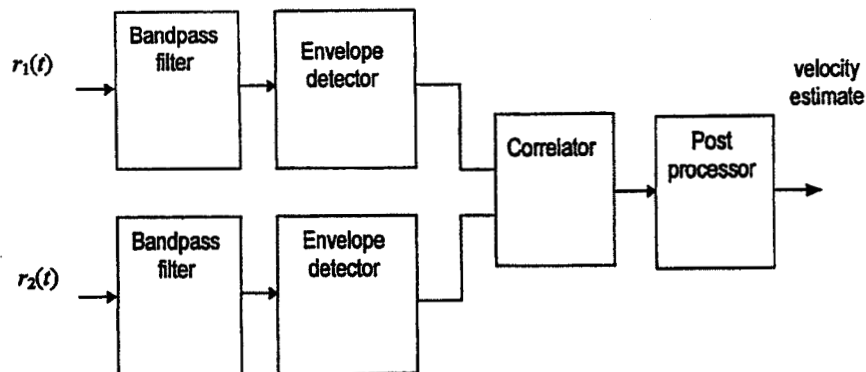

Cross Correlation

$$R_{12}(\tau) = \iint \hat{F}(k-k') \hat{F}(k-k'') e^{-i\mathbf{k}'' \cdot \mathbf{l}} \langle \hat{S}(k', t) \hat{S}(k'', t + \tau) \rangle dk' dk''$$

For turbulent flow

$${}^{(2)}R_c(\tau) = \int_{\text{all } \nu} {}^{(2)}R_{12}(\tau, \nu) dP(\nu)$$

Envelope detection is used, so

$$R(\tau) = R_{12}^2(0) + 2 R_{12}^2(\tau)$$

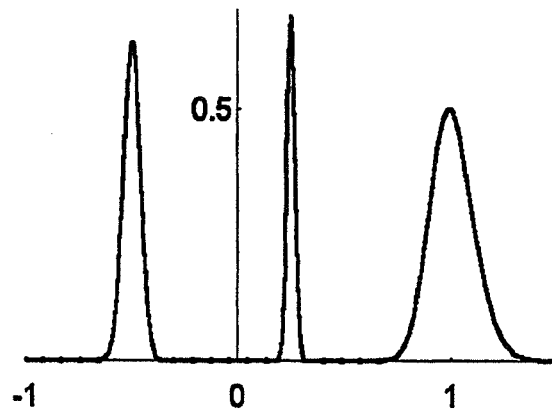

Correlation function assuming both propagating and nonpropagating fluctuations of the same initial power. The s.d. of the convection velocity is 0.1. The Mach # is 0.33.

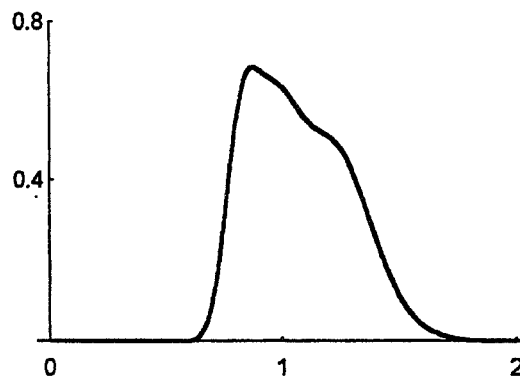

Mach # of 4.

Conclusion + current state

- **Mean velocity + turbulence from peak + width of crosscorrelation if low turbulence intensity and well separated velocities**
- **Curve fitting is necessary in general**
- **Simplest if propagating fluctuations are negligible**
- **Optics of new system is operating and signals observed**

54-09
29376

RAYLEIGH SCATTERING MEASUREMENTS IN NASA LANGLEY'S HYPERSONIC FACILITIES

Richard R. Antcliff
NASA Langley Research Center
Hampton, Virginia

10P.

032656

The "Real" Authors

Behrooz Shirinzadeh
Jeff Balla
Merv Hillard

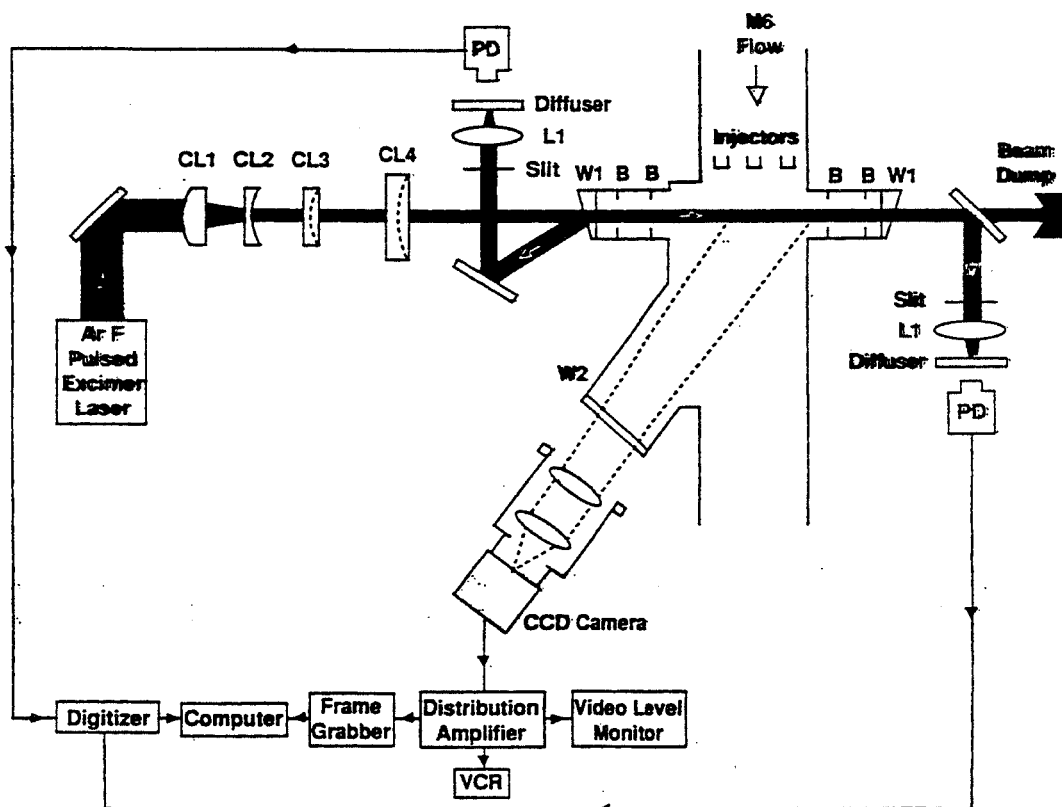

ADVANCED 2-D LASER DIAGNOSTICS

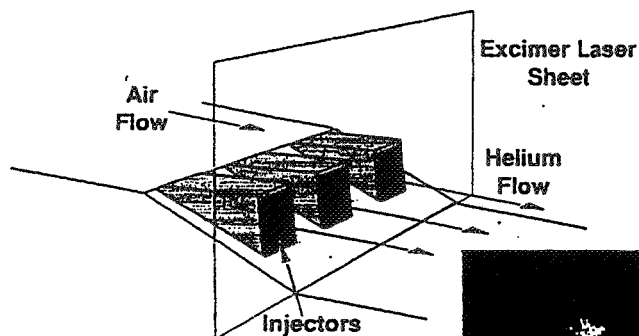

Rayleigh Scattering
Supersonic Mixing Study

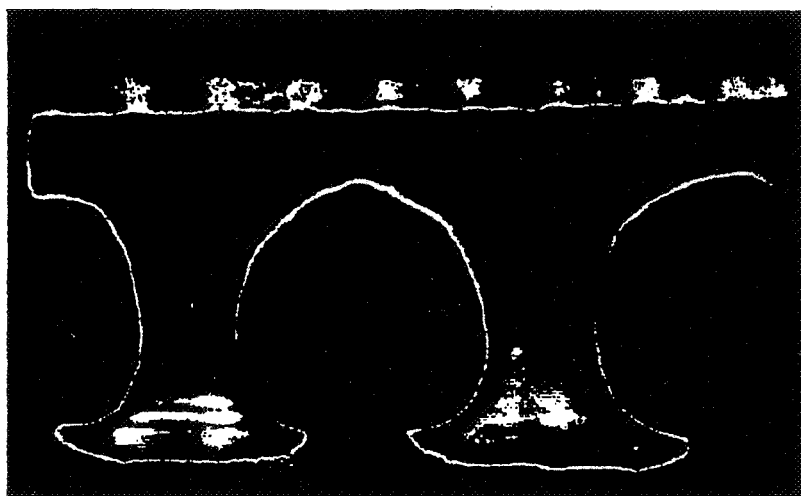

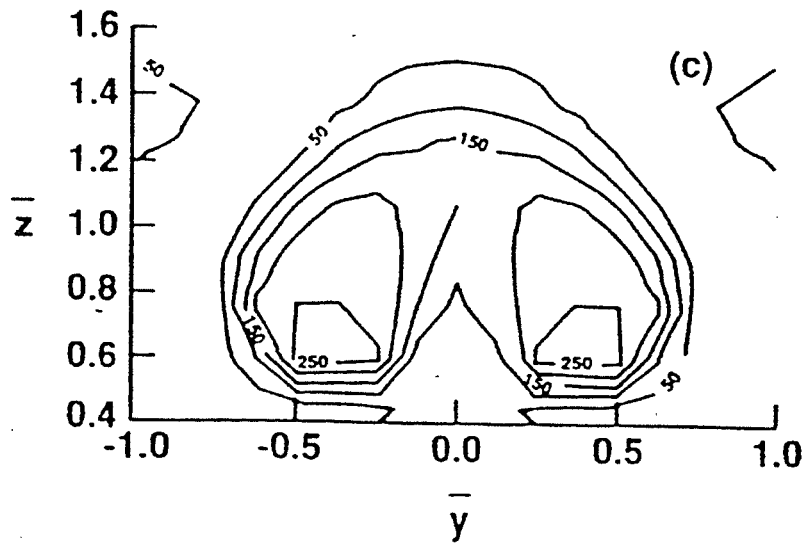
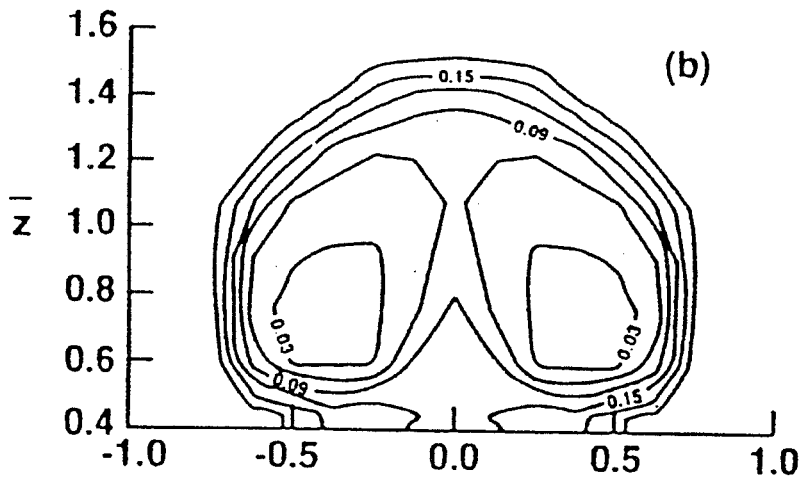
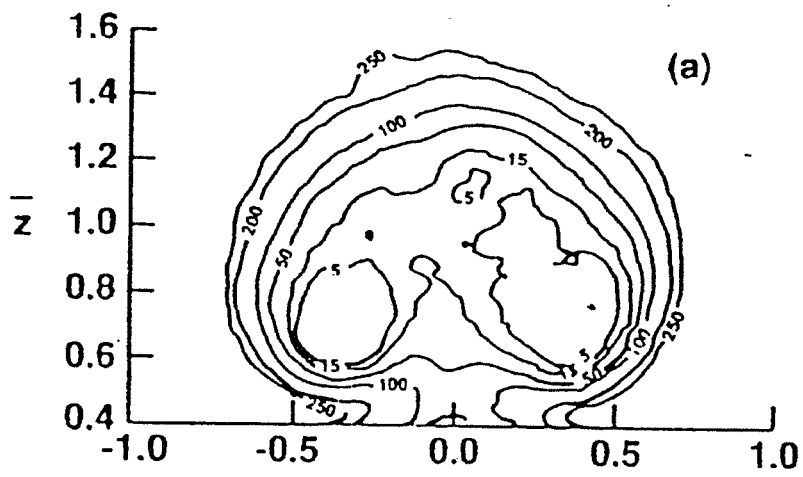

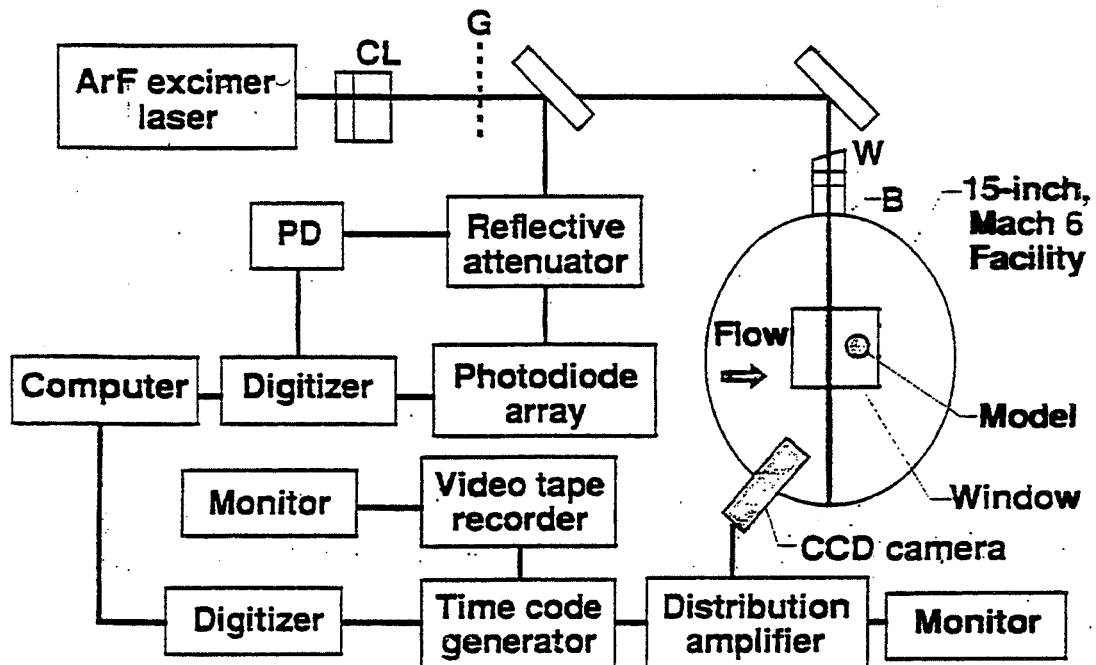
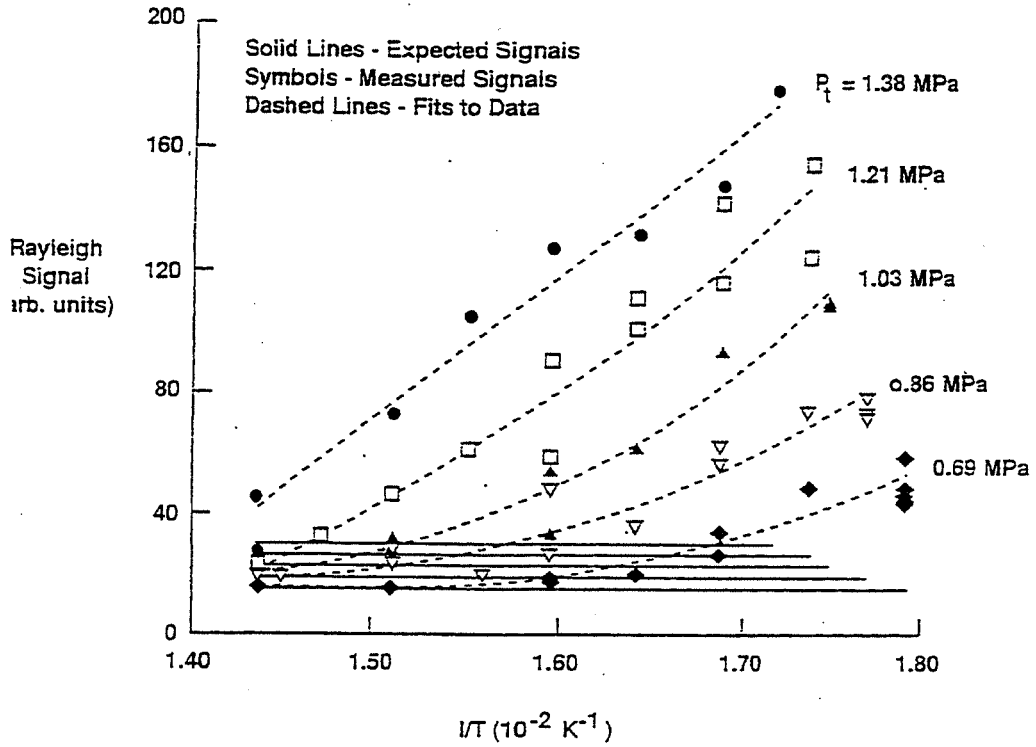

Laser

- ArF excimer
- 193nm
- 15Hz
- narrowband
- 120mJ/pulse

Facility

- 15" test section
- Mach 6 air
- variable temperature up to 700K
- 0.35-2.07 Mpa (50-300psia)

Operating Conditions

- 672K
- 1.38 Mpa (200psia)

Model

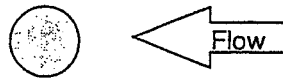

- cylinder
- 38.1 mm diameter
- 15.25 cm length

Array and Camera Profiles

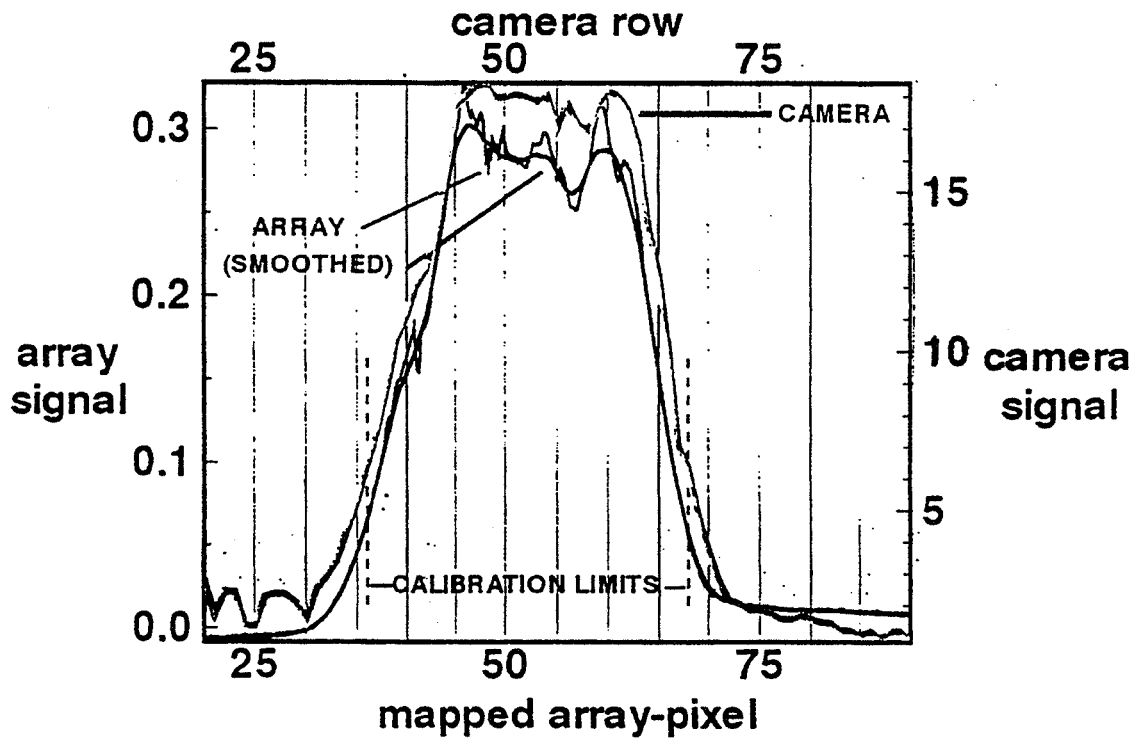

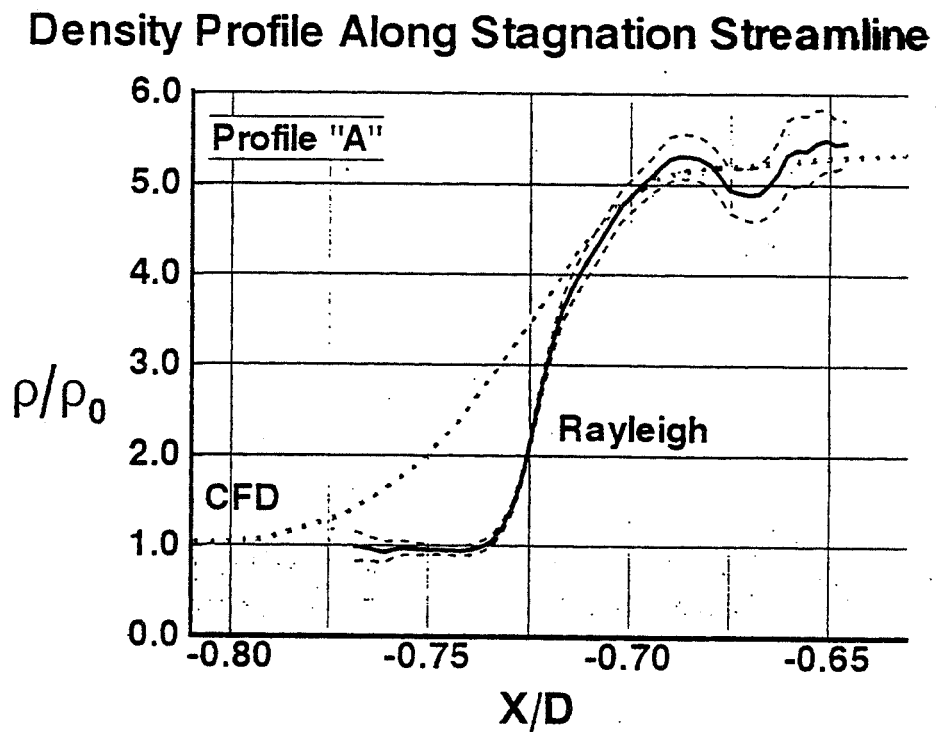
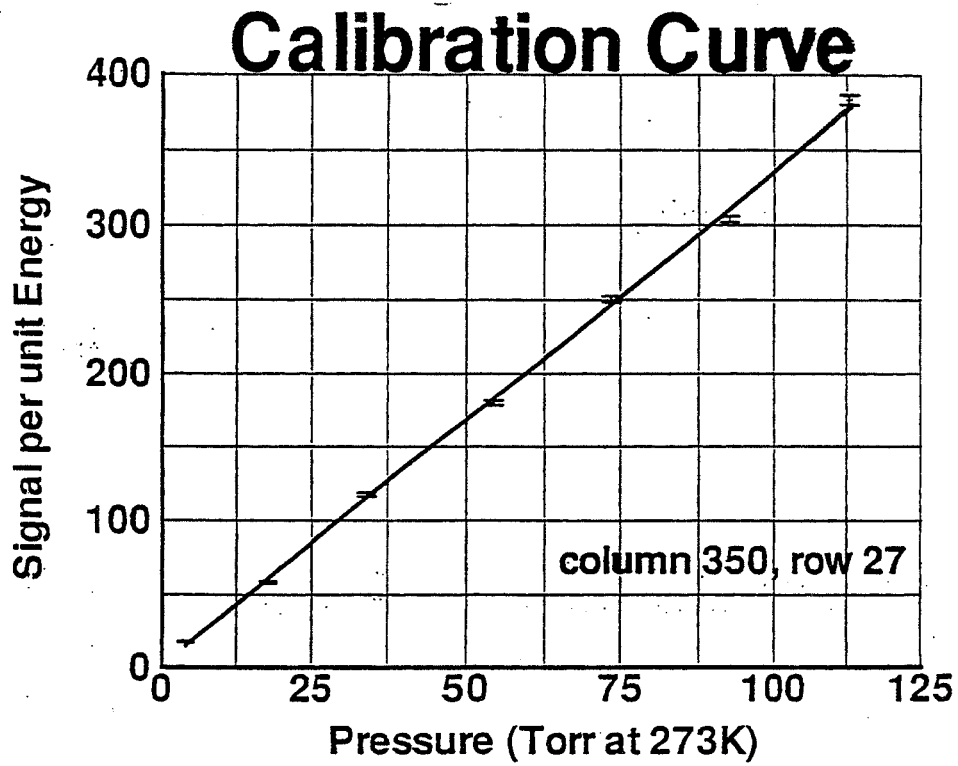

Density Profile Across Cylinder Bow Shock

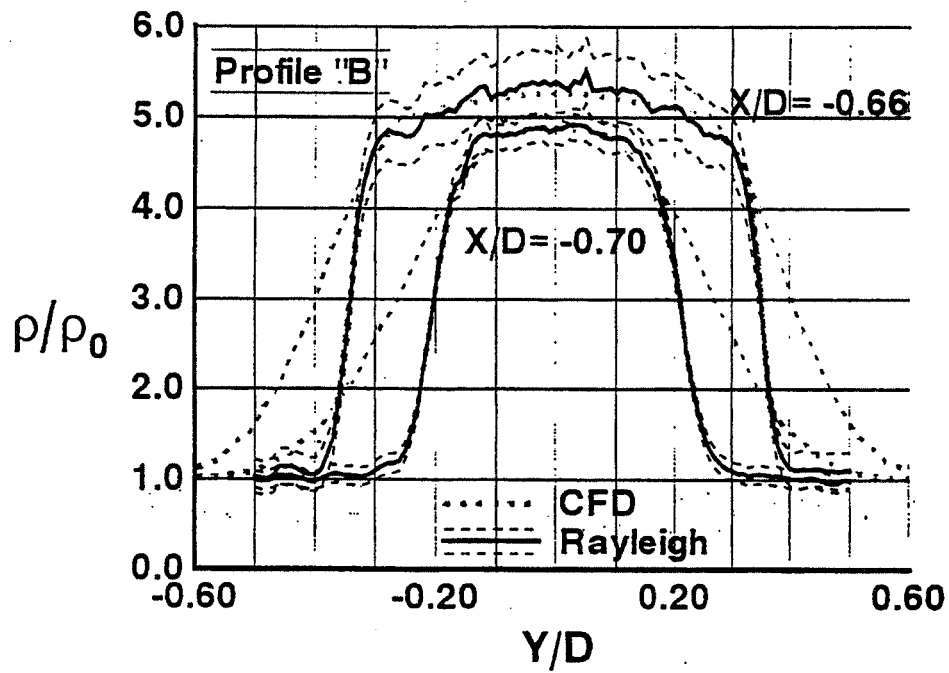

Density Profile Across Cylinder Wake

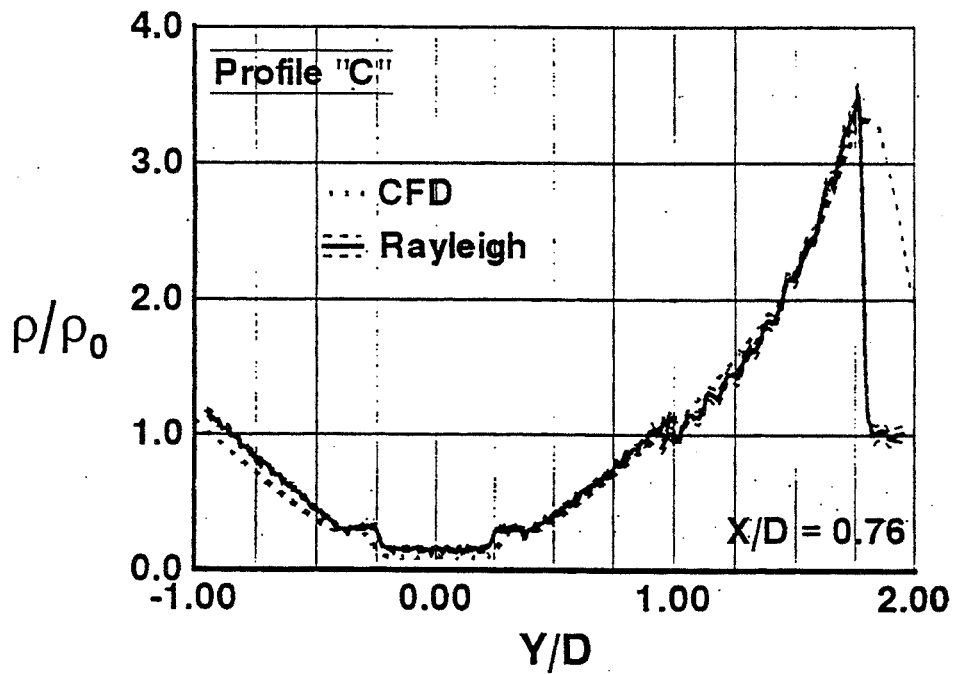

Conclusions

- 1) The capability of the Rayleigh scattering technique for quantitative density measurements in a Mach 6 flow has been demonstrated.
- 2) The densities deduced from the Rayleigh measurements performed on a cylindrical model are in general agreement with the CFD calculations..
- 3) Further improvements in the accuracy of the measurement may be possible through an increase in the signal-to-noise ratio and removal of the systematic errors.

Future Plans

- 1) Remove the systematic errors from the data by better design of the apparatus.
- 2) Test the feasibility of using the Rayleigh scattering technique at 248 nm to improve the signal-to-noise ratio.
- 3) Repeat the measurements on the cylindrical model in the 15-inch, Mach 6 high temperature facility to obtain a complete data set in the wake region for comparison to the CFD model calculations.
- 4) Extend the capabilities to different model flow fields.

References

- "Quantitative Density Measurements in a Mach 6 Flow Field Using The Rayleigh Scattering Technique," B. Shirinzadeh, R.J. Balla, M. E. Hillard, presented at the 16th International Congress on Instrumentation in Aerospace Simulation Facilities, Wright Patterson Air Force Base, July 18-21, 1995.
- "Planar Rayleigh scattering results in helium-air mixing experiments in a Mach-6 wind tunnel," B. Shirinzadeh, M.E. Hillard, R.J. Balla, I.A. Waitz, J.B. Anders, R.J. Exton, *Applied Optics* 31(30), 20 October, 1992.
- "Study of Rayleigh Scattering for Visualization of Helium-Air Mixing at Mach 6", B. Shirinzadeh, R.J. Balla, M.E. Hillard, J.B. Anders, R. J. Exton, I.A. Waitz, proceedings of the International Congress on Instrumentation in Aerospace Simulation Facilities, Rockville, MD, October 27-31, 1991.
- "Study of Cluster Formation and its effects on Rayleigh and Raman scattering measurements in a Mach 6 wind tunnel," B. Shirinzadeh, M.E. Hillard, A. B. Blair, R.J. Exton, presented at the AIAA 22nd Fluid Dynamics, Plasma Dynamics & Lasers Conference, AIAA 91-1496, 24-26 June, 1991.
- "Condensation Effects on Rayleigh Scattering Measurements in a Supersonic Wind Tunnel," B. Shirinzadeh, M.E. Hillard, R.J. Exton, *AIAA Journal* 29(2), pp. 242-246, February 1991.
- "Quantitative Density Measurements in a Mach 6 Flow Field Using The Rayleigh Scattering Technique," B. Shirinzadeh, R.J. Balla, M. E. Hillard, presented at the 16th International Congress on Instrumentation in Aerospace Simulation Facilities, Wright Patterson Air Force Base, July 18-21, 1995.
- "Planar Rayleigh scattering results in helium-air mixing experiments in a Mach-6 wind tunnel," B. Shirinzadeh, M.E. Hillard, R.J. Balla, I.A. Waitz, J.B. Anders, R.J. Exton, *Applied Optics* 31(30), 20 October, 1992.
- "Study of Rayleigh Scattering for Visualization of Helium-Air Mixing at Mach 6", B. Shirinzadeh, R.J. Balla, M.E. Hillard, J.B. Anders, R. J. Exton, I.A. Waitz, proceedings of the International Congress on Instrumentation in Aerospace Simulation Facilities, Rockville, MD, October 27-31, 1991.
- "Study of Cluster Formation and its effects on Rayleigh and Raman scattering measurements in a Mach 6 wind tunnel," B. Shirinzadeh, M.E. Hillard, A. B. Blair, R.J. Exton, presented at the AIAA 22nd Fluid Dynamics, Plasma Dynamics & Lasers Conference, AIAA 91-1496, 24-26 June, 1991.
- "Condensation Effects on Rayleigh Scattering Measurements in a Supersonic Wind Tunnel," B. Shirinzadeh, M.E. Hillard, R.J. Exton, *AIAA Journal* 29(2), pp. 242-246, February 1991.

55-34
79377

INVESTIGATION OF CONDENSATION/CLUSTERING EFFECTS ON RAYLEIGH SCATTERING
MEASUREMENTS IN A HYPERSONIC WIND TUNNEL

Charles Tyler
Wright-Patterson Air Force Base
Wright-Patterson Air Force Base, Ohio

030658
12P.

ABSTRACT

Rayleigh scattering, a nonintrusive measurement technique for the measurement of density in a hypersonic wind tunnel, is currently under investigation at Wright Laboratory's Mach 6 wind tunnel. Several adverse effects, i.e. extraneous scatter off walls and windows, hinder Rayleigh scattering measurements. Condensation and clustering of flow constituents also present formidable obstacles to overcome. Overcoming some of these difficulties, measurements have been achieved while the Mach 6 test section was pumped down to a vacuum, as well as for actual tunnel operation for various stagnation pressures at fixed stagnation temperatures. Stagnation pressures ranged from 0.69MPa to 6.9MPa at fixed stagnation temperatures of 511, 556 and 611K. Rayleigh scatter results show signal levels much higher than expected for molecular scattering in the wind tunnel. Even with higher-than-expected signals, scattering measurements have been made in the flowfield of a 8-degree half-angle blunt nose cone with a nose radius of 1.5 cm.

INTRODUCTION

Extraneous scattering off tunnel walls and windows and condensation effects have always caused problems with using the Rayleigh scattering technique in hypersonic wind tunnels. Eliminating surface scatter background noise overcomes only one of the adverse effects troubling the Rayleigh scatter technique. Condensation and clustering of the flow constituents has been found to hamper Rayleigh scatter measurements^{1,2}. The condensation of air in hypersonic wind tunnels takes place at relatively low supersaturation ratios. This is possibly condensation taking place onto nuclei of water and/or carbon dioxide, which exist in the air as minor components, and which condense well before the saturation of nitrogen or oxygen is reached. The condensation of the water and/or carbon dioxide does not seriously affect the stream properties because of the small percentage in which they exist. However, a large number of nuclei are formed in the condensation of these minor components, which then act as nuclei for oxygen and nitrogen condensation at low degrees of supersaturation of these principal components. Throughout the past, a lot of research regarding condensation in supercooled hypersonic flow has been performed^{3,4,5,6}. Condensation/clustering biases will be discussed in a later section.

EQUIPMENT AND FACILITY DISCUSSION

The Rayleigh scattering measurement system located at Wright Laboratory's Mach 6 wind tunnel is shown in figures 1 and 2. A standard Nd:YAG pulsed laser, producing a frequency doubled 532nm beam, pumps two oscillator-amplifier, tunable dye lasers. However, only one dye laser is required for the Rayleigh scatter system so the output from one of the dye lasers is blocked. The unblocked dye laser is tuned such that the wavelength of the exit beam is 613nm. This exit beam is then frequency doubled using a BBO doubling crystal resulting in a beam with a wavelength of ~306.5nm. As a result of the doubling process and optical set-up the red beam, 613nm, and the UV beam, 306.5nm, are collinear.

The collinear beams pass through a gas reference cell containing a gas at a known pressure and temperature. The gas in the reference cell is comparable to the gas being measured in the wind tunnel. For this experiment the gas is standard air. The reference cell provides a means of eliminating pulse-to-pulse laser power fluctuations. Two photomultiplier tubes (PMT), one for the red beam the other for the UV beam, are mounted within the reference cell. The PMTs collect scattered light; converting it into a signals, referred to as "reference" signals. The reference signals are used to normalize the actual signals, referred to as "sample" signals, in the wind tunnel's test section from small variations in the relative laser pulse energy.

After exiting the reference cell the laser beams are directed into the test section through a fused-silica window. Two 90-degree turning prisms steer the beams such that they enter the window on one side of the test section and strike the wall on the other side.

A light collection system consisting of a 30cm focal length planoconvex lens, bandpass filters and two PMTs, red and UV respectively, is mounted on a three-dimensional traverse outside the test section. The angle of observation is perpendicular to the direction of the incident light. The reference and sample signals are collected by a data acquisition computer system. The acquisition computer system consists of gated integrators, A/D converter and a 286 IBM-compatible computer.

The Wright Laboratory's Mach 6 wind tunnel, see figure 3, is a blowdown tunnel which uses dried, compressed air. The air is heated to 500-611K by a heater bed of stainless steel balls prior to entering the stagnation chamber. The tunnel has an axis-symmetric, 31.36cm diameter nozzle contoured to produce an uniform flow which has a calibrated centerline Mach number of 5.76. The tunnel was operated over a range of stagnation pressures, 0.69MPa - 6.9MPa in increments of 0.69MPa, at fixed stagnation temperatures, 511, 556 and 611K. For stagnation pressures less than 4.14MPa the air exhausted from the tunnel is directed into a 2,831 m³ vacuum sphere, see figure 4; otherwise the tunnel is exhausted to atmosphere.

RESULTS

The main assumption of the Rayleigh scattering measurement system at Wright Laboratory is that Rayleigh coefficients are proportional to air density. In other words, there is a linear relationship between the air density and the intensity of scattered light. With this understanding, intensity measurements were taken in a no flow situation at atmospheric and very low pressure conditions; pressures and temperatures were obtained from static probes within the test section. Now, since intensities at two known density conditions were obtained, a line can be drawn which shows the relation between density and intensity. By using this relation the surface scatter background noise can be determined and eliminated,

$$\text{slope} = M = \frac{(I_2 - I_1)}{(\rho_2 - \rho_1)} \quad (1)$$

$$\text{background scatter} = b = I_1 - M*\rho_1 \quad (2)$$

It may be noted that the UV light makes for better Rayleigh scatter measurements than the red light, which follows the theory as expected.

To better see the linear relation between density and intensity of scattered light the test section was slowly pumped down to a very low pressure. Rayleigh scattering measurements were performed during the evacuation process, tracking the density of the air in the test section to its lower limit of .019 kg/m³. These tracking measurements are shown in figure 5.

Since the Rayleigh scattering measurement system appeared to track the tunnel density readings well, the test section was quickly evacuated to a low pressure. When the test section is quickly evacuated the temperature decreases both suddenly and drastically. Water vapor present in the air spontaneously condenses and fills the test section with condensation particles. Condensed water droplets cause both PMTs, red and UV wavelengths respectively, to reach saturated levels, as seen in figure 6. When the tunnel is started and operating at hypersonic flow conditions, neither PMT reach saturation conditions. This observation, along with studies of intensity measurements obtained through a polarization filter rotated through various angles 0, 45 and 90 degrees, lead to the belief that although condensation of carbon dioxide and possible clustering of oxygen and nitrogen occur, large dust particles are not present during tunnel operation.

Although large dust particles apparently are absent from the flow during tunnel operation, higher-than-expected intensity signals were acquired when the tunnel was operating at the aforementioned conditions. As shown in figure 7, the intensity signals diverge from the expected measurements quite dramatically for the lower stagnation temperature. Even at the lowest stagnation

temperature, 511K, and the highest stagnation pressure, 6.9MPa, condensation of the principal components of air, nitrogen and oxygen, should not occur. However, carbon dioxide, which exists in air as a minor component, condenses well before the saturation of nitrogen or oxygen, see figure 8. The condensation of carbon dioxide does not seriously affect the stream properties because of the small percentage in which they exist. However, a large number of nuclei are formed in the condensation of carbon dioxide, which then may act as nuclei for oxygen and nitrogen condensation at low degrees of supersaturation of these principal components. Even if the condensed carbon dioxide does not cause the primary constituents of air to condense the carbon dioxide condensation particles formed will still foul Rayleigh scattering measurements.

Under the belief that the condensation particles formed by the expansion of the gas from the stagnation chamber are small and may possibly evaporate traveling through a strong shockwave measurements were made on a 8-degree half-angle blunt nose cone shown in figure 8. Measurements were taken on a line perpendicular to the surface of the cone at 12.7 cm back from the tip of the nose. These Rayleigh scattering measurements were compared to computational fluid dynamics results. Close to the surface of the cone the measurements agree while further off the surface and into the freestream it is apparent that the Rayleigh scattering measurements are quite higher-than-expected. Although the quantitative results disagree, it is reassuring to see that qualitatively the two techniques, Rayleigh scattering and computational fluid dynamics, appear similar.

CONCLUSIONS

Extraneous surface scatter background noise and scatter off condensation particles create difficulties in using Rayleigh scatter as a measurement technique in hypersonic flows. Fortunately, the surface scatter background noise has been eliminated by taking scattered intensity readings at two known density conditions, obtaining the linear relation between density and scattered intensity and calculating the level of extraneous background scatter. Condensation particle effects also have been addressed. Since results of the blunt nose cone measurements are qualitatively similar to the computational fluid dynamics results, research into the kinetics of condensation will be pursued.

ACKNOWLEDGEMENTS

The author thanks all the people involved with the Rayleigh scattering instrumentation development test. The author appreciates the effort of work generated by the Mach 6 Facility crew, Joseph Scheuring, Tom Norris and Richard Allen, as well as the pump house crew Mike Green and Dwight Fox. The author would also like to thank the members of the Experimental Diagnostics Branch for all their patience, constant support and helpful suggestions

REFERENCES

1. Shirinzadeh, B., Hillard, M.E. and Exton, R.J., "Condensation Effects on Rayleigh Scattering Measurements in a Supersonic Wind Tunnel," AIAA Journal, Vol 29, pp. 242-246.
2. Shirinzadeh, B., Hillard, M.E., Blair, A.B. and Exton, R.J., "Study of Cluster Formation and its Effects on Rayleigh and Raman Scattering Measurements in a Mach 6 Wind Tunnel," AIAA 91-1496.
3. Durbin, E.J., "Optical Methods Involving Light Scattering for Measuring Size and Concentration of Condensation Particles in Supercooled Hypersonic Flow," NACA Tech Note 2441, 1951.
4. Stever, H.G. and Rathburn, K.C., "Theoretical and Experimental Investigation of Condensation of Air in Hypersonic Wind Tunnels," NACA Tech Note 2559, 1951.
5. Daum, F.L. and Gyarmathy, G., "Air and Nitrogen Condensation in Hypersonic Nozzle Flow," ARL 65-159, Mach 1967.
6. Emmons, H.W., Fundamentals of Gas Dynamics, High Speed Aerodynamics and Jet Propulsion, Vol III, Princeton University Press, Princeton, New Jersey, 1958.

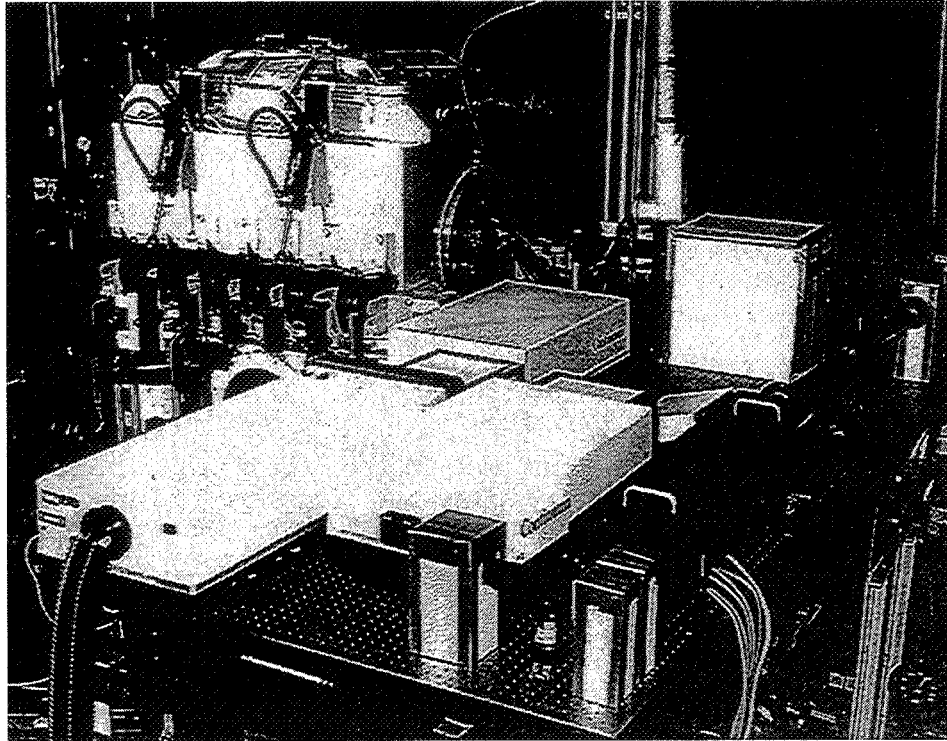

Fig. 1 Rayleigh scattering measurement system.

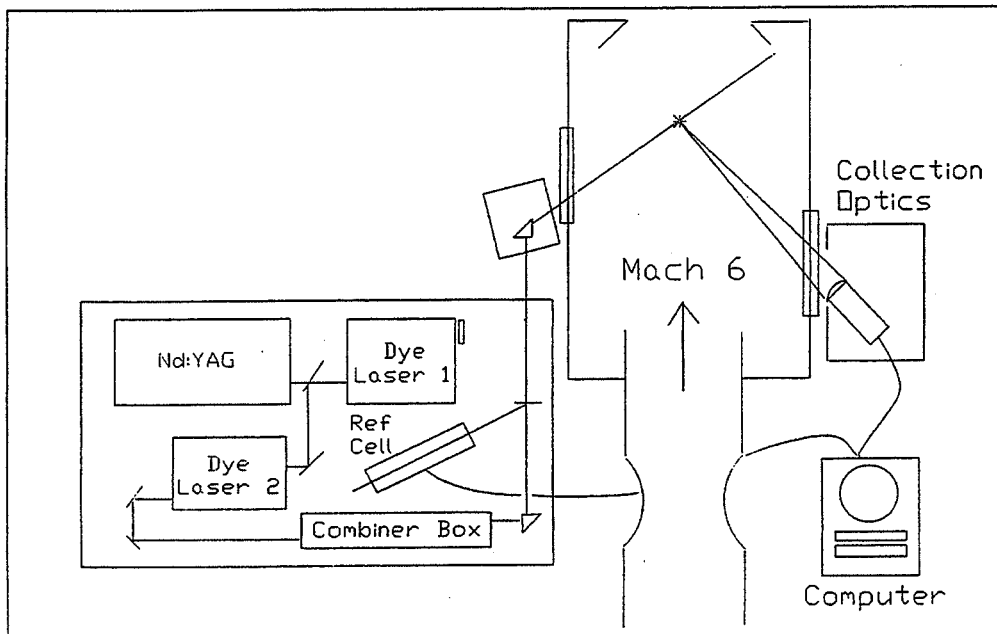

Fig. 2 Schematic of the Rayleigh scattering measurement system.

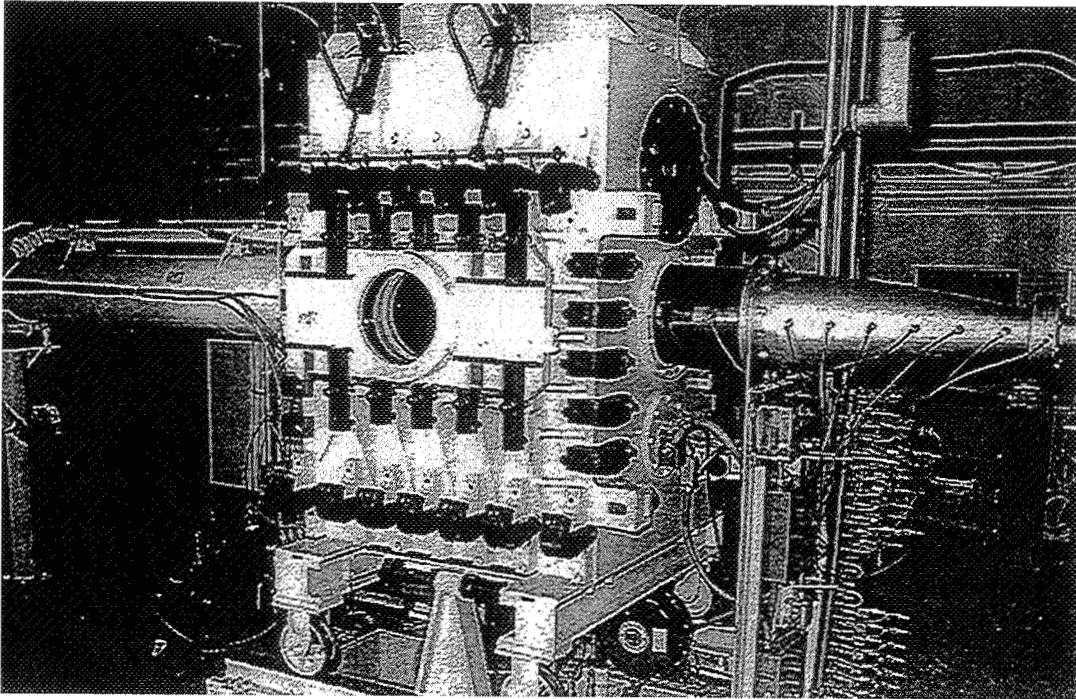

Fig. 3 Wright Laboratory's Mach 6 wind tunnel.

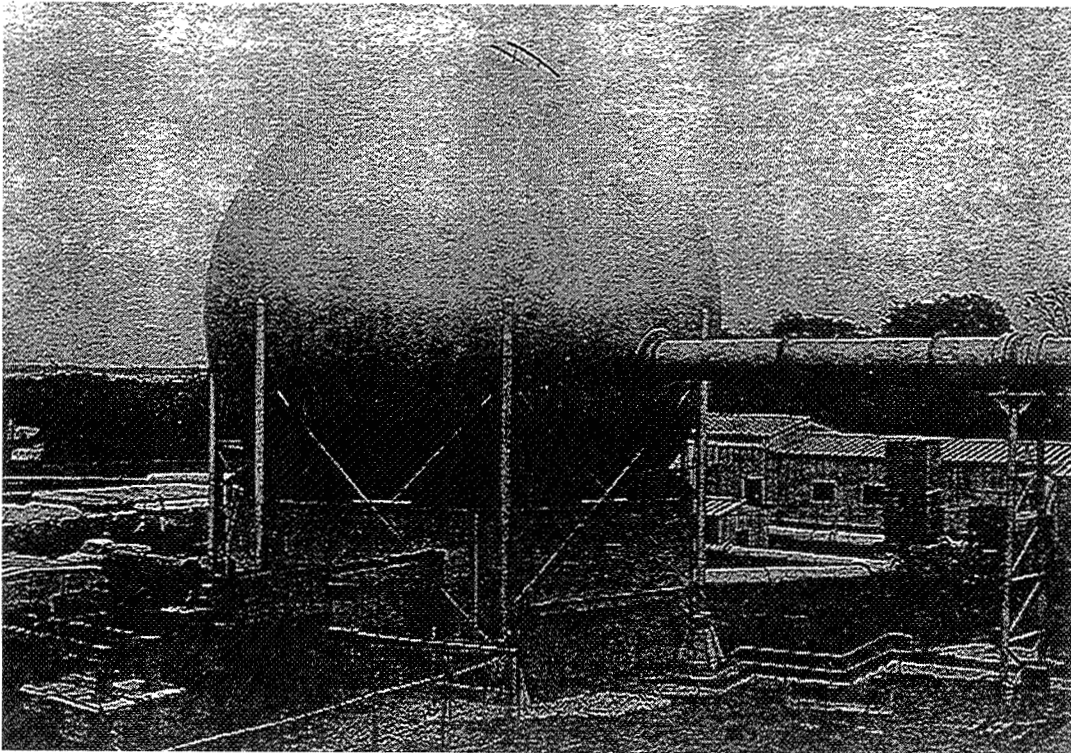

Fig. 4 Facility vacuum sphere.

Tracking of tunnel density readings by the Rayleigh scattering measurement system

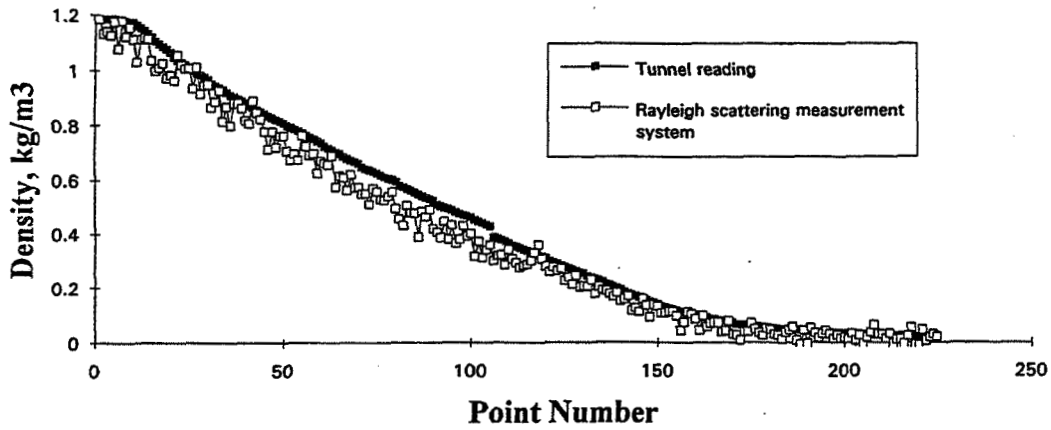

Fig. 5 Density tracking measurements.

Capture of evacuation from atmosphere to vacuum

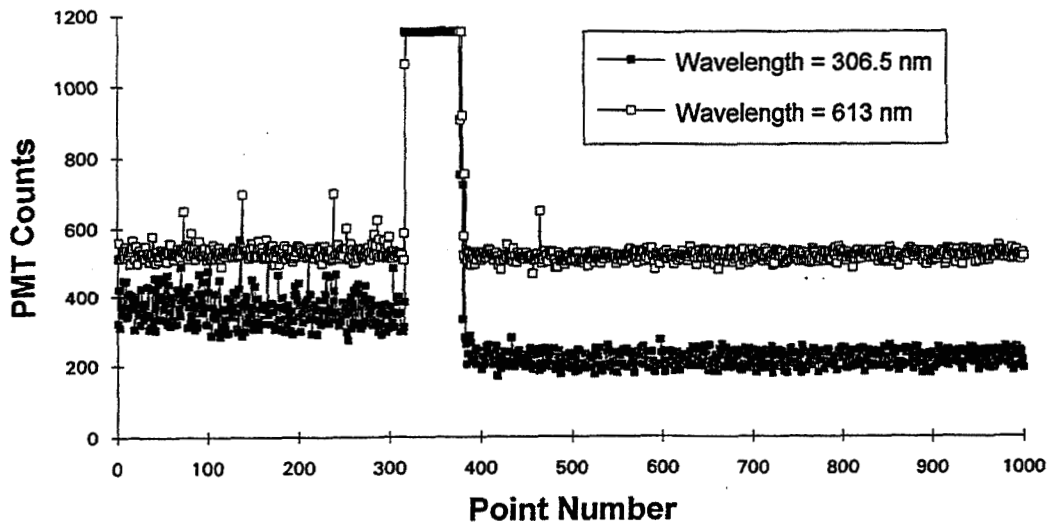

Fig. 6 Capture of test section evacuation.

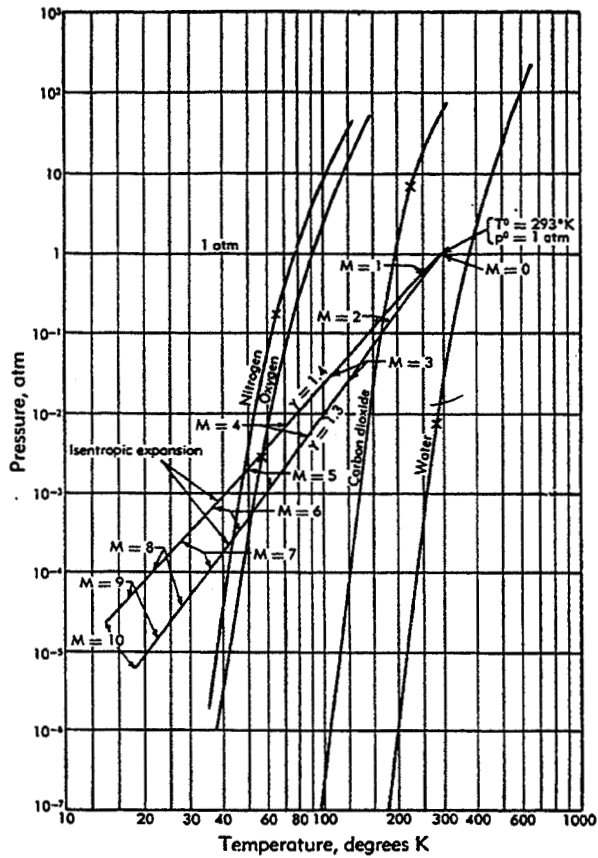

Fig. 7 Saturation lines for water, carbon dioxide, oxygen and nitrogen.

Comparison between calculated densities and measured densities for varying stagnation pressures (.69MPa-6.9MPa)

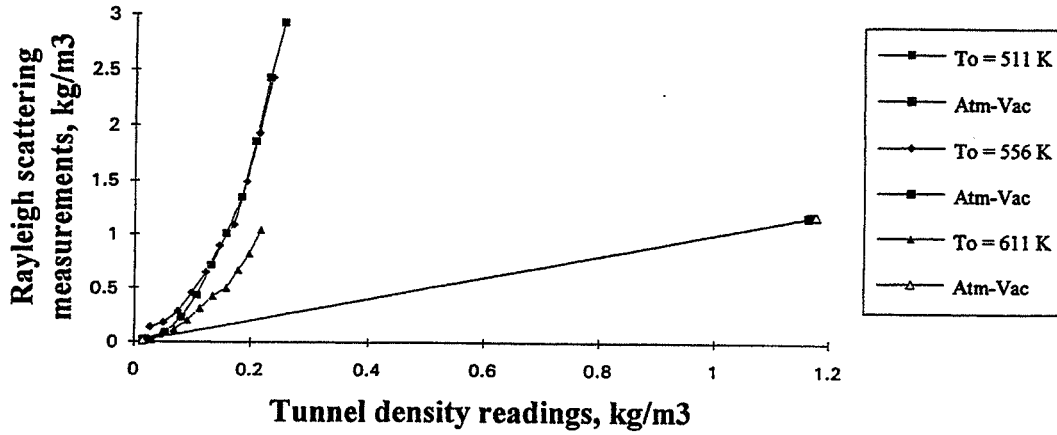

Fig. 8 Rayleigh scattering measurements during empty tunnel runs.

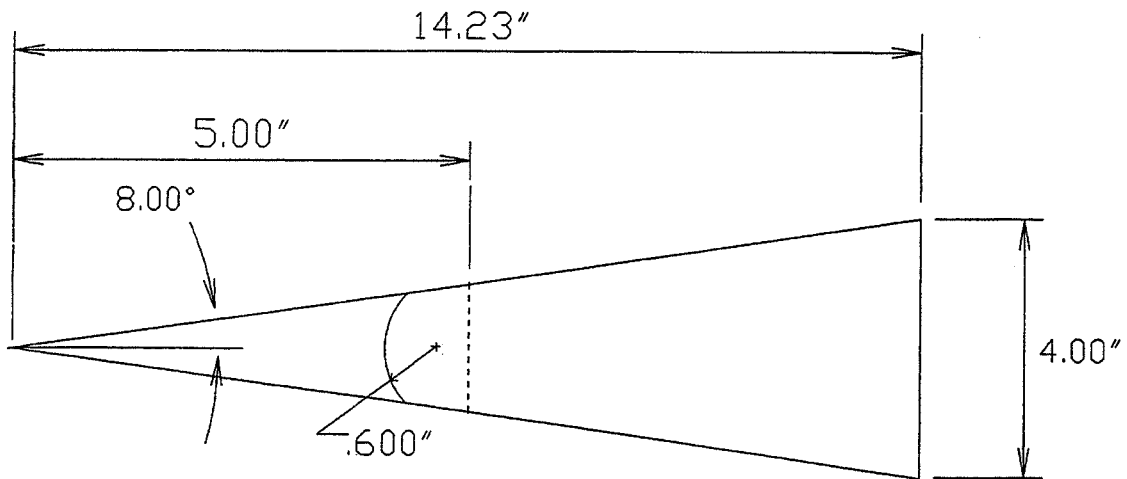

Fig. 9 Schematic of 8-degree half-angle blunt nose cone.

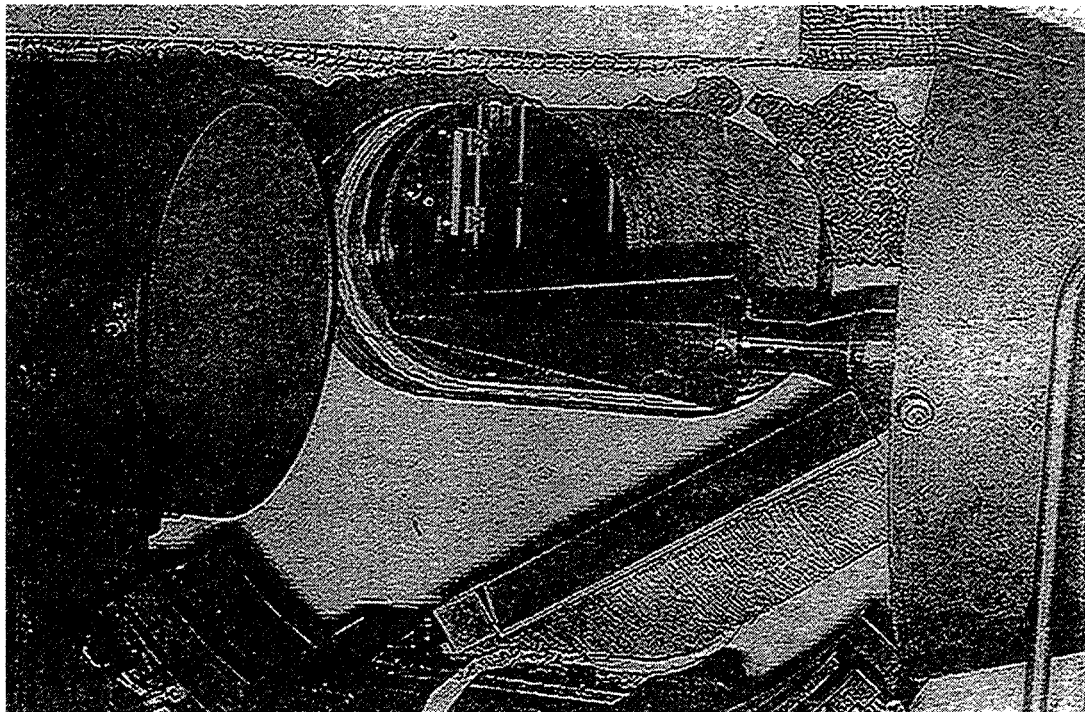

Fig. 10 8-degree half-angle blunt nose cone installed in Mach 6 wind tunnel.

Blunt Nose Cone: 12.7 cm from nose tip, 0 degrees AOA

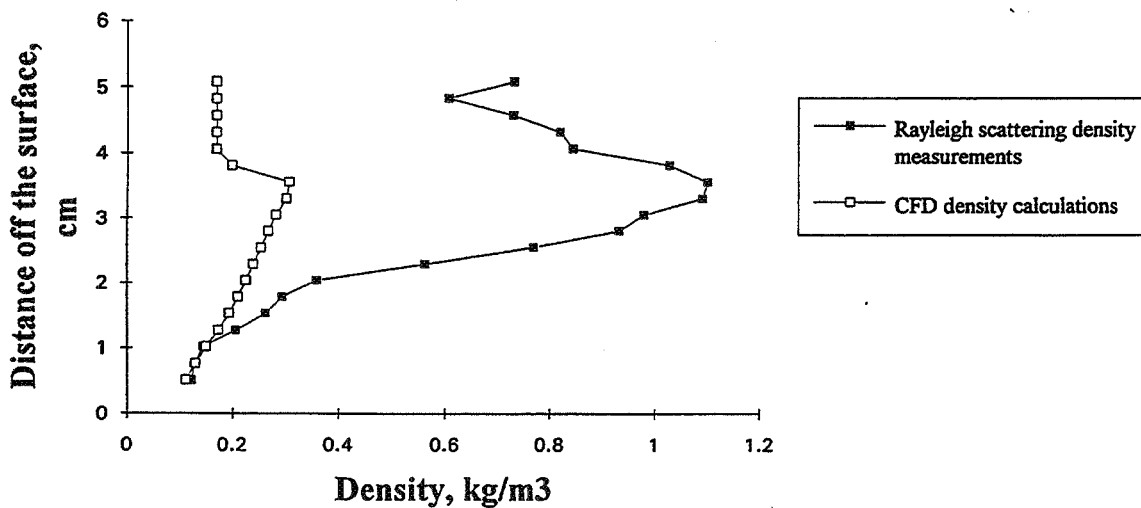

Fig. 11 Rayleigh scattering measurements and computational fluid dynamics comparison.

56-34
79378

DEMONSTRATION AND ANALYSIS OF FILTERED RAYLEIGH SCATTERING FLOW
FIELD DIAGNOSTIC SYSTEM

Joseph N. Forkey, Walter R. Lempert, and Richard B. Miles
Princeton University
Princeton, New Jersey

032659
18p.

Filtered Rayleigh Scattering (FRS) is a diagnostic technique which measures velocity, temperature and pressure by determining Doppler shift, total intensity, and spectral lineshape of laser induced Rayleigh - Brillouin scattering. In the work reported here, this is accomplished by using a narrow linewidth, injection seeded, Nd:YAG laser sheet to induce Rayleigh - Brillouin scattering from gas in a flow. This light is passed through an optical notch filter, and transmitted light is imaged onto an intensified CCD camera. By monitoring the grayscale value at a particular pixel while the laser frequency is tuned, the convolution between the Rayleigh - Brillouin scattering profile and the filter transmission profile is attained. Since the filter profile can be independently measured, it can be deconvolved from the measured signal, yielding the Rayleigh - Brillouin scattering profile. From this profile, flow velocity, temperature, and pressure are determined.

In this presentation, we discuss the construction and characterization of two of the most critical components of the FRS system - the optical notch filter, and a newly developed frequency measurement apparatus - and demonstrate their utility by presenting FRS measurements of velocity, temperature and pressure.

The filter which we have used for these experiments consists of a glass cell 2 inches in diameter, and 4 inches long, with 2 inch diameter sleeves extending 2 inches beyond each of the two windows. A few iodine crystals were placed in the cell before it was evacuated and sealed. The temperature of the cell was monitored and controlled by a RTD element cemented to the cell wall, and heating tape, which covers the entire cell body and sleeves and a temperature feedback controller. The pressure of the cell was set by controlling the temperature of a side arm 'cold tip' which was kept at a lower temperature than the cell body. The side arm was enclosed in a water jacket, and water temperature was controlled by a water bath with a temperature stability of better than ± 0.1 C. For all filter based measurement schemes, accurate characterization and optimization of the filter being used is crucial for obtaining accurate measurements. To this end, we have developed a computer based model which predicts the transmission profile of our molecular iodine based optical notch filter for various cell temperatures and pressures. This model utilizes spectroscopic constants taken from the literature to determine the frequency location of all absorption lines of molecular iodine from the ground X electronic state to the excited B state. All transitions with $v''=0-19$, $J''=0-200$, $v'=0-69$, and $\Delta J=\pm 1$ are considered. Each of these lines is split into 14 or 21 hyperfine lines using published coupling constants for

nuclear electric quadrupole and magnetic hyperfine interactions. A Boltzman distribution is assumed for the population of states; a Gaussian lineshape is assumed for each of the hyperfine absorption lines, and Franck-Condon factors from the literature are used to determine relative line strengths. Details of this model will be discussed. In addition, we have performed a number of experiments to characterize the filter for a number of different operating conditions. These characterizations have been attained with transmission uncertainties of $\pm 0.5\%$, and frequency uncertainties of ± 2 MHz, over a full tuning range greater than 35 GHz. These characterizations, which have been used to validate the model and to analyze FRS data, will also be presented.

Most filter based techniques for measuring velocity, including FRS, rely on the measurement of Doppler shift. Therefore, any systematic error in the measurement of laser frequency, either during an experiment, or during the calibration of the optical notch filter will result in a systematic error in the measured velocity. In this presentation, we will discuss the details of a frequency measuring technique which is capable of continuously measuring laser frequency with a precision of ± 2 MHz. This corresponds to a typical velocity error of ± 1 m/s. This accuracy is achieved by making use of a heterodyne technique which measures laser frequency relative to the iodine absorption line located at 18789 cm^{-1} . This is accomplished by locking the frequency of the doubled laser light (532 nm) from a reference cw, narrow linewidth Nd:YAG laser to the P142(37,0) absorption line of molecular iodine using a first derivative nulling technique. Residual fundamental laser light (1064 nm) from this laser is then overlapped spatially with the 1064 nm light from the laser whose frequency is being measured. This overlap results in a heterodyne beat signal with an oscillation frequency equal to the difference in optical frequencies between the reference laser, and the laser being measured. This heterodyne beat frequency is measured by a high speed photodetector and frequency counter. Details of this technique will be discussed, along with an analysis of the system indicating that measurements with a precision of ± 2 MHz are possible over a range of 80 GHz.

Finally, we demonstrate the use of the equipment discussed above in Filtered Rayleigh Scattering planar measurements of velocity, temperature and density, by presenting measurements made in ambient air conditions and in a Mach 2 jet.

Outline

- Basic Concept
- Filter
 - Model
 - Experimental Characterization
- Laser
 - Frequency Measurement
 - Frequency Tuning
- Experimental Results

Basic Concept

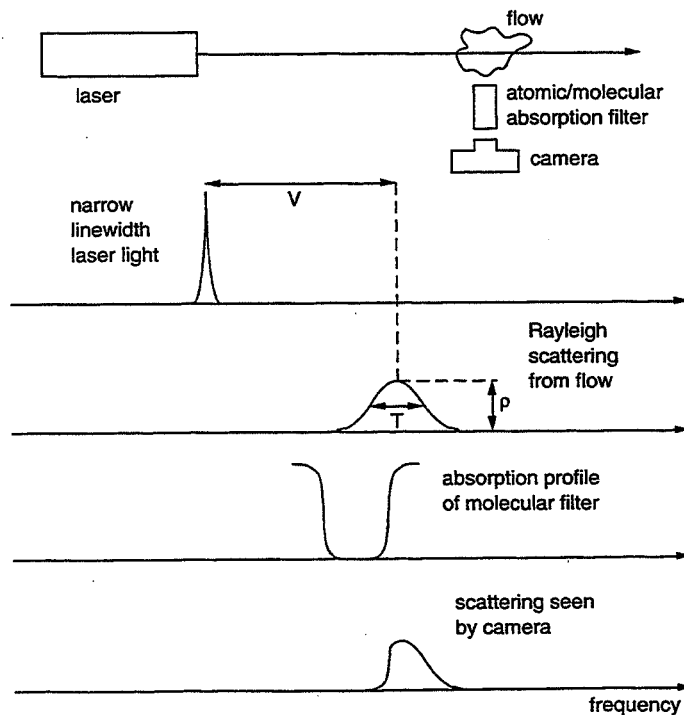

Determination of Flow Parameters via Laser Frequency Tuning

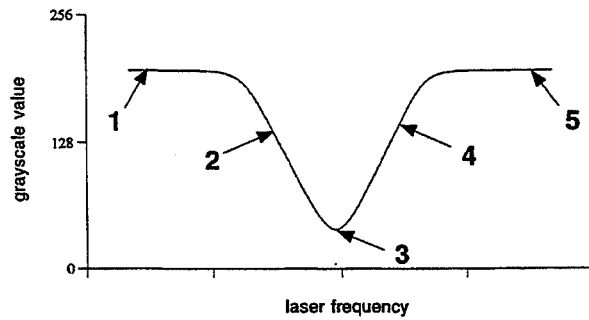
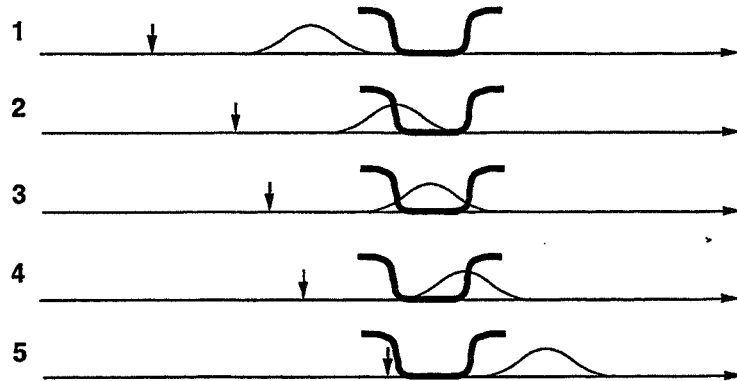

Filter

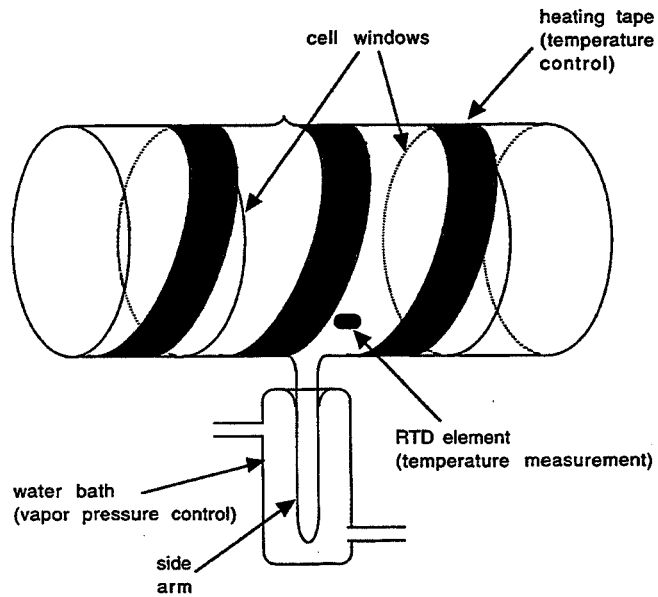

model prediction for 1 torr, 370 K, 10 cm

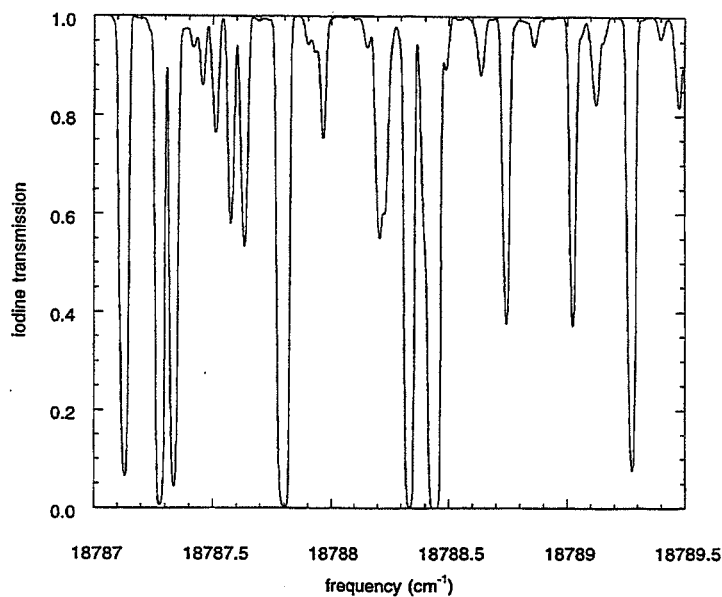

model predictions for various cell temperatures

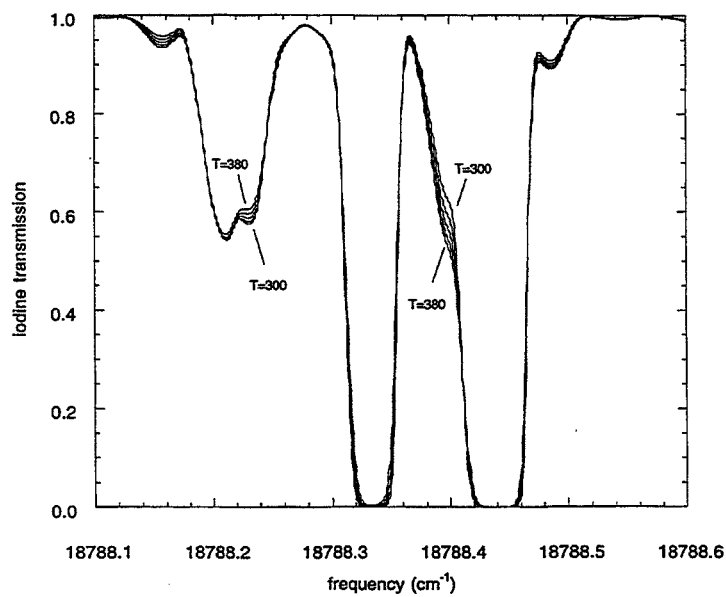

model predictions for various cell pressures

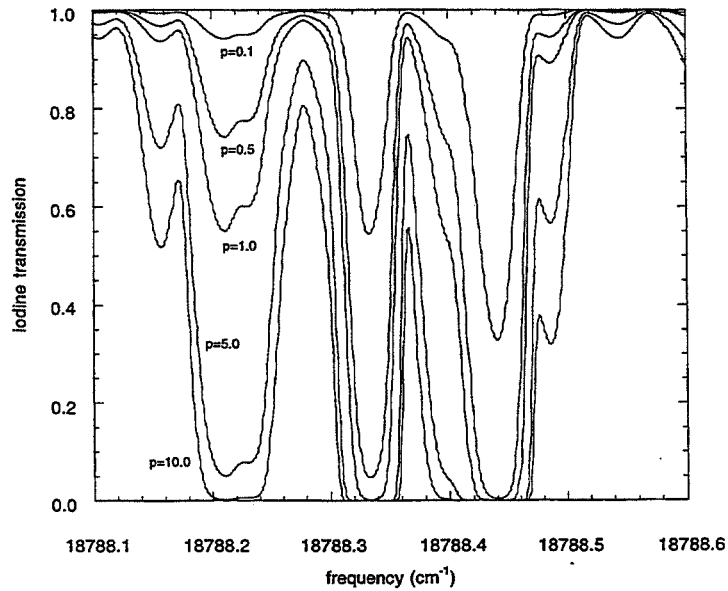

measured filter transmission profile: 353 K, 1.03 torr, 10 cm

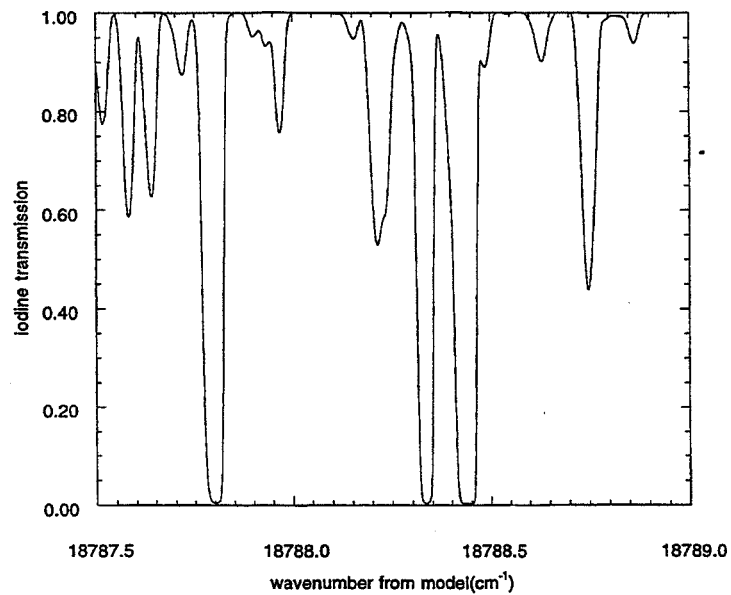

repeatability of transmission measurement

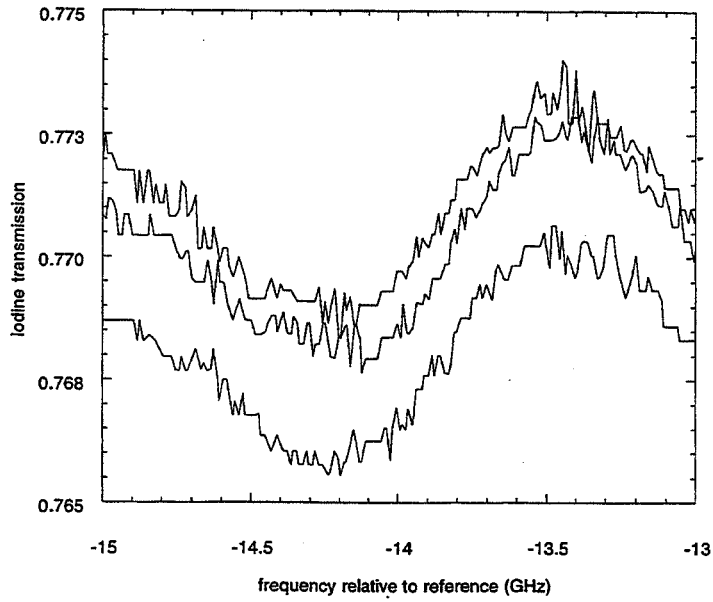

repeatability of frequency measurement

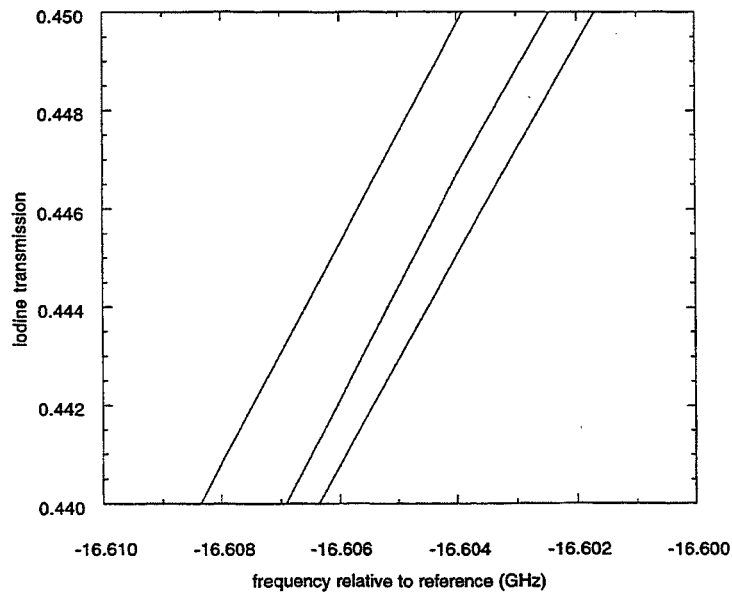

model versus data

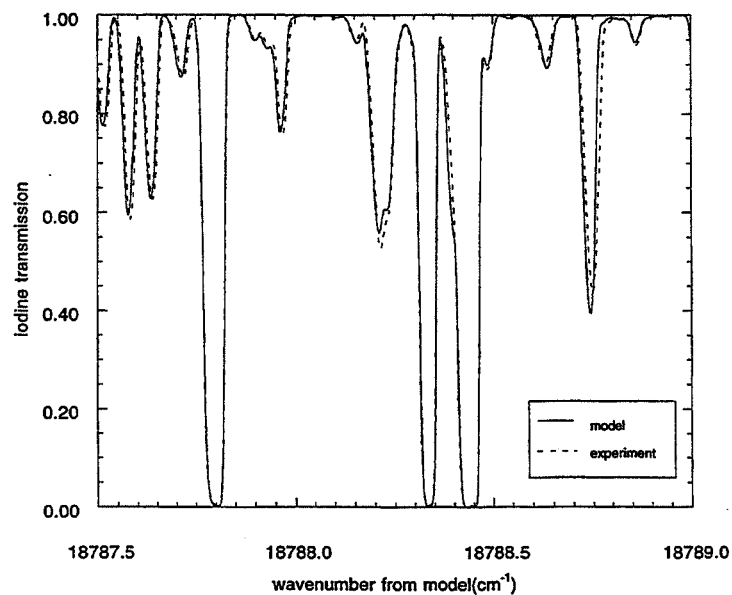

model versus data: 353 K, 0.7 torr, 10 cm

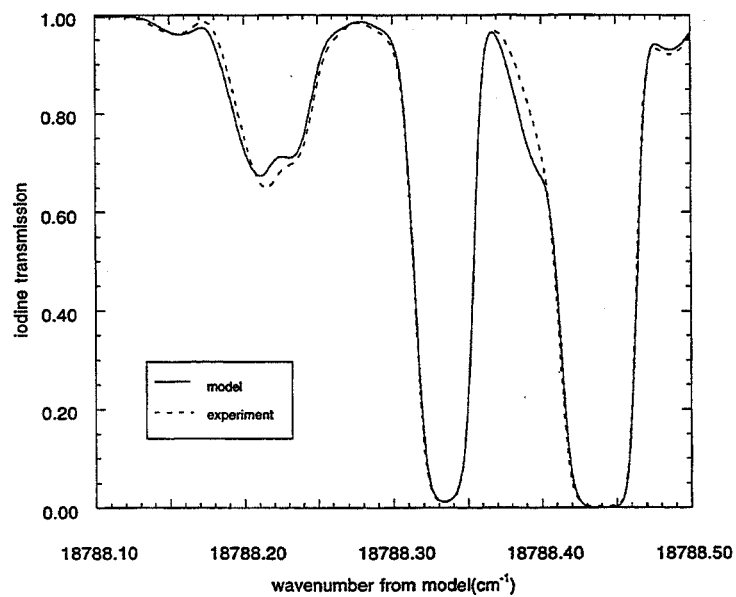

model versus data: 353 K, 1.0 torr, 10 cm

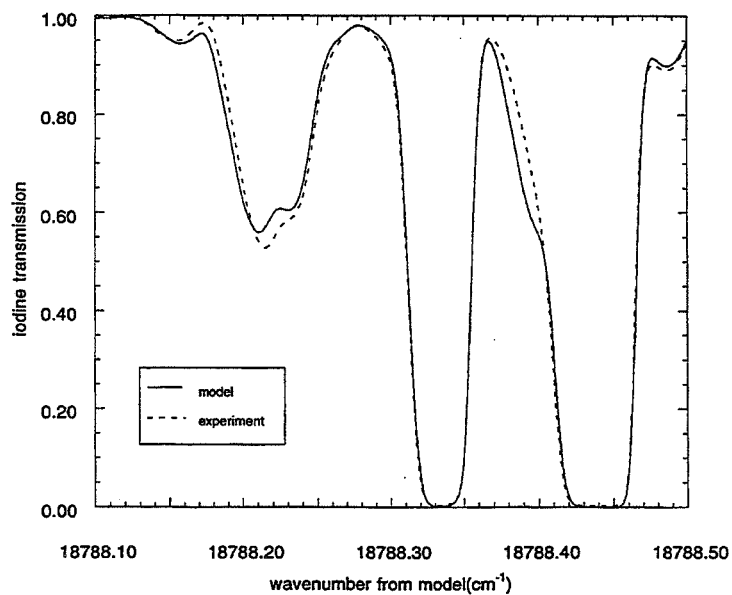

model versus data 353 K, 3.1 torr, 10 cm

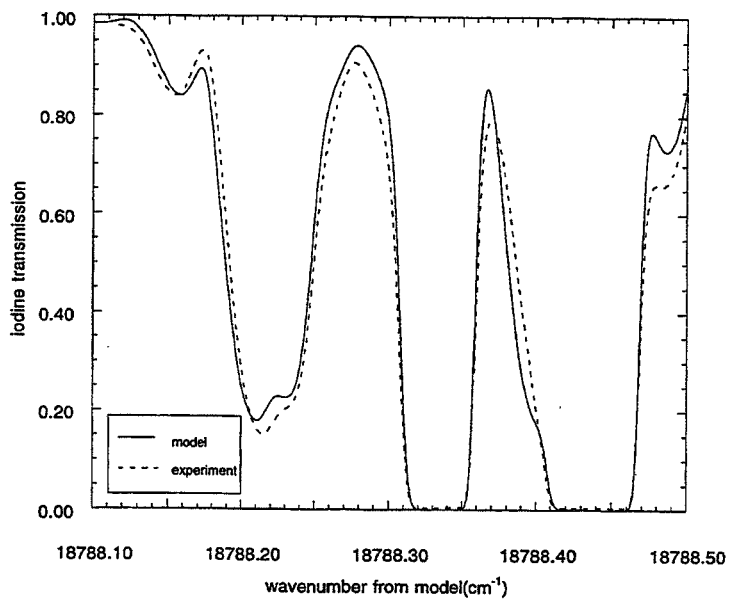

Accurate Characterization of Transmission Profile

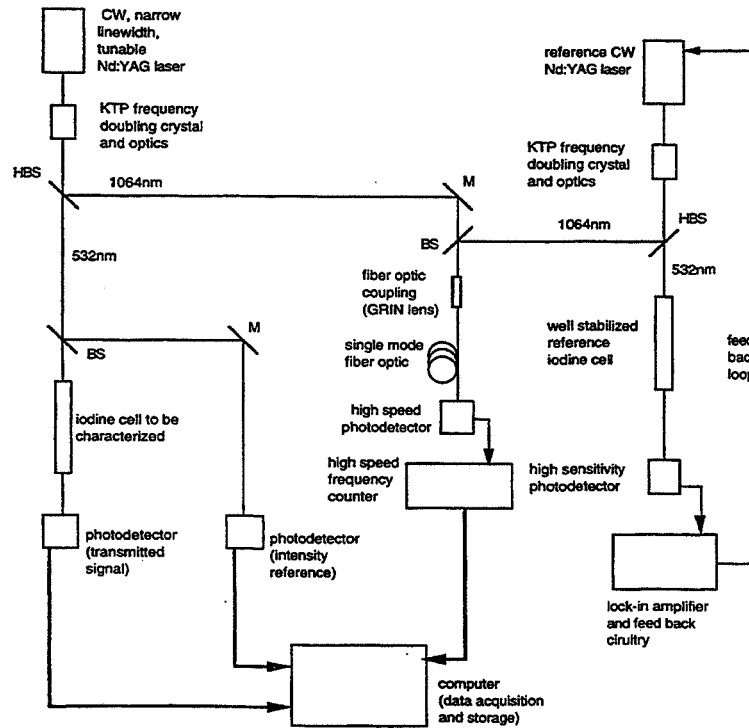

reference laser locking point

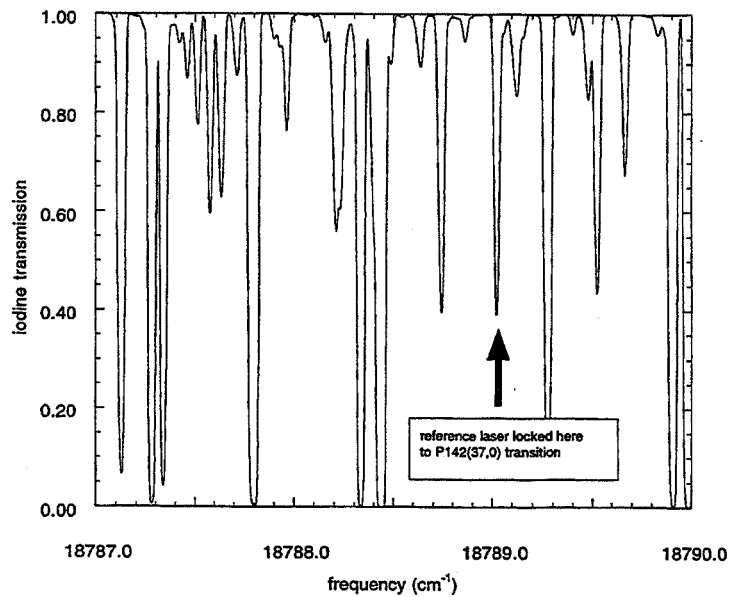

relocking of reference laser

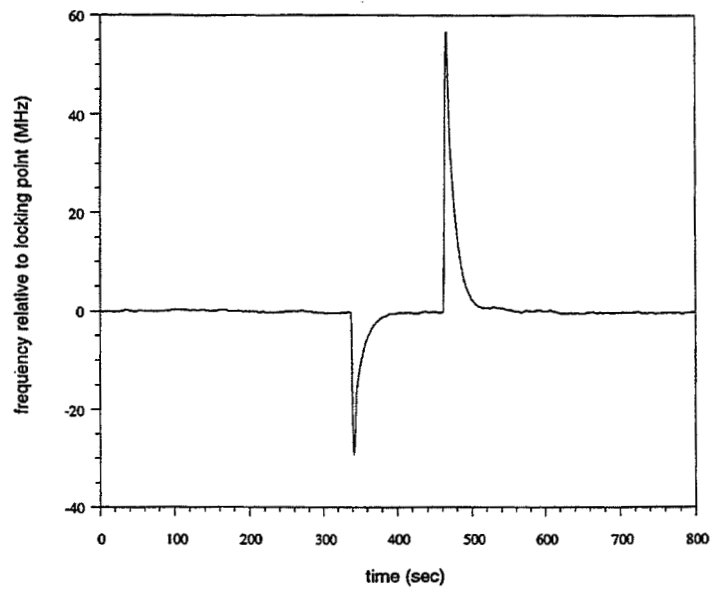

relocking of reference laser

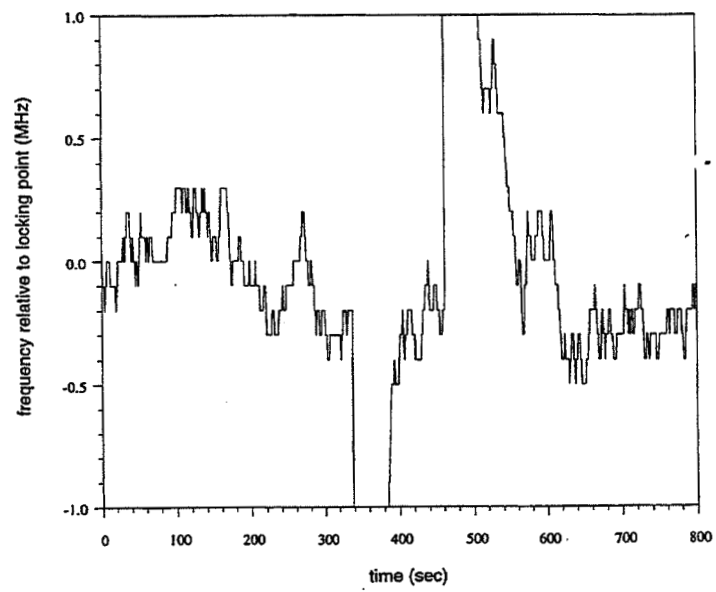

pulsed laser system

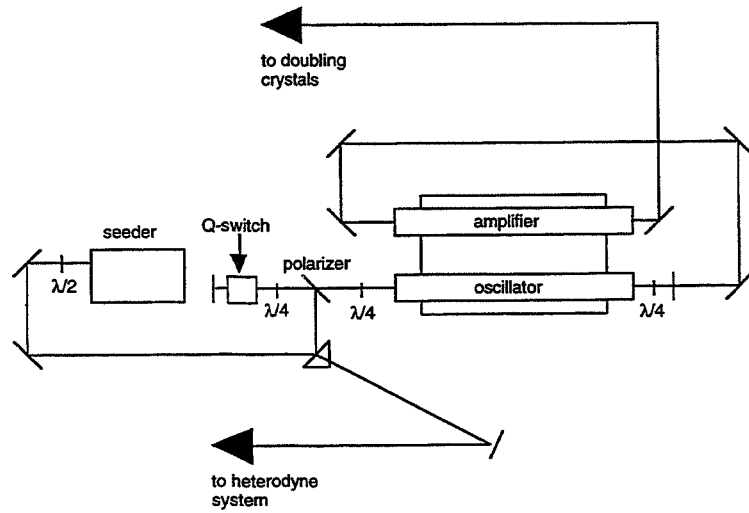

Characterization of Pulsed Laser Frequency

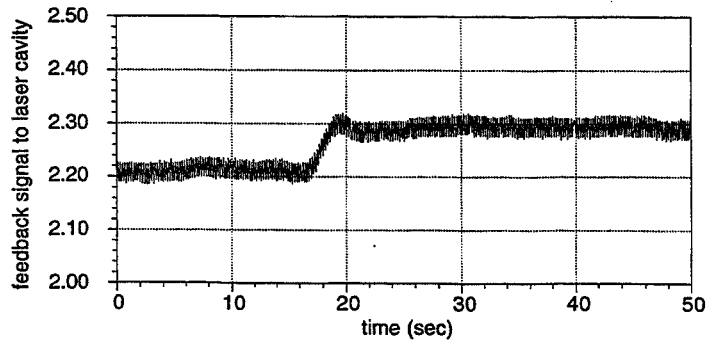
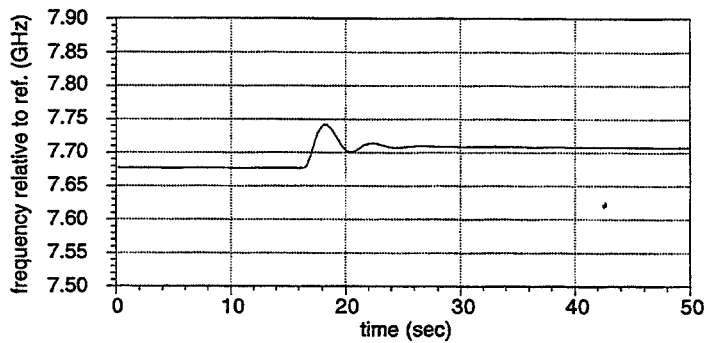

Experimental Setup

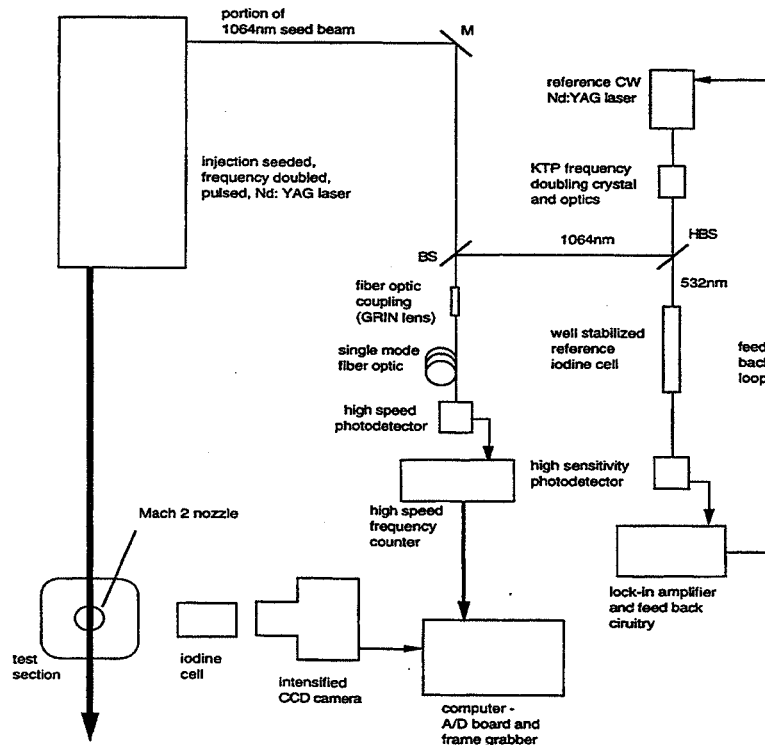

Experimental Geometry for Mach 2 Free Jet

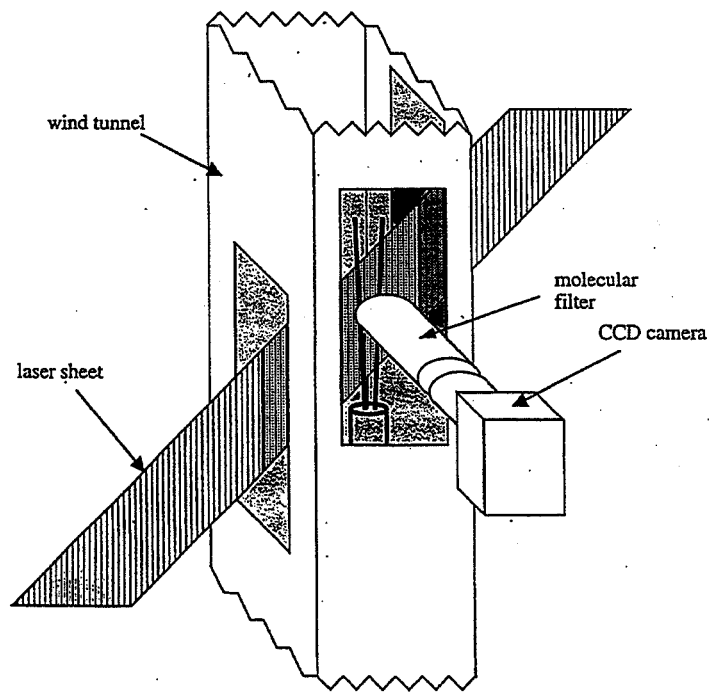

Fit to Data

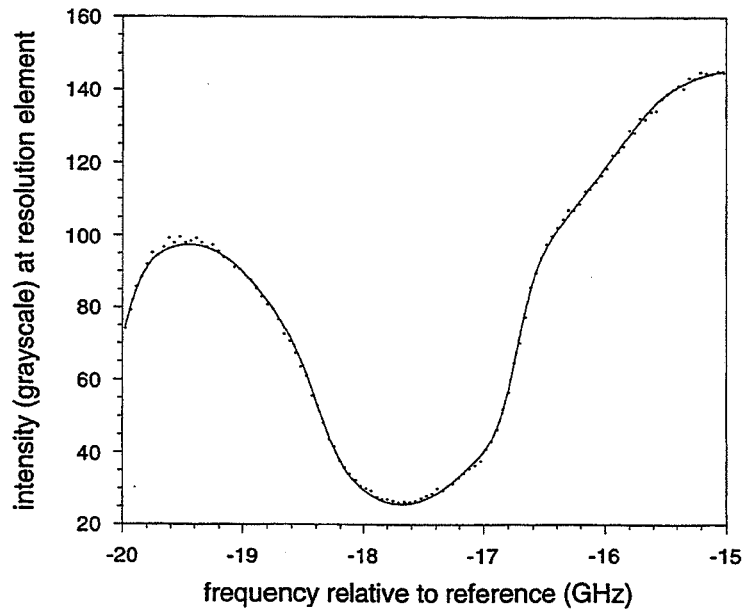

ambient air pressure (torr)

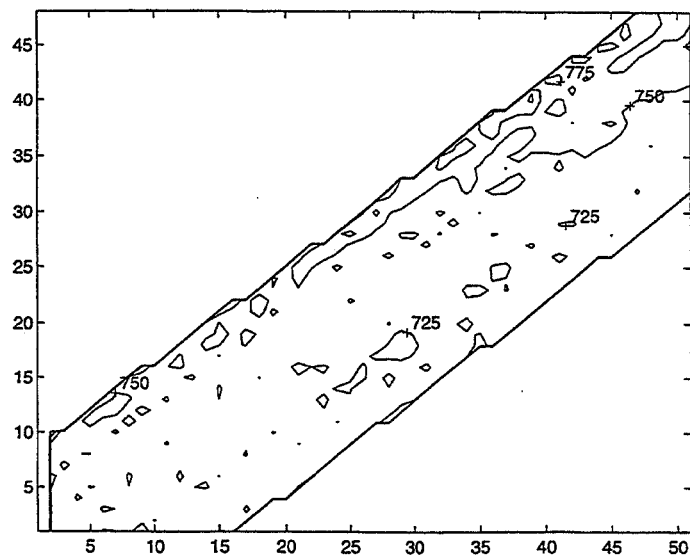

ambient air temperature (K)

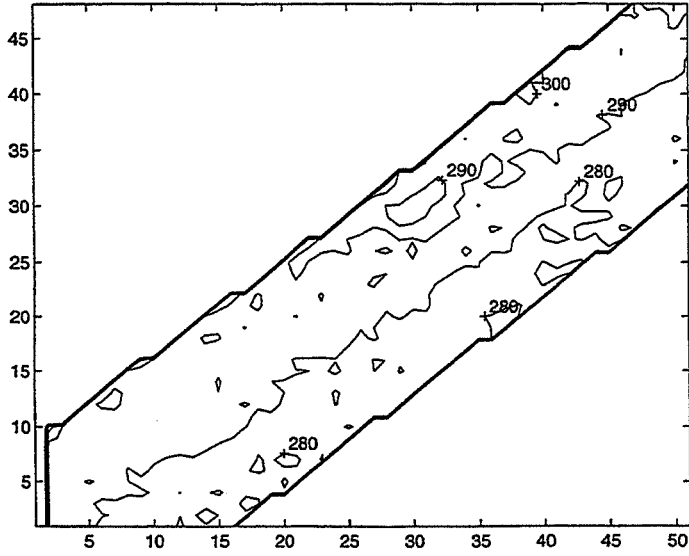

ambient air velocity (m/s)

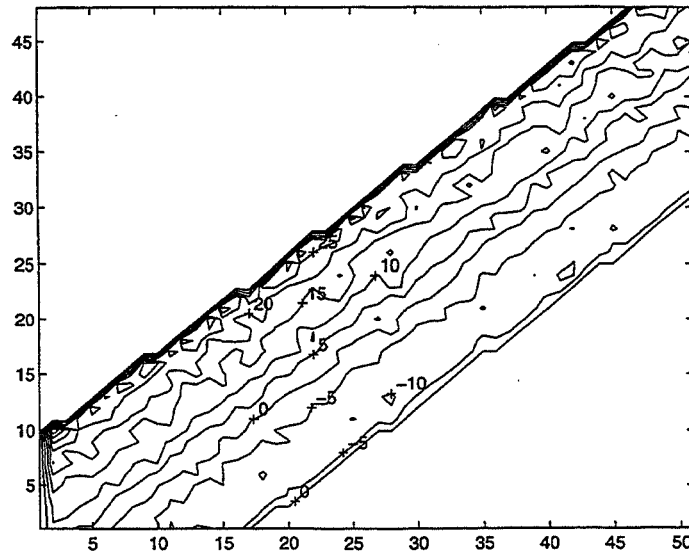

mach 2 jet static pressure (torr)

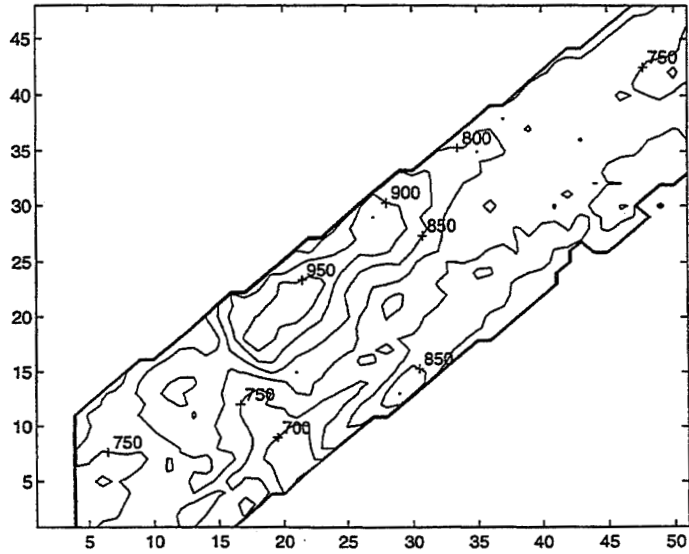

mach 2 jet static temperature (K)

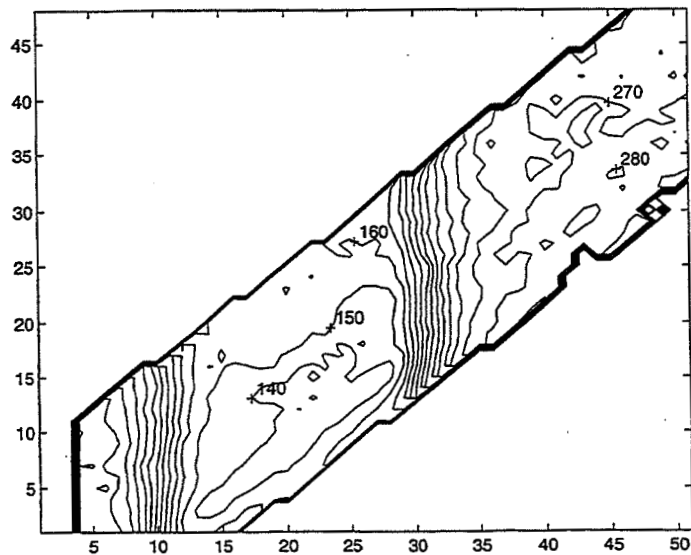

**mach 2 jet
velocity in direction
of sensitivity (m/s)**

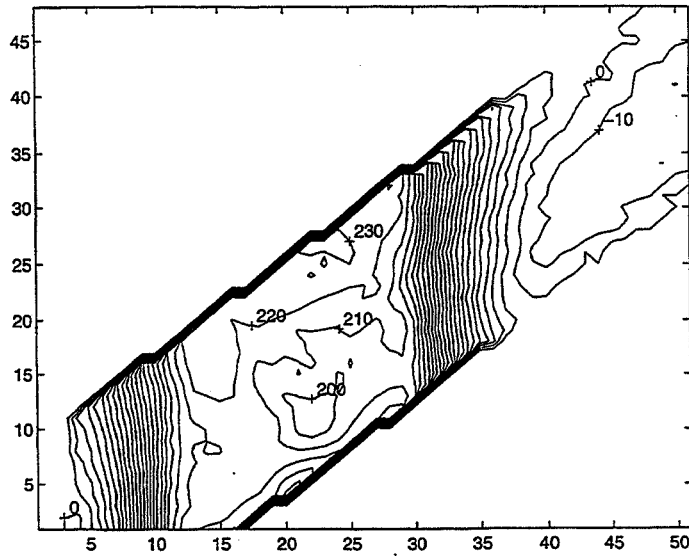

DUAL-LINE DETECTION RAYLEIGH SCATTERING MEASUREMENTS OF
DENSITY AND TEMPERATURE

57-34
79379

Kurt Annen
Aerodyne Research Corporation
Billerica, Massachusetts

0321660

Volkan Otugen
Polytechnic University
Brooklyn, New York

101.

and

Richard Seasholtz
NASA Lewis Research Center
Cleveland, Ohio

Abstract

Measurements of the laser Rayleigh scattering signal in a flow to determine density and temperature have been commonly employed in open flames and wind tunnel environments. In these measurements, the density or reciprocal temperature is correlated with the Rayleigh scattering signal intensity. A major advantage of Rayleigh scattering for these applications is the simple experimental arrangement allowed by this technique. Intensity-based Rayleigh scattering measurements of density and temperature have been limited though to relatively clean flows in open environments so that interference from particle scattering and laser scattering from surfaces is minimal. A new approach, using Dual-Line Detection Rayleigh (DLDR) scattering¹, extends the applicability of Rayleigh scattering measurements of density and temperature to enclosed environments where surface scattering interference is high. Depending on particle size and optical properties, this approach may also reduce interference from particle scattering.

The Dual-Line Detection Rayleigh scattering technique requires use of laser output at two wavelengths, such as can be produced by copper vapor, argon ion, or frequency-doubled Nd-YAG lasers. The approach uses the inverse λ^4 dependence of the Rayleigh scattering signal to discriminate between the desired Rayleigh scattered signal and interferences from surface and particle scattering, which in general do not have the inverse λ^4 dependence. Experiments performed in a hot jet using the 510 and 578 nm lines of a copper vapor laser have shown that reliable temperature measurements can be performed even when the background interference level due to surface scattering is 2.5 times higher than the Rayleigh scattering signal.¹ Potential applications for the DLDR technique for which measurement precision estimates are presented include measurements of temperature in the main shuttle main engine, the turbine inlet region of gas turbine engines, and shock induced temperature transients in gas flow lines.

¹ M.V. Otugen, K.D. Annen, and R.G. Seasholtz, "Gas Temperature Measurements Using a Dual-Line Detection Rayleigh Scattering Technique," AIAA J. 31, 2098 (1993).

DUAL-LINE DETECTION RAYLEIGH SCATTERING TECHNIQUE

MOTIVATION

- NEED FOR 'SIMPLE' NONINTRUSIVE TEMPERATURE/DENSITY DIAGNOSTIC
 - INTENSITY-BASED POINT MEASUREMENT IN RELATIVE 'CLEAN' FLOWS
 - SIMPLE DETECTION CONFIGURATION
 - COMPATIBLE WITH WIDE VARIETY OF LASER EXCITATION SOURCES
- DUAL-LINE DETECTION
 - REDUCES SURFACE-SCATTERED LASER LINE CONTAMINATION OF RAYLEIGH SCATTERING SIGNAL
 - ALLOWS MEASUREMENTS IN ENCLOSED ENVIRONMENTS

DUAL-LINE DETECTION RAYLEIGH SCATTERING TECHNIQUE

THEORY

$$E_R = E_L C \sigma n$$

$$E_T = E_R + E_B = E_L C \sigma n + E_L C C'$$

$$\frac{E_T}{E_L} = C \sigma \frac{P}{kT} + C C'$$

DUAL-LINE DETECTION RAYLEIGH SCATTERING TECHNIQUE

THEORY (CONTINUED)

$$\frac{E_{T,1}}{E_{L,1}} = \left(\frac{C_1 P \sigma_1}{\kappa} \right) \frac{1}{T} + \beta C_1 C'$$

$$\frac{E_{T,2}}{E_{L,2}} = \left(\frac{C_2 P \sigma_2}{\kappa} \right) \frac{1}{T} + C_2 C'$$

DUAL-LINE DETECTION RAYLEIGH SCATTERING TECHNIQUE

THEORY (CONTINUED)

$$T = \frac{(P/\kappa) (\sigma_1 - \beta\sigma_2)}{(E_{T,1}/E_{L,1}) (1/C_1) - (E_{T,2}/E_{L,2}) (\beta/C_2)}$$

$$C' = \frac{(E_{T,2}/E_{L,2}) (\sigma_1/C_2) - (E_{T,1}/E_{L,1}) (\sigma_2/C_1)}{(\sigma_1 - \beta\sigma_2)}$$

SINGLE-SHOT TEMPERATURE MEASUREMENT PRECISION

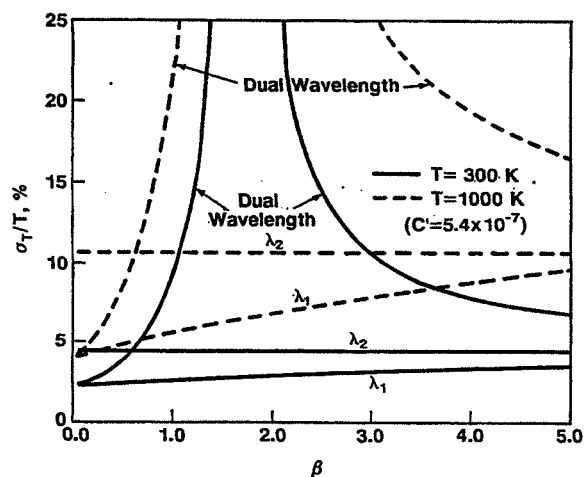

DUAL-LINE DETECTION OPTICAL CONFIGURATION

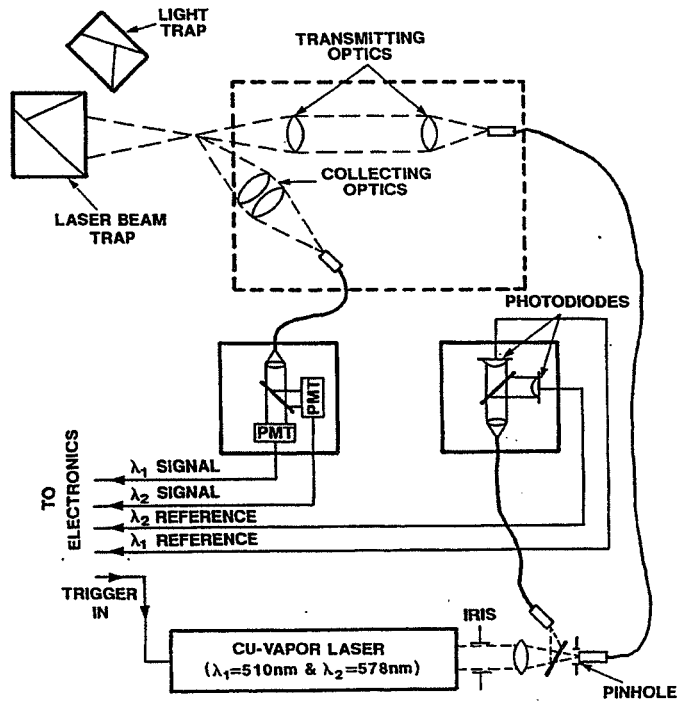

HEATED JET APPARATUS FOR SYSTEM CALIBRATION AND MEASUREMENTS

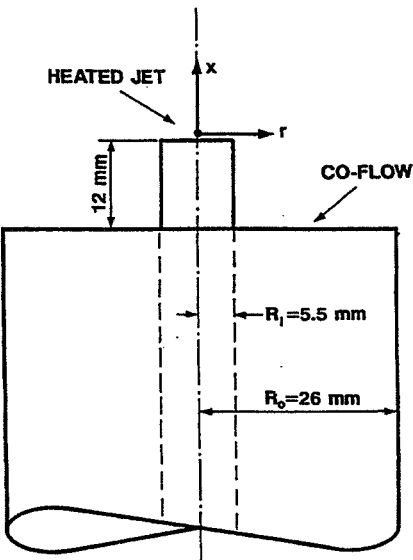

RAYLEIGH SCATTERING TEMPERATURE MEASUREMENTS USING SINGLE LINE DATA REDUCTION

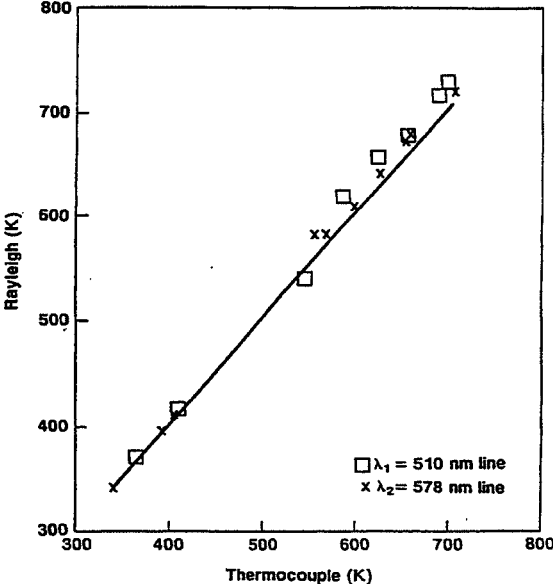

TYPICAL CALIBRATION CURVES FOR DIFFERENT BACKGROUND CONTAMINATION LEVELS

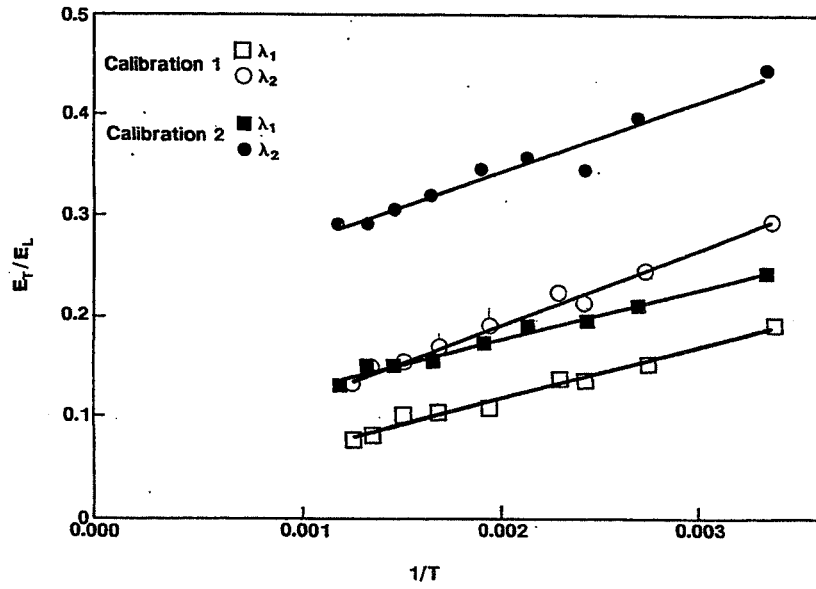

TEMPERATURE MEASUREMENTS WITH BACKGROUND LEVEL VARIATION ($T_{JET} = 380$ K)

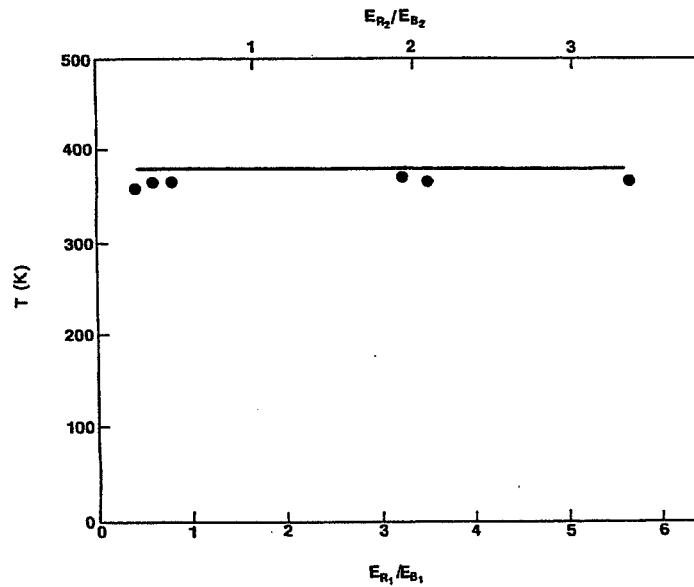

**TEMPERATURE MEASUREMENTS WITH
BACKGROUND LEVEL VARIATION
($T_{JET} = 805 \text{ K}$)**

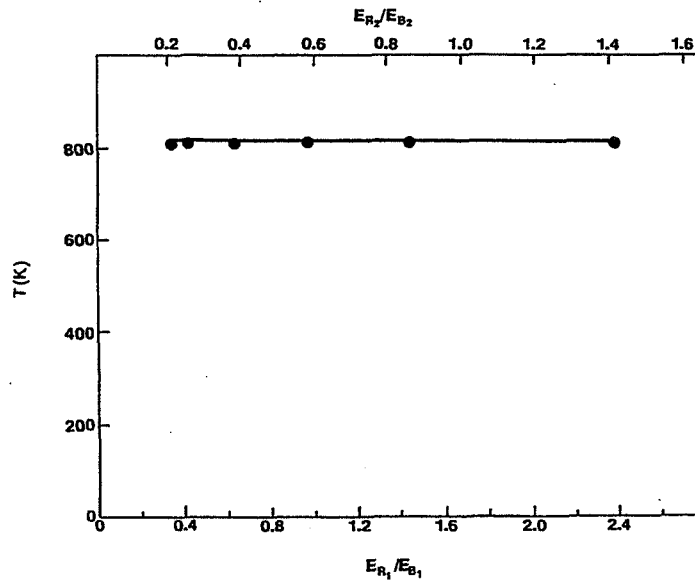

**APPLICATIONS OF DUAL-LINE DETECTION RAYLEIGH
SCATTERING MEASUREMENTS**

- **SSME TURNAROUND DUCT TEMPERATURE MEASUREMENTS**
 - VERY HIGH PRESSURE, CLEAN FLOW
- **GAS TURBINE COMBUSTOR EXIT TEMPERATURE MEASUREMENTS**
 - MODERATE PRESSURE, RELATIVELY CLEAN FLOW
- **HIGH PRESSURE FLEX HOSE TEMPERATURE MEASUREMENTS**
 - HIGH PRESSURE, CLEAN, TRANSIENT FLOW

COMBUSTOR TEMPERATURE MEASUREMENT PROBE

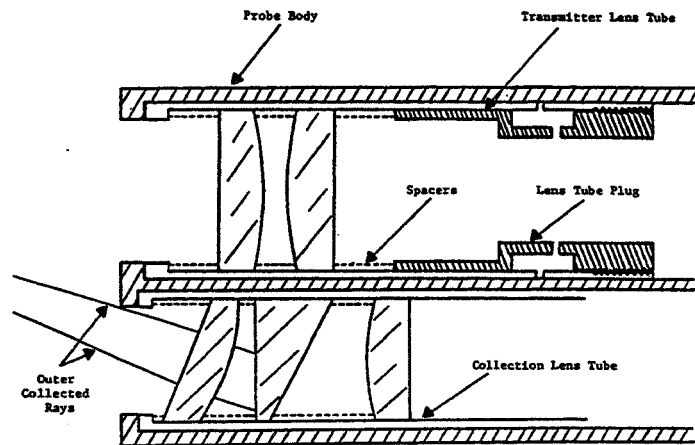

FLEX HOSE TEMPERATURE PROBE

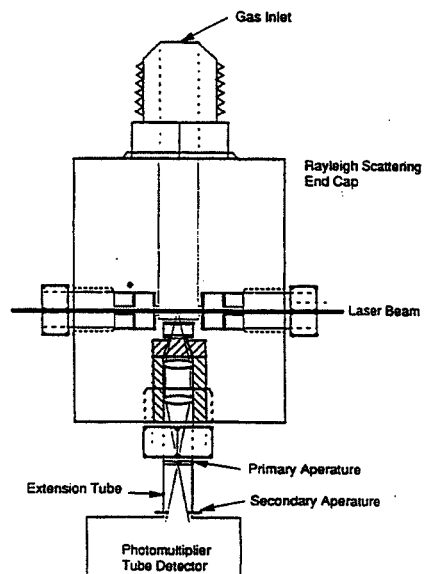

RAYLEIGH SCATTERING PROBE CHARACTERISTICS

- **GAS TURBINE COMBUSTOR EXIT PROBE**
 - **RAYLEIGH SCATTERING/BACKGROUND LEVEL ~1**
 - **WATER-COOLED PROBE DESIGNED FOR 500 W/cm² HEAT FLUX**
 - **0.05 mm³ MEASUREMENT VOLUME**
 - **1.7% SINGLE SHOT TEMPERATURE MEASUREMENT PRECISION AT 1200 K, 20 atm CONDITIONS AND 5 kHz Cu VAPOR LASER REP RATE**
 - **0.2 % SINGLE SHOT MEASUREMENT PRECISION FOR SSME CONDITIONS**
- **FLEX HOSE PROBE**
 - **RAYLEIGH SCATTERING/BACKGROUND LEVEL ~0.2 - 0.5**
 - **1.3% PRECISION FOR 0.1 ms INTEGRATION AT 10 atm 580 K**
0.3% PRECISION FOR 0.1 ms INTEGRATION AT 5000 psi, 1600 K
(ASSUMING 1.5 W Ar ION LASER AT 488 nm)

CONCLUSIONS

- **DUAL-LINE DETECTION RAYLEIGH SCATTERING MEASUREMENT TECHNIQUE ALLOWS TEMPERATURE AND DENSITY MEASUREMENTS TO BE PERFORMED WITH BACKGROUND LEVELS AS HIGH AS 2 - 5 TIMES THE RAYLEIGH SCATTERING SIGNAL LEVEL.**
- **RAYLEIGH SCATTERING/BACKGROUND RATIOS ON THE ORDER OF 0.5 - 1 OR HIGHER FOR ENCLOSED ENVIRONMENTS CAN BE OBTAINED WITH CAREFUL PROBE DESIGN.**

Nd:YAG LASER-BASED DUAL-LINE DETECTION RAYLEIGH SCATTERING AND CURRENT
EFFORTS ON UV, FILTERED RAYLEIGH SCATTERING

M. Volkan Otugen and Svetozar Popovic
Polytechnic University
Brooklyn, New York

58-34

79380

232661

201.

Extended Abstract

Ongoing research at Polytechnic University in Rayleigh scattering diagnostics both for variable density low speed flow applications and for supersonic flow measurements will be described. During the past several years the focus has been on the development and use of a Nd:YAG-based Rayleigh scattering system with improved signal-to-noise characteristics and with applicability to complex, confined flows. This activity aimed to serve other research projects in the Aerodynamics Laboratory which required the non-contact, accurate, time-frozen measurement of gas density, pressure and temperature (each separately), in a fairly wide dynamic range of each parameter. Recently, with the acquisition of a new seed-injected Nd:YAG laser, effort has also been directed to the development of a high-speed velocity probe based on a spectrally-resolved Rayleigh scattering technique.

Dual-Line Detection Rayleigh Scattering:

The present Nd:YAG-based dual-line detection Rayleigh (DLDR) system is similar to the one developed several years ago at NASA Lewis Research Center which uses a copper vapor laser¹. In this technique, the second and fourth harmonic lines of the YAG laser are used simultaneously to determine the number density of the interrogated gas. The use of two lines through the same transmitting and collecting optics allows the determination and removal of the background (laser glare due to surfaces near the probe) from the Rayleigh signal which improves the applicability of Rayleigh scattering to confined flows.

Central to the system is a Nd:YAG laser with second (532 nm) and fourth (266 nm) harmonic generating crystals. After the second harmonic generator (SHG), the

residual 1064 nm energy is removed using a harmonic separator. The remaining green (532 nm) line is then passed through a half-wave plate so that its wave vector is 45 deg. to the horizontal. Next the green beam goes through the FHG where approximately 12% of the initial green energy is converted to 266 nm frequency. The beam containing both the green and UV lines is then focused into a narrow-waist probe volume through an achromat specially designed for the two frequencies. The waist of the probe is approximately 200 μm . The Rayleigh light scattered at both frequencies is collected normal to the beam and in the horizontal plane which is at ± 45 deg. to the each wave vector of the incident beam (after the FHG the green and the uv wave vectors are normal to each other). This is the optimum collection angle with the given set of optical components. The collimated signal is then color separated using a dichroic beam splitter and signal at each frequency is filtered (to eliminate any cross-contamination) and fed to two photomultiplier tubes (PMT). To eliminate the effect of laser shot-to-shot energy variations, scattered green and uv light near the probe is also collected by two photodiodes (PD) and the signal for each line is normalized by the respective laser energy. The output from the PMTs are fed to a boxcar averager and the PD signals are fed to a sample-and-hold unit all to be digitized by a 12-bit A/D converter and stored in a personal computer. The timing for the boxcar averager, sample and hold units and the A/D board are all provided by the TTL output synchronized with the laser's Q-switch pulse.

Extensive tests were performed to qualify the new DLDR system. Calibration tests were undertaken both using a heated air jet and a vacuum cell. These calibrations were repeated several times starting, initially, with no background contamination and gradually increasing the background intensity to study the effect of background on calibration and to determine the background coefficient ratio, $\beta = C'_g/C'_{uv}$. Here, C'_g and C'_{uv} are the green and uv surface scattering coefficients, respectively. The surface scattered background was obtained using plane aluminum plates. The value of β was found to be 2.15 ± 0.11 indicating that green scattering is twice as efficient as that for uv. The calibrations using heated air jet (temperatures between 292 and 775 K) and a vacuum cell (pressures from about 1100 torr down to about 130 torr) showed that the calibration coefficients, C_g and C_{uv} can be determined with an uncertainty of about 3%. Of course, this level of confidence does require considerable effort to "fine tune" the DLDR system and the calibration setup.

Next vacuum pressures are measured using the DLDR system (in the range 8 and 80 torr) to test the effective dynamic range of the system and to assess its capability to measure time-frozen vacuum pressures. These measurements were then compared to the estimated uncertainties due to shot noise (determines the measurement precision level) and

errors in the determination of the calibration constants (indicates the measurement accuracy). At each pressure 1000 individual realizations (laser shots) were obtained and the mean value as well as the standard deviation were plotted on the same graph. The mean values were quite close to the pressure gage measured values. - The standard deviations were only slightly larger than the estimated shot noise uncertainties.

The comparison of pressure measured by the green line only, the uv line only and the DLDR technique reveal that in the presence of high levels of background, the best and the worst results are obtained by the DLDR and the green line only systems, respectively. The uv line only pressure results are indeed quite close to those obtained by the DLDR. This is due to the fact that the uv Rayleigh scattering cross-section is 16 times larger than that for the green while the surface scattering is only half that of green. The combined effect is that the uv signal-to-background ratio is over 30 times larger than that of green. Therefore, using uv line only is already a major improvement over using the green line alone. Through further tests it was determined that the DLDR technique works robustly up to a level where the background-to-signal level on the green line is approximately 3. At this degree of background contamination, the uv background-to-signal levels will be approximately 0.1. This is still a significant improvement in measurement accuracy over the uv- only measurements.

Further tests were performed in a heated air jet facility with a co-flow. The jet facility is confined in a cylindrical enclosure to protect it from particulate contamination, which adds considerable surface-scattered laser glare. Temperature results obtained by the DLDR system closely match those measured by a constant current anemometry giving further credence to the new DLDR technique.

Spectrally-Resolved UV Rayleigh Scattering:

The goal of this effort is to develop a Rayleigh velocity probe for high speed velocity diagnostics which is based on the shorter wavelengths of a line-narrowed Nd:YAG laser, including the 266 nm fourth harmonic line and which utilizes a gas absorption filter (similar to iodine vapor used in conjunction with the 532 nm line) to block out the unshifted laser line reflected from surfaces surrounding the test section. High speed ground testing carried out in supersonic wind tunnels have various restrictions and present a number of difficulties. One of the more formidable restrictions is the optical access and a major difficulty is associated with surface scattering of laser line from test section walls and windows. The use of shorter incident wavelengths, especially in the uv range, significantly improves the Rayleigh signal-to-surface scattered background ratio due to the increased Rayleigh scattering cross-section and diminished surface scattering at

shorter wavelengths, as discussed earlier. However, surface scattering can still affect the quality of the Doppler-shifted Rayleigh signal under certain optical configurations. The present research aims to minimize this problem by trying to identify a suitable gas which has fine absorption structures around 266 nm wavelength.

The activity on the development of a molecular absorption filter for the FH of the Nd:YAG laser has been concentrated around the testing of benzene and its derivatives. Benzene and its derivatives are the group of organic molecules that have strong absorption bands in the general region which overlaps the tunable range of the FH of the injection-seeded laser (around 266 nm). The first absorption band of benzene is centered at 255 nm. It is followed by more than 30 bands shifted towards shorter further towards lower wavelengths. The gas absorption spectrum of benzene looks similar to that of iodine in the visible spectrum with some fine structures. The substitution on the benzene ring by auxochromic groups or hyboges reduces the symmetry of the new molecule. This change results in a red-shift of the spectral bands as well as an increase in the absorption intensities. Therefore, most of the benzene substitutes are potential strong absorbers around 266.1 nm. On the down side, the red-shift and increased intensity of the spectral bands can in some cases result in the reduction of the fine structures.

In order to be applicable to Rayleigh scattering, the absorption lines of the molecular filter has to have sharp spectral structures in the laser's tuning range. This can be a single isolated spectral line or a sharp "head" of an absorption band. The ultraviolet absorption spectra of gas phase benzene derivatives are available in the literature. However, the spectral resolution of available data is too poor to be useful for Rayleigh scattering applications. Therefore, we are currently studying the absorption spectrum of several compounds in the 266 nm range using the tunable YAG laser.

Reference:

M.V. Otugen, K.D. Annen and R.G. Seasholtz, "Gas Temperature Measurements Using a Dual-Line Detection Rayleigh Scattering Technique", AIAA Journal, Vol. 31, No. 11, November 1993, pp. 2098-2104.

PRESENTATION OUTLINE

- o Nd:YAG laser-based DLDR System
- o Measurements using the new DLDR system
- o UV filter characterization efforts for Rayleigh scattering

DUAL-LINE DETECTION RAYLEIGH SCATTERING SYSTEM

- o For time-frozen, local measurements of temperature and pressure
- o Uses 532 nm and 266 nm lines of the Nd:YAG laser
- o The two lines are focused at the probe volume using a special achromat
- o A single set of collecting optics used
- o Rayleigh scattered light is collected at $\pm 45^\circ$ angle to polarization dir.
- o Green and UV signal analyzed separately

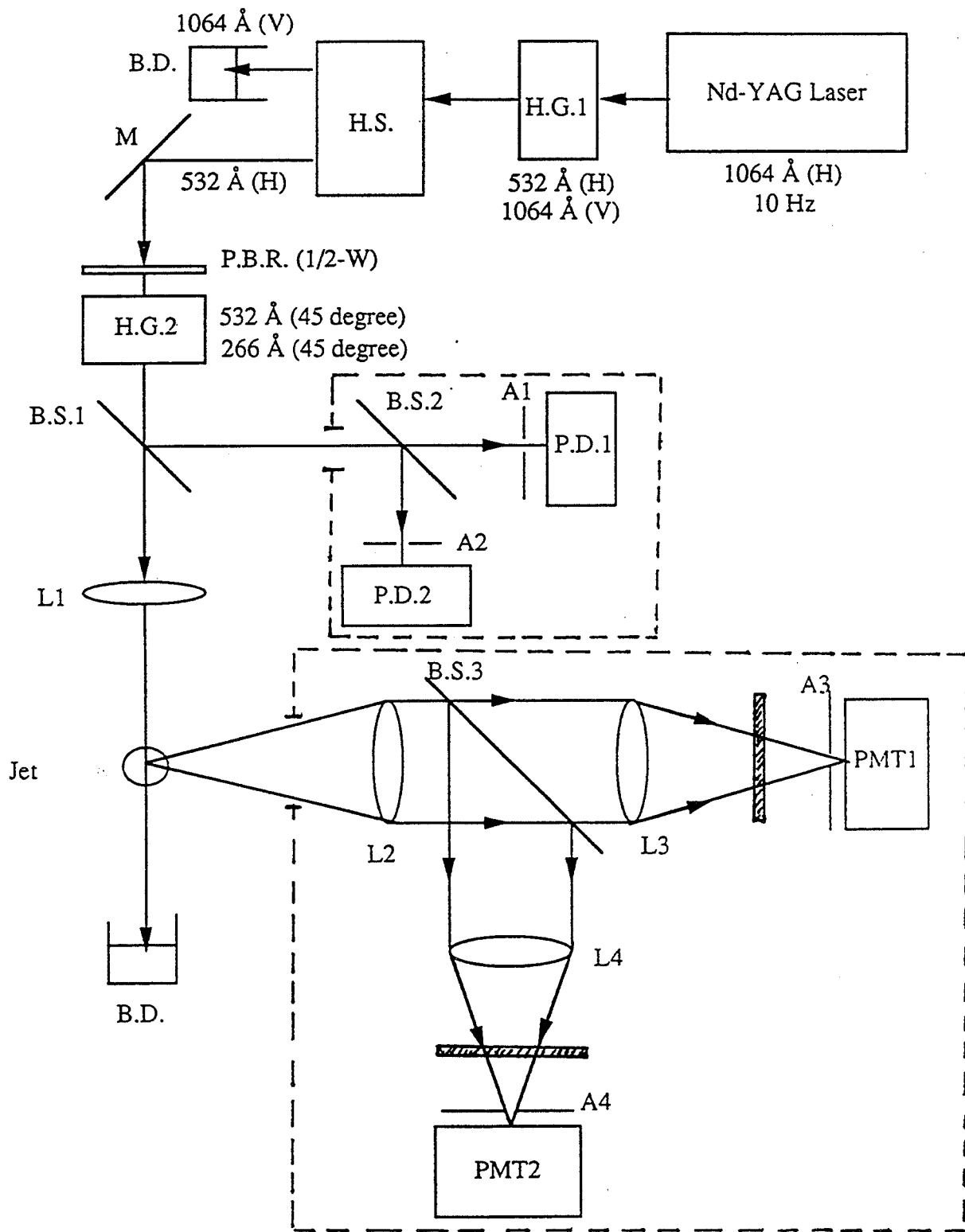

Optical arrangement for Rayleigh scattering measurement

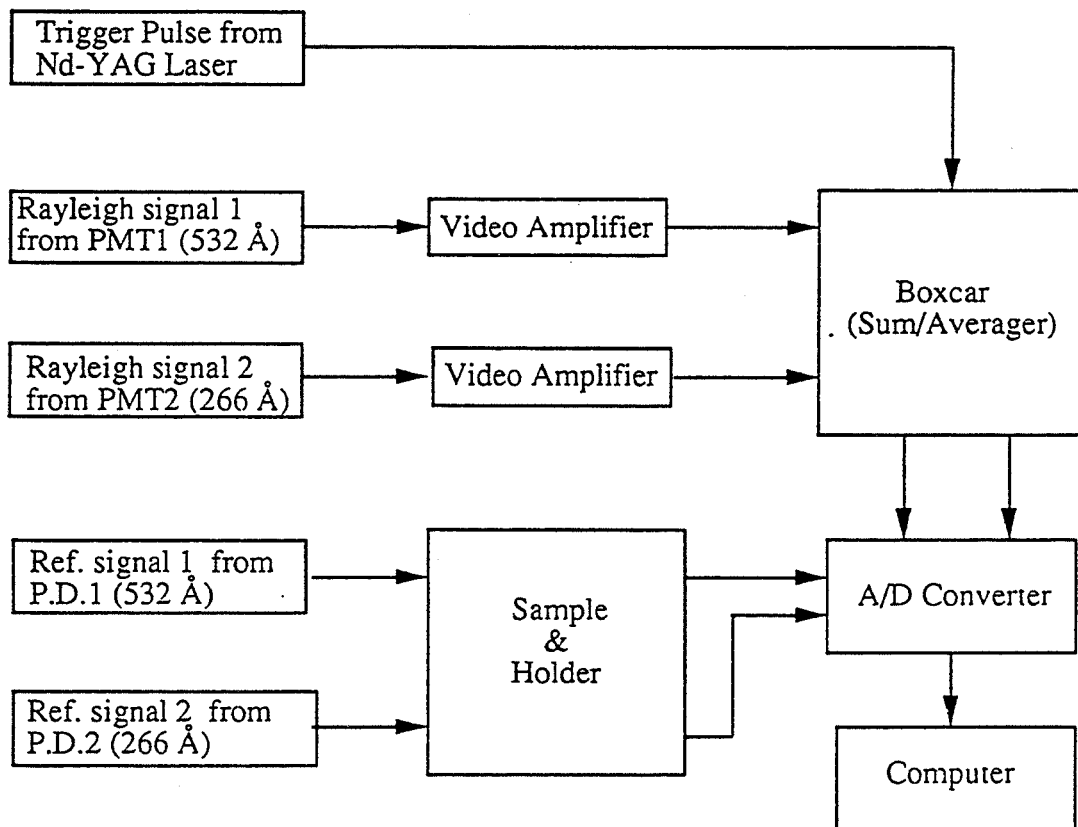

Schematic diagram of the Rayleigh signal acquisition

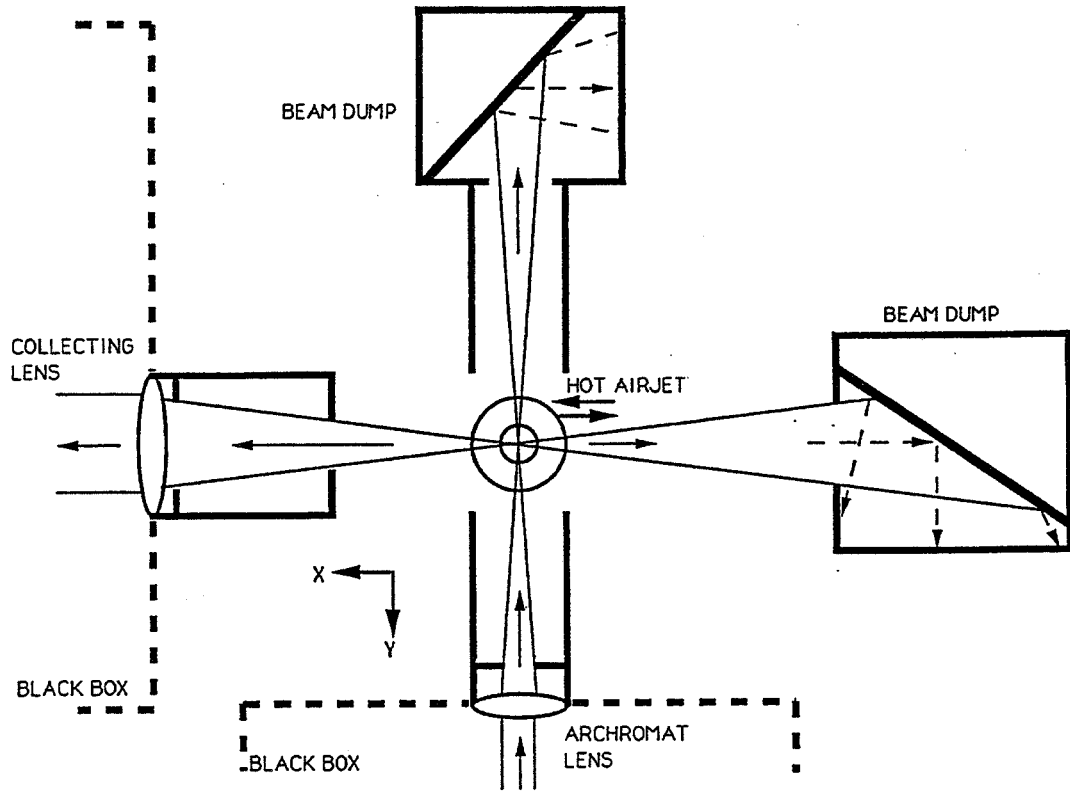

DLDR EQUATIONS FOR PRESSURE

$$\frac{E_{T,g}}{E_{L,g}} = \left(\frac{C_g \sigma_g}{kT} \right) P + \beta C_g C'$$

$$\frac{E_{T,uv}}{E_{L,uv}} = \left(\frac{C_{uv} \sigma_{uv}}{kT} \right) P + C_{uv} C'$$

$$P = \frac{\frac{E_{T,g}}{E_{L,g}} \frac{1}{C_g} - \frac{E_{T,uv}}{E_{L,uv}} \frac{\beta}{C_{uv}}}{\frac{\sigma_g - \sigma_{uv} \beta}{kT}}$$

$$C' = \frac{\frac{E_{T,uv}}{E_{L,uv}} \frac{\sigma_g}{C_{uv}} - \frac{E_{T,g}}{E_{L,g}} \frac{\sigma_{uv}}{C_g}}{\beta \sigma_g - \sigma_{uv}}$$

DLDR Cal 1 (Jet Apparatus)

std (g)=3% ; std (uv)=4.2%

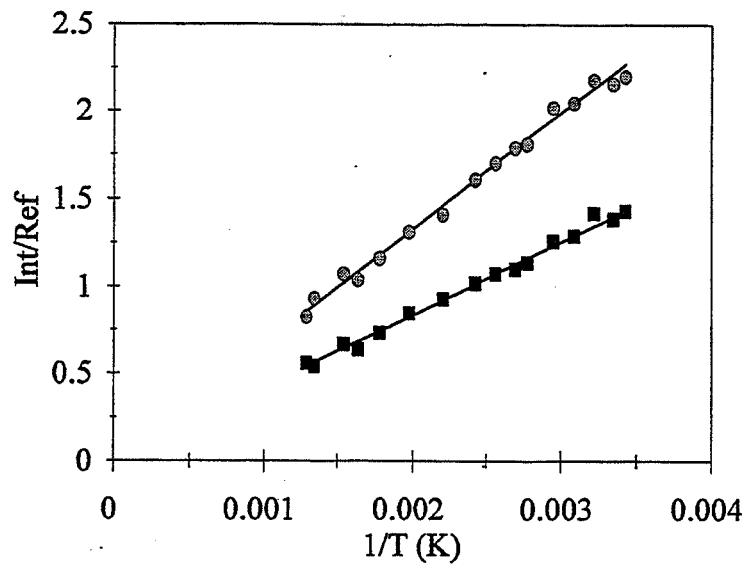

■ Green line ○ UV line

DLDR Cal 2 (Jet Apparatus)

std (g)=5.2 ; std (uv)=4.1

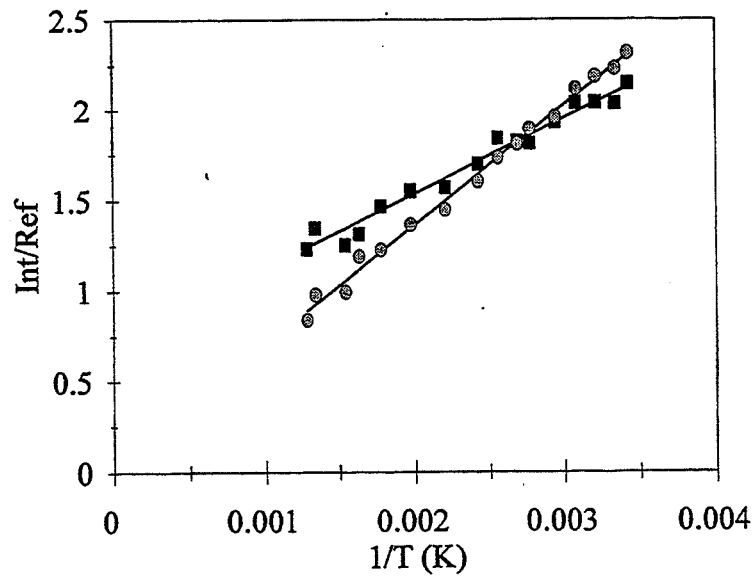

■ Green line ○ UV line

Cal. 1 parameters:

$$C_g = 1.367 \times 10^6$$

$$C_{uv} = 1.336 \times 10^5$$

$$C'_g = \text{----}$$

$$C'_{uv} = \text{----}$$

$$C'_g/C'_{uv} = \beta = ?$$

Cal. 2 parameters:

$$C_g = 1.390 \times 10^6$$

$$C_{uv} = 1.351 \times 10^5$$

$$C'_g = 5.120 \times 10^{-7}$$

$$C'_{uv} = 2.415 \times 10^{-7}$$

$$C'_g/C'_{uv} = \beta = 2.12$$

AIR JET CALIBRATION SUMMARY

(Average of six calibrations at the same
optical/electronic settings)

Calibration constants:

$$C_g = 1.365 \times 10^6 \quad (\pm 0.047 \times 10^6)$$

$$C_{uv} = 1.354 \times 10^5 \quad (\pm 0.040 \times 10^5)$$

Background scattering ratio:

$$C'_g/C'_{uv} = 2.15 (\pm 0.11)$$

DLDR Cal 2 (Vacuum Chamber)

std (g) = ; std (uv) =

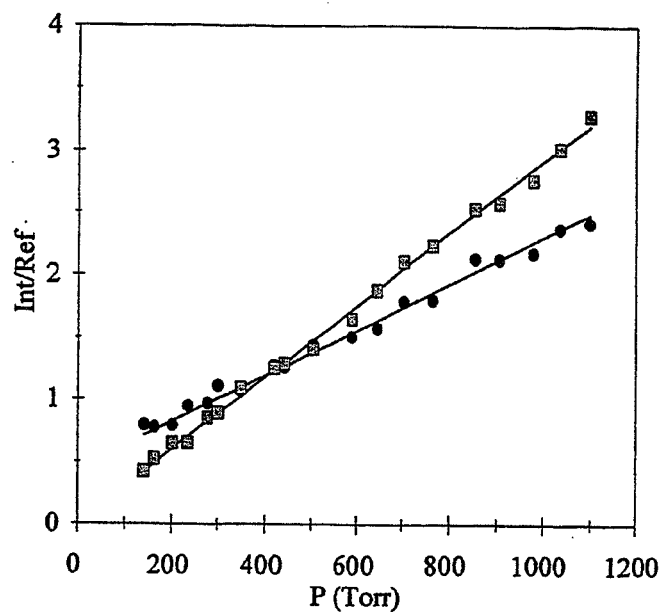

● Green line ■ uv line

DLDR Cal 1 (Vacuum Chamber)

std (g)=4% ; std (uv)=3.4%

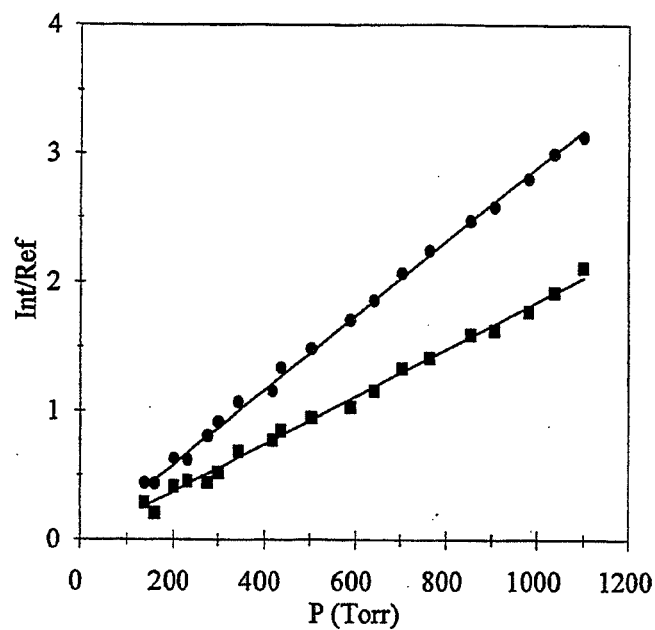

■ Green line ● UV line

Cal. 1 parameters:

$$C_g = 1.401 \times 10^6$$

$$C_{uv} = 1.372 \times 10^5$$

$$C'_g = \text{----}$$

$$C'_{uv} = \text{----}$$

$$C'_g/C'_{uv} = \beta = ?$$

Cal. 2 parameters:

$$C_g = 1.379 \times 10^6$$

$$C_{uv} = 1.385 \times 10^5$$

$$C'_g = 3.297 \times 10^{-7}$$

$$C'_{uv} = 1.585 \times 10^{-7}$$

$$C'_g/C'_{uv} = \beta = 2.08$$

**Calculated uncertainty levels
(shot noise and calibration accuracy)**

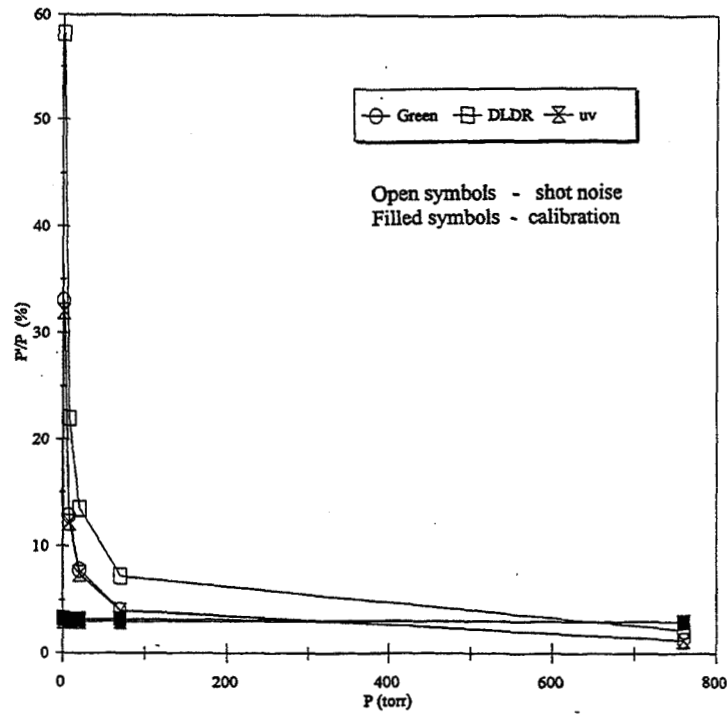

Calculated uncertainty levels
(shot noise and calibration accuracy)

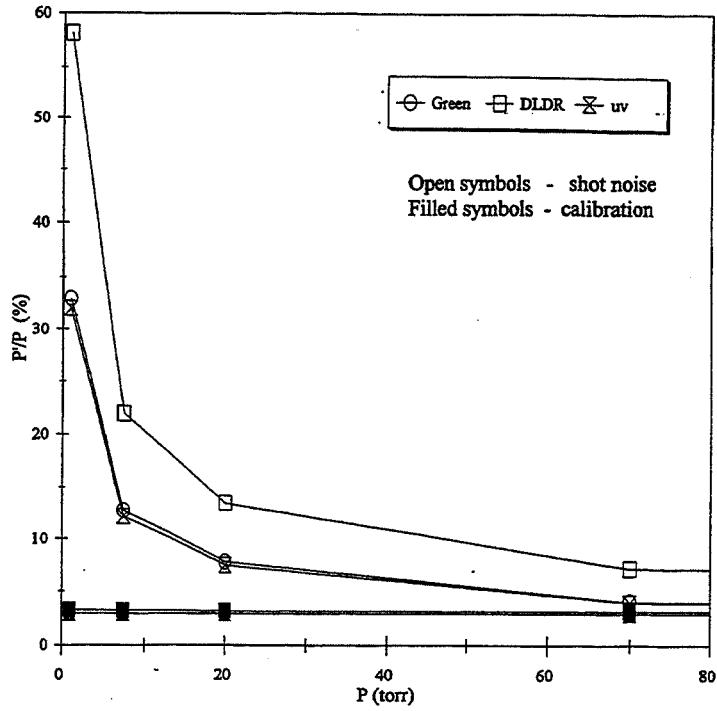

Pressure measurements in vacuum
($T = 298$ K, No background)

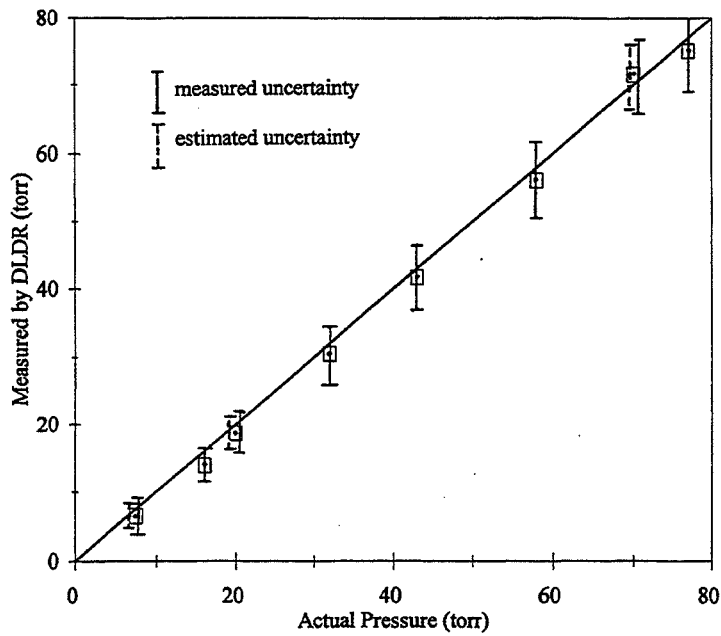

Pressure Measurement with Background
(T = 301 K)

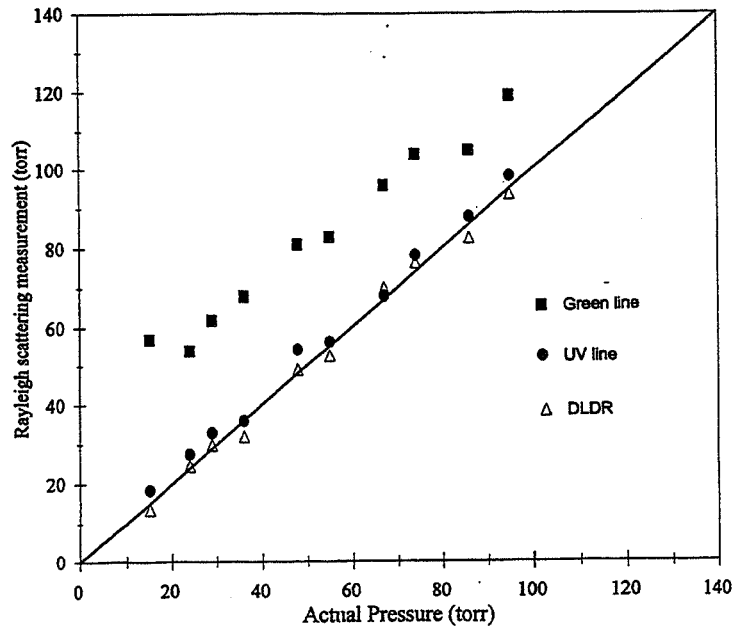

DLDR Pressure measurement
(T=298 K ; P=505 torr ; N=1000)

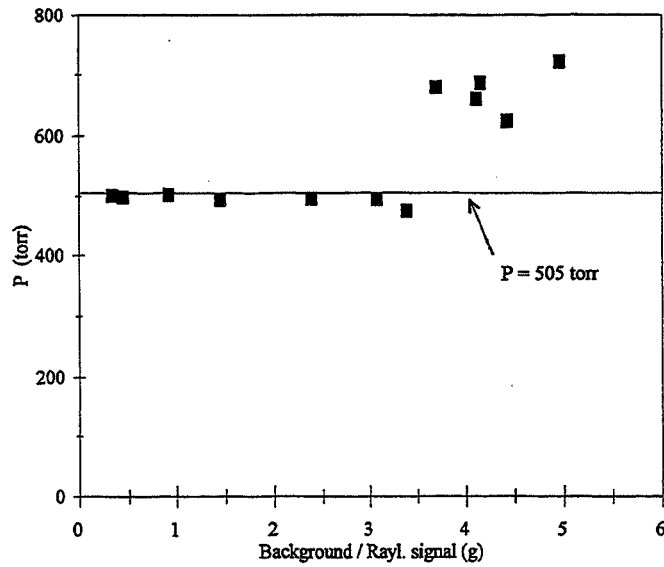

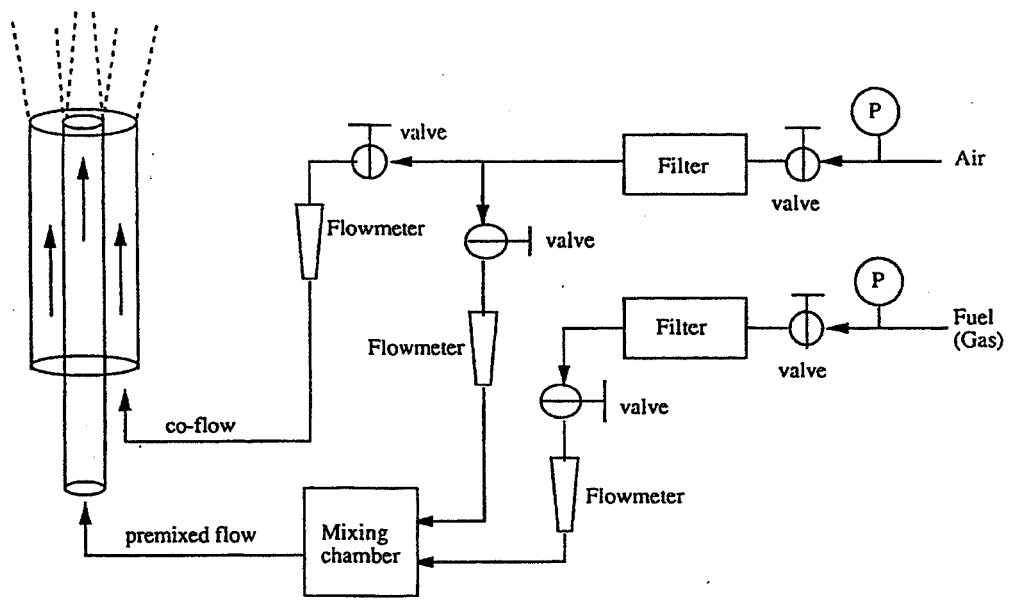

Mean temperature profile in jet
($x/d = 5$)

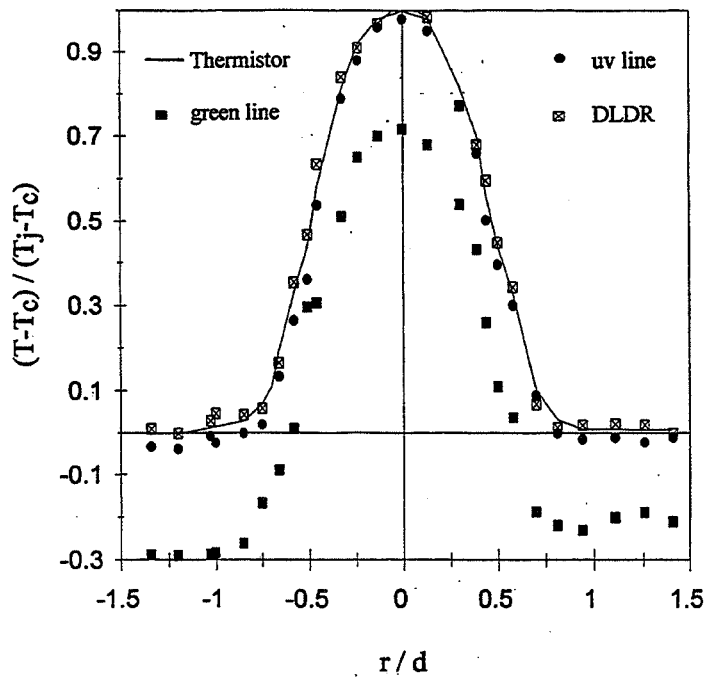

**Turbulent temperature profile in jet
($x/d = 5$)**

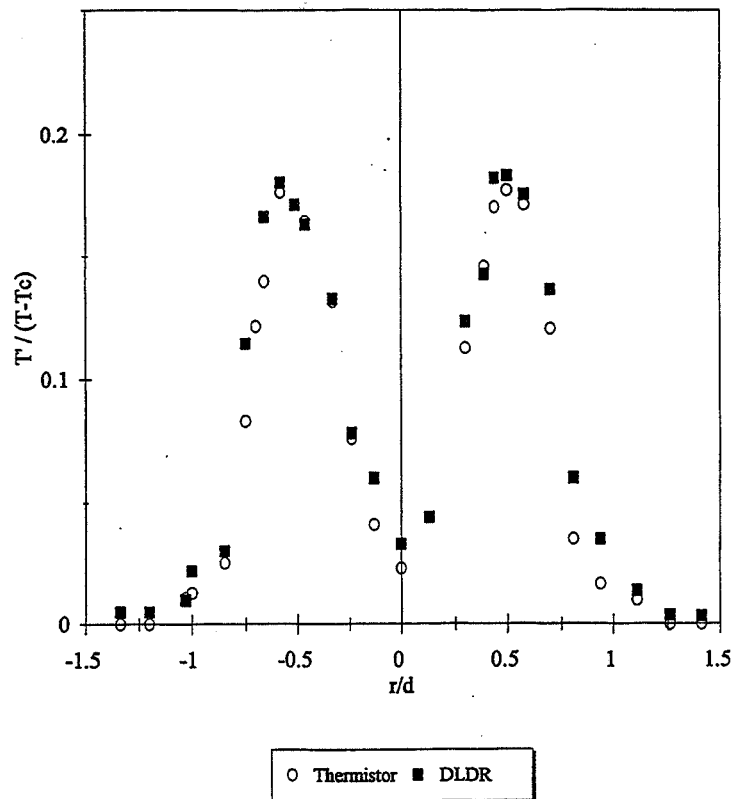

UV FILTER

OBJECTIVE: Develop a molecular absorption filter for 266nm, similar to I_2 for 532 nm

Laser tuning range:

$$k = 37578 - 37580 \text{ cm}^{-1}$$

$$\lambda = 266.099 - 266.113 \text{ nm}$$

Investigate the following spectral characteristics:

- (a) Isolated spectral line
- (b) Spectral band structure
- (c) Head of a spectral band

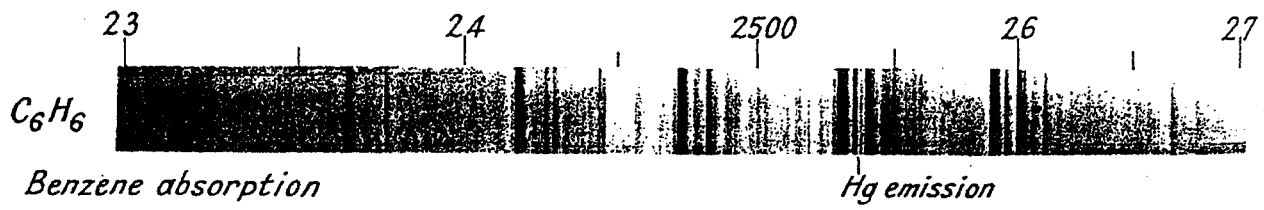

UV Filter Material Testing

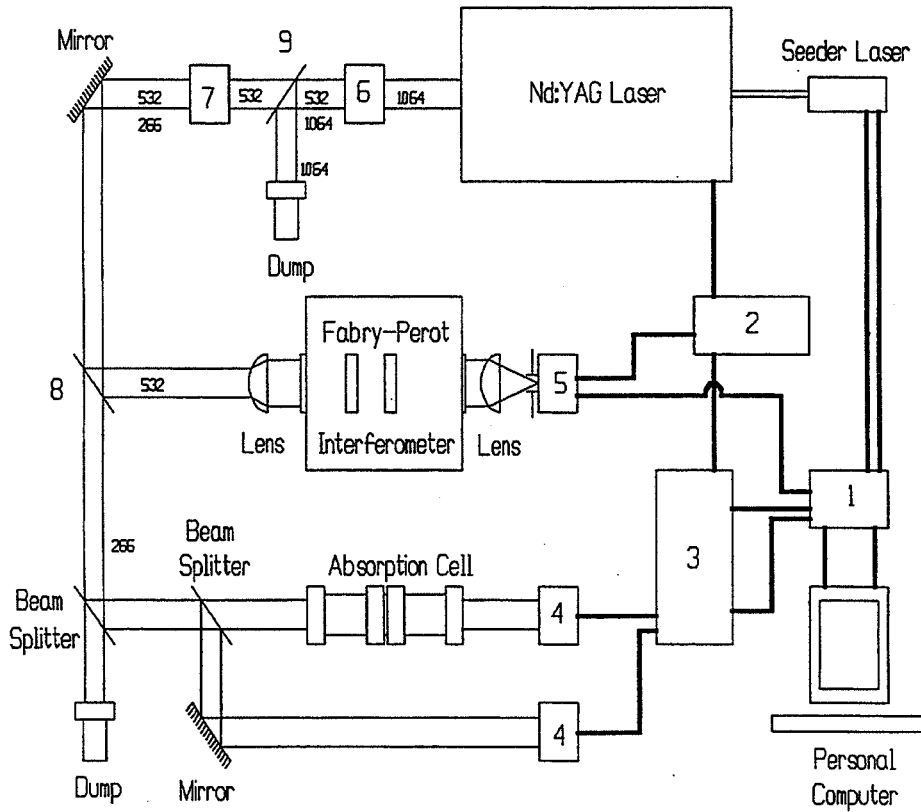

1	Digital/Analog Converter Board
2	Timing Module
3	Boxcar Averager
4	Photomultiplier Tube
5	CCD Camera
6	Second Harmonic Generator
7	Fourth Harmonic Generator
8	Harmonic Separator (532/266 nm)
9	Harmonic Separator (532/1064 nm)

April 3, 1995

Frequency Shift

Crystal Temp. @ 0 pin9 Voltage= 2.937V

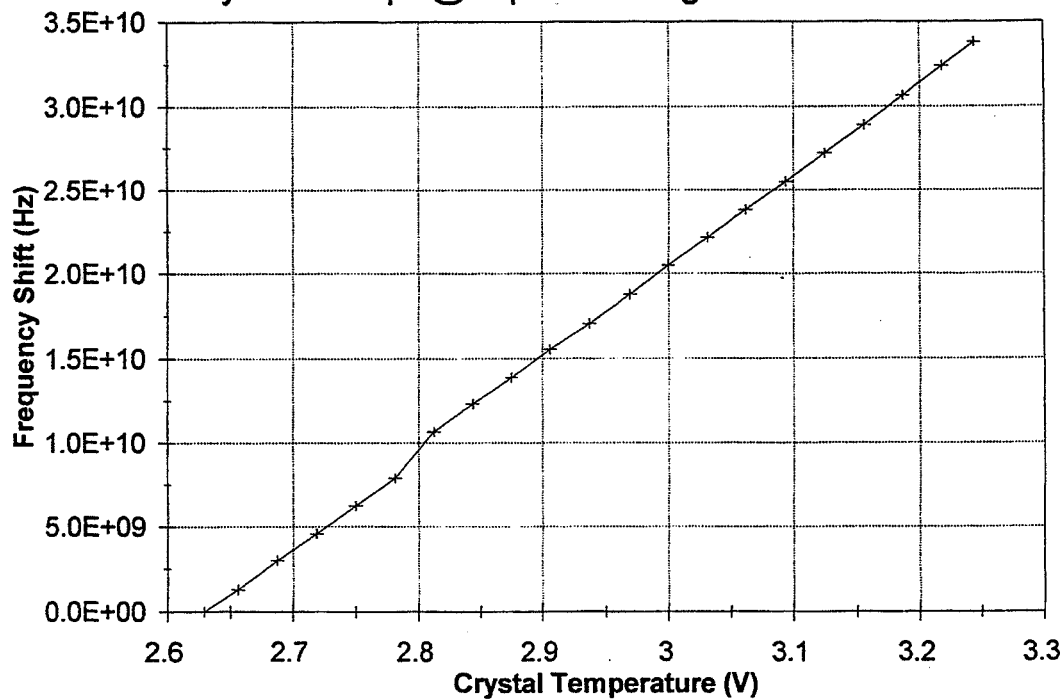

March 31, 1995

Fringe Position

Crystal Temp. @ 0 pin9 Voltage= 2.937V

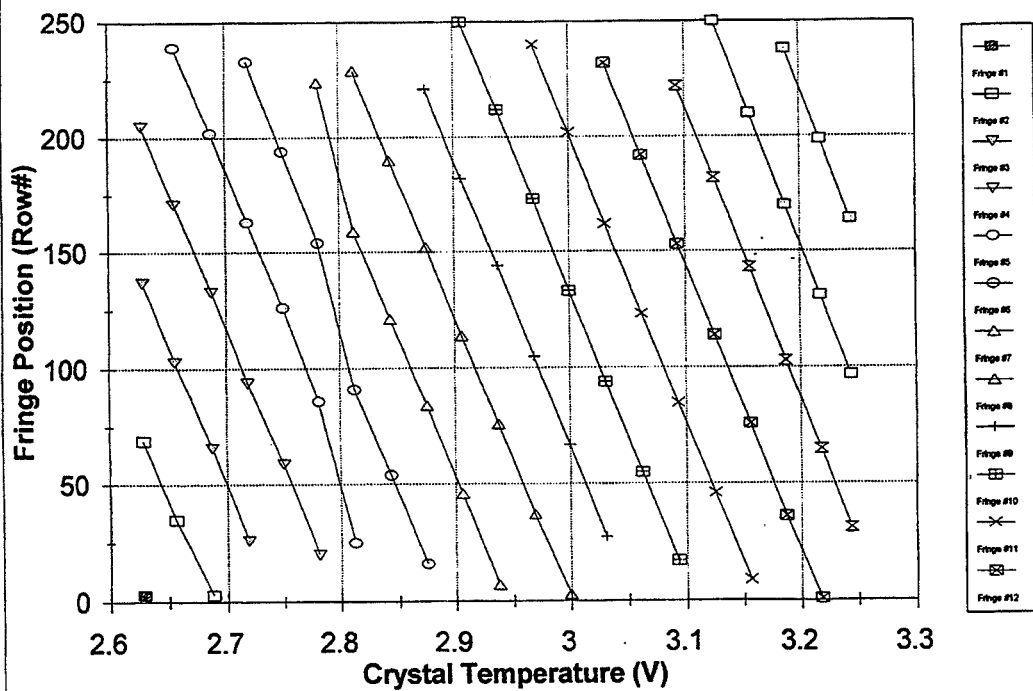

CONCLUSIONS

- o Nd:YAG based DLDR system provides improved temp./pressure measurements
- o The system may be limited to the condition: green background-to-signal > 3
- o This can be improved using TH along with FH of Nd:YAG
- o Slightly increased shot noise uncertainty with DLDR

- o Efforts continue to identify a viable candidate for uv (266 nm) filter

JET EVOLUTION VISUALIZED AND QUANTIFIED USING FILTERED RAYLEIGH SCATTERING

Mark F. Reeder
National Research Council Associate
NASA Lewis Research Center
Cleveland, Ohio

59-34

79381

032662

021

Filtered Rayleigh scattering was utilized as a flow diagnostic in an investigation of a method of enhancing mixing in supersonic jets. The experiments were performed at the Aeronautical and Astronautical Research Laboratory at The Ohio State University. The primary objectives of the study were to visualize the effect of vortex-generating tabs on supersonic jets, to extract quantitative data from these planar visualizations, and to detect the presence of secondary flows (i.e. streamwise vorticity) generated by the tabs. An injection seeded frequency-doubled Nd:YAG was the light source and a 14-bit Princeton Instruments ICCD camera was used to record the image through an iodine cell. The incident wavelength of the laser was held constant for each flow case so that the filter absorbed unwanted background light, but permitted part of the thermally broadened Rayleigh scattered light to pass through. The visualizations were performed for axisymmetric jets ($D=1.9\text{cm}$) operated at perfectly expanded conditions for Mach 1.0, 1.5, and 2.0. All data was recorded for the jet cross-section at $x/D=3$. One hundred instantaneous images were recorded and averaged for each case, with a threshold set to eliminate unavoidable particulate scattering. A key factor in these experiments was that the stagnation air was heated such that the expansion of the flow in the nozzle resulted in the static temperature in the jet being equal to the ambient temperature, assuming isentropic flow. Since the thermodynamic conditions of the flow were approximately the same for each case, the increases in the intensity recorded by the ICCD camera could be directly attributed to the Doppler shift, and hence velocity. Visualizations were performed for Mach 1.5 and Mach 2.0 jets with tabs inserted at the nozzle exit. The distortion of the jet was readily apparent and was consistent with Mie scattering-based visualizations. Asymmetry in the intensities of the images indicate the presence of secondary flow patterns which are consistent the streamwise vortices measured using more traditional diagnostics in subsonic jets with the same tab configurations. Because each tab causes shocks to form, the assumption of isentropic flow is not valid for these cases. However, within a reasonable first-order estimation, the intensity across the illuminated plane for these cases can be related to a value combining density and velocity.

Goals of this work

- ☞ To visualize the effect of tabs on supersonic jets using filtered Rayleigh scattering (FRS).
- ☞ To extract quantitative data from the planar FRS visualizations.
- ☞ To detect secondary flows (i.e. streamwise vorticity) generated by tabs in supersonic jets.

TABLE 2. Flow characteristics for the FRS experiments.

D (cm)	P ₀ (MPa) (absolute)	T ₀ (K)	M _j	T _j (K)	ρ _j (kg/m ³)	U _j (m/s)	Re _D (*10 ⁶)	ρ _j /ρ _∞	M _c
1.90	0.1879	335	1.0	279	1.24	335	0.667	1.02	0.50
1.90	0.3647	400	1.5	276	1.25	499	0.992	1.03	0.75
1.90	0.7721	500	2.0	278	1.24	667	1.31	1.02	1.00

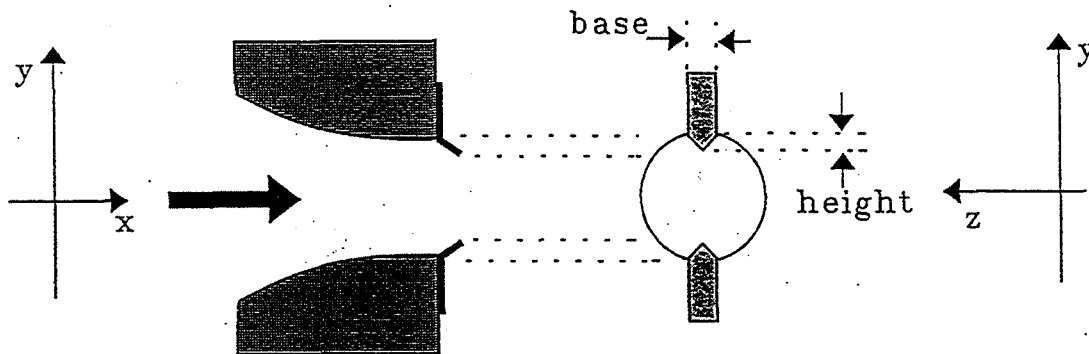

Figure 1. Sketch of a typical nozzle with two delta tabs. The base is $0.28D$ and the height is $0.10D$ for each tab.

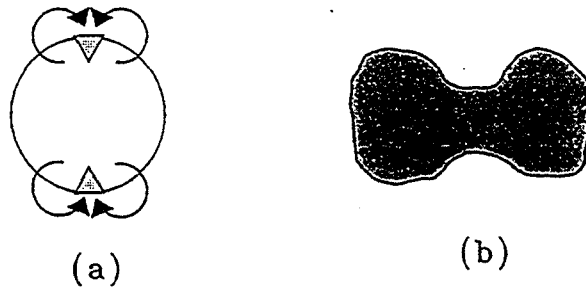

Figure 2. Sketch of (a) the direction of streamwise vortices generated by tabs, as measured in subsonic jets and (b) the resultant jet deformation caused by two delta tabs oriented as shown. [Zaman et. al. (1994)].

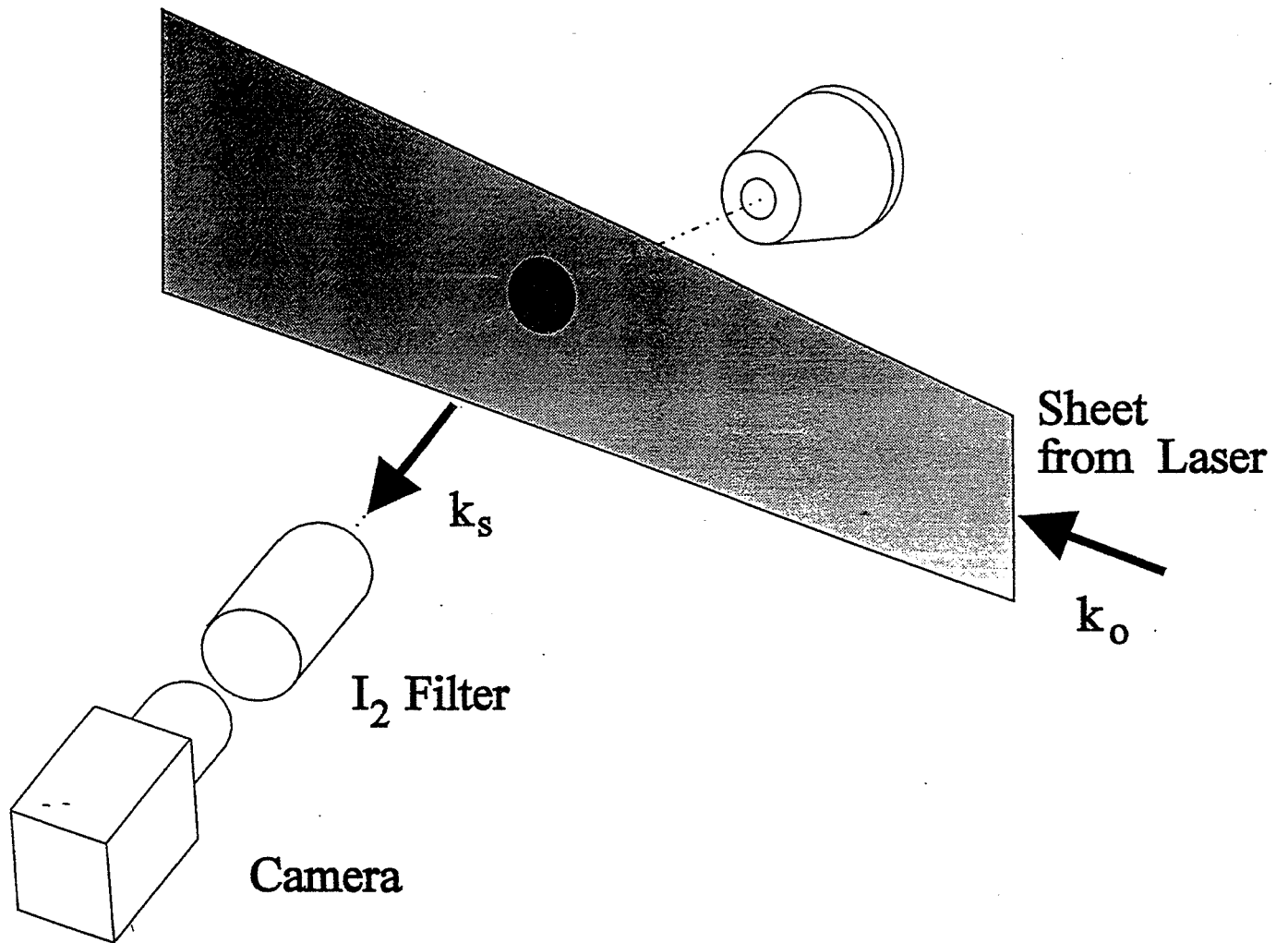

Figure 8. Sketch of the optical setup for the filtered Rayleigh scattering measurements in supersonic jets. The filter contains diatomic iodine in a gaseous state.

Density from unfiltered Rayleigh scattering may be described:

$$I = \rho \int_{f_{min}}^{f_{max}} R^*(f) df \quad (1)$$

With a filter of known profile P_{filter} in the ambient air, where the directional velocity is zero:

$$I_{\infty} = \rho_{\infty} \int_{f_{min}}^{f_{max}} [R^*(f_0, \rho_{\infty}, T_{\infty}, \theta)] [P_{filter}(f_0)] df \quad (2)$$

Due to the Doppler effect:

$$\Delta f = \frac{\bar{V}}{\lambda} \cdot (\bar{k}_s - \bar{k}_o) \quad (3)$$

and hence, in the jet core:

$$I = \rho \int_{f_{min}}^{f_{max}} [R^*(f_0 + \Delta f, \rho, T, \theta)] [P_{filter}(f_0)] df \quad (4)$$

If the density and temperature are assumed constant across the visualized plane, then:

$$\rho^* = \frac{\rho}{\rho_{\infty}} = 1.0 \quad (5)$$

$$\frac{I}{I_{\infty}}(\Delta f) = \frac{\int_{f_{min}}^{f_{max}} R^*(f + \Delta f) P_{filter}(f) df}{\int_{f_{min}}^{f_{max}} R^*(f) P_{filter}(f) df} \quad (6)$$

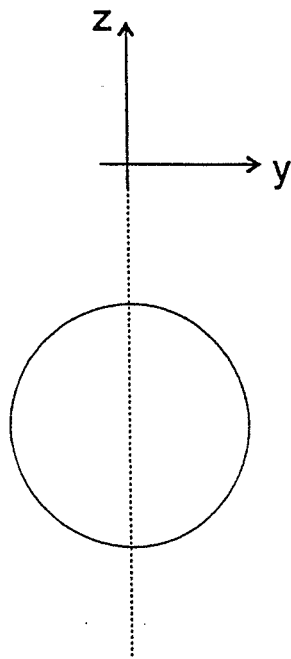

Assume: $U(y) = U(-y)$
 $V(y) = -V(-y)$
 $\rho(y, z) = \text{constant}$
 $T(y, z) = \text{constant}$

To obtain velocity data from a single averaged FRS image of a jet without tabs, the above assumptions were made.

Spectral Characteristics For the filter and ambient Rayleigh scattering

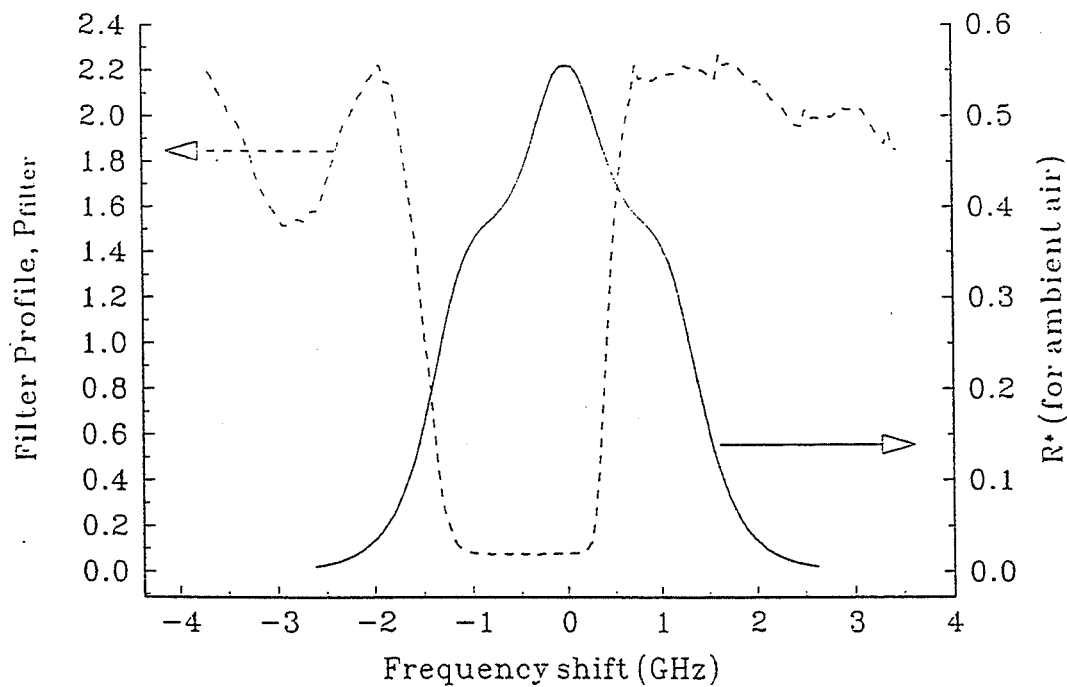

Figure 9. Spectral characteristics of the optical filter (dashed line) and the ambient scattering media (solid line). Zero frequency shift refers to the incident laser frequency.

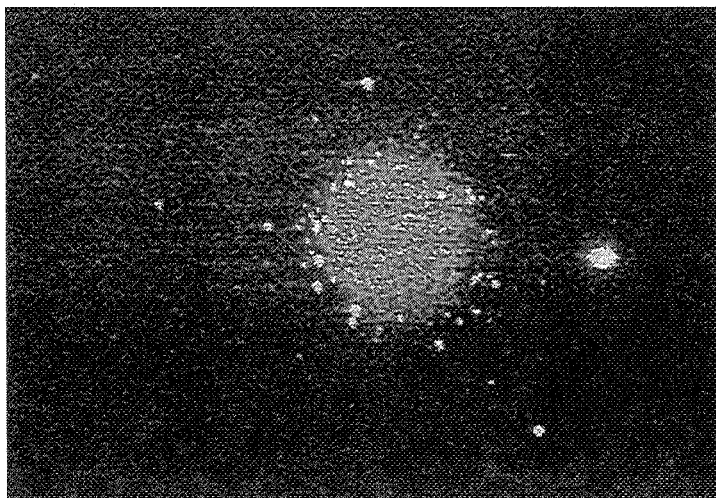
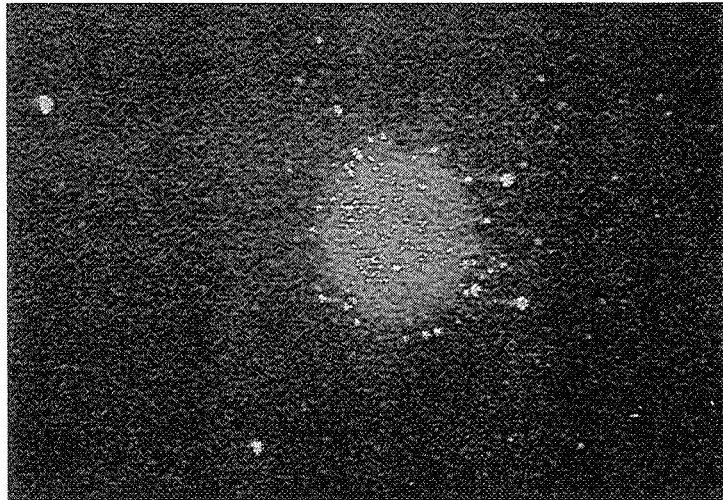
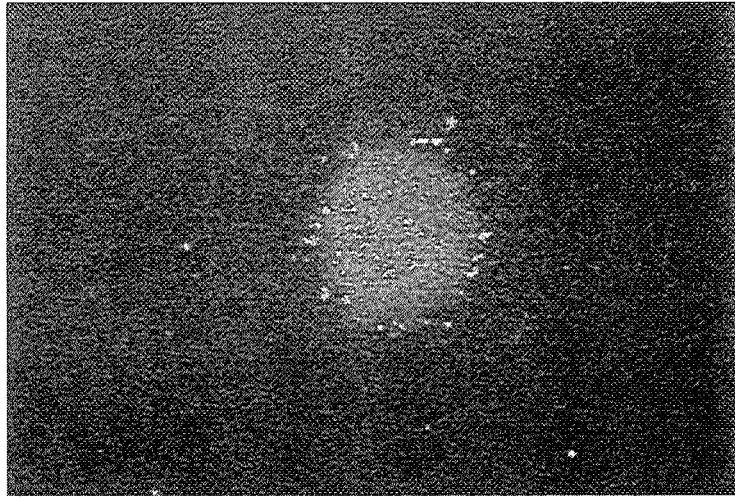

Figure 10. Three typical instantaneous filtered Rayleigh scattering images of a perfectly expanded, isothermal Mach 2 jet without tabs.

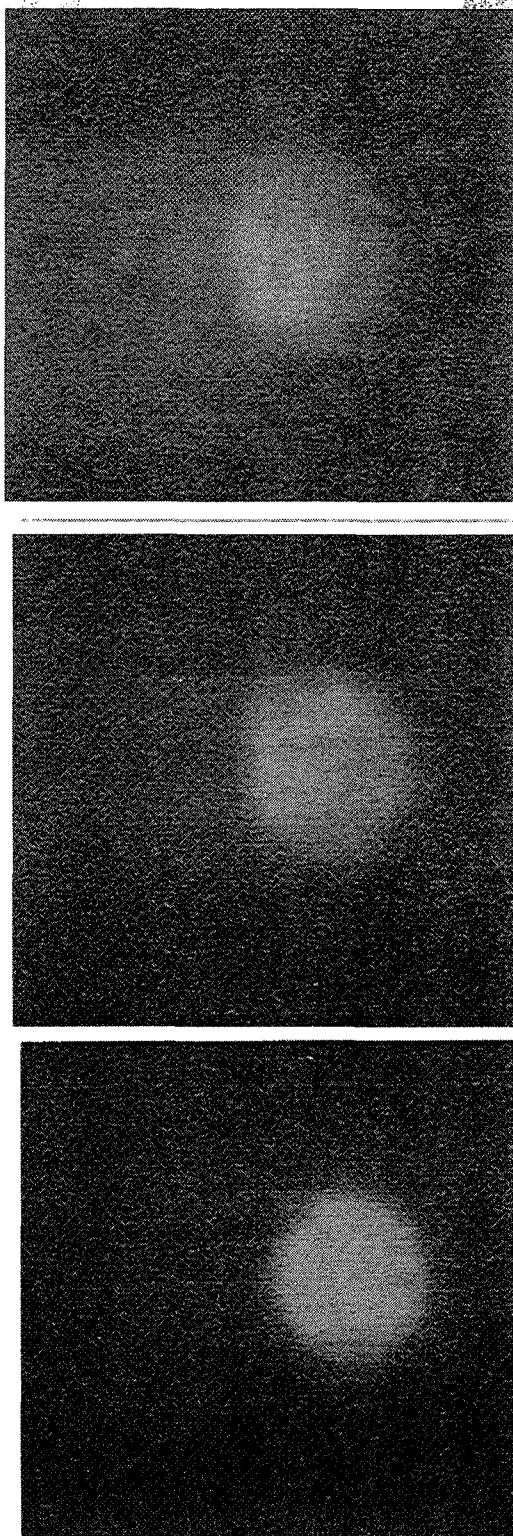

Figure 11. Post-processed, average images of filtered Rayleigh scattering for perfectly expanded, isothermal (a) Mach 1.0, (b) Mach 1.5, and (c) Mach 2.0 jets without tabs taken at $x/D=3$ for each case.

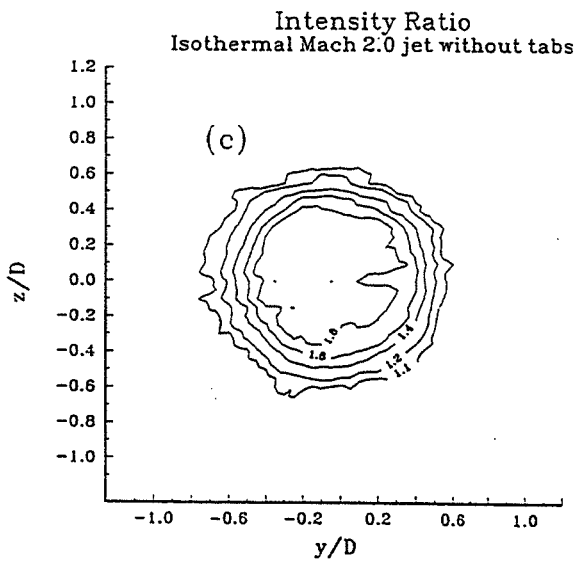
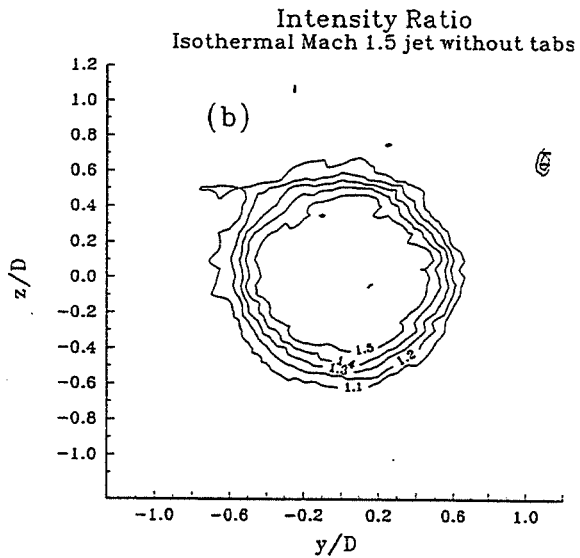
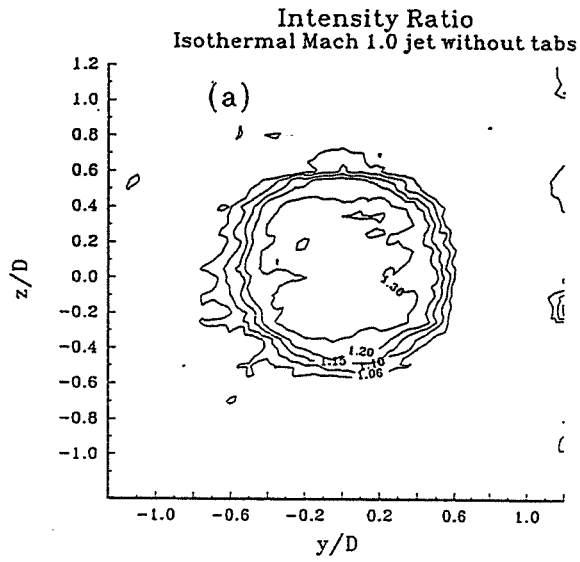
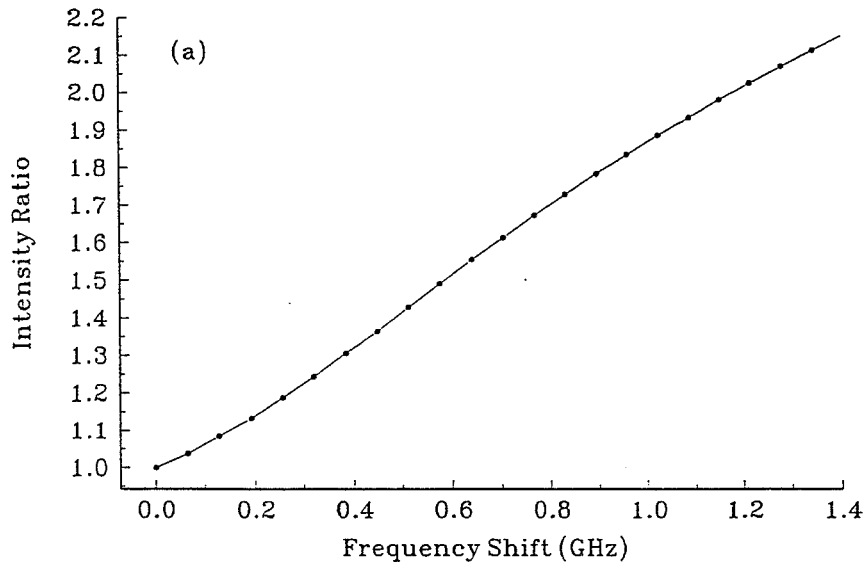

Figure 12. Intensity ratios from FRS for isothermal jets without tabs for (a) Mach 1.0, (b) Mach 1.5, and (c) Mach 2.0.

Intensity Ratio as a Function of Frequency Shift
For isothermal no-tab cases



Frequency Shift as a Function of Intensity Ratio
For isothermal no-tab cases

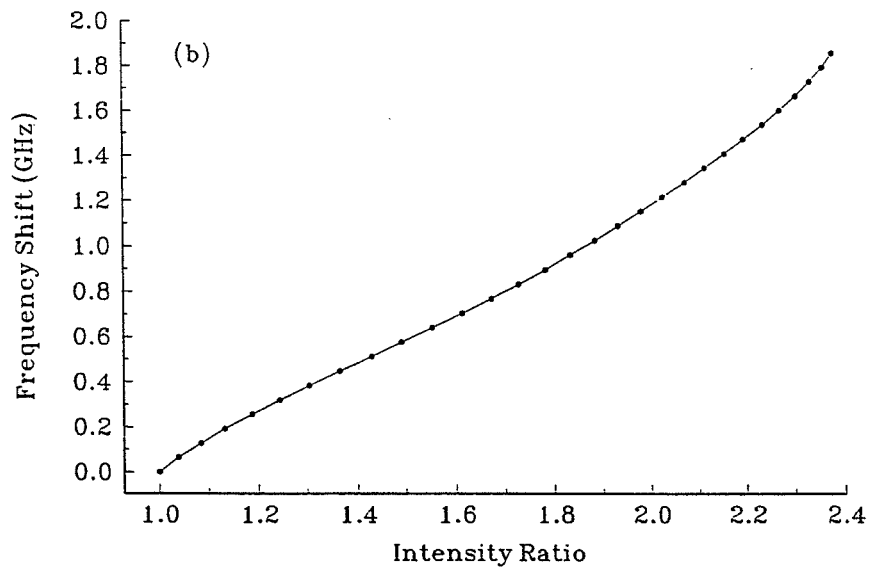

Figure 13. Relationship between intensity ratio and velocity for jets without tabs. In (a) the intensity ratio is calculated as a function of frequency shift for the given Rayleigh scattering spectra. This is then used for calibration to find velocities, shown in (b) for clarity.

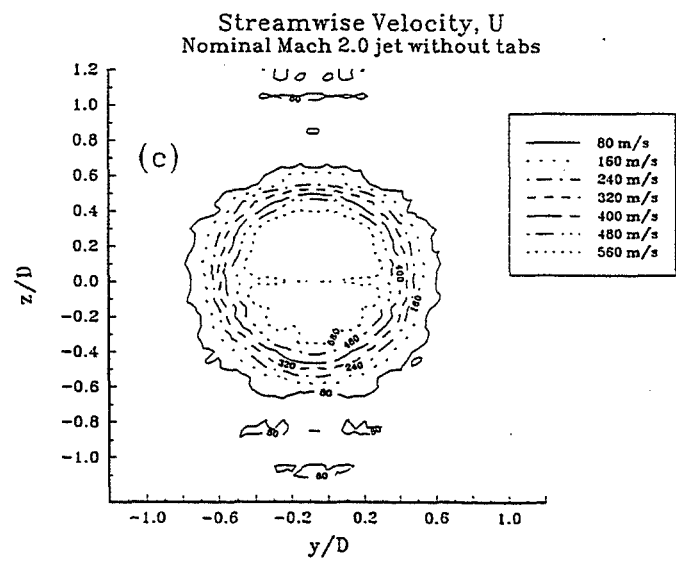
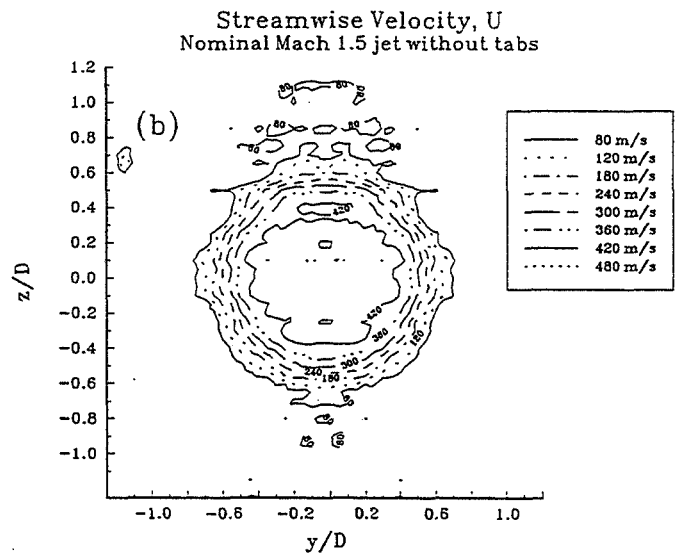
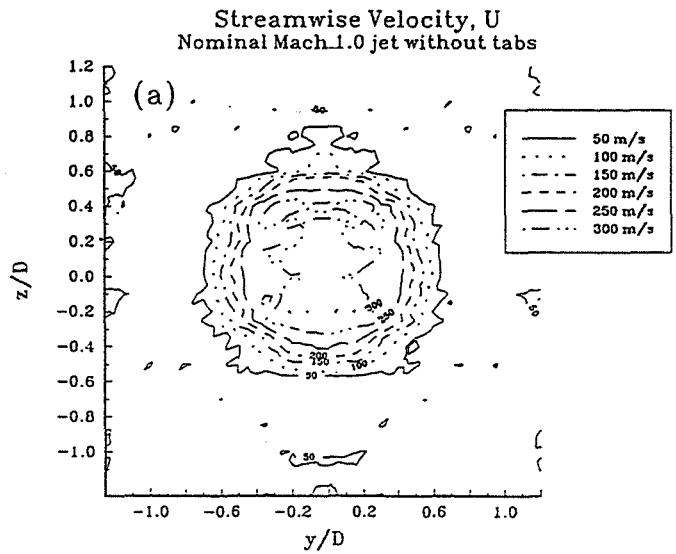
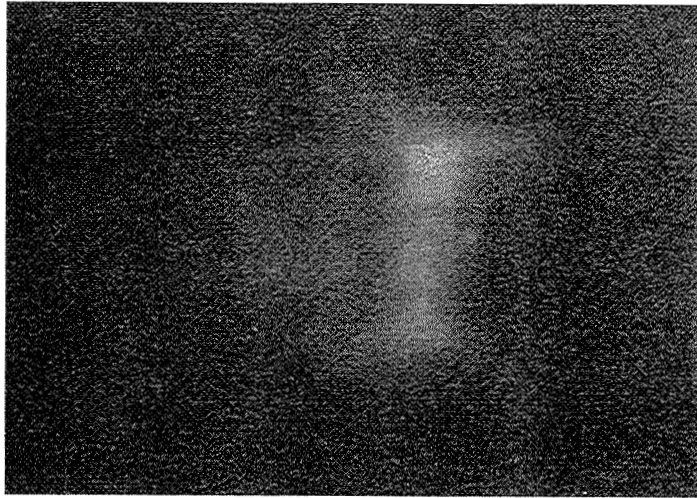
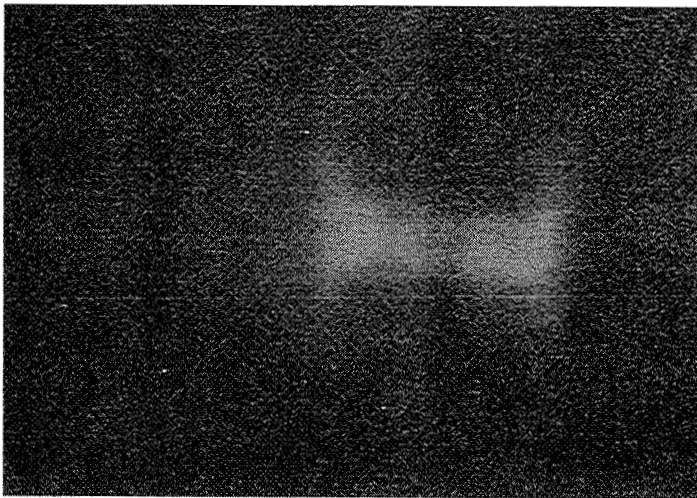
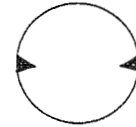

Figure 14. Streamwise velocity contours from FRS for isothermal jets without tabs for (a) Mach 1.0, (b) Mach 1.5, and (c) Mach 2.0.



(a)



(b)

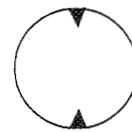

Figure 15. Post-processed average filtered Rayleigh scattering images of a Mach 1.5 jet with two delta tabs. In (a) the tabs are along the horizontal axis, and in (b) the tabs are along the vertical axis.

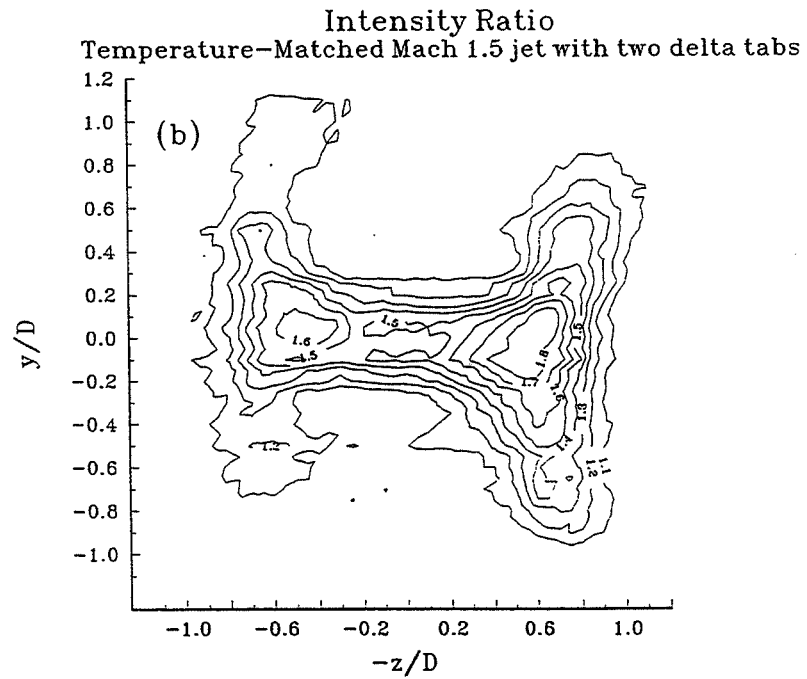
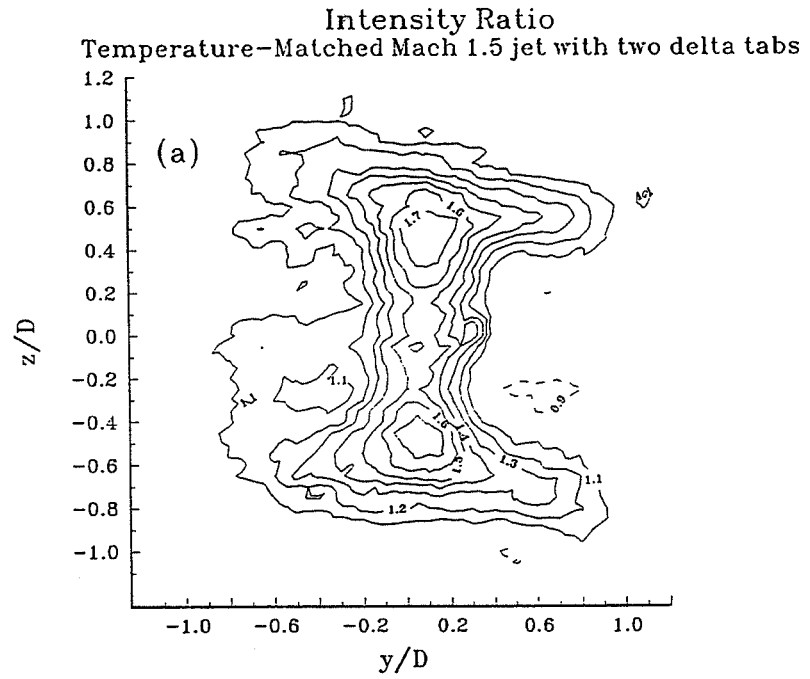
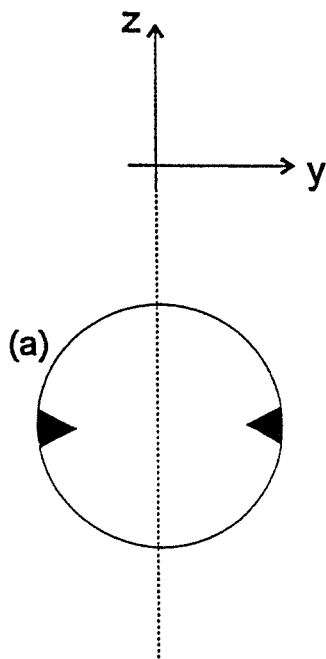
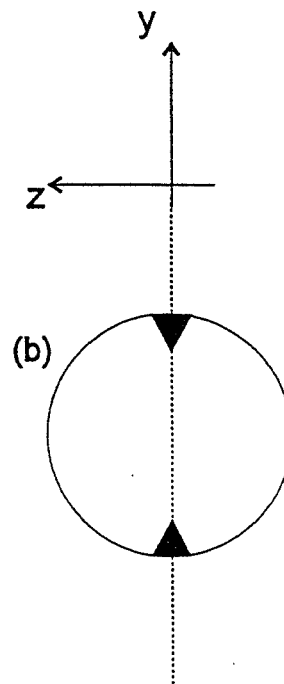

Figure 16. Intensity ratios for temperature-matched Mach 1.5 jets. Tab orientation corresponds directly to Fig. 15.



Assume: $U(y) = U(-y)$
 $V(y) = -V(-y)$
 $\rho(y) = \rho(-y)$
 $T(y) = T(-y)$



Assume: $U(z) = U(-z)$
 $W(z) = -W(-z)$
 $\rho(z) = \rho(-z)$
 $T(z) = T(-z)$

To obtain quantitative data from a single averaged FRS image for a jet with two delta tabs, the above assumptions were made for the respective cases.

How can the intensity ratios be related to properties of the jet with tabs?

$$\frac{I}{I_{\infty}} = \frac{\rho}{\rho_{\infty}} * D[(k_s - k_o) \cdot \bar{V}] * E\left(\frac{\rho}{\rho_{\infty}}, \frac{T}{T_{\infty}}, \bar{V}\right) \quad (5)$$

The function term D is associated with the Doppler shift. The term E accounts for variations in the shape of the Rayleigh scattering signal.

Assuming only minor effects to changes in the scattering profile (i.e. E=1.0) and assuming symmetry, tab configuration (a) yields:

$$\left(\frac{I}{I_{\infty}}\right)_{y>0} + \left(\frac{I}{I_{\infty}}\right)_{y<0} = \rho^* * \left[2 + 1.82 * f(U)\right] \quad (7)$$

$$\left(\frac{I}{I_{\infty}}\right)_{y>0} - \left(\frac{I}{I_{\infty}}\right)_{y<0} = \rho^* * \left[2.82 * f(V)\right] \quad (8)$$

and tab configuration (b) yields:

$$\left(\frac{I}{I_{\infty}}\right)_{z>0} + \left(\frac{I}{I_{\infty}}\right)_{z<0} = \rho^* * \left[2 + 1.82 * f(U)\right] \quad (9)$$

$$\left(\frac{I}{I_{\infty}}\right)_{z>0} - \left(\frac{I}{I_{\infty}}\right)_{z<0} = \rho^* * \left[2.82 * f(W)\right] \quad (10)$$

with f(U), f(V) and f(W) being taken from linear approximations of frequency (and hence velocity) vs. intensity ratio.

Scattering Half-Profiles For Constant Light Vector

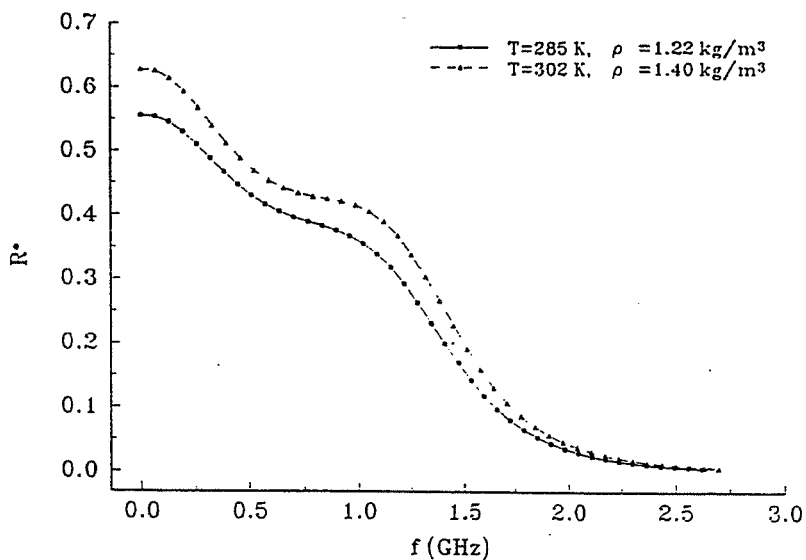

Figure 17. Comparison of the scattering half-profiles for air of the two thermodynamic states indicated. The higher density and temperature condition is reasoned to be "worst-case" for the Mach 1.5 delta tab case.

$\rho^*\{1+f(U)\}$ comparison Error estimation for Mach 1.5 delta tab cases

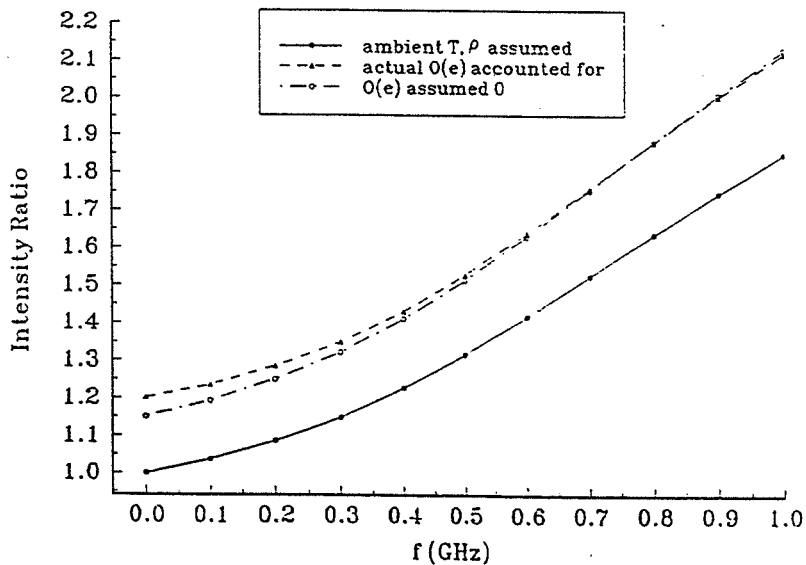

Figure 18. Assessment of the applicability of Eqn. 8 to the intensity ratio for the Mach 1.5 delta tab case.

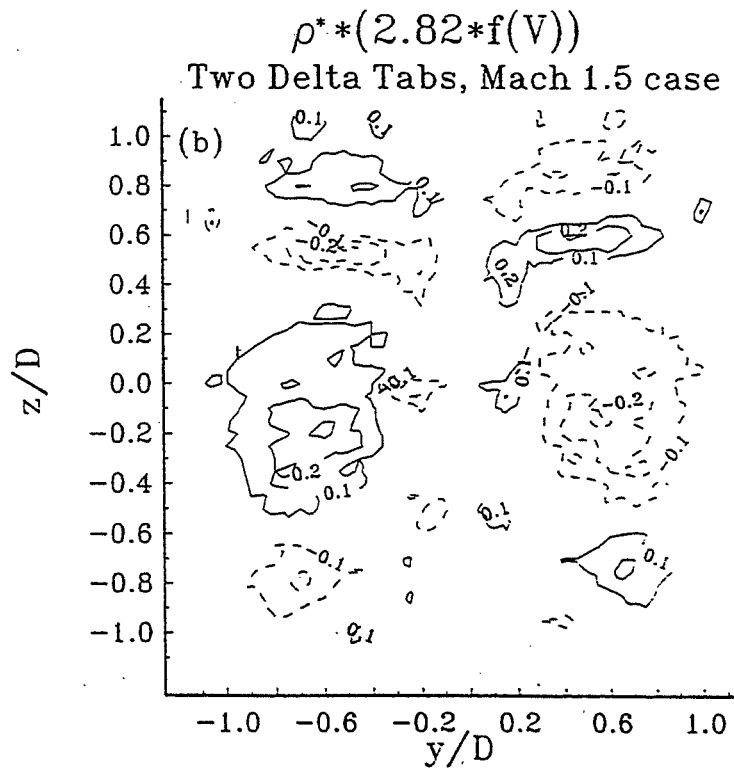
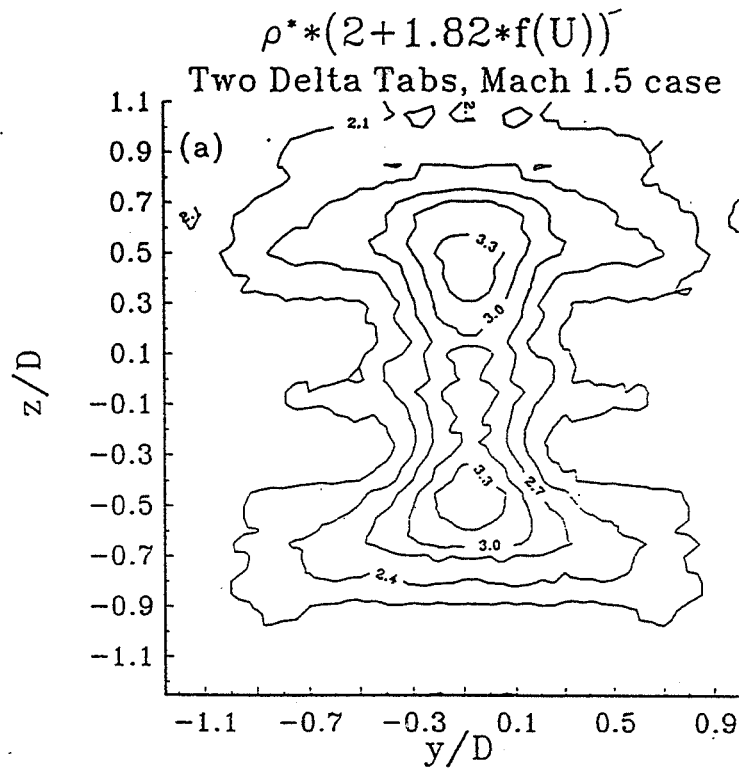
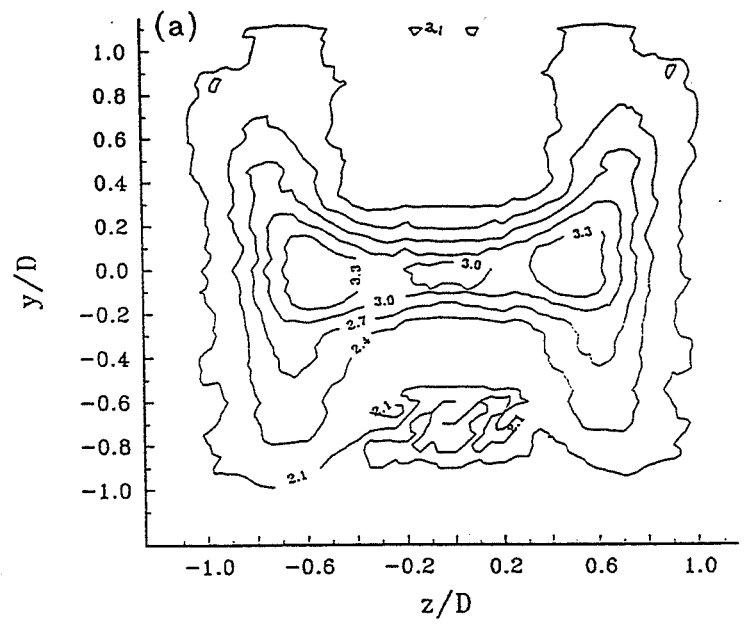

Figure 19. Quantitative values from FRS for a temperature-matched Mach 1.5 jet with two delta tabs. Tabs were placed along the y-axis.

$\rho^*(2+1.82*f(U))$
Two Delta Tabs, Mach 1.5 case



$\rho^*(2.82*f(W))$
Two delta tabs, Mach 1.5 case

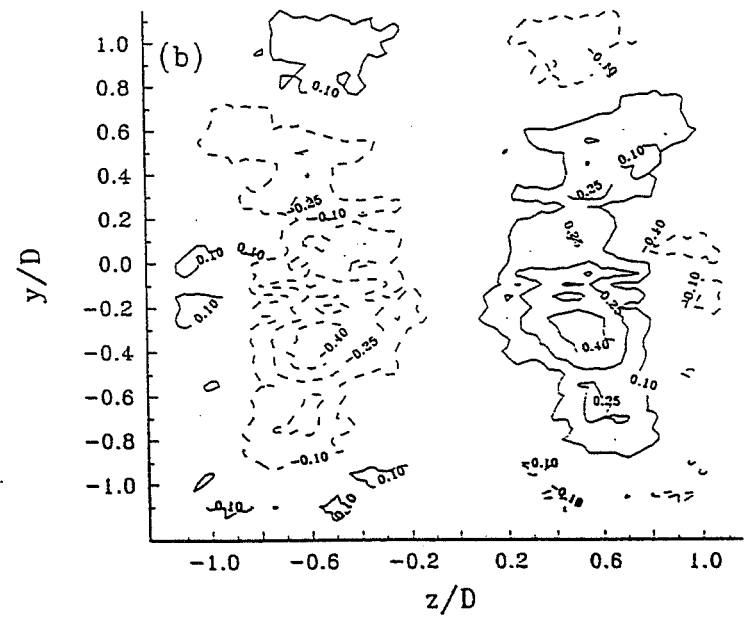
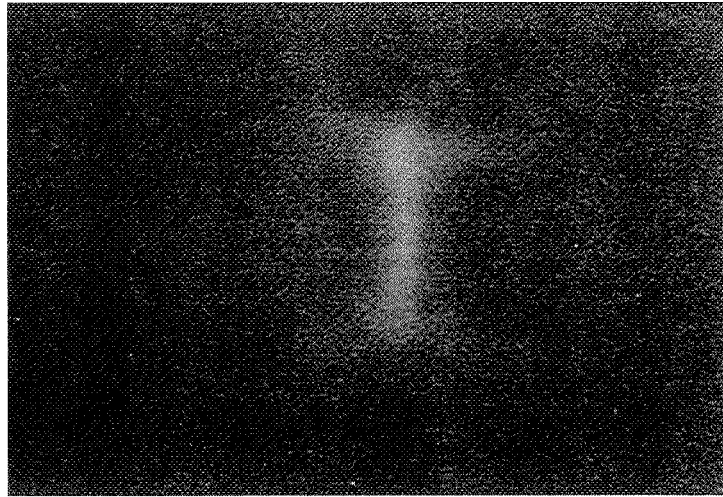
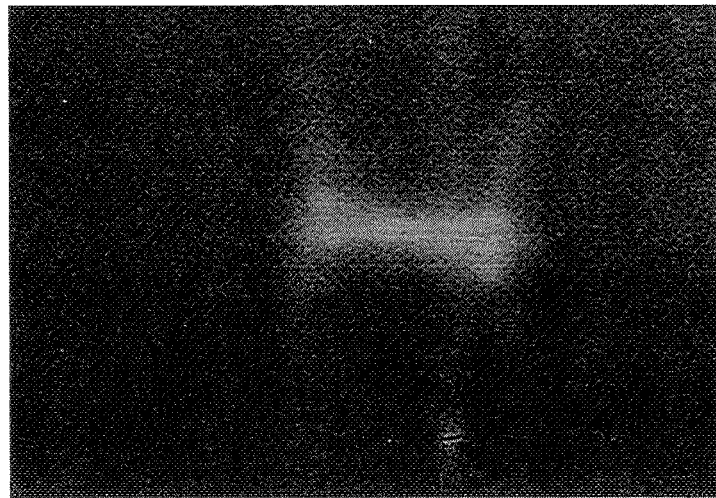
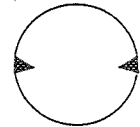

Figure 20. Quantitative values from FRS for a temperature-matched Mach 1.5 jet with two delta tabs. Tabs were placed along the y-axis.



(a)



(b)

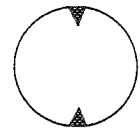

Figure 21. Post-processed average filtered Rayleigh scattering images of a Mach 2.0 jet with two delta tabs. In (a) the tabs are along the horizontal axis, and in (b) the tabs are along the vertical axis.

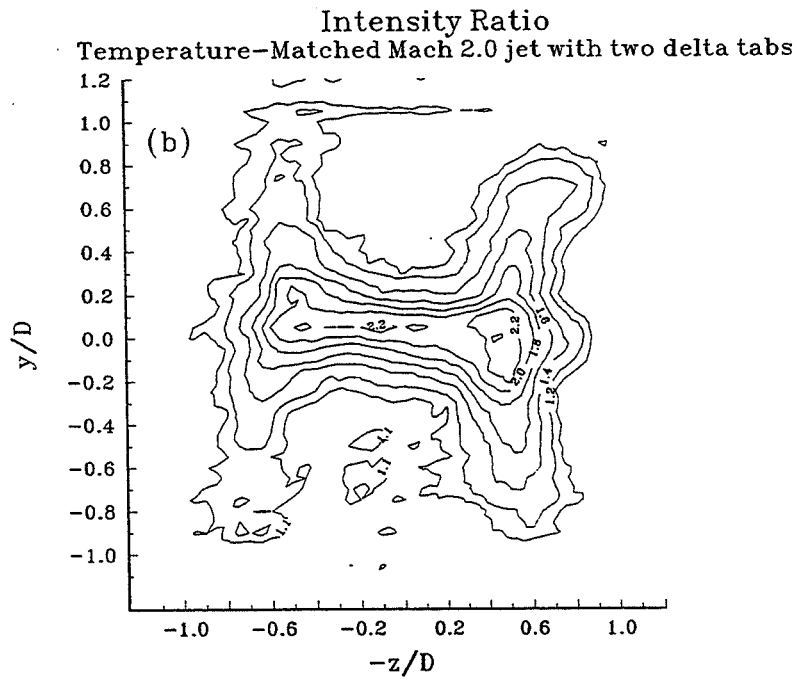
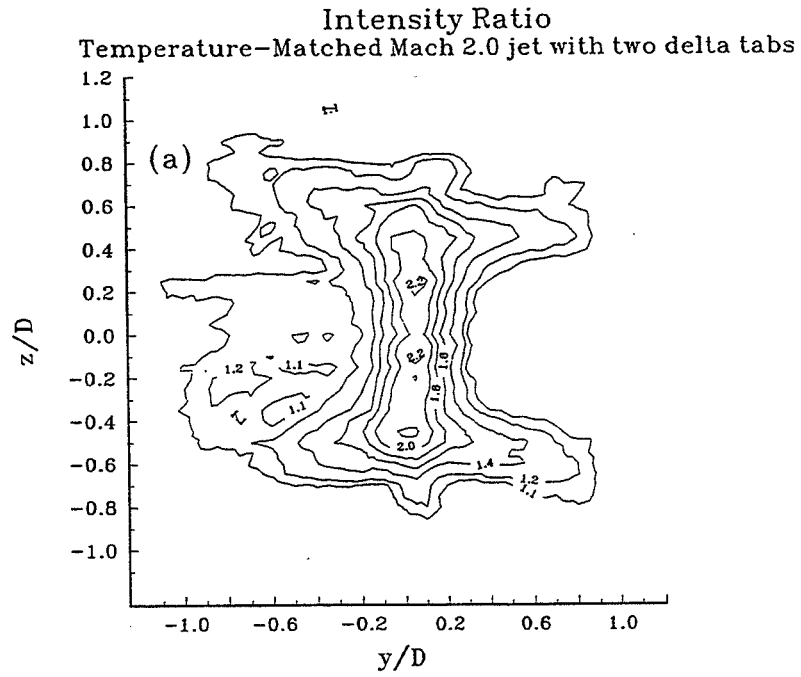

Figure 22. Intensity ratios for temperature-matched Mach 2.0 jets. Tab orientation corresponds directly to Fig. 21.

RAYLEIGH SCATTERING MEASUREMENTS IN NASA LEWIS WIND TUNNELS

CLOSE

Richard Seasholtz
NASA Lewis Research Center
Cleveland, Ohio

510-34

79382

050664

6P

ABSTRACT

Two applications of Rayleigh scattering for measurement of flow parameters in wind tunnels are described. The first is the measurement of one velocity component and static temperature in the vicinity of a 12 % scale ASTOVL aircraft model in the Lewis 9 ft by 15 ft low speed wind tunnel¹. The model was equipped with high temperature and high pressure air supplies to simulate lift nozzles and suction systems to simulate engine inlets. Light from a single frequency argon-ion laser was transmitted through a 140 m long multimode optical fiber to the test section and focused to a 1 mm x 4 mm probe volume coincident with a two-color LDV system probe volume. Data were obtained in two phases. In the first phase, measurements were made primarily to obtain gas temperature in the vicinity of the model. No seeding was used and LDV measurements were not taken. In the second phase, PSL seeding was used and Rayleigh data were obtained simultaneously with the LDV data. The Rayleigh measurements gave spanwise velocity and temperature. For these measurements, the nozzles were operated at less than their design temperature to avoid destroying the PSL seed. A significant observation was that the Rayleigh scattering measurements could be obtained even with the flow being seeded for the LDV measurements. This was possible because the spectral width of the Mie scattering was much narrower than the thermally broadened molecular Rayleigh scattered light. The estimated accuracy of the Rayleigh measurements was 10 m/s for velocity and 5 % for temperature.

The second application is feasibility study to measure flow properties in a 4 inch by 10 inch supersonic wind tunnel². This technique uses an injection seeded, frequency doubled Nd:YAG laser tuned to an absorption band of iodine. The laser beam was transmitted through a window in the tunnel roof and directed upstream by a mirror located near the second throat. Rayleigh scattered light was collected through a window in the side wall and filtered with an iodine cell to block light at the laser frequency. The Doppler-shifted Rayleigh scattered light that passed through the iodine cell was analyzed with a planar mirror Fabry-Perot interferometer used in a static imaging mode. An intensified CCD camera was used to record the images. The images were analyzed at several subregions, where the flow velocity was determined. Each image was obtained with a single laser pulse, giving instantaneous measurements. For proper modeling of the iodine filter transmission, it was necessary to measure the YAG laser frequency simultaneously with the measurement of the Rayleigh scattered light. This was done using a frequency stabilized helium neon laser as a reference. Problems in maintaining beam pointing direction and Fabry-Perot interferometer alignment were caused by the high acoustic noise levels in the test cell at higher mass flow rates. The velocity accuracy for single pulse measurements was estimated to be about 10 %, although some of this variation may have been due to flow fluctuations.

1. H.E. Kourous and R.G. Seasholtz, "Fabry-Perot interferometer measurement of static temperature and velocity for ASTOVL model tests", *Laser Anemometry 1994, Advances and Applications*, ASME FED-Vol. 191, pp. 65-70.

2. R.G. Seasholtz, A.E. Buggele, and M.F. Reeder, "Instantaneous flow measurements in a supersonic wind tunnel using spectrally resolved Rayleigh scattering", *SPIE Proceedings on Optical Techniques in Fluid, Thermal, and Combustion Flow*, vol. 2546, 1995.

9 FT BY 15 FT LOW SPEED WIND TUNNEL

- Temperature and velocity measurements for ASTOVL HGI Study
- Scanning Fabry-Perot interferometer (time average measurements)
- Used with LDV to get 3 velocity components and temperature
- Long working distance (2.2 m)
- High particle loading in measurement volume (both ambient and seeded flow)
- Stray laser light not a problem
- Argon-ion laser (488/476 nm) coupled through long multimode fiber (140 m)
- Scattered light transmitted by optical fiber to "quiet" room containing Fabry-Perot
- Estimated accuracy was 10 m/sec for measured velocity component and 5 % for temperature

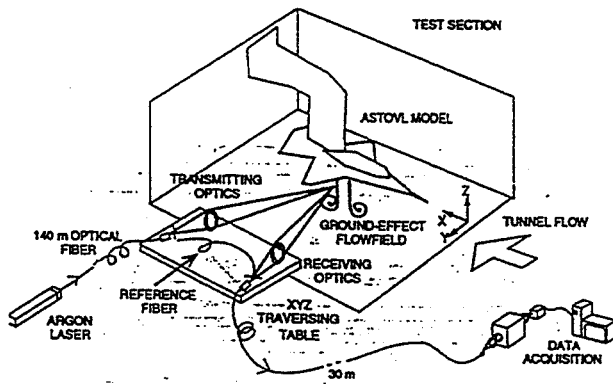

Optical configuration schematic showing wind tunnel test section, scale aircraft model, source laser, optical fibers, reference fiber, traversing table, Fabry-Perot interferometer, and data acquisition system.

HGI 9 x 15: Rayleigh Spectral Checkout Data

X = Forward Nozzle long. CL (constant)
 Y was increased from model CL toward wall
 Z = 17.5" from GP (Constant)

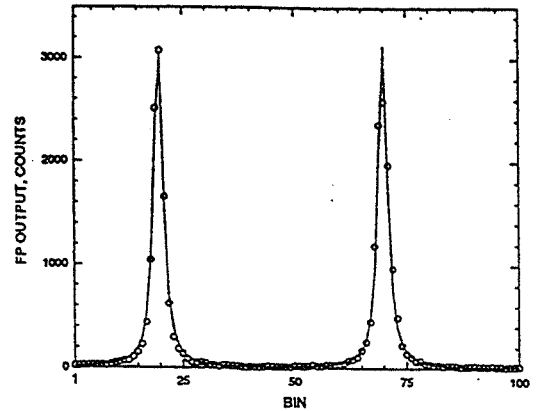
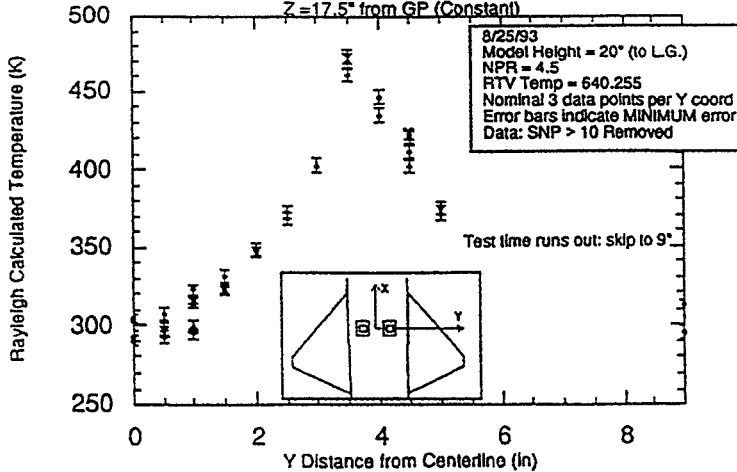

a)

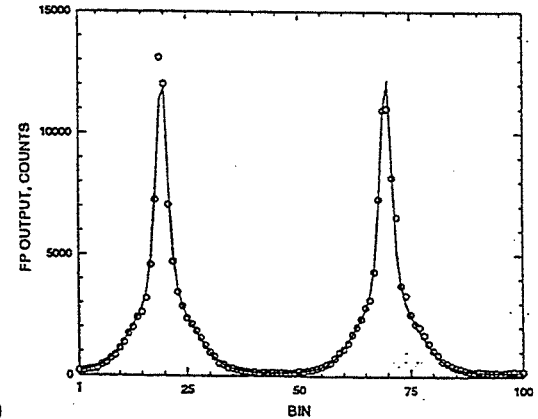

b)

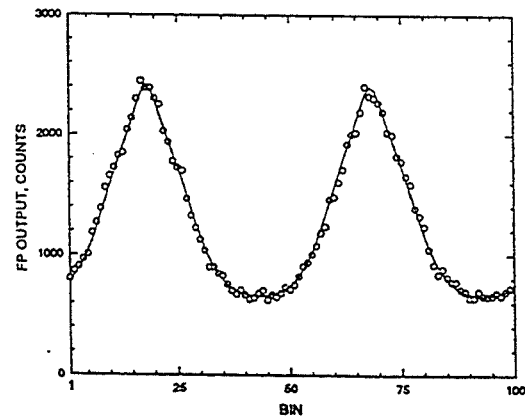

c)

Spectra acquired by the Fabry-Perot interferometer: a) measured instrument function; b) a Mie-dominated seeded-flow spectrum; and c) a high temperature Rayleigh-dominated spectrum in unseeded flow.

Fabry-Perot interferometer

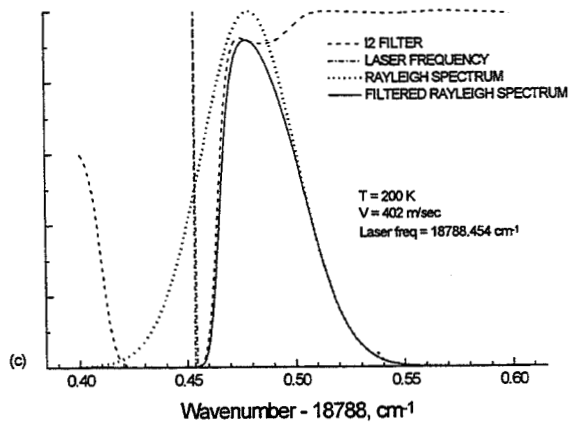
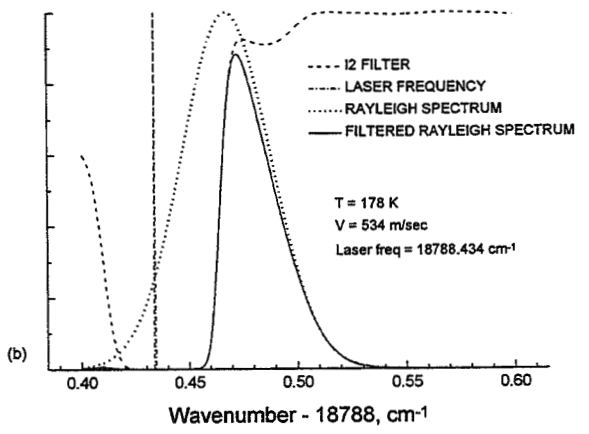
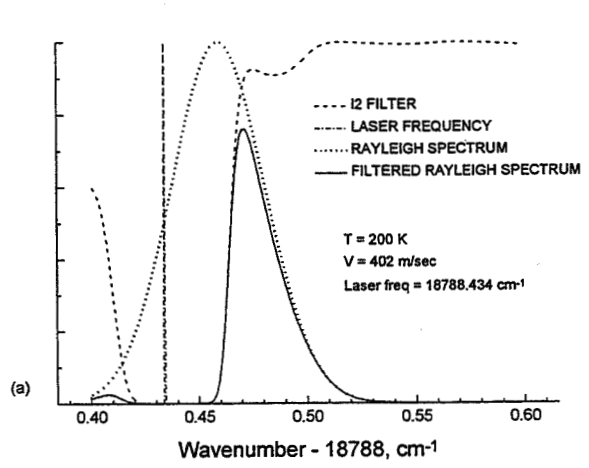
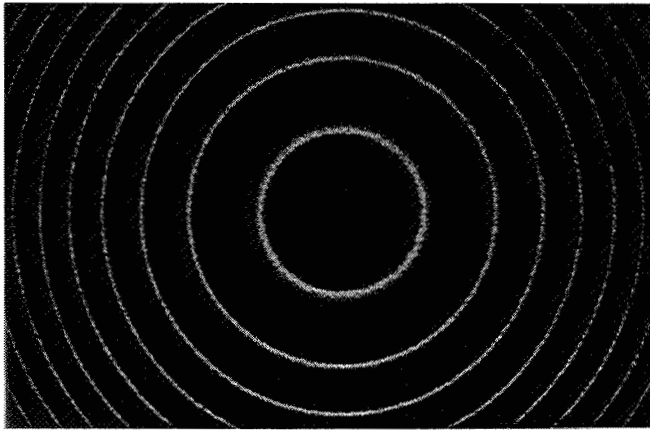
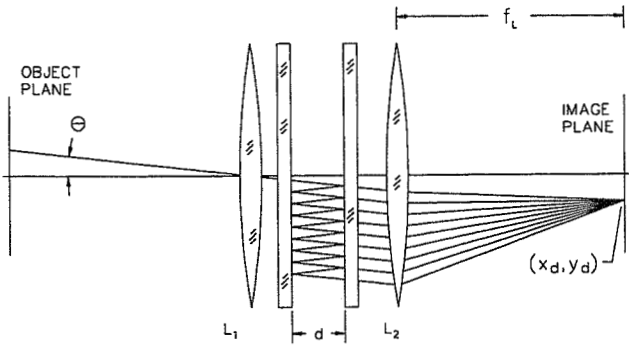

FILTERED RAYLEIGH SCATTERING

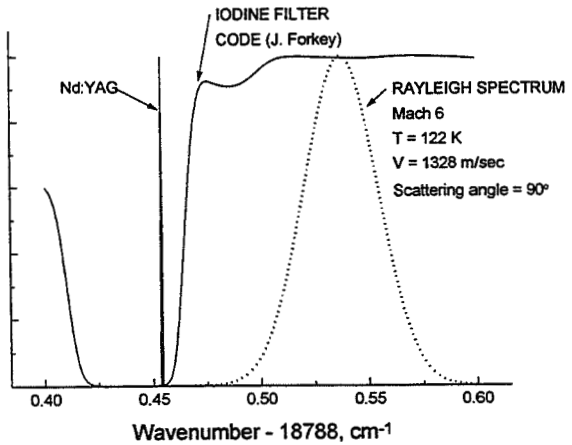

MODEL FUNCTION FOR FILTERED RAYLEIGH SCATTERING

$$\langle N_{Dq} \rangle = \int \int \int_{\Omega, \Delta, -\infty}^{\infty} [A_R S_R(f, \Omega) + A_W \delta(f - f_0)] I_{FP}(f, \theta, \cdot) I_{I2}(f) df dA d\Omega + B_q$$

- A_R - Rayleigh intensity
- S_R - Rayleigh spectrum
- I_{FP} - Fabry-Perot instrument function
- I_{I2} - iodine filter transmission function
- A_W - stray laser light intensity
- B_q - broadband noise

Integration is over frequency, pixel area, and collection angle

(a-b) Filtered Rayleigh scattering spectra for two flow conditions with the laser frequency equal 18788.434 cm⁻¹ ; (c) spectrum for same flow condition as (a) with a laser frequency of 18788.454 cm⁻¹

4 INCH BY 10 INCH SUPERSONIC WIND TUNNEL (DUCT LAB)

- Instantaneous multipoint velocity measurements at about Mach 1.5
- Injected-seeded Nd:YAG laser (532 nm)
- Fabry-Perot used in static, imaging mode
- Few particles in flow (air filtered)
- Large amount of stray laser light
- Used iodine absorption cell
- Problems with vibration of Fabry-Perot at higher mass flow rates
- Assumption of adiabatic flow is used in data reduction, so independent temperature measurement was not obtained
- Estimated accuracy was 10 %

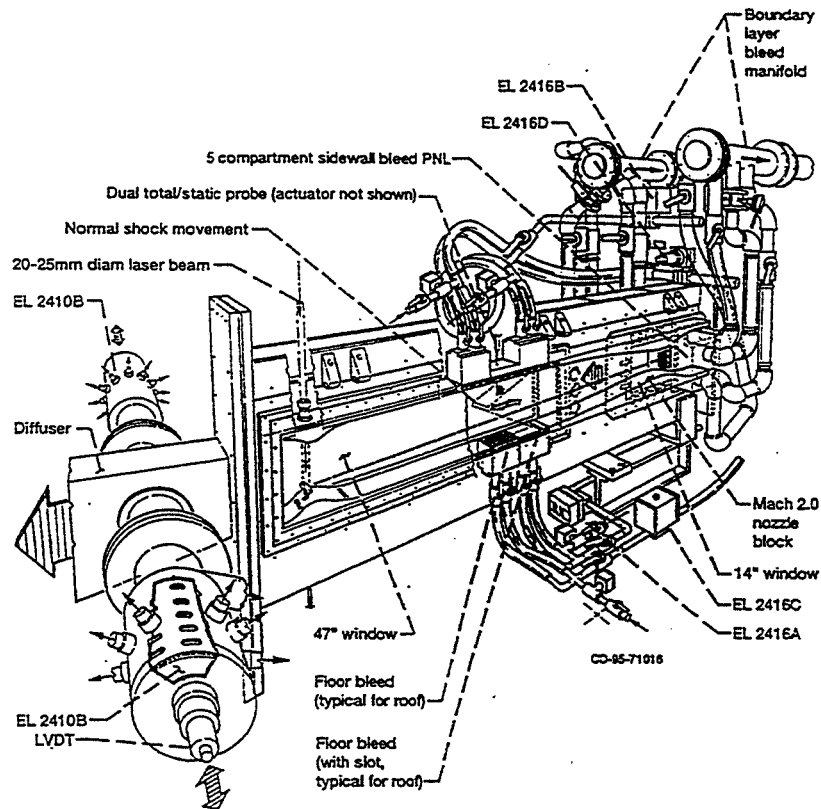

Supersonic Wind Tunnel (SWT) with shock shape position controls.

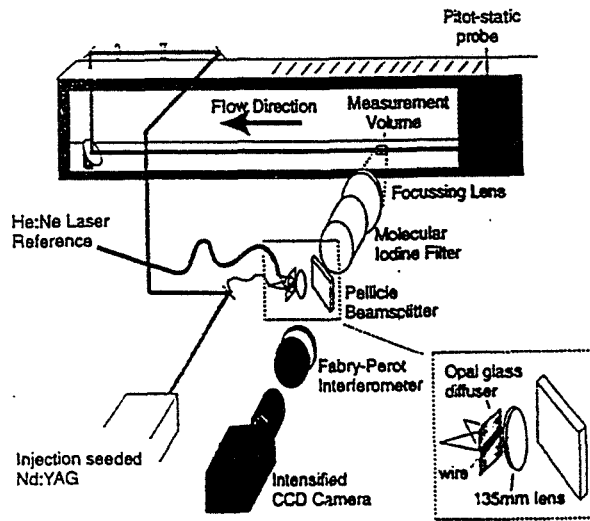

Optical arrangement for the Rayleigh scattering measurements.

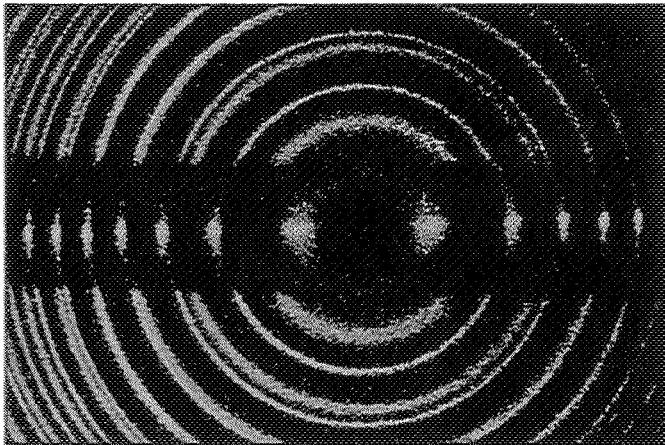

(a)

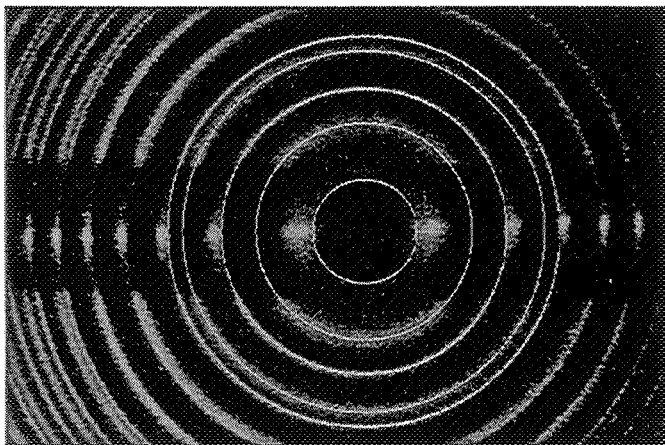

(b)

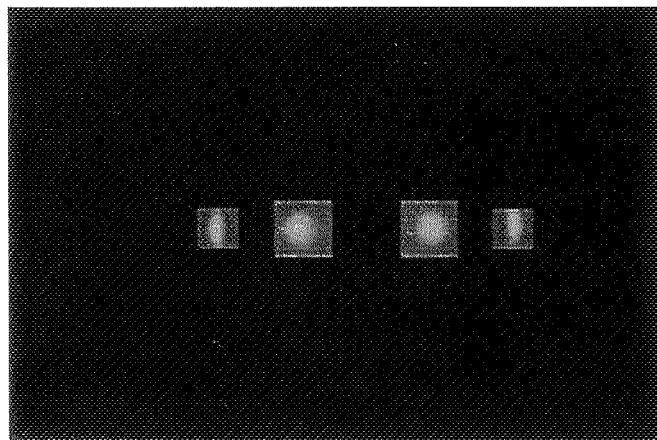

(c)

(a) Image showing Nd:YAG and HeNe reference fringes in upper and lower parts with Rayleigh scattered light in center; (b) image showing fit to Nd:YAG and HeNe reference fringes; (c) fit to model function for four subregions.

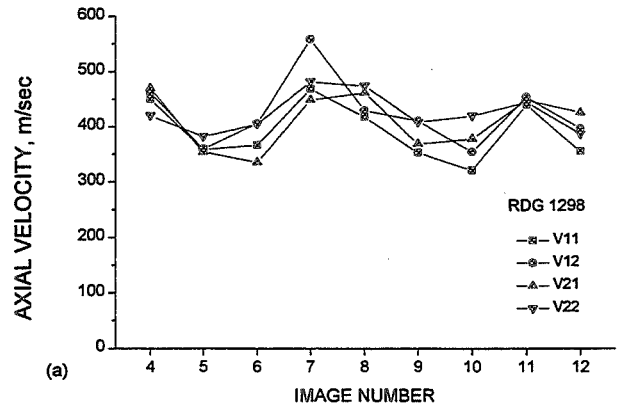

(a)

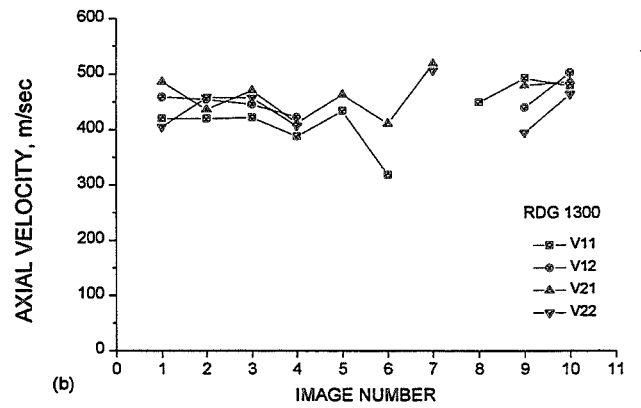

(b)

Axial velocity for number of images for two flow condition: (a) RDG 1298 (b) RDG 1300. Each image is from single laser pulse with velocity determined for four subregions; gaps are result of lack of convergence for certain subregions.

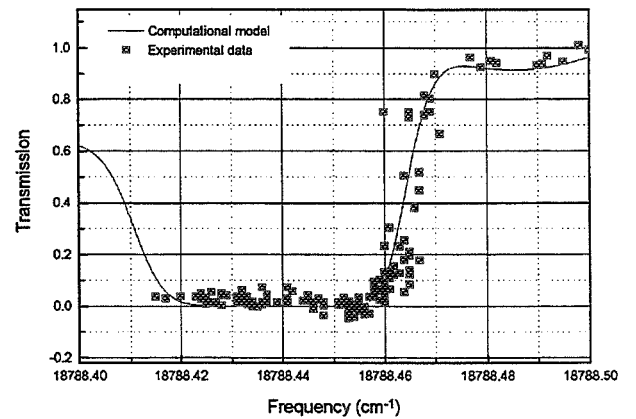

Transmission of Nd:YAG light through iodine cell

omit to
END

TRANSCRIPTION OF PANEL DISCUSSIONS

Panel discussion 1

Assessment of potential applications of Rayleigh scattering diagnostics

Panel Members

Wim DeGroot, NYMA, NASA Lewis Research Center
Al Johns, NASA Lewis Research Center
Jan Lepicovsky, NYMA, NASA Lewis Research Center
Karen Weiland, NASA Lewis Research Center
Richard Antcliff, NASA Langley Research Center

Wim Degroot:

I work in the Space Propulsion Technology Division, more specifically in the on-board propulsion branch, where small rockets are tested. We have electrical and chemical propulsion and the type of rockets we are testing are anywhere from about 5 to 50 pounds thrust, so you have to imagine the size of the combustor, nozzle and the total injector system are of the order of 0.1 to 1.5 inches. We have been using Rayleigh diagnostics for five years, but I have to make a disclaimer – I have not used Rayleigh diagnostics, but Dick Seasholtz has setup initially and Frank Zupanc has used thereafter Rayleigh diagnostics systems to measure velocities and temperatures; most of them in the exit plane of a 33:1 area ratio nozzle which was positioned in a high altitude chamber, a large 3 foot diameter chamber which can be evacuated and maintained to a pressure of about 0.2 psia. The combustor itself has a chamber pressure of roughly 75 psia. It is gaseous hydrogen oxygen combustion. That is not a problem that we are going to talk about today. The nozzle has an area ratio of 33 where the pressure comes out as close to the ambient pressure which is 0.2 psia. And what we are interested in is the velocity distribution of the exit plane, primarily to look at what the CFD people could present us with for comparing CFD predictions with the measurements. One of the problems Frank Zupanc found is that we have a strongly species-dependent flow. The core was very oxygen rich, mostly water, but oxygen rich; whereas the boundary layer was hydrogen rich and the reason is that hydrogen is used as a fuel film to keep the wall protected from oxidation. So when you measure across the exit plane, you will find that when you have oxygen with hydrogen you can model it pretty well because the hydrogen almost doesn't contribute to the broadening of the spectrum. However, if you have 50% water and 50% oxygen the modeling is not so easy to do and you don't know what the species composition is. If you go anywhere from 10% oxygen to 50% oxygen you make use of the oxygen Rayleigh spectrum. You don't quite know what the broadening is of the data and a lot of the uncertainty (and Frank has calculated more or less what the uncertainty is depending on the species concentration) is because of the model functions. What we are very interested in is species distribution, species concentration – what I've seen here is mostly air that has been modeled and that has been measured. But if you have a very strongly graduated species concentration, how do you model them specifically? I guess that's the first point.

The second point I will make much shorter is that we have the same problems that you have. We are in Ohio -- because we run hydrogen we have to leave the doors open in the winter. It is minus 10 to 20 degrees; we have our optics sitting out there; we have a vibrating environment. How do you make sure that you from day-to-day have the same data, same conditions. How do you align. There are problems involving the practical setup of your system. How can you make easier a practical setup without making it such a complicated system like building it up on top of a rig or having to air condition it or having to make all the additional adjustments to your alignment. Ease of application to a research facility should be passed on to the instrumentation developer.

Al Johns:

I'm going to do something a little different. I have worked in a number of facilities so what I would like to touch on some of the issues that we have encountered and what we do encounter at this particular time. What we need is something that can measure ejector profiles for VSTOL aircraft. We need to measure an environment that is highly turbulent, high velocity as well as low velocity--with pressure ratios from 7 down to as low as 1.2; so we have a high range of velocity. One of the things we need is to have quick data turn around time. We need to make measurements in proximity to a ground. In addition to that we have inlets that are mounted all over the aircraft, from the normal ones in the front where we need to see velocity and temperature profiles in the case when you're in ground effects conditions, to inlets that are mounted on top of an airplane where you need to see what flows are being entrained there. Also we need pressures and temperatures and often we need to look at flow angles.

Now there are other facilities that we have on the lab, one of which is the 1 ft x 1 ft wind tunnel, which covers transonic up to supersonic from Mach 1.3 up to Mach 6. Unfortunately, I don't have a vu-graph of this, but in a facility of this nature we're using an extremely small model, which means that it poses a rather unique set of problems. In the model I showed you earlier it's a 10% scale, so in the 9 ft x 15 ft tunnel you have quite a bit of room to use full-size lasers and all your optics. But when you come to a small facility like the 1 ft x 1 ft and the small hardware, we almost require miniaturizing things to really do the job. One of the problems we have, for example, is an inlet that has three passages. We wanted to measure the pressure, though we really wanted to get a velocity contour, and the moment you put a rake in the passages the whole flow-field changes. So you know it's a really critical need to get some non-intrusive measurements, which I think is a great opportunity for the kinds of things that you are working on.

One of the critical measurements that we encounter of course is temperature. We also have an acoustic rig where we run suppressors and things of that nature looking for how nozzles and suppressors perform at pressure ratios that are applicable to the high speed research type aircraft. And we are concerned about temperature-- looking at how the hot lobes and the cold lobes are interacting so we really need to take measurements in those areas non-intrusively. We have inlets and diffusers that are buried behind other parts. So now you need miniaturized instrumentation that you can work in between hardware to get in and look at the diffuser and the way the flow-field behaves in terms of velocity, temperature, and pressure. And of course, we are looking for flow angles of separation. The nozzles are probably the easiest part because they're all the way at the end and you can look at them from the outside in many cases. But there is a need to understand the flow-field that they produce so we can better understand their performance and not penalize the aircraft. So there are a number of things I would say in the area I work in that are in critical

need of help -- pressure, temperature, and velocity flow angles, and so I see it as a good opportunity for work from the area that you are doing.

One of the things in the faster, better, cheaper environment we need to do is to get the maximum data in the shortest amount of time. And we are required to do a quick turn around on the data, not necessarily on-line but surely short turn around. The other thing that Dick Seasholtz also mentioned--in most of these facilities the noise level is extremely high and the air that we deal with is not necessarily clean. So those are the type of obstacles that I see that you have ahead of you and those are the types of problems that we have. I certainly would like to see more of this kind of work being done and in my opportunities in another test I'm going to try and bring Dick in again.

I've also talked with some people at Ames, which has much larger facilities. We were hoping for the next STOVL program to try and get some of this type work done there but STOVL is having its problems these days, so it may be another century before someone else gets back to it--not me. Thank you.

Jai Kadambi:

Thank you. My work is mostly in the area of turbomachinery or multiphase flow in turbomachinery, especially gas turbulence. Things of interest are the efficiency of the machine and efficiency of the stages. The interest is measurements downstream of the stator rows and at the entrance to the stator. Also, an interest exists in making measurements inside the passages of the rotor blades. However, to look at the interaction of the stator wakes with the rotor blades is of interest because that has an impact on the efficiency of the machine. The flow conditions there are temperatures in the range of about 800 to 1500 degree Fahrenheit and pressures which depend on the operating conditions; they could be a few atmospheres or more. Access is difficult. You have maybe one window or a couple of windows; the spacing is small. You may get about an inch diameter or an inch and a half diameter space. An issue is that the flow-field will also have some hot areas--it could be what's coming out from the combustion chamber-- and size could vary. Measurements of interest are temperature, velocity, and density because if you have these then other things for computational purposes can be obtained. Things of interest including turbulence measurements, instantaneous measurements, and measurements of turbulence parameters become quite involved, so there's interest in that area too.

Most of the real life problems involve two phase flows; it's good to note what Dick Seasholtz said-- that you can make Rayleigh scattering measurements in particle laden flows and how much the particle concentration can be. Most of the flows of nature are two-phase flows. Finally, something on condensation. Depending on the rate of expansion, depending on what the expansion parameters are for the flow, you'll have condensation. Some work has been done in looking at condensation. In fact sometime back with Dick's sponsorship we had looked at condensation as a single component flow or multicomponent flow where some would condense out while some of the gases wouldn't. So some of those things could be helpful in a sense of getting an idea of what the condensate size parameters are. I guess one of the questions I would have on uses of these devices is how stable are these devices? And what kind of environment has to be provided, since most of the real life application environments are pretty severe.

Jan Lepicovsky:

I'm involved in turbomachinery measurements. I was looking on the presentations which were given on the last two days from this point of view. First I want to say that the presentations, the whole meeting was very informative and educational. I think the organizers deserve appreciation for that. However; in my view, what I saw was a promising and highly desirable experimental technique in its very, very early stages of development. Especially from the point of rotating turbomachinery, very far from practical applications.

Yesterday the most popular Mach number was a Mach number of 6. I was happy to see today that it dropped down a little bit to lower Mach numbers. I believe that in propulsion the priority has shifted from being the fastest to being the cheapest, I think, as far as the cost of the product is concerned. And definitely in the propulsion system it seems to me that the subsonic range is the range where we will be. Also, as far as the temperature levels are concerned, we are at a rather low temperatures, especially on the compressor side. We are at the range of 400 to 600 K. I remember yesterday that in one paper temperature was measured at the level of 300 K plus or minus 10 K which would be completely unacceptable in compressor measurements because when doing compressor measurements we are using temperature measurements to determine efficiency and this wouldn't be applicable at all so in my unique situation the focus should shift on the applications which are practical in the future.

Especially in turbomachinery it might be very difficult to apply these techniques because we have very restricted optical access to the flow, usually only one sided access and the measurements are in the close proximity of highly reflective solid surfaces. We access the flow through windows; they get contaminated very fast during testing. We have a lot of contamination in the flow. Whoever saw a turbine stage dismounted from a jet engine how dirty and full of soot the turbine stage is. Definitely, we have stuff in the flow that generates a lot of background radiation.

If we want to apply these techniques to practical measurements we need to think not only about the technique development, but also about the technique application. The days when people who developed experimental techniques, people who designed the facility, the people who use it, all live in their own world is gone. We need to look at an inter-related approach. If it happens that we develop a measurement technique and we come to the conclusion that the technique is not applicable at all, then the technique is just an expensive toy. I'm speaking based on my experience in velocimetry which I have over several years. We really need to think ahead when we want to apply new measurement techniques. The test facilities must be designed for the experimental technique. For instance in laser velocimetry if we want to build a small high speed wind tunnel we may use a short nozzle with high velocity gradients, with thin nozzle boundary layers, maybe in the laminar or transitional stage. And the model should be in the low turbulence intensity flow and it could only be close to the nozzle. Another approach: when the nozzle is relatively long with the slow velocity gradient with thick boundary layers, you have to remove the boundary layer so you have additional systems in the tunnel; which might not be desirable from the customer's point of view. However, from the LA system point of view it is desirable because we have to introduce particles somewhere in the plenum and to minimize the particle lag we should accelerate the flow at lower pace. Another example: to measure velocity in the stator of a single stage compressor, we need to have a window over a section of two or three vane channels. In some designs the stator vanes are attached to the shroud, so to facilitate an access, the compressor would have to be redesigned only for the purpose of measurement.

We believe that laser velocimetry is a mature technique started many years ago and is widely available commercially. But I do not know of any instance where LV systems are used routinely by any engine manufacturer for tests which are crucial to commercial engine development. The LV systems very often end up sitting on the shelf. We need to think ahead of time how the technique will be used and how the test facility should be designed. Rich Antcliff talked about a system which was of the size of a Volkswagen car; much larger than test articles. So what I would like to see as an outcome of this meeting is for users to think about the critical requirements on the test facility for this technique. Kurt Annen talked about a probe about one inch in diameter; it would be a feasible size. But the focal length was short. If it was used in a combustor of a diameter of 200 to 400 mm, it would need to be traversed across and it would now longer be a nonintrusive measurement. So we need to think ahead.

Karen Weiland:

This viewpoint will be something completely different. I would like to thank Dan Lesco and Dick for inviting someone from Space Experiments to come to this conference and be part of the users panel. Before we got our new Space Experiments Laboratory two years ago, most of the diagnostics staff, which when I came was Paul Greenberg and myself, was in the same building as the Optical Measurements Branch so there was a lot of interaction there that still continues even though we're now in different buildings. For those of you who never heard about microgravity combustion, I just thought I would give a couple of slides on what it is and why we're studying it. What happens when you take gravity away from a combustion process? This is just a schematic of a simple combustion system. The candle flame on the left is what the flame looks like in normal gravity and on the right is what happens in microgravity. When you have buoyancy on the earth, the air tends to be entrained and the combustion products are removed quickly and the flame has its familiar tear drop shape; it's bright yellow due to the soot that is glowing. In microgravity, the buoyancy is removed so now the combustion products and the oxygen must diffuse in and out of the flame and the flame is typically a lot dimmer and cooler. This is a photograph of some data of a candle flame that was taken almost exactly three years ago on the shuttle. It is a dim blue hemispherical flame. So you can think of Rayleigh scattering on earth, where you would have lots of soot, as not being applicable. But in microgravity it may become applicable because the sooting is greatly reduced in many of our flames.

The trick of course is how to get rid of buoyancy. We have several ways of doing that. One is in our drop towers. This photo shows the size of a typical 2.2 second drop tower rig setup on the bench. It's roughly 0.96 m long, about 0.41 m wide and 0.84 m tall. Everything in your experiment either has to be on this package or you have to figure out how to get it on remotely. Up to date, we've dropped lasers such as small diode lasers and helium neon lasers. We have not transmitted a laser beam through fiber optics but we're investigating that possibility. This is what a package looks like just prior to dropping; it's surrounded by a drag shield. There would be a cover put over this so that the package would actually drop inside of the drag shield and the drag shield at the bottom breaks the air as it falls down the tower. The five second Zero Gravity facility is evacuated so your hardware has to be able to survive a vacuum or you have to seal it. The other way that we have of getting microgravity easily is on our airplanes. This is a photograph of a typical aircraft rig that would fly on our DC-9. Its a little bit bigger (about 2 m long, 0.5 m wide, 1 m high) and in the middle we have an optical pallet that in this case has a rainbow schlieren system mounted on it along with a couple of high speed movie cameras. It's possible that you could build a system to house a laser and then have a separate small rack for your combustion chamber. But it still has to be fairly compact. The power availability on board the aircraft is a lot higher than the drop towers but the g-levels aren't nearly as

low so your science is usually reduced. We like to use the aircraft primarily for testing out engineering concepts for hardware that will fly in space.

The final way of getting the longest and best microgravity environment is in space. This is an artist's conception of the Combustion Modular Facility that will fly in April of 1997. It will have two experiments on board; one will be to study laminar gas jet flames, and the other to study freely propagating premixed flames and this is roughly (you can see by the scale of the person) how big the experiment package is. It's a fairly large combustion chamber that has hardware that slides in and out that's specific for each investigator. And any room in this location is what you get to put your diagnostics in. The rack on the left side has most of the gas bottles and a lot of the electronics so there's not a lot of room on board. This particular facility I'm showing you is basically the precursor of what is going to fly on Space Station. The Fluid and Combustion Facility is now in its conceptual design phase and they are taking a lot of concepts from this module. So the requirements are obvious -- we need a laser source that is compact, low-power but is able to do the job. Our systems that we study run the whole gamut of solid, liquids and gases, paper, foam, metals, droplets, methanol and decane and other liquid fires that have flown recently on a rocket sound flight. Gaseous flames include laminar, turbulent, diffusion of premixed gases, counterflow burners, freely-propagating flames like in a bomb and in a tube. Fuels that we commonly use are methane, propane and hydrogen although we are not limited to those. So we have just about everything covered in the program; it's a very broad program. Actually we have open right now a combustion NRA that is open until Aug. 26. They are released every other year so there's an opportunity right now if you have a good idea.

The measurements that investigators are interested in are temperature measurements in gas phase and liquid phase. We're looking at temperatures from ambient (298 K) to 2000 K with an accuracy desired of 2% and they would take point or 2D. I have the same comment as Wim DeGroot on how to separate out the temperature and composition. We have all kinds of fuels, with hydrocarbon fragments everywhere, water, CO₂, etc. This is a common problem in any refractive index measurement technique such as rainbow schlieren on how to separate out these. This is something that I think could be looked at with a great deal of impact. The velocities are low. We like to call our flames big and slow so the Doppler shifts are small. So I don't see really too much of an application for Rayleigh velocity measurements, although there are some applications where it may work. We're starting to get some investigators looking at turbulence. It's possible we might be able to do something looking at the flowfields and also the mixing of the jet with the outer air layer. We've had one PI who did a laser schlieren looking at the interaction and that boundary was very interesting. I think that will conclude what I want to say so I will turn it over to Rich Antcliff.

Richard Antcliff:

Just for brevity, many of the comments that I would make I made yesterday in my talk and I won't repeat those. I will make a couple of comments; one to follow onto some of the comments that Jan made. One of the things we are definitely being forced to do is to look at cost benefit analysis with regards to these diagnostics. And, frankly, for some of these very large laser systems that becomes a very painful exercise and we had to stop doing some work in development because the potential of actually using some of these systems in a practical environment came close to zero. And our funding now is getting tied to whether you can ever get it into a practical environment so we have to look at those things more closely now than we ever did in the past.

I'll just limit my discussion to some of the concerns if you look at hypersonic facilities. Obviously, the cluster effort is a real concern of ours right now. We're just using the tack of going to high temperatures and eliminating those clusters. But there is a real question as to how you could really utilize those in the diagnostics. One of the problems we have had is that when we get into the clusters regime, our measurement errors go way up because you now have an entity that is unknown in size and composition and you no longer have good control of it. When you get down to the Rayleigh regime we get reasonable errors. So if we are going to use the clusters they have to be quantified somehow. Obviously optical access is a problem as you saw in the work that we did when we tried to provide optical access to a tunnel that was not engineered for it. We obviously distorted the flow and so that's something that is just not acceptable to folks trying to do some quantitative work.

The other problem or concern with regards to these kinds of efforts where we are looking at planar measurements in general really comes down to data presentation. We have found as we try to talk to users is that they get this blank stare across their face when we show them these 2D images as they try to understand what they are seeing as compared to a line plot or something they have used traditionally. So that the whole human engineering part of what does this data mean and what it means to the user and the facility is a difficult animal to overcome. And we've played a lot of games with different ways of displaying the data in order to get that across -- it's not an easy thing. So it's something we need to keep working on and try to do better. The other comment is when we start talking about practical facilities (practical is kind of in the eye of the beholder--the practical facility is the one that I'm working on). It seems like when we go into all these measurements, often it starts off with somebody saying: listen, I have never had any type of measurements in facilities so whatever you can give me is okay. Then you give them whatever we can give them with a reasonable effort and then the next comment is "well this isn't good for anything". So there has got to be a better understanding of what we really can provide with regards to these measurements. Also, there is a wide range as to what people want and what they understand are the benefits of these measurements all the way from the feel-good kind of measurements to "this looks good, thanks I appreciate that, it helps me to understand" down to what the CFD requires, which is very detailed and very low error type of measurements. There's also a wide range of type of measurements to be made that can best be determined by getting together with what the people want and what they really need up front. Because that is the biggest problem: when we get done trying to then say "okay, this is what we have, is that anything close to what you need?" And often it's not.

One of the things that I guess is somehow important to get into the discussion is that there is a lot of effort being done in CFD and a lot of the design work now is being done in CFD and although that is necessarily important, I firmly believe that there is not going to be a new fluid mechanic discovery made through CFD. You are going to have to make them through experiments and the problem right now is that there is not a lot of good experimental research being done in fluid mechanics. Most of it is new codes are being developed to design new aircraft and not in really doing research. In fluid physics that is going to require some of those exotic measurements and they are the only things that are going to give you new insights in the new fluid physics. This really jumped out at us in the NASP program and that's why it hit me so strongly. There were some measurements that we uncovered in the NASP program that were new physics in regimes that no one had seen before and something that CFD could not predict because no one knew that it would be there. Now you can only predict what you know is going to be there. So those kinds of things just concern me and as we look towards the future of these kinds of measurements we can't throw out the baby with the bath water because there is a real need to look at some of those fundamental fluid issues.

Comment by Richard Miles:

I just want to make a comment. It seems to me that we are talking about Rayleigh scattering predominantly at this workshop but it is important to understand that perhaps a hybrid approach in many cases is the right one. I'm struck by the species question. The people in combustion have been looking at simultaneous Raman and Rayleigh measurements, for the Raman is used to identify the species and the Rayleigh is used to measure the temperature. You get a line Raman and a Rayleigh image and that's a way of at least addressing some of these species. When you focus the laser so you have a line, the Raman signal is rather strong—I haven't done the calculation but .2 psi is low so I'm not sure what you'll get— you'll have to go up to UV Raman or some other things like that. I'm not addressing your specific application but just making a general comment. I think that in Karen's case for example, multi-pulse Rayleigh may be capable of measuring low velocities because you can do the same thing that you do with PIV except you're not doing it off of molecular scattering. And in fact when you have a fog in the flow you may not know that the fog follows the flow so that may be a problem. But if there are small enough particles you can do a similar thing. Trinity and his co-workers in France have been doing that and getting very good essentially PIV images using sort of a continuous fog or smoke in some of their jets. So I just wanted to point out that I think it's important to try to combine some of these things and try to use the strong points of each. The other point I would make is that a lot of these experiments are being done with lasers and other systems that have not yet been hardened. I think you have to recognize that if we really want to build some devices that are going to be capable of taking reliable measurements we have to get some industries in the loop that would help us harden these things and that's going to cost some money. Otherwise we're going to be using very expensive, very versatile, but potentially not the proper lasers in order to try to do something, and I think that is going to lead to a lot of error.

Panel discussion 2

Direction of future work in Rayleigh scattering diagnostics

Panel Members

Mo Samimy, Ohio State University
Richard Miles, Princeton University
William Pitts, National Institute of Standards and Technology
Charles Tyler, Wright-Patterson Air Force Base
Kurt Annen, Aerodyne Research Corp.
Volkan Otugen, Polytechnic University

Mo Samimy:

It was very interesting to hear from the users group. I have been in a couple of other similar discussions recently. Unfortunately, there seems to be always a wide gap between the users and those who develop and use diagnostic techniques. A similar type of gap also exists between CFD researchers and the users. Until a few years ago, I really did not think that there was any concerted effort to bring these groups together. However, within the past few years I have noticed some effort in that direction. For example, the Air Force Office of Scientific Research (AFOSR) has been supporting turbulence modeling for years. I do not believe that up to recently, there was much emphasis on whether these models were used in any applications. But, AFOSR has recently been bringing the CFD people and the users together in an effort to put these models to use. In a recent meeting, a turbulence modeler was discussing his effort on a very advanced turbulence model; a structure based turbulence model. Right after this talk, a user from an aircraft company said that they were still using Euler's equations, not even Navier-Stokes equations, to calculate pressure and thus the lift on an aircraft. This is the gap I am talking about. I hope meetings such as this organized by NASA to bring various groups together will take place more often.

Some other issues came up in the discussion. For example, how important is the basic science to application? I think it is very important. I believe, one can use a very simple geometry in an effort to understand what is happening in a complex real-life geometry. But, eventually we have to address the problems associated with complex geometries. Researchers must work together in order to use a techniques developed in a laboratory in an application oriented facility. Unless both groups make an effort, this will never happen. We must try to understand the needs of users and try to direct our efforts to resolve problem they are facing with. User must also try to understand the limitations and problems that we are facing with. To succeed, we must work together.

In regard to diagnostics development, I would like to say a few words. To understand a complex flow, we must have 3-D velocity measurements. I would like to see more people get involved with techniques such as filtered Rayleigh scattering and Doppler planar velocimetry. These techniques require more development, if they are to be used routinely in laboratories. Unfortunately, only a few people currently working on the development and application of these techniques. Simultaneous measurements of velocity

and thermodynamic properties are extremely important. We need to understand correlation among these to understand complex flow fields. We have been working on a technique for this purpose, and have obtained decent results. But more development is needed.

We have to improve temporal resolution of some of the technique we discussed earlier in order to get real-time measurements. Presently, both lasers and cameras are designed for much slower repetition rate. For the past six months, we have been looking into this problem. We currently are able to use a double pulse laser with two cameras to investigate evolution of structures in a flow. But we need to get many pulses, a burst of pulses, to follow the structures and understand their evolution. I have talked to Dick Miles and others about current status and development of very high repetition rate lasers and CCD cameras. As most of you know, all the scientific grade CCD cameras are slow scan cameras and cannot provide very high frame rates. Recently, some clever designers are using a single large CCD, then deflecting electron from one frame to another to place them in the different areas of the CCD. With these CCD's you can get very high frame rate, but very limited number of images. So we need significant development in both CCD camera and laser technology in order to go beyond where we are now.

Question from audience:

What is the velocity range that you can cover now?

Answer by Mo Samimy:

In some of the techniques discussed, as the velocity goes up the accuracy of the technique improves. There is no real limit. With the filter planar velocimetry technique, you can measure both positive and negative velocities. The filter we are using is a pressure broadened filter. There is a linear region in the filter. You locate your laser frequency at the middle of this linear region. Doppler shift from particles/molecules with positive velocity will move to, say, right and with negative velocities will move to left. Then the measured intensity is directly proportional to velocity. We can look at a full recirculating flow with a wide velocity range. You can modify the slope of the filter to optimize the technique for the velocity range of interest. The slope covers a Doppler shift of about two GHz.

Richard Miles:

In the work that we have been doing we're trying to find out what the real precision limit is, and it's about 10 meters per second right now given the laser constraints. And so that means if your going to slow flows like 10 meters per second you'll have about 100% uncertainty. Our expectation is that that can be improved, and then using double pulse techniques probably improved upon even further. But that's sort of the order of magnitude for this kind of approach.

The first thing I wanted to point out is that I think we're coming from a mind set which I think we ought not to have. I note that if we think about these facilities as large scale analog computers, building a computer with no data output is not something you would contemplate in the computer business. I think that we need to talk about integrated systems. As you may know the United States is mounting about a 1.5 billion dollar effort to build new facilities to look at high Reynolds number flow. There's been no

effort to include any diagnostics in those. I think that is just unconscionable. I think we ought to be talking about integrated facilities and really making an effort to put our support behind advanced diagnostics where they're needed. If they're not needed, then that's another question. But to say that the diagnostics is going to be cheaper than the facility or visa versa I think it is to presuppose a lot of things. The possibilities now that are coming on board are very exciting. And with some infusion of support, if someone is seriously interested in getting this data, I think that there can be things done.

Now to return to some of the issues that were raised here. I'm personally excited about the filter technologies and I think perhaps marrying them together with other hybrid systems is something that we all have to look forward to. I would just point out that we have not yet even started to scratch the surface on the filter technologies. There has been a lot of effort on atomic filter technologies that has been in the lidar community and also in some of the defense communities looking at communications with submarines. But we have a different application here. We're obviously interested in coming up to the ultraviolet, and there been some discussion about that. There is some discussion about whether you would rather want to use blocking or transmitting filters. A notch transmission filter is a very interesting capability. The possibility of imaging rotational Raman scattering, so that you eliminate all the background scattering from particles is an attractive one. I have a slide on that but I won't show because we're running a bit behind.

Also of course if you want to try to tailor your filters, you may be able to set up a filter laser arrangement which just measures, say, pressure. We have done some initial modeling in that and that looks very attractive. You may be able to harden the system like that which will go into a facility and give you a pressure measurement. You may be able to put together another system which will give you just a temperature measurement. The lidar community has been examining temperature measurements systems and has had quite a bit of success in that area. I think that you can talk about filter pairs, so you take multiple measurements in the same shot. You can be clever about that. You can stack them up potentially so that you don't lose a lot of light. What one filter takes out the next filter sees and things like that. So I would challenge people to think about that and to really address those issues. here is a lot of room in this type of field for new ideas that couple together with specific sources or potentially even sources which have yet to be developed. I think that potassium filters have been discussed. We are now looking at HI filters to get into coupling with diode lasers and do some measuring of particulate scattering and pollution in the atmosphere and such things as that. The laser technologies again are very interesting.

Obviously trying to come up with locked lasers might be an appropriate thing to do. I noticed that Dick Seasholtz was using a locked helium-neon laser. There didn't seem to be a great deal of brouhaha about the fact that he was using that. That's locked to iodine unless it's a Lamb dip laser. So the iodine locking technology for the helium-neon laser is 20 years old, if not older. The possibility of locking some of these YAG lasers to iodine is not a big deal. And that would be, I think, a tremendous benefit for stabilizing some of these things that seem to be drifting all over the place. As Mo Samimy said, fast cameras are under development and I think that looks very attractive.

The question about whether to look at particles or air or fog is an interesting one. Obviously there are some trade offs associated with it. Not the least is what is the name you call a particular diagnostic. There is velocity sensitivity. In some cases the particulate fogs will be very interesting in low speed fluid flows. Also there is a question as to how do you get rid of scattering from the fog if you don't really want it. Multiple pulse imaging I think is also an exciting area. So I think there are a lot of exciting areas out

there. I think that some of these systems are coming up to the point where we can begin to try to harden them up and use them in large scale facilities. Try to make them robust against acoustic noise. We have an acoustic noise level of 120 decibels in our facility, and that's a challenge to make sure things work. So I think what we need to do is try and bring some of these on board. I hear the comment that we really need to get out there and apply these things in the field and I think that is true. It doesn't make any sense to be still using small scale facilities except as a first step. Thanks

William Pitts:

First with regard to the users panel. The discussions I heard today were identical to the discussions I have heard in every other field where I'm looking at diagnostics. That includes combustion as well as concentration measurements for halon replacements. We hear the same thing over and over again. We need this, or here's what we can give you, and they are about this far apart. At some point these things have got to come together. A lot of money has been spent on diagnostics, not just in this area, but in other areas as well. We still have a long way to go. I think an example of that is what we did personally at NIST as far as Rayleigh light scattering is concerned. We wanted to use it to make concentration measurements. We ultimately designed our experiment around the diagnostic, which is maybe not the best thing to do when your talking about real world applications. But I think we are probably getting about as far as we can go right now with what we have available in our laboratory as far as understanding turbulent mixing. And I'm not sure that's a bad thing, but it's just understanding mixing; its not going to help us design a better combustor unless somebody else takes the next step. You always have to keep that in mind; that there's always has to be somebody to take the next steps. The best way to do it is to have meetings like this where everybody just sits down and keeps talking to each other. As long as people keep talking, maybe things will work out.

As far as details about the future work in this particular area of Rayleigh scattering and line filters, I'm probably not the best person to address this point. But there were several things that struck me. First of all, image detectors are an area that can easily be improved. I find this idea of particles to be pretty extraordinary. They're there and no one has a clue as to what they are. There must be a way to get around that problem without too much difficulty, I would think, if someone sits down and spends some time, and a little bit of money perhaps. Right now it seems that concentration is not being emphasized, and yet in certain cases Rayleigh scattering really is quite good for concentration measurements. I would suggest that concentration measurement be included in the overall program. I got the impression that a great deal of the images which are being taken are time averaged, and I really think that is not the appropriate way to use these techniques. You should be trying to do as much temporal resolution as possible, and you should be moving toward real-time measurements. And those are two different things in my mind. A temporal resolution of nanoseconds is great, so you are ok there. But real time means you have to be able to watch it during the time that changes are occurring. For the type of flows you folks are looking at -- those are very very short times. You got a long way to go before you can push that far.

Question by Richard Antcliff:

I often hear the comment with regards to making temporal measurements or especially as related to turbulence and one of the fellows in the earlier panel talked about making turbulence measurements, and I guess I still have a question as to what the real need is with regard to measurements? What is the real

requirement for measurements with the regard for temporal resolution? Do we need four dimensions, three dimensions of the image and time in order to get turbulence information? Do we need line images? Single point images? What's really going to get us information that people in the turbulence community are looking for from diagnosticians?

Answer by William Pitts:

It's almost philosophy at this point. If you sit down and say I'm going to make a $1000 \times 1000 \times 1000$ measurement and I'm going to do it in real time, just multiply the numbers and you will find out that you are not going to do that. There is no computer in the world that's going to store the data. Clearly that's not the way to go. People who are doing direct numeric simulations get into the same problem. They have to store their data on the fly, isolate what they want to look at, and then try and come back later and see what happens. So that is clearly not the way to go at this point in time, at least with current technology. But there are possibilities of learning new things, and ultimately one would hope those new things are what will go into new turbulence system. I find the idea that large scale structures, which are present in every turbulence model you ever look at, are highly organized and yet they are not in any of the models right now. So clearly, the more we can learn about that particular aspect, the more likely it is that may ultimately go into the models and almost certainly improve their predicative capability for the future, particularly with regard to reacting flows. There is no set answer to your question. It has to be a step and feel process as you go forward. But I know there are things happening in those flows that can be detected by diagnostics, particularly real time diagnostics, that can ultimately go into models. Its just the matter of people doing the proper thinking, reaching the point at which they can do that. And that's the way almost all science goes. Very seldom is it a lightning stroke that says "oh yeah, this is exactly what we have to do". It's almost a random walk that moves forward. Turbulence is going to be the latter. Enough smart people have thought about it over the years that it's not going to be that sudden flash.

Comment by Richard Miles:

Let me make one comment because I think it's important to recognize that many of the measurements that have been made have been made using hot wires, which are time measuring devices. But in order to study the turbulence that signal is then converted using Taylor's hypothesis to a spatial quantity. So I think rather than trying to do all things for all people, we have to recognize that in some cases the spatial measurements have much of the same information. In fact in some cases they are more useful because we don't have to make the Taylor hypothesis. So it then turns into a question of scale and correlations between such things as velocity and density. What you really would like to do is to be able to measure the properties, maybe two components of velocity on a small scale and learn the scalar dissipation rates, and eddy turnover times, and dissipation phenomena. That tends to be at scales which are on the Taylor microscale or smaller. And that is very important in order to be able to add into the turbulence modeling, typically that's millimeters or smaller depending on the Reynolds number of the facility.

Question by Jay Panda:

Is there any way you can measure velocity instantaneously using a CW laser?

Answer by Mo Samimy:

You can do a single point measurement. The ultimate goal is to measure 3-D velocity, together with other parameters, in a volume. But, one step at a time. If you use a CW laser with filtered Rayleigh scattering technique, you can do a single point velocity measurement using particles in the flow. If you want to do it in on a line, you need a 25 W narrow bandwidth CW laser. The advantage of this system is that you can get real-time measurement if you use a very fast line array.

Comment by Richard Miles:

But the first thing you will do is use the Taylor hypothesis to change that to a spatial measurement. That's what the theoreticians are going to do with that data. The hardware measurements that you make will have to be converted to spatial measurements to be used in the model.

Charles Tyler:

As far as I can see from my viewpoint down at Wright Lab, we have to address the theory first, and that is what we have been doing here, before we can apply it to real things. I didn't even know that test articles could even be as small as 200 millimeters wide, or as Wim DeGroot said, one foot for an entire rocket combustor. But as far as our laser system being miniaturized, I think that is happening. Look at it this way, it took 20 years for a computer to go from the size of a room to fitting on your wrist watch. I was talking to Rich Antcliff last night about the excimer lasers. They went from the size of a small Volkswagen to about the size of this podium behind me in a few years. I know that's not tiny, but its in the right direction of miniaturization. I'm not anywhere near high enough on the learning curve to say anything about the systems being developed. I don't know what wavelengths or spectroscopy is out there to use, but it seems like whenever we go into a tunnel, reality strikes us in the face and theory doesn't match. We run into particles and in supersonic flows (Mach 3, 6, 12) condensation particles and dust that just doesn't match the theory and we're trying to work that out. We go into our subsonic flow facilities, which are open loop, and you get crosswise wind gusts, which throw off the measurements. I don't know how to approach the correction for that, but we are trying. And we are getting closer all the time.

Comment by Jan Lepicovsky:

I don't think that people would mind if the instrumentation is large and sitting in the next room. What must be small is the front end. So there is no need to miniaturize the whole system, but at least the front end has to be small because otherwise there is no access.

Comment by Charles Tyler:

There are companies who are working on measurements systems that you actually stick onto the article itself. We had a SBIR that used optically smart surfaces. It had a laser velocimeter built into a strip of a hologram. You just strike that hologram with a laser beam and it created the probe volume in the field that you wanted. (Metrolaser) They just tried it out in the 2 foot tunnel that we have which goes Mach two. I don't know if that would work in a stator rotor situation or not, but it could always be tried.

Kurt Annen:

My interests are primarily in developing Rayleigh scattering diagnostics commercial applications. So a couple of characteristics are that they need to be simple and not too expensive. Our efforts have been in developing Rayleigh scattering probes to measure density or temperature based on intensity and then using the dual line technique to compensate for the background which will always be there. I think that for a modestly-priced commercial or simple-type device, employing a spectrally resolved Rayleigh scattering measurement technique probably is not feasible, which is unfortunate because that is where the greatest power is as well. With spectrally resolved Rayleigh scattering, you can measure velocities and take care of the background scattering. But I think that for moderately-priced systems where there is the hope of developing something that can be sold in quantity and have an inexperienced user or at least somebody who doesn't have a PhD or masters degree in optics to be able to use, the idea of using spectrally resolved Rayleigh scattering is probably not going to work. Maybe what that means is for a lot of applications, Rayleigh scattering really cannot be used. For those applications where you are trying to make measurements in enclosed environments where you can't really deal with the background scattering and either you don't have the resources or don't have the experience to use the spectrally resolved technique, maybe you just can't do the measurements.

For applications where you can use a compact probe to do intensity-based measurements, there is another issue of how to get the laser power to and from the probe. Or maybe you don't necessarily need a probe, but instead can put in a couple of small windows. Our experience is that even in working with optical fibers there are often problems in transmitting the desired intensity through the fiber, and the beam quality that you get out is not as good as what you would have if you were able to inject the laser beam directly. It doesn't mean that fibers are out. It just means that your problem is more difficult if you have to use fibers to supply the laser power. One positive side of doing Rayleigh scattering measurements with a probe is that often you will do it in closed environments which are used at higher pressures, and that is where the density dependence of the Rayleigh scattering helps tremendously. The background will not go up with pressure whereas the Rayleigh scattering signal will, so that moves things further into the realm of feasibility. It's possible that in going towards the UV, things will become even easier. Volkan Otugen's results yesterday which showed very little scattering at 266nm were very interesting. I don't know if that will always be the case, though. Certainly you have an advantage in terms of the Rayleigh scattering cross section being much higher. But then again, if you are going to use fibers to transmit the laser intensity from the laser to the probe or to your measurement location, operating in the UV become more difficult. You may have unacceptable intensity losses if you have to transmit over large distances.

In many measurement applications, another larger issue is that of particles. Often with a compact probe you are not able to form as small of a measurement volume as you could if you were able to use large, low f-number optics. That means then particle concentrations on the order of 10^4 per cc, which is relatively a low particle concentration in general, might be a limit above which one needs to look carefully to see whether intensity based Rayleigh scattering measurements can really work. For combustion systems though, if you don't have a large amount of soot formation, a lot of the ambient particles that you faced with in the wind tunnels just aren't present, and so maybe the particle problems are reduced.

And finally, I just wanted to make one comment regarding the problem with unknown mixture ratios in these measurements. One common technique that has been used in the past is that where you have a well mixed high temperature combustion flow field mixing with air, or even in gas turbine combustor where you have a pretty well mixed primary zone mixing with secondary air such that you have a pattern factor at the exit of your combustor, the temperature will correlate quite well with the mixing ratio. You can essentially compensate for an unknown mixture by correlating the temperature with mixing ratio to come up with a fairly low uncertainty determination of the mixing ratio to use in your Rayleigh scattering measurements. For reacting flow applications, like a hydrogen-oxygen thruster, where you have two reactants or let's just say the fuel and the oxidizer, that type of approach won't necessarily work. But if you have other well-mixed, hot combustion flow with the reactions fully completed, mixing with air, then that approach would work pretty well.

Volkan Otugen:

Just to have Dick Miles on record, he took exception to Kurt Annen's opinion that spectrally resolved Rayleigh scattering can't, in the future, be used as a routine technique. I think it's a matter of how robust you make the system, and I think that will have to do with how much interest there is going to be. Take LDV -- a lot of people can use LDV. When it first came about, it looked pretty sophisticated I think. Let me just say a few things in general. What I want to do is try to summarize what I understood of what the previous panel application people were talking about. I put things in three categories, which don't necessarily 100% overlap in terms of needs and requirements. One category is the model testing in large facilities. These have their own types of restrictions like size of probes, access, dirt and clutter, and so forth. That's one type of problem, and of course the range of parameters that you may encounter when you are trying to measure different properties at the same time. The other category is the fundamental flow physics, where you are trying to understand, typically, the fundamentals of turbulence in a new type of configuration. That has different requirements. First of all you can set up your own little facility and do the experiments the way you like. Therefore you can build a facility around the diagnostics system, and if you obtain initially qualitative results that could be ok in understanding the fundamental physics of the problem. The third category is the CFD validation, where you need a large quantity of highly accurate data to compare with the CFD models, and that has its own different set of requirements. So I think some of the needs are common in these three different categories, but they do have their specific needs also that are separate from one another.

Now in particular, I think Rayleigh scattering going toward UV is obviously a good idea, and I think it's becoming very clear. Except Kurt Annen has a point that it is a little more difficult to use fiber optics when your dealing with real short wavelengths. That's something to consider if this is going to be again a more or less routine technique. The other thing is the measurement of low velocities. Dick Miles says

10 meters per second is the smallest velocity that can be resolved. Of course, I think there are people here in the microgravity areas or in other area who are interested only in the velocity range under 10 meters per second. In that case I think maybe hybrid techniques may have a point where you might have Rayleigh and particle scattering. And particles can be actually a lot larger than the Rayleigh scattering range because your velocity and accelerations are not going to be as high as you would have in a supersonic or hypersonic flow situation, especially if you're just looking at velocity and don't care much about temperature. I think the use of larger particles would improve your accuracy.

The other thing is that I think ultimately we would have to use different types of filtering techniques for very low velocities. One thing that came to my mind when the other panel was up here is that a couple of months ago Dick Seasholtz sent me a paper, I think from a astronomy journal or a atmospheric measurement type journal, where actually I think they were using etalons for filters. It's basically a Fabry-Perot interferometer with a pinhole in the center of the image of fringe pattern . It is set up so, with no Doppler shift, 25 or 35 percent of the total light that you collected will be transmitted through the pinhole. Now if the frequency is shifted, the rings will either move in or move out, and you would be just left in the dark. So by inverting that, it can be used as a very sharp, tunable filter by changing the distance between the etalon mirrors. I don't know in practice how it would work in our field, but this is something I think we should look at. I would like comments from other people on this.

One last comment is in regard to hot wire measurements, where Taylor's hypothesis must be used to convert time series data into spatial data, which is absolutely true. But I'm going to pose another question: how about if you have a seriously unsteady problem where you can look at a full field or a two dimensional image, but you still to have to have time series information even if it's two dimensional. So that's still a challenge that has to be overcome. One of the problems is the low rep rate of the lasers. And of course if you want to do imaging, another problem is the speed of how fast you can move the information from each pixel, which is something like 50,000 pixels per second. If you have a really seriously unsteady flow, then maybe you must give up the idea of planar measurements and do local measurements, but try to acquire the information at a high rep rate. But if you use a pulse laser, I don't think it's possible to obtain time series information.

Comment by Richard Seasholtz:

The technique that you were referring to is being developed at Goddard. I think they refer to it as the edge technique. (C.L. Korb, B.M. Gentry, and C.Y. Weng, "Edge technique: theory and application to the lidar measurement of atmospheric wind", Appl. Opt. 31, pp. 4202-4213, 1992.)

Comment by Richard Miles:

I think the comment that I was making actually was not intended to say that it's 10 meters per second, but it's probably 2 meter per second. And there is sort of a fundamental difference whether you are looking at air or particles. The line broadening of air is about a gigahertz, and a meter per second is about a megahertz. If you are talking about a part in a thousand measurement of peak position, that's were you get into trouble because the peak at that level is pretty flat. You can begin to push one way or the other

by integrated for along time. But if you use a double pulse or multiple pulses, correlations can be used pick up slower velocity measurements.

Comment by Jan Lepicovsky:

The users' needs to make measurements in a variety of conditions and the need for time resolved measurements mean additional money and time has to be spent. But on the other hand we complain that the new tunnel which is built by Boeing doesn't have optical access. I think it is partially our fault that we are not vocal enough about this technique, and secondly maybe they are going to very different direction world wide. Let's look at from the point of the hot wire. Hot wire probes are not suitable for all flow applications. Laser velocimeters are also not suitable for all flow applications. Maybe Rayleigh scattering is also not suitable for all flow measurements. Maybe in my field of turbomachinery measurements it is so complicated that it will not help. I would say what we should do is that we should concentrate on what is available now; look in which fields and which applications we really can show that this technique is either better or bring some new results which are useful. If the manufacturer of Rolls Royce cars would promote there cars only on the fact that they can carry you from point A to point B, people would still be buying Volkswagens. So what I would like to see it shown that these new techniques are viable and will give us something better.

ATTENDEES

Kurt Annen	Aerodyne Research Corp.
Richard R. Antcliff	NASA Langley Research Center
Pamela Barry	Ohio State University
Alvin E. Buggele	NASA Lewis Research Center
David O. Davis	NASA Lewis Research Center
Robert E. Edwards	Case Western Reserve University
Gregory Elliott	Ohio State University
Joseph N. Forkey	Princeton University
Louis J. Goldman	NASA Lewis Research Center
Mark S. Habermusch	NASA Lewis Research Center
Albert L. Johns	NASA Lewis Research Center
Rich Jones	NASA Lewis Research Center
Jaikrishnan R. Kadambi	Case Western Reserve University
Jan Lepicovsky	NYMA, NASA Lewis Research Center
Daniel J. Lesco	NASA Lewis Research Center
James Lock	Cleveland State University
Richard B. Miles	Princeton University
M. Volkan Otugen	Polytechnic University
Jayanta Panda	NASA Lewis Research Center (RRA)
Svetozar Popovic	Weber Research Institute, Polytechnic University
William M. Pitts	National Institute of Standards and Technology
Mark F. Reeder	NASA Lewis Research Center (National Research Council Associate)
Mo Samimy	Ohio State University
Richard Seasholtz	NASA Lewis Research Center
Charles Tyler	Wright-Patterson Air Force Base
Karen J. Weiland	NASA Lewis Research Center
Mark P. Wernet	NASA Lewis Research Center
Khairul Zaman	NASA Lewis Research Center

REPORT DOCUMENTATION PAGE

Form Approved
OMB No. 0704-0188

Public reporting burden for this collection of information is estimated to average 1 hour per response, including the time for reviewing instructions, searching existing data sources, gathering and maintaining the data needed, and completing and reviewing the collection of information. Send comments regarding this burden estimate or any other aspect of this collection of information, including suggestions for reducing this burden, to Washington Headquarters Services, Directorate for Information Operations and Reports, 1215 Jefferson Davis Highway, Suite 1204, Arlington, VA 22202-4302, and to the Office of Management and Budget, Paperwork Reduction Project (0704-0188), Washington, DC 20503.

1. AGENCY USE ONLY (Leave blank)		2. REPORT DATE August 1996	3. REPORT TYPE AND DATES COVERED Conference Publication	
4. TITLE AND SUBTITLE Rayleigh Scattering Diagnostics Workshop			5. FUNDING NUMBERS WU-505-62-50	
6. AUTHOR(S) Richard Seasholtz, compiler				
7. PERFORMING ORGANIZATION NAME(S) AND ADDRESS(ES) National Aeronautics and Space Administration Lewis Research Center Cleveland, Ohio 44135-3191			8. PERFORMING ORGANIZATION REPORT NUMBER E-10200	
9. SPONSORING/MONITORING AGENCY NAME(S) AND ADDRESS(ES) National Aeronautics and Space Administration Washington, D.C. 20546-0001			10. SPONSORING/MONITORING AGENCY REPORT NUMBER NASA CP-10186	
11. SUPPLEMENTARY NOTES Responsible person, Richard Seasholtz, organization code 2520, (216) 433-3754.				
12a. DISTRIBUTION/AVAILABILITY STATEMENT Unclassified - Unlimited Subject Category 35 This publication is available from the NASA Center for AeroSpace Information, (301) 621-0390.			12b. DISTRIBUTION CODE	
13. ABSTRACT (Maximum 200 words) The Rayleigh Scattering Diagnostics Workshop was held July 25-26, 1995 at the NASA Lewis Research Center in Cleveland, Ohio. The purpose of the workshop was to foster timely exchange of information and expertise acquired by researchers and users of laser based Rayleigh scattering diagnostics for aerospace flow facilities and other applications. The workshop was attended by about 30 individuals from government, industry, and universities. This Conference Publication includes the 12 technical presentations and transcriptions of the two panel discussions. The first panel was made up of "users" of optical diagnostics, mainly in aerospace test facilities, and its purpose was to assess areas of potential applications of Rayleigh scattering diagnostics. The second panel was made up of active researchers in Rayleigh scattering diagnostics, and its purpose was to discuss the direction of future work.				
14. SUBJECT TERMS Rayleigh scattering			15. NUMBER OF PAGES 222	
			16. PRICE CODE A10	
17. SECURITY CLASSIFICATION OF REPORT Unclassified	18. SECURITY CLASSIFICATION OF THIS PAGE Unclassified	19. SECURITY CLASSIFICATION OF ABSTRACT Unclassified	20. LIMITATION OF ABSTRACT	