

5/4-37
6-2-81

DESIGN AND IMPLEMENTATION OF A DIGITAL CONTROLLER FOR A VIBRATION ISOLATION AND VERNIER POINTING SYSTEM

Daniel J. Neff and Colin P. Britcher
Department of Aerospace Engineering
Old Dominion University
Norfolk, VA

SUMMARY

This paper discusses the recommissioning of the Annular Suspension and Pointing System (ASPS), originally developed in the mid 1970's for pointing and vibration isolation of space experiments. The hardware was developed for NASA Langley Research Center by Sperry Flight Systems (now Honeywell Satellite Systems), was delivered to NASA in 1983. Recently, the hardware was loaned to Old Dominion University (ODU). The ASPS includes coarse gimbal assemblies and a Vernier Pointing Assembly (VPA) that utilize magnetic suspension to provide noncontacting vibration isolation and vernier pointing of the payload. The VPA is the main focus of this research. At ODU, the system has been modified such that it can now be operated in a 1-g environment without a gravity offload. Suspension of the annular iron rotor in five degrees-of-freedom has been achieved with the use of modern switching power amplifiers and a digital controller implemented on a 486-class PC.

INTRODUCTION

The Annular Suspension and Pointing System (ASPS) is a precision payload pointing system designed for use on the space shuttle. In the early 1970's, NASA's Earth-Orbital Systems Technology group established a need to develop a multi-purpose experiment mounting platform to meet the needs of solar, stellar, and earth viewing experiments planned for the 1980's [1]. The prototype hardware (ASPS) was developed for NASA Langley Research Center by Sperry Flight Systems (now Honeywell Satellite Systems). ASPS was delivered to NASA Langley Research Center in 1983, but was never recommissioned due to shifts in program priorities. In late 1992 the hardware was loaned to ODU so that it would be recommissioned and further developed.

GENERAL DESCRIPTION

The ASPS consisted of several systems, a payload mounting plate, the Vernier Pointing Assembly (VPA), two coarse gimbal assemblies, a mounting and jettison assembly, as shown in Figure 1, as well as a control electronics rack, various testing fixtures and assorted connection

hardware. The VPA contains an annular iron rotor with an L-shaped cross-section that supports the payload mounting plate. Five magnetic actuators, referred to as Magnetic Bearing Assemblies (MBAs) provide attractive magnetic forces to suspend the annular iron rotor in five degrees-of-freedom. The magnetic bearing assemblies control the payload tilt of ± 0.75 degrees (initial configuration). The VPA also contains a roll axis drive which can provide unlimited rotational motion about the axis perpendicular to the payload plate. Two coarse gimbal assemblies were stacked to form an elevation and a lateral gimbal pair, providing a mechanically limited travel of ± 100 degrees (from vertical) about the lower elevation gimbal axis, and ± 60 degrees about the upper lateral gimbal axis. The magnetic actuators were initially sized to accept payloads weighing up to 600 kg (later increased) with a center of mass positioned up to one and one half meters above the payload mounting plate [2].

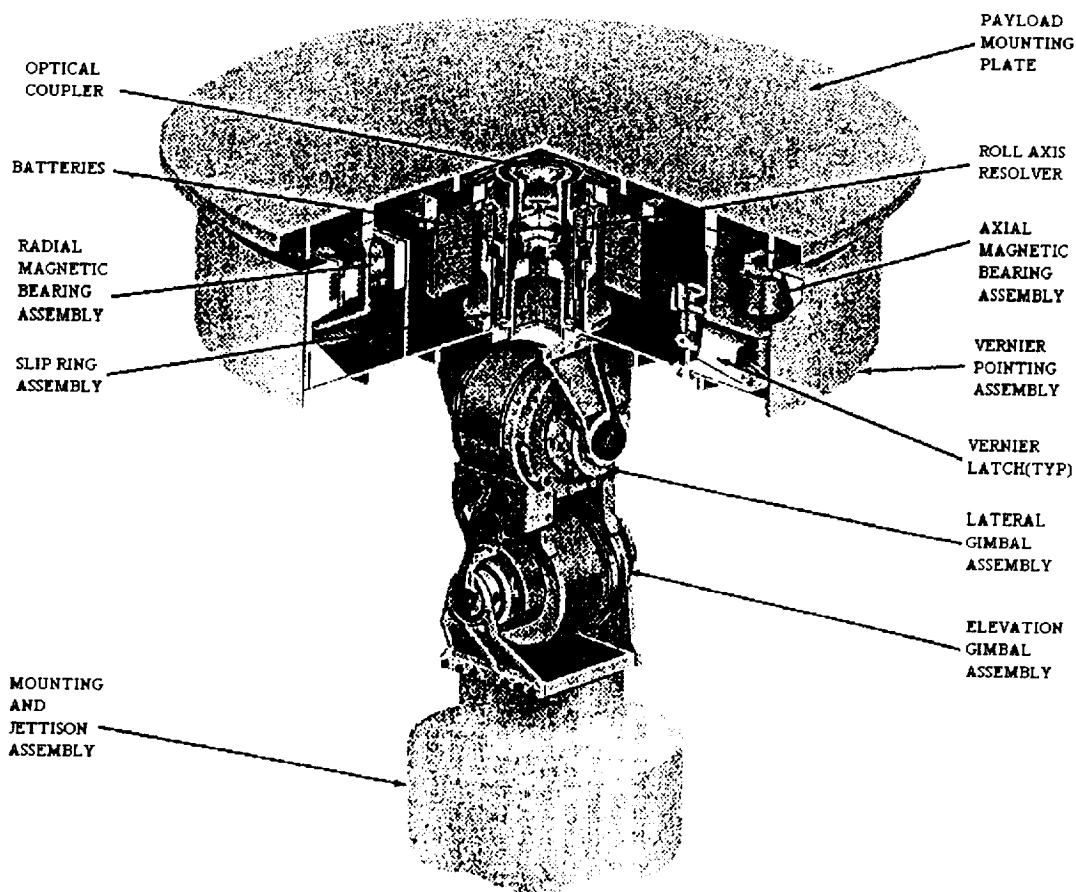

Figure 1 Annular Suspension and Pointing System

The mounting and jettison assembly supported the coarse gimbals and also contained pyrotechnics to jettison the ASPS (and payload) in the event of multiple failures which prevented stowage in orbit. The control electronics rack is an assembly of analog circuits made up of power amplifiers and data acquisition to control the vernier pointing assembly. The balance and testing fixture is a gravity off-load used to simulate a zero-gravity environment.

Hardware Status and Project Goals

Of the systems described above, only the VPA, control electronics rack, and balance and testing fixture were loaned to ODU. The goal of this project was to develop a modern digital control system to suspend the annular iron rotor against gravity in five degrees-of-freedom, and to develop the necessary hardware and software. Once the system became operational, future work could concentrate on improved control algorithms and hardware upgrades, with the objective of steadily improving performance [3].

COMPONENT DESCRIPTIONS

Vernier Pointing Assembly

The VPA provides the ASPS with its high resolution pointing capability. The VPA was originally composed of an annular iron rotor, three axial magnetic bearing assemblies, two radial magnetic bearing assemblies, a roll motor, a total of twelve proximity sensors, five vernier latches, a roll resolver and rotary transformer, and standby battery packs, as shown in Figure 2. However, the rotary transformer and standby batteries were not fully developed [2]. The three axial MBAs, two radial MBAs and roll motor actively control the six degrees-of-freedom of the annular iron rotor, whose mass is 21.59 kg. The axial MBAs control the translation and angular rotation of the payload about two axes and the radial MBAs control the lateral position, providing radial centering. The roll motor controls the sixth degree-of-freedom about the axis perpendicular to the payload plate. The axial MBAs react against the horizontal surface and the radial MBAs react against the vertical surface of the annular iron rotor. The displacements of the rotor are sensed by proximity sensors. Each axial and radial MBA incorporates a pair of proximity sensors. The roll motor has two pairs of proximity sensors to assist in compensating for stray forces and torques produced by the roll motor.

Magnetic Bearing Assembly

The electrical and mechanical descriptions of the axial MBAs is contained in Figure 3. The force capacity of the axial and radial magnetic bearing assemblies are $\pm 28.9\text{N}$ and $\pm 14.2\text{N}$ respectively. The operating range of the axial and radial assemblies were $\pm 5.6\text{mm}$ and

$\pm 5.1\text{mm}$ respectively*. The magnetic actuators consist of a wire-wound magnetic coil and a core material manufactured out of 50% Nickel-Iron. The magnetic coils for the axial and radial MBAs are wound with 810 ± 1 turns of #20 AWG, HML insulated copper wire and 863 ± 1 turns of #22 AWG, HML insulated copper wire, respectively, with two coils connected in series.

Proximity sensors

The proximity sensors used on the ASPS were developed by Kaman Instrumentation, and are still commercially available. These noncontacting sensors use the principle of variable impedance caused by eddy currents that are induced in the conductive target by the sensor coil. The coil in the sensor is driven by a 10 MHz crystal-controlled oscillator. Excitation of the sensor coil generates an electromagnetic field that couples with the target. The gap between the sensor and target affects the strength of the electromagnetic coupling. The changing gap causes the impedance of the coil to vary, which unbalances the bridge network in the electronic package. The MBAs use two sensors one on each side of the iron rotor. The signals from each sensor are demodulated and differenced in an electronic package mounted on the VPA under one of the radial MBAs.

Roll Motor

The roll motor used on the ASPS is an AC Linear Induction Motor [2]. The motor also incorporates proximity sensors to permit compensation for the radial attractive forces produced in the two motor segment windings. The roll motor produces a maximum of 0.677 Nm of torque in its high excitation mode of operation. The radial force associated with the maximum torque is less than 1.56 N.

Vernier Latches

Five vernier latches, located on the baseplate of the VPA, support the iron rotor for launch and recovery maneuvers. The latches locate and lock the rotor into a center position. Locking the rotor down prevents damage to the MBAs, proximity sensors, and data transfer electronics during maneuvering.

Control Electronics Rack

The control electronic rack was a free standing rack that connected to the VPA through flexible cables, but was intended for laboratory test use only. The electronic assembly contains

*The axial MBA's have had the gap modified from a nominal gap of 7.6mm to 4.31mm in order to suspend the rotor in a one-g environment.

the necessary hardware to drive the actuators, position sensors, and roll motor of the vernier pointing assembly. One of the major goals of the current work was to replace this system with up-to-date hardware, which will be discussed in more detail shortly.

Balance and Testing Fixture

The balance and testing fixture was used to simulate a zero-gravity environment. The apparatus consists of a counter-balancing system to unload the payload mounting plate and vernier pointing assembly in an attempt to simulate orbiter conditions. Tests using this fixture were performed on servo dynamics, decoupling control, stability during cross-axis disturbances, and a variety of other parameters [2,4].

HARDWARE ANALYSIS AND MODIFICATIONS

Magnetic Circuit Analysis

To estimate the force between the MBAs and the rotor the method of Virtual Work was used. Calculation of the change in magnetic energy in a device in which there are moving parts is a simple method of calculating the forces on moving parts in the device [5]. Simply stated, the change in energy, ΔW is equal to the force, F multiplied by the displacement of the body, Δd ($\Delta W = F\Delta d$). Assuming the permeability of Nickel-Iron to be infinite and that the permeability in the air gap remains constant as the body is displaced through a distance Δd , then the energy W is equal to

$$W = \frac{1}{2} \int_v \mu_0 H^2 dV \approx \mu_0 H^2 S \ell$$

where H is the field intensity in the gap, V is the volume, S is the pole face area and ℓ the air gap length (assuming two gaps, as Figure 4). Using Ampere's law for magnetic coils the field intensity can be found from $H2\ell = NI$ where N is the number of turns in the magnetic coils and I is the current in the coils. To calculate the force exerted on the rotor, shown in Figure 4 :

$$W_1 = \mu_0 H_1^2 S \ell_1 = \mu_0 \left(\frac{NI}{2\ell_1} \right)^2 S \ell_1 \quad \text{and} \quad W_2 = \mu_0 \left(\frac{NI}{2\ell_2} \right)^2 S \ell_2$$

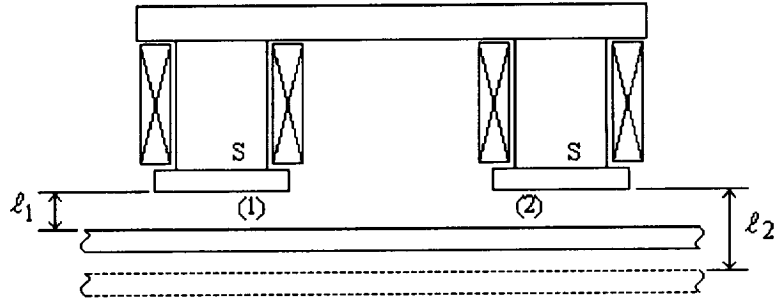

Figure 4 - Magnetic Circuit of an MBA with Movable Rotor.

The force between the rotor and the fixed part of the actuator can then be found by :

$$F = \left| \frac{(W_2 - W_1)}{(\ell_2 - \ell_1)} \right| = \frac{\mu_0 N^2 I^2 S}{4\ell_1 \ell_2}$$

Where $\ell_1 = \ell_2 = 3.41 \text{ mm}$; $S = 1.58 \times 10^{-3} \text{ m}^2$; $N = 1620$. By rearranging the above equation for current, I gives the following :

$$I = \frac{1}{N} \sqrt{\frac{\ell_1 \ell_2 F}{\mu_0 S}} = \frac{1}{N} \sqrt{\frac{g^2 F}{\mu_0 S}}$$

Where $F = \frac{1}{3}M$ and M is equal to the mass of the rotor. The current needed to suspend the rotor at an air gap of $g=3.41 \text{ mm}$ is therefore found to be 0.794 Amps. Alternative calculations using the more traditional circuit model give nearly identical results.

Control Approach

A block diagram of the proposed control system is shown in Figure 5. If the time interval between each input sample is small compared to the time constant of the actuator and process (high sampling rate), the system essentially acts as a continuous system [6]. This allows the A/D and D/A converters to be transparent in the preliminary control system design. The initial controller will be a simple proportional-derivative (PD) type. The plant comprises power amplifiers, the actuators, and the suspended mass. Feedback in the control loop is a measure of suspended mass (rotor) displacement from steady state conditions. In order to predetermine the proportional gain, K_p , and the derivative gain, K_D , accurate plant models are required. This is straightforward except for the MBAs, where the traditional linearized model is employed :

$$F = F_o + \frac{\partial F}{\partial i} i \approx \frac{\mu_0 N^2 I_o^2 S}{g^2} + \frac{2\mu_0 N^2 I_o S}{g^2} i \quad \text{where} \quad I^2 \approx I_o^2 + 2I_o i$$

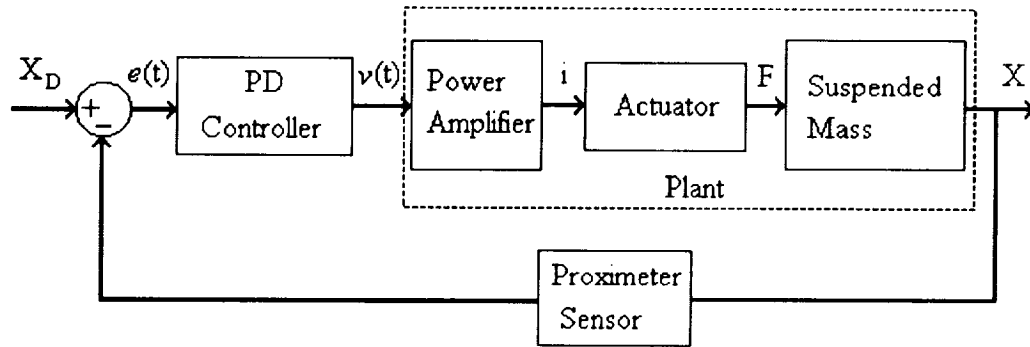

Figure 5 - Block diagram of the ASPS control system.

Figure 6 shows the control system transfer functions :

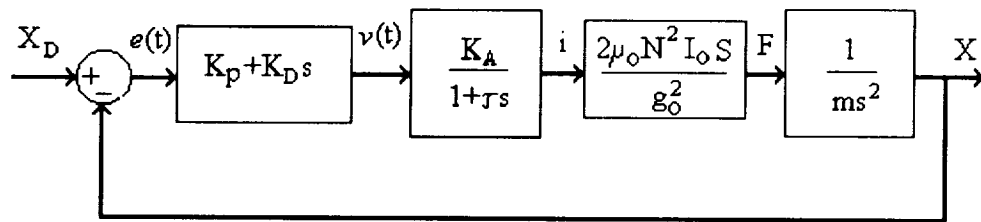

Figure 6 - ASPS component transfer functions

Finally, the transfer function representing the power amplifiers was verified by frequency response analysis of the amplifier using a signal analyzer. A break frequency of approximately 35 Hz was established. Table 1 summarizes all the required constants :

K_A	$1.201 \frac{\text{Amps}}{\text{volt}}$
τ	$.00455 \text{ sec}$
μ_0	$4\pi \times 10^{-7} \frac{\text{H}}{\text{m}}$
N	$810 \frac{\text{turns}}{\text{coil}}$
I_0	1.25 amps^*
S	1641.7 mm^2
g_0	3.41 mm
m	7.19 kg

Table 1 - Summary of constants used in transfer functions.

*Experimentally determined value.

With a ratio of $\frac{K_D}{K_P}=0.1$ the closed-loop transfer function of the system shown in Figure 6 is as follows :

$$K \frac{34.949 s + 349.49}{0.0327 s^3 + 7.19 s^2}$$

The root locus plot of this system shows that the system is stable for a range of K from 0 to 10. An overall gain of 4.5 corresponding to a damping ratio of 0.7 can be determined graphically from Figure 7.

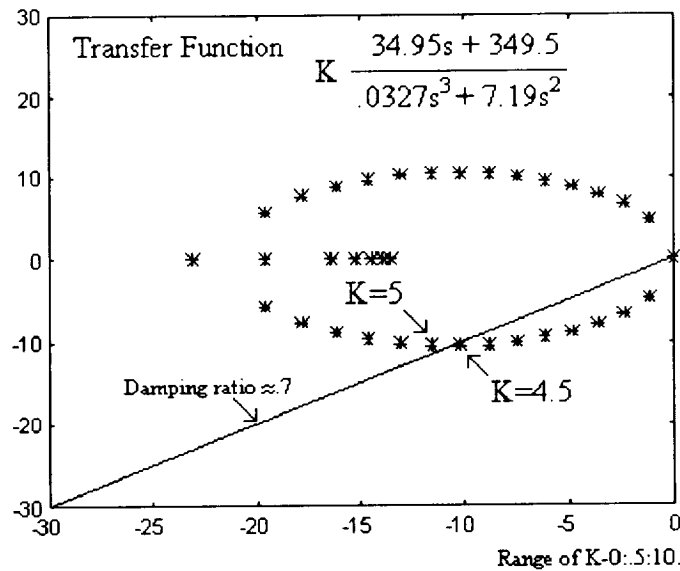

Figure 7 - Root locus for the PD controller.

Modifications to the Magnetic Bearing Assemblies

The first step in recommissioning the VPA was to modify the three axial MBAs so that the rotor could be suspended in a 1-g environment. To accomplish this the gap between the magnetic actuators and the rotor was reduced 54.5%, such that the current needed to suspend the rotor at the new gap was predicted (and verified by testing) to be low enough not to cause overheating of the magnetic coils. To implement the new air-gap, the top plate as shown in Figure 8 was remanufactured with a thickness change from 6.35 mm to 9.53 mm. This new thickness would extend the core material of the magnetic bearing assembly, and reduce the air gap between the top plate and the iron rotor from 7.62 mm to 3.41 mm. The radial magnetic bearing assemblies were not modified.

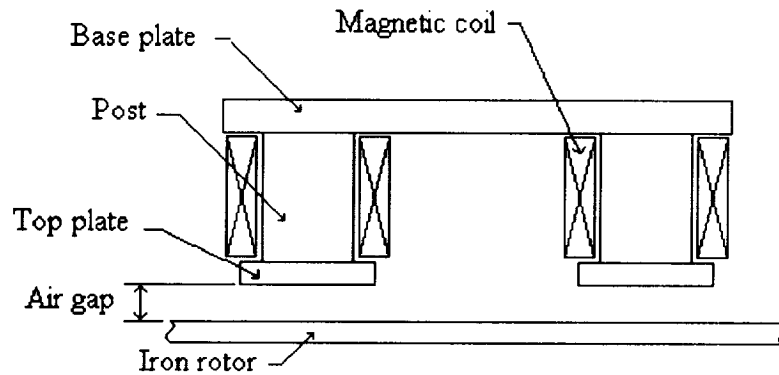

Figure 8 - Magnetic Bearing Assembly.

Digital Controller

The controller hardware comprises a 486DX4-33 PC with 12-bit A/D and D/A boards [7,8]. A counter/timer board was installed to interrupt the main program in order to perform the input/output at a regularly scheduled time interval. The power amplifiers selected to provide power to the magnetic actuators are commercial PWM types [9]. The switching frequency is 22kHz. The controller software was written using Microsoft Quick C and implemented the simple PD controller described earlier. Rate information is estimated by simple differencing of successive position samples. A block diagram of the new hardware is shown in Figure 9.

Each bearing station is controlled independently. This is possible since each has similar dynamics, and the geometry of the system is such that cross-coupling between actuators and system degrees-of-freedom is minimized. It should be noted that extensive coupling is introduced with a payload added, due to the large C.G. offset. Further, the magnetic actuators are quite non-linear, requiring a superior linearizing strategy if operation over the full range of displacements or tilt angles is anticipated. The original control system design incorporated many linearizing, mixing, and feedforward stages for these reasons [2].

OPERATION

The system is operational, with a typical time history from axial MBA station C shown in Figure 10. The large transient around 3 seconds corresponds to the release of the vernier latch at that station. As can be seen, excessive sensor noise currently hampers performance somewhat, but this appears to be due to improper wiring, grounding and shielding practices. Additional signal conditioning is currently being studied.

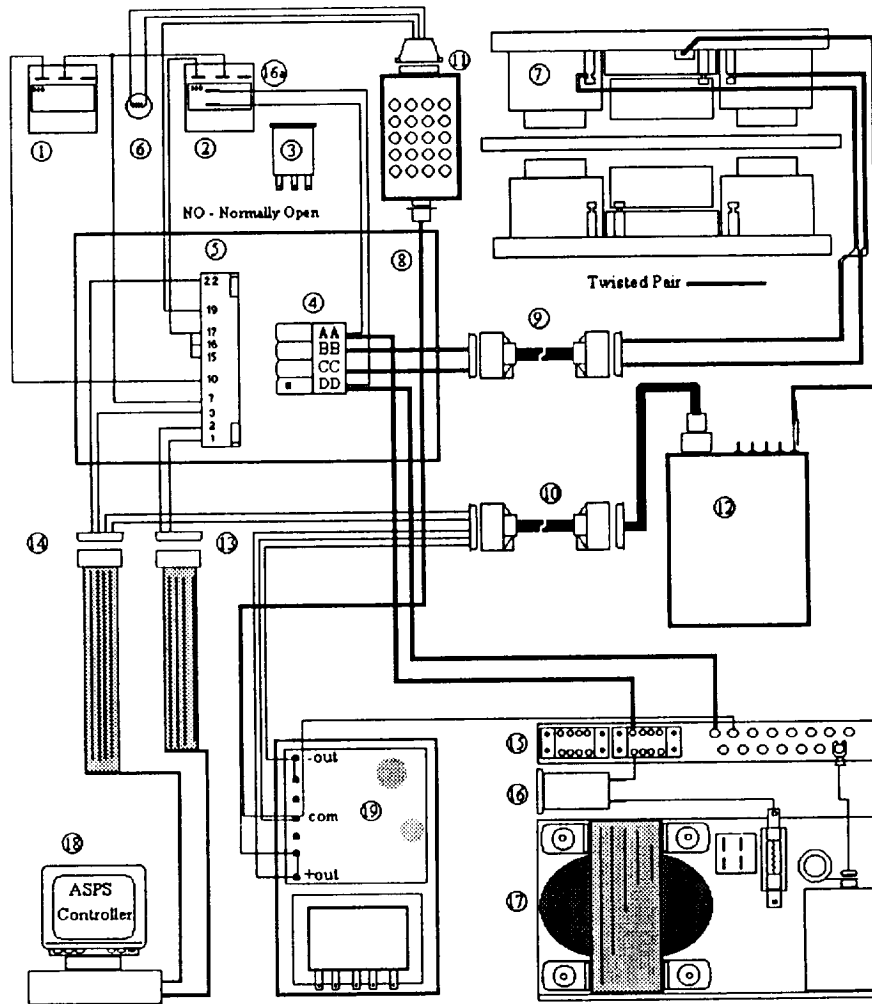

Figure 9 - Schematic Diagram of Revised ASPS Controller and Supporting Hardware

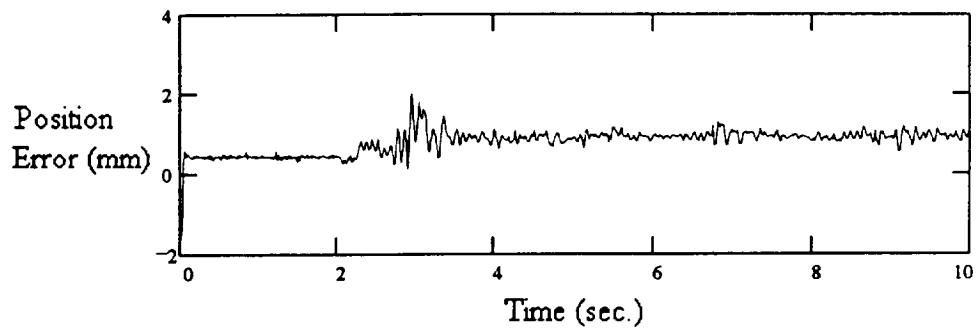

Figure 10 - Typical Time History, MBA station C, showing "launch" transient

CONCLUSIONS

The VPA has been successfully recommissioned and operated with five degree-of-freedom control.

ACKNOWLEDGEMENTS

This work was partially supported by NASA Grant NAG-1-1056, Technical Monitor Nelson J. Groom, and by the NASA/USRA Advanced Design Program administered by the Universities Space Research Association.

REFERENCES

1. Anderson, W.W.; Groom, N.J.; Woolley, C.T.: Annular Suspension and Pointing System. AIAA Journal of Guidance and Control, September-October 1979.
2. Cunningham, D.C., et al.: Design of the Annular Suspension and Pointing System (ASPS). NASA CR-3343, October 1980.
3. Britcher, C.P.; Groom, N.J.: Current and Future Development of the Annular Suspension and Pointing System. 4th International Symposium on Magnetic Bearings, Zurich, Switzerland, August 1994.
4. Sperry Corporation Flight Systems: Final Report - The Development of the ASPS Vernier System. Sperry Corporation Flight Systems, Phoenix, AZ. Contract No.NAS1-15008, June 1983.
5. Ida N.; Bastos, J.P.A.: Electromagnetics and Calculations of Fields. Springer-Verlag, New York, Inc., 1992.
6. Dorf, R.C.: Modern Control Systems, Sixth Edition. Addison-Wesley Publishing Company, 1992.
7. Keithley MetraByte Corporation: Users Guide of the DAS-1402 Data Acquisition Board
8. Keithley MetraByte Corporation: Users Guide of the DDA-06 Data Acquisition Board
9. Copley Controls Corporation: PWM Amplifier Catalog