

527-37
8/2/68

**RESULTS OF A PARAMETRIC STUDY
ON 10,000 LB. AND 50,000 LB.
PERMANENT MAGNET ACTUATORS**

Z. J. J. Stekly, C. Gardner, P. Domigan, C. McDonald, R. A. Farrell
Intermagnetics General Corporation

ABSTRACT

The purpose of this study was to generate design data and complete dynamic performance estimates for a high performance permanent magnet actuator. The basic configuration selected for analysis is an axisymmetric Nd-B-Fe permanent magnet actuator capable of providing force in one direction along its major axis. The actuator consisted of two main axisymmetric components separated by an air gap. The design was optimized for each value of force, gap and magnetic field to yield minimum weight and maximum lift to weight ratio. The following table is indicative of the results achieved.

Force (lbs)	Outer Diameter (inches)	L/W Ratio	Field Strength (T)	Air Gap (inches)
50,000	42.1	9:1	1.0	1.00
	22.0	45:1	1.8	0.25
10,000	10.5	30:1	1.0	0.79
	10.5	60:1	1.5	0.39

The basic conclusions is that, within the parameters considered, the 10,000 lb. and 50,000 lb. actuators are lightweight and compact. As expected for most permanent magnet devices, the smaller ones have higher lift to weight ratios. The question of dynamic performance and the control coil requirements for specific applications remains to be determined.

This work was performed by Field Effects, a division of Intermagnetics General Corporation, under a U.S. Department of Defense subcontract from Lockheed Martin Electric Boat Division, Groton, CT. "Distribution Statement A, Approved for Public Release - Distribution Unlimited."

INTRODUCTION

This study was conducted to determine the characteristics of magnetic suspension systems for vibration isolation. Improved force attenuation and control was the prime motivation for studying magnetic suspension. Although the present effort concentrated on force attenuation, control system analysis was also needed to determine the force attenuation characteristics of magnetic actuators. Field Effects performed a single degree of freedom analysis of a Proportional, Integral, Derivative (PID) controller in order to make a first pass assessment of the force attenuation characteristics of magnetic suspension.⁽¹⁾

CONFIGURATION

Two types of magnetic suspension are possible; attractive and repulsive. A repulsive system is stable in the direction of magnetization but unstable in the transverse directions while the reverse is true of an attractive system.⁽²⁾ A repulsive system requires two magnetic assemblies compared to one for an attractive system and, therefore, is typically more costly to produce. Because of this, the attractive system was selected for study. The configuration selected is an axisymmetric configuration with a pole, permanent magnet material and return yoke in one assembly. A second assembly contains a control coil and lift plate, Figure 1.

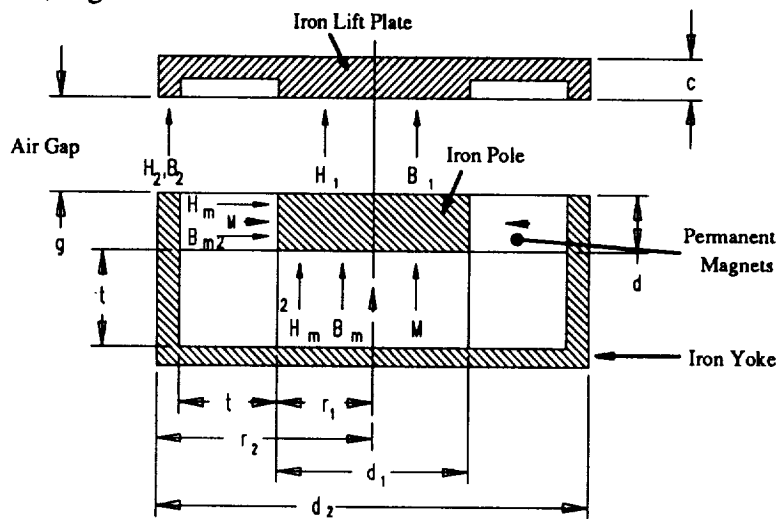

Figure 1. Attractive Actuator cross section and nomenclature

The results of the preliminary dynamic analyses are summarized by Figure 2, which compares the analytical one dimensional force attenuation of a magnetic actuator with

low pass filtered control to a typical rubber device with lift/stiffness ratio of 0.5 inch. This figure indicates that the magnetic actuator provides at least 30 dB more attenuation than the rubber one above frequencies of 10 Hz. It should be noted that this control system has not been optimized and therefore further improvements in the force attenuation characteristics are possible.

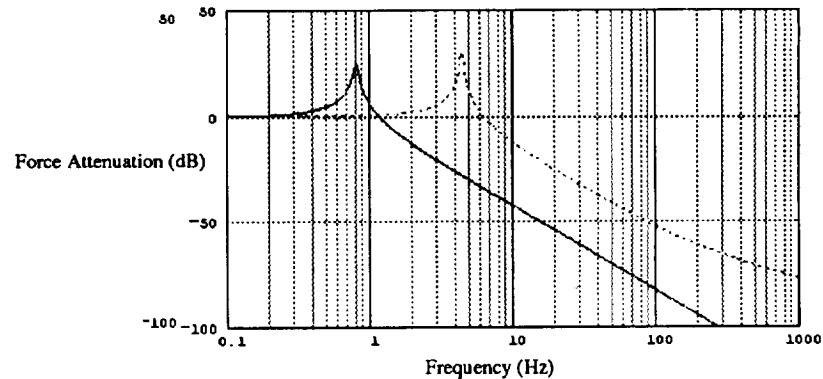

Figure 2. Force Attenuation Comparison Between Typical Rubber Device (dotted) And Magnetic Actuator with low pass filtered PID control (solid).

Equations were derived from first principals⁽³⁾ to establish the relationship between design parameters such as gap and size to desired performance characteristics such as lift force, static stiffness and lift/weight ratio. A discussion of the analysis and equations are contained in the appendix.

10,000 Lb. Actuator Analytical Results

The initial actuator magnetic design focused on an attractive system capable of producing 10,000 lbs. of lift over a range of gaps which varied from 0.25 to 1 inch. The desired stiffness was 20,000 lbs./inch.

An ideal actuator has the following characteristics:

- Low stiffness for good acoustics.
- Large lift capacity.
- Light weight i.e. high lift/weight ratio.
- Small size.
- Large gap for shock mitigation.

As is often the case, these characteristics cannot be achieved without tradeoffs. In this case, optimization is based on minimum weight and diameter. Design curves using the analysis contained in the appendix were generated and are summarized for a 10,000 lb. lift actuator in Figure 3. This figure illustrates lift force, static stiffness (K), gap field and lift to weight ratio as a function of gap and actuator outside diameter. Lines of constant gap magnetic field of 1.0 T and 1.5 T are shown and trends for lift and stiffness as a function of gap and diameter indicated by arrows. The general conclusion is that higher gap fields, i.e., 1.5 T vs. 1.0T, lead to a smaller actuator and greater lift to weight ratios. A nominal operating region is also indicated encompassing actuators with lift to weight ratios ranging from 30-60 to 1. The nominal operating region is somewhat arbitrary but illustrates the range of design parameters that encompass an appropriate variation in the gap while still providing high lift to weight ratio.

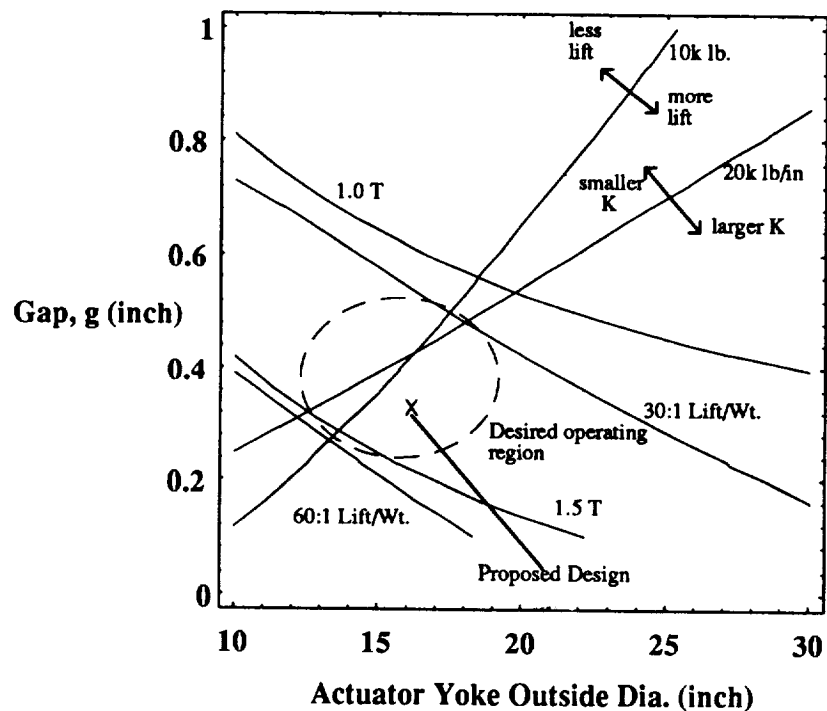

Figure 3. 10,000 Lb. Actuator Preliminary Design Curves.

As an example of design tradeoffs, Figure 3 illustrates that a 16 inch diameter actuator operating at 0.4 inch gap provides 10,000 lbs. of lift and 20,000 lbs./inch of stiffness. With the actuator diameter fixed at 16 inches, an increased gap results in lift, stiffness and lift/weight ratio all decreasing. These curves also indicate that for 10,000 lbs. of lift and a 60:1 lift/weight ratio, static stiffness will be above 20,000 lbs/inch, nominal operating gap will be ~0.2 inches. and the field in the gap will be greater than 1.5 T.

A 10,000 lb. lift actuator design concept for the design point indicated in Figure 3 is shown in Figure 4. The actuator is placed between a platform and the base. The permanent magnets, pole piece, and yoke are located in the upper assembly. The vertical

control coils are integral with the lift plate in the lower assembly. Eight lateral control coils are also located on the sides of the lift plate.

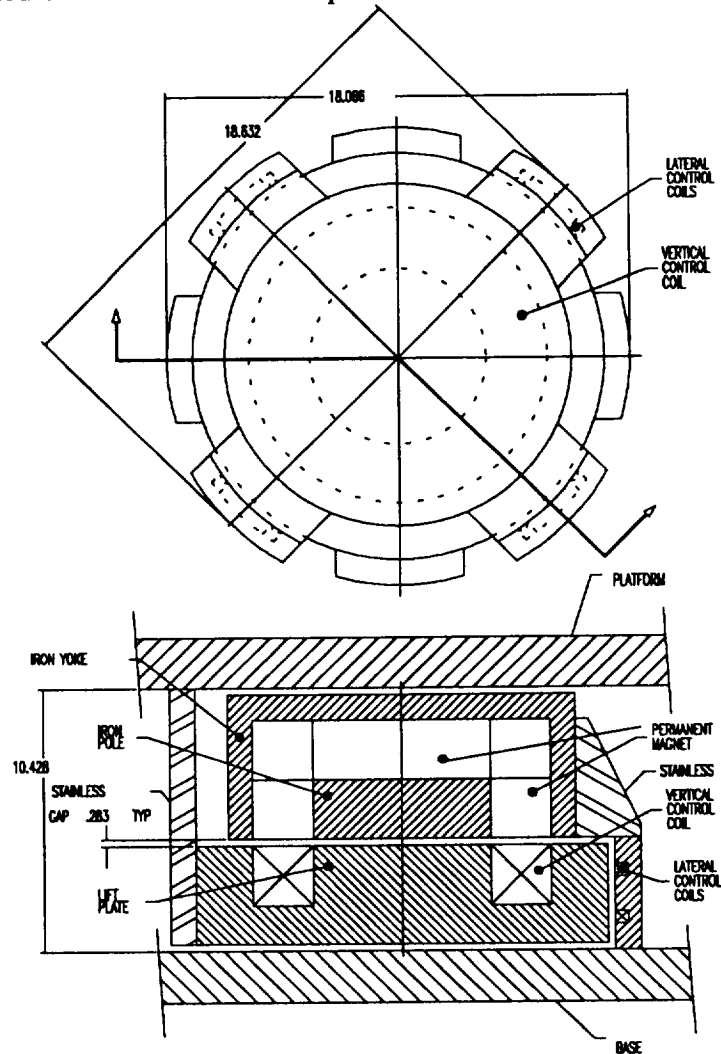

Figure 4. 10,000 lb. Actuator Design Concept.

This actuator concept is 18.7 inches in diameter, 10.4 inches high, has a 0.28 inch nominal gap and gap magnetic field of approximately 1.4 T.

50,000 LB. ACTUATOR ANALYTICAL RESULTS

As a part of this study, design curves for 50,000 lbs. of lift and 100,000 lb./inch stiffness, i.e., the same lift to stiffness ratio as the earlier 10,000 lb. case, were formulated using minimum magnet material as the optimization parameter. This represents a minimum cost approach as the magnet material cost dominates the cost of

the actuator. This approach also considerably simplifies the analysis compared to that used for the previously described 10,000 lb. lift case where minimum weight and diameter were the optimization parameters.

The force attenuation performance for the 50,000 lb. lift designs are essentially the same as shown in Figure 2 since the lift/stiffness ratio gives the same dynamics as the 10,000 lb./20,000 lb./inch case.

Contour curves for 10,000 and 50,000 lbs. lift as a function of gap and actuator diameter for gap magnetic fields of 1.5 and 1.8 T are given in Figures 5 and 6. Note that in these figures, both the 10,000 lb. and 50,000 lb. lift curves are obtained using minimum magnet material as the optimization criteria.

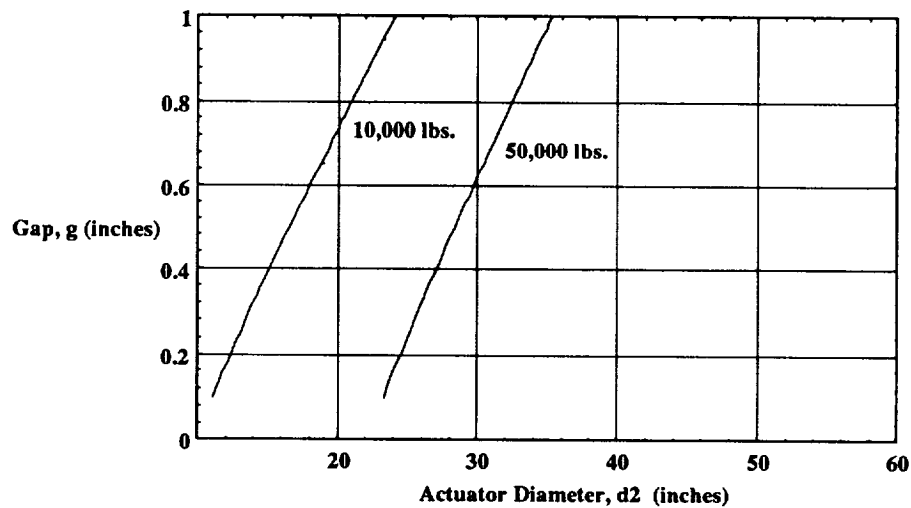

Figure 5. 1.5 T Lift Contours as a Function of Gap and Actuator Diameter.

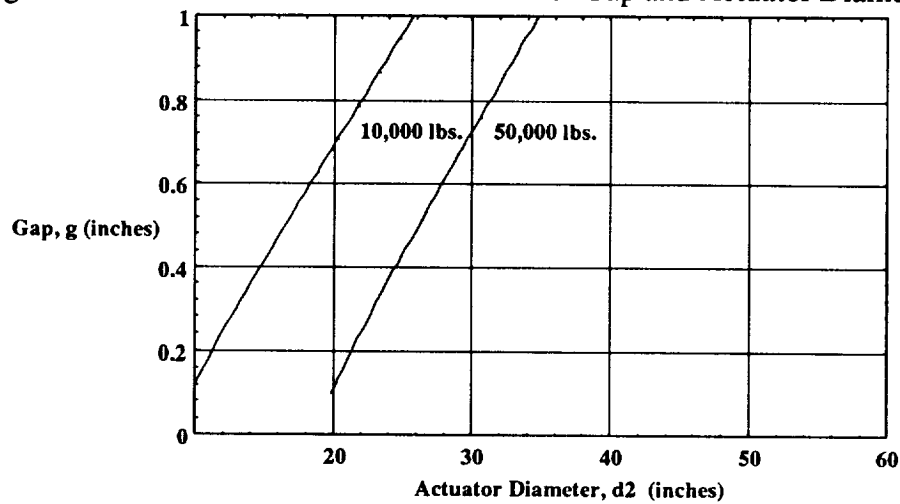

Figure 6. 1.8 T Lift Contours as a Function of Gap and Actuator Diameter.

These figures indicate that for 10,000 lbs of lift there are only minor differences between the 1.5 and 1.8 T curves, probably the result of the large fraction of permanent magnet material dominating magnet sizing. For 50,000 lbs. of lift, increased field yields

smaller actuators for the same gap as expected for designs where larger fractions of iron dominate. This data also demonstrates that large capacity actuators are more efficient from a lift force per unit actuator area standpoints. For example, Figure 5 indicates a 10,000 lb. actuator operating at 0.4 inch gap is approximately 16 inches in diameter while an actuator that provides a 5:1 improvement in lift at the same gap, i.e. 50,000 lbs., is only 1.7 times larger in diameter or 27 inches. The reason for this is that the thickness of permanent magnet material is fixed for a given field and gap. As a consequence, the permanent magnet takes up fractionally less of the area as the loads increase. (See equation A-12 in the appendix).

Figures 7 and 8 indicate stiffness and lift to weight contours respectively for the 1.5 T, 50,000 lb. lift design indicating how these parameters are affected by gap and diameter. Figure 8 shows, as one would expect, that the best lift to weight ratios are achieved with small gap, small diameter actuators.

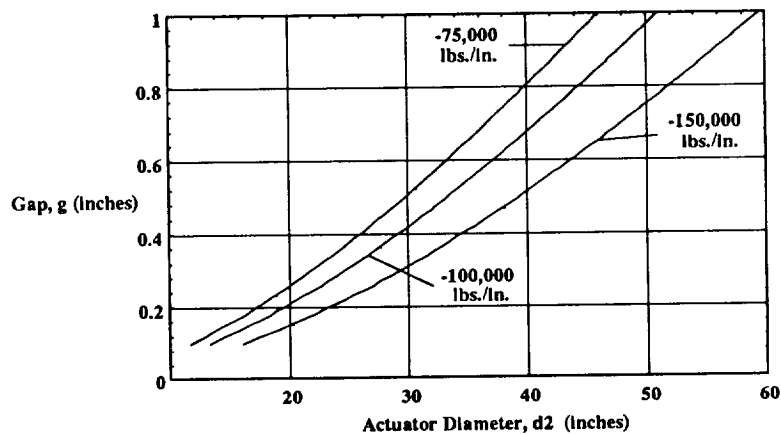

Figure 7. 1.5 T Stiffness Contours as a Function of Gap and Actuator Diameter.

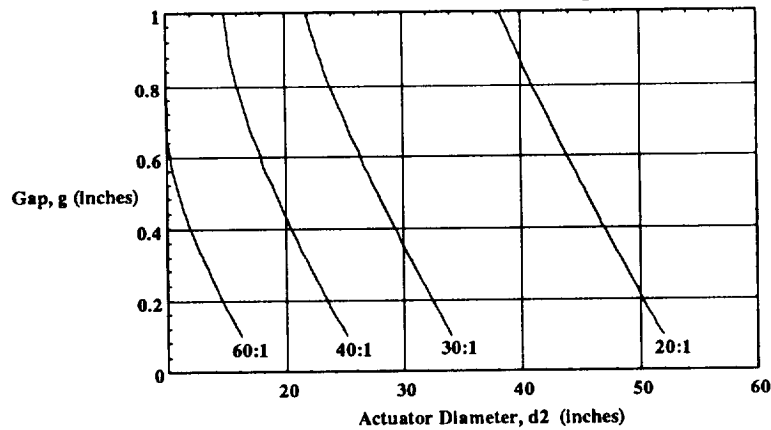

Figure 8. 1.5 T Lift to Weight Contours as a Function of Gap and Actuator Diameter.

Figure 9 indicates lift, stiffness and lift to weight contours for 1.0, 1.5 and 1.8 T gap fields, respectively. The maximum gap field analyzed was 1.8 T since this field is approximately the practical upper limit given the flux carrying capabilities of lower cost

iron alloys. Field Effects has built Nd-Fe-B permanent magnet devices with gap fields as high as 2 T using poles of a more expensive Vanadium Permendur alloy.^(4,9)

Figure 9 clearly shows the tradeoff between gap and lift to weight ratio. At 1.5 T, given a requirement of 50,000 lbs of lift at a 0.1 inch gap, the lift to weight is ~42:1 while at a 1.0 inch gap the lift to weight is ~22:1. 1.0 T actuators have a maximum lift to weight of ~23:1 at 0.1 inch gap and ~10:1 at 1.0 inch gap or about half the performance of the 1.5 T actuator. The 1.8 T performance at 1.0 inch. gap is similar to that at the 1.5 T but has an improved lift to weight ratio (50:1 vs. 42:1) at 0.1 inch gap. Thus, given the flux carrying capacity of existing materials, a compact actuator design will have a gap field between 1.5 and 1.8 T.

Table I summarizes the effect of field and gap on actuator diameter, d_2 , and lift/weight ratio at the nominal 'design point' of 50,000 lb. lift and 100,000 lb./inch stiffness. The conclusion is that, if large gaps are required for shock mitigation reasons, high field actuators can achieve large gaps, i.e. 1 inch, at lift/weight ratios in the 22-26:1 range. Large gaps are not practical with low field actuators as the lift/weight ratio suffers dramatically.

Figure 10 illustrates two 50,000 lb. lift concepts for a 1.5 T attractive actuator designed for 0.25 inch and 1.0 inch nominal gaps. The 0.25 inch gap actuator is 30 inches in diameter, 12.9 inches high and has a lift/weight of 37:1, while the 1.0 inch gap is 41.3 inches in diameter, 20.5 inches high with a lift/weight of 22:1.

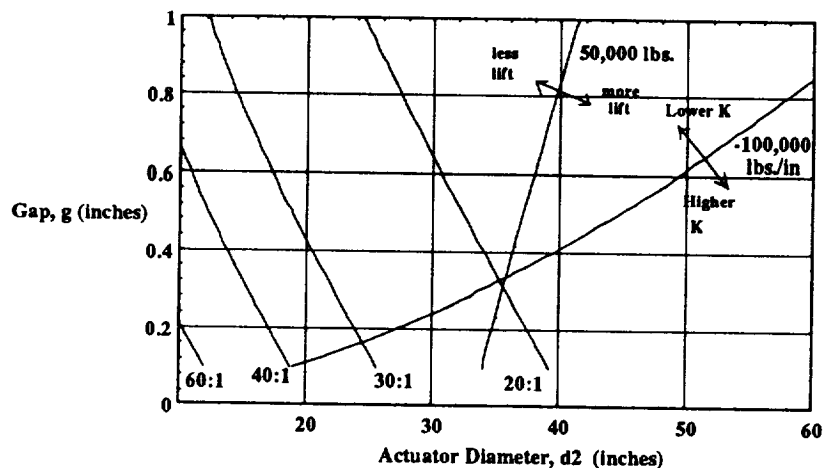

Figure 9 (a). 1.0 T Design Curves.

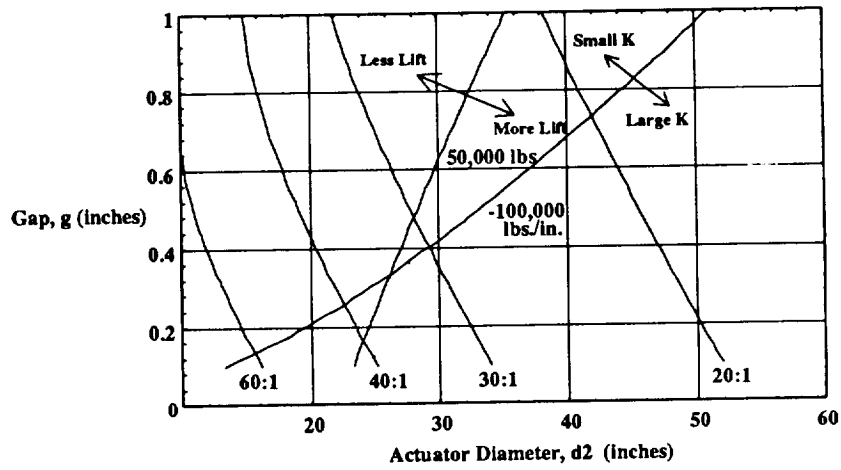

Figure 9 (b). 1.5 T Design Curves.

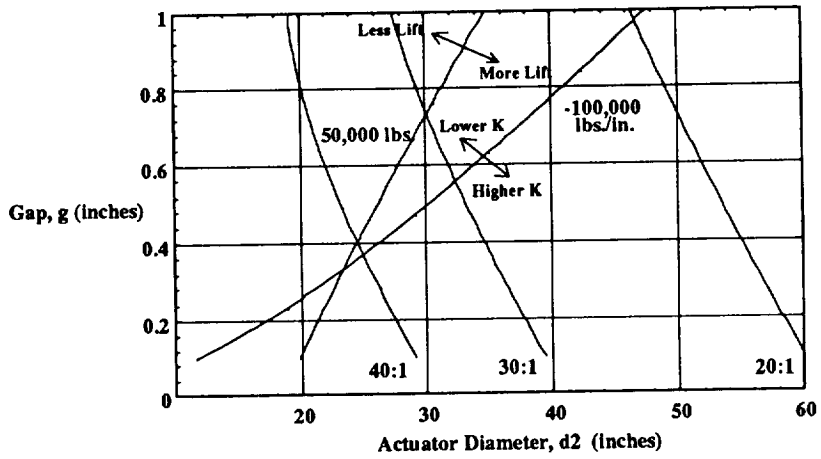

Figure 9 (c). 1.8 T Design Curves.

Table I: 50,000 lbs. and 100,000 lbs./inch Actuator Summary					
Field (T)	Gap, g (in.)	.25	.5	.75	1.0
1.0	d2 (in.)	35	37	39	42
	L/W	22:1	15:1	11:1	9:1
1.5	d2 (in.)	25	28	32	35
	L/W	37:1	30:1	25:1	22:1
1.8	d2 (in.)	22	26	31	35
	L/W	45:1	38:1	30:1	26:1

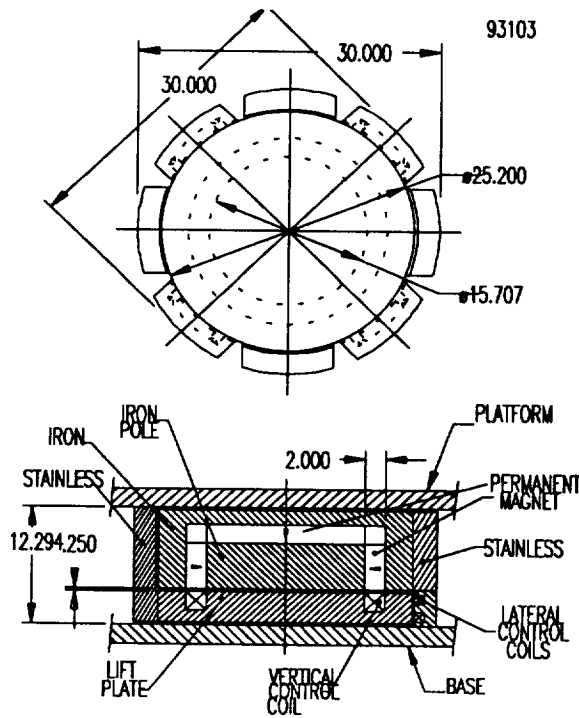

Figure 10a: 1.5 T, 0.25 in. Gap, 50,000 Lb. Lift Actuator Design Concept.

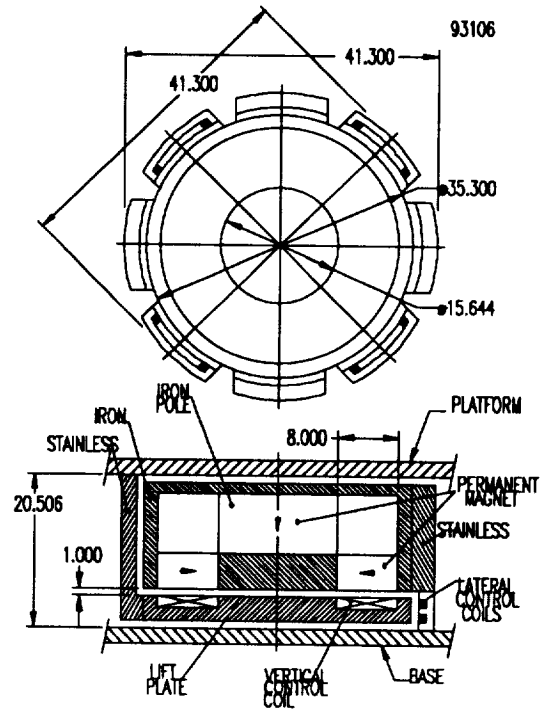
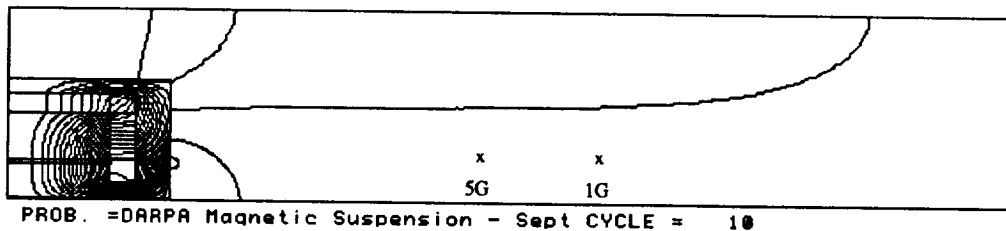

Figure 10b: 1.5 T, 1.0 gap, 50,000 Lb. Lift Actuator Design Concept.

Magnetic fringe fields are of concern for reasons of personnel or equipment exposure. Fields less than 5 Gauss are considered acceptable. PANDIRA[®], a finite difference magnetic analysis code, was used to estimate the fringe field at the gap centerline of the 50,000 lb. actuator design, Figure 11.



PROB. =DARPA Magnetic Suspension - Sept CYCLE = 10

Figure 11. 50,000 lb. Actuator Fringe Field Plot.

The 5 and 1 Gauss points are located at 39.5 and 48.8 inches from the actuator center. The analysis also confirmed the uniformity of magnetic field within the gap at the pole and at the yoke.

CONCLUSIONS

The analysis performed indicates that a magnetic suspension system can provide 30 dB more force attenuation than rubber device above 10 Hz. Design optimization procedures, based on minimum weight and diameter, and a simplified version based on minimum magnet material, have been developed to size actuators and predict performance. In order to maximize actuator Lift to Weight ratio and minimize actuator size, gap field will be in the 1.5-1.8 Tesla range. Concept designs for 50,000 lb. lift actuators operating at 0.25 and 1.0 inch nominal gaps have been presented.

Larger capacity actuators are nearly twice as efficient as smaller actuators from a lift per unit foot print area perspective. For instance to achieve 50,000 lbs. of lift, five (1.5 T, 0.25 inch gap) 10,000 lb. actuators require a foot print of 37 inches by 56 inches while a single 50,000 lbs. actuator (1.5 T, 0.25 inch gap) requires only a 30 inches by 30 inches foot print. The 50,000 lb. actuators are approximately the same size as an equivalent lift capacity rubber device.

This analysis indicates that magnetic suspension is a viable technology based on force attenuation, lift to weight ratio and size. The critical characteristic, as far as the viability of this technology is concerned, is the force attenuation performance. Since magnetic suspension will be more costly than rubber devices, magnetic suspension must significantly improve performance.

ACKNOWLEDGMENTS

The assistance of Ms. Denise Silva and Ms. Julia Saia in preparing this manuscript is gratefully acknowledged.

REFERENCES

1. Katsuhiko, O.: *Modern Control Engineering*, Electrical Engineering Series, Prentice-Hall, Englewood Cliffs, NJ, 1970
2. Kraus, J.D.: *Electromagnetics*, McGraw-Hill, NY, 1984
3. Reitz, J. R.; Milford, F. J.; and Christy, R.W.: *Foundations of Electromagnetic Theory*, Addison Wesley Publishing Co., 1992.
4. Stekly, Z.J.J.; Gardner, C.; Baker, J.; Domigan, P.; Hass, M.,;McDonald, C.; and Wu, C.: *Design and Performance of 2T Permanent Magnet Wiggler for the Stanford Synchrotron Radiation Laboratory* presented at Synchrotron Radiation Instrumentation 1995, Argonne, IL.
5. Stekly, Z.J.J.; Gardner, C.; Domigan, P.: *A 2T Full Scale High Performance Periodic Permanent Magnet Model for Attractive (228KN) and Repulsive Maglev*, to be presented at NASA Magnetic Suspension Conference 1995, Tallahassee, FL.
6. POISSON, Super Fish Reference Manual LA-UR-87-126 LANL Code Group MS H829, LANL, N.M. Jani, 1987

APPENDIX

A-1 Magnetic and Force Analysis

The equations governing actuator design are discussed in this appendix. Figure A-1 illustrates a cross section of a generic actuator and the nomenclature used.

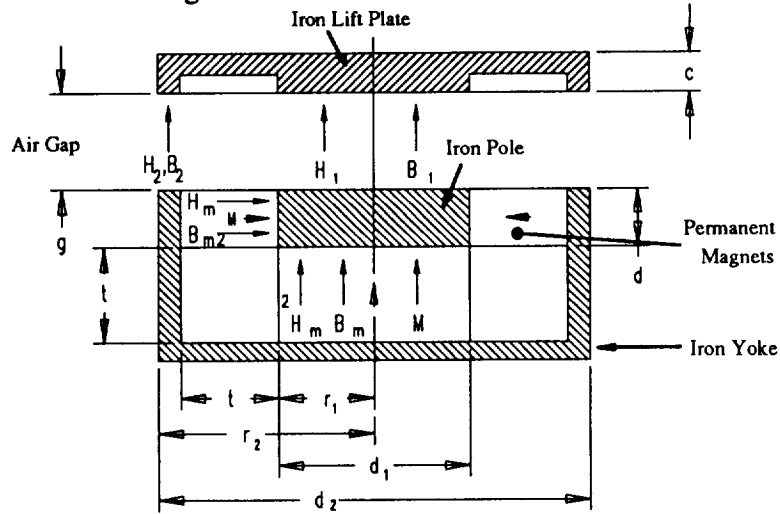

Figure A-1: Attractive Actuator cross section and nomenclature.

The location of the magnetic fields B_1 , H_1 and B_2, H_2 in the gap and B_m, H_m within the permanent magnet material are indicated in the figure. The areas A_1, A_2, A_3 , defined below, are for the inner pole, outer yoke and total for the permanent magnet material, respectively. The three basic magnetic equations involve continuity of magnetic flux, application of Ampere's Law and the relationship between fields and magnetization within the permanent magnet:

$$B_1 A_1 = B_2 A_2 = B_m A_3 \quad [A1]$$

$$H_{\text{net}} = - \frac{[B_1 + B_2]g}{\mu_0} \quad [A2]$$

$$B_m = \mu_0 (H_m + M_m) \quad [A3]$$

The above equations assume that the iron has a very high magnetic permeability. Using all three equations to eliminate B_2, B_m , and H_m results in:

$$B_1 = \frac{\mu_o M}{\frac{g}{t} \left(1 + \frac{A_1}{A_2}\right) + \frac{A_1}{A_3}} \quad [A4]$$

where:

subscripts:

M = magnetization

m = magnetic material

B_1 = pole gap flux

1 = inner pole

t = magnet thickness

2 = outer yoke

r_1 = pole radius

d = pole depth

r_2 = outer radius of yoke

$A_3 = \pi r_1(r_1 + 2d)$, surface area magnet

$A_1 = \pi r_1^2$, pole area

$A_2 = \pi(r_2^2 - (r_1 + t)^2)$ yoke area

g = air gap

The attractive force is equal to: $F = \frac{B_1^2}{2\mu_o} A_1 + \frac{B_2^2}{2\mu_o} A_2$ [A5]

This is equal to the magnetic pressure at the pole $B^2/2\mu_o$ times the appropriate area which can be simplified to: $F = \frac{B_1^2}{2\mu_o} A_1 [1 + A_1/A_2]$ [A6]

the stiffness, K is obtained by:

$$K = \frac{\partial F}{\partial g} = \frac{B_1}{\mu_o} A_1 [1 + A_1/A_2] \frac{\partial B_1}{\partial g} \quad [A7]$$

Performing the derivative indicated using equation A4 for B_1 , substituting and simplifying results in:

$$K = \frac{F(1 + A_1/A_2)}{t} \cdot \frac{2B_1}{\mu_o M} \quad [8]$$

Initially for the 10,000 lb. actuator design curves were obtained by choosing a value for the magnetization, $\mu_o M$ typical for Nd-B-Fe 1.1T magnet material and varying the remaining variables, based on experience, to determine B_1 . The lift force, F and actuator stiffness, K were then calculated using the above equations. The iron pole, yoke, and lift plate dimensions were then determined by assuming the field in the iron was the same as that in the gap.

The lift to weight ratio could then be easily calculated as the ratio of F to actuator weight using the following:

$$L/W = \frac{F}{\rho_m V_m + \rho_{Fe} V_{Fe}} \quad [A8]$$

where:

ρ_m = magnet density

ρ_{Fe} = iron density

V_m = magnet volume

V_{Fe} = iron volume

Because of the number of independent variables involved, this process was time consuming. It was also difficult to determine when an actuator design was "optimal". Therefore, a simplified design process was desirable.

A-2 Design Optimization

A designer wants to know what the lift, stiffness and lift/weight is as a function of gap and actuator diameter. Because of saturation effects, practical actuator designs will have a maximum gap field, B_1 of between 1 and 2 Tesla. The designer is also limited by the properties of today's materials therefore, M is also known. This line of reasoning led us to conclude that we needed a design approach such that given the independent variables, B_1 , M , r_2 and g , we could optimize the pole height, d and the magnet thickness, t .

The approach selected sought to minimize the volume of magnet material in the actuator. This simplified approach seeks to minimize actuator cost by minimizing the amount of the most expensive component of the actuator, the magnet material. We begin by approximating the magnet volume, V_m as the product of its surface area, A_3 and thickness, t as shown by:

$$V_m = A_3 t \quad [A9]$$

We now substitute into [A4] to get:

$$V_m = \frac{A_3 g \left(1 + \frac{A_1}{A_2} \right)}{\left(\frac{M}{B_1} - \frac{A_1}{A_3} \right)} \quad [A10]$$

Next we minimize V_m by taking the appropriate derivative of V_m and setting it equal to zero to get:

$$A_3 = \frac{2 A_1 B_1}{M} \quad [A11]$$

To get an expression for t , we substitute [A9] and [A10] in [A11] and solve for t , the thickness of permanent magnet material:

$$t = \frac{2 B_1 g \left(1 + \frac{A_1}{A_2} \right)}{M} \quad [A12]$$

