

110285  
97723

NASA Technical Memorandum 110285

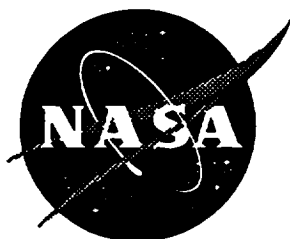

# The Kirchhoff Formulas for Moving Surfaces in Aeroacoustics - The Subsonic and Supersonic Cases

F. Farassat  
*Langley Research Center, Hampton, Virginia*

September 1996

National Aeronautics and  
Space Administration  
Langley Research Center  
Hampton, Virginia 23681-0001



# **THE KIRCHHOFF FORMULAS FOR MOVING SURFACES IN AEROACOUSTICS - THE SUBSONIC AND SUPERSONIC CASES**

F. Farassat  
*NASA Langley Research Center, Hampton, VA 23681, USA*

## **ABSTRACT**

One of the active areas of computational aeroacoustics is the application of the Kirchhoff formulas to the problems of the rotating machinery noise prediction. The original Kirchhoff formula was derived for a stationary surface. In 1988, Farassat and Myers derived a Kirchhoff Formula obtained originally by Morgans using modern mathematics. These authors gave a formula particularly useful for applications in aeroacoustics. This formula is for a surface moving at subsonic speed. Later in 1995 these authors derived the Kirchhoff formula for a supersonically moving surface. This technical memorandum presents the viewgraphs of a day long workshop by the author on the derivation of the Kirchhoff formulas. All necessary background mathematics such as differential geometry and multidimensional generalized function theory are discussed in these viewgraphs. Abstraction is kept at minimum level here. These viewgraphs are also suitable for understanding the derivation and obtaining the solutions of the Ffowcs Williams-Hawkings equation. In the first part of this memorandum, some introductory remarks are made on generalized functions, the derivation of the Kirchhoff formulas and the development and validation of Kirchhoff codes. Separate lists of references by Lyrintzis, Long, Strawn and their co-workers are given in this memorandum. This publication is aimed at graduate students, physicists and engineers who are in need of the understanding and applications of the Kirchhoff formulas in acoustics and electromagnetics.

## **INTRODUCTION**

When Ffowcs Williams and Hawkings published their now famous paper on the noise from moving surfaces in 1969 [1], they used a level of mathematical sophistication unfamiliar to engineers who would later be the main users of this work. Advanced generalized function theory and differential geometry were employed by these authors to derive the Ffowcs Williams-Hawkings (FW-H) equation and to obtain some important qualitative results in this paper. The subject of generalized functions is very abstract, particularly as described in books written by mathematicians. The level of differential

geometry needed in acoustics is, however, basic and at the level essentially fully developed by the end of the nineteenth century. Both of these subjects are not emphasized in engineering education. It is possible to teach advanced generalized function theory to engineers if some of the abstractions are left out initially. One needs to learn how to work with multidimensional Dirac delta functions and their derivatives concentrated on moving surfaces, i.e. with support on moving surfaces. This goal can be achieved.

This technical memorandum is on the derivation of the Kirchhoff formulas for moving surfaces. The main part of this memorandum is the copies of the viewgraphs based on lectures delivered by the author in the Workshop on Kirchhoff Formulas for Moving Surfaces at NASA Langley Research Center on February 15, 1995 (see Appendix). Attempt was made to present all the mathematical machinery needed in the derivation of Kirchhoff formulas. One of the publications of the author [2], NASA TP-3428 (May 1994), should also be consulted, if needed, to fill in some details. The author and M. K. Myers have published two papers on the derivation of Kirchhoff formula for moving surfaces [3, 4] which should be easily comprehended by the readers reading the material in the Appendix.

Below we briefly introduce the concept of Generalized Functions. Then we discuss the derivation of the subsonic and supersonic Kirchhoff formulas. Finally we make some remarks on the development and validation of codes based on the Kirchhoff formulas.

## **GENERALIZED FUNCTIONS**

Our main reference for this section is NASA TP-3428 [2]. To derive the Kirchhoff formulas for moving surfaces, we need to learn how to manipulate multidimensional Dirac delta functions and their derivatives. Some knowledge of differential geometry and tensor analysis is also essential. In addition to [2], we give some other useful references on generalized functions as well as on differential geometry and tensor analysis in this paper [5-13]. To learn about generalized functions, we need a *change of paradigm* in the way we look at ordinary functions. Ordinary functions are locally (Lebesgue) integrable functions, i.e., functions that have a finite integral over any finite interval. This change of paradigm is actually very familiar in mathematics. For

example, learning about fractions, negative numbers and complex numbers involves a change of paradigm although we are not told that the change is occurring.

How do we think of an ordinary function  $f(x)$ ? We think of this function as a table of ordered pairs  $(x, f(x))$ . A graph of a function is a plot of this table. In generalized function theory, we need to work with mathematical objects such as the Dirac delta "function"  $\delta(x)$  with the sifting property

$$\int_{-\infty}^{\infty} \phi(x)\delta(x)dx = \phi(0) \quad (1)$$

It can be shown that no ordinary function has this property. The Dirac delta function is an example of a generalized function which is not an ordinary function. To include  $\delta(x)$  and other such useful but strange objects in mathematics, we change our method of thinking about functions as follows. Suppose we take a space of functions  $D$  which will be called *test function space*. We will be more specific about  $D$  below. Now given an ordinary function  $f(x)$ , let us define the *functional*

$$F[\phi] = \int_{-\infty}^{\infty} f\phi dx, \quad \phi \in D. \quad (2)$$

If we take the space  $D$  large enough, then there is a possibility that the table of functional values  $F[\phi]$  where  $\phi \in D$  can identify  $f(x)$ . This is actually true if we take the space  $D$  as the space of all  $C^\infty$  functions which are identically zero beyond a bounded interval, i.e., with compact support. Therefore, the new paradigm of viewing a function is: *think of the function  $f(x)$  in terms of the table  $\{F[\phi], \phi \in D\}$* . We can show that this table includes an uncountable number of elements.

Next, one shows that the functional  $F[\phi]$  given by eq. (2) is *linear* and *continuous* for an ordinary function  $f(x)$  [2, 7-9]. We ask whether all continuous linear functionals are produced by ordinary functions from eq. (2). The answer is no. For example, the functional

$$\delta[\phi] = \phi(0) \quad \phi \in D \quad (3)$$

is linear and continuous. Therefore, the class of linear and continuous functionals is larger than the class generated by ordinary functions through eq. (2). Now, using our new paradigm of thinking of a function as a table generated by the functional rule we say:

*a generalized function is identified by the table produced using a continuous linear functional on space  $D$ .*

By an abuse of terminology, we say that:

*generalized functions are continuous linear functionals on space  $D$ .*

By this definition the functional in eq. (3) is (represents) the Dirac delta function! Note that each continuous linear functional on space  $D$  produces (represents, identifies, gives) *one* generalized function. Ordinary functions then become a subset of generalized functions called *regular* generalized functions. Other functions are called *singular* generalized functions.

Next the operations on ordinary functions are extended to all generalized functions in such a way that they are equivalent to the old definitions when applied to ordinary functions. To do this, one should write the operation in the language of functionals on space  $D$ . For example, the derivative of generalized function  $F[\phi]$  is defined by

$$F'[\phi] = -F[\phi'] \quad (4)$$

In this way, many operations on ordinary functions can be extended to generalized functions [2, 5-9].

Finally, we mention here that the space of generalized functions on  $D$  is called  $D'$ . For any singular generalized function  $F[\phi]$ , we use eq. (2) with a *symbolic* function  $f(x)$  under the integral sign. Here the integral does not represent an ordinary integral but stands for the rule specified by  $F[\phi]$ . For example,  $\delta(x)$  is a symbolic function which is interpreted as follows. Interpret  $\int \delta(x)\phi(x) dx$  as  $\delta[\phi] = \phi(0)$  for all  $\phi \in D$ , i.e., in our new way of looking at functions as a table of functional values on space  $D$

$$\delta(x) \equiv \{\phi(0), \phi \in D\} \quad . \quad (5)$$

Of utmost importance to us are delta functions and their derivatives with support on a surface  $f = 0$ . Here  $f = f(\bar{x})$  or  $f = f(\bar{x}, t)$ . We give the following two results [2] assuming that  $|\nabla f| = 1$  on  $f = 0$ , which is always possible:

$$\int \phi(\bar{x}) \delta(f) d\bar{x} = \int_{f=0} \phi dS \quad (6)$$

$$\int \phi(\bar{x}) \delta'(f) d\bar{x} = \int_{f=0} \left[ -\frac{\partial \phi}{\partial n} + 2H_f \phi \right] dS \quad (7)$$

where  $H_f$  is the local mean curvature of the surface  $f = 0$  with  $dS$  the element of the surface area. Also if the function  $f(\bar{x})$  has a discontinuity across a surface  $g(\bar{x}) = 0$  with the jump defined as

$$\Delta f = f(g = 0_+) - f(g = 0_-), \quad (8)$$

then

$$\bar{\nabla} f = \nabla f + \Delta f \nabla g \delta(g) \quad (9)$$

where  $\bar{\nabla} f$  is the generalized gradient of  $f(\bar{x})$  (see [2]). Finally, we mention here that the Green's function method is valid for finding solutions of differential equations with discontinuities (weak solutions) provided that all derivatives in the differential equation are viewed as generalized derivatives.

### THE KIRCHHOFF FORMULAS FOR MOVING SURFACES

Assume that  $f(\bar{x}, t) = 0$  is the moving Kirchhoff surface defined such that  $|\nabla f| = 1$  on this surface. Let  $\phi$  satisfy the wave equation in the exterior  $\bar{\Omega}$  of  $f = 0$ , i.e.,

$$\square^2 \phi = 0 \quad \bar{x} \in \bar{\Omega} \quad (10)$$

Extend  $\phi$  to the entire unbounded space as follows, calling the extended function  $\tilde{\phi}$

$$\tilde{\phi} = \begin{cases} \phi(\bar{x}, t) & \bar{x} \in \bar{\Omega} \\ 0 & \bar{x} \notin \bar{\Omega} \end{cases} \quad (11)$$

The governing equation for deriving the Kirchhoff formula for moving surfaces is then found by applying the generalized wave operator (D'Alembertian) to  $\tilde{\phi}$  to get [2-4]:

$$\bar{\square}^2 \tilde{\phi} = -\left(\phi_n + \frac{1}{c} M_n \phi_t\right) \delta(f) - \frac{1}{c} \frac{\partial}{\partial t} [M_n \phi \delta(f)] - \nabla \cdot [\phi \bar{n} \delta(f)] \quad (12)$$

where  $M_n = v_n / c$  is the local normal Mach number on  $f = 0$ ,  $\phi_n = \partial \phi / \partial n$  and  $\phi_t = \partial \phi / \partial t$ .

We can now apply the Green's function method for the wave operator in the unbounded space to eq. (11) to find the Kirchhoff formula for subsonically moving surfaces [3]. The formula involves a Doppler singularity making it inappropriate for a supersonically moving surface. For supersonic surfaces, we derive the Kirchhoff formula for an open surface (e.g. a panel). The reason is that the Kirchhoff surface is usually divided into panels and the formula is applied individually to each panel. The subsonic formula, applies to both open and closed surfaces. However, the supersonic formula differs for open and closed surfaces. If the formula for an open surface is known, obtaining the formula for a closed surface is trivial.

The governing equation for deriving the supersonic Kirchhoff formula for a panel is

$$\bar{\square}^2 \tilde{\phi} = -\left(\phi_n + \frac{1}{c} M_n \phi_t\right) H(\tilde{f}) \delta(f) - \frac{1}{c} \frac{\partial}{\partial t} [M_n \phi H(\tilde{f}) \delta(f)] - \nabla \cdot [\phi \bar{n} H(\tilde{f}) \delta(f)] \quad (13)$$

where  $H(\tilde{f})$  is the Heaviside function,  $\tilde{f}$  is a function such that  $\tilde{f} > 0$  on the panel and  $f = \tilde{f} = 0$  defines the edge of the panel. The derivatives on the right side of eq. (13) are brought inside to get three source terms involving  $H(\tilde{f}) \delta(f)$ ,  $H(\tilde{f}) \delta'(f)$  and  $\delta(\tilde{f}) \delta(f)$  [4]. The solutions of the wave equation with these kinds of sources are given by the author [2]. The Kirchhoff formula for a supersonically moving surfaces using the above method was derived and presented by Farassat and Myers [4]. It is a



particularly simple and straightforward result and easy to apply. This formula requires the mean curvature  $H_F$  of the surface  $\Sigma: F(\bar{y}; \bar{x}, t) = [f(\bar{y}, \tau)]_{ret}$ . We give the formula for calculation of  $H_F$  in the Appendix in terms of the geometric and kinematic parameters of the Kirchhoff surface  $f = 0$ .

## **SOME REMARKS ON DEVELOPMENT AND VALIDATION OF KIRCHHOFF CODES**

The development of a Kirchhoff code requires a good subroutine for retarded time calculation if the Kirchhoff surface is rotating. The possibility of multiple emission times for a supersonic panel complicates retarded time calculation, particularly for two nearly equal emission times. If the Kirchhoff surface is not selected properly for the supersonic formula, there is the possibility of a singularity [4]. This singularity can be avoided as suggested by Farassat and Myers [4] or by using two different Kirchhoff surfaces for different intervals of the observer time. There is a fool-proof test of the Kirchhoff code that must not be ignored by code developers. Both of the Kirchhoff formula for moving surfaces, as well as that for a stationary surface, are written such that  $\bar{\phi} = 0$  inside a *closed* surface. Therefore, to test a Kirchhoff code, use a point source inside the closed surface and specify  $\phi$ ,  $\dot{\phi}$  and  $\phi_n$  analytically on the Kirchhoff surface  $f = 0$ . If the observer is now put *anywhere* inside  $f = 0$  and  $\bar{\phi} \neq 0$ , then there is a bug in the code. One must rule out conceptual misunderstanding of the parameters in the formulation first. It is recommended that one should be familiar with the complete details of the derivation of the Kirchhoff formulas to avoid conceptual misunderstanding.

There have been many derivations of the Kirchhoff formula for uniform rectilinear motion of the Kirchhoff surface [14, 15]. These formulas do not have the generality of Morgans formula derived and rewritten in a new form using modern mathematics by Farassat and Myers [3]. Myers and Hausmann [16] were among the first to use the new Kirchhoff formula in aeroacoustics. Other researchers include Lyrintzis, Long, Strawn and Di Francescantonio [17]. We give separately the publications of Lyrintzis, Long, Strawn and their co-workers.

## **CONCLUDING REMARKS**

The availability of high resolution aerodynamics and turbulence simulation make the Kirchhoff formulas discussed here attractive in aeroacoustics. The mathematics for derivation of these formulas have been under development in the last decade and are

well within the reach of modern engineers. The final form of the formulas are simple and relatively easy to apply. The present paper is written as a guide to understanding the mathematical derivation as well as application of these results.

The viewgraphs in the Appendix give all the necessary mathematical background for the derivation of the Kirchhoff formulas. Note that the mathematical part of the Appendix is also suitable for understanding the derivation and the solutions of the Ffowcs Williams-Hawkings equation. This publication is aimed at graduate students, physicists and engineers who are in need of the understanding and applications of the Kirchhoff formulas in acoustics and electromagnetism.

## REFERENCES

1. Ffowcs Williams, J. E., and Hawkings, D. L., "Sound Generated by Turbulence and Surfaces in Arbitrary Motion," *Philosophical Transactions of the Royal Society*, Vol. A264, 1969, pp. 321-342.
2. Farassat, F., "Introduction to Generalized Functions With Applications in Aerodynamics and Aeroacoustics," NASA TP-3428, May 1994 (corrected April 1996). Download from Langley Technical Report Server, <ftp://techreports.larc.nasa.gov/pub/techreports/larc/94/tp3428.ps.Z>.
3. Farassat, F., and Myers, M. K., "Extension of Kirchhoff's Formula to Radiation from Moving Surfaces," *Journal of Sound and Vibration*, 123(3), 1988, pp. 451-460.
4. Farassat, F., and Myers, M. K., "The Kirchhoff Formula for a Supersonically Moving Surface," Presented at First Joint CEAS/AIAA Aeroacoustics Conference (16th AIAA Conference), June 1995, Munich, Germany.
5. Lighthill, M. J., *Introduction to Fourier Analysis and Generalized Functions*, Camb. Univ. Press, 1964.
6. Jones, D. S., *The Theory of Generalized Functions*, 2nd ed., Camb. Univ. Press, 1982.
7. Gel'fand, I. M., and Shilov, G. E., *Generalized Functions*, Vol. 1, *Properties and Operations*, Academic Press, 1964.
8. Kanwal, R. P., *Generalized Functions - Theory and Technique*, Academic Press, 1983.
9. Strichartz, R. S., *A Guide to Distribution Theory and Fourier Transforms*, CRC Press, 1994.

10. Struik, D. J., *Lectures on Classical Differential Geometry*, 2nd ed., Dover Books, 1988.
11. Kreyszig, E., *Differential Geometry*, Dover Books, 1991.
12. McConnell, A. J., *Applications of Tensor Analysis*, Dover Books, 1957.
13. Aris, R., *Vectors, Tensors, and the Basic Equations of Fluid Mechanics*, Dover Books, 1989.
14. Lyrantzis, A. S., and George, A. R., "Transonic Blade -Vortex Interactions: The Far Field," paper presented at the American Helicopter Society National Specialists' Meeting on Aerodynamics and Aeroacoustics, 25-27 February 1987, Arlington, Texas.
15. Morino, L., "Boundary Integral Equations in Aerodynamics," *Applied Mechanics Review*, 46, 1993, pp. 445-466.
16. Myers, M. K., and Hausmann, J. S., "On the Application of the Kirchhoff Formula for Moving Surfaces," *Journal of Sound and Vibration*, 139(1), 1990, pp. 174-178.
17. Di Francescantonio, P., "A Supersonically Moving Kirchhoff Surface Method for Delocalized High Speed Rotor Noise Prediction," AIAA-96-1708, 2nd CEAS/AIAA Aeroacoustics Conference, May 6-8, 1996, State College, Pa.

## **PUBLICATIONS OF A. S. LYRINTZIS AND CO-WORKERS**

### **Journal/Refereed Papers**

- LY1. George, A. R., and Lyrantzis, A. S., "Acoustics of Transonic Blade-Vortex Interactions," *AIAA Journal*, Vol. 26, No. 7, July 1988, pp. 769-776.
- LY2. Lyrantzis, A. S., and George, A. R., "Study of Transonic Blade-Vortex Interaction Noise," *Noise Control Engineering Journal*, Vol. 32, No. 3, May-June 1989, pp. 105-109.
- LY3. Lyrantzis, A. S., and George, A. R., "Far-Field Noise of Transonic Blade-Vortex Interactions," *American Helicopter Society Journal*, Vol. 34, No. 3, July 1989, pp. 30-39.
- LY4. Lyrantzis, A. S., and George, A. R., "The Use of Kirchhoff Method in Acoustics," *AIAA Journal*, Vol. 27, No. 10, Oct. 1989, pp. 1451-1453.
- LY5. Lyrantzis, A. S., and Xue, Y., "A Study of the Noise Mechanisms of Transonic Blade-Vortex Interactions," *AIAA Journal*, Vol. 29, No. 10, Oct. 1991, pp. 1562-1572.
- LY6. Lyrantzis, A. S., Wissink, A. M., and Chronopoulos, A. T., "Efficient Iterative Methods for the Transonic Small Disturbance Equations," *AIAA Journal*, Vol. 30, No. 10, Oct. 1992, pp. 2556-2558.

LY7. Xue, Y., and Lyrintzis, A. S., "Transonic Blade-Vortex Interactions: Noise Reduction Techniques," *AIAA Journal of Aircraft*, Vol. 30, No. 3, May-June 1993, pp. 408-411.

LY8. Xue, Y., and Lyrintzis, A. S., "Rotating Kirchhoff Formulation for 3-D Transonic BVI Noise for a Hovering Rotor," *AIAA Journal*, Vol. 32, No. 7, July 1994, pp. 1350-1359.

LY9. Lyrintzis, A. S., Lee, J., and Xue, Y., "Mechanisms and Directivity of Unsteady Transonic Flow Noise," *ASME Journal of Fluids Engineering*, Vol. 116, No. 3, Sept. 1994, pp. 649-652.

LY10. Lyrintzis, A. S., "Review: The Use of Kirchhoff's Method in Computational Aeroacoustics," *ASME Journal of Fluids Engineering*, Vol. 116, No. 4, Dec. 1994, pp. 665-676.

LY11. Lyrintzis, A. S., and Mankbadi, R. R., "On the Prediction of the Far-Field Jet Noise Using Kirchhoff's Method," *AIAA Journal*, Vol. 34, No. 2, February 1996, pp. 413-416.

LY12. Lyrintzis, A. S., and Koutsavdis, E. K., "Rotorcraft Impulsive Noise Prediction Using a Rotating Kirchhoff Formulation," *AIAA Journal of Aircraft* Vol. 33, No. 6, Nov.-Dec. 1996.

LY13 Lyrintzis, A. S., Koutsavdis, E. K., and Strawn, R. C., "A Comparison of Computational Aeroacoustic Prediction Methods," *AHS Journal* (in press).

LY14. Lyrintzis, A. S., and Xue, Y. "Towards a Versatile Kirchhoff's Method Code," *AIAA Journal* (in press).

### **Conference Papers**

LY15. George, A. R., and Lyrintzis, A. S., "Mid-Field and Far-Field Calculations of Transonic Blade-Vortex Interactions," AIAA paper 86-1854, AIAA 10th Aeroacoustics Conference, Seattle, WA, July 9-11, 1986.

LY16. Lyrintzis, A. S., and George, A. R., "Transonic Blade-Vortex Interactions: The Far-Field," Proceedings of the American Helicopter Society National Specialists' Meeting on Aerodynamics and Aeroacoustics, Arlington, TX, Feb. 25-27, 1987.

LY17. Lyrintzis, A. S., and George, A. R., "Calculation of Far-Field Noise Using the Kirchhoff Method," AIAA Paper 87-2673, AIAA 11th Aeroacoustics Conference, Sunnyvale, CA, Oct. 19-21, 1987.

LY18. Lyrintzis, A. S., and George, A. R., "A Parametric Study of Transonic Blade-Vortex Interactions," Proceedings of NOISE-CON 88, Noise Control Design: Methods and Practice, edited by J. S. Bolton, Noise Control Foundation, New York, Purdue University, West Lafayette, IN, June 20-22, 1988, pp. 155-160.

LY19. Lyrintzis, A. S., and Xue, Y., "Noise Mechanisms of Transonic Blade-Vortex Interactions," Proceedings of the American Helicopter Society 46th Annual Forum, Washington, DC, May, 1990.

LY20. Xue, Y., and Lyrintzis, A. S., "Noise Reduction for Transonic Blade-Vortex Interactions," Proceedings of AHS/RAeS International Technical Specialists Meeting on Rotorcraft Acoustics and Rotor Fluid Dynamics, Philadelphia, PA, Oct. 1991.

LY21. Lyrintzis, A. S., Lee, J., and Xue, Y., "Mechanisms and Directivity of Unsteady Transonic Flow Noise," presented at the International Symposium on Flow Induced Vibration and Noise III, Vol. 3: Flow-Structure and Flow-Sound Interactions, eds Farabee, T. M., Paidoussis, M. P., ASME Winter Annual Meeting, Anaheim, CA, Nov. 1992, pp. 85-113.

LY22. Xue, Y., and Lyrintzis, A. S., "The Use of Rotating Kirchhoff Formulation for 3-D Transonic BVI Far-Field Noise," Proceedings of the American Helicopter Society 49th Annual Forum, St. Louis, MO, May 1993.

LY23. Lyrintzis, A. S., "The Use of Kirchhoff Method in Aeroacoustics," in Computational Aero- and Hydro-Acoustics, FED Vol. 147, eds: Mankbadi, R. R., Lyrintzis, A. S., Baysal, O., Povinelli, L. A., and Hussaini, M. Y., pp. 53-61; ASME Fluids Engineering Conference, Washington, DC, June 1993.

LY24. Lyrintzis, A. S., Xue, Y., and Kilaras, M. S., "The Use of a Rotating Kirchhoff Formulation for the Calculation of High-Speed Impulsive Noise," AIAA paper 94-0463, presented at the AIAA 32nd Aerospace Science Meeting, Reno, Nevada, Jan. 1994.

LY25. Lyrintzis, A. S., Kilaras, M., and Xue, Y., "Transonic 3-D BVI Noise Using a Rotating Kirchhoff Formulation for Advancing Rotors," Proceedings of the AHS 50th Annual Forum, Vol. I, Washington, DC, May 1994, pp. 115-127; also University of Minnesota Supercomputer Institute Research Report, UMSI 94/80, Minneapolis, MN, Apr. 1994.

LY26. Lyrintzis, A. S., "The Use of Kirchhoff's Method in Rotorcraft Aeroacoustics," Paper No. 34, presented at the 75th AGARD Fluid Dynamics Panel Meeting and Symposium on Aerodynamics and Aeroacoustics of Rotorcraft, Berlin, Germany, Oct. 1994; AGARD Conference Proceedings, No. 552, Aug. 1995, pp. 34-1 - 34-16.

LY27. Lyrintzis, A. S., "A Review of The Uses of Kirchhoff's Method in Computational Aeroacoustics," presented at the 1994 ASME International Mechanical Engineering Congress and Exposition, Chicago, IL, Nov. 1994; Acoustic Radiation and Wave Propagation, Ed. S. F. Wu, NCA Vol. 17, pp. 73-92.

LY28. Lyrintzis, A. S., and Mankbadi, R. R., "On the Prediction of the Far-Field Jet Noise Using Kirchhoff's Method," AIAA paper No. 95-0508 presented at the 33rd Aerospace Science Meeting, Reno, NV, Jan. 1995.

LY29. Strawn, R. C., Biswas, R., and Lyrintzis, A. S., "Computation of Helicopter Blade-Vortex Interaction Noise with Kirchhoff Methods" Proceedings of the 51st AHS Annual

Forum, Fort Worth, TX, May 1995, Vol. I, pp. 495-508; also *IMACS Journal of Computational Acoustics* (in press).

LY30. Lyrintzis, A., Koutsavdis, E., Berezin, C., Visintainer, J., and Pollack, M., "Kirchhoff Acoustic Methodology Validation and Implementation to TiltRotor Aeroacoustic Codes (TRAC)," Proceedings of the 2nd AHS International Aeromechanics Specialists' Conference, Vol. I, Bridgeport, CT, Oct. 1995.

LY31. Lyrintzis, A. S., Koutsavdis, E. K., and Strawn, R. C., "A Comparison of Computational Aeroacoustic Prediction Methods," Proceedings of the 2nd AHS International Aeromechanics Specialists' Conference, Vol. I, Bridgeport, CT, Oct. 1995, pp. 3-58 - 3-69.

LY32. Lyrintzis, A. S., "The Use of Kirchhoff's Method in Computational Aeroacoustics," presented at the Minisymposium on Issues and Methods in Computational Aeroacoustics, 1995 SIAM Annual Meeting, Charlotte, NC, Oct. 1995 [invited].

LY33. Wissink, A. M., Lyrintzis, A. S., Oliker, L., Biswas, R., and Strawn, R. C., "Efficient Helicopter Aerodynamic and Aeroacoustic Predictions on Parallel Computers," AIAA paper No. 96-0153, presented at the AIAA 34th Aerospace Science Meeting, Reno, NV, Jan. 1996.

LY34. Pilon, A., and Lyrintzis, A. S., "On the Development of a Modified Kirchhoff Method for Supersonic Jet Aeroacoustics," AIAA paper No. 96-1709, presented at the 2nd AIAA/CEAS Aeroacoustics Meeting, (17th AIAA Aeroacoustics Meeting) State College, PA, May 1996.

LY35. Lyrintzis, A. S., and Xue, Y. "Towards a Versatile Kirchhoff's Method Code," AIAA paper No. 96-1710, presented at the 2nd AIAA/CEAS Aeroacoustics Meeting, (17th AIAA Aeroacoustics Meeting) State College, PA, May 1996.

LY36. Brentner, K. S., Lyrintzis, A. S., and Koutsavdis, E. K., "A Comparison of Computational Aeroacoustic Prediction Methods for Transonic Rotor Noise," Proceedings of the 52nd AHS Annual Forum, Washington, DC, June 1996 Vol. 2, pp. 1103-1114.

## **PUBLICATIONS OF L. N. LONG AND CO-WORKERS**

### **Journal/Refereed Papers**

LO1. V. Ahuja and L. N. Long, "Electromagnetic Scattering using a Parallel Finite Volume Runge-Kutta Algorithm," submitted to *Journal of Computational Physics*, April, 1996.

LO2. Y. Ozyoruk and L. N. Long, "Computation of Sound Radiating from Engine Inlets," *AIAA Journal*, Vol. 34, No. 5, pp. 894-901, May, 1996.

LO3. Y. Ozyoruk and L. N. Long, "A New Efficient Algorithm for Computational Aeroacoustics on Parallel Processors, *Journal of Computational Physics*, Vol. 125, No. 1, pp. 135-149, April, 1996.

LO4. Y. Ozyoruk and L. Long, "Multigrid Acceleration of a High-Resolution Aeroacoustics Scheme," to appear *AIAA Journal*, 1997.

### **Conference Papers**

LO5. Y. Ozyoruk and L. N. Long, "Progress in Time-Domain Calculations of Ducted Fan Noise: Multigrid Acceleration of a High-Resolution CAA Scheme," AIAA Paper 96-1771, 17th AIAA Aeroacoustics Conference, State College, PA, May, 1996.

LO6. Y. Ozyoruk and L. N. Long, "A Time-Domain Implementation of Surface Acoustic Impedance Boundary Conditions With and Without Flow," AIAA Paper 96-1663, 17th AIAA Aeroacoustics Conference, State College, PA, May, 1996. (submitted to *Journal of Computational Acoustics*)

LO7. T. S. Chyczewski and L. N. Long, "Direct Simulations of Supersonic Jet Noise on Parallel Computers," AIAA-96-1730, 17th AIAA Aeroacoustics Conference, State College, PA, May, 1996. (submitted to *Journal of Computational Physics*)

LO8. P. J. Morris, L. N. Long, A. Bangalore, T. Chyczewski, D. Lockard, and Y. Ozyoruk, "Experiences in the Practical Application of Computational Aeroacoustics," ASME Fluids Conference, Invited Paper, April, 1996

LO9. V. Ahuja and L. N. Long, "A Message Passing Scheme for Computational Electromagnetics," ACES Conference, Monterey, CA, Mar., 1996.

LO10. L. N. Long, "Recent Developments in Computational Aeroacoustics," Invited Lecture. 130th Annual Meeting, St. Louis, The Journal of the Acoustical Society of America, Vol. 98, No. 5, Pt. 2, Nov., 1995.

LO11. Y. Ozyoruk and L. N. Long, "Computation of Sound Radiation from Engine Inlets," CEAS/AIAA Paper 95-063, First Joint CEAS/AIAA Aeroacoustics Conference, Munich, Germany, June, 1995.

LO12. V. Ahuja and L. N. Long, "A Finite Volume Algorithm for Maxwell's Equations on Massively Parallel Machines," AIAA-95-1967, AIAA Plasma Dynamics and Lasers Conference, San Diego, CA, June, 1995.

LO13. Y. Ozyoruk and L. N. Long, "A New Efficient Algorithm for Computational Aeroacoustics on Massively Parallel Computers," AIAA-95-1693, Proceedings of the AIAA CFD Conference, San Diego, CA, June, 1995.

LO14. V. Ahuja and L. N. Long, "A Message Passing Scheme for Computational Electromagnetics," ACES Conference, Monterey, CA, Mar. 20-26, 1995.

LO15. Y. Ozyoruk and L.N. Long, "A Navier-Stokes/Kirchhoff Method for Noise Radiation from Ducted Fans," AIAA Paper 94-0462, presented at the 32nd AIAA Aerospace Sciences Meeting, Reno, Nevada, Jan., 1994.

LO16. Y. Ozyoruk and L.N. Long, "A Hybrid Scheme for Noise Radiation from Ducted Fans," in Proceedings of Noise-Con '93, Williamsburg, VA, May, 1993.

#### **PUBLICATIONS OF R. C. STRAWN AND CO-WORKERS**

S1. Ahmad, J., Duque, E. P. N., and Strawn, R. C., "Computations of Rotorcraft Aeroacoustics with a Navier-Stokes/Kirchhoff Method," presented at the 22nd European Rotorcraft Forum, Brighton, UK, Sept. 16-19, 1996.

S2. Strawn, R. C., Olikier, L., and Biswas, R., "New Computational Methods for the Prediction and Analysis of Helicopter Acoustics," AIAA 96-1696, presented at the 2nd AIAA/CEAS Aeroacoustics Conference, State College, PA, May 6-8, 1996 (submitted to the *AIAA Journal of Aircraft*).

S3. Duque, E. P. N., Strawn, R. C., Ahmad, J., and Biswas, R., "An Overset Grid Navier-Stokes/Kirchhoff-Surface Method for Rotorcraft Aeroacoustic Predictions," AIAA-96-0152, presented at the 34th Aerospace Sciences Meeting, Reno, NV, Jan. 15-18, 1996.

S4. Wissink, A. M., Lyrintzis, A. S., Strawn, R. C., Olikier, L., and Biswas, R., "Efficient Helicopter Aerodynamic and Aeroacoustic Predictions on Parallel Computers," AIAA-96-0153, presented at the 34th Aerospace Sciences Meeting, Reno, NV, Jan. 15-18, 1996.

S5. Lyrintzis, A. S., Koutsavdis, E. K., and Strawn, R. C., "A Comparison of Computational Aeroacoustic Prediction Methods," presented at the 2nd International Aeromechanics Specialists' Conference, Bridgeport, CT, Oct. 11-13 1995, (submitted as a Technical Note to the *AHS Journal*).

S6. Strawn, R. C., Biswas, R., and Lyrintzis, A. S., "Helicopter Noise Predictions Using Kirchhoff Methods," presented at the 51st Annual Forum of the American Helicopter Society, May 9-11, 1995 (see also *Journal of Computational Acoustics*, Vol. 4, No. 3, Sept. 1996).

S7. Strawn, R. C., and Biswas, R., "Numerical Simulation of Helicopter Aerodynamics and Acoustics," presented at the 6th International Congress on Computational and Applied Mathematics, Brussels, Belgium, July 25-29, 1994. (see also *Journal of Computational and Applied Mathematics*, Vol. 66, No. 1-2, pp. 471-483 Jan. 1996)

S8. Strawn, R. C., and Biswas, R., "Computation of Helicopter Rotor Acoustics in Forward Flight," presented at the 19th Army Science Conference, Orlando, FL, June 11-14, 1994. (see also *Journal of the American Helicopter Society*, Vol. 4, No. 3, July, 1995, pp. 66-72.)



S9. Strawn, R. C., Biswas, R., and Garceau, M., "Unstructured Adaptive Mesh Computations of Rotorcraft High-Speed Impulsive Noise," AIAA-93-4359, presented at the AIAA 15th Aeroacoustics Conference, Long Beach, CA, Oct. 1993. (see also *Journal of Aircraft*, Vol. 32, No. 4, July-August, 1995, pp. 754-760)

# **APPENDIX**

## **Workshop Viewgraphs**

# **The Kirchhoff Formulas for Moving Surfaces in Aeroacoustics—The Subsonic and Supersonic Cases**

by  
**F. Farassat**

**Aeroacoustics Branch  
Fluid Mechanics and Acoustics Division  
Langley Research Center**

**Based on Lectures Delivered in Workshop on Kirchhoff Formulas for Moving Surfaces, NASA Langley Research Center, February 15, 1995**

**F. Farassat, Aeroacoustics Branch  
Fluid Mechanics and Acoustics Division  
NASA Langley Research Center  
Hampton, Virginia**

# Available Methods of Noise Prediction in Aeroacoustics

Today we have three methods available. These are:

1. **The Acoustic Analogy** introduced into aeroacoustics by Lighthill (1952). Applications to rotating blades are based on Ffowcs Williams-Hawkins (FW-H) equation (1969). It is the most developed method and is widely in use in the aircraft industry.
2. **The Kirchhoff Formula** based method. Originally suggested by Hawkings in aeroacoustics (1979), this method is currently under development. Availability of high resolution aerodynamics and powerful computers may make this approach very popular in the future.
3. **The CFD Based CAA** (Computational Aeroacoustics). This method is under development and is the least mature of the three methods. It may be appropriate for some problems. Computational Techniques developed here will also help the above two methods.

# Classical Kirchhoff Formula (1882)

$$4\pi\phi(\hat{x}, t) = \int_{f=0} \frac{[-\phi_n + c^{-1}\dot{\phi}\cos\theta]_{\text{ret}}}{r} dS + \int_{f=0} \frac{[\phi\cos\theta]_{\text{ret}}}{r^2} dS$$

ret: retarded time,  $\phi_n = \frac{\partial\phi}{\partial n}$ ,  $r = |\hat{x} - \hat{y}|$

- Gives  $\phi$  in terms of values of  $\phi$ ,  $\dot{\phi}$  and  $\phi_n$  on the Kirchhoff surface. It is Green's Identity for the wave equation. Compare with the following identity for Laplace equation:

$$4\pi\phi(\hat{x}) = - \int_{f=0} \frac{\phi_n}{r} dS + \int_{f=0} \frac{\phi\cos\theta}{r^2} dS$$

- We derive both above results by the same method using generalized function theory.

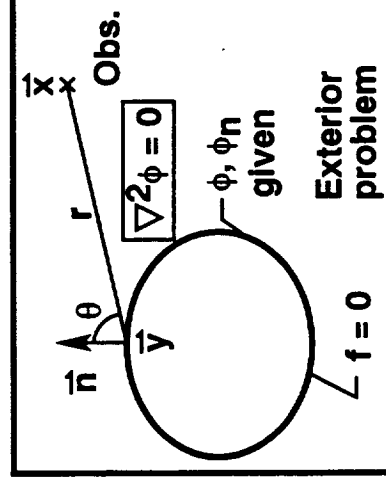
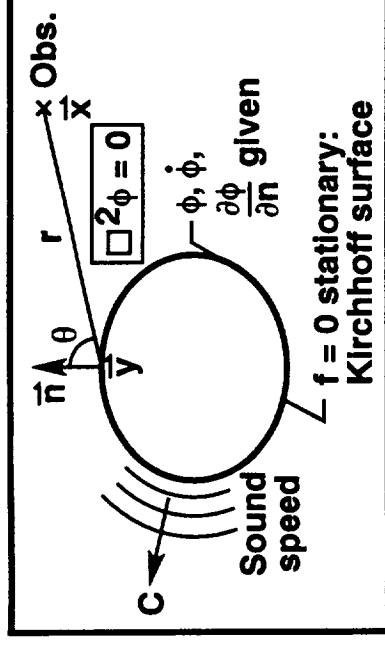

## Classical Kirchhoff Formula (Cont'd)

- Derived in 1882 by G. Kirchhoff
- See Classical Derivation by D. S. Jones “*The Theory of Electromagnetism*,” Pergamon Press, 1964, sec. 1.17, p. 40. Also see M. Born and E. Wolf “*Principles of Optics*,” Pergamon Press, 1970, sec. 8.3, p. 375 (good applications here).
- Applications in optics, electromagnetism and acoustics are very extensive. Until recently the classical Kirchhoff formula has been used either as approximation or for qualitative understanding of fields governed by the wave equation. The availability of high speed digital computers has changed this picture. Simulation of the wave field is possible and rewarding! Extension to moving surfaces has opened new applications.
- See also A. D. Pierce “*Acoustics*,” Acoust. Soc. Am. 1989, p. 180.

# Why are Kirchhoff Formulas Important in Acoustics

- Accurate prediction of the noise of helicopter rotors, propellers and ducted fans, particularly at design stage, is needed to reduce the passenger and public annoyance and to meet noise standards.
- Low noise aircraft and propulsion systems sell better in the international market. Therefore, noise prediction tools to meet U.S. aircraft and engine industry needs must be developed.
- Kirchhoff formulas for moving surfaces coupled to advanced CFD codes supply an efficient and powerful tool for noise prediction. See box above.

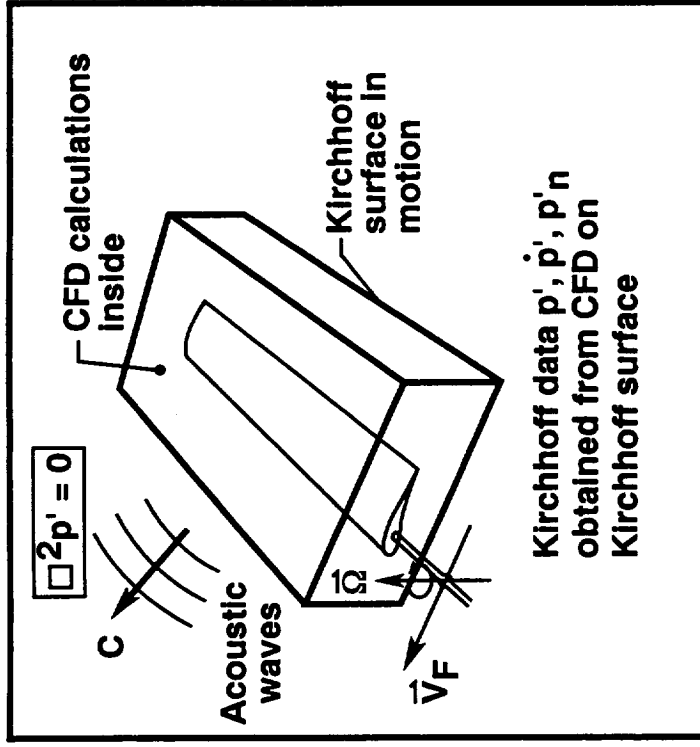

## What is this Workshop About?

- Our *primary purpose* in this workshop is the derivation of two Kirchhoff formulas for subsonic and supersonic surfaces.
- When working with inhomogeneous wave equation for moving sources using classical methods, we notice that the algebraic manipulations quickly become complicated. We lose track of cancellations and simplifications. We need special tools from mathematics which give us simple and direct method of derivation.
- The *secondary purpose* of this workshop is to give all the necessary tools from generalized function (GF) theory, P.D.E.'s and differential geometry.



## Method of Deriving Kirchhoff Formulas

- We reduce the derivation of the three Kirchhoff formulas (stationary, subsonic and supersonically moving surface) here to the solution of wave equation  $\nabla^2 \phi = Q$  where  $Q$  is a generalized function (such as  $q\delta(\mathbf{f})$ ). This is the most direct approach to deriving Kirchhoff formulas. One must, therefore, learn some generalized function theory. The source distributions are on moving surfaces and invariably the geometry of these surfaces enters the derivation. Without the knowledge of differential geometry of surfaces, we cannot identify surface curvature terms and other geometric quantities resulting in a large number of meaningless terms in the Kirchhoff formula. A formula in this form is not very useful in applications.
- **Note:** In applications, the Kirchhoff surface is divided into panels and the contributions of individual panels are added together. The stationary and subsonic Kirchhoff formulas remain unchanged for open or closed surfaces. We derive the supersonic formula for an open surface only. The extension to a closed surface is trivial.

# **Elements of Generalized Function Theory**

**F. Farassat, Aeroacoustics Branch  
Fluid Mechanics and Acoustics Division  
NASA Langley Research Center  
Hampton, Virginia**

**24 of 111, September 1996**

# Models of Functions

**Old (Conventional) Model:** We think of a function as a table of ordered pairs  $(x, f(x))$  where for each  $x$ ,  $f(x)$  is unique. This table can be graphed as shown and usually has an uncountable number of ordered pairs.

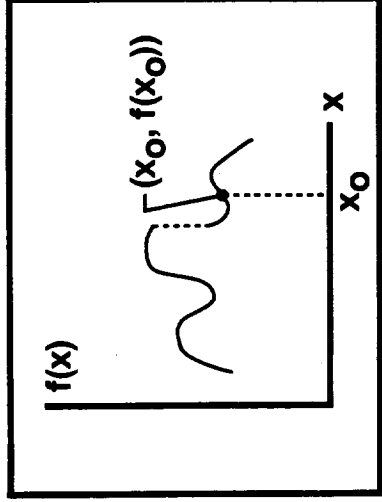

**New Model:** We think of a function  $f$  by its *action (functional values)* on a given space of ordinary functions called *test function space*. This action for ordinary functions is defined by

$$F[\phi] = \int f(x)\phi(x)dx.$$

The function  $f$  is now

defined (identified, thought of) by the new table  $\{F[\phi], \phi \text{ is in the test function space}\}$ . This view of ordinary functions now allows us to incorporate  $\delta(x)$  into mathematics rigorously.

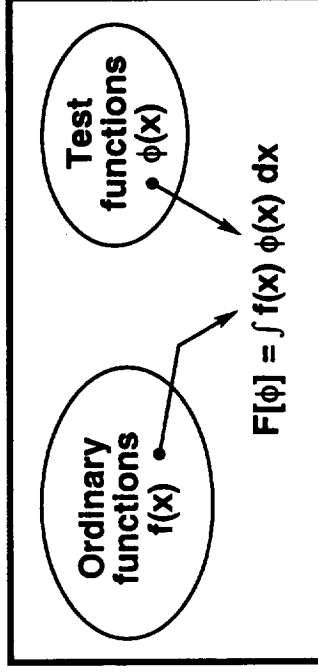

# A Familiar Example of Thinking About Functions by New Model

Consider space of periodic functions with period  $2\pi$ . Take the *test function space* to be the space formed by functions  $\phi_n = \exp(inx)$ ,  $n = 0, \pm 1, \pm 2, \dots$ . Let  $f$  be periodic with period  $2\pi$ . The Fourier coefficients of  $f$  can be viewed as functionals on test function space by the relation

$$F[\phi_n] = \frac{1}{2\pi} \int_0^{2\pi} f(x) e^{inx} dx$$

From the theory of Fourier analysis, we know that the following table of Fourier coefficients (i.e., *functional values* of  $f$  on test function space) contains the same information as  $f(x)$ :

$$\{F[\phi_n], n = 0, \pm 1, \pm 2, \dots\}$$

Note that if  $f(x) \neq g(x)$ , where  $g(x)$  is another periodic function with period  $2\pi$ , then

$$F[\phi_n] \neq G[\phi_n] = \frac{1}{2\pi} \int_0^{2\pi} g(x) e^{inx} dx$$

for some  $n$ , i.e., the new table uniquely defines functions.

# Elementary Generalized Function Theory

The main reason to develop the generalized function theory is to include mathematical objects such as the Dirac delta “function”  $\delta(x)$ . This function has the *sifting property*

$$\int_{-a}^a \phi(x)\delta(x)dx = \phi(0)$$

To include these objects in mathematics, we need to change our thinking about functions. The reason we must change our thinking about functions is that no ordinary function can have the sifting property. We must therefore enlarge the space of functions by a process familiar in mathematics: define (look at, view) functions in a way which includes all ordinary functions as well as objects like the Dirac delta function. This is a *change of paradigm* familiar to us when we learned fractions, negative numbers and complex numbers.

## Definition of Generalized Functions

- A *functional* on a space of functions  $\Omega$  is a mapping (a rule) of  $\Omega$  into scalars (real or complex numbers).

**Examples:** Take  $\Omega$  as space of differentiable functions. The following are functionals on  $\Omega$ ,  $\phi \in \Omega$

i)  $F[\phi] = \phi'(0) + 2\phi(1)$

ii)  $F[\phi] = \int_0^1 \phi^2(x) dx$

iii)  $F[\phi] = \sin[\phi(0)]$

iv)  $F[\phi] = 2\phi(1) + \int_{-1}^1 \phi(x) dx$

- In the theory, the functionals act on various test function spaces depending on the problem. We define generalized functions on the following test function space:

**Space D of Test Functions:** infinitely differentiable functions with bounded support.

- The *support* of a function  $\phi$  is the closure of the set on which  $\phi \neq 0$ . We use  $\text{supp } \phi$  for support of  $\phi$ .

# Definition of Generalized Functions (Cont'd)

- Example of functions in D:

$$i) \text{ Let } \phi(x; a) = \begin{cases} \exp\left[\frac{a^2}{x^2 - a^2}\right] & |x| < a \\ 0 & |x| \geq a \end{cases}$$

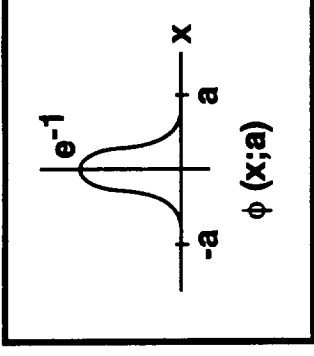

$$\Rightarrow \phi(x; a) \in D$$

- ii) Let  $g(x)$  be any continuous function, then

$$\psi(x) = \int_b^c g(y)\phi(x - y; a)dy, \text{ where } [b, c] \text{ is a finite interval, belongs}$$

to D. We can show that  $\text{supp } \psi(x) = [b - a, c + a]$ .

- Example (ii), above, shows that space D is populated with an uncountably infinite number of functions. This means that the table of functional values on D in our new model of functions has an uncountably infinite number of members.

## Definition of Generalized Functions (Cont'd)

- By an *ordinary function* we mean a locally (Lebesgue) integrable function.
- **A Reminder:** In our new model of thinking about functions, we identify an ordinary function  $f(x)$  by table  $\{F[\phi] = \int f\phi dx, \phi \in D\}$ .

The functional  $F[\phi] = \int f\phi dx$  is *linear* and *continuous*. We define linearity and continuity below.

- A functional on  $D$  is *linear* if  $F[\alpha\phi_1 + \beta\phi_2] = \alpha F[\phi_1] + \beta F[\phi_2]$  for all  $\phi_1$  and  $\phi_2$  in  $D$

- **Examples:**  $\phi \in D$

i)  $F[\phi] = \phi(0)$  is linear

ii)  $F[\phi] = 2\phi'(1) - \int f\phi dx$ ,  $f$  an ordinary function, is linear

iii)  $F[\phi] = \phi^2(0)$  is nonlinear



## Definition of Generalized Functions (Cont'd)

- A sequence of functions  $\{\phi_n\}$  in  $D$  converges to zero in  $D$ , written as  $\phi_n \xrightarrow{D} 0$ , if  $\phi_n$  and all its derivatives converge uniformly to zero and  $\text{supp } \phi_n \subset I$  for all  $n$  where  $I$  is a fixed bounded interval.
- A functional on  $D$  is *continuous* if  $F[\phi_n] \rightarrow 0$  if  $\phi_n \xrightarrow{D} 0$ .
- This definition seems very strange but gives generalized functions some of their nicest properties.

### Examples:

- Let  $\phi_n = \frac{1}{n}\phi(x; a)$ , where  $\phi(x; a)$  was defined earlier,  $\Rightarrow \phi_n \xrightarrow{D} 0$
- $\phi_n = \frac{1}{n}\phi\left(x; \frac{a}{n}\right) \Rightarrow \phi_n \not\xrightarrow{D} 0$  because  $\text{supp } \phi_n = [-na, na]$  becomes unbounded as  $n \rightarrow \infty$
- Linear functionals in the examples on previous vugraph are continuous.
- $\delta[\phi] = \phi(0)$ ,  $\phi \in D$ , is continuous (It is also linear.)

## Definition of Generalized Functions (Cont'd)

- Any ordinary function  $f$  defines a continuous linear functional on  $D$  by the relation  $F[\phi] = \int f\phi dx$ ,  $\phi \in D$ . But ordinary functions do not exhaust all continuous linear functionals on  $D$ .
- **Definition of Generalized Functions:** A continuous linear functional on space  $D$  defines a *generalized function*. The space of all generalized functions is denoted  $D'$

**Examples:**  $\phi \in D$

- $\delta[\phi] = \phi(0)$  defines a generalized function. We can show that there is no ordinary function  $f(x)$  such that  $\int f(x)\phi(x)dx = \phi(0)$ . This means that  $D'$  is larger than the space of ordinary functions.
- $G[\phi] = 2\phi'(1) + 3\int f\phi dx$ ,  $f$  ordinary function, defines a generalized function

# Definition of Generalized Functions (Cont'd)

• It is inconvenient to work with functional notation in mathematical manipulations. For this reason, we introduce the notation of symbolic functions for those generalized functions which are not ordinary functions. Ordinary functions are called *regular* generalized functions. Other generalized functions are called *singular* generalized functions. For singular generalized function  $F[\phi]$ , we define the symbolic function  $f(x)$  so that

$\int f(x)\phi(x)dx \equiv F[\phi]$  for  $\phi \in D$ . It is important to recognize that the integral on the left is just a symbol standing for  $F[\phi]$  and one should not treat it as an ordinary integral.

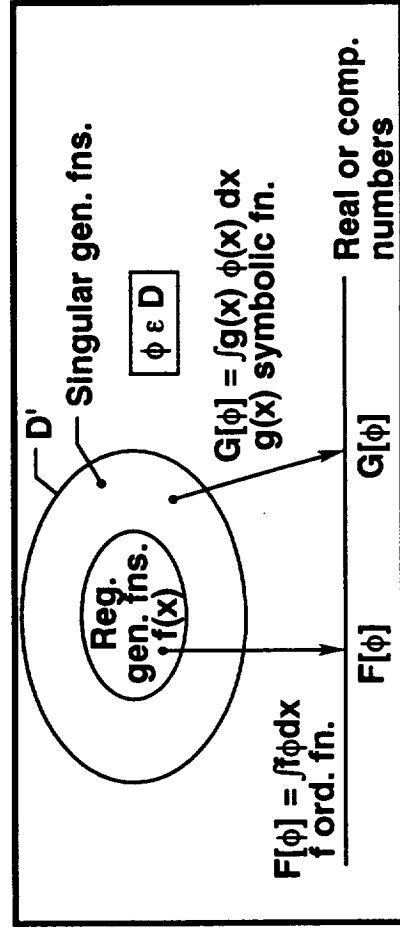

This is the picture of the space of generalized functions  $D'$  we should have in mind.

## Some Operations on Generalized Functions

**Note:** All test functions are in space  $D$  ( $C^\infty$  fns with compact supp.)

i) *Equality* of two generalized functions on an open interval  $I$ :  $F[\phi] = G[\phi]$  on  $I$  if for all  $\phi$  in  $D$  such that  $\text{supp } \phi \subset I$ , we have  $F[\phi] = G[\phi]$  (symbolically  $f(x) = g(x)$ ).

**Example:**  $\delta(x) = 0$  on  $(0, \infty)$  since  $\delta[\phi] = \phi(0) = 0$  for all  $\phi$  such that  $\text{supp } \phi \subset (0, \infty)$ . This means that a singular generalized function can be equal to an ordinary function (here  $f = 0$ ) on an open interval.

ii) *Multiplication* of a generalized functions  $F[\phi]$  with a  $C^\infty$  function  $a(x)$ :  
 $aF[\phi] = F[a\phi]$  (left side is defined by right side).

**Example:**  $a\delta[\phi] = \delta[a\phi] = a(0)\phi(0)$  or symbolically  
 $a(x)\delta(x) = a(0)\delta(x)$ , an important result!

**Note:** Multiplication of two singular generalized functions or a regular and a singular generalized functions *may* not be defined.

## Some Operations on Generalized Functions (Cont'd)

iii) *Addition* of generalized functions:  $(F + G)[\phi] = F[\phi] + G[\phi]$  or symbolically  $(f + g)(x) = f(x) + g(x)$

iv) *Shift Operation*:  $E_h F[\phi] = F[E_{-h}\phi]$  where  $E_{-h}\phi = \phi(x - h)$

**Example**:  $E_h \delta[\phi] = \delta[E_{-h}\phi] = \phi(-h)$  or symbolically

$$\int E_h \delta(x)\phi(x)dx = \int \delta(x + h)\phi(x)dx = \phi(-h)$$

**Note**: Generalized functions are not defined at a point but on open intervals. In practice, this does not cause problems.

- We can define other operations such a *dilation*:

$$\int \delta(\alpha x)\phi(x)dx = \frac{1}{|\alpha|}\phi(0) \Rightarrow \delta(\alpha x) = \frac{1}{|\alpha|}\delta(x), \text{ and } \textit{Fourier transform (F.T.)}$$

$\hat{F}[\phi] = F[\hat{\phi}]$ ,  $\hat{\phi} = \text{F.T.}(\phi)$  where  $\phi$  now belongs to space of rapidly decreasing test functions  $S$ . For our purpose, the most important operation on generalized functions is *differentiation*.

## Differentiation of Generalized Functions

All test functions are in  $D$ .

- $f(x)$  ordinary function, differentiable,  $F[\phi] = \int f\phi dx$ , we must identify  $F'[\phi]$  with  $\int f'\phi dx$ . But  $F'[\phi] \equiv \int f'\phi dx = -\int f\phi' dx = -F[\phi']$  since  $\phi' \in D$ .

Therefore, we use the relation:

$$F'[\phi] = -F[\phi']$$

as the definition of derivative of any generalized function  $F[\phi]$ . Similarly

$F^{(n)}[\phi] = (-1)^n F[\phi^{(n)}]$ , i.e., generalized functions have derivatives of all orders.

**Examples:**

i)  $\delta'[\phi] = -\delta[\phi'] = -\phi'(0)$  or  $\int \delta'(x)\phi(x)dx = -\phi'(0)$

ii)  $\delta''[\phi] = (-1)^2 \delta[\phi''] = \phi''(0)$  or  $\int \delta''(x)\phi(x)dx = \phi''(0)$

**Note:** If an ordinary function is differentiable on real line, then  $f'_{\text{gen.}} = f'$ . However, generalized derivative of an ordinary function *can* be a singular generalized function.

# Differentiation of Generalized Functions (Cont'd)

**Notation:** For ordinary (regular G.F.'s) functions, we use  $\bar{f}'(x)$  or  $\frac{df}{dx}$  for  $f'$  gen. to distinguish generalized from ordinary derivative.

**Example:** Generalized derivative of an ordinary function with a jump.

$$F[\phi] = \int f\phi dx, \phi \in D$$

$$F'[\phi] = -\int f \phi' dx$$

$$= - \left( \int_{-\infty}^{x_0^-} + \int_{x_0^+}^{\infty} \right) f \phi' dx = \int f' \phi dx + \Delta f \phi(x_0)$$

or symbolically

$$\bar{f}'(x) = f'(x) + \Delta f \delta(x - x_0)$$

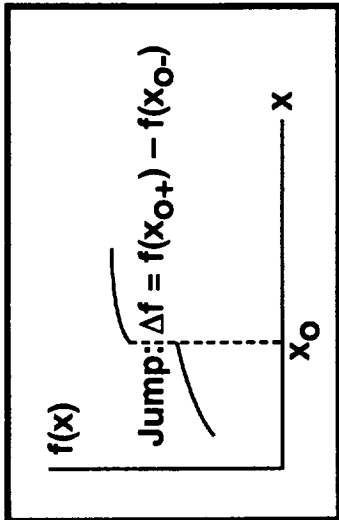

## Differentiation of Generalized Functions (Cont'd)

**Example:** Generalized derivative of Heaviside function

$$h(x) = \begin{cases} 1 & x > 0 \\ 0 & x < 0 \end{cases}.$$

$$\bar{h}'(x) = \delta(x) \text{ since } h'(x) = 0 \text{ on } (0, \infty) \cup (-\infty, 0).$$

- **Note:** Even at this level of exposition, we can do a lot we could not do by using ordinary functions. We can discuss Green's function of an O.D.E., for example.



# Some Important Results of Generalized Function Theory

- **Structure Theorem of  $D'$ :** Generalized functions in  $D'$  are generalized derivatives of finite order of continuous functions.
- **Sequences of Generalized Functions:** A sequence  $\{F_n[\phi]\}$  of generalized functions is *convergent* if for all  $\phi \in D$ , the sequence of numbers  $\{F_n[\phi]\}$  is convergent.
- **Theorem:** The space  $D'$  is complete.

This theorem implies that a convergent sequence of generalized functions gives (i.e., converges to) a generalized function. This theorem is the basis of the sequential approach to generalized function theory (see books by Lighthill and Jones).

# Some Important Results of Generalized Function Theory (Cont'd)

- **Exchange of Limit Processes:** We can exchange limit processes when we are dealing with generalized functions. This result is very important in applications.

**Examples:**

$$\frac{\bar{\partial}^2 f}{\partial x_i \partial x_j} = \frac{\bar{\partial}^2 f}{\partial x_j \partial x_i}; \quad \sum_i \int_{\Omega} \dots = \int_{\Omega} \sum_i \dots; \quad \frac{\bar{\partial}}{\partial x_i} \int_{\Omega} \dots = \int_{\Omega} \frac{\bar{\partial}}{\partial x_i} \dots;$$

$$\lim_{n \rightarrow \infty} \sum_m \dots = \sum_m \lim_{n \rightarrow \infty} \dots; \quad \frac{\bar{d}}{dx} \lim_{m \rightarrow \infty} \dots = \lim_{m \rightarrow \infty} \frac{\bar{d}}{dx} \dots$$

**Note:** In the rule of exchanging the order of differentiation and integration, we assume that  $\Omega$  is independent of  $\hat{x}$ .

# Green's Function of a 2nd Order Linear O.D.E.

$$\text{Given } \left\{ \begin{array}{l} lu = f(x) \quad x \in [0, 1] \quad \text{Linear 2nd order O.D.E.} \\ BC_1[u] = a_1 u(0) + b_1 u'(0) + c_1 u(1) + d_1 u'(1) = 0 \\ BC_2[u] = a_2 u(0) + b_2 u'(0) + c_2 u(1) + d_2 u'(1) = 0 \end{array} \right\} \text{Linear Homogeneous BCs}$$

Assume there is a function  $g(x, y)$  (*Green's function*) such that

$$u(x) = \int_0^1 f(y)g(x, y)dy \tag{1}$$

We are interested in solutions where  $u \in C^1$  and  $u$  is twice differentiable so that  $\bar{u}'' = u''$  and  $\bar{u}' = u'$  and, therefore,  $\bar{lu} = lu$ . Here  $\bar{lu}$  stands for the differential equation where ordinary derivatives are replaced by generalized derivatives. From eq. (1), we have

$$\begin{aligned} \bar{lu}(x) &= \bar{l}_x \int_0^1 f(y)g(x, y)dy = \int_0^1 f(y)\bar{l}_x g(x, y)dy \text{ (exchange of limit process)} \\ &= f(x) \text{ (by the O.D.E.)} \end{aligned}$$

# Green's Function of a 2nd Order Linear O.D.E. (Cont'd)

Therefore

$$\bar{l}_x g(x, y) = \delta(x - y)$$

We will interpret this equation later. Note that since the boundary conditions are

$$\text{linear: } BC_1[u] = BC_{1,x} \int_0^1 f(y) g(x, y) dy$$

$$= \int_0^1 f(y) BC_{1,x} [g(x, y)] dy = 0$$

A similar result also holds for  $BC_2[u]$ .

$$\therefore BC_{1,x} [g(x, y)] = 0, \quad BC_{2,x} [g(x, y)] = 0,$$

i.e.,  $g(x, y)$  in variable  $x$  satisfies both  $BC$ 's.

# Green's Function of a 2nd Order Linear O.D.E. (Cont'd)

- What is the interpretation of  $\int_x^1 g(x, y) = \delta(x - y)$ ?

Let  $l = A(x) \frac{d^2}{dx^2} + B(x) \frac{d}{dx} + C(x)$ , then  $g(x, y)$  and  $\frac{\partial g}{\partial x}(x, y)$  must have some

kind of discontinuity at  $x = y$ .

$$\text{Let } g(x, y) = \begin{cases} g_1(x, y) & x < y \\ g_2(x, y) & x > y \end{cases}$$

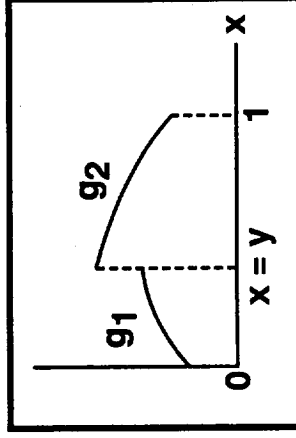

## Green's Function of a 2nd Order Linear O.D.E. (Cont'd)

Then 
$$\frac{\partial g}{\partial x} = \frac{\partial g}{\partial x} + \Delta g \delta(x-y)$$

$$\frac{\partial^2 g}{\partial x^2} = \frac{\partial^2 g}{\partial x^2} + \Delta \left( \frac{\partial g}{\partial x} \right) \delta(x-y) + \Delta g \delta'(x-y)$$

$$\begin{aligned} \bar{l}_x g(x, y) &= l_x g(x, y) + \left[ A(y) \Delta \left( \frac{\partial g}{\partial x} \right) + B(y) \Delta g \right] \delta(x-y) + A(x) \Delta g \delta'(x-y) \\ &= \delta(x-y) \text{ (by the result of previous page)} \end{aligned}$$

$$\therefore \Delta g = 0 \text{ at } x = y \text{ and } \Delta \left( \frac{\partial g}{\partial x} \right) = \frac{1}{A(y)} \text{ at } x = y$$

This means  $l_x g_1(x, y) = l_x g_2(x, y) = 0$ ,  $g(x, y)$  is continuous at  $x = y$  and

$\frac{\partial g}{\partial x}$  has a jump equal to  $1/A(y)$  at  $x = y$ .

# Generalized Functions in Multidimensions

- **Space D in Multidimensions:** This space is formed by  $c^\infty$  functions with bounded support. Define

$$\phi(\hat{x}; a) = \begin{cases} \exp\left[\frac{a^2}{a^2 - |\hat{x}|^2}\right] & |\hat{x}| < a, \\ 0 & |\hat{x}| \geq a \end{cases} \quad |\hat{x}| = \left[ \sum_{i=1}^n x_i^2 \right]^{1/2}$$

This belongs to D in  $n$  dimensions. Given any continuous function  $g(\hat{x})$  and any bounded region  $\Omega$

$$\psi(\hat{x}) = \int_{\Omega} g(\hat{y}) \phi(\hat{x} - \hat{y}; a) d\hat{y} \Rightarrow \psi(\hat{x}) \in D$$

- As in the case of space D in one dimension, the space D in  $n$  dimension is populated by an uncountably infinite number of functions.

## Generalized Functions in Multidimensions (Cont'd)

- *Generalized functions* in  $n$  dimensions are continuous linear functionals on  $n$  dimensional test function space  $D$ .

- **Examples:**

- i)  $\int \delta(\hat{x})\phi(\hat{x})d\hat{x} = \phi(0)$

- ii)  $\int \left[ \frac{\partial}{\partial x_i} \delta(\hat{x}) \right] \phi(\hat{x})d\hat{x} = - \frac{\partial \phi}{\partial x_i}(0)$

- From our point of view, the most important generalized functions are delta functions whose supports are on open or closed surfaces, e.g.,  $\delta(f)$ . We need to interpret integrals of the form

$$I_1 = \int \delta(f)\phi(\hat{x})d\hat{x} \quad \text{and} \quad I_2 = \int \delta'(f)\phi(\hat{x})d\hat{x}.$$



## How Does $\delta(f)$ Appear in Applications?

Assume  $g(\hat{x})$  is discontinuous across the surface  $f(\hat{x}) = 0$  with the jump

$$\Delta g = g(f = 0+) - g(f = 0-)$$

Set up coordinate system  $(u^1, u^2)$  on  $f = 0$  and extend these coordinates to the vicinity of  $f = 0$  along local normals. Take  $u^3 = f$  as third local variable. Then (assuming  $g$  is continuous in  $u^1, u^2$ )

$$\bar{\frac{\partial g}{\partial u^i}} = \frac{\partial g}{\partial u^i} \quad i = 1, 2 \quad \text{and}$$

$$\bar{\frac{\partial g}{\partial x_j}} = \frac{\partial g}{\partial u^i} \frac{\partial u^i}{\partial x_j} = \frac{\partial g}{\partial u^3} \frac{\partial u^3}{\partial x_j} + \Delta g \frac{\partial u^3}{\partial x_j} = \frac{\partial g}{\partial x_j} + \Delta g \frac{\partial u^3}{\partial x_j}$$

Since  $u^3 = f$ , we have  $\bar{\nabla} g = \nabla g + \Delta g \nabla f \delta(f)$ .

Similarly

$$\begin{aligned} \bar{\nabla} \cdot \hat{g} &= \nabla \cdot \hat{g} + \Delta \hat{g} \cdot \nabla f \delta(f) \\ \bar{\nabla} \times \hat{g} &= \nabla \times \hat{g} + \Delta \hat{g} \times \nabla f \delta(f) \end{aligned}$$

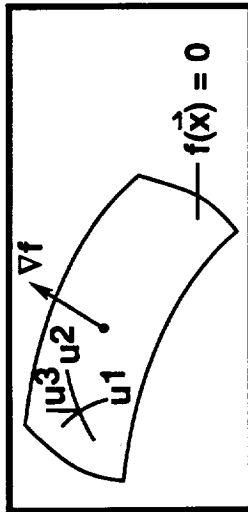

## How Does $\delta(f)$ Appear in Applications? (Cont'd)

- In our work the discontinuities in functions are either real (e.g., shock waves) or artificial (e.g., across blade surface in derivation of FW-H eq.).
- **Example:** *Shock surface sources* in Lighthill jet noise theory. Let the shock surfaces be defined by  $f(\hat{x}, t) = 0$ . We can show that Lighthill's equation is valid in presence of shocks if we interpret the derivatives of the source term as generalized derivatives:

$$\begin{aligned} \square^2 p' &= \frac{\partial^2 T_{ij}}{\partial x_i \partial x_j} \\ &= \bar{\partial} \left[ \frac{\partial T_{ij}}{\partial x_j} + \Delta T_{ij} \frac{\partial f}{\partial x_j} \delta(f) \right] \\ &= \underbrace{\frac{\partial^2 T_{ij}}{\partial x_i \partial x_j} + \Delta \left( \frac{\partial T_{ij}}{\partial x_j} \right) \frac{\partial f}{\partial x_i} \delta(f)}_{\text{Turbulence Source}} + \underbrace{\frac{\partial}{\partial x_i} \left[ \Delta T_{ij} \frac{\partial f}{\partial x_j} \delta(f) \right]}_{\text{Shock Surface Sources}} \end{aligned}$$

# **Elements of Differential Geometry**

F. Farassat, Aeroacoustics Branch  
Fluid Mechanics and Acoustics Division  
NASA Langley Research Center  
Hampton, Virginia

## Some Results From Differential Geometry

- Introduce the local surface variables  $(u^1, u^2)$  on a surface. Define local tangent vectors  $\hat{r}_1 = \partial \hat{r} / \partial u^1$  and  $\hat{r}_2 = \partial \hat{r} / \partial u^2$ . In general, these are not of unit length. Let  $g_{ij} = \hat{r}_i \cdot \hat{r}_j$ , the first fundamental form is

$$dl^2 = g_{11}(du^1)^2 + 2g_{12}du^1 du^2 + g_{22}(du^2)^2, \quad g_{12} = g_{21}.$$

This gives the element of length of a curve on the surface. In this relation  $g_{ij}$ 's are known as coefficients of the first fundamental form. We define  $g_{(2)}$  as the determinant of

$$g_{(2)} = \begin{vmatrix} g_{11} & g_{12} \\ g_{21} & g_{22} \end{vmatrix} = g_{11}g_{22} - g_{12}^2.$$

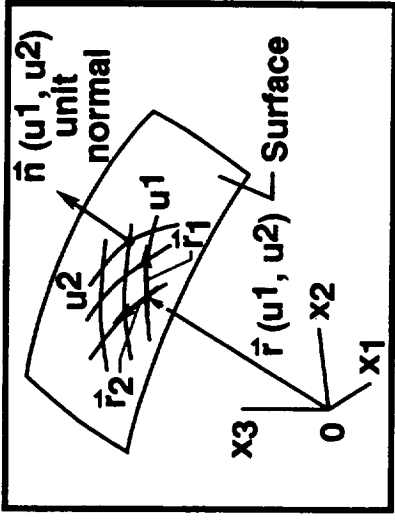

## Some Results From Differential Geometry (Cont'd)

- We can show that *the element of surface area*  $dS$  is  $dS = |\hat{r}_1 \times \hat{r}_2| du^1 du^2$ .

Since  $g(2) = |\hat{r}_1 \times \hat{r}_2|^2$ , we have  $dS = \sqrt{g(2)} du^1 du^2$ .

**Note:** We use summation convention on repeated index below.

- Define  $g^{ij}$  as elements of the inverse of the matrix  $G = \begin{bmatrix} g_{11} & g_{12} \\ g_{21} & g_{22} \end{bmatrix}$ ,

$$\text{i.e., } G^{-1} = \begin{bmatrix} g^{11} & g^{12} \\ g^{21} & g^{22} \end{bmatrix} \Rightarrow g^{11} = \frac{g_{22}}{g(2)}, g^{22} = \frac{g_{11}}{g(2)}, g^{12} = g^{21} = -\frac{g_{12}}{g(2)}$$

We have  $g^{ij} g_{jk} = \delta_k^i$  where  $\delta_k^i$  is the Kronecker delta.

## Some Results From Differential Geometry (Cont'd)

- Define  $b_{ij} = \hat{r}_{ij} \cdot \hat{n}$  where  $\hat{r}_{ij} = \partial^2 \hat{r} / \partial u^i \partial u^j$ . The second fundamental form is  $\Pi = b_{11} (du^1)^2 + 2b_{12} du^1 du^2 + b_{22} (du^2)^2$ . Note that  $b_{12} = b_{21}$  and  $\hat{n}$  is the local unit normal. In this relation  $b_{ij}$ 's are known as coefficients of 2nd fundamental form.

$$b = \begin{vmatrix} b_{11} & b_{12} \\ b_{21} & b_{22} \end{vmatrix} = b_{11} b_{22} - b_{12}^2$$

The quantity  $b$  is the determinant of coefficient of 2nd fundamental form.

# Some Results From Differential Geometry (Cont'd)

- What is the geometrical meaning of  $\Pi$ ?

$$d = \hat{n} \cdot d\hat{r}$$

$$= \hat{n} \cdot \left[ \hat{r}_1 du^1 + \hat{r}_2 du^2 + \frac{1}{2} [ \hat{r}_{11} (du^1)^2 + 2\hat{r}_{12} du^1 du^2 + \hat{r}_{22} (du^2)^2 ] + \dots \right]$$

$$= \frac{1}{2} \Pi + O(du^i)^3 \quad \therefore \Pi \approx 2d$$

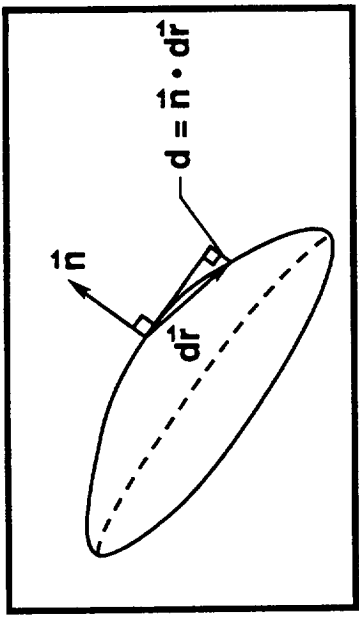

- Another relation for  $b_{ij}$ :  $b_{ij} = -\hat{r}_i \cdot \hat{n}_j$ ,  $\hat{n}_j = \partial \hat{n} / \partial u^j$

- Weingarten Formula:  $\hat{n}_i = -b_i^j \cdot \hat{r}_j$  where  $b_i^j = g^{jk} b_{ki}$ . We are using summation convention here.

## Some Results From Differential Geometry (Cont'd)

- **Gauss Formula:**  $\hat{r}_{ij} = \Gamma_{ij}^k \hat{r}_k + b_{ij} \hat{n}$  where  $\Gamma_{ij}^k$  is Christoffel symbol of 2nd kind.
- **Christoffel Symbols:** First kind  $\Gamma_{ijk}$ , second kind  $\Gamma_{ij}^k$ ;

$$\Gamma_{ijk} = \frac{1}{2} \left[ \frac{\partial g_{jk}}{\partial u^i} + \frac{\partial g_{ki}}{\partial u^j} - \frac{\partial g_{ij}}{\partial u^k} \right] \quad \text{and} \quad \Gamma_{ijk} = \Gamma_{jik}$$

$$\Gamma_{ij}^k = g^{kl} \Gamma_{ijl} \quad \text{and} \quad \Gamma_{ij}^l = \Gamma_{ji}^l$$

**Note:** Christoffel symbols are not tensors while  $g_{ij}$ ,  $g^{ij}$ ,  $b_{ij}$ ,  $b^i_j$  are.

- A useful result:  $\frac{\partial \sqrt{g(2)}}{\partial u^i} = \Gamma_{ik}^k \sqrt{g(2)}$



## Some Results From Differential Geometry (Cont'd)

- Gauss Formula:

$$b = \partial_{12}^2 g_{12} - \frac{1}{2}(\partial_{22}^2 g_{11} + \partial_{11}^2 g_{22}) - (\Gamma_{11}^i \Gamma_{22}^j - \Gamma_{12}^i \Gamma_{21}^j) g_{ij}$$

$\partial_{ij}^2 = \partial^2 / \partial u^i \partial u^j$ . See theorema egregium of Gauss. A very significant result!

- Let us parametrize a curve in space by length parameter  $s$ .

The unit tangent  $\hat{t}$  to the curve is  $\hat{t} = \frac{d\vec{r}}{ds}$  and the local

curvature  $k$  is given by

$$k\hat{N} = \frac{d\hat{t}}{ds} = \hat{k}, k > 0$$

$$k = \left| \frac{d\hat{t}}{ds} \right| = \left| \frac{d^2\vec{r}}{ds^2} \right|$$

Note that  $\hat{N}$  always points to the center of curvature, i.e.  $\hat{N}$  is parallel to  $d\hat{t}/ds$ .

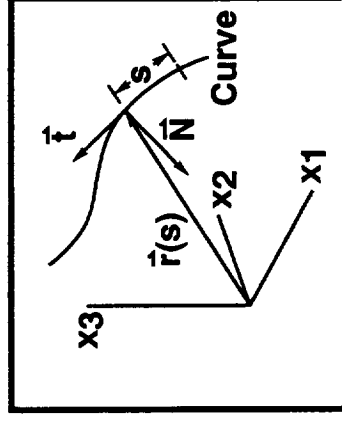

# Some Results From Differential Geometry (Cont'd)

- For a curve on a surface  $d^2\hat{r}/ds^2$  has components along tangent and normal to the surface.

$$\frac{d\hat{r}}{ds} = \hat{r}_i \frac{du^i}{ds}$$

$$\begin{aligned} \hat{k} &= \frac{d^2\hat{r}}{ds^2} = \hat{r}_{ij} \frac{du^i}{ds} \frac{du^j}{ds} + \hat{r}_i \frac{d^2u^i}{ds^2} \\ &= \underbrace{\left( \frac{d^2u^k}{ds^2} + \Gamma_{ij}^k \frac{du^i}{ds} \frac{du^j}{ds} \right)}_{\hat{k}_g: \text{Geodesic curvature vector}} \hat{r}_k + \underbrace{b_{ij} \frac{du^i}{ds} \frac{du^j}{ds}}_{\hat{k}_n: \text{Normal curvature vector}} \hat{n} \end{aligned}$$

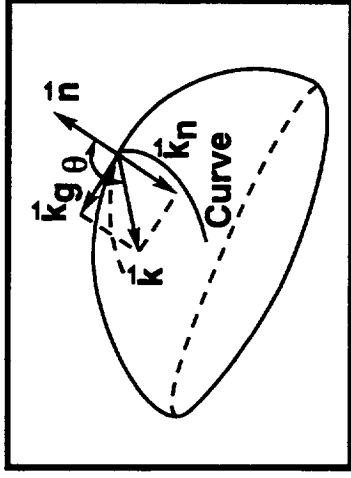

$$k = \frac{k_n}{\cos\theta}$$

Meusnier Theorem

Geodesic curvature is an *intrinsic* while normal curvature is an *extrinsic* quantity.

## Some Results From Differential Geometry (Cont'd)

- The normal curvature is a signed quantity. If  $k_n > 0$ , then the center of curvature of the curve obtained by intersection of a plane containing  $\hat{n}$  and the surface, is on the side  $\hat{n}$  points to. Note that  $t^i = \frac{du^i}{ds}$  the components of *unit tangent* to this curve and

$$k_n = b_{ij} t^i t^j. \text{ Note that } g_{ij} t^i t^j = 1.$$

- There are two directions at a point on a surface orthogonal to each other where  $k_n$  achieves its maximum and minimum values. These are known as the *principal directions* with *principal curvatures*  $k_1$  and  $k_2$  (normal curvatures).

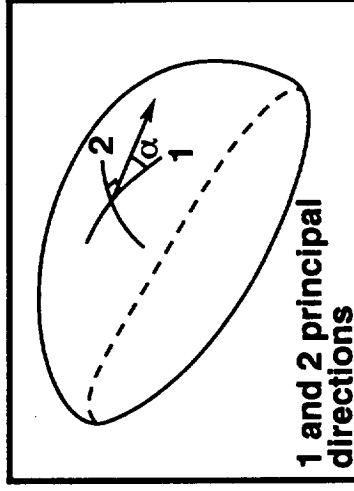
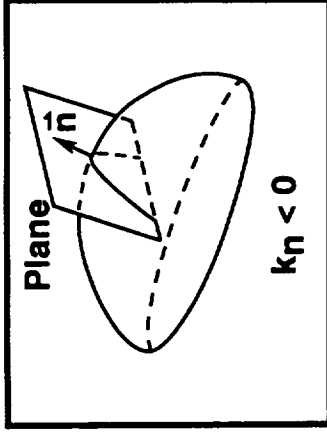

Euler's Formula

$$k_n(\alpha) = k_1 \cos^2 \alpha + k_2 \sin^2 \alpha$$

## Some Results From Differential Geometry (Cont'd)

- **Mean Curvature:**  $H = \frac{1}{2}(k_1 + k_2) = \frac{1}{2}b^i_i = \frac{1}{2}(b^1_1 + b^2_2)$ ,  $b^i_j = g^{ik}b_{kj}$
- **Gaussian Curvature:**  $K = k_1k_2 = b^1_1b^2_2 - b^1_2b^2_1$
- **Theorema Egregium of Gauss:** The Gaussian curvature  $K$  depends on  $g_{ij}$  and their first and second derivatives.

- We have  $K = \frac{b}{g}$ , and  $b$  was given in terms of  $g_{ij}$  and their first and second derivatives. Thus the Gaussian curvature is an *intrinsic* quantity.

- $\hat{n}_1 \times \hat{n}_2 = K \hat{r}_1 \times \hat{r}_2$   $\hat{r}_i = \frac{\partial \hat{r}}{\partial u^i}$ ,  $\hat{n}_i = \frac{\partial \hat{n}}{\partial u^i}$

- By Euler's formula

$$H = \frac{1}{2} \left[ k_n(\alpha) + k_n \left( \alpha + \frac{\pi}{2} \right) \right]$$

(1,2) Principal directions

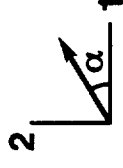

# Some Results From Differential Geometry (Cont'd)

- The *principal directions* can be found from solving the quadratic equation:

$$\begin{array}{|c|} \hline (du^2)^2 - du^1 du^2 \quad (du^1)^2 \\ \hline b_{11} \quad b_{12} \quad b_{22} \\ \hline g_{11} \quad g_{12} \quad g_{22} \\ \hline \end{array} = 0$$

Remember  $(du^1, du^2)$   
defines the direction  
 $\hat{r}_1 du^1 + \hat{r}_2 du^2$ .

- $H^2 \geq K$ ,  $H^2 = K$  if and only if the two fundamental forms are proportional.
- Let us displace surface  $S$  given by  $\hat{r}(u^1, u^2)$  by distance  $a = \text{const.}$  along local normal to get  $S'$  given by  $\hat{R}(u^1, u^2, a) = \hat{r}(u^1, u^2) + a\hat{n}(u^1, u^2)$ . If we associate prime quantities to  $S'$ , we can show the following

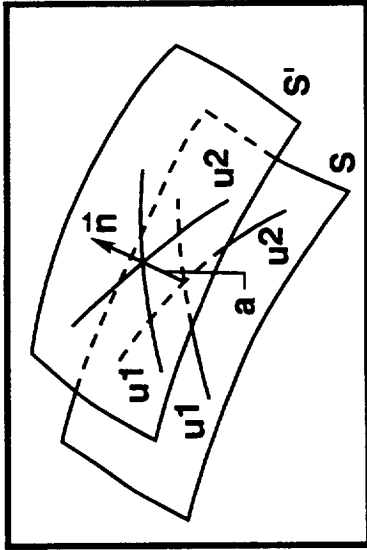

$$\begin{array}{|c|} \hline g'_2 = (1 - 2Ha + Ka^2)^2 g_2 \\ \hline \sqrt{g'_2} = (1 - 2Ha + Ka^2) \sqrt{g_2} \\ \hline \end{array}$$

$$H' = \frac{H - Ka}{1 - 2Ha + Ka^2}$$

$$K' = \frac{K}{1 - 2Ha + Ka^2}$$

## Some Results From Differential Geometry (Cont'd)

- If we now define  $u^3 = a$  be the distance along local normal to a surface  $S$ , then the three dimensional space near  $S$  can be parametrized by  $(u^1, u^2, u^3)$  and  $g_{(3)}$ , the determinant of coefficient of first fundamental form *in 3D* is given by

$$g_{(3)} = g'_{(2)}(u^1, u^2, u^3) = [1 - 2Hu^3 + K(u^3)^2]^2 g_2(u^1, u^2)$$

From this we find

$$\left( \frac{\partial \sqrt{g'_{(2)}}}{\partial u^3} \right)_{u^3=0} = \left( \frac{\partial \sqrt{g'_{(2)}}}{\partial n} \right)_S = -2H \sqrt{g_2}$$

Here  $H$  is the local mean curvature of the surface  $S$

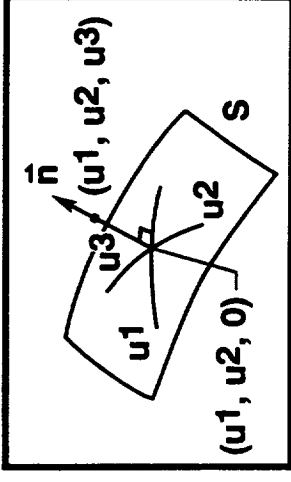

## Some Results From Differential Geometry (Cont'd)

- Let us now have a vector field  $\vec{Q}$  in the vicinity of surface  $S: f = 0$ . We want to write  $\nabla \cdot \vec{Q}$  in a new way. First parametrize the 3D space in the vicinity of  $S$  as shown. Then, let  $Q^i$  be the contravariant components of  $\vec{Q}$ . We have

$$\nabla \cdot \vec{Q} = \frac{1}{\sqrt{g(3)}} \frac{\partial}{\partial u^i} [\sqrt{g(3)} Q^i]$$

$g(3) = g'(2)(u^1, u^2, u^3)$ , we have, using  $\alpha = 1, 2$

$$(\nabla \cdot \vec{Q})_S = \left[ \frac{1}{\sqrt{g'(2)}} \frac{\partial}{\partial u^\alpha} [\sqrt{g'(2)} Q^\alpha] + \frac{\partial Q^3}{\partial u^3} + \frac{Q^3}{\sqrt{g'(2)}} \frac{\partial \sqrt{g'(2)}}{\partial u^3} \right]_S$$

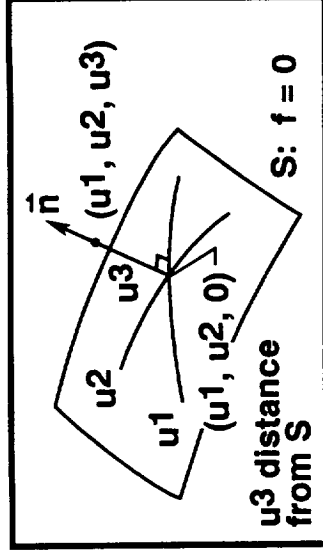

Now using the result of previous page that

## Some Results From Differential Geometry (Cont'd)

Since  $Q^3 = Q_n$ :

$$\boxed{(\nabla \cdot \vec{Q})_S = \nabla_2 \cdot \vec{Q}_T + \frac{\partial Q_n}{\partial n} - 2H_f Q_n}$$

A very useful result

$\vec{Q}_T = \vec{Q} - \vec{Q}_n$  surface component of  $\vec{Q}$  on  $S$ .

$\nabla_2 \cdot \vec{Q}_T$  is the *surface divergence* of  $\vec{Q}_T = Q^1 \hat{r}_1 + Q^2 \hat{r}_2$ :

$$\boxed{\nabla_2 \cdot \vec{Q}_T = \frac{1}{\sqrt{g(2)}} \frac{\partial}{\partial u^\alpha} [\sqrt{g(2)} Q^\alpha]}$$

$$\alpha = 1, 2$$

**Example:**  $\nabla \cdot [p \hat{n} \delta(f)] = \frac{\partial}{\partial n} [p \delta(f)] - 2H_f \delta(f) = p \delta'(f) - 2H_f \delta(f)$

where  $p$  is the restriction of  $p$  to  $f=0$  (explained later), and  $H_f$  is the mean curvature of  $f=0$ . Note that  $\partial p / \partial n = 0$ . This identity is used in deriving the supersonic Kirchhoff formula.



# **Integration of Delta Functions and Solution of Wave Equation**

F. Farassat, Aeroacoustics Branch  
Fluid Mechanics and Acoustics Division  
NASA Langley Research Center  
Hampton, Virginia

## The Integration of $\delta(f)$ and $\delta'(f)$

We assume  $f(\hat{x})$  is defined such that  $|\nabla f| = 1$  on the surface  $f = 0$ . This can always be done. This means  $df = du^3$

- Parametrize the space in vicinity of surface  $f = 0$  by variables  $(u^1, u^2, u^3)$  as shown. Then

$$I_1 = \int \phi(\hat{x}) \delta(f) d\hat{x}$$

$$d\hat{x} = \sqrt{g(3)} du^1 du^2 du^3$$

$$= \sqrt{g'(2)}(u^1, u^2, u^3) du^1 du^2 du^3$$

$$I_1 = \int \phi(\hat{x}) \delta(u^3) \sqrt{g'(2)} du^1 du^2 du^3 = \int [\phi(\hat{x})]_{u^3=0} \sqrt{g(2)} du^1 du^2$$

$$I_1 = \int_{f=0} \phi(\hat{x}) \delta(f) d\hat{x} = \int \phi(\hat{x}) ds$$

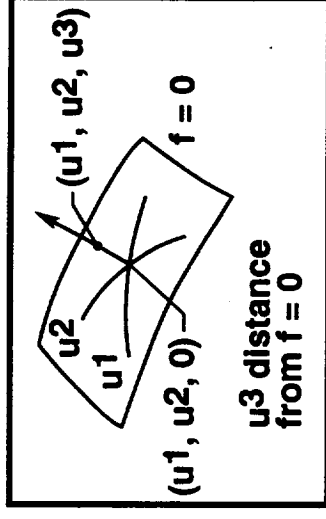

## The Integration of $\delta(f)$ and $\delta'(f)$ (Cont'd)

$$\begin{aligned}
 I_2 &= \int \phi(\hat{x}) \delta'(f) d\hat{x} = \int \phi(\hat{x}) \delta'(u^3) \sqrt{g'(2)} du^1 du^2 du^3 \\
 &= - \int \frac{\partial}{\partial u^3} [\phi(\hat{x}) \sqrt{g'(2)}] \Big|_{u^3=0} du^1 du^2 \\
 &= \int \left[ -\frac{\partial \phi}{\partial u^3} + 2H_f \phi \right] \sqrt{g(2)} du^1 du^2
 \end{aligned}$$

where we used  $(\partial \sqrt{g'(2)} / \partial u^3) \Big|_{u^3=0} = -2H_f \sqrt{g(2)}$ ,  $H_f$  local mean curvature on  $f=0$ .

$$I_2 = \int \phi(\hat{x}) \delta'(f) d\hat{x} = \int_{f=0} \left[ -\frac{\partial \phi}{\partial n} + 2H_f \phi \right] ds$$

# Integration of Product of Delta Functions

Let  $f(\hat{x}) = 0$  and  $g(\hat{x}) = 0$  be two intersecting surfaces in 3D. We want to integrate

$$I = \int \phi(\hat{x}) \delta(f) \delta(g) d\hat{x}$$

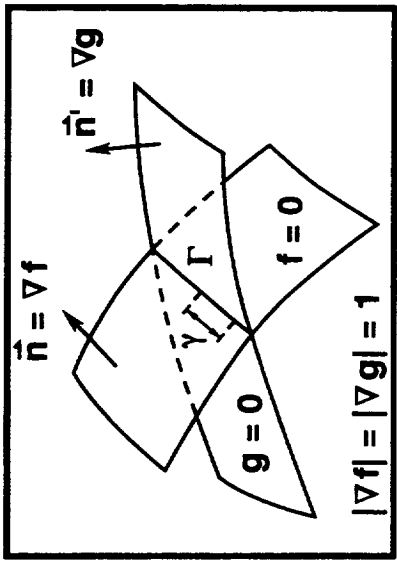

Let the two surfaces intersect along the curve  $\Gamma$ . On local plane normal to  $\Gamma$ , parametrize space by  $u^1 = f$ ,  $u^2 = g$ , and  $u^3 = \gamma$ , where  $\gamma$  is the distance along  $\Gamma$ . Extend  $u^1$  and  $u^2$  to the space in the vicinity of the plane along local normal to the plane.

# Integration of Product of Delta Functions (Cont'd)

Then

$$d\hat{x} = \frac{du^1 du^2 du^3}{\sin\theta}$$

$$\sin\theta = |\hat{n} \times \hat{n}'|$$

$$I = \int \frac{\phi(\hat{x})}{\sin\theta} \delta(u^1) \delta(u^2) du^1 du^2 du^3 = \int_{f=g=0} \frac{\phi(\hat{x})}{\sin\theta} du^3$$

$$I = \int_{f=0} \int_{g=0} \frac{\phi(\hat{x})}{\sin\theta} d\gamma$$

Also if  $|\nabla f| \neq 1$  or  $|\nabla g| \neq 1$

$$I = \int_{f=0} \int_{g=0} \frac{\phi(\hat{x})}{|\nabla f| |\nabla g| \sin\theta} d\gamma$$

# Illustration of Manipulation of Generalized Functions

Let  $\vec{Q}$  be a vector field which is zero outside  $\Omega$  and nonzero inside  $\Omega$ .

$$\Delta \vec{Q} = \vec{Q}(f = 0+) - \vec{Q}(f = 0-) = -\vec{Q}|_s$$

$$\bar{\nabla} \cdot \vec{Q} = \nabla \cdot \vec{Q} + \Delta \vec{Q} \cdot \vec{n} \delta(f) = \nabla \cdot \vec{Q} - Q_n \delta(f)$$

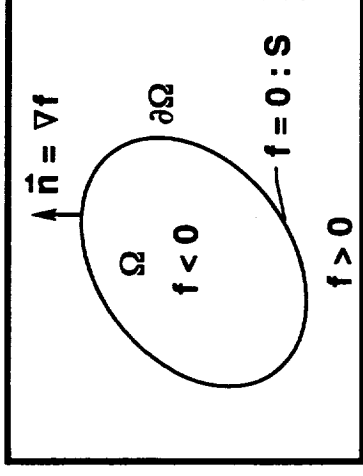

Now integrate  $\bar{\nabla} \cdot \vec{Q}$  over the entire 3D space.  $\int \bar{\nabla} \cdot \vec{Q} d\hat{x} = 0$  since

$$\int \frac{\partial Q_1}{\partial x_1} dx_1 dx_2 dx_3 = \int (Q_1|_{x_1=\infty} - Q_1|_{x_1=-\infty}) dx_2 dx_3 = 0$$

Similarly for  $\partial Q_2 / \partial x_2$  and  $\partial Q_3 / \partial x_3$ . Now, we have

$$\int \bar{\nabla} \cdot \vec{Q} d\hat{x} = \int [\nabla \cdot \vec{Q} - Q_n \delta(f)] d\hat{x} = \int_{\Omega} \nabla \cdot \vec{Q} d\hat{x} - \int_{\partial\Omega} Q_n dS = 0$$

# Illustration of Manipulation of Generalized Functions (Cont'd)

This is the *divergence theorem*. This result is valid if  $\vec{Q}$  is discontinuous across a surface  $g = 0$  inside  $\Omega$ .

$$\begin{aligned} \int_{\Omega} \vec{\nabla} \cdot \vec{Q} d\hat{x} &= \int_{\Omega} [\vec{\nabla} \cdot \vec{Q} + \Delta \vec{Q} \cdot \vec{n}' \delta(g)] d\hat{x} \\ &= \int_{\Omega} \vec{\nabla} \cdot \vec{Q} d\hat{x} + \int_{A_g} \Delta Q_{n'} dS = \int_{\partial\Omega} Q_n dS \end{aligned}$$

$$\int_{\Omega} \vec{\nabla} \cdot \vec{Q} d\hat{x} = \int_{\partial\Omega} Q_n dS - \int_{A_g} \Delta Q_{n'} dS$$

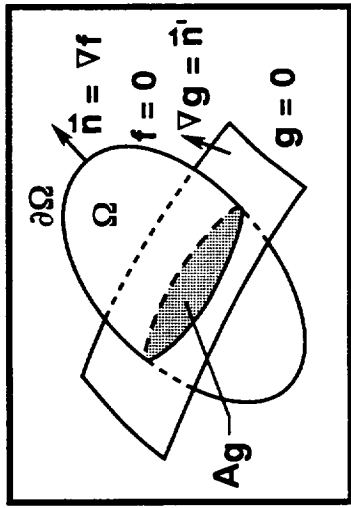

$$\Delta Q_{n'} = \vec{n}' \cdot [\vec{Q}(g = 0+) - \vec{Q}(g = 0-)]$$

# Illustration of Manipulation of Generalized Functions (Cont'd)

In deriving conservation laws in differential form from finite volumes involving discontinuous functions, whenever the divergence theorem is used to convert surface integrals into volume integrals, one should use generalized derivative. Such conservation laws have the jump conditions incorporated in them.

**Example: Shock Jump Conditions:** Let the shock surface be given by

$$f(\hat{x}, t) = 0, \nabla f = \hat{n}, \Rightarrow \frac{\partial f}{\partial t} = -v_n \text{ local shock normal speed,}$$

$$\text{mass continuity eq.:} \quad \bar{\frac{\partial \rho}{\partial t}} + \frac{\partial}{\partial x_i}(\rho u_i) = 0$$

$$\bar{\frac{\partial \rho}{\partial t}} + \frac{\partial}{\partial x_i}(\rho u_i) = \underbrace{\frac{\partial \rho}{\partial t} + \frac{\partial}{\partial x_i}(\rho u_i)}_{= 0} + \underbrace{\Delta \rho \frac{\partial f}{\partial t} \delta(f) + \Delta(\rho u_i) \frac{\partial f}{\partial x_i} \delta(f)}_{[-v_n \Delta \rho + \Delta(\rho u_n)] \delta(f)} = 0$$

$$\therefore \Delta[\rho(u_n - v_n)] = 0$$

Similarly for momentum and energy equations.



# Things to Know About Green's Function of Wave Equation

- The Green's function of the wave equation in the unbounded space is

$$G(\hat{y}, \tau; \hat{x}, t) = \begin{cases} \frac{\delta(g)}{4\pi r} & \tau \leq t \\ 0 & \tau > t \end{cases}$$

$$g = \tau - t + \frac{r}{c} \text{ outgoing wave}$$

$(\hat{y}, \tau)$  source space-time variables

$(\hat{x}, t)$  observer space-time variables

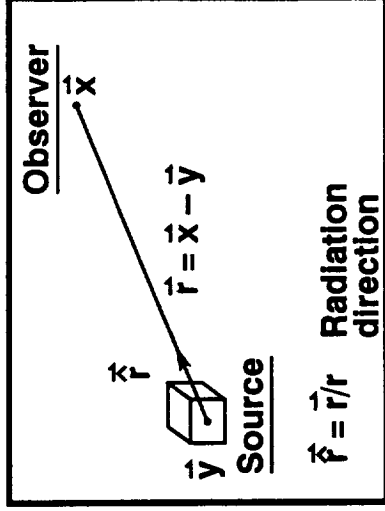

## Things to Know About Green's Function of Wave Equation

- There are many methods to derive  $G(\hat{y}, \tau; \hat{x}, t)$  rigorously. It is easy to show that  $G$  depends on  $\hat{x} - \hat{y}$  and  $t - \tau$ . Using  $\hat{x} - \hat{y} = \hat{r}$ ,  $\lambda = t - \tau$ , take *spatial* Fourier transform of  $\square^2(\hat{r}, \lambda)G = \delta(\hat{r})\delta(\lambda)$  to get a simple problem involving finding the Green's function of an O.D.E. in  $\lambda$ . The inverse spatial Fourier transform of the Green's function of the O.D.E. gives Green's function of the wave equation for both the outgoing and incoming waves.

$$\hat{r} = \hat{x} - \hat{y}, \quad r = |\hat{x} - \hat{y}|, \quad \hat{r} = \frac{\hat{r}}{r}, \quad \frac{\partial r}{\partial x_i} = \hat{r}_i, \quad \frac{\partial r}{\partial y_i} = -\hat{r}_i$$

*Useful things to remember*

F. Farassat, Aeroacoustics Branch  
Fluid Mechanics and Acoustics Division  
NASA Langley Research Center  
Hampton, Virginia

# Things to Know About Green's Function of Wave Equation

The support of  $\delta(g)$  is on the surface  $g = 0$ . The surface  $g = 0$  is  $r = |\hat{x} - \hat{y}| = c(t - \tau)$ . This is the *characteristic cone* of the wave equation with vertex at  $(\hat{x}, t)$ . Since  $\square^2$  is a differential equation with constant coefficients,  $g = 0$  is also the *characteristic conoid* with vertex at  $(\hat{x}, t)$ . This gives us the picture on the right. Note that we have drawn the 3D space  $\Omega$  as a plane in the figure. Therefore, this figure is a 3D illustration of what happens in 4D (3D space + time).

- **Note:**  $g = 0$  is a cone because if the 4-vector  $\hat{A} = (\hat{x} - \hat{y}, t - \tau)$  lies on  $g = 0 \Rightarrow \alpha \hat{A} = [\alpha(\hat{x} - \hat{y}), \alpha(t - \tau)]$  also lies on  $g = 0$ . This is the property of a cone.

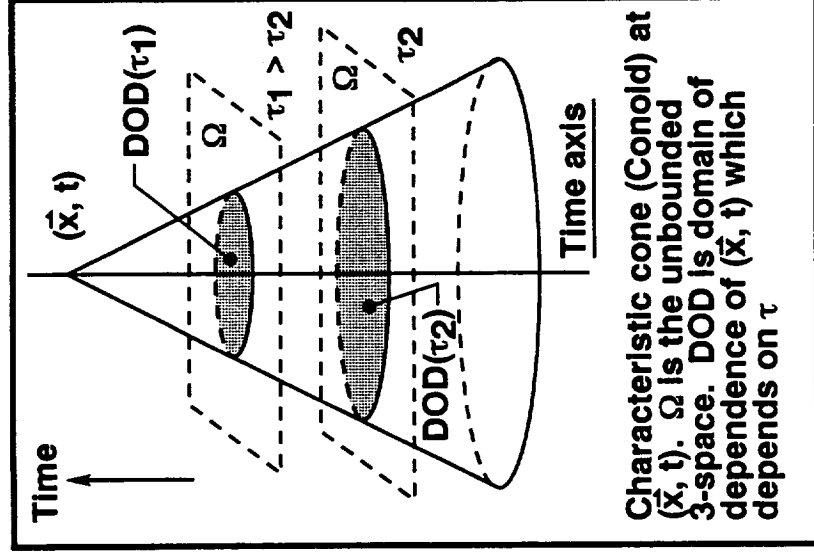

Characteristic cone (Conoid) at  $(\hat{x}, t)$ .  $\Omega$  is the unbounded 3-space. DOD is domain of dependence of  $(\hat{x}, t)$  which depends on  $\tau$

# Things to Know About Green's Function of Wave Equation

- *Visualization of domain of dependence of  $(\hat{x}, t)$  in four dimensions.*

Fix  $(\hat{x}, t)$  and  $\tau \Rightarrow r = c(t - \tau)$  is a sphere with center at  $\hat{x}$  and radius  $c(t - \tau)$ . Any source on this sphere at time  $\tau$ , contributes to  $\hat{x}$  at time  $t$ . As  $\tau$  increases, the radius shrinks, hence we have a *collapsing sphere*. Radius becomes zero at  $\tau = t$ .

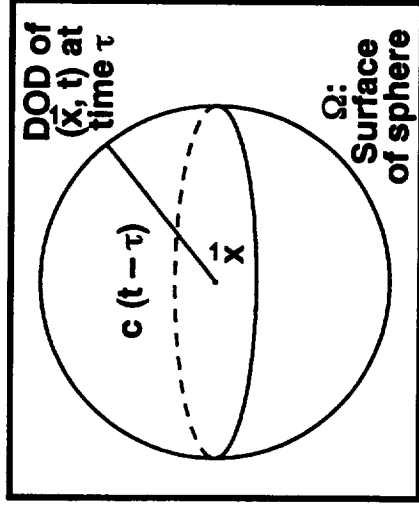

# The Collapsing Sphere Concept

Equation of collapsing sphere:  $r = c(t - \tau)$ ,  $(\hat{x}, t)$  fixed

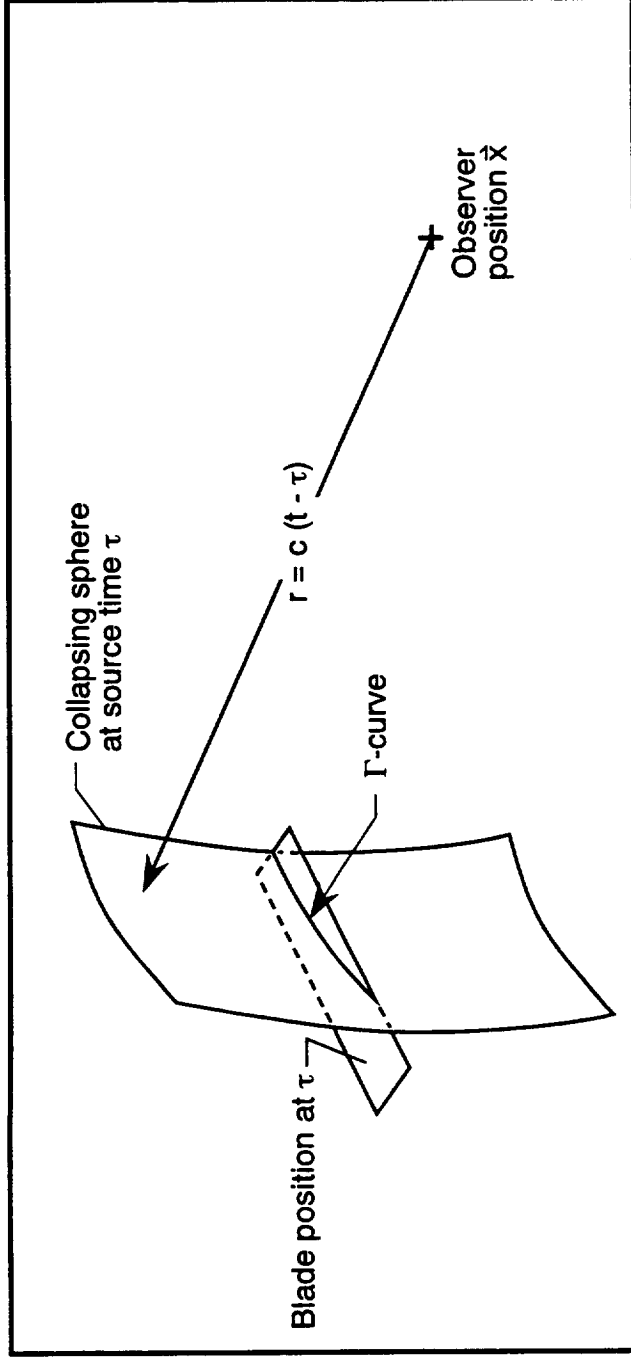

The  $\Sigma$ -surface is the locus of  $\Gamma$ -curves in space. If the blade surface is described by  $f(\hat{y}, \tau) = 0$ , the equation of the  $\Sigma$ -surface is:

$$F(\hat{y}; \hat{x}, t) = [f(\hat{y}, \tau)]_{\text{ret}} = f(\hat{y}, t - r/c) = 0, (\hat{x}, t) \text{ fixed}$$

F. Farassat, Aeroacoustics Branch  
 Fluid Mechanics and Acoustics Division  
 NASA Langley Research Center  
 Hampton, Virginia

# Construction of $\Sigma$ -Surface for a Helicopter Rotor Blade

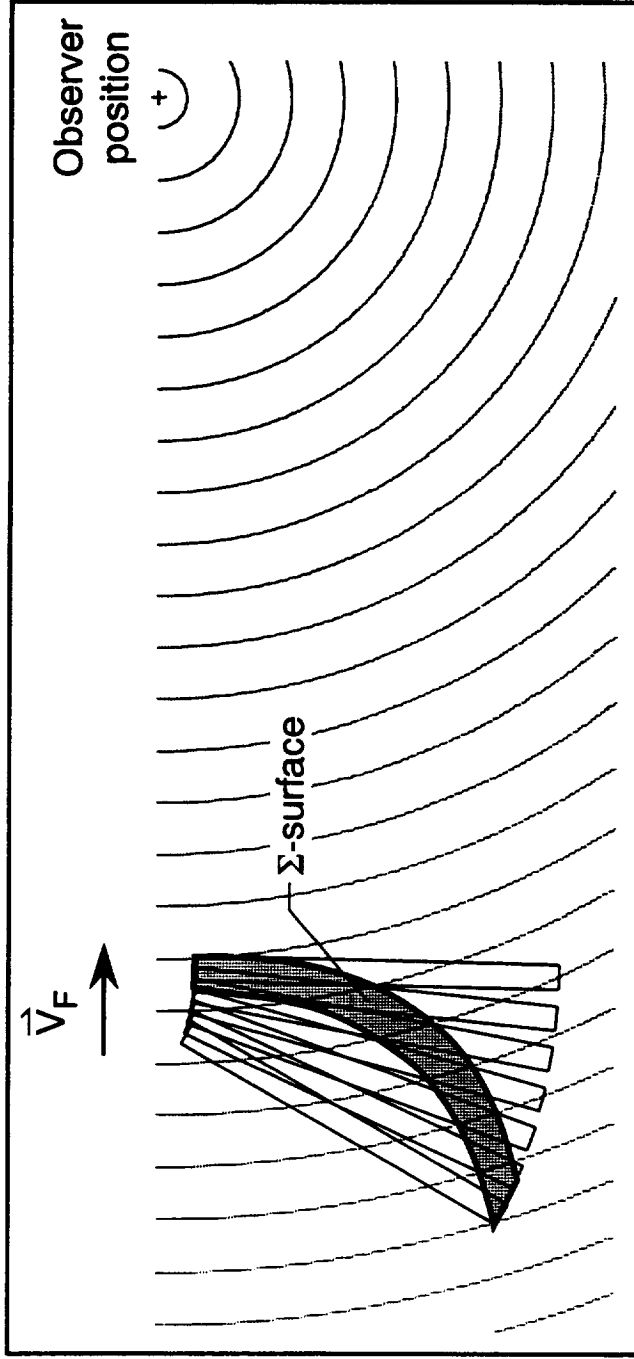

In this construction, we have taken a rotor blade of zero thickness rotating with rotational Mach number 0.67 and forward Mach number 0.15. The observer is in the rotor plane. The circles are the intersection of the collapsing sphere with the plane containing the rotor. The circles are drawn at equal source time intervals. The observer time is  $t = \tau + r/c$  where  $r$  is the radius of the collapsing sphere at  $\tau$ . Note that  $t$  is fixed for the above  $\Sigma$ -surface.

# Use of Green's Functions for Discontinuous Solutions

Green's function can be used to find discontinuous solutions if the derivatives in the differential equation are treated as generalized derivatives. This adds to usefulness of Green's function.

**Example:** *Green's Identity for Laplace Equation*

$$\text{Let } \tilde{\phi}(\hat{x}) = \begin{cases} \phi(\hat{x}) & \hat{x} \in \Omega \\ 0 & \hat{x} \notin \Omega \end{cases} \Rightarrow \nabla^2 \tilde{\phi} = 0 \text{ everywhere.}$$

$$\bar{\nabla} \tilde{\phi} = \nabla \tilde{\phi} + \Delta \tilde{\phi} \hat{n} \delta(f) = \nabla \tilde{\phi} - \phi \hat{n} \delta(f)$$

$$\begin{aligned} \bar{\nabla}^2 \tilde{\phi} &= \nabla^2 \tilde{\phi} - \nabla \phi \cdot \hat{n} \delta(f) - \nabla \cdot [\phi \hat{n} \delta(f)] \\ &= -\frac{\partial \phi}{\partial n} \delta(f) - \nabla \cdot [\phi \hat{n} \delta(f)] \end{aligned}$$

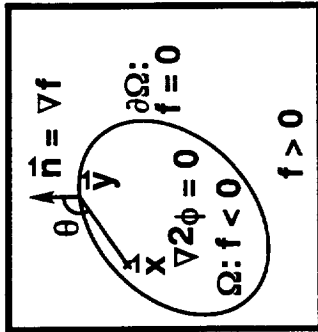

Interior Problem

# Use of Green's Functions for Discontinuous Solutions (Cont'd)

Since this equation is valid in the unbounded space, we can use the Green's function  $-\frac{1}{4\pi r}$  to get the Green's identity

$$\begin{aligned} 4\pi\tilde{\phi}(\hat{x}) &= \int \frac{1}{r} \frac{\partial\phi}{\partial n} \delta(f) d\hat{y} + \nabla_{\hat{x}} \cdot \int \frac{\phi\hat{n}}{r} \delta(f) d\hat{y} \\ &= \int_{f=0} \frac{1}{r} \frac{\partial\phi}{\partial n} dS + \nabla_{\hat{x}} \cdot \int_{f=0} \frac{\phi\hat{n}}{r} dS = \int_{f=0} \frac{\phi n}{r} dS - \int_{f=0} \frac{\phi \cos\theta}{r^2} dS \end{aligned}$$

This method tells us that when  $\hat{x} \notin \Omega$ ,  $\tilde{\phi} = 0$  which is not obvious from the classical derivation. The exterior problem is similar.

**Note:**  $r = |\hat{x} - \hat{y}|$  is the only term in the integrands of the above integrals which is a function of  $\hat{x}$ . We assume that  $\hat{x}$  is not located on  $S$  and  $S$  is piecewise smooth. The justification for the exchange of the divergence and integral operators follows from classical analysis.



# The Two Forms of the Solution of Wave Equation (Volume Sources)

We want to find the solution of  $\square^2 \phi = Q(\hat{x}, t)$

$$4\pi\phi(\hat{x}, t) = \int \frac{1}{r} Q(\hat{y}, \tau) \delta(g) d\hat{y} d\tau$$

All volume integrals are over unbounded 3 space and all time integrals are over  $(-\infty, t)$ .

i) Let  $\tau \rightarrow g \Rightarrow \frac{\partial g}{\partial \tau} = 1$  and  $4\pi\phi(\hat{x}, t) = \int \frac{1}{r} Q(\hat{y}, g + t - \frac{r}{c}) \delta(g) dg d\hat{y}$

Integrate with respect to  $g$  to get

$$4\pi\phi(\hat{x}, t) = \int \frac{1}{r} Q(\hat{y}, t - \frac{r}{c}) d\hat{y} = \int \frac{[Q]_{\text{ret}}}{r} d\hat{y}$$

*Retarded Time Solution*

# The Two Forms of the Solution of Wave Equation (Volume Sources) (Cont'd)

ii) Let  $y_3 \rightarrow g \Rightarrow \frac{\partial g}{\partial y_3} = -\frac{1}{c} \hat{r}_3$

$$4\pi\phi(\hat{x}, t) = \int \frac{cQ(\hat{y}, \tau)}{r} \delta(g) dg \frac{dy_1 dy_2}{|\hat{r}_3|} d\tau$$

Since in the inner integrals  $(\hat{x}, t)$  and  $\tau$  are fixed, then  $\frac{dy_1 dy_2}{|\hat{r}_3|} = d\Omega$  element of surface area of sphere  $r = c(t - \tau)$ . Integrate with respect to  $g$  to get:

$$4\pi\phi(\hat{x}, t) = \int_{-\infty}^t \frac{d\tau}{t - \tau} \int_{r=c(t-\tau)} Q(\hat{y}, \tau) d\Omega$$

*Collapsing Sphere Solution*

F. Farassat, Aeroacoustics Branch  
Fluid Mechanics and Acoustics Division  
NASA Langley Research Center  
Hampton, Virginia

# **Derivation of the Stationary, Subsonic and Supersonic Kirchhoff Formulas**

F. Farassat, Aeroacoustics Branch  
Fluid Mechanics and Acoustics Division  
NASA Langley Research Center  
Hampton, Virginia

# The Governing Wave Equation for Deriving Kirchhoff Formulas

We consider *the exterior problem* here.

$\bar{\Omega}$ : The exterior unbounded space

$$\text{Let } \tilde{\phi}(\hat{x}, t) = \begin{cases} \phi(\hat{x}, t) & \hat{x} \in \bar{\Omega} \\ 0 & \hat{x} \notin \bar{\Omega} \end{cases} \Rightarrow \square^2 \tilde{\phi} = 0 \text{ everywhere}$$

$$\bar{\frac{\partial \tilde{\phi}}{\partial t}} = \frac{\partial \tilde{\phi}}{\partial t} + \phi \frac{\partial f}{\partial t} \delta(f) = \frac{\partial \tilde{\phi}}{\partial t} - \nu_n \phi \delta(f)$$

where  $\nu_n = -\frac{\partial f}{\partial t}$  is the local normal velocity on  $f = 0$

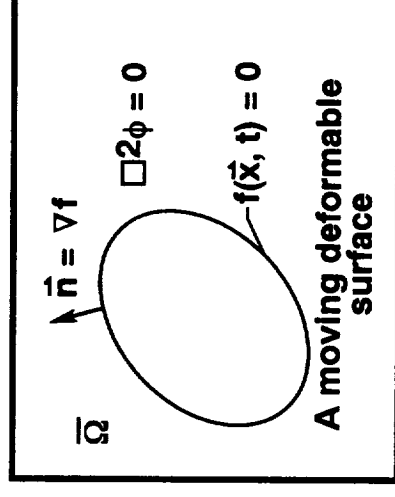

# The Governing Wave Equation for Deriving Kirchhoff Formulas (Cont'd)

Next take the second time derivative of  $\tilde{\phi}$ :

$$\bar{\partial}^2 \tilde{\phi} = \frac{\partial^2 \tilde{\phi}}{\partial t^2} + \frac{\partial \phi}{\partial t} \frac{\partial f}{\partial t} \delta(f) - \frac{\partial}{\partial t} [\nu_n \phi \delta(f)] = \frac{\partial^2 \tilde{\phi}}{\partial t^2} - \nu_n \phi_t \delta(f) - \frac{\partial}{\partial t} [\nu_n \phi \delta(f)]$$

Similarly for the space derivatives we have:

$$\bar{\nabla} \tilde{\phi} = \nabla \tilde{\phi} + \phi \dot{n} \delta(f), \quad \bar{\nabla}^2 \tilde{\phi} = \nabla^2 \tilde{\phi} + \phi_n \delta(f) + \nabla \cdot [\phi \dot{n} \delta(f)]$$

The above results give:

$$\begin{aligned} \bar{\square}^2 \tilde{\phi} &= \frac{1}{c^2} \frac{\partial^2 \tilde{\phi}}{\partial t^2} - \bar{\nabla}^2 \tilde{\phi} = \square^2 \tilde{\phi} - \left( \frac{\nu_n \phi_t}{c^2} + \phi_n \right) \delta(f) \\ &\quad - \frac{1}{c^2} \frac{\partial}{\partial t} [\nu_n \phi \delta(f)] - \nabla \cdot [\phi \dot{n} \delta(f)] \end{aligned}$$

# The Governing Wave Equation for Deriving Kirchhoff Formulas (Cont'd)

Since  $\square^2 \tilde{\phi} = 0$ , and using  $M_n = v_n/c$ , we get

$$\square^2 \tilde{\phi} = - \left( \phi_n + \frac{1}{c} M_n \phi_t \right) \delta(f) - \frac{1}{c} \frac{\partial}{\partial t} [M_n \phi \delta(f)] - \nabla \cdot [\phi \hat{n} \delta(f)]$$

We now solve this wave equation for stationary, subsonic and supersonic surfaces.

## Derivation of the Classical Kirchhoff Formula

The Kirchhoff surface  $f(\hat{x})$  is now stationary so that  $M_n = 0$ . The governing

wave equation is

$$\boxed{\nabla^2 \tilde{\phi} = -\phi_n \delta(f) - \nabla \cdot [\phi \hat{n} \delta(f)]}$$

$$4\pi \tilde{\phi}(\hat{x}, t) = -\int \frac{\phi}{r} \delta(f) \delta(g) d\hat{y} d\tau - \nabla_{\hat{x}} \cdot \int \frac{\phi \hat{n}}{r} \delta(f) \delta(g) d\hat{y} d\tau$$

where  $\phi_n$  and  $\phi$  in the integrands are functions of  $(\hat{y}, \tau)$ . Now let  $\tau \rightarrow g$ ,  $\frac{\partial g}{\partial \tau} = 1$ , and integrate with respect to  $g$ , to get

$$4\pi \tilde{\phi}(\hat{x}, t) = -\int \frac{\phi_n(\hat{y}, t - r/c)}{r} \delta(f) d\hat{y} - \nabla_{\hat{x}} \cdot \int \frac{\phi(\hat{y}, t - r/c) \hat{n}}{r} \delta(f) d\hat{y}$$

We have dealt with these integrals before. The integration of  $\delta(f)$  gives

$$4\pi \tilde{\phi}(\hat{x}, t) = -\int_{f=0} \frac{1}{r} \phi_n(\hat{y}, t - r/c) dS - \nabla_{\hat{x}} \cdot \int_{f=0} \frac{\hat{n}}{r} \phi(\hat{y}, t - r/c) dS$$

## Derivation of the Classical Kirchhoff Formula (Cont'd)

Taking the divergence operator in and using subscript ret for retarded time, we get the *classical Kirchhoff formula*

$$4\pi\tilde{\phi}(\hat{x}, t) = \int_{f=0} \frac{[c^{-1}\dot{\phi}\cos\theta - \phi]_{n\text{ret}}}{r} dS + \int_{f=0} \frac{\cos\theta}{r^2} [\phi]_{\text{ret}} dS$$

In this equation  $\cos\theta = \hat{n} \cdot \hat{r}$ . Again, our method tells that  $\tilde{\phi}(\hat{x}, t) = 0$  in the interior of  $f=0$  which is not obvious from classical derivation.

**Note:** Only  $r$  is a function of  $\hat{x}$  in the integrands of the integrals in previous vugraph. We assume  $\hat{x}$  is not on  $S$  and  $S$  is piecewise smooth. The justification for bringing the divergence operator inside the integral follows from classical analysis.



## Derivation of the Subsonic Kirchhoff Formula

We now assume a deformable surface moving at subsonic speed.

**Governing equation:**

$$\square^2 \tilde{\phi} = -(\phi_n + c^{-1} M_n \phi_t) \delta(f) - \frac{1}{c} \frac{\partial}{\partial t} [M_n \phi \delta(f)] - \nabla \cdot [\phi \hat{n} \delta(f)]$$

$$4\pi \tilde{\phi}(\hat{x}, t) = -\int \frac{1}{r} (\phi_n + c^{-1} M_n \phi_\tau) \delta(f) \delta(g) d\hat{y} d\tau$$

$$- \frac{1}{c} \frac{\partial}{\partial t} \int \frac{1}{r} M_n \phi \delta(f) \delta(g) d\hat{y} d\tau$$

$$- \nabla_{\hat{x}} \cdot \int \frac{1}{r} \phi_n \delta(f) \delta(g) d\hat{y} d\tau$$

Note that in the above equation  $\phi_\tau = \frac{\partial \phi(\hat{y}, \tau)}{\partial \tau}$ .

## Derivation of the Subsonic Kirchhoff Formula (Cont'd)

In the last integral, take divergence operator in. It only must operate on  $\frac{\delta(g)}{r}$

which depends on  $\hat{x}$ . Now use the following result to write the last integral as two integrals:

$$\nabla_{\hat{x}} \left[ \frac{\delta(g)}{r} \right] = -\frac{1}{c} \frac{\partial}{\partial t} \left[ \frac{\hat{r} \delta(g)}{r} \right] - \frac{\hat{r} \delta(g)}{r^2}, \quad \hat{r} = \frac{\hat{r}}{r}$$

$$\begin{aligned} \nabla_{\hat{x}} \cdot \int \frac{1}{r} \phi \hat{n} \delta(f) \delta(g) d\hat{y} d\tau &= \int \phi \delta(f) \hat{n} \cdot \nabla_{\hat{x}} \left[ \frac{\delta(g)}{r} \right] d\hat{y} d\tau \\ &= -\frac{1}{c} \frac{\partial}{\partial t} \int \frac{1}{r} \phi \cos \theta \delta(f) \delta(g) d\hat{y} d\tau \\ &\quad - \int \frac{1}{r^2} \phi \cos \theta \delta(f) \delta(g) d\hat{y} d\tau \end{aligned}$$

Substitute in equation for  $\tilde{\phi}$  above. We have used the rule for the exchange of limit processes for generalized functions here.

## Derivation of the Subsonic Kirchhoff Formula (Cont'd)

$$\begin{aligned}
 4\pi\tilde{\phi}(\hat{x}, t) = & - \int \frac{1}{r}(\phi_n + c^{-1}M_n\phi_\tau)\delta(f)\delta(g)d\hat{y}d\tau \\
 & + \int \frac{1}{r^2}\phi\cos\theta\delta(f)\delta(g)d\hat{y}d\tau \\
 & + \frac{1}{c}\frac{\partial}{\partial t}\int \frac{1}{r}(\cos\theta - M_n)\phi\delta(f)\delta(g)d\hat{y}d\tau
 \end{aligned}$$

We have two kinds of integrals in the above equation

$$I_1 = \int Q_1(\hat{y}, \tau)\delta(f)\delta(g)d\hat{y}d\tau$$

$$I_2 = \frac{1}{c}\frac{\partial}{\partial t}\int Q_2(\hat{y}, \tau)\delta(f)\delta(g)d\hat{y}d\tau$$

## Derivation of the Subsonic Kirchhoff Formula (Cont'd)

- Let us parametrize  $S$ :  $f(\hat{y}, \tau) = 0$  by surface coordinates  $(u^1, u^2)$  with domain  $D(S)$ . We assume  $D(S)$  is time independent. This is always possible. But  $g_{(2)}$ , the det. of coef. of 1st fund. form is a function of time  $\tau$ . Parametrize the space near  $f = 0$  by taking  $u^3 = f$  and extend  $(u^1, u^2)$  along local normal to  $f = 0$ . Now we have  $d\hat{y} = \sqrt{g_{(2)}} du^1 du^2 du^3$  (strictly speaking, we should use  $g'_{(2)}$  but it makes no difference here).

We use  $Q_1(u^1, u^2, u^3, \tau)$  for  $Q_1[\dot{y}(u^1, u^2, u^3, \tau), \tau]$  in  $I_1$

$$\begin{aligned} I_1 &= \int Q_1(u^1, u^2, u^3, \tau) \delta(u^3) \delta(g) \sqrt{g_{(2)}} du^1 du^2 du^3 d\tau \\ &= \int_{-\infty}^t \int_{D(S)} Q_1(u^1, u^2, 0, \tau) \delta(g) \sqrt{g_{(2)}} du^1 du^2 d\tau \end{aligned}$$

## Derivation of the Subsonic Kirchhoff Formula (Cont'd)

Now let  $\tau \rightarrow g$ ,  $\frac{\partial g}{\partial \tau} = 1 - M_r$ , because  $g = \tau - t + |\hat{x} - \hat{y}(u^1, u^2, 0, \tau)|/c$ ,

$$\hat{M} = \frac{\partial \hat{y}(u^1, u^2, 0, \tau)}{\partial \tau}, \quad M_r = \hat{M} \cdot \hat{r} \Rightarrow$$

$$I_1 = \int_{D(S)} \left[ \frac{Q_1 \sqrt{g(2)}}{1 - M_r} \right]_{\tau^*} du^1 du^2$$

Here  $\tau^*$  is the *emission time* of point  $(u^1, u^2)$  on  $f = 0$  for a fixed  $(\hat{x}, t)$ .

The emission time  $\tau^*$  is the solution of:

$$\tau^* - t + |\hat{x} - \hat{y}(u^1, u^2, 0, \tau^*)|/c = 0$$

# Derivation of the Subsonic Kirchhoff Formula (Cont'd)

Similar procedure for  $I_2$  gives

$$I_2 = \frac{1}{c} \int_{D(S)} \frac{\partial}{\partial t} \left( \frac{Q_{2\sqrt{g(2)}}}{1-M_r} \right) \tau^* du^1 du^2$$

$$I_2 = \frac{1}{c} \int_{D(S)} \left[ \frac{1}{1-M_r} \left[ \frac{\partial}{\partial \tau} \left( \frac{Q_{2\sqrt{g(2)}}}{1-M_r} \right) \right] \right] \tau^* du^1 du^2$$

We note that  $\tau^* = \tau^*(u^1, u^2; \hat{x}, t)$  so that  $\frac{\partial}{\partial t} \Big|_{\hat{x}} = \frac{\partial \tau^*}{\partial t} \frac{\partial}{\partial \tau^*}$ . From the equation

$$\frac{\partial \tau^*}{\partial t} = \frac{1}{1-M_r}$$

for emission time

# Derivation of the Subsonic Kirchhoff Formula (Cont'd)

From the results for  $I_1$  and  $I_2$ , we get

$$\begin{aligned}
 4\pi\tilde{\phi}(\hat{x}, t) = & - \int_{D(S)} \left[ \frac{(\phi_n + c^{-1}M_n\phi_\tau)\sqrt{g(2)}}{r(1-M_r)} \right]_{\tau^*} du^1 du^2 \\
 & + \int_{D(S)} \left[ \frac{\phi\sqrt{g(2)}\cos\theta}{r^2(1-M_r)} \right]_{\tau^*} du^1 du^2 \\
 & + \frac{1}{c} \int_{D(S)} \left[ \frac{1}{1-M_r} \frac{\partial}{\partial\tau} \left( \frac{(\cos\theta - M_n)\phi\sqrt{g(2)}}{r(1-M_r)} \right) \right]_{\tau^*} du^1 du^2
 \end{aligned}$$

## Derivation of the Subsonic Kirchhoff Formula (Cont'd)

- This result was originally derived by W. R. Morgans (Phil. Mag., vol. 9, 1930, 141–161). It was rederived by Farassat and Myers using the above method (JSV, vol. 123(3), 1988, 451–460). These authors have given a useful formula for applications in the following form

$$4\pi\tilde{\phi}(\dot{x}, t) = \int_{D(S)} \left[ \frac{E_1 \sqrt{g(2)}}{r(1-M_r)} \right]_{\tau^*} du^1 du^2 + \int_{D(S)} \left[ \frac{\phi E_2 \sqrt{g(2)}}{r^2(1-M_r)} \right]_{\tau^*} du^1 du^2$$

✂

where  $E_1$  and  $E_2$  are long expressions given in the above reference. This formula was verified by using analytic input for rigid surfaces.

- **Note:** The above Kirchhoff formula has a Doppler singularity in the denominator for supersonic surfaces. This makes the above result unsuitable for a supersonic surface. However, the supersonic Kirchhoff formula is inherently less efficient on a computer. We prefer to use the above formula for any panel on the Kirchhoff surface without the Doppler singularity.



# A Simple Trick in Preparation for Supersonic Kirchhoff Formula

To reduce algebraic manipulations and to obtain the simplest form of the supersonic Kirchhoff formula, we introduce the following trick. Note that in the governing wave equation for deriving Kirchhoff formula, we have terms involving time and space derivatives:  $\frac{\partial}{\partial t}[M_n \phi \delta(f)]$  and  $\nabla \cdot [\phi \hat{n} \delta(f)]$ . We need to take these derivatives explicitly. We propose the following simplification of this process.

**Observation:**  $\phi(x)\delta(x) = \phi(0)\delta(x)$  take derivatives of both sides  $\phi'(x)\delta(x) + \phi(x)\delta'(x) = \phi(0)\delta'(x)$ . It is obvious that the right side is simpler than the left side. What is so special about  $\phi(0)\delta(x)$ ? Here  $\phi(x)$  is *restricted* to the support of the delta function, i.e.,  $x = 0$ . Can restriction of  $\phi(\hat{x})$  to the support of  $\delta(f)$  in  $\phi(\hat{x})\delta(f)$  reduce manipulations when we take derivatives of  $\phi(\hat{x})\delta(f)$ ? The answer is yes!

## A Simple Trick in Preparation for Supersonic Kirchhoff Formula (Cont'd)

We use the notation  $\phi(\underline{x})$  for restriction of  $\phi(\underline{x}, t)$  to the support of  $\delta(f)$ .

Using the local parametrization of space near  $f=0$  ( $(u^1, u^2)$  on  $f=0$ ,

$u^3 =$  distance from  $f=0$ ), we have  $\phi(\underline{x}) = \phi(u^1, u^2, 0)$

Similarly  $\phi(\underline{x}, t) = \phi(u^1, u^2, 0, t)$ , note  $u^i = u^i(\underline{x}, t)$  we have

$$\phi(\underline{x}, t)\delta(f) = \phi(\underline{x}, t)\delta(f)$$

See NASA TP-3428 for some more explanation. In manipulation of term involving derivatives of the product of a delta function and an ordinary function, always restrict the ordinary function to the support of the delta function.

## A Simple Trick in Preparation for Supersonic Kirchhoff Formula (Cont'd)

$$\nabla[\phi(\vec{x}, t)\delta(f)] = \nabla\phi\delta(f) + \phi\nabla f\delta'(f) \quad (\text{A})$$

$$\nabla[\phi(\vec{x}, t)\delta(f)] = \nabla_2\phi\delta(f) + \phi\nabla f\delta'(f) \quad (\text{B})$$

where  $\nabla_2\phi$  is the surface gradient of  $\phi$ . As expected, the integration of the right side of (A) is algebraically somewhat more complicated than integration of the right side of (B).

$$\frac{\partial\phi}{\partial x_i} = \frac{\partial\phi}{\partial x_i} - n_i \frac{\partial\phi}{\partial n},$$

$$\frac{\partial\phi}{\partial n} = 0,$$

$$\frac{\partial\phi}{\partial t} = \frac{\partial\phi}{\partial t} + v \frac{\partial\phi}{\partial n}$$

• Note that

$$\frac{\partial\phi}{\partial x_i} \text{ and } \frac{\delta\phi}{\delta t} \text{ for } \frac{\partial\phi}{\partial t}.$$

**Note:** Wave propagation literature use  $\frac{\delta\phi}{\delta x_i}$  for  $\frac{\partial\phi}{\partial x_i}$  and  $\frac{\delta\phi}{\delta t}$  for  $\frac{\partial\phi}{\partial t}$ .

# Derivation of the Supersonic Kirchhoff Formula

We are now interested to develop the supersonic Kirchhoff formula for a panel on the Kirchhoff surface. This is only because of practical consideration. On the surface  $f(\hat{x}, t) = 0$ , we define a panel by its edge

curve  $\tilde{f} = 0$  such that  $\tilde{f} > 0$  on the panel and

$\nabla \tilde{f} = \hat{v}$  the local unit geodesic normal at the edge  
 $f = \tilde{f} = 0$ . The geodesic normal is tangent to the panel and normal to the edge. Denoting Heaviside

function by  $H(\tilde{f})$ , our governing differential equation for finding the Kirchhoff formula *for the panel* is

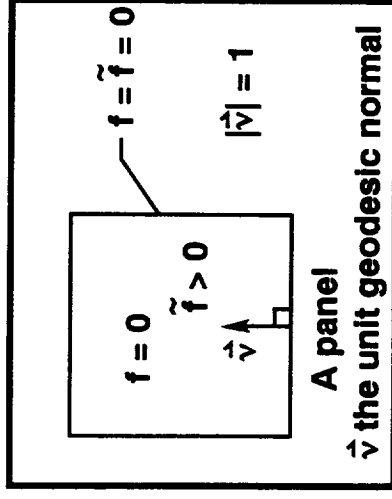

$$\square^2 \phi = -(\phi_n + c^{-1} M_n \phi_t) H(\tilde{f}) \delta(f) - \frac{1}{c} \frac{\partial}{\partial t} [M_n \phi H(\tilde{f}) \delta(f)] - \nabla \cdot [\phi \hat{n} H(\tilde{f}) \delta(f)]$$

## Derivation of the Supersonic Kirchhoff Formula (Cont'd)

$$\frac{1}{c} \frac{\partial}{\partial t} [M_n \phi H(\tilde{f}) \delta(f)] = \frac{1}{c} \frac{\partial}{\partial t} (M_n \phi) H(\tilde{f}) \delta(f) - M_n M_{\nu} \phi \delta(\tilde{f}) \delta(f) - M_n^2 \phi H(\tilde{f}) \delta'(f)$$

where  $M_{\nu} = \vec{M} \cdot \hat{\nu}$  is the local Mach number of the edge in the direction of  $\hat{\nu}$ . Using the divergence result derived earlier, we have

$$\nabla \cdot [\phi \hat{n} H(\tilde{f}) \delta(f)] = -2H_f \phi H(\tilde{f}) \delta(f) + \phi H(\tilde{f}) \delta'(f)$$

where  $H_f$  is the local mean curvature of  $f = 0$ .

# Derivation of the Supersonic Kirchhoff Formula (Cont'd)

The governing equation for deriving the supersonic Kirchhoff formula for a panel is

$$\begin{aligned} \bar{\square}^2 \tilde{\phi} &= - [\phi_n + c^{-1} M_n \phi_t + c^{-1} (M_n \phi)_{\tilde{t}} - 2H_f \phi] H(\tilde{f}) \delta(f) \\ &\quad - (1 - M_n^2) \phi H(\tilde{f}) \delta'(f) + M_n M_v \phi \delta(\tilde{f}) \delta(f) \\ &\equiv q_1 H(\tilde{f}) \delta(f) + q_2 H(\tilde{f}) \delta'(f) + q_3 \delta(\tilde{f}) \delta(f) \end{aligned}$$

We see that we have three kinds of sources which we will treat below.

- **Note:** The solution of wave equation with sources of the type in the above equation is given in detail in NASA Technical Paper 3428, May 1994, by F. Farassat.

## Derivation of the Supersonic Kirchhoff Formula (Cont'd)

Let  $\tilde{\phi} = \phi_1 + \phi_2 + \phi_3$  where  $\phi_i$ 's are solutions of wave equation with sources involving  $q_i$  ( $i = 1 - 3$ ).

$$\bar{\square}^2 \phi_1 = q_1 H(\tilde{f}) \delta(f), \quad \bar{\square}^2 \phi_2 = q_2 H(\tilde{f}) \delta'(f), \quad \bar{\square}^2 \phi_3 = q_3 \delta(f) \delta(\tilde{f})$$

i) Solution of  $\bar{\square}^2 \phi_1 = q_1 H(\tilde{f}) \delta(f)$  [Eq. (4.23b), NASA TP-3428]

$$4\pi\phi_1(\hat{x}, t) = \int \frac{q_1(\hat{y}, \tau)}{r} H(\tilde{f}) \delta(f) \delta(g) d\hat{y} d\tau$$

Let  $\tau \rightarrow g, \frac{\partial g}{\partial \tau} = 1$ , integrate with respect to  $g$

$$4\pi\phi_1(\hat{x}, t) = \int \frac{[q_1]_{\text{ret}}}{r} H(\tilde{F}) \delta(F) d\hat{y}$$

# Derivation of the Supersonic Kirchhoff Formula (Cont'd)

Here  $F(\dot{y}; \hat{x}, t) = [f(\dot{y}, \tau)]_{\text{ret}} = f(\dot{y}, t - r/c)$  and

$$\tilde{F}(\dot{y}; \hat{x}, t) = [\tilde{f}(\dot{y}, \tau)]_{\text{ret}} = \tilde{f}(\dot{y}, t - r/c)$$

We have treated integrals of this type before. We write the element of surface area of  $F = 0$  by  $d\Sigma$ . The  $\Sigma$ -surface was explained earlier.

$$4\pi\phi_1(\hat{x}, t) = \int_{\substack{F=0 \\ \tilde{F}>0}} \frac{[q_1]_{\text{ret}}}{r\Lambda} d\Sigma$$

$$\Lambda^2 = |\nabla F|^2 = 1 + M_n^2 - 2M_n \cos\theta$$

$$\cos\theta = \hat{n} \cdot \hat{x}$$



## Derivation of the Supersonic Kirchhoff Formula (Cont'd)

ii) Solution of  $\square^2 \phi_2 = q_2 H(\tilde{f}) \delta'(f)$  [Eq. (4.23e), NASA TP-3428]

$$4\pi\phi_2(\hat{x}, t) = \int \frac{q_2}{r} H(\tilde{f}) \delta'(f) \delta(g) d\hat{y} d\tau$$

Let  $\tau \rightarrow g$ ,  $\frac{\partial g}{\partial \tau} = 1$ , integrate with respect to  $g$

$$4\pi\phi_2(\hat{x}, t) = \int \frac{[q_2]_{\text{ret}}}{r} H(\tilde{F}) \delta'(F) d\hat{y}$$

The interpretation of integrals involving derivatives of delta functions was given before. Note that we get a line integral on  $F = \tilde{F} = 0$  because

$$\frac{\partial}{\partial N} H(\tilde{F}) = \hat{N} \cdot \nabla \tilde{F} \delta(\tilde{F})$$

# Derivation of the Supersonic Kirchhoff Formula (Cont'd)

$$4\pi\phi_2(\hat{x}, t) = \int_{\substack{F=0 \\ \tilde{F}>0}} \left\{ -\frac{1}{\Lambda} \frac{\partial}{\partial N} [q_2]_{\text{ret}} + \frac{2H_F [q_2]_{\text{ret}}}{r\Lambda^2} \right\} d\Sigma$$

$$- \int_{\substack{F=0 \\ \tilde{F}=0}} \frac{[q_2]_{\text{ret}} \cot\theta'}{r\Lambda^2} dL$$

$$\hat{N} = \frac{\nabla F}{|\nabla F|} = \frac{\hat{n} - M_\nu \hat{r}}{\Lambda}, \quad \tilde{N} = \frac{\nabla \tilde{F}}{|\nabla \tilde{F}|} = \frac{\hat{v} - M_\nu \hat{r}}{\tilde{\Lambda}}$$

$$\tilde{\Lambda}^2 = |\nabla \tilde{F}|^2 = 1 + M_\nu^2 - 2M_\nu \cos\tilde{\theta}, \quad \cos\tilde{\theta} = \hat{v} \cdot \hat{r}$$

$$\cos\theta' = \hat{N} \cdot \tilde{N}, \quad H_F \text{ mean curvature of } \Sigma\text{-surface}$$

## Derivation of the Supersonic Kirchhoff Formula (Cont'd)

iii) Solution of  $\square^2 \phi_3 = q_3 \delta(\tilde{f}) \delta(f)$  [Eq. (4.23f), NASA TP-3428]

$$\begin{aligned} 4\pi\phi_3(\hat{x}, t) &= \int \frac{q_3}{r} \delta(\tilde{f}) \delta(f) \delta(g) d\hat{y} d\tau \\ &= \int \frac{1}{r} [q_3]_{\text{ret}} \delta(\tilde{F}) \delta(F) d\hat{y} \end{aligned}$$

The interpretation of this integral was given before.

$$4\pi\phi_3(\hat{x}, t) = \int_{\substack{F=0 \\ \tilde{F}=0}} \frac{1}{r} \frac{[q_3]_{\text{ret}} dL}{\Lambda_0}$$

where  $\Lambda_0 = |\nabla F \times \nabla \tilde{F}| = \Lambda \tilde{\Lambda} \sin \theta'$ ,  $\cos \theta' = \hat{N} \cdot \hat{N}$

# Derivation of the Supersonic Kirchhoff Formula (Cont'd)

Now putting the solutions for  $\phi_1$ ,  $\phi_2$ , and  $\phi_3$  together in  $\tilde{\phi}$ , we get the supersonic Kirchhoff formula

$$4\pi\tilde{\phi}(\hat{x}, t) = \int_{\substack{F=0 \\ \tilde{F}>0}} \frac{1}{r\Lambda} \left[ Q_1 + \frac{2H_F}{\Lambda} Q_2 + \frac{\tilde{N} \cdot \nabla \Lambda}{\Lambda^2} Q_2 - \frac{\tilde{N} \cdot \nabla Q_2}{\Lambda} \right] d\Sigma$$

$$+ \int_{\substack{F=0 \\ \tilde{F}>0}} \frac{\tilde{N} \cdot \nabla r}{r^2 \Lambda^2} Q_2 d\Sigma + \int_{\substack{F=0 \\ \tilde{F}=0}} \frac{1}{r\Lambda_0} \left[ Q_3 - \frac{\tilde{\Lambda} \cos\theta'}{\Lambda} Q_2 \right] dL$$

where  $Q_i = [q_i]_{\text{ref}}, i = 1-3$

This equation was derived by Farassat and Myers in 1994. It was presented at ASME Int. Mech. Eng. Congress and Expo., Nov. 6-11, 1994, Chicago, Illinois. It was also published with improved derivation as a paper at the First Joint CEAS/AIAA Aeroacoustics Conference, June 12-15, 1995, Munich, Germany.

## The Mean Curvature $H_F$ of $\Sigma$ -Surface ( $f = 0$ Rigid)

$$H_F = -\frac{M_n}{r\Lambda} \left(1 - \frac{\sin^2\theta}{2\Lambda^2}\right) + \frac{(1-M_r)^2}{\Lambda^3} H_f + \frac{1-M_r}{\Lambda^3} (\hat{r}_t \cdot \hat{q} + \kappa_1 \tilde{\lambda}^1 \tilde{\gamma}^1 + \kappa_2 \tilde{\lambda}^2 \tilde{\gamma}^2) + \frac{\sin^2\theta}{2\Lambda^3} \left(\frac{1}{c} \dot{M}_n + M^2 \kappa_\gamma\right) + \frac{1}{\Lambda^3} (\hat{\gamma} \cdot \hat{q})(\hat{\lambda} \cdot \hat{r}_t)$$

$$\Lambda = (1 + M_n^2 - 2M_n \cos\theta)^{1/2}, \quad \cos\theta = \hat{n} \cdot \hat{r}, \quad \hat{r} = \frac{\hat{x} - \hat{y}}{r}, \quad M = |\vec{M}|,$$

$\hat{r}_t = \hat{r} - \hat{n} \cos\theta$ ,  $\vec{M}_t = \vec{M} - M_n \hat{n}$  ( $\hat{r}_t$  and  $\vec{M}_t$  are projections of  $\hat{r}$  and  $\vec{M}$  on local tangent plane to  $f=0$ ),  $\kappa_1$  and  $\kappa_2$  local principal curvatures of  $f=0$ ,  $\kappa_\gamma$  local normal curvature of  $f=0$  along  $\hat{\gamma}$ ,  $H_f$  local mean curvature of  $f=0$ ,

$$\hat{q} = \frac{1}{c} \hat{n} \times \hat{\omega}, \quad \hat{\omega} \text{ angular velocity}, \quad \hat{\gamma} = \hat{n} \times \hat{r}_t, \quad \hat{\lambda} = \hat{n} \times \vec{M}_t,$$

$\dot{M}_n = \hat{n} \cdot \dot{\vec{M}}$ ,  $(\tilde{\lambda}^1, \tilde{\lambda}^2)$  and  $(\tilde{\gamma}^1, \tilde{\gamma}^2)$  components of  $\hat{\lambda}$  and  $\hat{\gamma}$  in principal directions with respect to unit basis vectors, respectively.

# Selection of the Kirchhoff Surface for Supersonic Kirchhoff Formula

It can be shown that when the collapsing sphere leaves the Kirchhoff surface  $f = 0$  tangentially at a point where  $M_n = 1$ , the supersonic Kirchhoff formula will develop a singularity. One can solve this problem by selecting a biconvex shape for Kirchhoff surface avoiding the above singularity condition. In rotor noise calculations, in-plane noise of high speed rotors is the most important. Reasonable shape of Kirchhoff surface is possible. Farassat and Myers have shown that the singularity from line integral in Kirchhoff formula is integrable. (See paper in *Theoretical and Computational Acoustics*, vol. 1, D. Lee et al. (eds), 1994, World Scientific Publishing.)

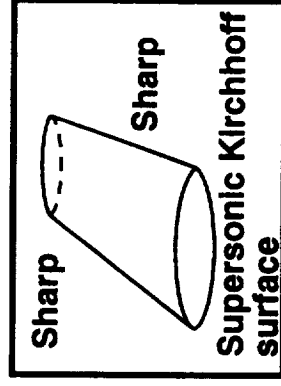

## References for Differential Geometry

Most of the results on differential geometry in previous pages were known by the end of the 19th century. The contribution of 20th century mathematicians has been development of general and powerful techniques to solve difficult problems but written in a supposedly rigorous style making differential geometry inaccessible to engineers. Here are a few useful books.

1. Dirk J. Struik: Lectures on Classical Differential Geometry, 2nd ed., Dover Books, 1988.
2. Erwin Kreyszig: Differential Geometry, Dover Books, 1991.
3. A. J. McConnell: Applications of Tensor Analysis, Dover Books, 1957.
4. R. Aris: Vectors, Tensors, and the Basic Equations of Fluid Mechanics, Dover Books, 1989.

## References for Generalized Functions

1. M. J. Lighthill: *Introduction to Fourier Analysis and Generalized Functions*, Camb. Univ. Press, 1964. (Generalized functions of one variable, sequential approach, excellent book!)
2. D. S. Jones: *The Theory of Generalized Functions*, 2nd ed., Camb. Univ. Press, 1982. (Multivariable generalized functions, sequential approach, highly technical, full of useful results.)
3. I. M. Gel'fand and G. E. Shilov: *Generalized Functions*, Vol. 1, *Properties and Operations*, Academic Press, 1964. (Probably the best book ever written on generalized functions, highly readable, full of useful results.)
4. R. P. Kanwal: *Generalized Functions—Theory and Technique*, Academic Press, 1983. (Highly readable but also advanced.)
5. R. S. Strichartz: *A Guide to Distribution Theory and Fourier Transforms*, CRC Press, 1994. (Masterful expository book.)
6. F. Farassat: *Introduction to Generalized Functions With Applications in Aerodynamics and Aeroacoustics*, NASA TP-3428, May 1994 (corrected April 1996). (The main reference for this workshop.)



## Acknowledgments

My work on Kirchhoff formulas has been in collaboration with Dr. M. K. Myers of the George Washington University (JIAFS). Our technical discussions have influenced and shaped my thinking on acoustic problems. I have benefited from discussions on applications of Kirchhoff formulas to rotating blade noise prediction with Dr. A. Lyrintzis of Purdue University, Dr. Lyle Long of Penn State and Dr. Roger Strawn of U.S. Army Aeroflightdynamics Directorate (ATCOM) at Ames Research Center. I am grateful to Drs. K. S. Brentner, M. K. Myers and H. L. Atkins for their editing comments on the style and clarity of presentation.

# REPORT DOCUMENTATION PAGE

*Form Approved*  
OMB No. 0704-0188

Public reporting burden for this collection of information is estimated to average 1 hour per response, including the time for reviewing instructions, searching existing data sources, gathering and maintaining the data needed, and completing and reviewing the collection of information. Send comments regarding this burden estimate or any other aspect of this collection of information, including suggestions for reducing this burden, to Washington Headquarters Services, Directorate for Information Operations and Reports, 1215 Jefferson Davis Highway, Suite 1204, Arlington, VA 22202-4302, and to the Office of Management and Budget, Paperwork Reduction Project (0704-0188), Washington, DC 20503.

<b>1. AGENCY USE ONLY (Leave blank)</b>		<b>2. REPORT DATE</b> September 1996	<b>3. REPORT TYPE AND DATES COVERED</b> Technical Memorandum	
<b>4. TITLE AND SUBTITLE</b> The Kirchhoff Formulas for Moving Surfaces in Aeroacoustics-The Subsonic and Supersonic Cases			<b>5. FUNDING NUMBERS</b> WU 538-03-12-01	
<b>6. AUTHOR(S)</b> F. Farassat				
<b>7. PERFORMING ORGANIZATION NAME(S) AND ADDRESS(ES)</b> NASA Langley Research Center Hampton, VA 23681-0001			<b>8. PERFORMING ORGANIZATION REPORT NUMBER</b>	
<b>9. SPONSORING / MONITORING AGENCY NAME(S) AND ADDRESS(ES)</b> National Aeronautics and Space Administration Washington, DC 20546-0001			<b>10. SPONSORING / MONITORING AGENCY REPORT NUMBER</b> NASA TM-110285	
<b>11. SUPPLEMENTARY NOTES</b>				
<b>12a. DISTRIBUTION / AVAILABILITY STATEMENT</b>  Unclassified - Unlimited Subject Category 71  Availability: NASA CASI, (301) 621-0390			<b>12b. DISTRIBUTION CODE</b>	
<b>13. ABSTRACT (Maximum 200 words)</b>  One of the active areas of computational aeroacoustics is the application of the Kirchhoff formulas to the problems of the rotating machinery noise predictions. The original Kirchhoff formula was derived for a stationary surface. In 1988, Farassat and Myers derived a Kirchhoff Formula obtained originally by Morgans using modern mathematics. These authors gave a formula particularly useful for applications in aeroacoustics. This formula is for a surface moving at subsonic speed. Later in 1995 these authors derived the Kirchhoff formula for a supersonically moving surface. This technical memorandum presents the viewgraphs of a day long workshop by the author on the derivation of the Kirchhoff formulas. All necessary background mathematics such as differential geometry and multidimensional generalized function theory are discussed in these viewgraphs. Abstraction is kept at minimum level here. These viewgraphs are also suitable for understanding the derivation and obtaining the solutions of the Flowcs Williams-Hawkings equation. In the first part of this memorandum, some introductory remarks are made on generalized functions, the derivation of the Kirchhoff formulas and the development and validation of Kirchhoff codes. Separate lists of references by Lyrintzis, Long, Strawn and their co-workers are given in this memorandum. This publication is aimed at graduate students, physicists and engineers who are in need of the understanding and applications of the Kirchhoff formulas in acoustics and electromagnetics.				
<b>14. SUBJECT TERMS</b> Aeroacoustics, Kirchhoff Formulas, Noise Prediction, Generalized Functions			<b>15. NUMBER OF PAGES</b> 112	
			<b>16. PRICE CODE</b> A06	
<b>17. SECURITY CLASSIFICATION OF REPORT</b> Unclassified	<b>18. SECURITY CLASSIFICATION OF THIS PAGE</b> Unclassified	<b>19. SECURITY CLASSIFICATION OF ABSTRACT</b> Unclassified	<b>20. LIMITATION OF ABSTRACT</b> Unlimited	