

NASA Technical Memorandum 107302

Propulsion Selection for 85kft Remotely Piloted Atmospheric Science Aircraft

David J. Bents, Ted Mockler, and Jaime Maldonado
*Lewis Research Center
Cleveland, Ohio*

Andrew Hahn
*Ames Research Center
Moffett Field, California*

John Cyrus
*Naval Air Warfare Center
Warminster, Pennsylvania*

Paul Schmitz
*Power Computing Solutions Inc.
Cleveland, Ohio*

Jim Harp and Joseph King
*ThermoMechanical Systems, Inc
Canoga Park, California*

Prepared for
AUVSI 96
sponsored by the Association for Unmanned Vehicle Systems
Orlando, Florida, July 16–19, 1996



National Aeronautics and
Space Administration

Trade names or manufacturers' names are used in this report for identification only. This usage does not constitute an official endorsement, either expressed or implied, by the National Aeronautics and Space Administration.

Propulsion Selection for 85kft Remotely Piloted Atmospheric Science Aircraft

by

David J. Bents, Ted Mockler, and Jaime Maldonado - NASA Lewis Research Center

Andrew Hahn - NASA Ames Research Center

John Cyrus - Naval Air Warfare Center (Warminster)

Paul Schmitz - Power Computing Solutions Inc.

Jim Harp and Joseph King - ThermoMechanical Systems, Inc.

In their quest to get a better understanding of how the atmosphere behaves, scientists are getting more and more of their information from air samples taken from high flying aircraft. Because of the increasing influence of man-made pollutants and their potential ultimate impact, there is urgent need to understand the detailed chemistry and dynamics. The highest priority is to get in situ measurements at altitudes above 73 kft to over 80 kft especially within 12 degrees of the Equator. The most useful information comes from relative correlations between the different concentrations of chemical species that are observed; this dictates that each sample be subject to several different simultaneous measurements (the sample must be analysed aboard the aircraft immediately while fresh). As a minimum soundings are required:

- a.) from the tropopause to a minimum of 83 kft
- b.) at latitudes including the both the tropics and mid latitudes.
- c.) several repetitions in a time scale that is short compared to the seasonal variations (i.e., about 1 month).

To obtain useful ensembles of concentrations the soundings must be taken at many specified locations in the upper atmosphere, at specific times dictated by science opportunity. While instrument settling times require the air platform to traverse maximum altitude for at least 30 minutes at the selected location (the minimum acceptable), more useful ensemble information is gained by traversing maximum altitude along the entire path from base to the selected location (this is preferred).

These science priorities have driven the requirements summarized in Table I for a new atmospheric science aircraft (1). The aircraft will be unmanned because:

- a.) the science mission now appears achievable by a remotely piloted aircraft
- b.) the extreme altitudes and distances over water are more hazardous to a pilot than the mission should warrant
- c.) the weight of pilot and associated life support equipment equals or exceeds the payload, to the extent that unmanned operation can reduce aircraft size, weight, and cost.

This new aircraft is a primary goal of NASA's Environmental Research Aircraft and Sensor Technology (ERAST) Program being carried out by NASA and four builders of high altitude unmanned aircraft (the ERAST Alliance).

As Table I indicates, unusual performance capability is needed for this aircraft. A payload capacity of several hundred lbs is needed to carry all the instruments (the 150 kg specification is not a nominal value but represents a minimum below which scientific utility is compromised), and it has to fly far enough to reach the location of interest from base (at least 1000 km range is needed, but more is better). Because of the limited opportunities that are available for atmospheric observations, the aircraft is expected to be able to fly at any time of the day during any season, from any developed airfield worldwide.

Table I Atmospheric Science Aircraft Requirements

<p>Mission Profile</p> <p>A: Minimum Acceptable B: Preferred</p>	
Mission Altitude	83,000 ft.
Operational Radius	1000 km
Payload Weight	150 kg
Payload Electrical Power	1.5 kW _e
Payload Thermal Control	1.5 kW _t @ 25 C
Payload Accommodation	Access to Undisturbed Free Stream
Endurance at Mission Altitude	A: minutes B: hours
Airspeed Range	$0.4 < M < 0.85$
Operational Constraints	Can operate in moderate turbulence. Operation in ambient air temperatures to -100 C.
Crosswind Capability	Takeoff & landing in moderate crosswinds (min. 15 knots)
Deployment	To remote base of operations at airfields worldwide

The vehicle must also be low cost so that it can be maintained and operated for the science community within today's budget limits. That means its systems should be based on industry-supported, current production, commercially available hardware to the maximum extent possible. New technology development must be limited to only the most critical components, relying mainly on adaptations of existing hardware transferred from other applications. No mean feat, since this aircraft is expected to routinely fly higher than any subsonic aircraft has previously flown in order to collect the data. A subsonic (not supersonic) aircraft is required because some of the most important chemical species sampled are so delicate that they are destroyed by the aerodynamic heating and shock associated with supersonic flight.

That presents a challenge -- while there are many aircraft available that fly slowly at low altitudes, and there are high performance aircraft that can fly over 80,000 ft at supersonic speeds (very high power is required but jet engines are capable) there are no aircraft presently available

that fly higher than about 73 kft subsonically. Because of Nature's exponential lapse of ambient density and pressure with altitude (as reflected in Fig.1) the dynamic pressure available to a subsonic aircraft at > 80 kft altitude is limited; there is not enough to sustain wing loadings beyond the range 15-25 psf. Unable to utilize shock waves to maintain wing loading, an aircraft designed for the atmospheric science mission must therefore be lightweight with wing loading more like a sailplane than a powered aircraft.

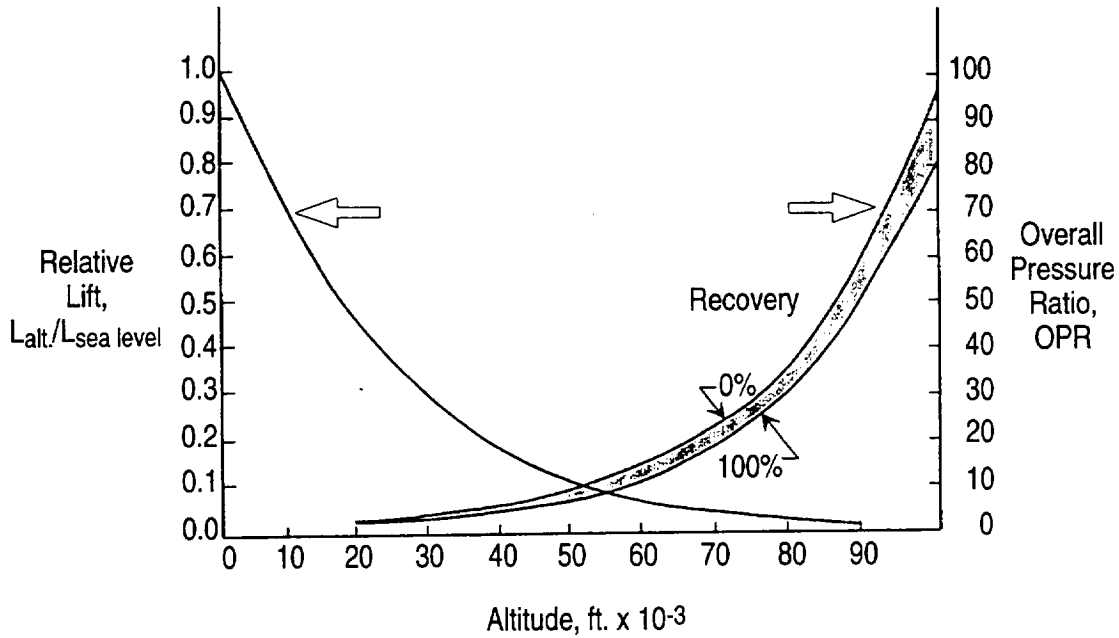

Fig. 1 Pressure Ratio needed for Flat-Rated Output Power
Relative Wing Lift and Altitude for Constant Flight Mach
Number of 0.50

The biggest challenge is propulsion--especially problematic since the cardinal rule for new aircraft success is to avoid propulsion development if at all possible. Because of the limited dynamic pressure available to a subsonic aircraft at > 80 kft, the relative lack of inlet pre-compression dictates that turbomachinery, not forward speed, must be employed to supply the intake pressurization required for air breathing engines.

The additional turbomachinery makes a heavy propulsion system. To operate at > 80 kft several stages of compression are required to ingest and compress the low density ambient air into useable combustion medium / working fluid. Half an atmosphere is typically required to sustain combustion in a turbine engine, while reciprocating engines need slightly over 1 atm to develop rated power. As Fig. 1 shows, the combustion air supply for either engine will need to sustain overall pressure ratios (OPR's) greater than 40 to 1 in order to develop rated power at 85 kft. Since power is proportional to mass flow, maintaining rated power at progressively higher altitudes translates to exponentially increasing flow volumes, and correspondingly enlarged capture areas as the OPR is increased. The weight growth is correspondingly nonlinear. Since the ingested air gets heated as it is compressed, raising OPR also generates additional heat loads which must be dealt with.

The density lapse also reduces heat transfer, which makes thermal rejection increasingly problematic with altitude. Any fixed size body (aircraft wing, inlet, compressor impeller, heat exchanger etc.) that traverses from sea level to 80 kft will experience a five fold decrease in Reynolds number (Re), while convective heat transfer drops more than ten fold. For powerplant heat exchangers this produces conflicting trends: more powerplant heat rejection as the compression heat load rises, versus the rapidly diminishing heat transfer available at higher altitudes. Fig. 2 shows how a typical aircraft engine coolant heat exchanger's weight and frontal area must increase in order to reject the same heat load compared to a sea level unit the calculation takes into account the colder air temperatures at altitude.

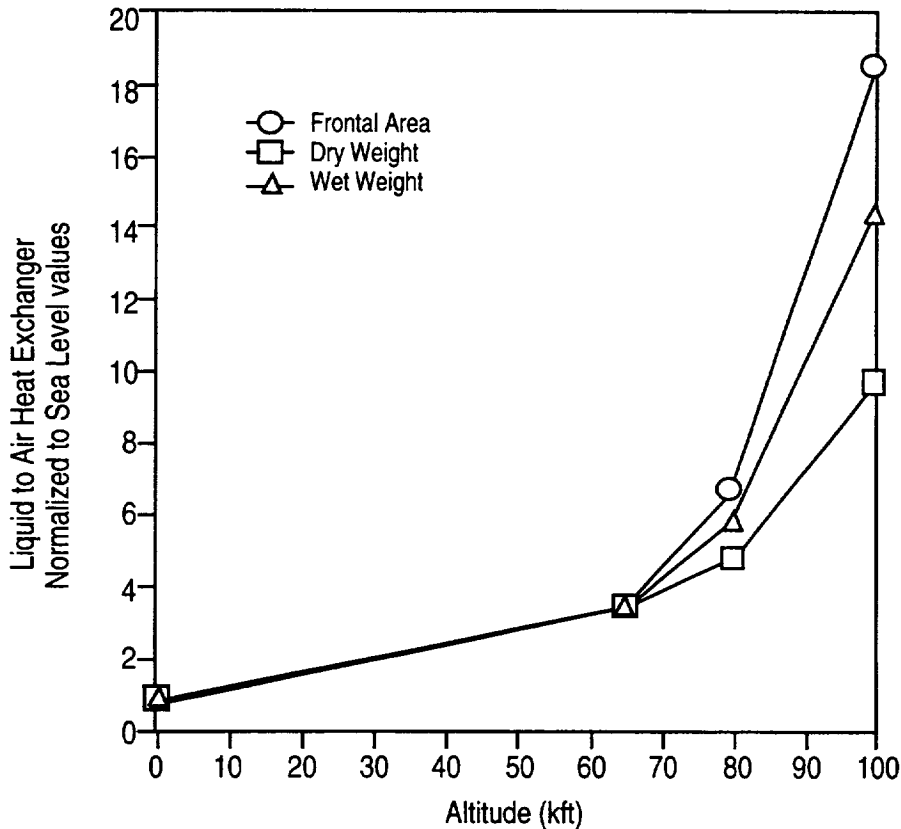

Fig. 2 Heat Exchanger Size Variation with Altitude

The net result is that, for subsonic flight, a high altitude propulsion unit is significantly larger and heavier for the same output compared to a low altitude unit. To complicate matters further, the high altitude aircraft needs to have a more powerful propulsion unit because it must go faster at altitude in order to support its own weight (maintain wing loading). As a result, the propulsion system will claim a greater fraction of the airplane's gross weight. This trend unfortunately runs counter to the airplane's ability to carry the weight.

Given these drawbacks, a non airbreathing propulsion system might be considered since it is not subject to the same limitations (no need to breathe and process ambient air). However, if it is combustion driven (such as rockets or expander engines) the airplane needs to carry oxidizer as well as fuel. The non airbreathing engine may not weigh very much but it consumes its

propellants in flight at a very rapid rate (oxidiser mass flow is typically four to five times fuel flow) so that propellant mass becomes a large fraction of aircraft weight, and flight duration will be limited compared to air breathing systems. As the propellants are consumed in flight, however, the aircraft will become progressively lighter, theoretically allowing higher altitudes than achievable with air breathing propulsion. The maximum altitude depends on the engine's specific propellant consumption, which must be low enough that the desired altitude is reached before all propellants are consumed. Studies carried out by NASA Ames in support of ERAST (1) showed that a specific propellant consumption less than 4.5 lb/HP-hr has to be realized in order for an RPA to fly a single excursion from sea level takeoff to 35 minutes at 80 kft. Fig. 3 compares the trajectories achievable for propulsion based on some hypothetical non-airbreathing expander engines versus the heavier but less thirsty airbreathing (turbocharged reciprocating engine) powerplant. Since known combustion expander engines have significantly higher consumption rates (6 - 12 lb/HP-hr), and since the atmospheric science mission needs duration and range beyond a single excursion, the

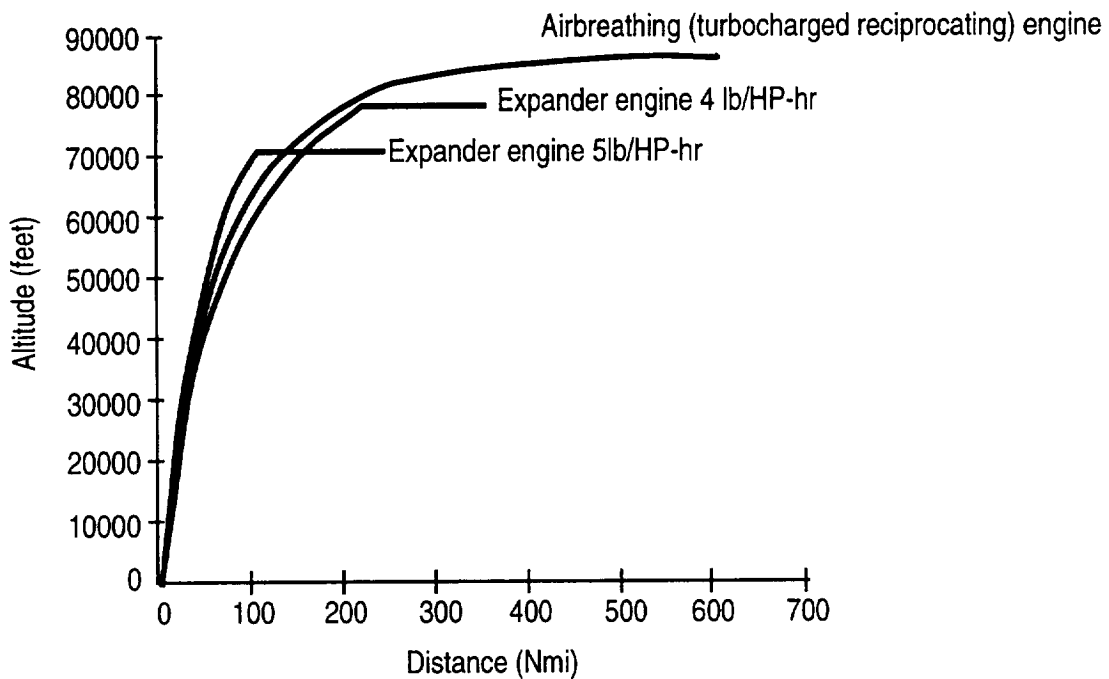

Fig. 3 Trajectories, Air Breathing vs. Non Air Breathing

combustion driven non airbreathing machine is precluded from further consideration (unless a specialized expander engine with lower spc were developed).

A non air-breathing system that does not consume propellant might be of interest. For example a solar electric aircraft has been shown capable of climbing to appreciable altitudes when its flight is timed to coincide with sunlight availability (the current record is 50 kft set by the Aerovironment Pathfinder in 1995; flights beyond 70 kft are presently anticipated for this aircraft (2)), and future developments in energy storage technology may herald an unlimited

duration flight depending on the location and time of year. However, the diurnal variation and diffuse nature of sunlight imposes restrictions on the latitude, season and time of day a solar aircraft can be flown and render it unable to carry appreciable payloads (the solar array only develops about ten useable watts per square ft of wing area) in an aircraft of reasonable physical size. Therefore the solar aircraft is not suited for this particular mission.

Because of the range and payload required for the atmospheric science mission, air breathing propulsion is still the logical choice. Mission studies conducted by Ames (1), supported by propulsion system studies at Lewis, have shown that a prototype aircraft constructed of modern structural materials and equipped with a high altitude specific OPR engine should be able to achieve 85 kft cruise altitude.

The most likely candidates for the ERAST aircraft were a.) turbine engines and b.) turbocharged reciprocating engines. At 85 kft the distinction between the two becomes somewhat blurred since the turbocharged IC could be considered as a specialized variant of a turbine engine whose combustor is replaced by an reciprocating engine core. It is of course the turbine engine which has in most cases surpassed the reciprocating engine and enabled present day high altitude flight performance to be achieved, including supersonic flight. Some turbine-powered aircraft (see Table II) have demonstrated subsonic flight that approaches the desired altitudes and one of

Table II Previous High Altitude Subsonic Aircraft

Aircraft Destination	Original Purpose (and year flown)	Altitude Record	Propulsion System Used	Science Platform Availability
WB-57	high altitude strategic bomber (1949)	65,876 ft. 8/29/55	Bristol "Olympus" turbojet	NCAR atmospheric science
ER-2	high altitude reconnaissance (1955)	73,200 ft. 8/4/95	GE-F118 turbofan	NASA atmospheric science
AQM91M Compass Arrow	high altitude reconnaissance (1969)	>81,000 ft. Sept. 1969	GE-J97-3 turbojet	military only, no longer exists
Grob Egrett	high altitude science aircraft (1988)	53,055 ft. 9/1/88	Garrett TPE331 turboprop	DoE atmospheric science
Boeing Condor	high altitude science reconnaissance (1989)	67,028 ft. 2/15/89	2 stage turbo-charged spark ignition engine	military only, no longer exists
Grob Strato 2C	atmospheric science (1995)	60,867 ft. 8/4/95	3 stage turbo-charged spark ignition engine	DLR (Germany) atmospheric science

them, the Viet Nam era AQM91 Compass Arrow spyplane, arguably demonstrated that capability more than 25 years ago (3). Powered by a special design turbojet engine (the General Electric J97, shown in Fig. 4), Compass Arrow could achieve > 80 kft flying at $M = 0.83$

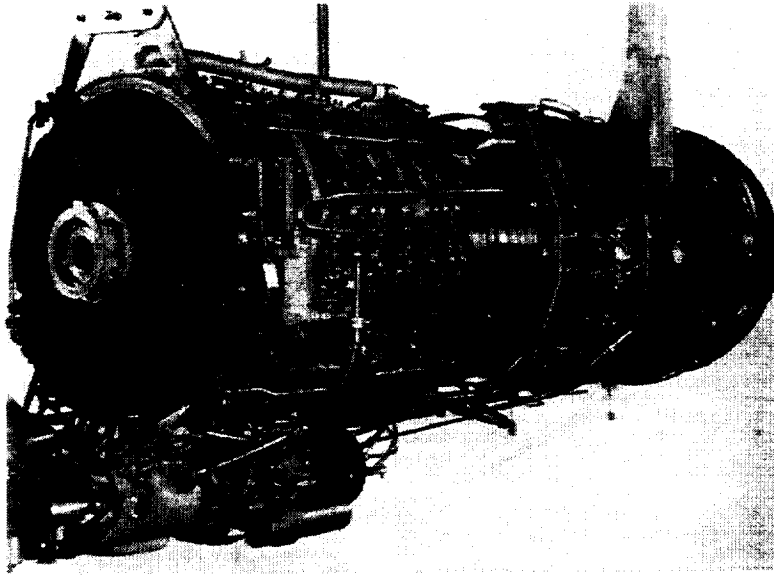

W_{aSL}	=	66.2 lbm/s
OPR_{SL}	=	11.5
$F_{nM=.83@80k}$	=	184 lbf
$SFC_{M=.83@80k}$	=	1.298
$Weight_{dry}$	=	694 lb

Fig. 4 General Electric J97 Turbojet

airspeed (the minimum speed giving enough inlet precompression to keep the combustor lit at that altitude). Proposals to develop a new variant of this aircraft using J97 hardware left over from the original Compass Arrow program have been considered by NASA. There remain twenty-four J97 pre-production prototype units (not fully qualified) which were surplused to NASA following the Air Force's decision not to pursue system acquisition; these are in storage at Ames Research Center.

The advantage of gas turbine power is that the high specific power (HP / lb) which it can develop allows high speeds and relatively high wing loading to be maintained, which reduces the aircraft's susceptibility to winds and turbulence at lower altitudes and makes for shorter flight times to conduct the mission. The disadvantages are higher fuel consumption (less range) and the exponential thrust lapse that occurs with altitude. As the air density drops the turbine engine will ingest correspondingly smaller amounts of air resulting in less power and less thrust; this eventually leads to combustor flameout. Fig. 5 (solid line) shows a power lapse curve typical of turbine engines illustrating this trend. As an example, the Compass Arrow's turbojet engine, capable of over 5,000 pounds of thrust at sea level, would produce only 184 pounds of thrust at 80,000 ft (Mach no. = 0.85) and would be operating on the verge of flameout.

It would be possible to design and develop a new jet engine specifically for higher altitudes (85,000 feet) using present day materials and turbine technology. It would need to incorporate a high pressure ratio compressor (25:1 to 35:1) and wide chord blades (to minimize Re effects), and probably a stabilized pilot flame combustor (perhaps using a secondary fuel such as hydrogen) to prevent flameout at high altitudes. The design would have more turbomachinery stages and larger flow area (wheel diameters) than the J97, resulting in a higher OPR, and some appreciable thrust, at 85,000 ft. However, as Fig. 5 also illustrates (dashed lines and shaded

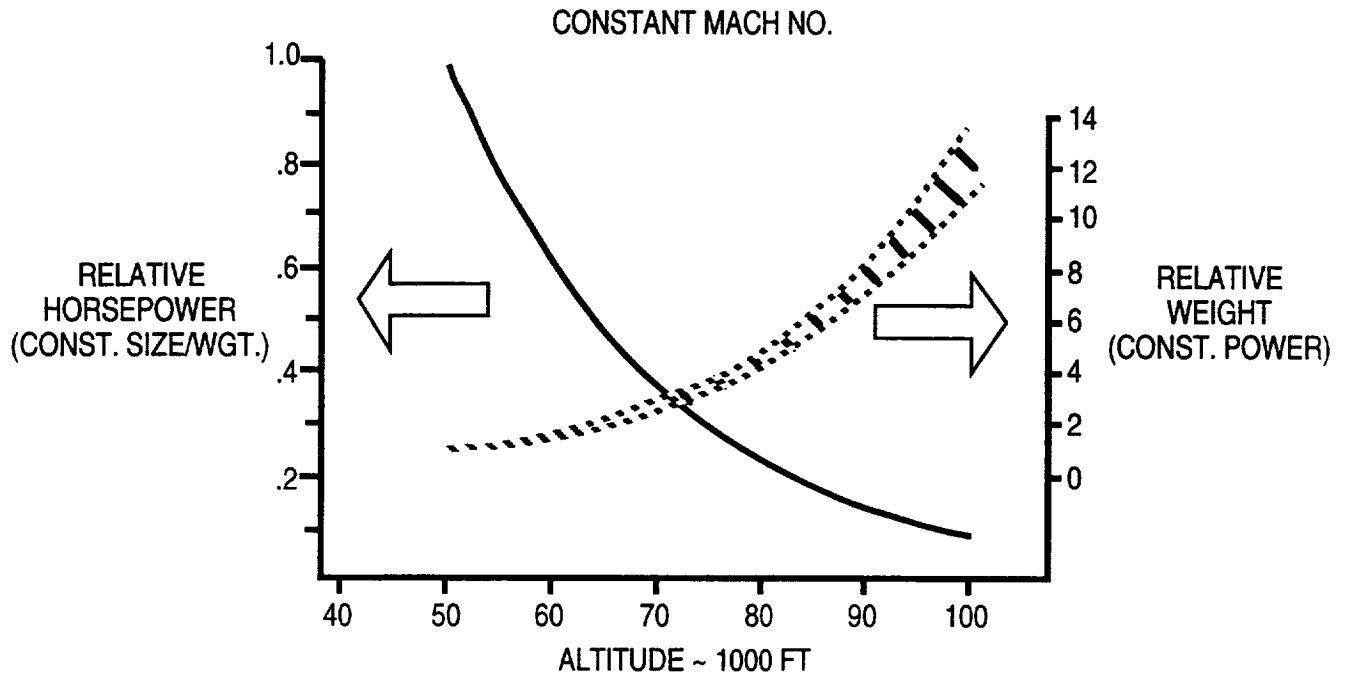

Fig. 5 Altitude Effect on Turbine Engine Power/Weight

region), this engine would be larger and heavier than the J97. Preliminary design of such a small turbojet, capable of subsonic flight up up to about 90 kft (Fig. 6), has been investigated.

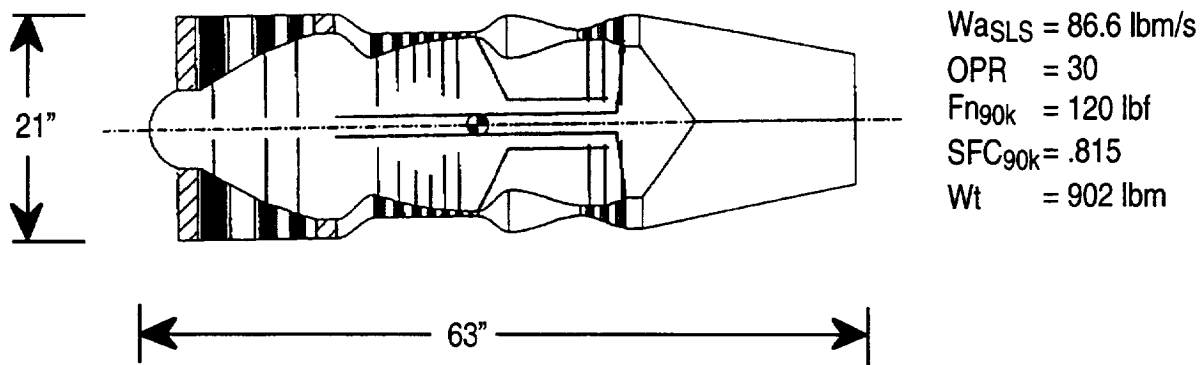

Fig. 6 Very High Altitude Turbojet Preliminary Design for ERAST

Development of this specialized design (or any new design for that matter) would be expensive (for example, the J97 engine cost approximately \$60M to develop during the mid 1960's; a sum roughly equivalent to \$300M today). Because of the costs, development of a new jet engine is usually not undertaken unless there is a large market anticipated. The atmospheric science aircraft market is tiny; therefore the only turbine engine available for ERAST would be a J97 unit rebuilt from the remaining inventory of prototype hardware that never became a manufacturer-supported product.

The other alternative is a propeller driven unit powered by a turbocharged reciprocating engine.

These have long been considered attractive power plants for subsonic flight at high altitudes. As Fig. 7 illustrates, a propeller provides high propulsive efficiency because of its large capture area, which in turn enables high altitude flight at slower airspeeds and reduced fuel consumption. A diagram of the three stage system characterized for ERAST is shown in Fig. 8. Because there

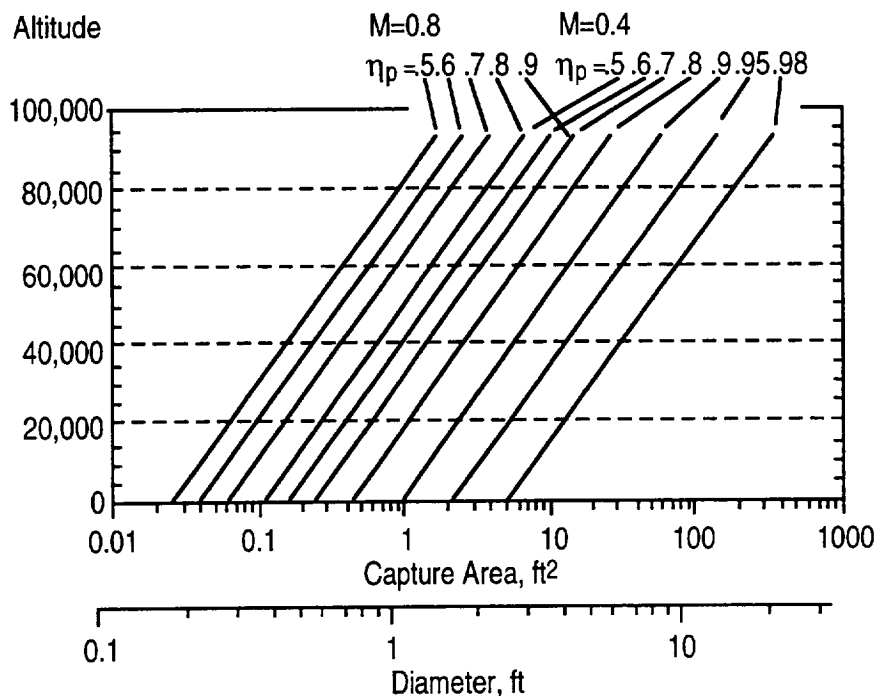

Fig. 7 Approximate Capture Area and Diameter Required for 100 lbf Thrust vs. Altitude, Airspeed and Desired Propulsive Efficiency

is an existing technology base of mass-produced automotive and general aviation hardware that can be adapted for this purpose, it is possible to develop a turbocharged power plant with its core engine and turbocharger/intercooler system at much lower cost than a jet engine. Several multiple stage turbo/supercharging systems have already been demonstrated either in high altitude flight or in altitude test chambers. Table III provides a summary of the test and flight capabilities and accomplishments of these systems to date.

The reciprocating engine type that develops the most horsepower for the least weight at 80 kft is the "old fashioned" spark ignited gasoline engine, with multiple stages of turbocharging to pressurize the intake manifold to sea level values. What gives the gasoline engine its edge is that, of all internal combustion engines, it burns a nearly stoichiometric fuel air mixture; that is, it actually burns most of the air it ingests. Fig. 9 illustrates the impact of specific air consumption on turbomachinery sizing. Because stoichiometric combustion minimizes specific air consumption, spark ignition engines require smaller turbomachinery to pressurize the core engine's induction air than diesel engines of equivalent shaft power, and significantly smaller size than gas turbine engines. The spark ignited engine's exhaust gases are

Table III Turbocharged Reciprocating Engines

	Developer	Core Engine Used	No. of Stages/ Turbo Mf'r.	Rated HP Demo @ Rated Alt.	Highest Recorded Ground Test Performance	Highest Altitude Achieved in Flight
TEAL RAIN	Thermo Mechanical Systems (TMS)	3 Cylinder Drake 36.6 cid	3 Stages/ TMS	70 HP @ 65 kft Feb. 1982	47 HP @ 90 kft Mar. 1982	Ground demo only
Condor	Boeing Teledyne Continental Motors	6 Cylinder Continental 350 cid	2 Stages/ Teledyne Continental	182 HP @ 67 kft Feb. 1989	data not available	67,028 ft. Feb. 1989
Strato 2C	Grob/IABG/DLR	6 Cylinder Continental 550 cid	3 Stages/ IABG/P+W/ Garrett	400 HP @ 78 kft Dec. 1994	308 HP @ 82 kft Apr. 1995	60, 876 ft. Aug. 1995
Raptor D2	Scaled Composites/TMS	4 Cylinder ROTAX 74 cid	2 Stages/ TMS	103 HP @ 54 kft Jan. 1996	47 HP @ 70 kft Jan. 1996	Not flown yet
Perseus B/ Theseus	Aurora Flight Sciences	4 Cylinder ROTAX 74 cid	3 Stages/ Garrett	73 HP @ 59 kft May 1994	73 HP @ 59 kft May 1994	20,000 ft. Mar 1996
Altus	G. A. Aero/TMS	4 Cylinder ROTAX 74 cid	2 Stages/ TMS	103 HP @ 54 kft Jan. 1996	47 HP @ 70 kft Jan. 1996	Not flown yet

also hot enough (1400 - 1500°F) to have enough enthalpy to provide the turbocharger compressor work required for intake pressurization. As altitude increases and ambient pressure decreases, the increasing pressure ratio across the turbocharger turbines increases enthalpy extraction, roughly balancing the increased compressor loading.

Although the induction air flow for this engine is low, intercoolers must be used between compressor stages to remove the heat of compression (otherwise the engine would detonate). Heat rejection is complicated by the need to cool both core engine and intercoolers which must be coupled into the air stream. On a per horsepower basis the overall airflow is roughly equivalent to that of a gas turbine, but only the induction air (a tiny fraction) is compressed. The rest passes directly through the heat exchangers.

The turbocharged propeller powerplant is more complicated than a jet. In addition to the reciprocating core engine and turbocharger units, it has an air induction and exhaust system, thermal management systems (with associated radiators, fluid hoses and couplings to reject heat from the engine, one or two intercoolers and an aftercooler), an outside air inlet/duct system with controlled exit doors to provide cooling air for the thermal management system, a drivetrain subsystem consisting of a multi-speed gear box and variable pitch variable speed propeller, and a coordinated propeller, throttle and waste gate control that matches propeller loads, engine demand and turbocharger air supply. Operational reliability of a system consisting of so many interconnected elements is a significant issue. Historically, turbocharged piston aero engines have

required regular maintenance over operating intervals measured in tens of hours, and complete overhauls after hundreds of hours. This contrasts with modern turbine engines, where maintenance is performed after hundreds of hours operation, and thousands of hours between overhauls.

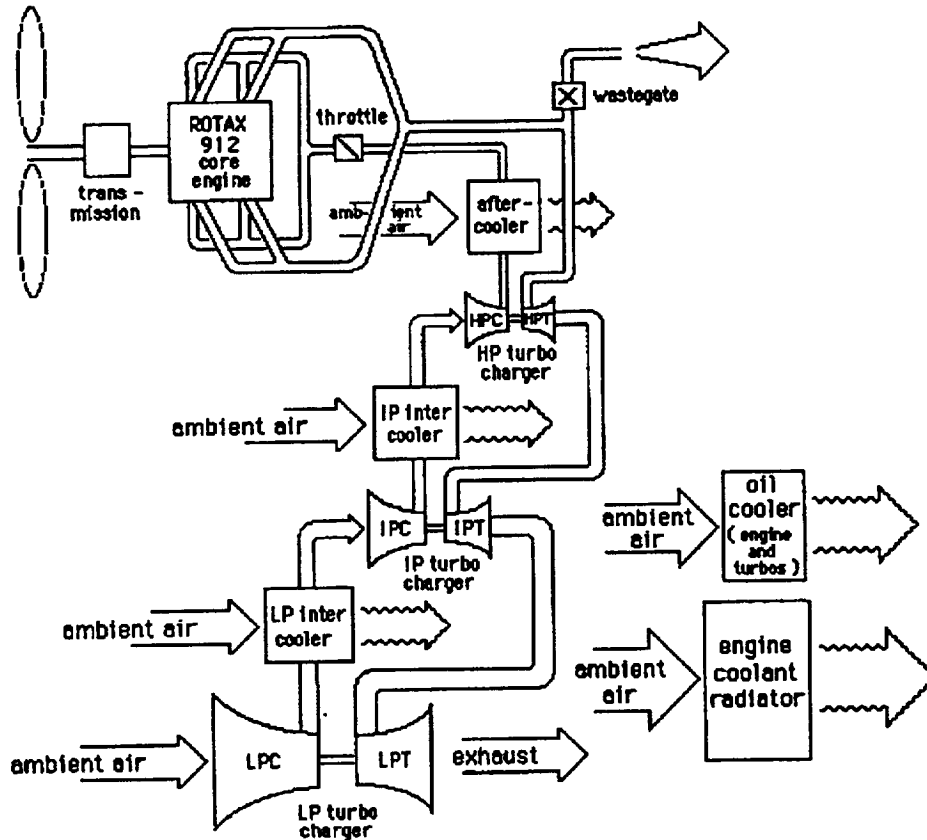

Fig. 8 Three Stage Turbocharged Powerplant for ERAST

Nevertheless the fundamental powerplant weight and performance trends discussed previously favor the turbocharged propeller unit. This can best be illustrated by comparing selected propulsion unit designs at 80 and 90 kft altitude, and considering the propulsion unit's weight (including drivetrains, propellers and heat exchangers), its delivered thrust in the flight regime indicated (chosen to best advantage for each type), and the thrust specific fuel consumption (TSFC) that results. The comparison presented in Table IV includes in addition to the small turbojet and turbocharged piston engine design concepts which were characterized for ERAST, data for both the J97 and the German Strato 2C's turbocharged powerplant (4,5), which was successfully demonstrated to 85 kft in an altitude chamber. The data show that while a turbocharged propeller unit will be slightly heavier on a per lb of thrust basis than a turbojet at 80 kft, its TSFC will be less. If the comparison is repeated at 90 kft, however, the turbocharged unit enjoys both better specific weight and better TSFC.

Table IV Turbojets vs. Turbocharged Ic Engine

Powerplant/Propulsion System (inlet recovery = 1.0)	Uninstalled Weight Including Propeller	Delivered Thrust	Specific Weight	Specific Consumption
@ 80 kft				
J97 turbojet @ M = 0.83	715 lbm	184 lbf	3.9 lbm/lbf	1.3 lbm/hr per lbf
J97 turbojet @ M = 0.8	715 lbm	Flameout	---	---
New turbojet @ 0.5<M<0.85	920 lbm	190 lbf	4.8 lbm/lbf	0.8 lbm/hr per lbf
Strato 2C (3 stage TCSI) @M=0.5	2457 lbm	360 lbf	6.8 lbm/lbf	0.44 lbm/hr per lbf
80K ERAST 3 stage TCSI @M=0.4	587 lbm	91 lbf	6.5 lbm/lbf	0.44 lbm/hr per lbf
@ 90 kft				
New turbojet @ 0.5< M < 0.85	920 lbm	120 lbf	7.7 lbm/lbf	0.8 lbm/hr per lbf
90K ERAST 3stage TCSI @M=0.4	667 lbm	90 lbf	7.4 lbm/lbf	0.44 lbm/hr per lbf

Although the turbocharged engine may exceed a gas turbine's altitude potential in low speed flight, its service ceiling in an aircraft is still ultimately limited by the increased size and weight of the (ever more complicated) turbomachinery and heat exchangers (weight, frontal area and drag) required to maintain performance at altitude. Fig. 10 shows the overall weight trends that result for turbocharged spark ignited powerplants. Weight growth is nonlinear - at altitudes approaching 90 kft the power plant will be too heavy to be carried by the wing loading available (the no fly zone.)

In 1996 the ERAST Alliance began a process to define the prototype of a remotely piloted science aircraft which will flight demonstrate the science mission capability summarized in Table I. This aircraft, known as HADur (for High Altitude Duration), will be propeller driven powered by turbocharged spark ignited engines. The Alliance selected this form of propulsion because:

- a.) the Ames and Lewis mission / propulsion studies indicated a propeller driven aircraft powered by turbocharged spark ignited engines can meet the Table I requirements, and may be able to achieve slightly higher cruise altitudes than other candidates.
- b.) most of the industry partners' experience is with this form of propulsion
- c.) a mission specific propulsion unit could be developed within the time and budget constraints of ERAST.

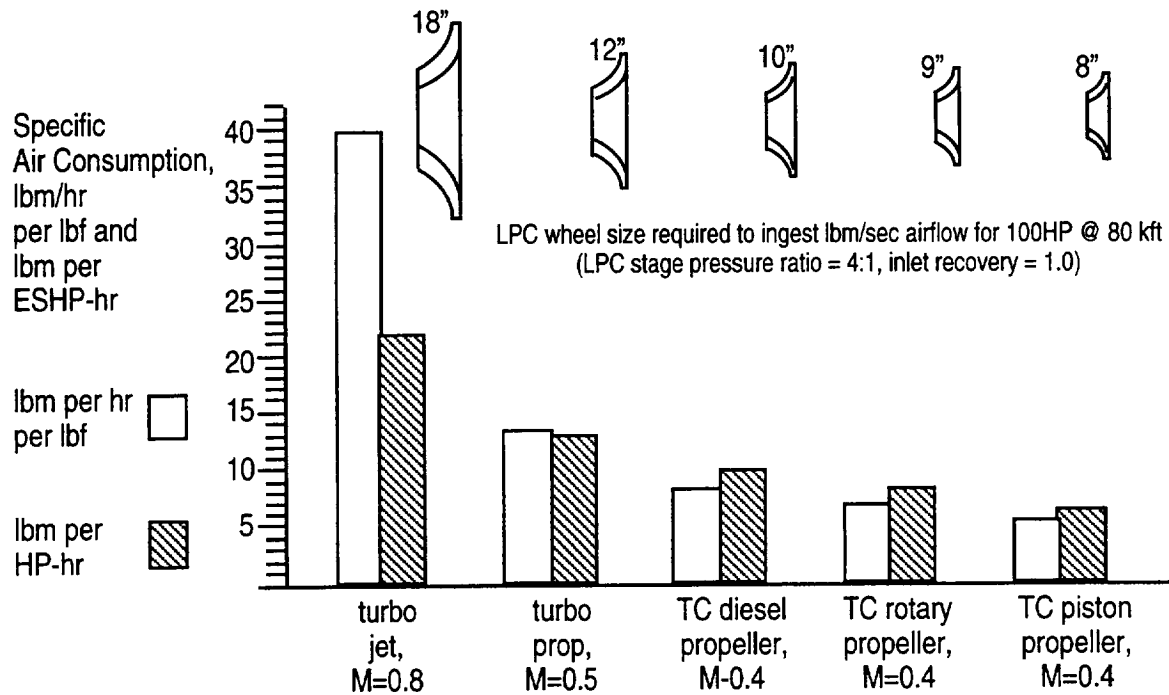

Fig. 9 Specific Air Consumption Dictates Turbomachinery Size

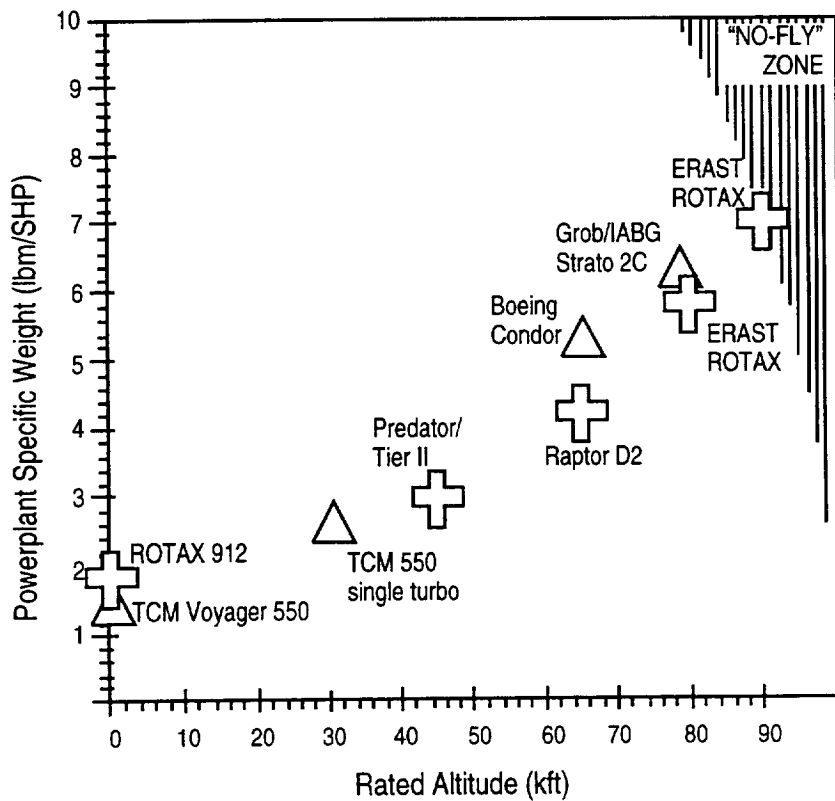

Fig. 10 Turbocharged Powerplant Specific Weight vs. Rated Altitude

Since no other user community has requirements equivalent to the atmospheric science needs, the

>80 kft subsonic propulsion capability will have to be developed entirely within NASA's limited resources. Fortunately there is a technology base of commercially available hardware for the turbocharged propeller powerplant, and the most critical components have recent hardware heritage that can be directly utilized.

Present development is focussed on a three stage turbocharged powerplant using the four cylinder ROTAX 912 engine core. This low cost aero engine is in current production, has factory technical support available, and due to the excellent reputation for durability it has already developed, enjoys widespread use among RPA and experimental "homebuilt" aircraft builders. The three stage turbocharger system is being developed by ThermoMechanical Systems (TMS) of Canoga Park CA, a small company with considerable previous background in turbocharger development and engine installations.

It was TMS who, under the formerly classified TEAL RAIN RPA technology development program that preceeded Condor in the early 1980's, successfully demonstrated operation of a three stage turbocharged (45 cid 3 cylinder) experimental engine producing 55 HP at 90 kft simulated altitude in a dynamometer equipped mechanically exhausted chamber (6). TMS later applied the intermediate pressure and high pressure stage hardware from TEAL RAIN to a ROTAX 912 core engine for demonstration of a two stage turbocharged engine for small high altitude long endurance (HALE) vehicles under the Ballistic Missile Defense Organization's RAPTOR program (an effort to develop HALE RPA's for launch detection of land mobile missiles; the Raptor aircraft and TMS hardware were transferred to NASA's ERAST program in 1995 as BMDO attention was shifted away from airborne surveillance systems to terminal defense). Further development eventually resulted in the two stage system producing 100 HP at 54 kft lapsing to 62 HP at 70 kft in the dynamometer altitude chamber.

TMS is now extending the Raptor engine to higher altitudes by adding the original TEAL RAIN low pressure stage, suitably modified to accommodate the ROTAX core engine's airflow requirements. TMS is now integrating the core engine and three turbochargers with the intent of producing, in the TMS chamber, a demonstration of at least 80 HP at 80 kft, a performance goal that directly addresses the science aircraft propulsion requirements. Fig. 11 is a photograph of the test article.

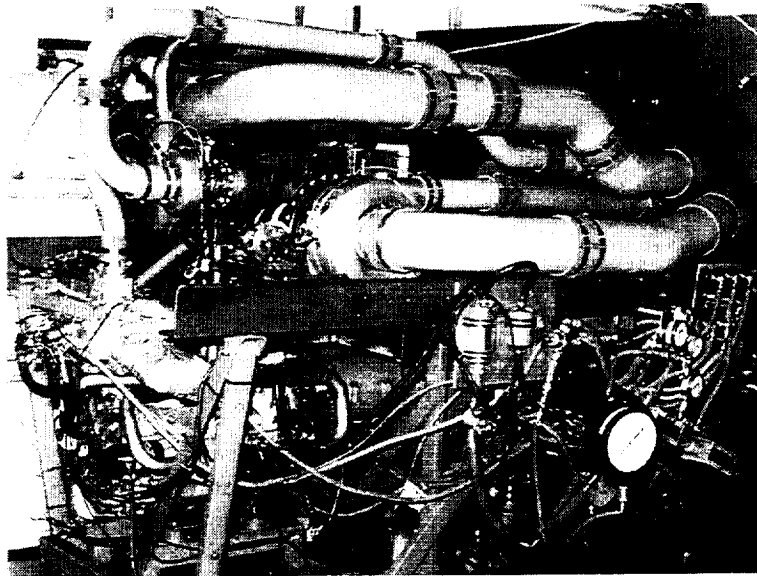

Fig. 11 Three Stage Turbocharged ROTAX 912 in TMS Chamber

This demonstration will be an important milestone but will not immediately result in a high altitude flight since the test article is a breadboard demonstration of critical hardware not the entire propulsion unit which has yet to be developed. Work that remains includes the balance of plant (inlets, exits, and ducts, heat exchangers, automatic controls etc.) and propeller/drivetrain development. Some of this work is already underway. High altitude low Reynolds number air cooled heat exchangers are presently being researched by NASA Lewis and a consortium of five heat exchanger manufactures led by the Ohio State University Research Foundation. Nacelle and inlet aerodynamics are being researched by groups at NASA and Old Dominion University. Definition of the 80 kft propeller has also begun between NASA and the Alliance partners. Drivetrain and propeller development is considered a unique challenge since at altitude the propeller operates in a low Rn high tip Mach no. regime. In traversing the altitudes from sea level to >80 kft it will, in spite of variable pitch, be subject to speed variations greater than 2 x -- as a result there will most likely be a multiple ratio reduction drive from the powerplant.

After all this propulsion hardware has been developed and ground tested to ensure it "works as advertised" it will be eventually integrated into the HADur airframe design leading to the ultimate objective of the ERAST propulsion development: flight demonstration of science mission capability.

REFERENCES

1. Report of the Environmental Research Aircraft and Sensor Technology (ERAST) Program Leadership Team, "A Review of Remotely Piloted Aircraft (RPA) Technology Required for High Altitude Civil Science Missions", National Aeronautics and Space Administration, Washington DC March 1996
2. M. Dornheim, "Solar Powered Aircraft Exceeds 50,000 Ft.", Aviation Week and Space Technology, Sept. 18, 1995

3. W. Wagner and W. Sloan, "Fireflies and Other UAV's", Teledyne Ryan Aeronautical Co. San Diego CA, June 1993
4. H. Tonksotter "The Strato 2C Propulsion System; A Low Cost Approach for a High Altitude Long Endurance Aircraft", Industrieranlagen-Betriebsgesellschaft mbH, March 1994
5. Anon, "STRATO 2C Technical Description" Deutsche Forschungsanstalt für Luft und Raumfahrt (DLR), November 1993
6. J. Harp, "Turbocharger System Development and Propulsion System Testing", TMS Report No. SR-36, prepared for Developmental Sciences Inc. under Contract No. DSI-80-TR-SC-05-A, ThermoMechanical Systems, Canoga Park CA May 1982 (declassified Mar 1994)

REPORT DOCUMENTATION PAGE

Form Approved
OMB No. 0704-0188

Public reporting burden for this collection of information is estimated to average 1 hour per response, including the time for reviewing instructions, searching existing data sources, gathering and maintaining the data needed, and completing and reviewing the collection of information. Send comments regarding this burden estimate or any other aspect of this collection of information, including suggestions for reducing this burden, to Washington Headquarters Services, Directorate for Information Operations and Reports, 1215 Jefferson Davis Highway, Suite 1204, Arlington, VA 22202-4302, and to the Office of Management and Budget, Paperwork Reduction Project (0704-0188), Washington, DC 20503.

1. AGENCY USE ONLY (Leave blank)	2. REPORT DATE October 1996	3. REPORT TYPE AND DATES COVERED Technical Memorandum	
4. TITLE AND SUBTITLE Propulsion Selection for 85kft Remotely Piloted Atmospheric Science Aircraft		5. FUNDING NUMBERS WU-537-10-20	
6. AUTHOR(S) David J. Bents, Ted Mockler, Jaime Maldonado, Andrew Hahn, John Cyrus, Paul Schmitz, Jim Harp, and Joseph King			
7. PERFORMING ORGANIZATION NAME(S) AND ADDRESS(ES) National Aeronautics and Space Administration Lewis Research Center Cleveland, Ohio 44135-3191		8. PERFORMING ORGANIZATION REPORT NUMBER E-10390	
9. SPONSORING/MONITORING AGENCY NAME(S) AND ADDRESS(ES) National Aeronautics and Space Administration Washington, D.C. 20546-0001		10. SPONSORING/MONITORING AGENCY REPORT NUMBER NASA TM-107302	
11. SUPPLEMENTARY NOTES Prepared for AUVSI 96 sponsored by the Association for Unmanned Vehicle Systems, Orlando, Florida, July 16-19, 1996. David J. Bents, Ted Mockler, and Jaime Maldonado, NASA Lewis Research Center; Andrew Hahn, NASA Ames Research Center, Moffett Field, California 94035; John Cyrus, Naval Air Warfare Center, Warminster, Pennsylvania 18974-0591; Paul Schmitz, Power Computing Solutions Inc., Cleveland, Ohio 44111; Jim Harp and Joseph King, ThermoMechanical Systems Inc., Canoga Park, California 91303. Responsible person, David J. Bents, organization code 5440, (216) 433-6135.			
12a. DISTRIBUTION/AVAILABILITY STATEMENT Unclassified - Unlimited Subject Category 07 This publication is available from the NASA Center for AeroSpace Information, (301) 621-0390.		12b. DISTRIBUTION CODE	
13. ABSTRACT (Maximum 200 words) This paper describes how a 3 stage turbocharged gasoline engine was selected to power NASA 's atmospheric science unmanned aircraft now under development. The airplane, whose purpose is to fly sampling instruments through targeted regions of the upper atmosphere at the exact location and time (season, time of day) where the most interesting chemistry is taking place, must have a round trip range exceeding 1000 km, carry a payload of about 500 lb to altitudes exceeding 80 kft over the site, and be able to remain above that altitude for at least 30 minutes before returning to base. This is a subsonic aircraft (the aerodynamic heating and shock associated with supersonic flight could easily destroy the chemical species that are being sampled) and it must be constructed so it will operate out of small airfields at primitive remote sites worldwide, under varying climate and weather conditions. Finally it must be low cost, since less than \$50 M is available for its development. These requirements put severe constraints on the aircraft design (for example, wing loading in the vicinity of 10 psf) and have in turn limited the propulsion choices to already-existing hardware, or limited adaptations of existing hardware. The only candidate that could emerge under these circumstances was a propeller driven aircraft powered by spark ignited (SI) gasoline engines, whose intake pressurization is accomplished by multiple stages of turbocharging and intercooling. Fortunately the turbocharged SI powerplant, owing to its rich automotive heritage and earlier intensive aero powerplant development during WWII, enjoys in addition to its potentially low development costs some subtle physical advantages (arising from its near-stoichiometric combustion) that may make it smaller and lighter than either a turbine engine or a diesel for these altitudes. Just as fortunately, the NASA/industry team developing this aircraft includes the same people who built multi-stage turbocharged SI powerplants for unmanned military spyplanes in the early 1980's. Now adapting hardware developed for reconnaissance at 65-70 kft to the interests of atmospheric science at 80-90 kft, their efforts should yield an aero powerplant that pushes the altitude limits of subsonic air breathing propulsion.			
14. SUBJECT TERMS High altitude; Subsonic aircraft; Aeropropulsion; Atmospheric science		15. NUMBER OF PAGES 18	
		16. PRICE CODE A03	
17. SECURITY CLASSIFICATION OF REPORT Unclassified	18. SECURITY CLASSIFICATION OF THIS PAGE Unclassified	19. SECURITY CLASSIFICATION OF ABSTRACT Unclassified	20. LIMITATION OF ABSTRACT