

013276

NASA Case No. LEW-16,231-1

Print Figure 1

No. Of Pages in Claims 44

No. Of Pages in Abstract 1

NOTICE

The invention disclosed in this document resulted from research in aeronautical and space activities performed under programs of the National Aeronautics and Space Administration. The invention is owned by NASA and is, therefore, available for licensing in accordance with the NASA Patent Licensing Regulation (14 Code of Federal Regulations 1245.2).

To encourage commercial utilization of NASA-owned inventions, it is NASA policy to grant licenses to commercial concerns. Although NASA encourages non-exclusive licensing to promote competition and achieve the widest possible utilization, NASA will consider the granting of a limited exclusive license, pursuant to the NASA Patent Licensing Regulations, when such a license will provide the necessary incentive to the licensee to achieve early practical application of the invention.

Address inquiries and all applications for license for this invention to NASA Lewis Research Center, Patent Counsel, Mail Code Le-LAW, 21000 Brookpark Road, Cleveland, OH 44135-3195. Approved NASA forms for application for non-exclusive or exclusive license are available from the above address.

Serial Number 08/739,342

Filing Date October 17, 1996

NASA/LeRC

(

ABSTRACT OF THE DISCLOSURE

5 A resilient braided rope seal for use in high temperature applications. The resilient braided rope seal includes a center core of fibers, a resilient member overbraided by at least one layer of braided sheath fibers tightly packed together. The resilient member adds significant stiffness to the seal while maintaining resiliency. Furthermore, the seal permanent set and hysteresis are greatly reduced. Finally, improved load capabilities are provided.

Resilient Braided Rope Seal
08/739,342
Bruce M. Steinetz
Lawrence A. Kren
NASA Lewis Research Center

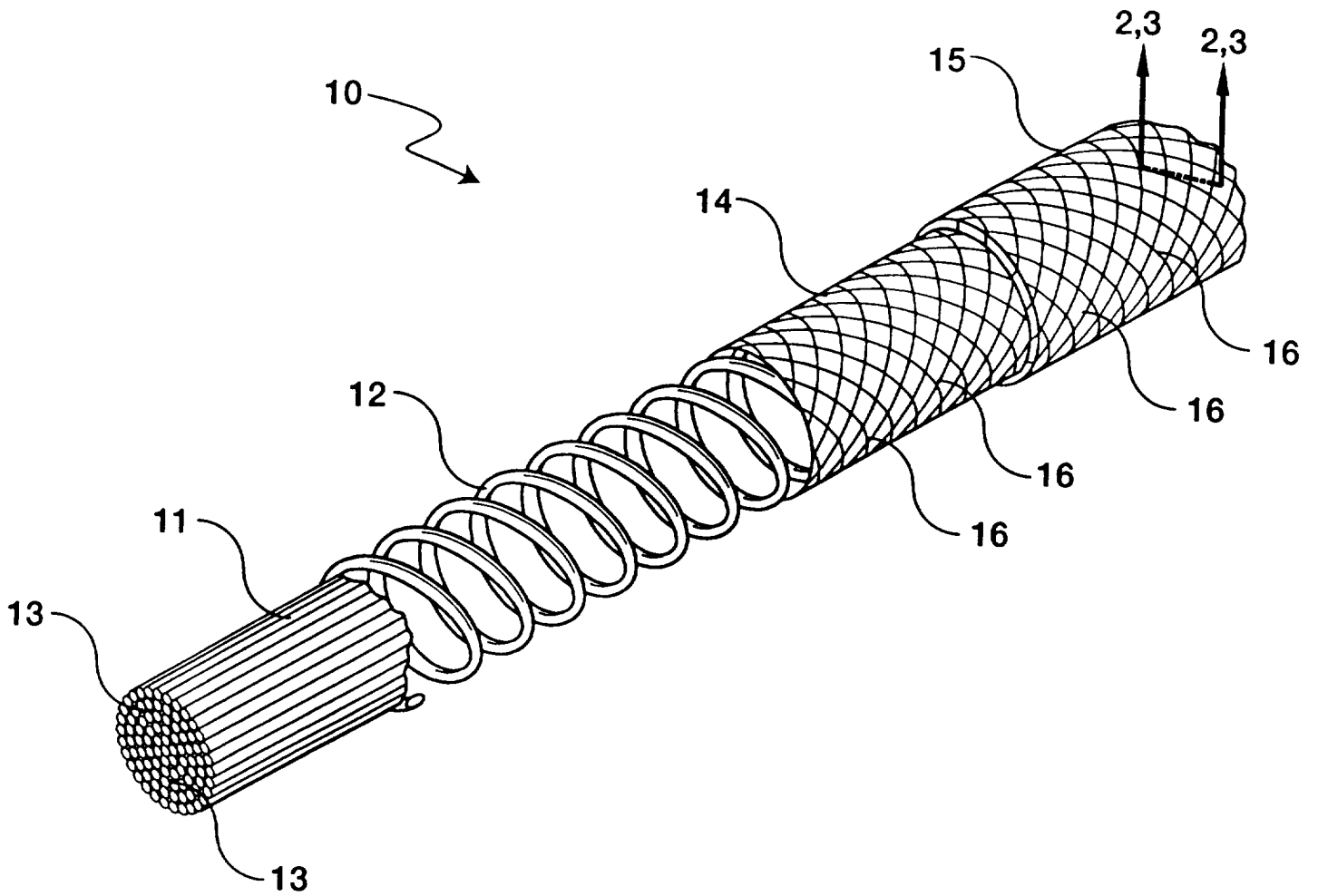

FIG. 1

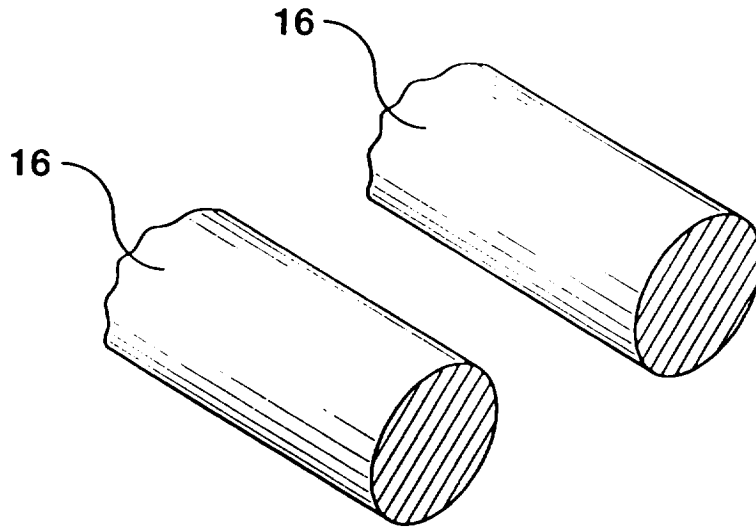

FIG. 2

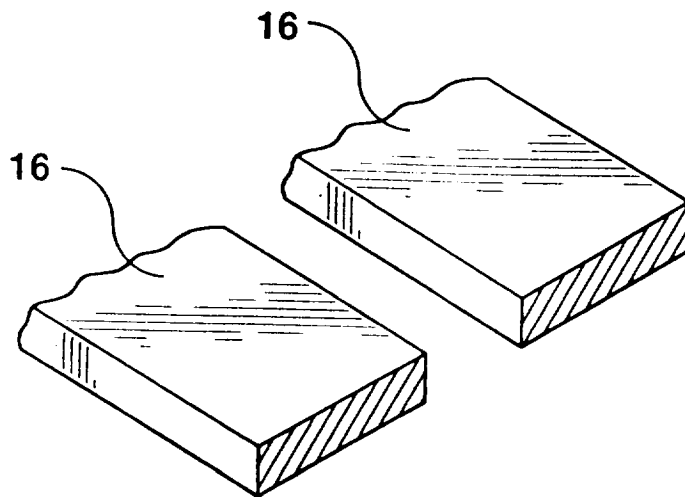

FIG. 3

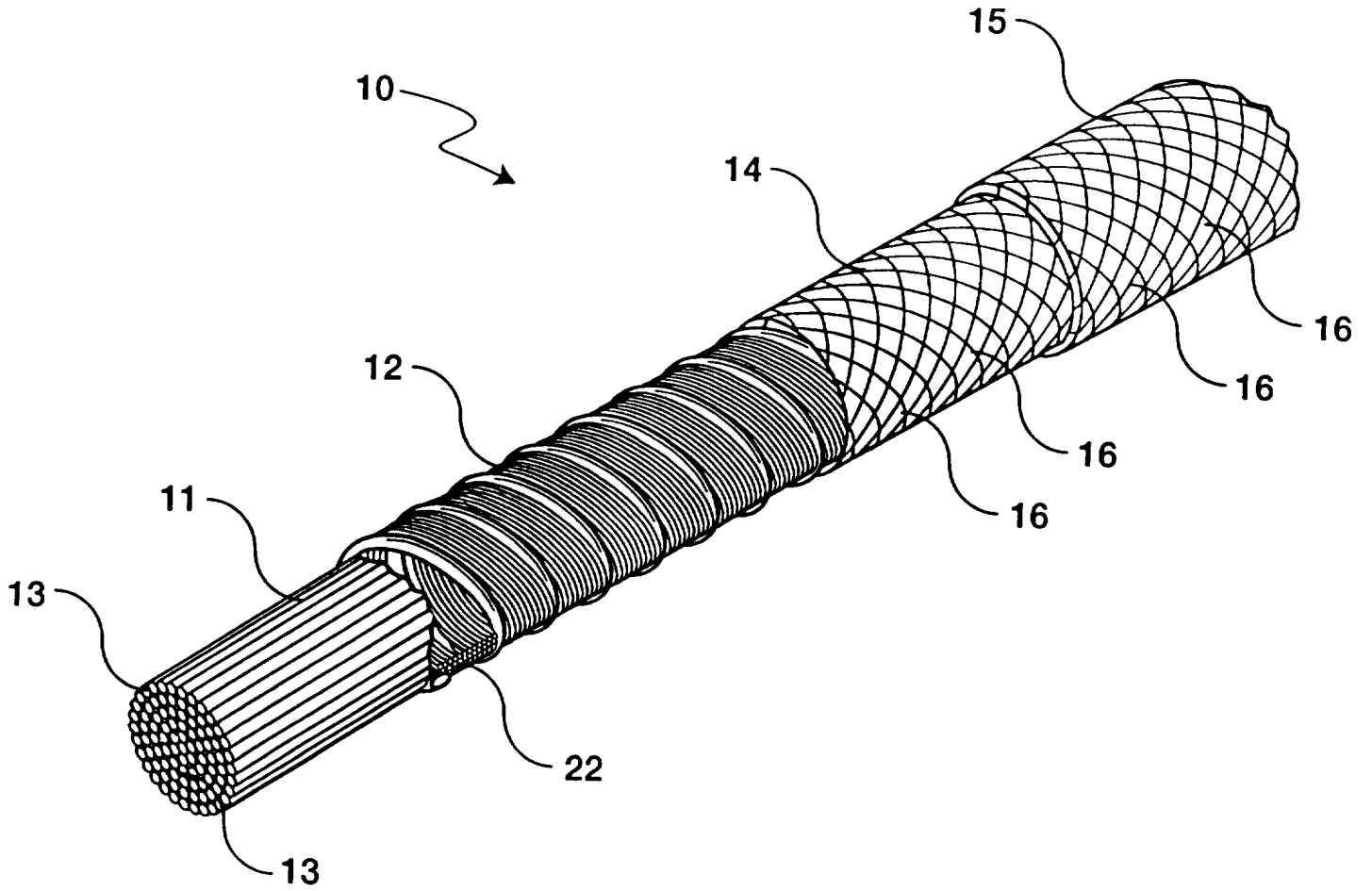

FIG. 4

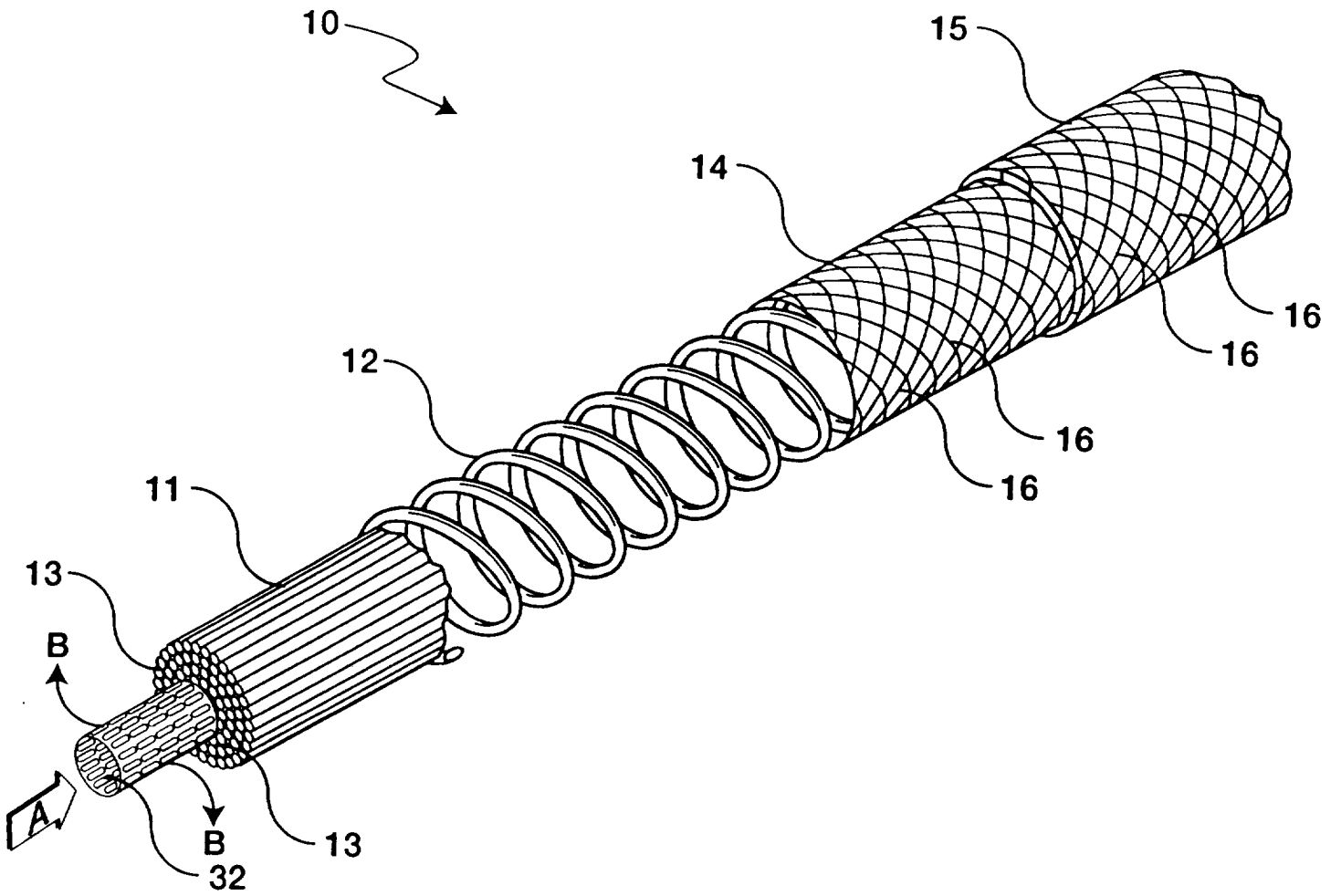

FIG. 5

adjacent elements, thermal conductivity and expansion, seal seating, seal hysteresis, and many others.

5 In today's advanced aerospace engines and vehicles a critical factor in effective sealing is the ability of the seal to supply sufficient resiliency and flexibility at very high temperatures and over large temperature differentials. These advanced aerospace engines and vehicles often employ ceramics, metals, or composites capable of operating at extremely high temperatures, often in excess of 1500 degrees Fahrenheit. For these reasons, advanced aerospace engines and 10 vehicles require high temperature resilient seals to block high temperature flow or minimize engine purge/coolant requirements. Specifically, relative thermal growths between components due to temperature transients and components made of materials with widely different coefficients of thermal expansion (CTE) require resilient seals. Furthermore, seal designs are required that maintain 15 preload during transient and steady-state operation.

Prior Art

20 Conventional braided rope seals such as disclosed in U.S. Patent 5,358,262 provide adequate resiliency, or spring-back for short-term applications. However, as advanced alloy materials such as intermetallics (e.g. nickel-aluminides, titanium-aluminides, etc.), carbon-carbon composites, and ceramic matrix composites find use in advanced aerospace structures, seals exhibiting significantly higher levels of resiliency without sacrificing temperature capability are 25 required.

Conventional braided rope seals such as disclosed in U.S. Patent 5,358,262 use an inner metallic braided sheath with an external ceramic sheath for use as a high temperature seal between a ceramic component and a metallic component. The seal member includes a multi-layer O-ring seal composed of a bundle of uniaxial elongate ceramic fibers over-laid by a sheath of braided metal wire that is over-laid by a sheath of braided ceramic fibers.

U.S. Patent 5,332,239 discloses a bellows seal made of a central bellows with a plurality of convolutions therein. The bellows is over-laid by a braided ceramic sheath which is over-laid by an outer abrasion-resistant sheath. A coolant may be circulated through the hollow interior of the bellows.

U.S. Patent 5,301,595 discloses a high temperature rope seal for joint packing having a cylindrical core made of bundled and twisted ceramic fibers that is covered by a metallic cover made of a plurality of cross woven strands. Each cross woven strand includes a plurality of round stainless steel wires arranged side-by-side.

U.S. Patent 5,082,293 discloses a high temperature, flexible, fiber-preform seal mounted in a groove in a moveable panel structure. The seal has a uniaxial core of a plurality of fibers encircled by an internal layer of spiral wound fibers. This internal layer is encircled by a plurality of left-hand and right-hand helical fibers that are encircled by an external layer of spiral wound fibers.

U.S. Patent 4,576,081 discloses a ceramic sealing rope with one or more sleeves of woven cross wire surrounding a core strand. Each core strand comprises a plurality of yarns where each yarn surrounds a solid metal wire.

These prior art seals are adequate for narrowly defined applications operating at lower temperatures and requiring limited resiliency. However, today's

(
advanced engines and vehicles operate at temperatures in excess of 1500 degrees Fahrenheit and require seals that exhibit higher levels of seal resiliency and seal flexibility as well as minimal permanent set and minimal hysteresis, that are not attainable with the prior art seals.

5

SUMMARY OF THE INVENTION

10 The objective of the invention is to provide an improved seal for abutting adjacent components subject to movement, vibrations, internal pressures, and temperature changes.

Another object of this invention is to provide an improved resilient seal to seal gaps between adjoining structural elements of advanced aerospace engines and vehicles.

15 Yet another object of this invention is to provide a seal capable of remaining resilient at very high temperatures and during large temperatures differentials.

A further object of this invention is to provide a seal supplying sufficient resiliency when used with advanced structural materials including intermetallics or ceramic matrix composites, amongst others.

20 Another objective of this invention is to provide improved resiliency without sacrificing temperature capability.

Another objective of this invention is to provide an improved seal that exhibits improved resiliency while exhibiting minimal permanent set and minimal hysteresis under very high temperatures.

5 These and other objectives and advantages of the invention are obtained by the improved seal for use in high temperature applications, the general nature of which may be stated as including a resilient member wrapped around the center core, where the resilient member has stiffness and load carrying characteristics not previously exhibited and one or more fiber layers braided around the resilient member.

Optionally the space between the resilient member coils is wrapped or filled, further improving leakage and crush resistance characteristics.

10 Optionally for the highest temperature applications, a porous member is inserted in the center core to distribute coolant along the seal.

Further objects and advantages of this invention will become apparent through considering the ensuing description and drawings.

BRIEF DESCRIPTION OF THE DRAWINGS

15

Preferred embodiments of the invention, illustrative of the best modes in which the applicant has contemplated applying the principles, are set forth in the following description and are shown in the drawings and are particularly and distinctly pointed out and set forth in the appended claims.

20 FIGURE 1 is a perspective view of the preferred embodiment of the resilient braided seal of the present invention;

FIGURE 2 is an enlarged perspective view of one type of sheath fiber having a circular cross-section;

25 FIGURE 3 is an enlarged perspective view of one type of sheath fiber having a rectangular cross-section;

FIGURE 4 is a perspective view of an alternate embodiment where the space between the resilient member coils is filled;

FIGURE 5 is a perspective view of an alternate embodiment where a porous member is inserted in the core to supply coolant to the seal for the highest temperature applications;

Similar numerals refer to similar parts throughout the drawings.

DESCRIPTION OF THE PREFERRED EMBODIMENTS

10 A resilient braided rope seal is indicated generally as 10 and is shown particularly in FIGURE 1. This resilient braided rope seal 10 includes a core filler 11, a resilient member 12, and one or more tightly braided sheath layer(s) 14 and 15. More particularly, core 11 of braided rope seal 10 includes a plurality of fibers 13 covered by resilient member 12, an inner sheath layer 14 and one or
15 more outer sheath layer(s) 15. Inner sheath 14 and outer sheath 15 each include a plurality of sheath fibers 16. Resilient member 12 is wrapped around core 11 in a helical fashion to add resiliency to seal 10. Resilient member 12 provides resistance to lateral loads applied to said seal. Depending on application stiffness requirements, the resilient member 12 is wrapped either tightly or loosely around
20 the flexible core 11. The multiple layers of fibers 14 and 15 are braided around resilient member 12 in an optimal configuration to minimize leakage or permeability of the seal structure.

Core filler 11 is crush, leakage, and heat-resistant and may be manufactured of any suitable material which provides these critical characteristics.
25 As indicated above, the preferred embodiment of core filler 11 includes a plurality

of fibers 13 uniaxially extending in an elongated, parallel, and contiguous manner with reference to one another. The core element 11 may also be twisted on its axis. Furthermore, the core element 11 can be braided using 2-, 3-, or multi- dimensional braiding techniques. The dimensions of each of the fibers and the plurality of all fibers making up the core should be optimized to meet the preferred minimum permeability and flexibility/stiffness constraints as controlled by increases and decreases in individual and overall diameters. Core filler 11 is designed to provide additional stiffness to the seal beyond that which the resilient member 12 provides. The core also limits the total amount of seal deformation either under normal operating conditions or under extreme cases where an over-temperature condition could yield the resilient member.

Candidate core 11 materials include but are not limited to ceramic fibers such as alumina, alumina-silica or alumina-boria-silica, silicon nitride, silicon carbide or hybrid fibers, and for lower temperature applications, glass fibers.

In accordance with one of the main features of the present invention, resilient member 12 provides the initial stiffness of the seal, a substantial load carrying capability, and the significant working deflection required in many sealing applications to accommodate relative thermal growths and distortions. Resilient member 12 is made of a material which provides these critical characteristics of stiffness and resiliency and resists permanent deformation at temperature. The preferred embodiment of the resilient member is a canted coil spring of a helical configuration that is wrapped around core 11. Depending on application requirements the resilient member 12 is wrapped either tightly or loosely around the flexible core 11. For instance the resilient member is wrapped tightly around the core 11 where the loads are great and crush resistance is paramount. Each

coil of resilient member 12 is canted, or angled, relative to the vertical plane to permit flexibility of resilient member 12, and to permit resilient member 12 to deflect while maintaining preload in response to lateral forces acting on seal 10. For example, resilient member 12 will deflect in response to lateral loading when positioned between abutting elements subject to structural, thermal, or aerodynamic loads. While resilient member 12 may be manufactured of a variety of materials, in the preferred embodiment, it is manufactured of a high temperature, creep resistant material such as Inconel X-750, Waspalloy, AEREX 350, MAR-M-247, Rene '41, MA 956, Inconel 601, Haynes 25, 188, 230, or 214. One such canted coil spring is available from Bal Seal Engineering Company, Inc. of Santa Ana, CA 92707-3398. (This application does not claim invention of the canted coil spring.)

The tightly braided sheath layers 14 and 15 act to limit flow through the seal, while retaining seal resiliency and flexibility. Sheath elements 14 and 15 respectively are composed of tightly braided sheath elements or fibers 16 extending around core 11 and resilient member 12 so as to minimize flow through the sheath. Braid tension between the sheaths(s) 14 and 15 and the resilient member 12 is optimized for a given application. For instance, where virtually no seal deflection is required under part-load conditions the braided layer(s) 14 and 15 tightly encapsulate the resilient member 12. Only after the applied force exceeds the internal force will the seal compress.

Fibers 16 braided in sheath layers 14 and 15 take a variety of sizes and configurations. However, in the preferred embodiment, the fibers have either a circular or rectangular cross-sectional configuration such as shown in FIG. 2 or FIG. 3 respectively. Each of the fibers 16 includes fine surface and structural features

that minimize parasitic leakage through the contacts between the seal 10 and the surrounding elements.

Fibers 16 may be manufactured of any suitable material which limits flow and remains resilient and flexible. In the preferred embodiment, where durability is important, fibers are wires or ribbons produced from high temperature, oxidation resistant superalloys such as Inconel X-750, Waspalloy, AEREX 350, MAR-M-247, Rene '41, MA 956, Inconel 601, Haynes 25, 188, 230, or 214. Alternatively, where limited scrubbing between the seal and the surrounding occurs, fibers 16 may be manufactured of ceramic fibers such as alumina-silica or alumina-boria-silica, silicon nitride, silicon carbide or hybrid fibers, or for lower temperature applications glass fibers, without departing from the spirit of the present invention.

Overall, the combined stiffness, resiliency, and substantial load carrying capability of resilient member 12 when wrapped around and thus coupled with the minimum permeability and flexible core filler 11, when further combined with the fluid flow limiting capability of sheath layers 14 and 15, results in a significantly improved seal for high temperature applications such as in aerospace engines and vehicles.

Specifically, rope seal 10 exhibits resiliency improvements over the known conventional braided seal technology. During initial cycling of resilient rope seal 10, the seal exhibited significantly less permanent-set (non-recoverable deformation) than the conventional braided seal technology. Specifically, it was found that resilient rope seal 10 having a resilient member 12 exhibited less than 20% of the permanent set of conventional braided rope seals. By way of example, a conventional seal experiences 0.020 in. of first cycle hysteresis, while the

hysteresis of the seal of the present invention is in the range of from 0.003 to 0.005 in.

Another important factor in constructing braided rope seals is load bearing capability. It has been found that when comparing uniform load versus deflection characteristic, resilient braided rope seal 10 reaches a uniform load in significantly fewer conditioning cycles than conventional braided rope seals. Specifically, resilient rope seal 10 with resilient member 12 reaches a uniform loaded versus deflection characteristic in 1/10th or less the number of cycles as the conventional braided rope seal without a resilient member 12. Specifically, a conventional seal often requires 100 cycles to reach a uniform load while the seal of the present invention responds consistently after only 9 cycles.

A third critical factor in constructing braided rope seals is stiffness coupled with flexibility. Stiffness is critical for maintaining preload across the operating range. Resilient braided rope seal 10 with resilient member 12 maintains a higher stiffness during loading than conventional braided rope seals. Specifically, the resilient braided rope seal 10 with resilient member 12 exhibited twice the part-load stiffness of conventional braided rope seals.

Therefore, braided rope seal 10 having a resilient member 12 provides new levels of seal resiliency, seal flexibility, load carrying capabilities, deflection characteristics, and minimization of permanent set and hysteresis without sacrificing flow resistance. The result is that the improved braided rope seal 10 provides the required properties needed in a seal used in advanced aerospace engines and vehicles where relative thermal growths and distortions are important characteristics.

DESCRIPTION OF ALTERNATE EMBODIMENTS

Referring now to Fig. 4, there is shown a second embodiment of the invention including a plurality of fibers 22 extend circumferentially around core 11 and intermediate each pair of adjacent coils of resilient member 12 in order to fill the void existing there between. Filling the space blocks a potential leakage flow path. Furthermore filling this void reduces the possibility of the resilient member 12 causing abrasion to inner sheath 14, for high vibration environments. Fibers 22 may be manufactured of a variety of materials but in the preferred embodiment are manufactured of a superalloy or ceramic material in order to provide sufficient flow and heat resistance.

Referring now to Fig. 5, there is shown a third embodiment of the invention, a porous cooling tube 32 is inserted in the core 11. The porous cooling tube 32 in the center of the seal permits the flow of a seal purge gas as shown by arrow A. The use of this central cooling tube is required at axial engine stations where gas temperatures exceed the maximum use temperature of the seal. The seal purge gas pressure also can be used to inflate the seal structure increasing preload and enhancing sealing contact with the adjacent seal surfaces.

The porous cooling tube 32 is designed to serve as a manifold for delivering high pressure coolant gas at locations where the surrounding temperatures are higher than the seal material limits. Inert purge coolant gas such as helium, flowing radially outward through the wall of the seal as indicated by the arrows B, serve two important functions. The gas cools the seals, and it provides a positive purge of an inert gas to prevent the leakage of potentially explosive fuel-oxygen mixtures common in engine combustion chambers.

In addition to the uses of the seal shown in Figs. 1, 4 and 5, it is contemplated that the seals can be used to seal industrial tubes including heat exchangers, chemical conversion systems, and tube furnaces. It is contemplated that the seals can be used to seal interfaces in turbine engines including combustor cases, and combustor to nozzle joints, amongst others. The seals described can also be used as compliant mounts and/or as seals between advanced structural materials such as intermetallics (nickel-aluminides, titanium-aluminides, etc.), carbon-carbon composites, and ceramic matrix composites used in advanced aerospace systems. Specifically the seals can serve as a combined compliant mount/seal between an intermetallic turbine vane and adjoining superalloy shrouds.

It is contemplated that the seals described can also be used as hypersonic vehicle airframe seals, such as landing gear door seals, elevon control surface seals, rudder control surface seals, body-flap control surface seals, forward canard control surface seals, and crew access door seals.

It is further contemplated that the disclosed seal can be used in high temperature furnace expansion joints, and the like where furnace panel growth is encountered. The seal may also be used to seal joints in high temperature molds or to seal locations in continuous casting processes. The seals may also be used to seal joints in glass processing systems.

The improved resilient braided rope seal provides an effective, safe, and efficient device which achieves the enumerated objectives, provides for eliminating difficulties encountered with prior devices, and solves problems and obtains new results in the art.

In the foregoing description, certain terms have been used for brevity, clearness and understanding; but no unnecessary limitations are to be implied therefrom beyond the requirement of the prior art, because such terms are used for descriptive purposes and are intended to be broadly construed.

5

Moreover, the description and illustration of the invention is by way of example, and the scope of the invention is not limited to the exact details shown or described.

10

Having now described the features, discoveries and principles of the invention, the manner in which the improved resilient braided rope seal is constructed and used, the characteristics of the construction, the advantages, new and useful results obtained; and the new and useful structures, devices, elements, arrangements, parts and combinations, are set forth in the appended claims.

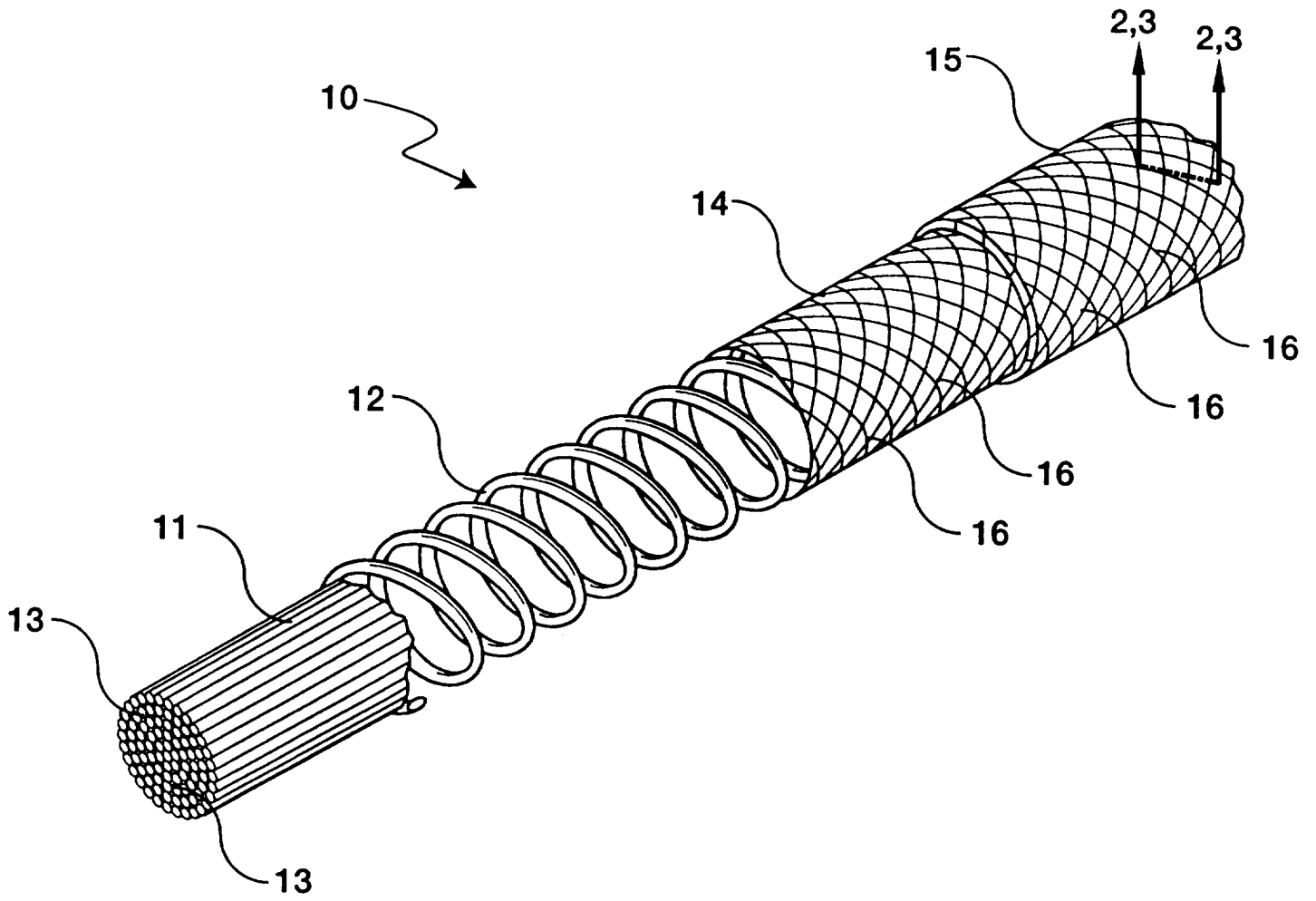

FIG. 1

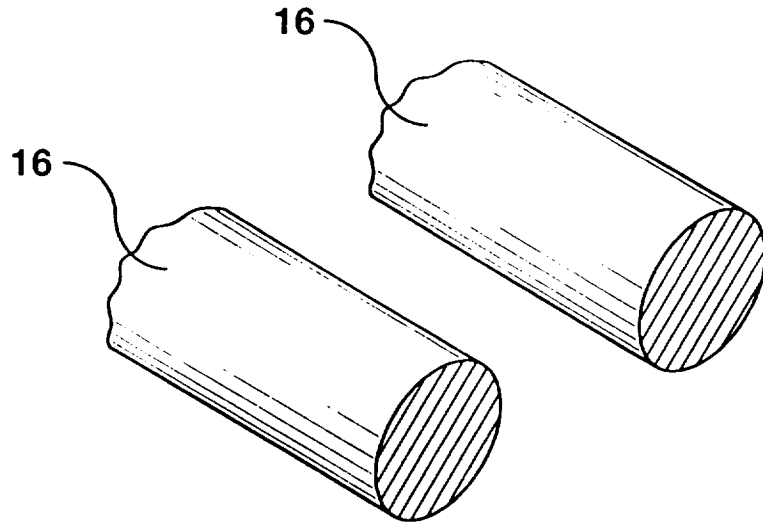

FIG. 2

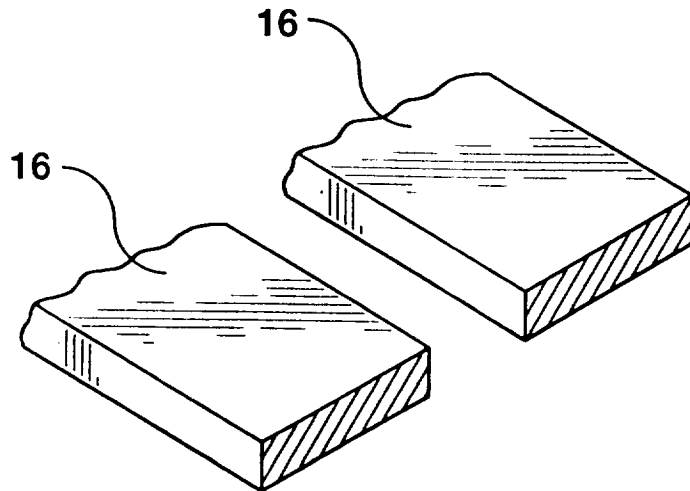

FIG. 3

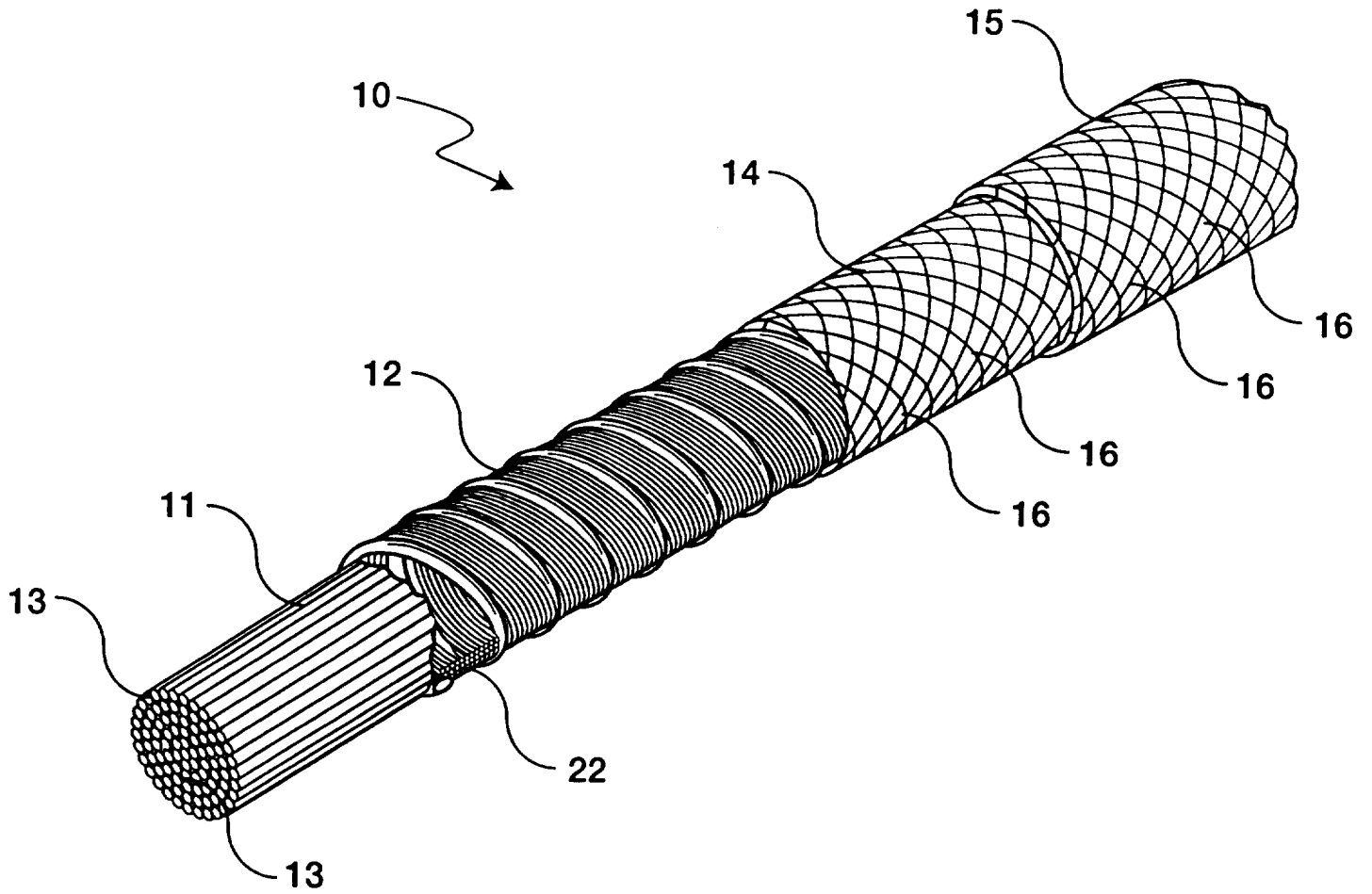

FIG. 4

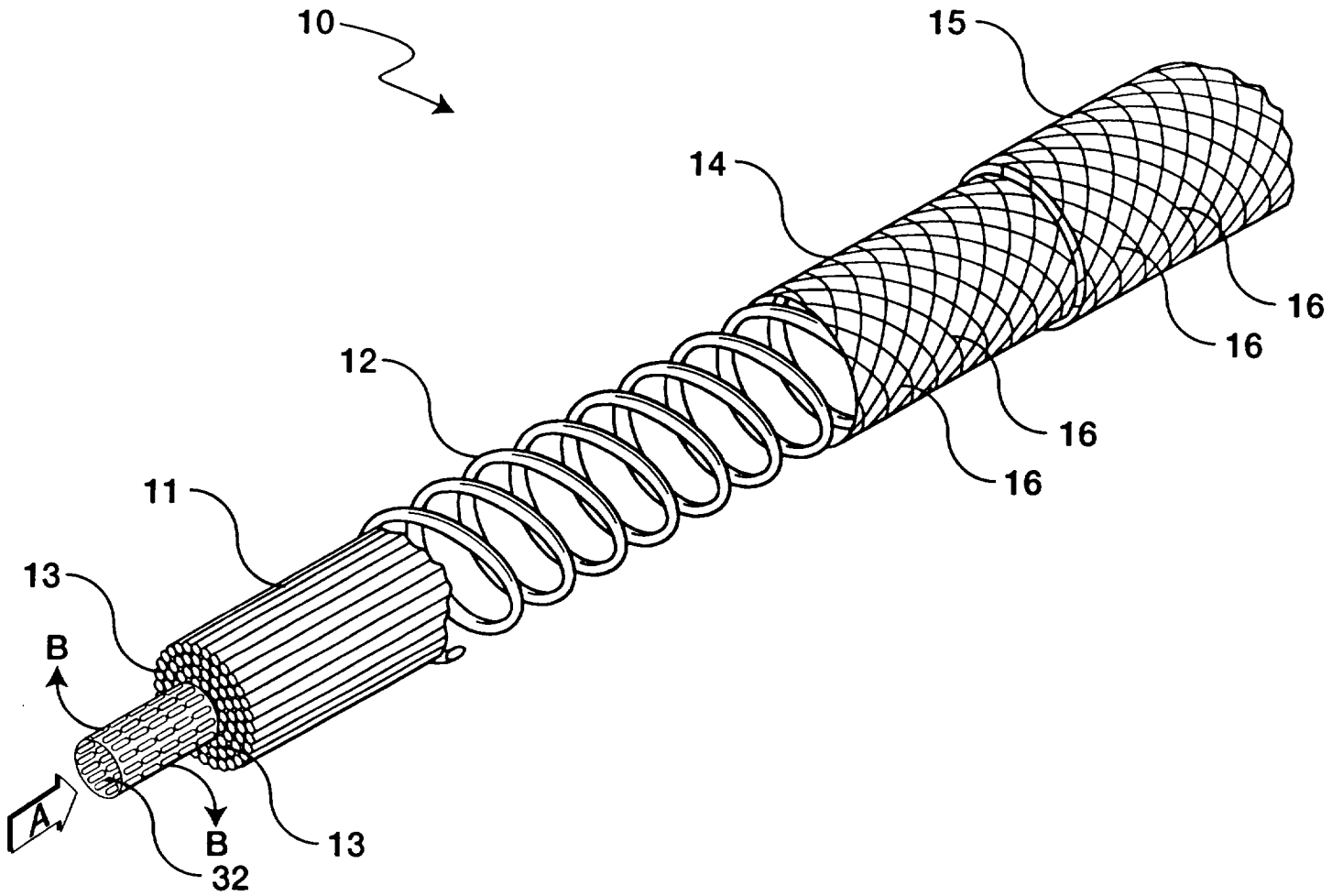

FIG. 5