

Report 10738
1 April 1996

METSAT
Advanced Microwave Sounding Unit -A1 (AMSU-A1)
Structural Mathematical Model

Contract No: NAS 5-32314
CDRL: 102b

Submitted to:

National Aeronautics and Space Administration
Goddard Space Flight Center
Greenbelt, Maryland 20771

Submitted by:

Aerojet
1100 West Hollyvale Street
Azusa, California 91702

TABLE OF CONTENTS

Section		Page
1	INTRODUCTION.....	1
1.1	IDENTIFICATION.....	1
1.2	PURPOSE AND OBJECTIVES	1
1.3	DOCUMENT STATUS AND SCHEDULE.....	1
2	REFERENCE DOCUMENTS	2
3	MODEL DESCRIPTION	3
3.1	FINITE ELEMENT MODEL.....	3
3.2	BOUNDARY CONDITIONS.....	4

TABLES

Tables		Page
I	Concentrated Mass Elements (COMN2).....	6
II	Material Properties.....	9

FIGURES

Figure		Page
1	METSAT AMSU-A1 1331552-1 Sidemount Mounting Bolt Grids.....	5

APPENDIX A FIGURES

Figures		Page
A	APPENDIX A.....	A-1
A1a	METSAT AMSU-A1 1331720-1 Mesh Only.....	A-2
A1b	METSAT AMSU-A1 1331720-1 Mesh Only.....	A-3
A1c	METSAT AMSU-A1 1331720-1 Mesh Only.....	A-4
A1d	METSAT AMSU-A1 1331720-1 Mesh Only.....	A-5
A-2	METSAT AMSU-A1 1331505-1 Lower Baseplate Mesh Only	A-6
A-3	METSAT AMSU-A1 1331404-1 Lower Baseplate Grid Points.....	A-7
A-4	METSAT AMSU-A1 1331404-1 Lower Baseplate Shell Elements	A-8
A-5	METSAT AMSU-A1 1331404-1 Lower Baseplate Beam Elements	A-9
A-6	METSAT AMSU-A1 1331414-1-1 Lower Motor Mount Panel Mesh Only.....	A-10
A-7	METSAT AMSU-A1 1331414-1-1 Lower Motor Mount Panel Grid Points	A-11
A-8	METSAT AMSU-A1 1331414-1-1 Lower Motor Mount Panel Shell Elements.....	A-12
A-9	METSAT AMSU-A1 1331414-1-1 Lower Motor Mount Panel Beam Elements.....	A-13
A-10	METSAT AMSU-A1 1331389-1 Upper Motor Mount Panel Mesh Only	A-14
A-11	METSAT AMSU-A1 1331389-1 Upper Motor Mount Panel Grid Points.....	A-15
A-12	METSAT AMSU-A1 1331389-1 Upper Motor Mount Panel Shell Elements	A-16
A-13	METSAT AMSU-A1 1331389-1 Upper Motor Mount Panel Beam Elements	A-17
A-14	METSAT AMSU-A1 1331389-1 Upper Motor Mount Panel Point Elements.....	A-18
A-15	METSAT AMSU-A1 1331401-1 Lower Front Panel Mesh Only	A-19
A-16	METSAT AMSU-A1 1331401-1 Lower Front Panel Grid Points.....	A-20

FIGURES

Figures		Page
A-17	METSAT AMSU-A1 1331401-1 Lower Front Panel Shell Elements	A-21
A-18	METSAT AMSU-A1 1331401-1 Lower Front Panel Beam Elements	A-22
A-19	METSAT AMSU-A1 1331401-1 Lower Front Panel Point Elements	A-23
A-20	METSAT AMSU-A1 1331652-1 Lower Aft Panel Mesh Only	A-24
A-21	METSAT AMSU-A1 1331652-1 Lower Aft Panel Grid Points	A-25
A-22	METSAT AMSU-A1 1331652-1 Lower Aft Panel Shell Elements	A-26
A-23	METSAT AMSU-A1 1331652-1 Lower Aft Panel Beam Elements	A-27
A-24	METSAT AMSU-A1 1331356-3-1 Upper Baseplate Mesh Only	A-28
A-25	METSAT AMSU-A1 1331356-3-1 Upper Baseplate Grid Points	A-29
A-26	METSAT AMSU-A1 1331356-3-1 Upper Baseplate Shell Elements	A-30
A-27	METSAT AMSU-A1 1331356-3-1 Upper Baseplate Beam Elements	A-31
A-28	METSAT AMSU-A1 1331356-3-1 Upper Baseplate Point Elements & MPCS	A-32
A-29	METSAT AMSU-A1 1331352-3 Upper Front Panel Mesh Only	A-33
A-30	METSAT AMSU-A1 1331352-3 Upper Front Panel Grid Points	A-34
A-31	METSAT AMSU-A1 1331352-3 Upper Front Panel Shell Elements	A-35
A-32	METSAT AMSU-A1 1331352-3 Upper Front Panel Beam Elements	A-36
A-33	METSAT AMSU-A1 1331352-3 Upper Front Panel Point Elements	A-37
A-34	METSAT AMSU-A1 1331642-3 Upper Aft Panel Mesh Only	A-38
A-35	METSAT AMSU-A1 1331642-3 Upper Aft Panel Grid Points	A-39
A-36	METSAT AMSU-A1 1331642-3 Upper Aft Panel Shell Elements	A-40
A-37	METSAT AMSU-A1 1331642-3 Upper Aft Panel Beam Elements	A-41
A-38	METSAT AMSU-A1 1331642-3 Upper Aft Panel Point Elements	A-42
A-39	METSAT AMSU-A1 1356429-1 A1-1 Receiver Assembly Mesh Only	A-43
A-40	METSAT AMSU-A1 1356429-1 A1-1 Receiver Assembly Grid Points	A-44
A-41	METSAT AMSU-A1 1356429-1 A1-1 Receiver Assembly Shell Elements	A-45
A-42	METSAT AMSU-A1 1356429-1 A1-1 Receiver Assembly Beam Elements	A-46
A-43	METSAT AMSU-A1 1356429-1 A1-1 Receiver Assembly Point Elements & MPCS	A-47
A-44	METSAT AMSU-A1 1356409-1 A1-2 Receiver Assembly Mesh Only	A-48
A-45	METSAT AMSU-A1 1356409-1 Receiver Assembly Point Elements	A-49
A-46	METSAT AMSU-A1 1356409-1 Receiver Assembly Grid Points	A-50
A-47	METSAT AMSU-A1 1356409-1 Receiver Assembly Shell Elements	A-51
A-48	METSAT AMSU-A1 1356409-1 Receiver Assembly Beam Elements	A-52
A-49	METSAT AMSU-A1 1331447-1 Lower Right Front Support - Grids, Shells, & Beams	A-53
A-50	METSAT AMSU-A1 1331650-1 Lower Right Panel Mesh only	A-54
A-51	METSAT AMSU-A1 1331650-1 Lower Right Panel - Grid Points	A-55
A-52	METSAT AMSU-A1 1331650-1 Lower Right Panel - Shell Elements	A-56
A-53	METSAT AMSU-A1 1331650-1 Lower Right Panel - Beam Elements	A-57
A-54	METSAT AMSU-A1 1331390-1 Upper Right Front Support - Grids, Shells, & Beams	A-58
A-55	METSAT AMSU-A1 1331651-1 Upper Right Panel Mesh Only	A-59
A-56	METSAT AMSU-A1 1331651-1 Upper Right Panel Grid Points	A-60
A-57	METSAT AMSU-A1 1331651-1 Upper Right Panel Shell Elements	A-61
A-58	METSAT AMSU-A1 1331651-1 Upper Right Panel Beam Elements	A-62
A-59	METSAT AMSU-A1 1331651-1 Upper Right Panel Point Elements	A-63
A-60	METSAT AMSU-A1 1331648-1 Top Panel Mesh Only	A-64
A-61	METSAT AMSU-A1 1331648-1 Top Panel Grid Points	A-65
A-62	METSAT AMSU-A1 1331648-1 Top Panel Shell Elements	A-66
A-63	METSAT AMSU-A1 1331648-1 Top Panel Beam Elements	A-67
A-64	METSAT AMSU-A1 1331640-1 Left Panel (W/Covers) Mesh Only	A-68

FIGURES

Figures	Page
A-65	METSAT AMSU-A1 1331640-1 Left Panel (W/Covers) Grid Points..... A-69
A-66	METSAT AMSU-A1 1331640-1 Left Panel (W/Covers) Shell Elements A-70
A-67	METSAT AMSU-A1 1331445-1 Lower Left Shield Grid Points A-71
A-68	METSAT AMSU-A1 1331405-1 Lower Right Shield Grid Points A-71
A-69	METSAT AMSU-A1 1331445-1 Lower Left Shield Shell Elements A-72
A-70	METSAT AMSU-A1 1331405-1 Lower Right Shield Shell Elements..... A-72
A-71	METSAT AMSU-A1 1331445-1 Lower Left Shield Beam Elements A-73
A-72	METSAT AMSU-A1 1331405-1 Lower Right Shield Beam Elements..... A-73
A-73	METSAT AMSU-A1 1331647-1 Upper Left Shield Grid Points..... A-74
A-74	METSAT AMSU-A1 1331646-1 Upper Right Shield Grid Points A-74
A-75	METSAT AMSU-A1 1331647-1 Upper Left Shield Shell Elements A-75
A-76	METSAT AMSU-A1 1331646-1 Upper Right Shield Shell Elements..... A-75
A-77	METSAT AMSU-A1 1331647-1 Upper Left Shield Beam Elements A-76
A-78	METSAT AMSU-A1 1331646-1 Upper Right Shield Beam Elements..... A-76
A-79	METSAT AMSU-A1 1331600-2 Lower Card Cage Assembly Mesh Only..... A-77
A-80	METSAT AMSU-A1 1331600-2 Lower Card Cage Assembly Grid Points A-78
A-81	METSAT AMSU-A1 1331600-2 Lower Card Cage Assembly Shell Assembly A-79
A-82	METSAT AMSU-A1 1331600-2 Lower Card Cage Assembly Point Elements & MPCS A-80
A-83	METSAT AMSU-A1 1331600-1 Lower Card Cage Card 1 Grids & Shells A-81
A-84	METSAT AMSU-A1 1331600-1 Lower Card Cage Card 2 Grids & Shells A-82
A-85	METSAT AMSU-A1 1331600-1 Lower Card Cage Card 3 Grids & Shells A-83
A-86	METSAT AMSU-A1 1331600-1 Lower Card Cage Card 4 Grids & Shells A-84
A-87	METSAT AMSU-A1 1331162-1 Upper Card Cage Mesh Only A-85
A-88	METSAT AMSU-A1 1331162-1 Upper Card Cage Grid Points S-86
A-89	METSAT AMSU-A1 1331162-1 Upper Card Cage Shell Elements..... A-87
A-90	METSAT AMSU-A1 1331162-1 Upper Card Cage Beam Elements..... A-88
A-91	METSAT AMSU-A1 1331162-1 Upper Card Cage Point Elements..... A-89
A-92	METSAT AMSU-A1 1331162-1 Upper Card Cage MPCS A-90
A-93	METSAT AMSU-A1 1331162-1 Upper Card Cage Card (+X) Grids & Shells A-91
A-94	METSAT AMSU-A1 1331162-1 Upper Card Cage Card (-X) Grids & Shells A-92
A-95	METSAT AMSU-A1 1331380-1 Calibration Source-Warmload (Lower) Mesh Only A-93
A-96	METSAT AMSU-A1 1331380-1 Calibration Source-Warmload (Lower) Grid Points..... A-94
A-97	METSAT AMSU-A1 Calibration Source-Warmload (Lower) Shell Elements..... A-95
A-98	METSAT AMSU-A1 Calibration Source-Warmload (Lower) Point Elements A-96
A-99	METSAT AMSU-A1 1331380-2 Calibration Source-Warmload (Upper) Mesh Only..... A-97
A-100	METSAT AMSU-A1 1331380-2 Calibration Source-Warmload (Upper) Grid Points..... A-98
A-101	METSAT AMSU-A1 1331380-2 Calibration Source-Warmload (Upper) Shell Elements A-99
A-102	METSAT AMSU-A1 1331380-2 Calibration Source-Warmload (Upper) Point Elements A-100
A-103	METSAT AMSU-A1 1331406-1 Beam Support Grid Points A-101
A-104	METSAT AMSU-A1 1331406-1 Beam Support Beam Elements..... A-102
A-105	METSAT AMSU-A1 1355777-1 Lower Reflector Assembly Mesh Only A-103
A-106	METSAT AMSU-A1 1355777-1 Lower Reflector Assembly Grip Points..... A-104
A-107	METSAT AMSU-A1 1355777-1 Lower Reflector Assembly Shell Elements A-105
A-108	METSAT AMSU-A1 1355777-1 Lower Reflector Assembly Beam Elements A-106
A-109	METSAT AMSU-A1 1355777-1 Lower Reflector Assembly Point Elements..... A-107
A-110	METSAT AMSU-A1 1356962-1 Power Control/Monitor Assembly Mesh Only A-108
A-111	METSAT AMSU-A1 Power Control/Monitor - PCB Only - Mesh Only A-109

FIGURES

Figures	Page
A-112	METSAT AMSU-A1 1356962-1 Power Control/Monitor Assembly Printed Wiring Board Grid Points A-110
A-113	METSAT AMSU-A1 1356962-1 Power Control/Monitor Assembly Printed Wiring Board Shell Elements..... A-111
A-114	METSAT AMSU-A1 1356962-1 Power Control/Monitor Assembly Printed Wiring Board Point Elements..... A-112
A-115	METSAT AMSU-A1 1356962-1 Power Control/Monitor Assembly Standoffs Beam Elements..... A-113
A-116	METSAT AMSU-A1 1356790-1 PCM Connector Bracket Mesh Only A-114
A-117	METSAT AMSU-A1 1356962-1 Bracket Power Control/Monitor Assembly Grid Points..... A-115
A-118	METSAT AMSU-A1 1356962-1 Bracket Power Control/Monitor Assembly Shell Elements A-116
A-119	METSAT AMSU-A1 1356962-1 Bracket Power Control/Monitor Assembly Point Elements..... A-117
A-120	METSAT AMSU-A1 1331511-1 Radiator Panel Mesh Only A-118
A-121	METSAT AMSU-A1 1331511-1 Radiator Panel Grid Points A-119
A-122	METSAT AMSU-A1 1331511-1 Radiator Panel Shell Elements..... A-120
A-123	METSAT AMSU-A1 1331511-1 Radiator Panel Point Elements..... A-121
A-124	METSAT AMSU-A1 1331552-1 Sidemount Assembly Mesh Only A-122
A-125	METSAT AMSU-A1 1331552-1 Sidemount Assembly Mesh Only A-123
A-126	METSAT AMSU-A1 1331552-1 Sidemount Assembly Grid Points..... A-124
A-127	METSAT AMSU-A1 1331552-1 Sidemount Assembly Grid Points..... A-125
A-128	METSAT AMSU-A1 1331552-1 Sidemount Assembly Grid Points..... A-126
A-129	METSAT AMSU-A1 1331552-1 Sidemount Assembly Shell Elements A-127
A-130	METSAT AMSU-A1 1331552-1 Sidemount Assembly Shell Elements A-128
A-131	METSAT AMSU-A1 1331552-1 Sidemount Assembly Shell Elements A-129
A-132	METSAT AMSU-A1 1331552-1 Sidemount Assembly Beam Element..... A-130
A-133	METSAT AMSU-A1 1355777-1 Upper Reflector Assembly Grid Points A-131
A-134	METSAT AMSU-A1 1355777-1 Upper Reflector Assembly Grid Points A-132
A-135	METSAT AMSU-A1 1355777-1 Upper Reflector Assembly Shell Elements A-133
A-136	METSAT AMSU-A1 1355777-1 Upper Reflector Assembly Beam Elements A-134
A-137	METSAT AMSU-A1 1355777-1 Upper Reflector Assembly Point Elements A-135

SECTION 1

INTRODUCTION

This Structural Math Model for the Meteorological Satellites Project (METSAT) Advanced Microwave Sounding Units - A (AMSU-A), A1 Module, provides the description for the NASTRAN finite element model that is separately forwarded on computer disk. This is a description of the model at Critical Design Review (CDR), scheduled in April 1996. The report has been prepared in accordance with GSFC S-480-79, Performance Assurance Requirements (PAR) for the Earth Observing System (EOS) & Meteorological Satellites Project (METSAT) Advanced Microwave Sounding Units - A.

1.1 IDENTIFICATION

This is the Structural Math Model for the Meteorological Satellites Project (METSAT) Advanced Microwave Sounding Units - A (AMSU-A), Module A1. This report is submitted to fulfill the requirements of Contract NAS 5-32314 CDRL 102, Structural Math Model, for the METSAT AMSU-A1 Module. The Structural Math Model for the A2 module has been submitted under separate cover.

1.2 PURPOSE AND OBJECTIVES

The purpose of this report is to document the NASTRAN bulk data deck, transmitted under separate cover. The Structural Math Model is used to verify the structural adequacy of the AMSU-A1 instrument for loading environments specified in the GSFC S-480-79, Performance Assurance Requirements (PAR).

1.3 DOCUMENT STATUS AND SCHEDULE

This is the submittal of the Structural Math Model for the METSAT AMSU-A1 Module at CDR, April 1996.

SECTION 2

REFERENCE DOCUMENTS

The following documents were used in the preparation of this report:

SPECIFICATIONS

GSFC-S-480-79 October 10, 1994	Performance Assurance Requirements for the Earth Observing System (EOS) & Meteorological Satellites Project (METSAT) Advanced Microwave Sounding Units - A
GSFC 422-11-12-01	General Interface Requirements Document (GIRD) for EOS Common Spacecraft/Instruments EOS PM Project

Aerojet

Report 10737 November 1995	Advanced Microwave Sounding Unit-A (AMSU-A2), Structural Mathematical Model
Report 10805 March 1996	Integrated Advanced Microwave Sounding Unit-A (AMSU-A) METSAT Stress Analysis Report, A1 Module
Report 10372A February 1996	Earth Observing System (EOS)/Advanced Microwave Sounding Unit-A (AMSU-A) Structural Math Model - A1 Module
Report 10381 June 1995	Earth Observing System (EOS)/Advanced Microwave Sounding Unit-A (AMSU-A) Stress Analysis Report, A1 Module
Report 10381 Addendum 1 February 1996	Earth Observing System (EOS)/Advanced Microwave Sounding Unit-A (AMSU-A) Stress Analysis Report, A1 Module

SECTION 3

MODEL DESCRIPTION

3.1 FINITE ELEMENT MODEL

Figures 1a thru 1d display the NASTRAN finite element model of the METSAT AMSU-A1 structure. The basic coordinate system used in the METSAT analysis is identical to that used in the EOS analysis (Ref. Aerojet Report 10381). This orientation differs from the METSAT PAR document which utilizes the spacecraft coordinate system identified on GE ATN Spacecraft Assembly Drawing 3278200. A comparison of systems follows:

Aerojet METSAT Coordinate System	GSFC-S-79 PAR Coordinate System
+X-Axis	-Y-Axis
+Y-Axis	-Z-Axis
+Z-Axis	+X-Axis

The METSAT AMSU-A1 finite element model is a modification of the EOS AMSU-A1 finite element model. The METSAT AMSU-A1 Module is mounted to the spacecraft through a sidemount bracket. The EOS AMSU-A1 Module is mounted from the lower baseplate. The design of the primary structure is essentially the same for the two units except for the following:

1. Lower Baseplate - Different designs and drawings.
2. Sidemount - Only on METSAT.
3. Top Panel - Different designs and drawings.
4. Left Panel - Different designs and drawings.
5. Radiator Panel - Only on METSAT.
6. Signal Processor - METSAT has 2 Cards in Upper Card Cage.
EOS Upper Card Cage is empty. METSAT has 4 different Cards in Lower Card Cage.
7. Power Control/Monitor - Different designed enclosure and connectors.
8. Insulation and Mirror Tile representations - Modified.

The NASTRAN finite element model prepared for EOS AMSU-A1 and shown in Aerojet Report 10381 is modified for the METSAT AMSU-A1 design. In The current METSAT effort, a more refined NASTRAN model has been developed to more accurately represent the METSAT. The model statistics are:

9095	Grids (GRID)
1032	Bar/Beam Elements (CBAR AND CBEAM)
8089	Rectangular Plate Elements (CQUAD4)
664	Triangular Plate Elements (CTRIA3)
385	Point Mass Elements (CONM2)
23	Spring Elements (CELAS1)

The total mass of the model is 119.2 pounds (54.1 Kg). Mass properties, in the Aerojet METSAT Coordinate System Axes, at the center of gravity, are shown below. The cg is measured relative to the sidemount lower corner on the spacecraft side by the lower reflector (GRID 7508).

Mass	119.2 lb.	(54.1 kg)
Center of Gravity		
x	15.213 in	(0.386m)
y	8.839	(0.225)
z	9.918	(0.252)
Moment of Inertia (at cg)		
Ixx	7336 lb-in	(2.147 kg-m ²)
Ixy	36	(0.011)
Ixz	1799	(0.526)
Iyx	36	(0.011)
Iyy	12574	(3.679)
Iyz	151	(0.044)
Izx	1799	(0.526)
Izy	151	(0.044)
Izz	9100	(2.663)

Concentrated mass elements (CONM2's) used in the model are listed in Table I. Material properties used in the model are shown in Table II. Parasitic mass, representing non-structural and miscellaneous items such as insulation, mirror tiles, wiring, mounting hardware, etc., are distributed throughout the model components by non-structural mass additions to the element properties or by increasing the mass density of the material.

Appendix A presents a detailed description of the METSAT NASTRAN finite element model.

3.2 BOUNDARY CONDITIONS

The model is constrained for static design load cases along the three orthogonal axes on the sidemount at each of the 16 spacecraft mounting bolt locations and along the two transverse axes (X and Z in Figure 1) at the 2 dowel pin locations. The constrains are imposed using NASTRAN single point constrain cards.

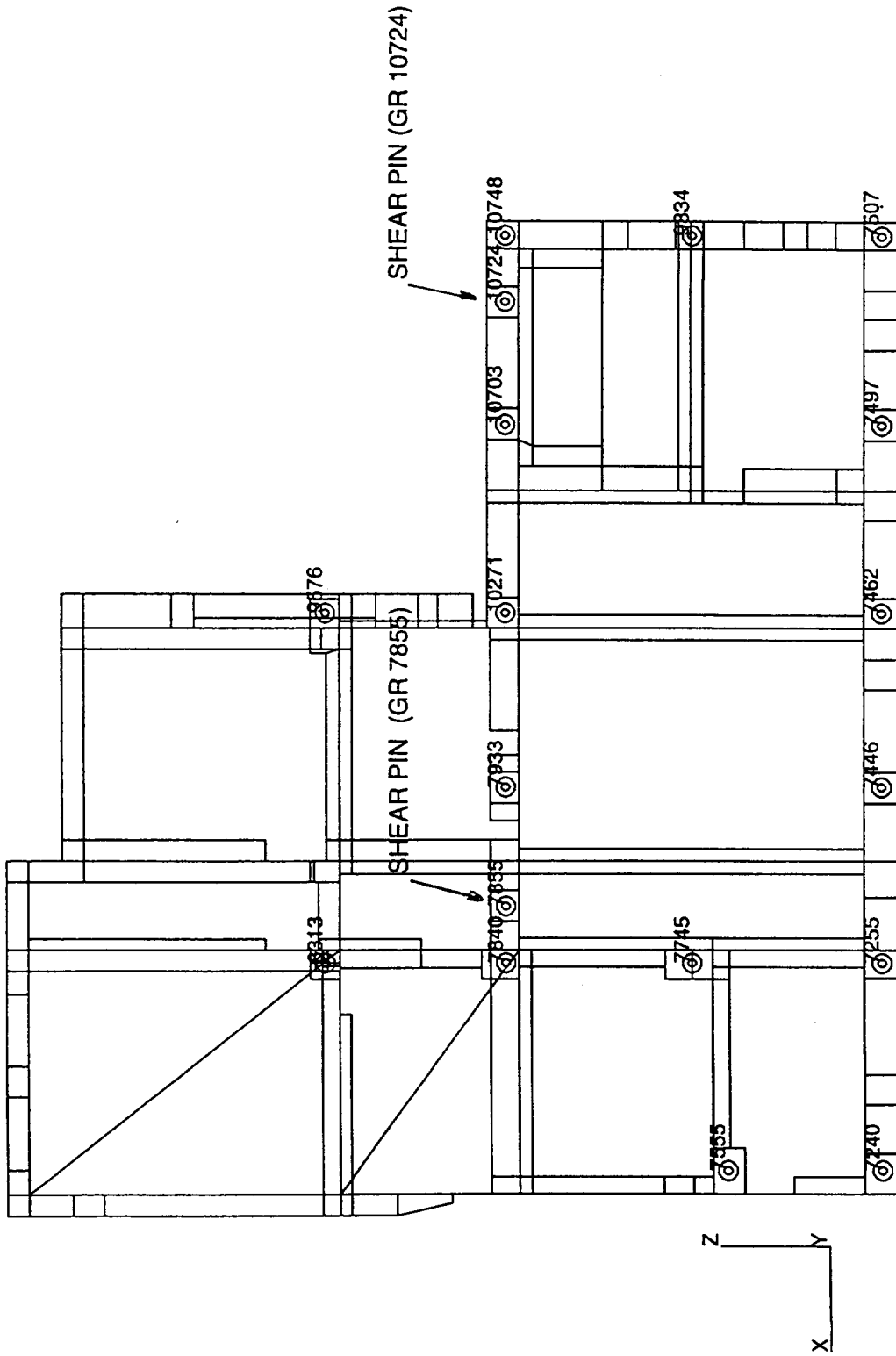

FIGURE 1 METSAT AMSU-A1 1331552-1 SIDEMOUNT MOUNTING BOLT GRIDS

TABLE I CONCENTRATED MASS ELEMENTS (CONM2)

CONM2 ELEMENT	GRID POINT	ITEM	NO. CONM2 (LB)	INCR WEIGHT (LB)	TOTAL WEIGHT (LB)
4957-4976	3001-3010, 3031-3039	LOWER WARMLOAD	20	0.1469	2.938
4977-4996	2941-2950, 2971-2980	UPPER WARMLOAD	20	0.1469	2.938
10341-10344	1345, 2154, 2130, 1365	UPPER CAGE CARD RETAINER	4	0.034	0.136
5747-5748	3735, 3711	LOWER CARD CAGE CARDS	2	0.601	1.202
5749-5758	3706-3708, 3730-3732 3749-3750, 3760-3761	LOWER CARD CAGE CARDS	10	0.475	4.75
5743-5744	3676-3677	LOWER CARD CAGE CARDS	2	0.057	0.114
5759-5760	3764, 3753	LOWER CARD CAGE CARDS	2	0.64	1.28
5761-5762	3663, 3665	LOWER CARD CAGE CARDS	2	0.251	0.502
5745-5746	3699-3700	LOWER CARD CAGE CARDS	2	0.294	0.588
1748-1750	2547, 2549, 2551	UPPER SHELF COMPONENTS	3	0.40333	1.20999
1742-1745	2419, 2421, 2353, 2355	UPPER SHELF COMPONENTS	4	0.03543	0.14172
1746-1747	2405, 2366	UPPER SHELF COMPONENTS	2	0.07085	0.1417
1706-1717	2460, 2502, 2473, 2487 2475, 2489, 2314, 2300 2302, 2287, 2289, 2275	UPPER SHELF COMPONENTS	12	0.13445	1.6134
1738-1741	2422, 2426, 2356, 2360	UPPER SHELF COMPONENTS	4	0.23668	0.9467
1722-1725	2420, 2424, 2354, 2358	UPPER SHELF COMPONENTS	4	0.22168	0.8867
1718-1721	2465, 2470, 2521, 2526	UPPER SHELF COMPONENTS	4	0.39656	1.58625
1726-1737	2572, 2577, 2534, 2539 2520, 2525, 2464, 2469 2318, 2323, 2241, 2242	UPPER SHELF COMPONENTS	12	0.39656	4.75874
859-862	1777, 1779, 1826, 1828	LOWER SHELF COMPONENTS	4	0.0001	0.0004
847-850	1774, 1776, 1842, 1844	LOWER SHELF COMPONENTS	4	0.53194	2.12775
855-858	1727-1728, 1743-1744	LOWER SHELF COMPONENTS	4	0.1025	0.41
835-838	1778, 1800, 1827, 1850	LOWER SHELF COMPONENTS	4	0.39281	1.57125
866-869	1629, 1631, 1647, 1649	LOWER SHELF COMPONENTS	4	0.1725	0.69
870-877	1634, 1637, 1641, 1652, 1659, 1671, 1677, 1678	LOWER SHELF COMPONENTS	8	0.24838	1.987
878-881	1669-1670, 1699-1700	LOWER SHELF COMPONENTS	4	0.0635	0.254
882-885	1674, 1676, 1703, 1705	LOWER SHELF COMPONENTS	4	0.292	1.168
886-889	1781, 1783, 1811, 1814	LOWER SHELF COMPONENTS	4	0.12	0.48
890-893	1716, 1718, 1764, 1766	LOWER SHELF COMPONENTS	4	0.15925	0.637
894-897	1731-1732, 1762-1763	LOWER SHELF COMPONENTS	4	0.19375	0.775
898-903	1719, 1720, 1735, 1751 1767-1768	LOWER SHELF COMPONENTS	6	0.10333	0.62
843-846	1805, 1808, 1855, 1858	LOWER SHELF COMPONENTS	4	0.39031	1.56125
851-854	1625, 1628, 1691, 1694	LOWER SHELF COMPONENTS	4	0.52856	2.11425
863-865	1852-1854	LOWER SHELF COMPONENTS	3	0.22933	0.688
839-842	1664, 1667, 1712, 1715	LOWER SHELF COMPONENTS	4	0.34	1.36

TABLE I CONCENTRATED MASS ELEMENTS (CONM2)

CONM2 ELEMENT	GRID POINT	ITEM	NO. CONM2 (LB)	INCR WEIGHT (LB)	TOTAL WEIGHT (LB)
10677-10684	9561, 8876, 8315, 7842 7747, 7556, 9425, 9251	SIDEMOUNT T-BLANKET	8	0.04	0.32
10035-10037	2768, 2764, 2760	ALIGNMENT CUBE	3	0.116	0.348
4997-5000	2224, 2223, 2218, 2219	DC/DC CONVERTER	4	0.91	3.64
4945-4956	1970-1981	LOWER FEEDHORN & SHROUD	12	0.04167	0.5
4933-4944	2036-2038, 2047-2050 2058-2062	UPPER FEEDHORN & SHROUD	12	0.04167	0.5
4630	4077	LOWER REFL MOTOR ROTOR	1	1.25	1.25
4629	4078	LOWER REFL RESVLR ROTOR	1	0.31	0.31
4755-4770	4630-4645	LOWER REFL MOTOR STATOR	16	0.1	1.6
4771-4786	4646-4661	LOWER REFL RESOLVER	16	0.047	0.752
4215	4391	UPPER REFL MOTOR ROTOR	1	1.25	1.25
4214	4392	UPPER REFL RESVLR ROTOR	1	0.31	0.31
4707-4722	4597-4612	UPPER REFL MOTOR STATOR	16	0.1	1.6
4723-4738	4613-4628	UPPER REFL RESOLVER	16	0.047	0.752
5001-5004	1961, 1963, 1885, 1883	DETECTOR PREAMP	4	0.7225	2.89
5037-5054	1435, 1445, 1580-1586 1588, 1590-1596, 1598	UPPER B-PLATE T-BLANKET	18	0.00257	0.04633
5055-5706	2884-2899	LOWER REFL T-BLANKET	16	0.00182	0.02904
5071-5086	4597-4612	UPPER REFL T-BLANKET	16	0.00182	0.02904
10665-10676	5706, 5674, 5663, 5630	PWR CNTRL/MON CONNECTOR	4	0.017	0.068
10669-10672	5621, 5620, 5714, 5682	PWR CNTRL/MON CONNECTOR	4	0.017	0.068
10673-10676	11752, 11754, 11730, 11736	PWR CNTRL/MON CONNECTOR	4	0.017	0.068
6833	6669	PWR CNTRL/MON CONNECTOR	1	0.044	0.044
6834	6670	PWR CNTRL/MON CONNECTOR	1	0.022	0.022
6835	6671	PWR CNTRL/MON CONNECTOR	1	0.022	0.022
6836-6838	5966, 5911, 5999	PWR CNTRL/MON RELAY	3	0.06	0.18
6839-6841	6044, 5994, 6015	PWR CNTRL/MON RELAY	3	0.06	0.18

TABLE I CONCENTRATED MASS ELEMENTS (CONM2)

CONM2 ELEMENT	GRID POINT	ITEM	NO. CONM2 (LB)	INCR WEIGHT (LB)	TOTAL WEIGHT (LB)
5824-5832	2065-2067, 2077-2079 2089-2091	TRANSISTOR ASSEMBLY	9	0.055	0.495
10122-10127	10963-10968	RADIATOR PANEL BRACKET	6	0.0053	0.0318
10742-10751	11275, 11323, 11315, 11307 11307, 11299	UP CARD CAGE CONNECTOR	5	0.01	0.05
	11187, 11890, 11882, 11874, 11211	UP CARD CAGE CONNECTOR	5	0.01	0.05
		TOTAL			59.5823

TABLE II MATERIAL PROPERTIES

MAT'RL	MAT'RL	COMPONENT	E	μ	ρ
ID	TYPE		(PSI)		(LB/IN ³)
1	7075 ALUM	UPPER FRONT PANEL, MOTOR MT PANLES	1.03E+07	0.33	0.11
2, 6, 7, 9	6061 ALUM	LOWER BASEPLATE, LOWER FRONT PANEL	9.90E+06	0.33	0.107
		LOWER AFT PANEL, UPPER BASEPLATE			
		UPPER AFT PANEL, LOWER RIGHT PANEL			
		UPPER & LOWER RIGHT FRONT SUPPORTS			
		UPPER RIGHT PANEL, TOP PANEL, LEFT PANEL			
		UPPER & LOWER WARMLoad SHIELDS			
		UPPER & LOWER CARD CAGES			
		UPPER & LOWER WARMLoad STRUCTURES			
3	FIBERGLAS	PWR CTRL/MONITOR PWB, UPPER SHELF BKTS	2.00E+06	0.12	0.07
4	6061 ALUM	LOWER BASEPLATE	9.90E+06	0.33	0.183
5	6061 ALUM	SIDEMOUNT	9.90E+06	0.33	0.12138
8	BERYLLIUM	RF SHELVES	4.25E+07	0.1	0.067
10	FIBERGLAS	LOWER CARD CAGE CIRCUIT CARDS	2.00E+06	0.12	0.16673
11	CRES	POWER CTRL/MONITOR STANDOFFS	2.60E+07	0.27	0.286
12	6061 ALUM	POWER CTRL/MONITOR BKT, RADIATOR PANEL	9.90E+06	0.33	0.098
13	*****	FICTITIOUS MASSLESS MATERIAL	1.00E+02	0.3	1E-06
14	FIBERGLAS	UPPER CARD CAGE CIRCUIT CARDS	2.00E+06	0.12	0.10876
15	6061 ALUM	TOP PANEL W/MIRROR	9.90E+06	0.33	0.10366
30	6061 ALUM	REFLECTOR ASSEMBLIES	9.90E+06	0.33	0.107
106	STEEL	MOTOR SHAFT	2.90E+07	0.3	0.283

*LOWER AFT AND UPPER AFT PANELS, MODELED AS 6061 ALUM, ANALYZED AS 2024 ALUM

APPENDIX A

NASTRAN FINITE ELEMENT MODEL

The NASTRAN finite element model of the METSAT AMSU-A1 Module is shown in its entirety in Figures A1a thru A1d in this appendix. Figure A1d is a section view of the model, showing the components modeled in the interior (i.e. shelves, card cages, warmload structures). Elements and grids are highlighted in the piece part models that are combined to form the METSAT AMSU-A1 Module model.

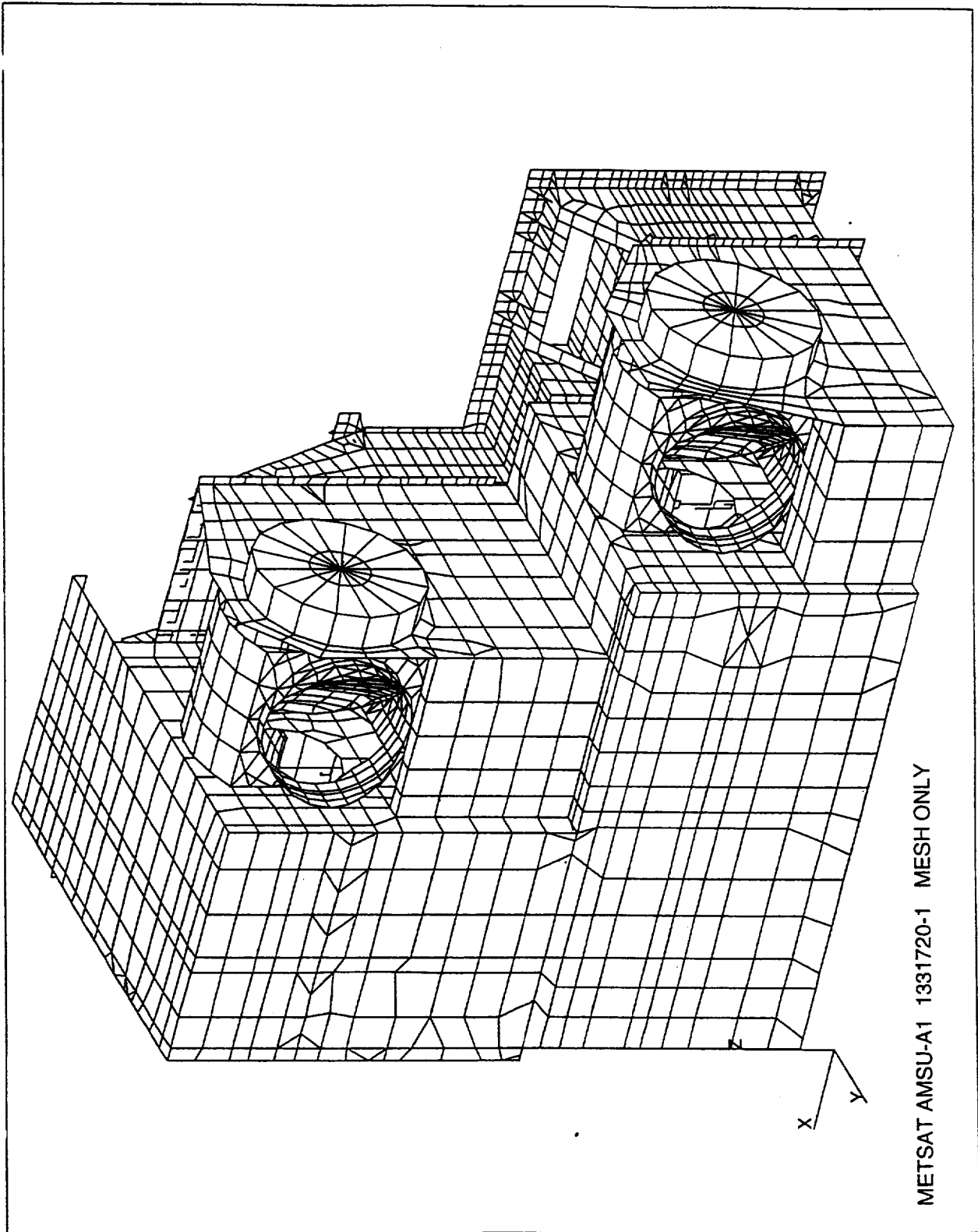

Figure A-1a METSAT AMSU-A1 1331720-1 Mesh Only

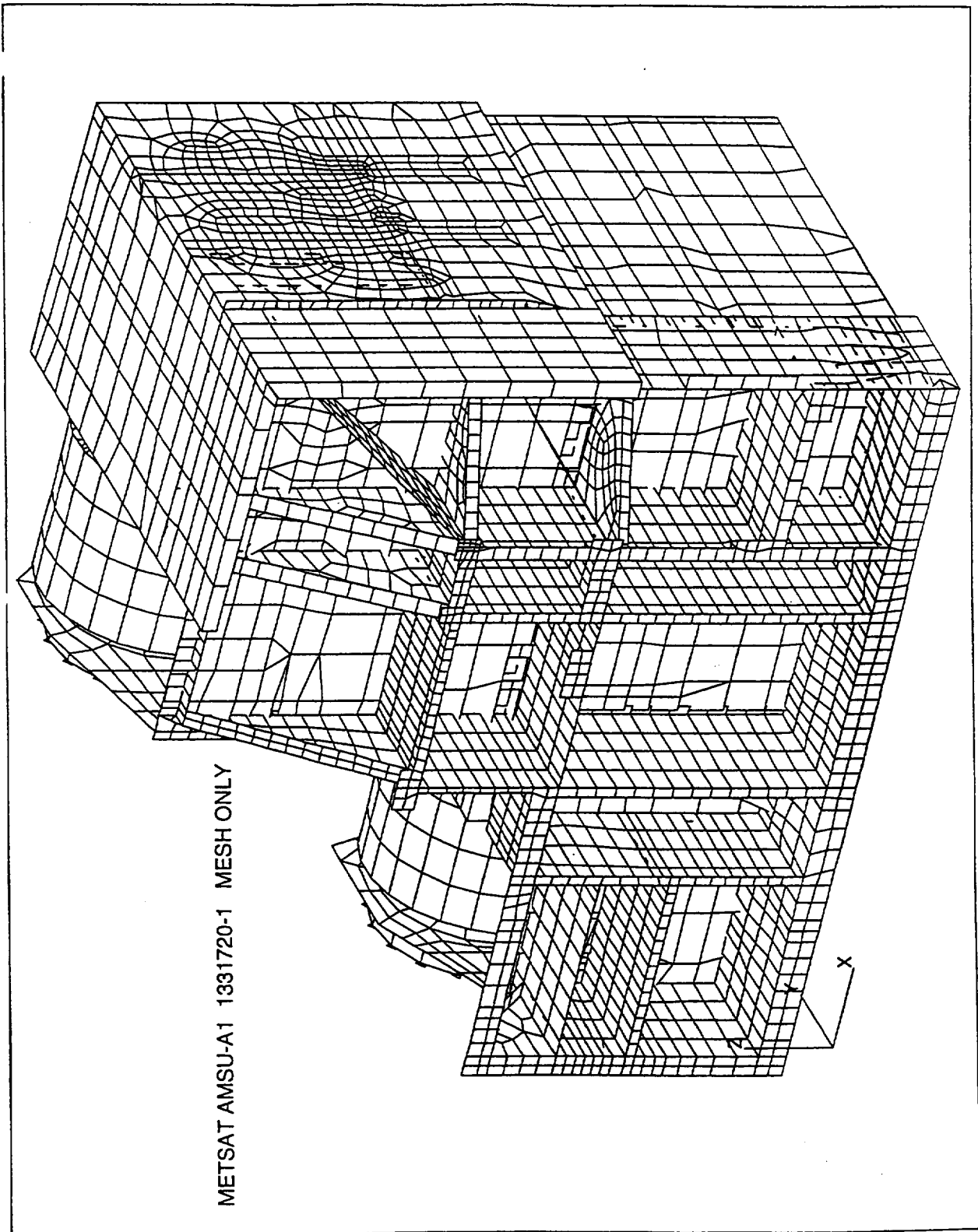

Figure A-1b METSAT AMSU-A1 1331720-1 Mesh Only

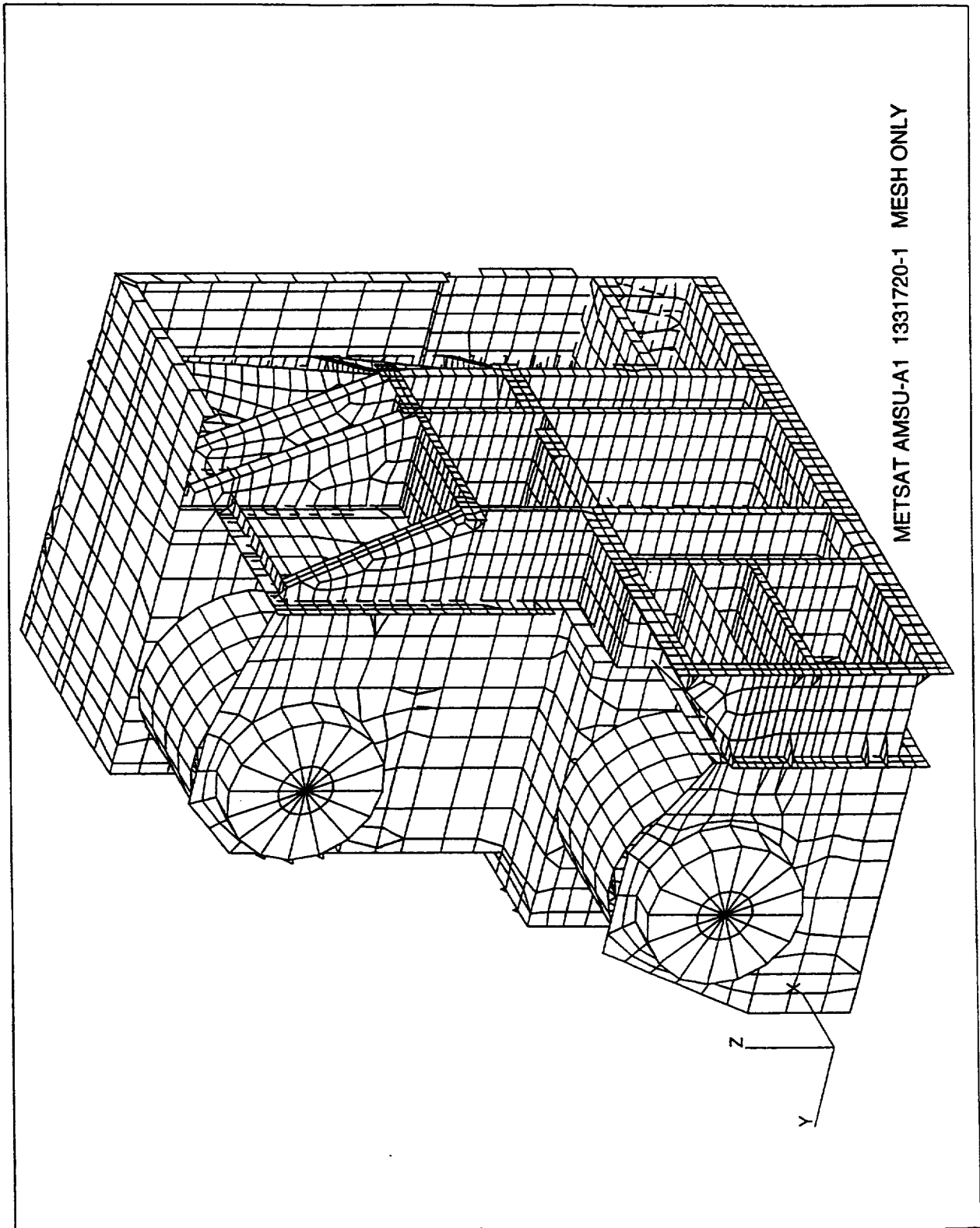

Figure A-1c METSAT AMSU-A1 1331720-1 Mesh Only

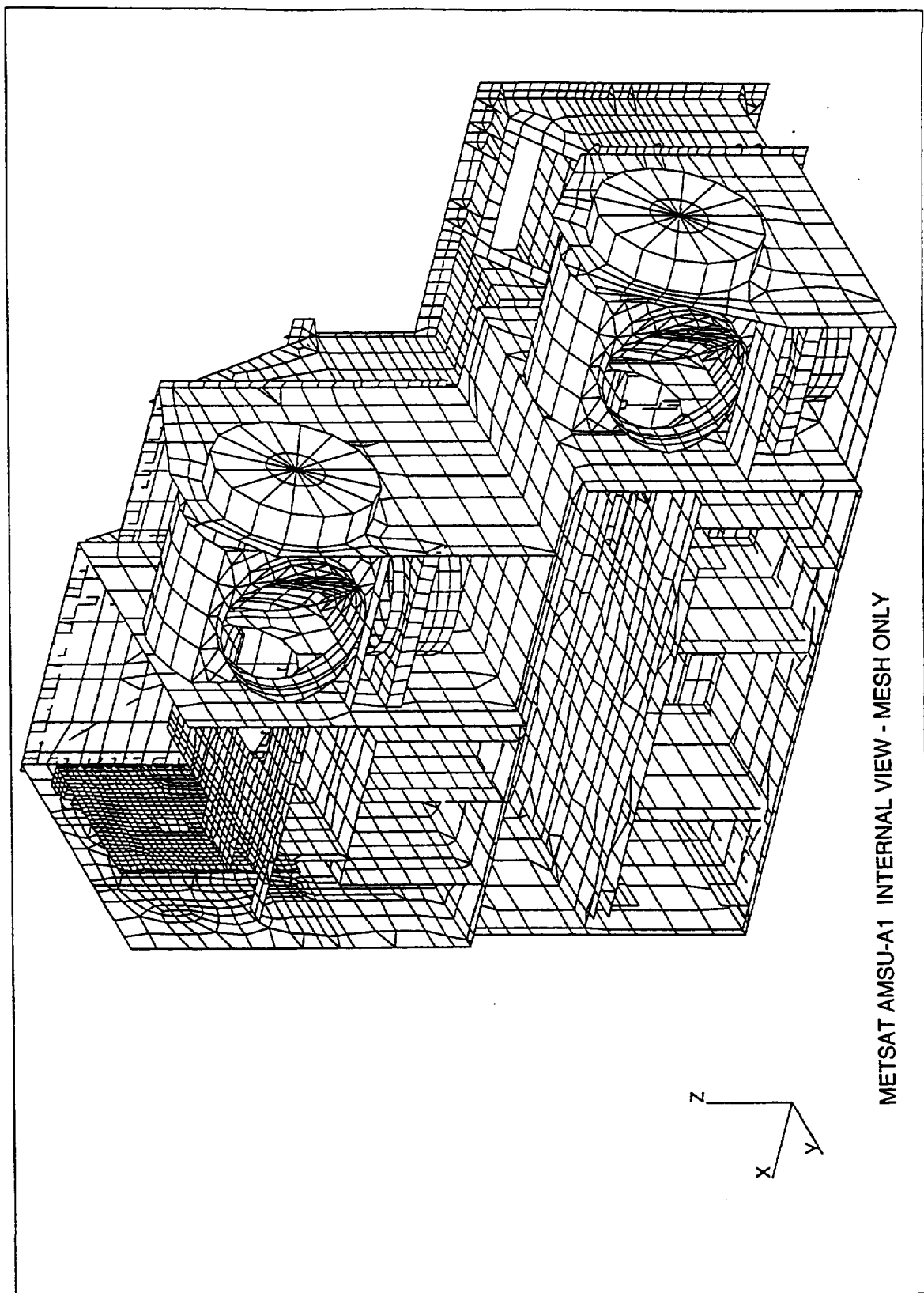

Figure A-1d METSAT AMSU-A1 1331720-1 Mesh Only

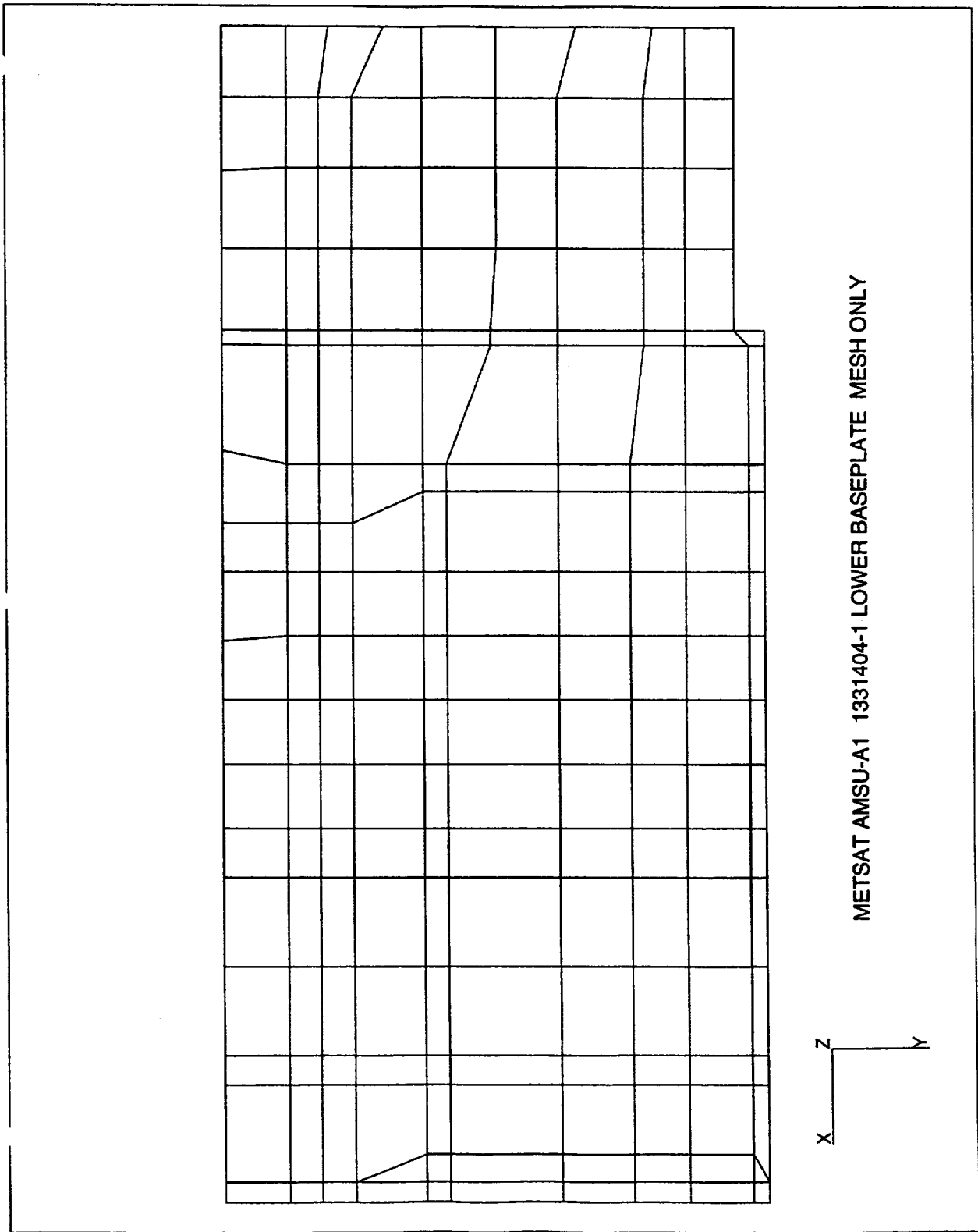

Figure A-2 METSAT AMSU-A1 1331404-1 Lower Baseplate Mesh Only

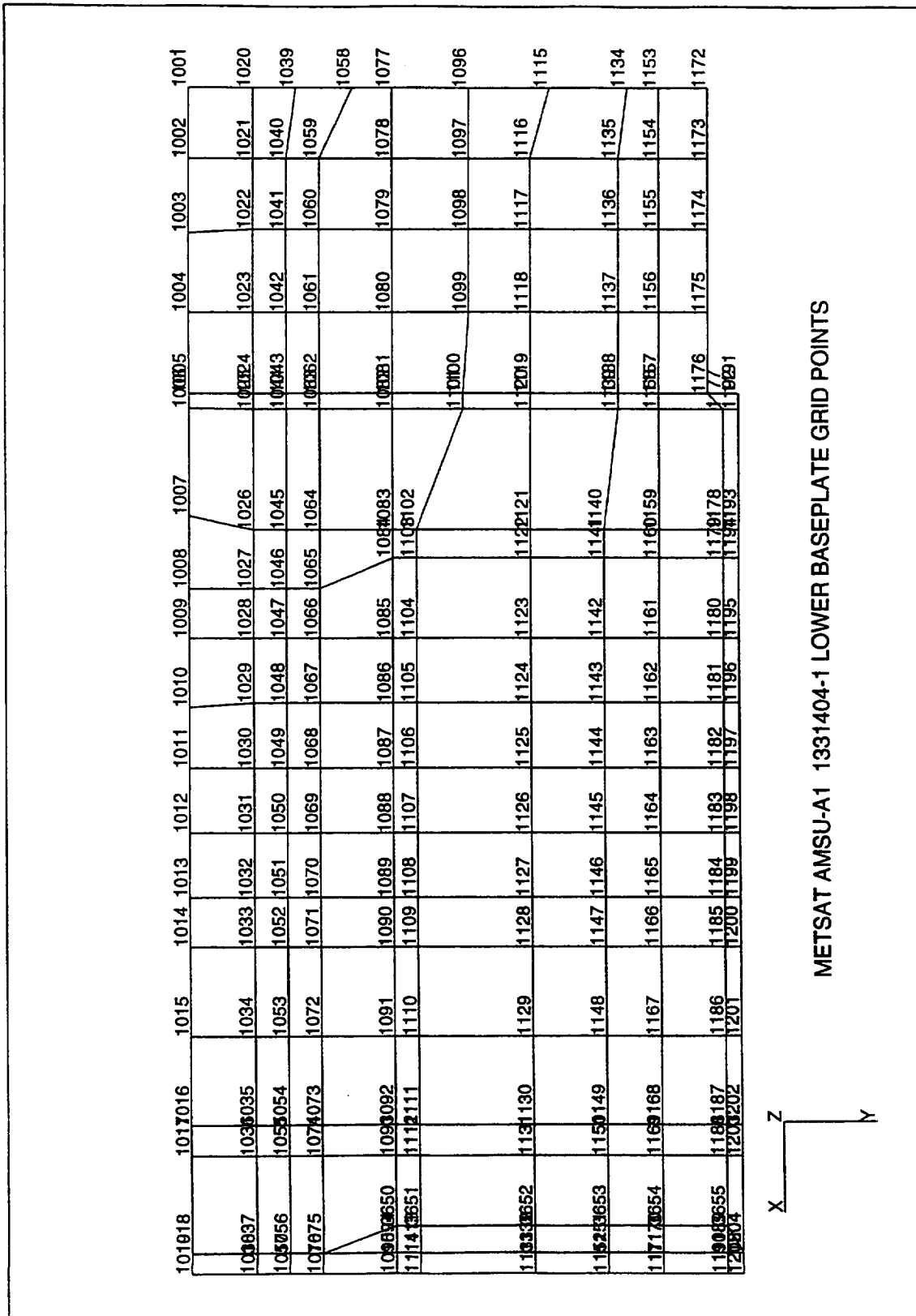

Figure A-3 METSAT AMSU-A1 1331404-1 Lower Baseplate Grid Points

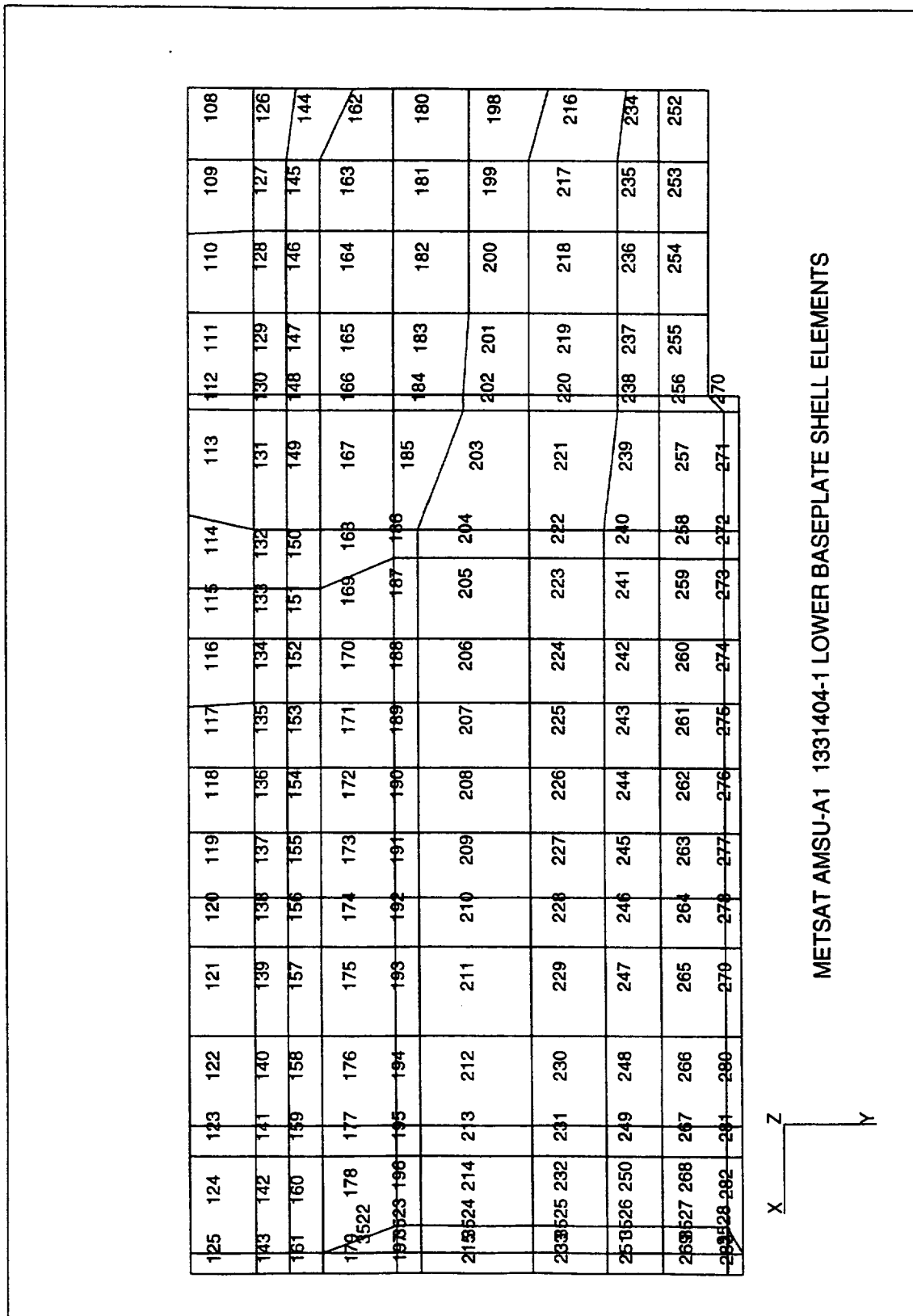

Figure A-4 METSAT AMSU-A1 1331404-1 Lower Baseplate Shell Elements

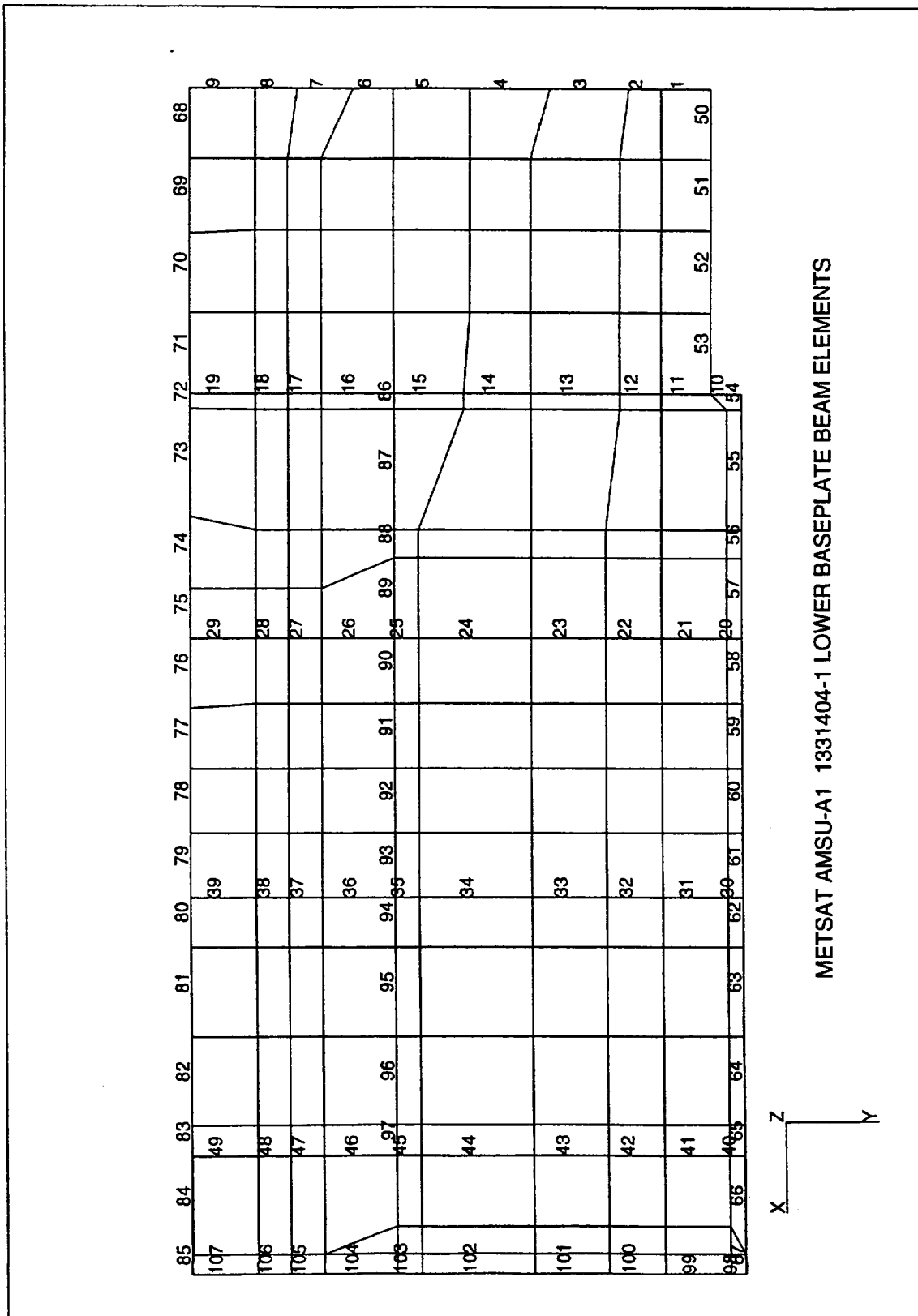

Figure A-5 METSAT AMSU-A1 1331404-1 Lower Baseplate Beam Elements

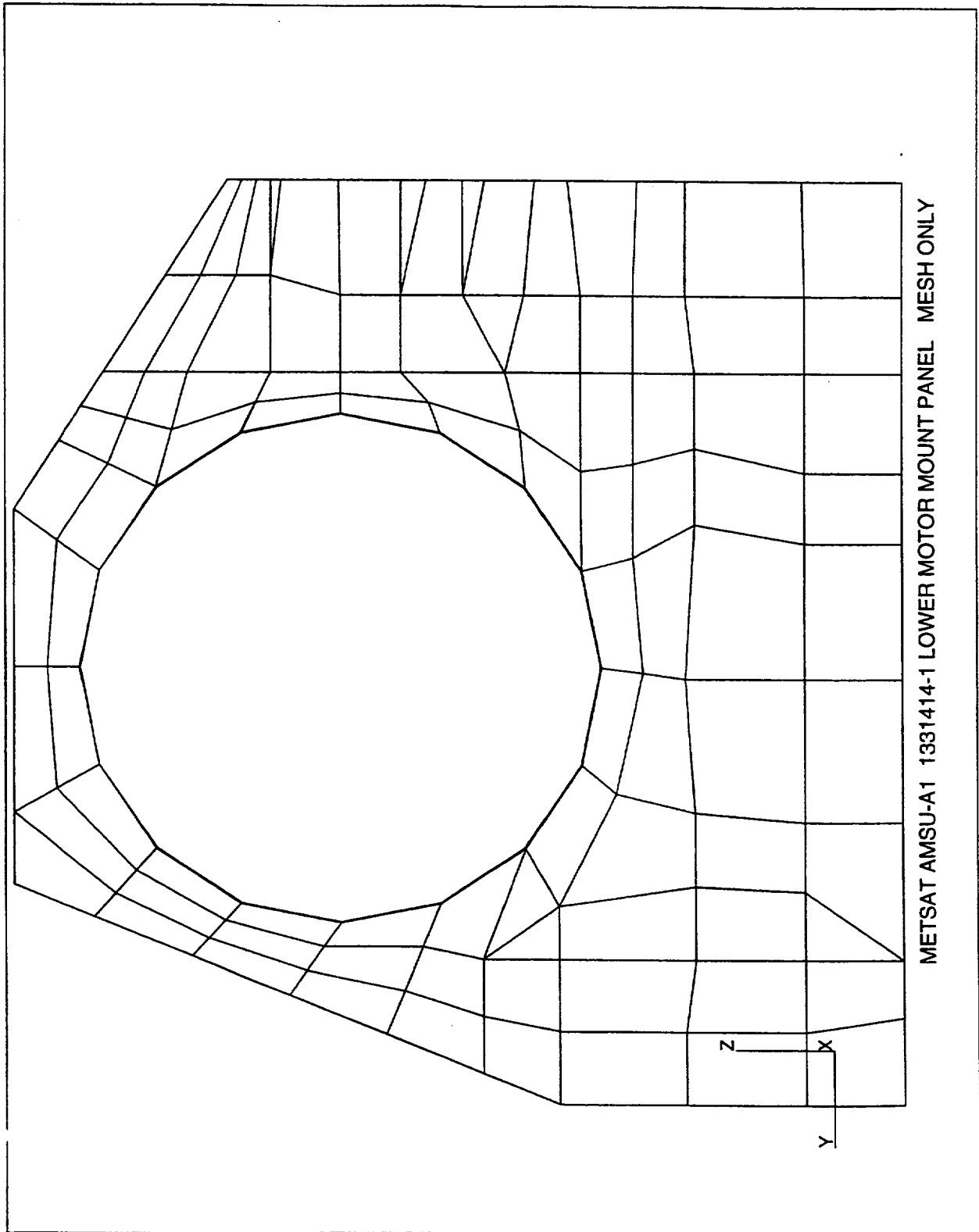

Figure A-6 METSAT AMSU-A1 1331414-1 Lower Motor Mount Panel Mesh Only

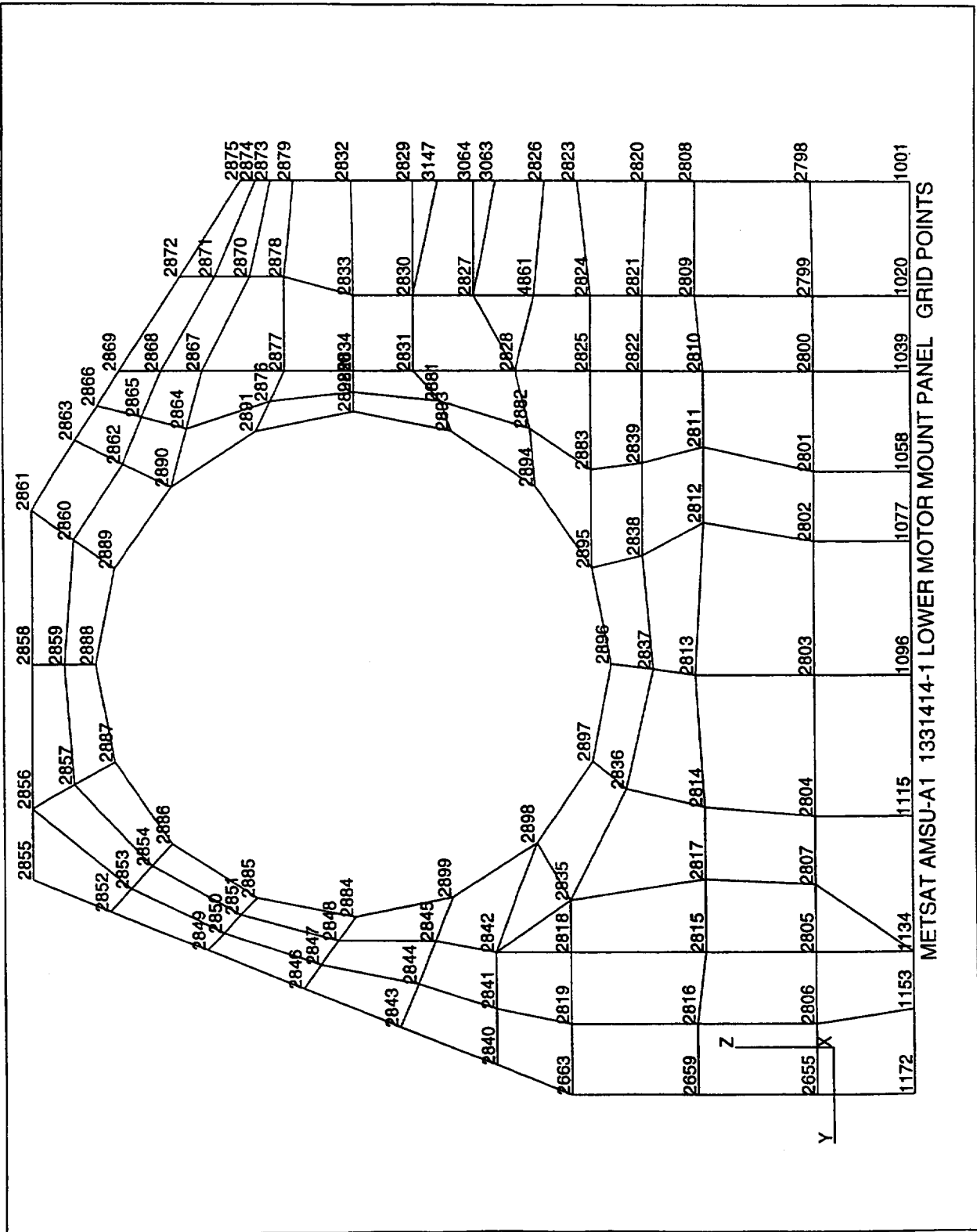

Figure A-7 METSAT AMSU-A1 1331414-1 Lower Motor Mount Panel Grid Points

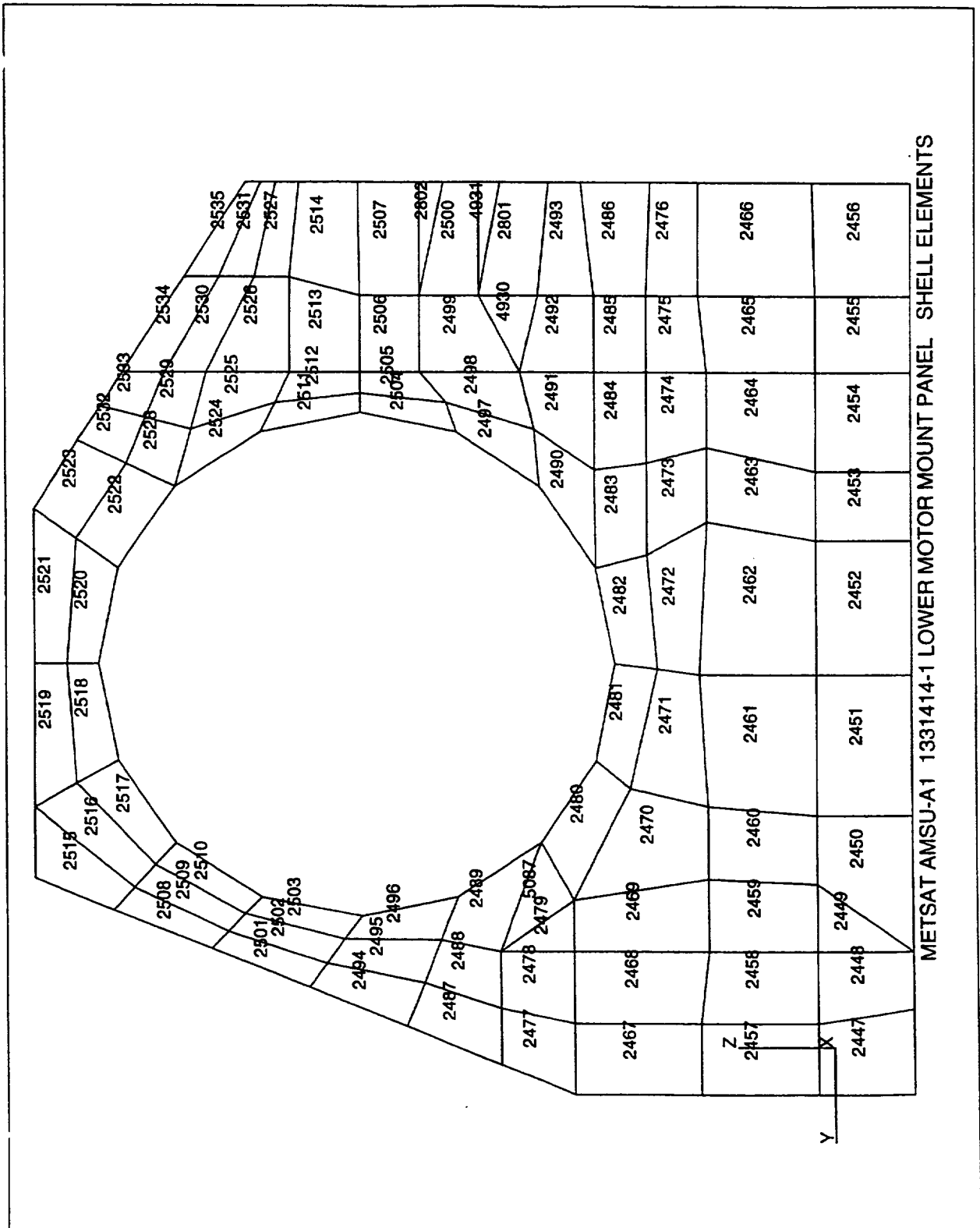

Figure A-8 METSAT AMSU-A1 1331414-1 Lower Motor Mount Panel Shell Elements

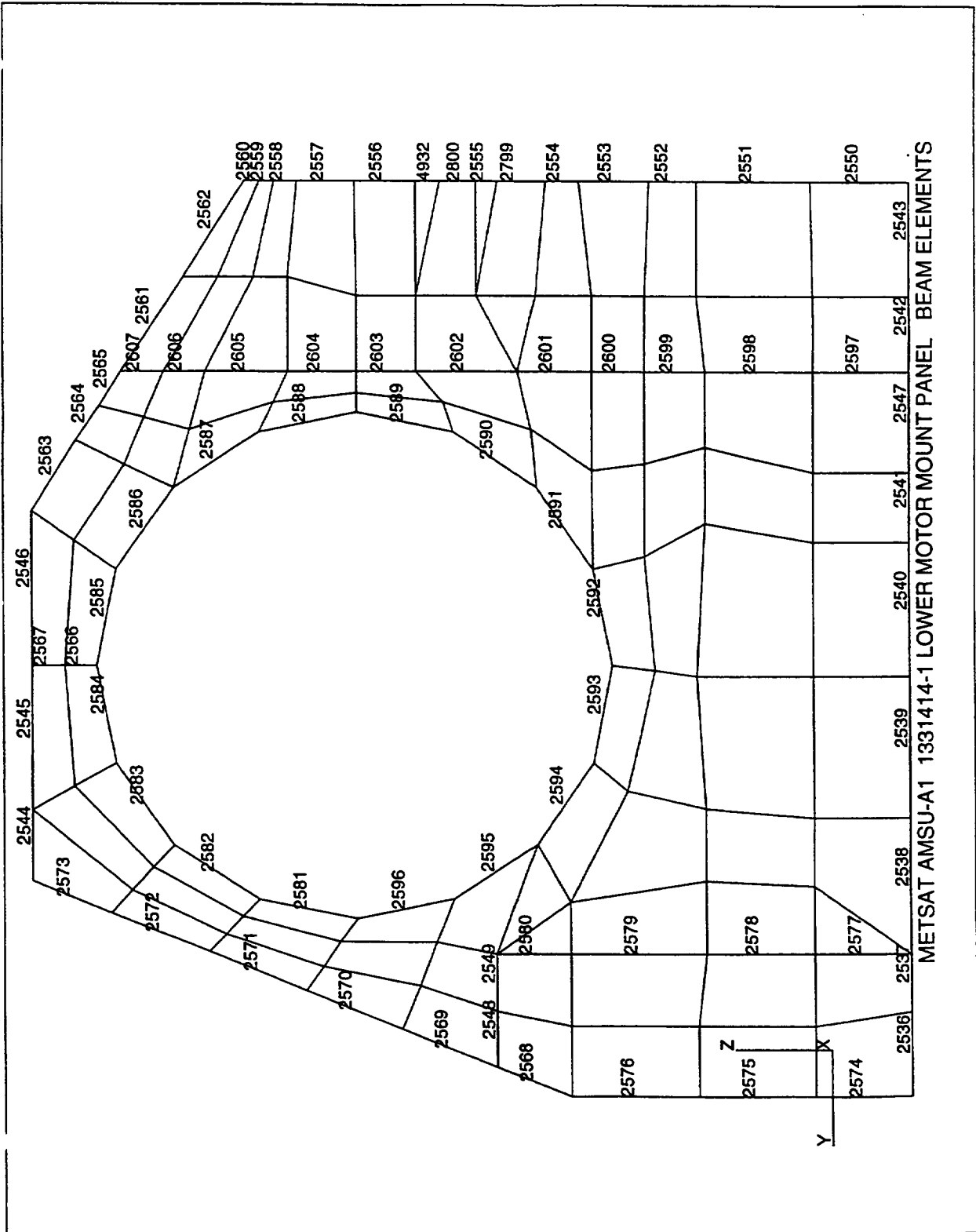

Figure A-9 METSAT AMSU-A1 1331414-1 Lower Motor Mount Panel Beam Elements

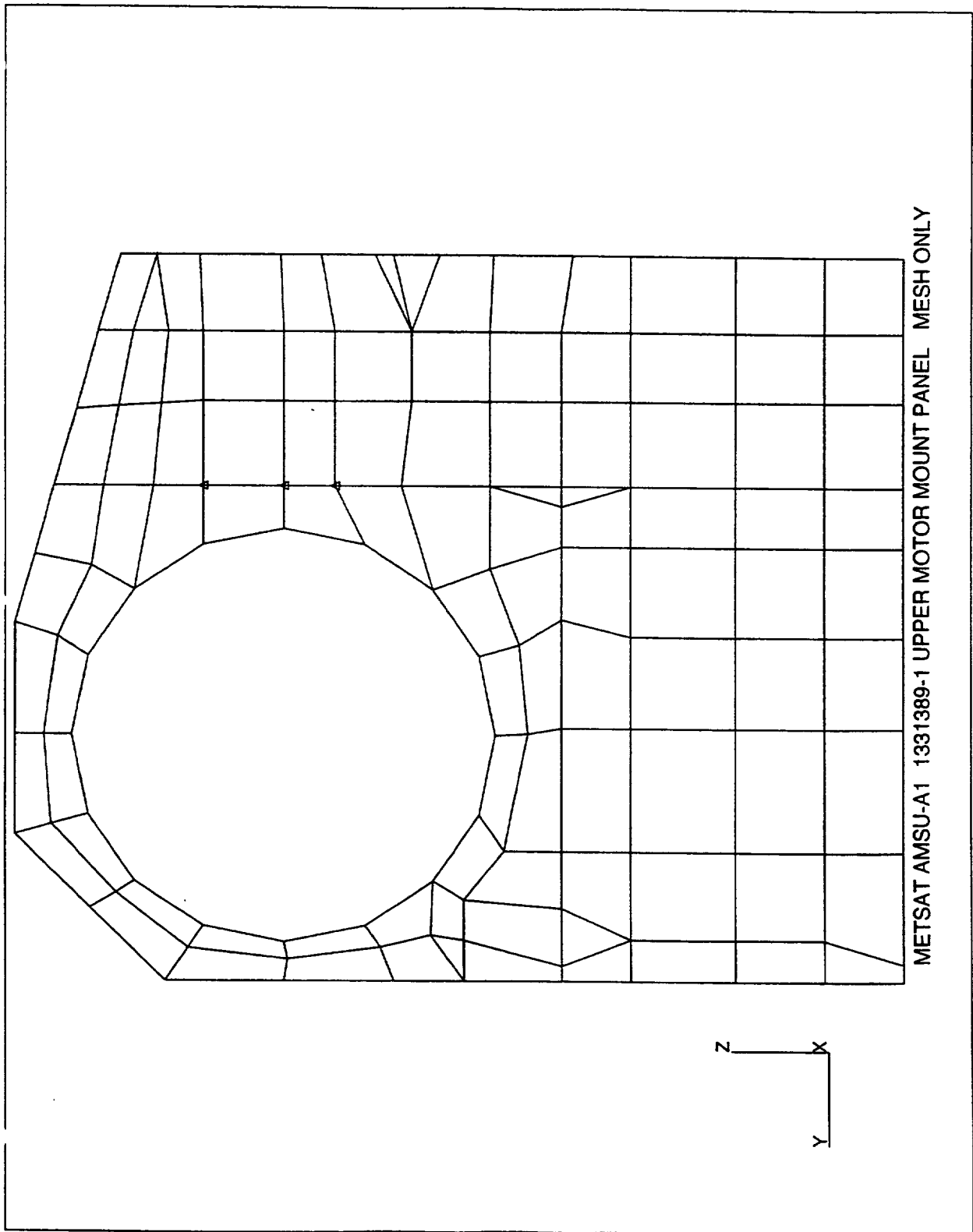

Figure A-10 METSAT AMSU-A1 1331389-1 Upper Motor Mount Panel Mesh Only

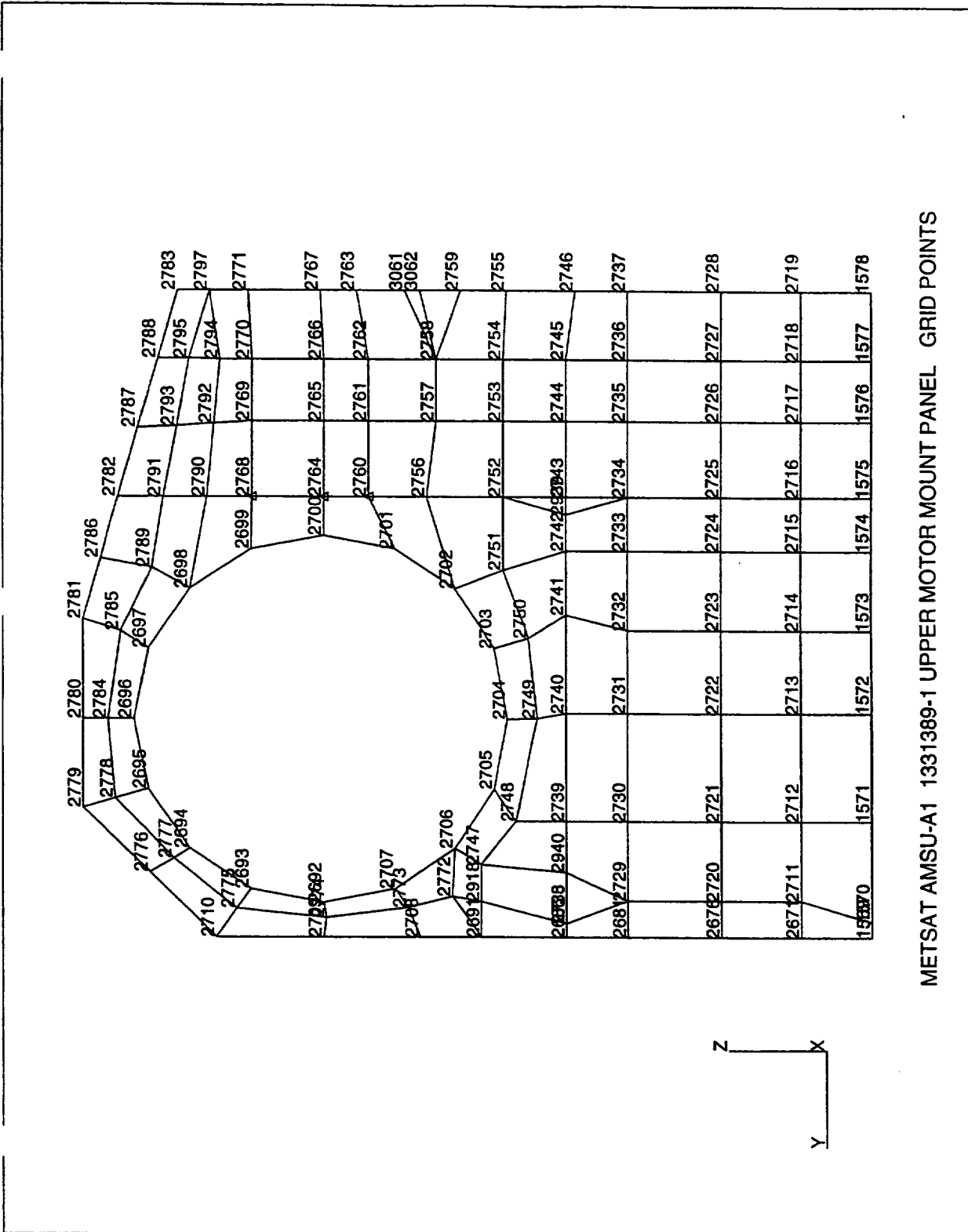

Figure A-11 METSAT AMSU-A1 1331389-1 Upper Motor Mount Panel Grid Points

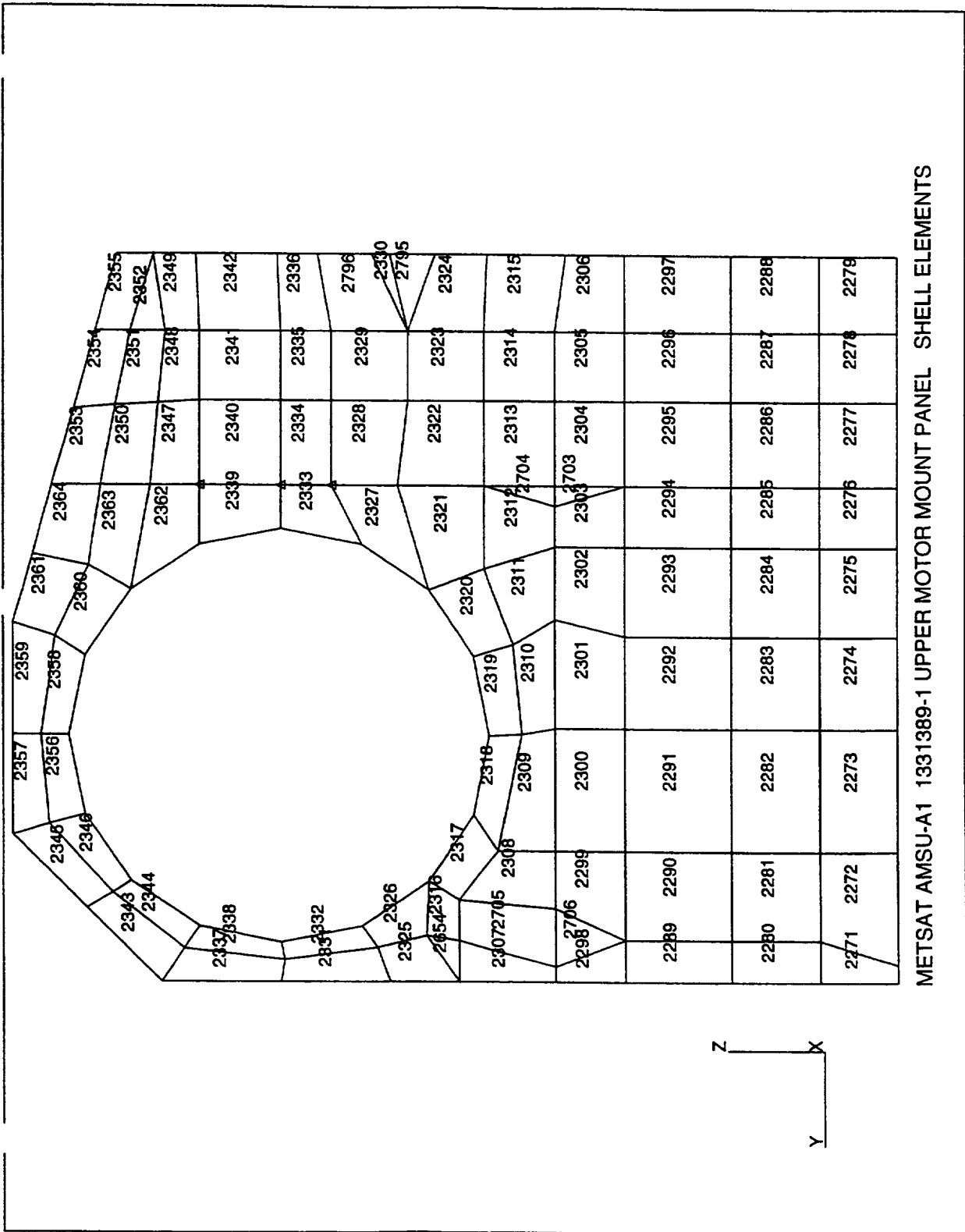

Figure A-12 METSAT AMSU-A1 1331389-1 Upper Motor Mount Panel Shell Elements

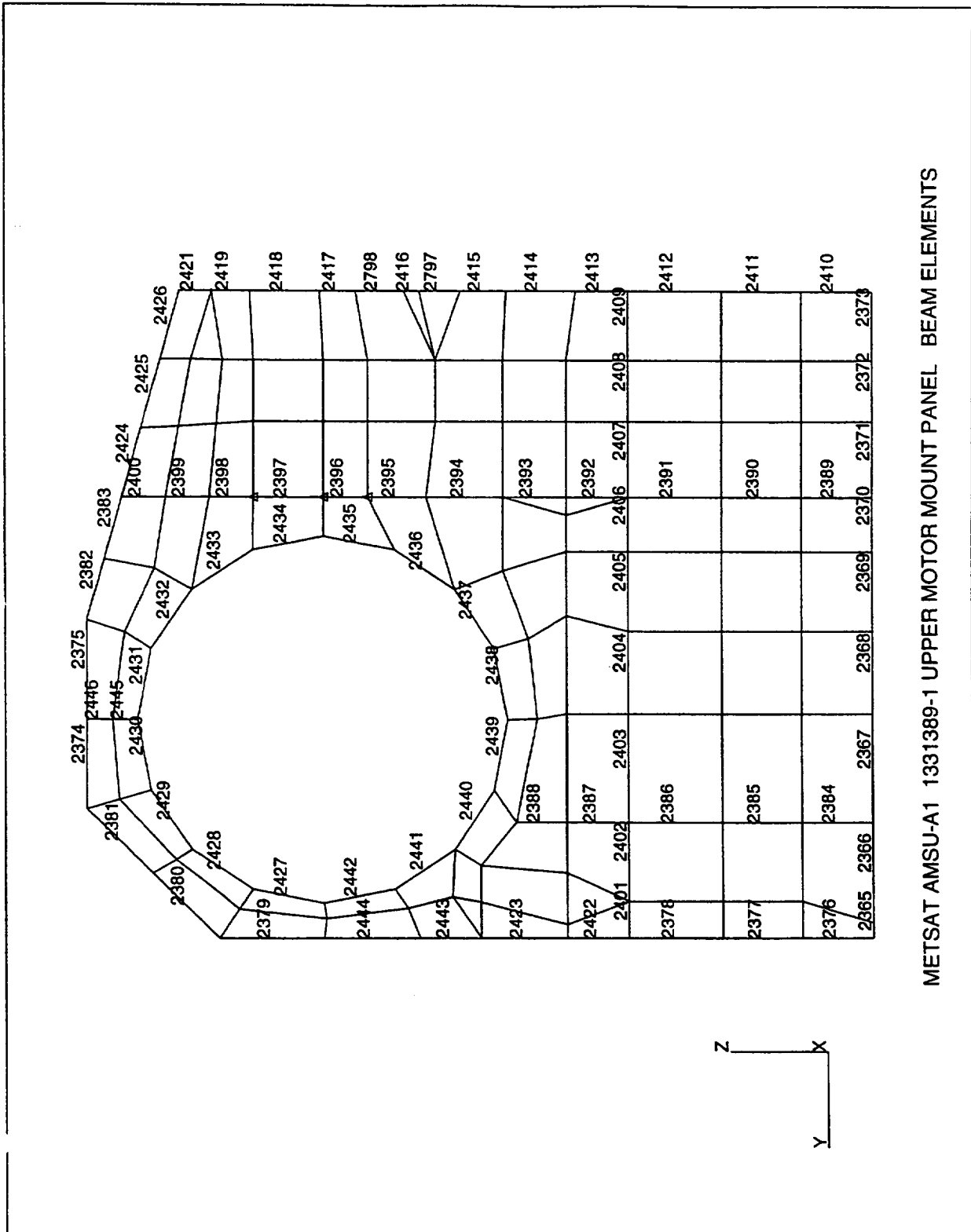

Figure A-13 METSAT AMSU-A1 1331389-1 Upper Motor Mount Panel Beam Elements

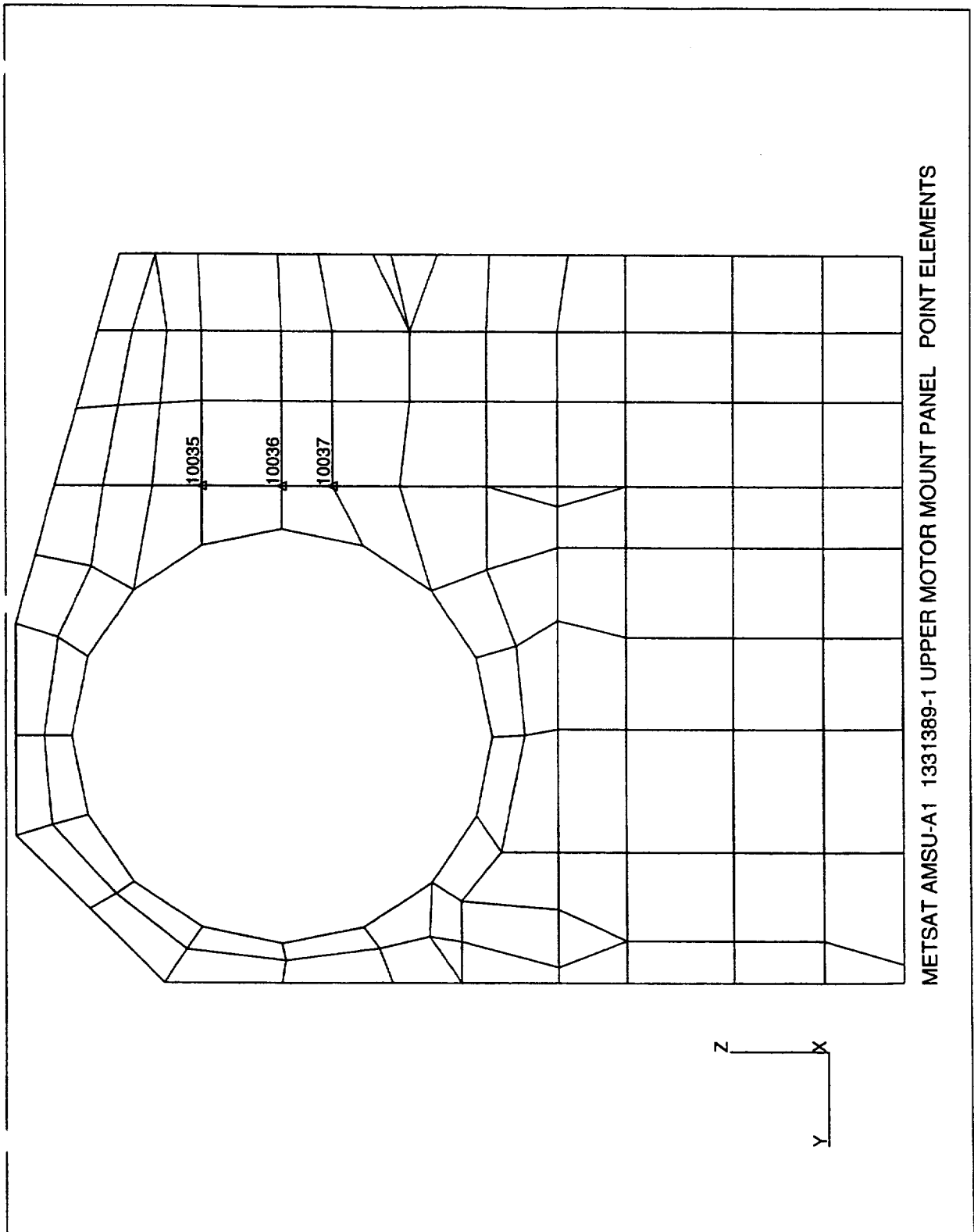

Figure A-14 METSAT AMSU-A1 1331389-1 Upper Motor Mount Panel Point Elements

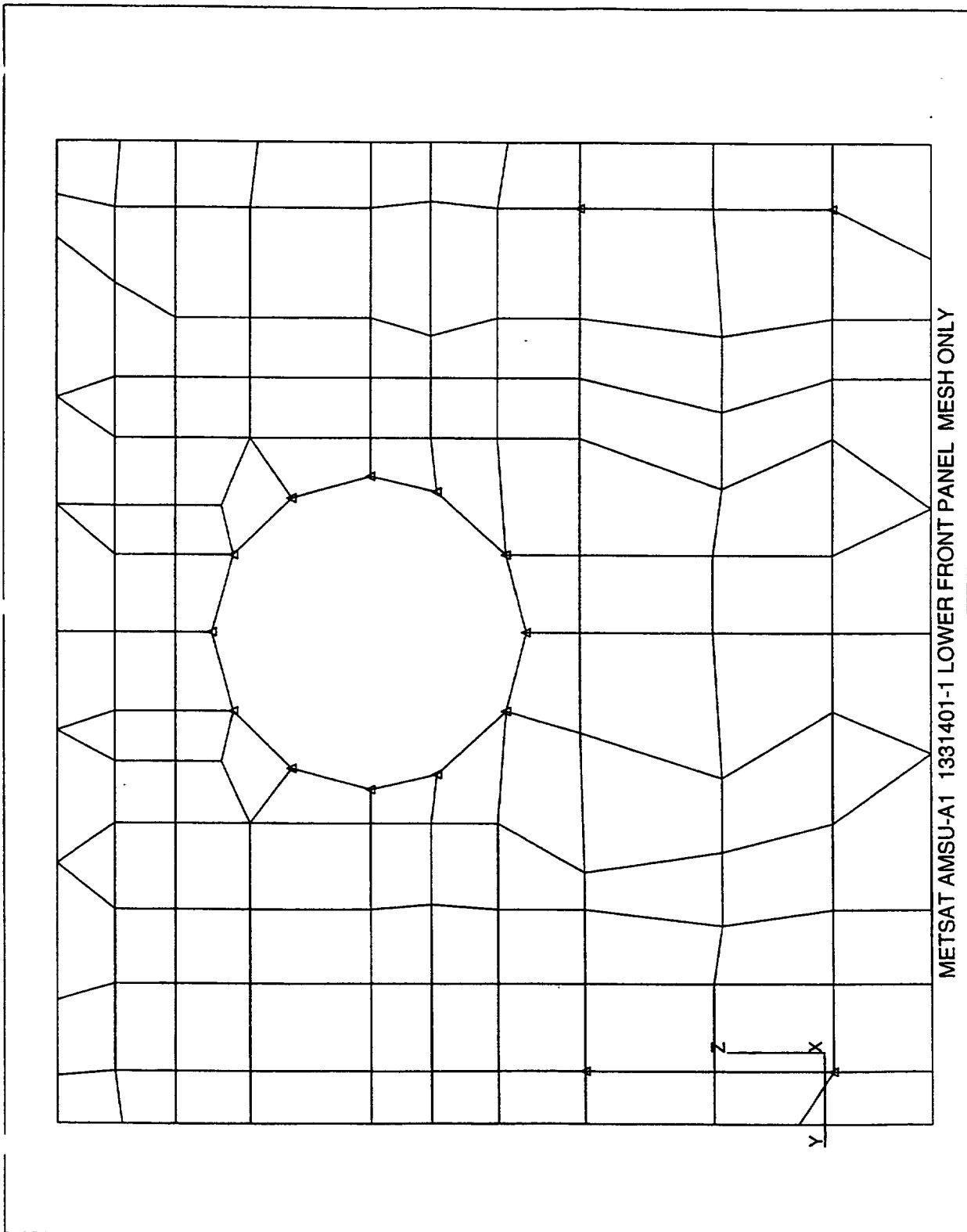

Figure A-15 METSAT AMSU-A1 1331401-1 Lower Front Panel Mesh Only

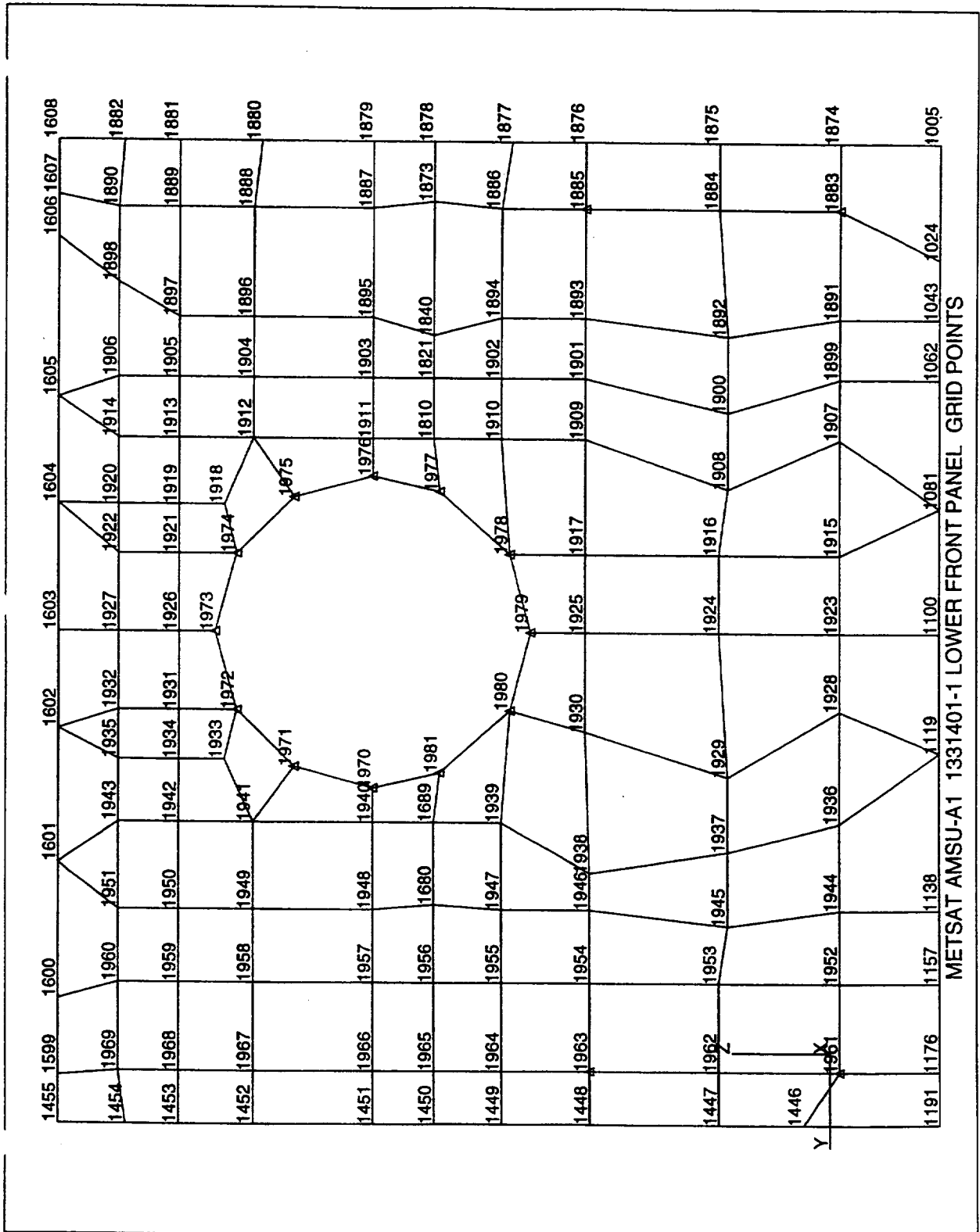

Figure A-16 METSAT AMSU-A1 1331401-1 Lower Front Panel Grid Points

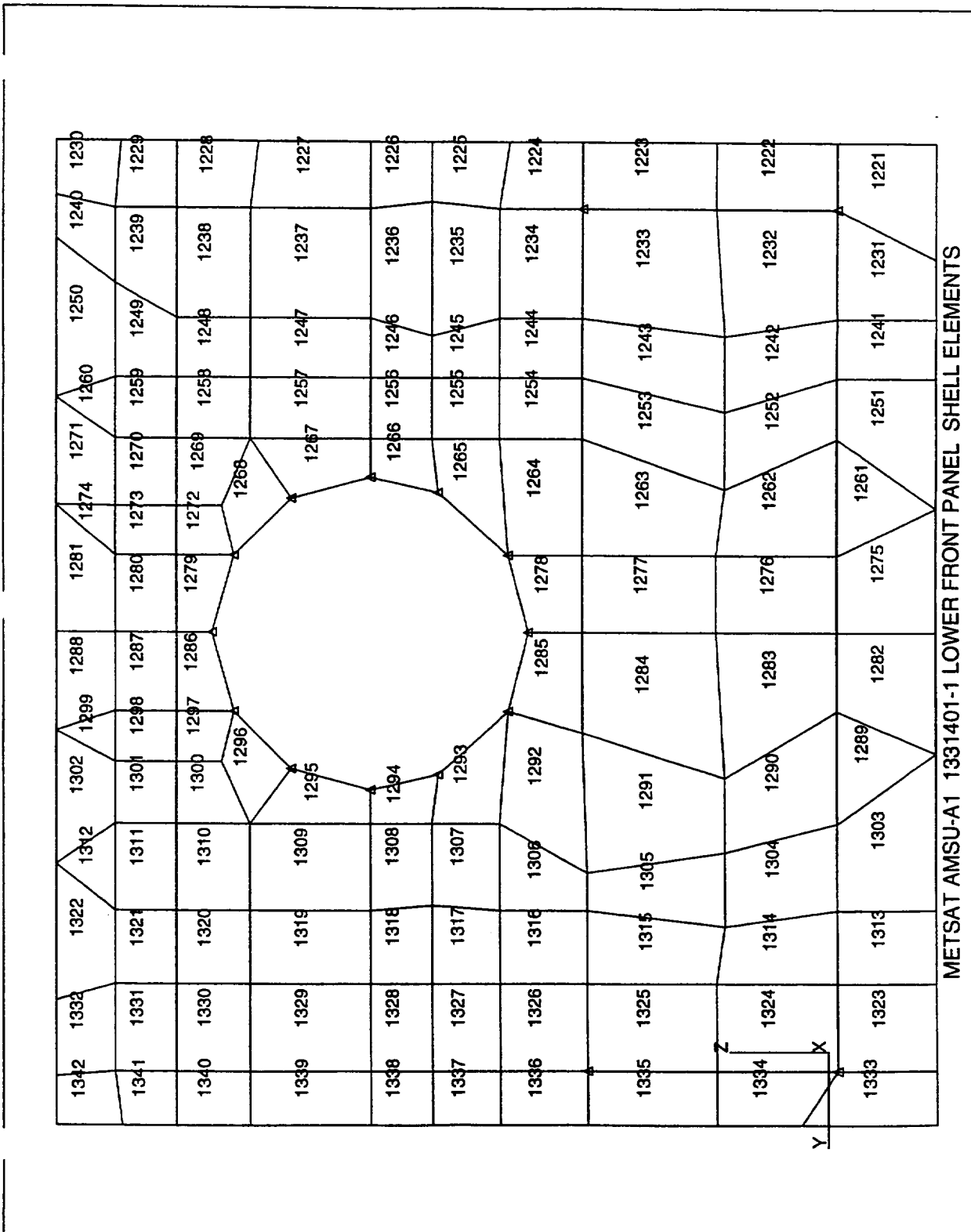

Figure A-17 METSAT AMSU-A1 1331401-1 Lower Front Panel Shell Elements

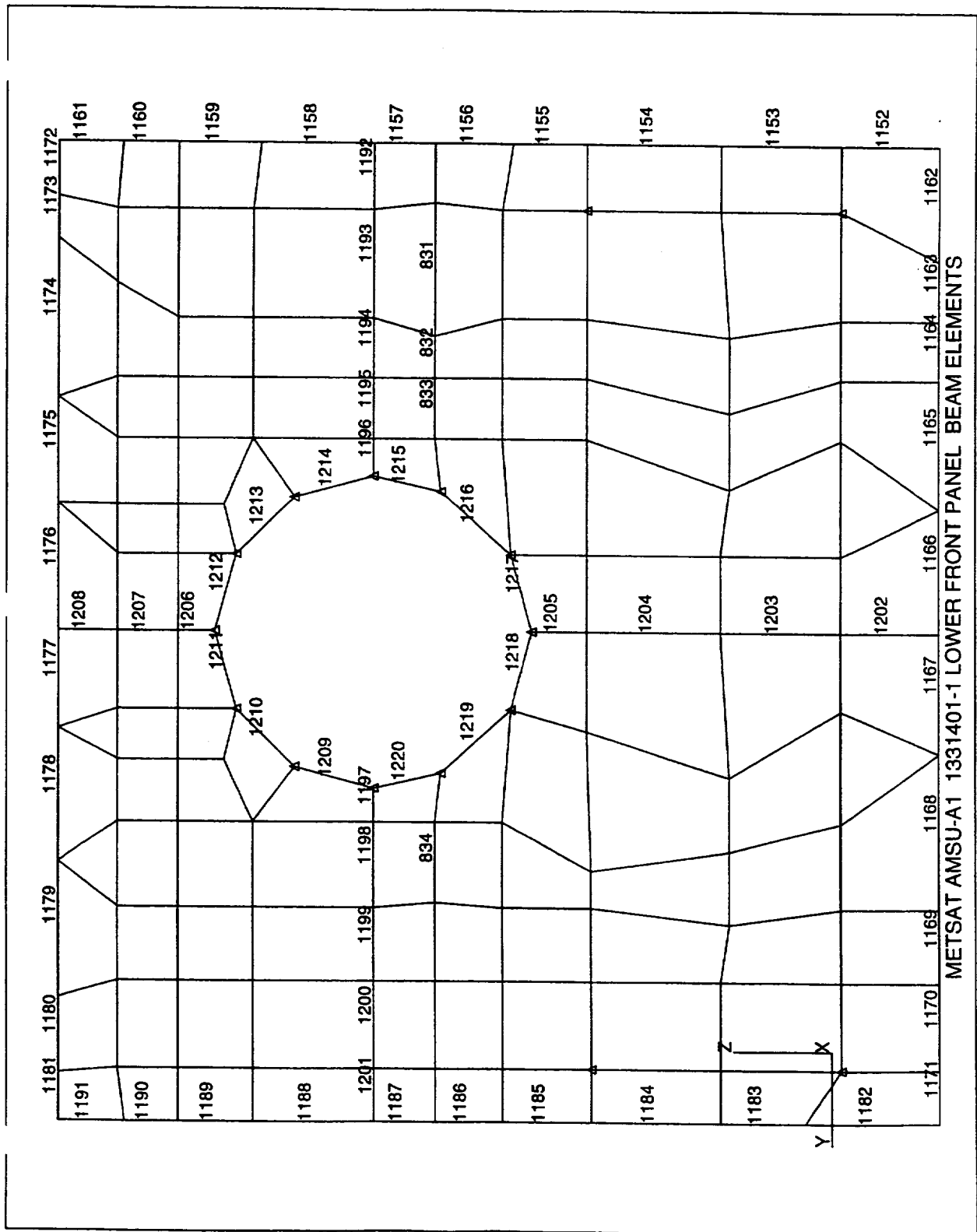

Figure A-18 METSAT AMSU-A1 1331401-1 Lower Front Panel Beam Elements

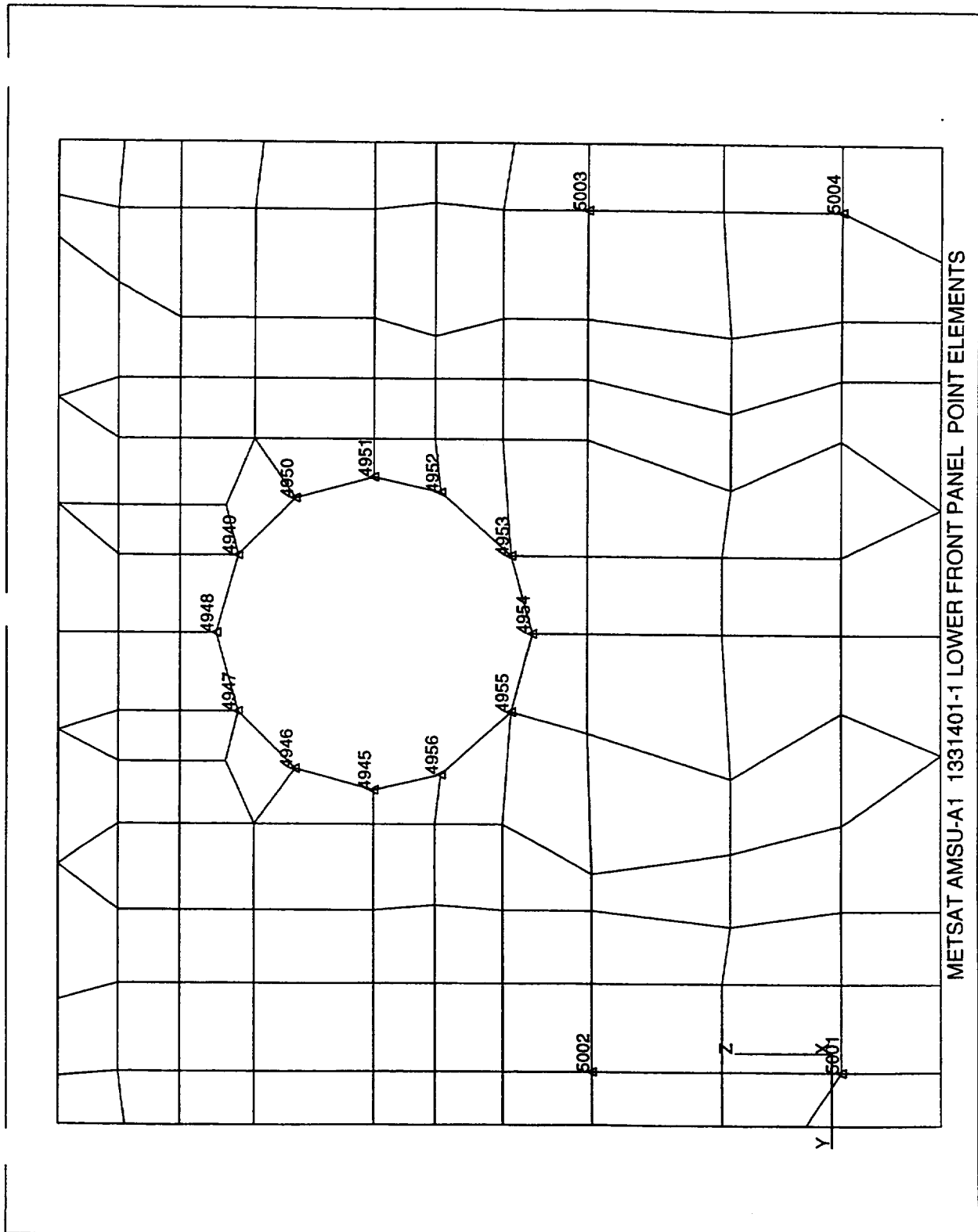

Figure A-19 METSAT AMSU-A1 1331401-1 Lower Front Panel Point Elements

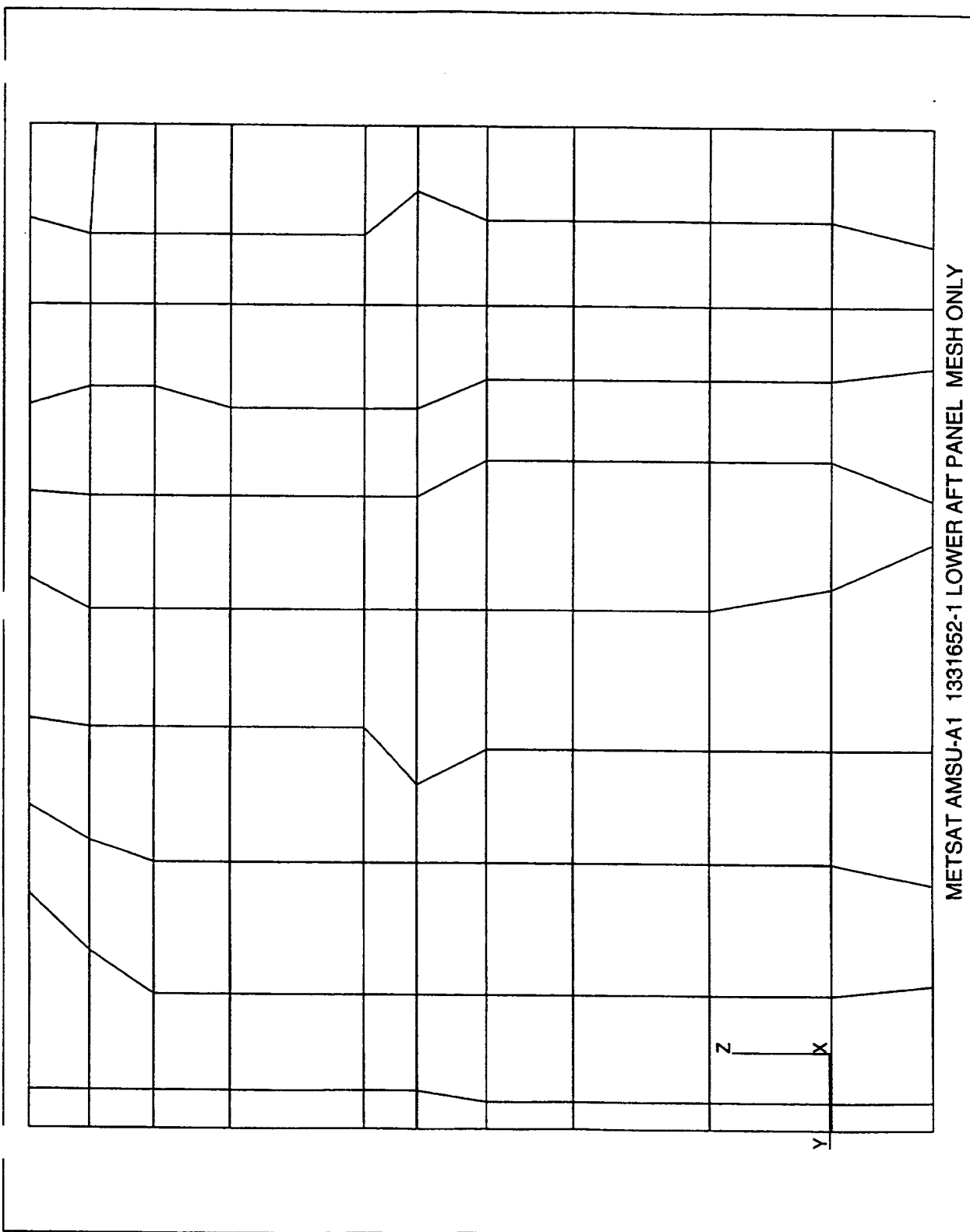

Figure A-20 METSAT AMSU-A1 1331652-1 Lower Aft Panel Mesh Only

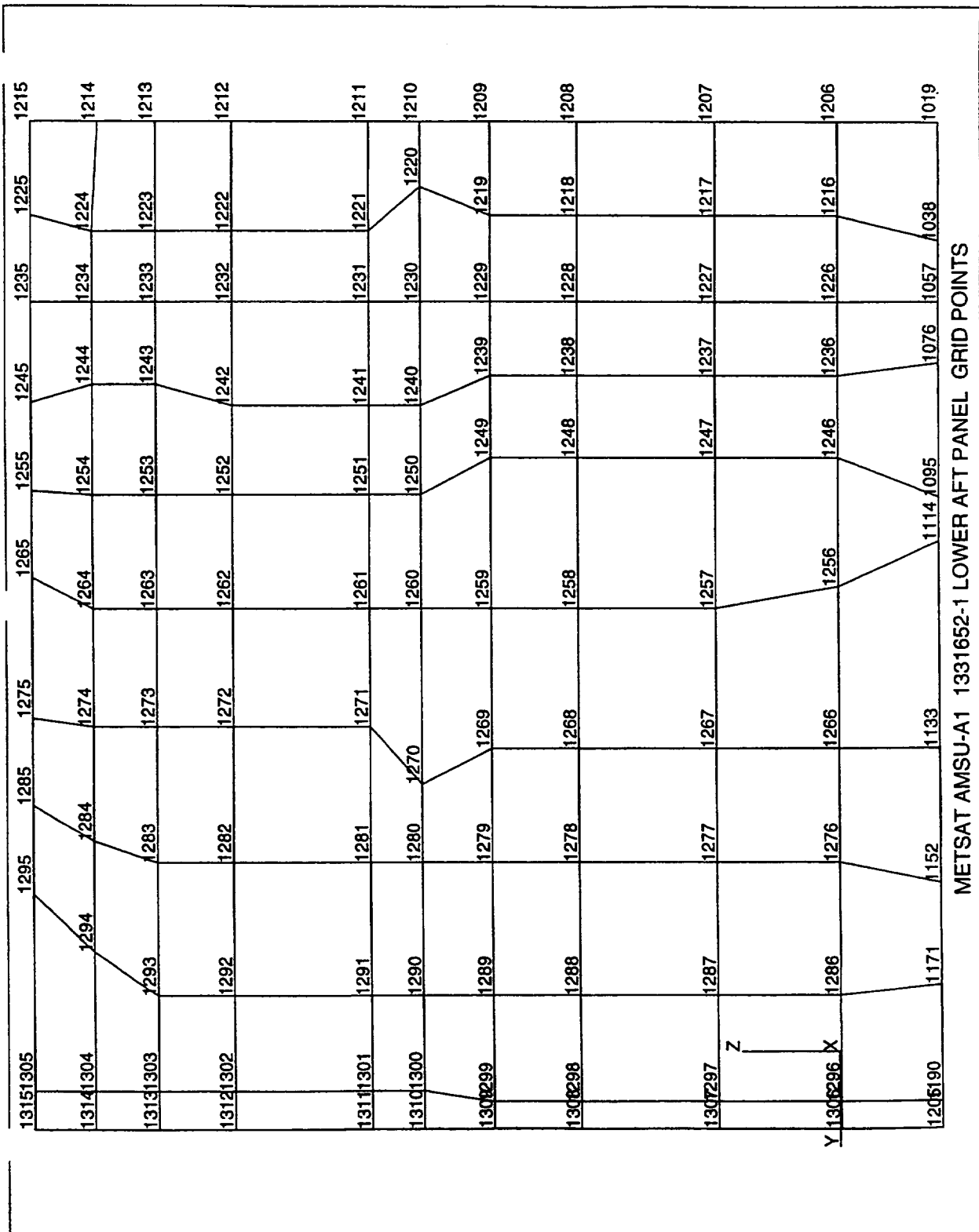

Figure A-21 METSAT AMSU-A1 1331652-1 Lower Aft Panel Grid Points

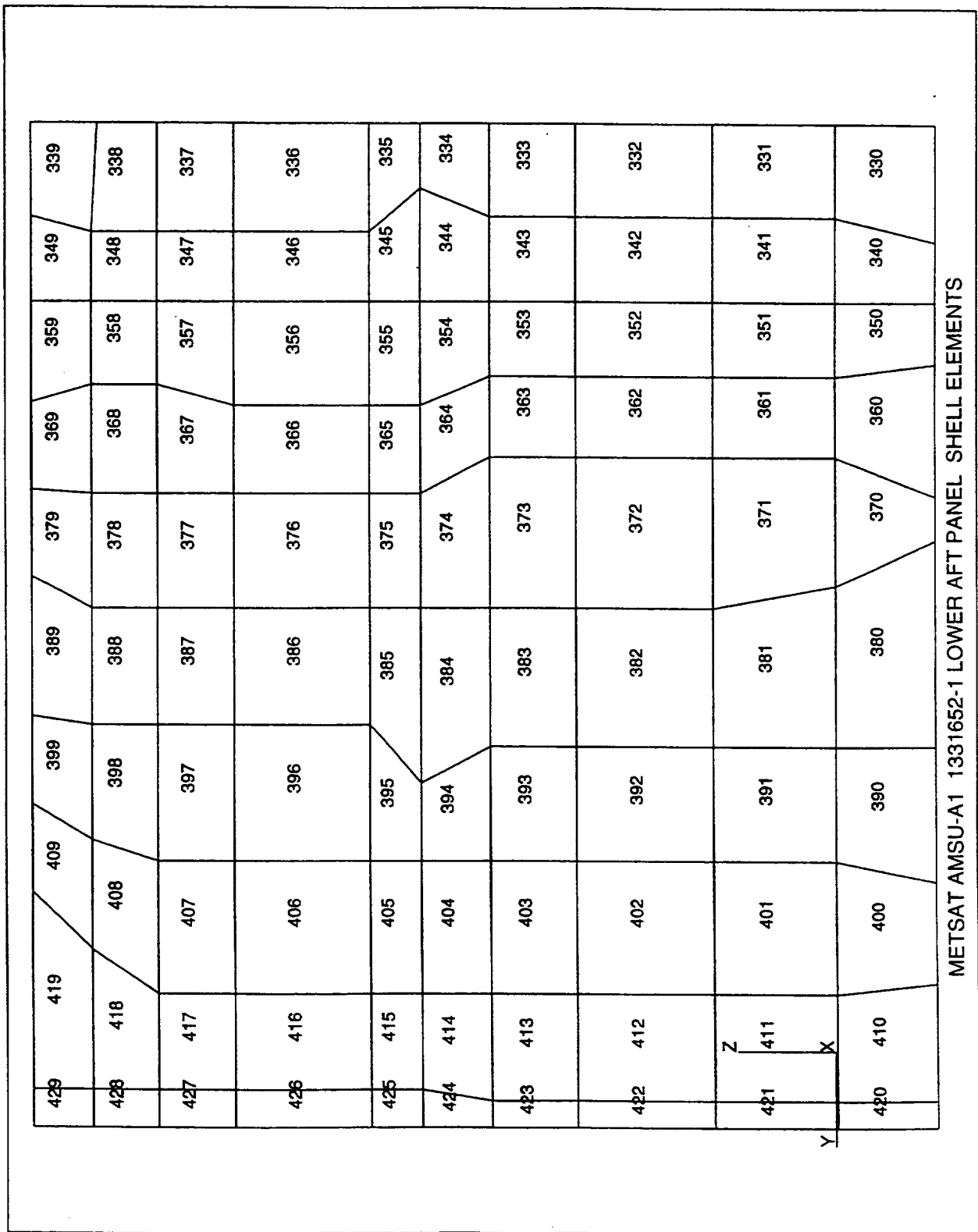

Figure A-22 METSAT AMSU-A1 1331652-1 Lower Aft Panel Shell Elements

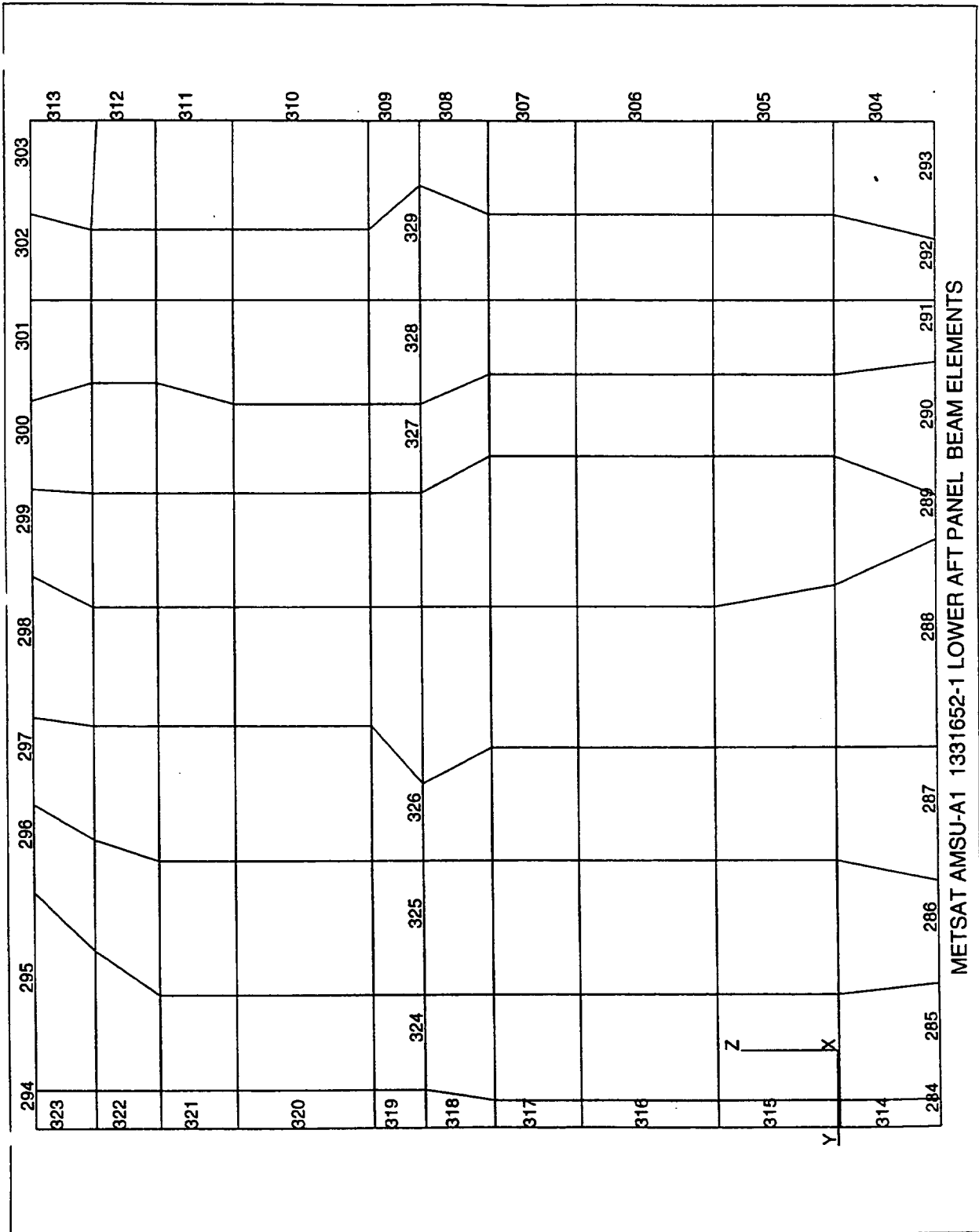

Figure A-23 METSAT AMSU-A1 1331652-1 Lower Aft Panel Beam Elements

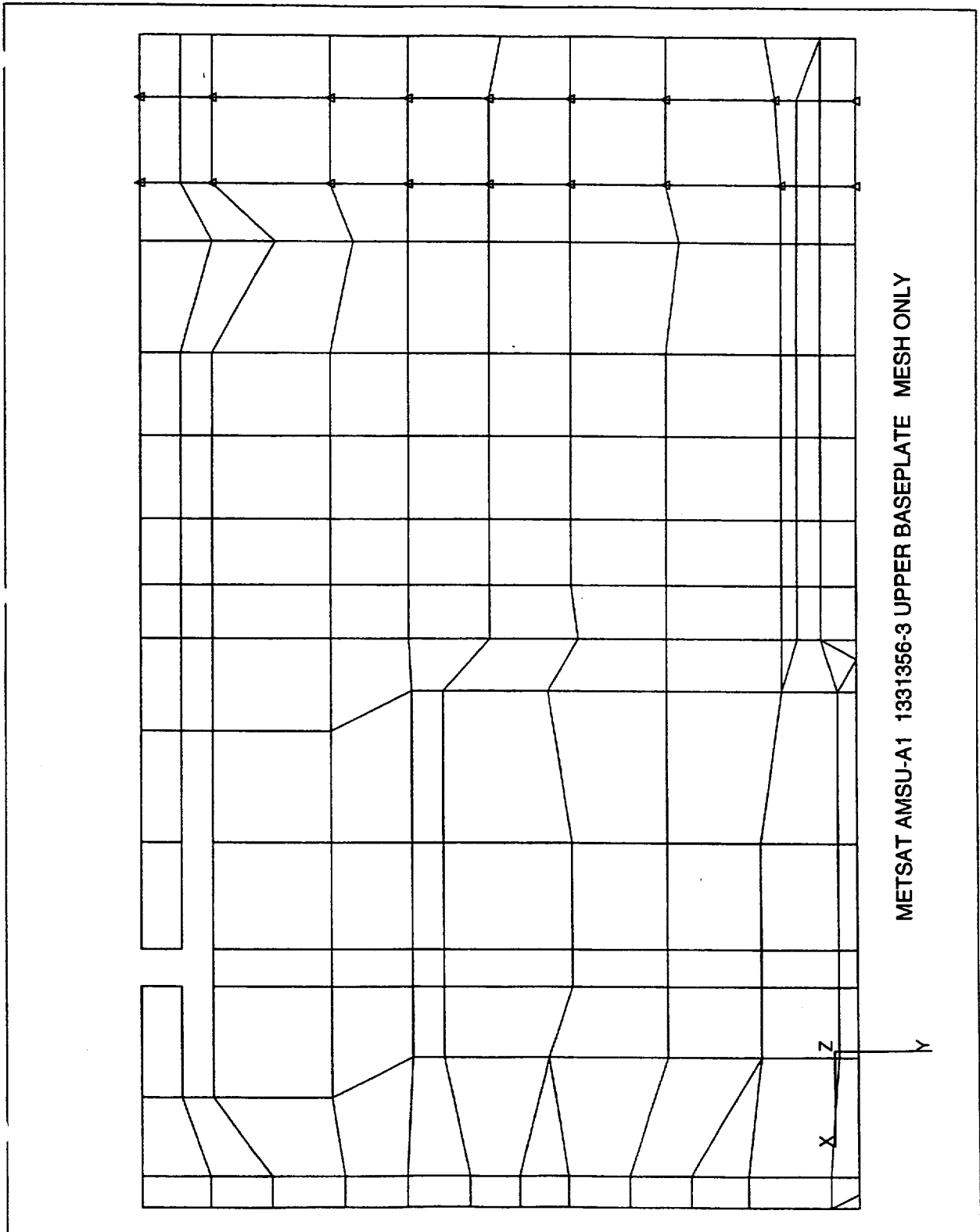

Figure A-24 METSAT AMSU-A1 1331356-3 Upper Baseplate Mesh Only

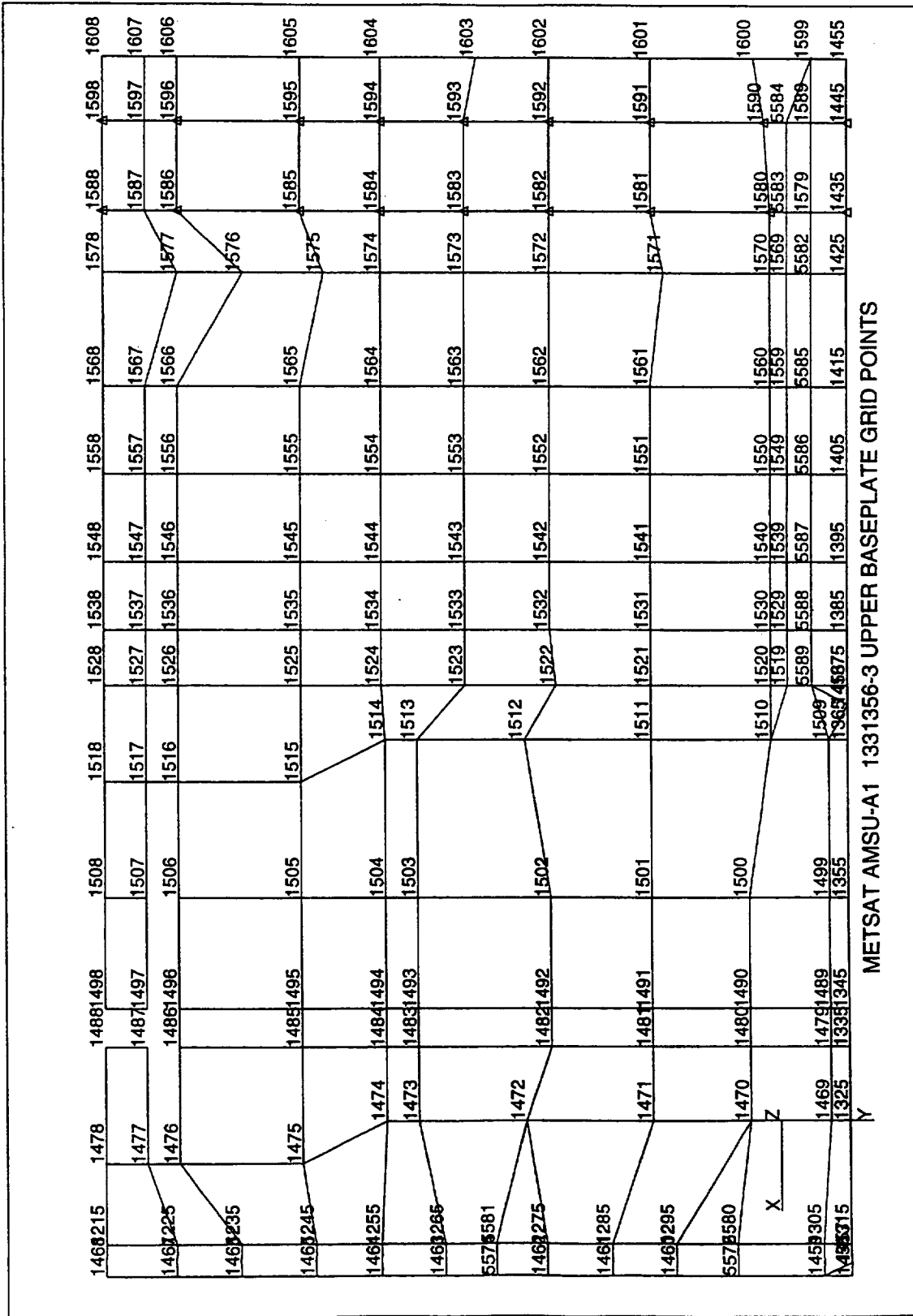

Figure A-25 METSAT AMSU-A1 1331356-3 Upper Baseplate Grid Points

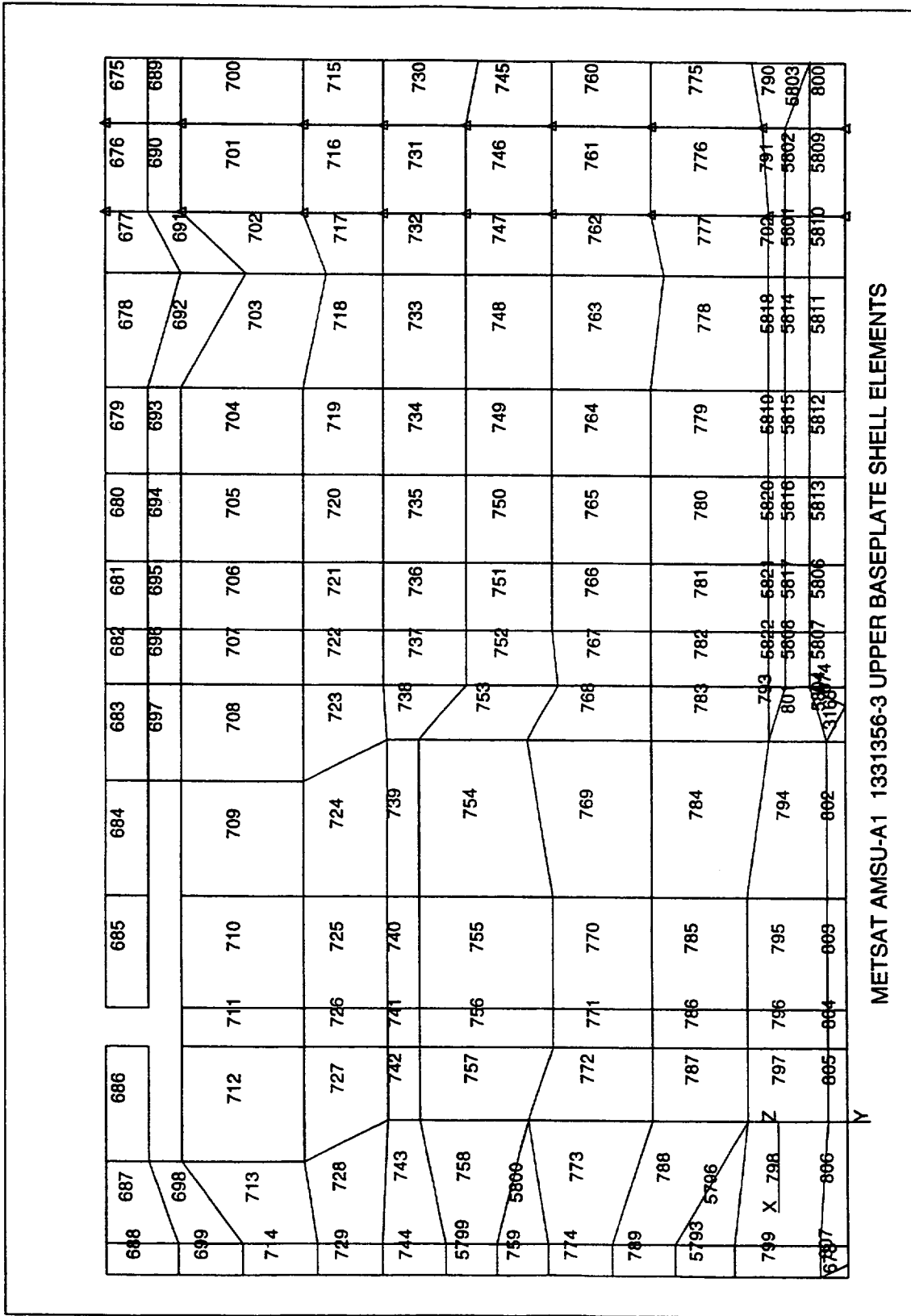

Figure A-26 METSAT AMSU-A1 1331356-3 Upper Baseplate Shell Elements

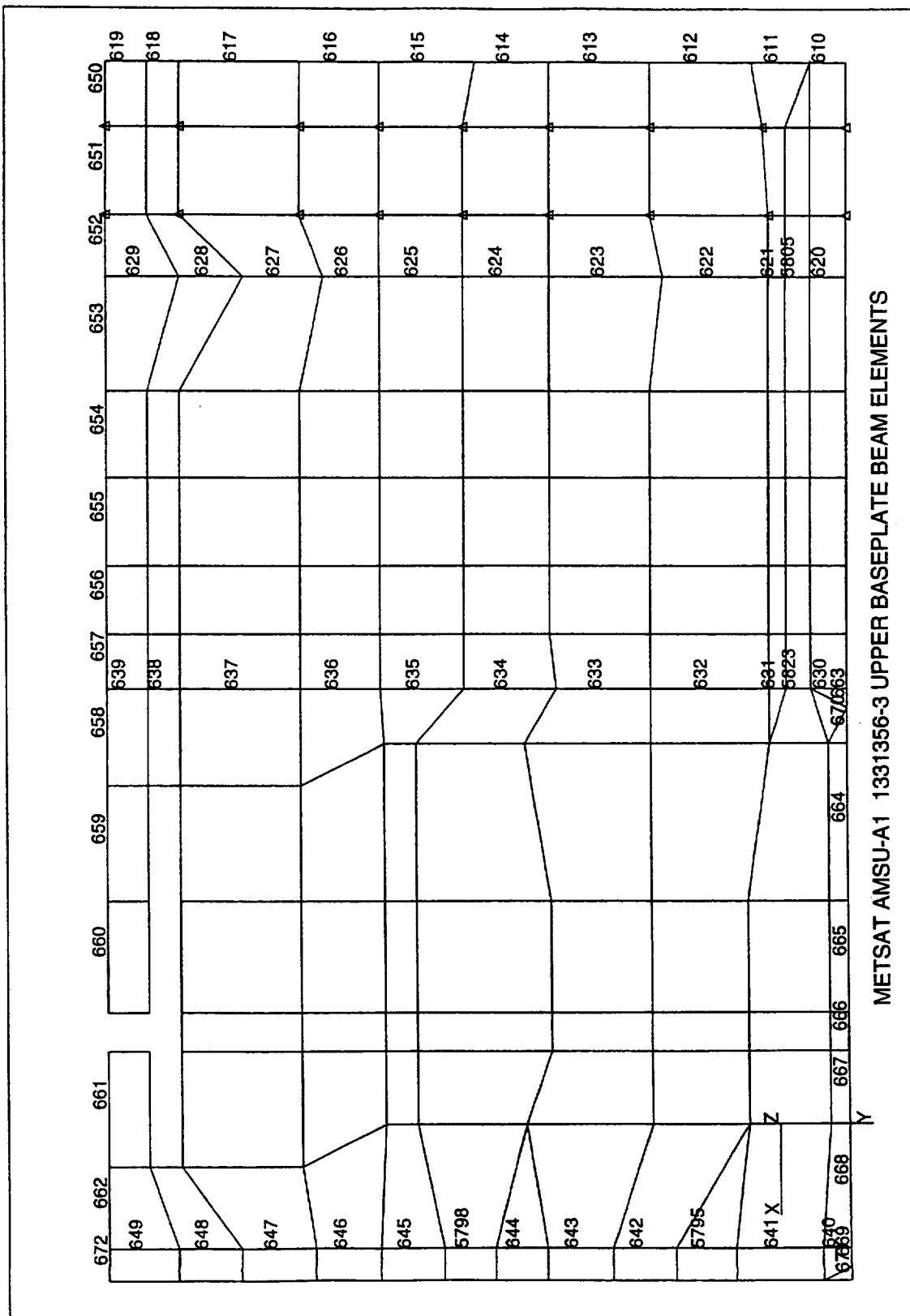

Figure A-27 METSAT AMSU-A1 1331356-3 Upper Baseplate Beam Elements

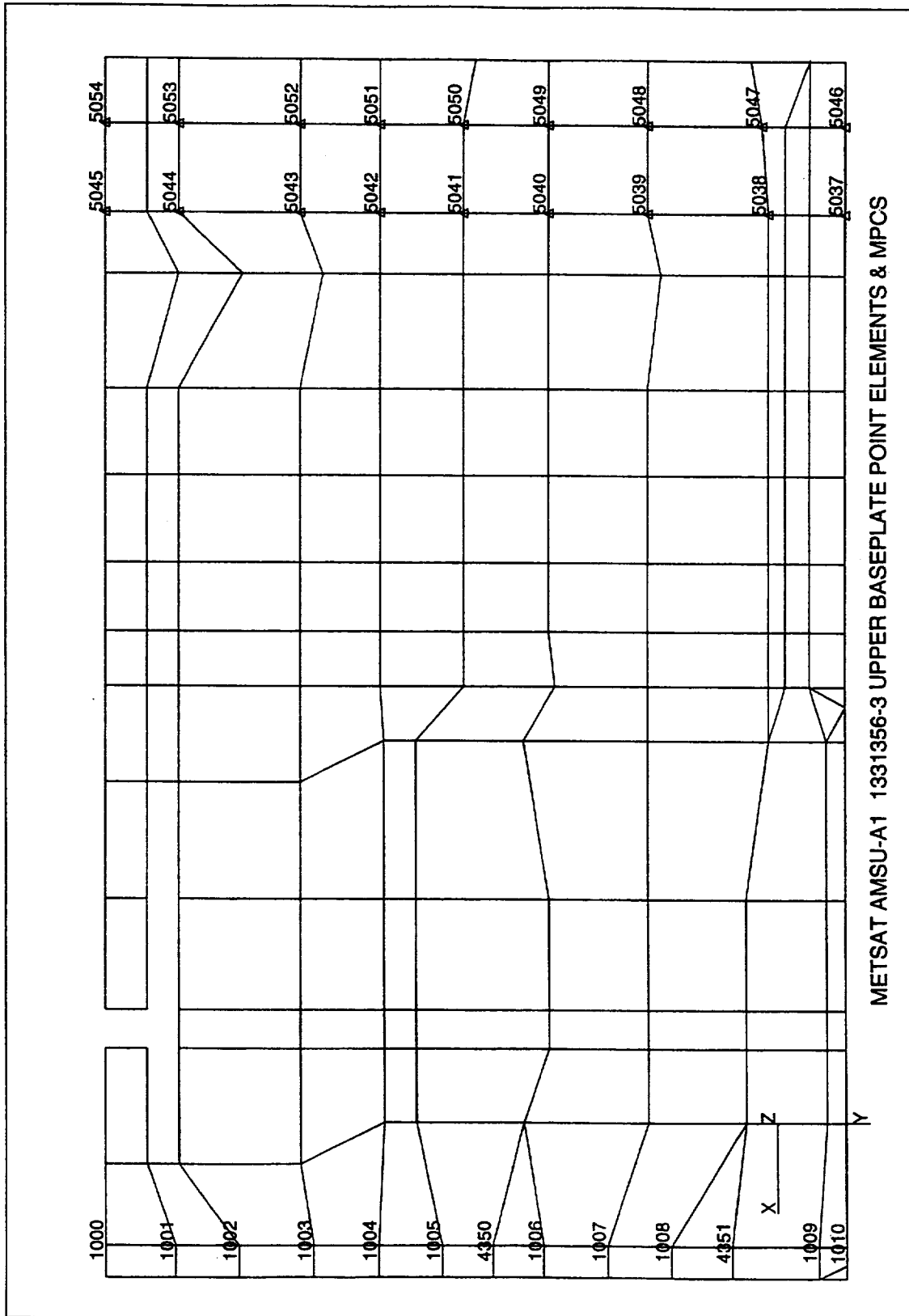

Figure A-28 METSAT AMSU-A1 1331356-3 Upper Baseplate Point Elements & MPCs

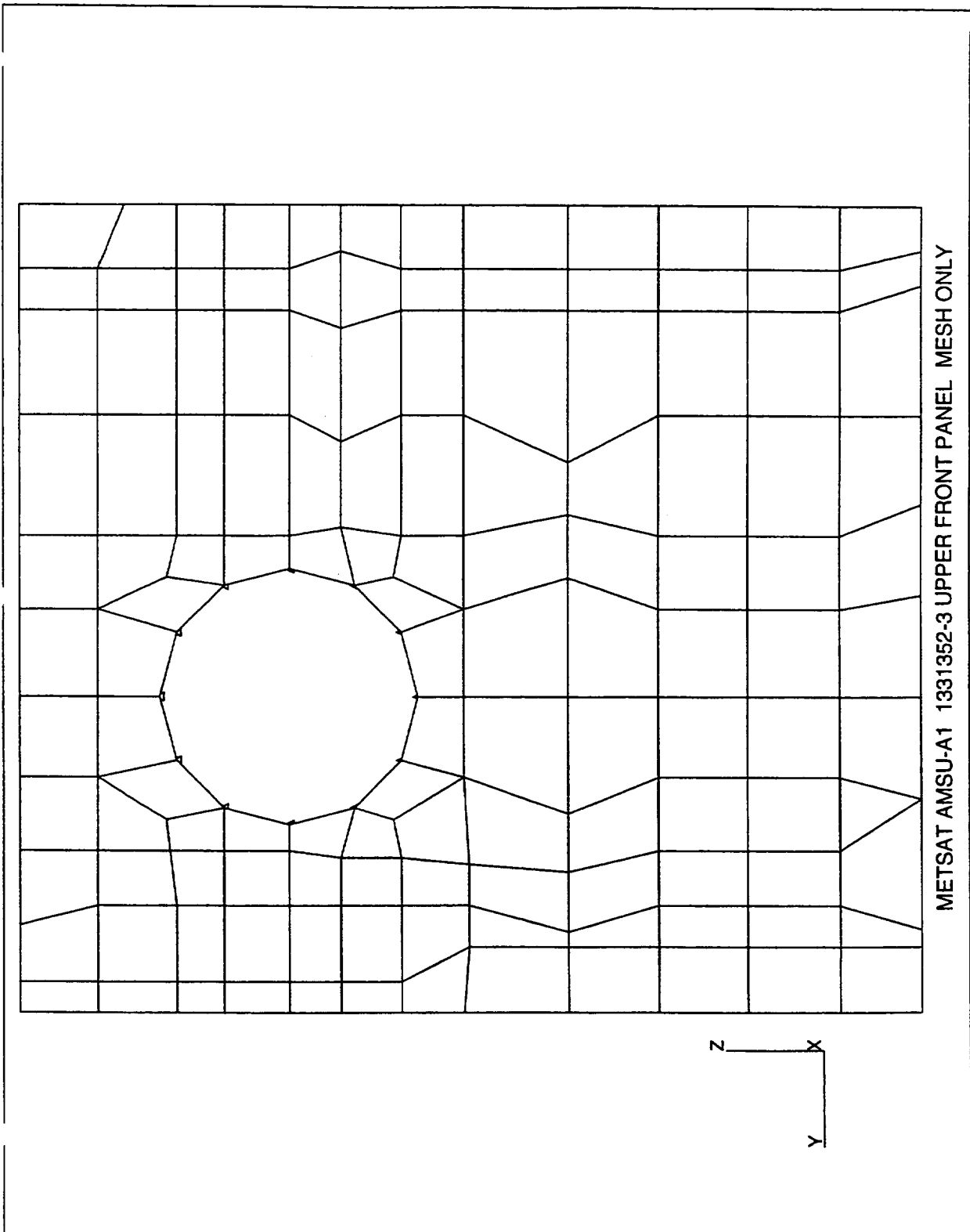
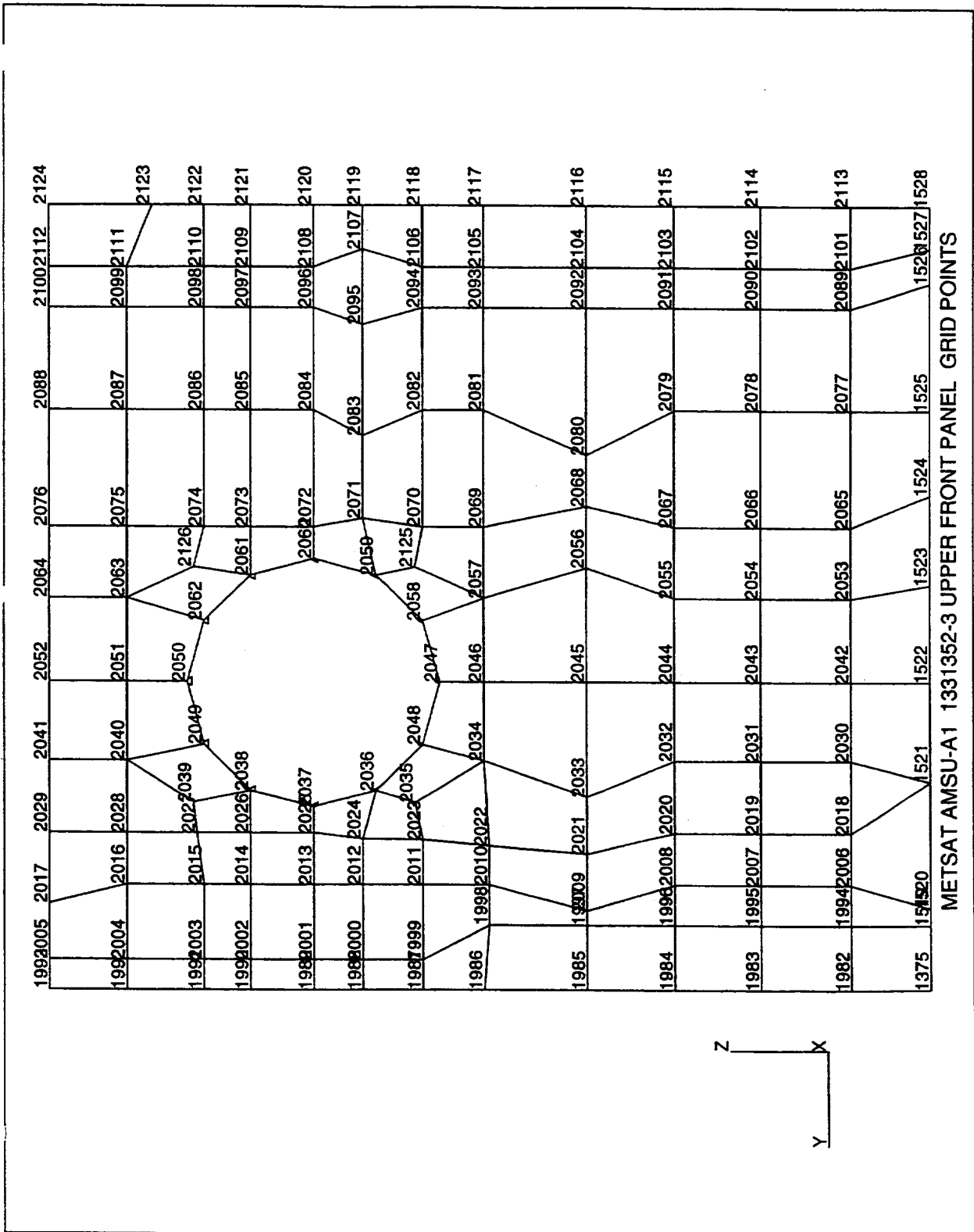

Figure A-29 METSAT AMSU-A1 1331352-3 Upper Front Panel Mesh Only



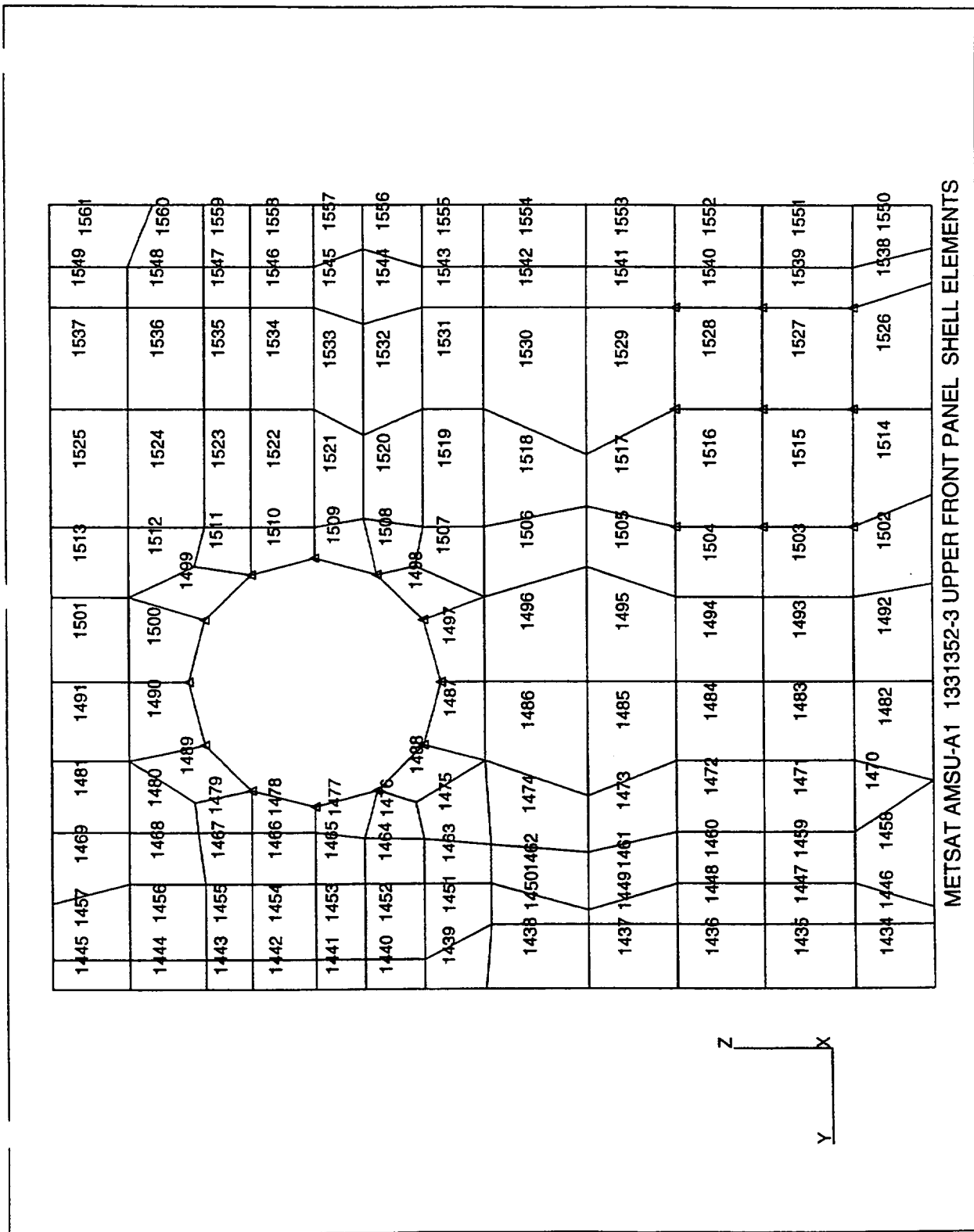

Figure A-31 METSAT AMSU-A1 1331352-3 Upper Front Panel Shell Elements

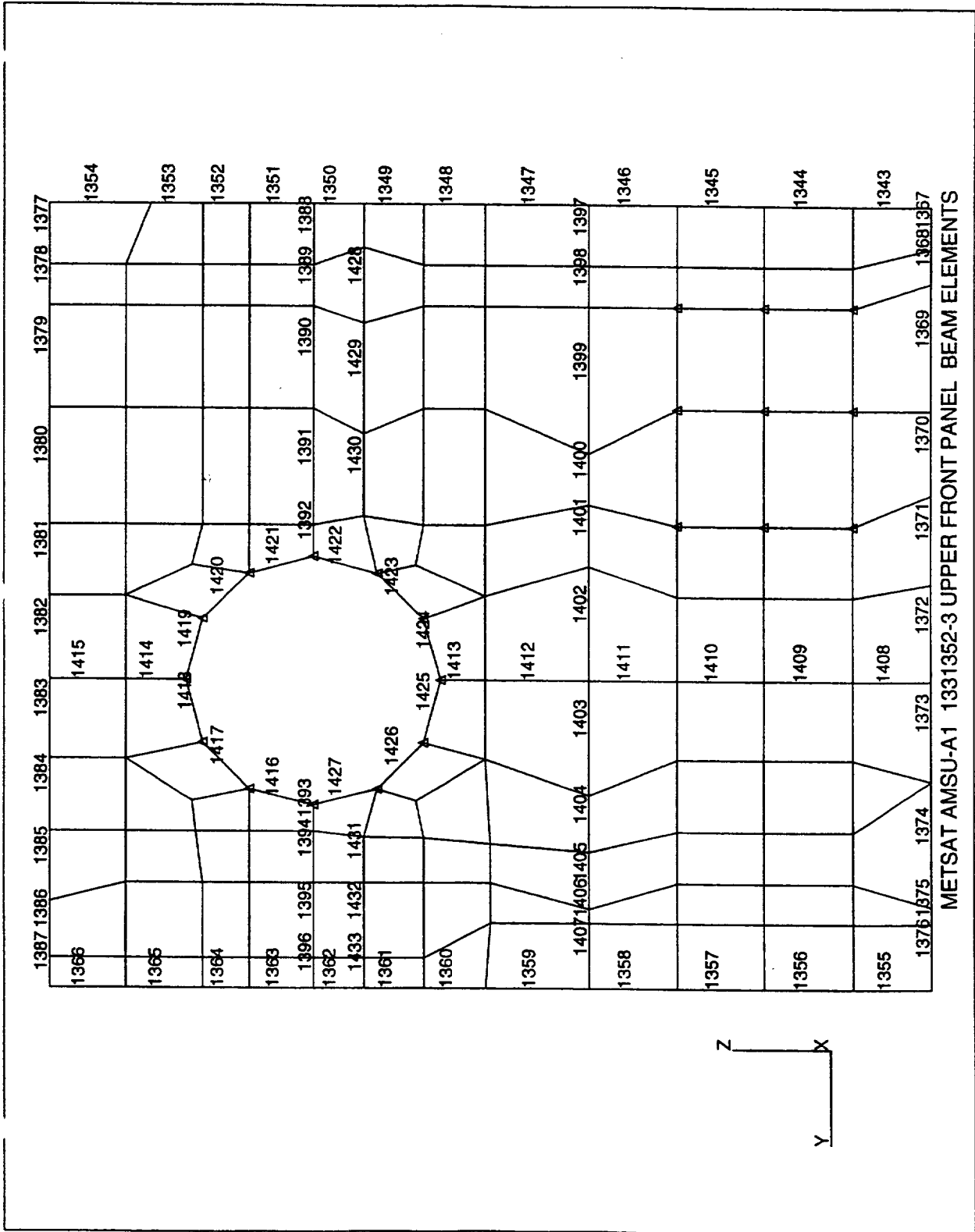

Figure A-32 METSAT AMSU-A1 1331352-3 Upper Front Panel Beam Elements

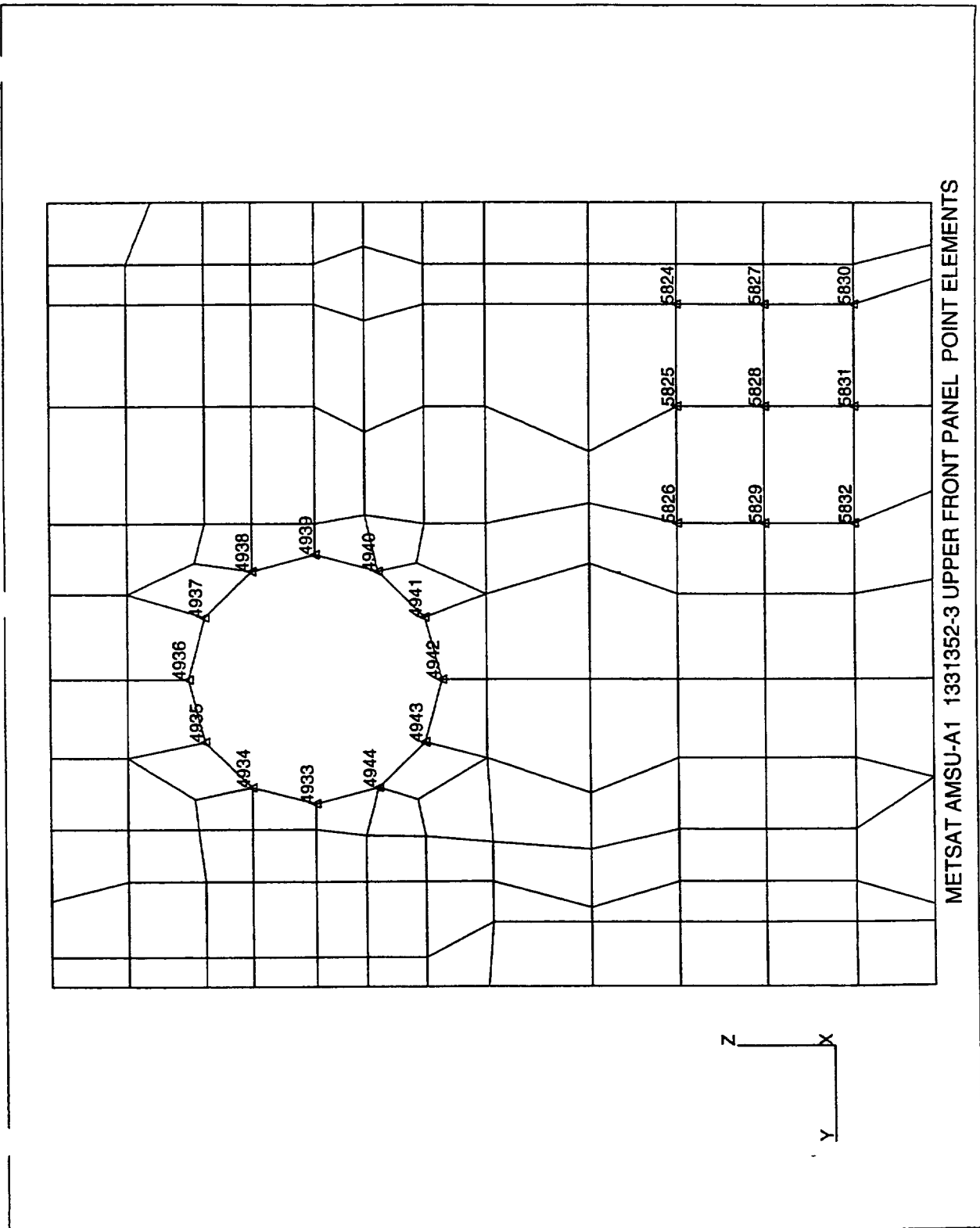

Figure A-33 METSAT AMSU-A1 1331352-3 Upper Front Panel Point Elements

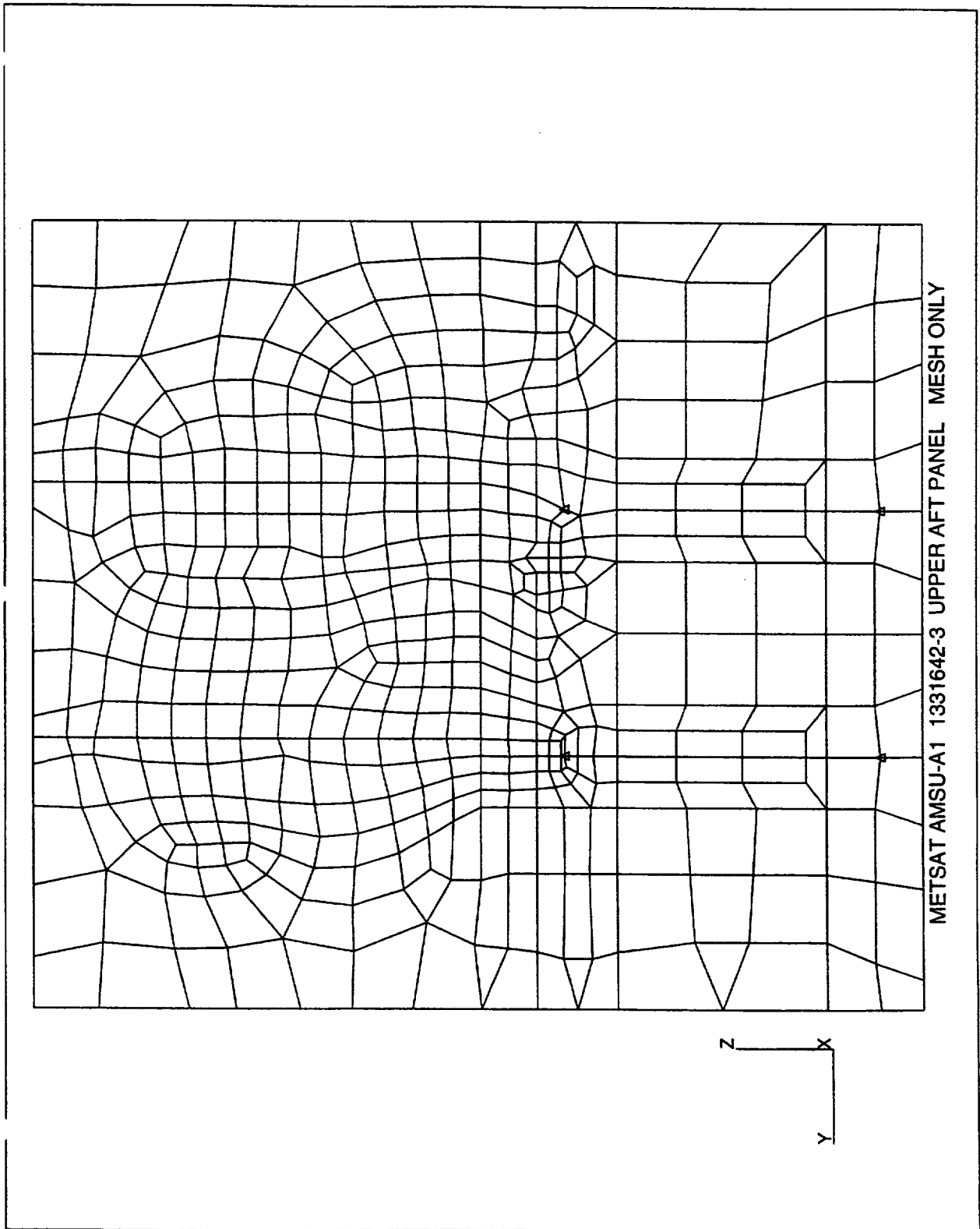

Figure A-34 METSAT AMSU-A1 1331642-3 Upper Aft Panel Mesh Only

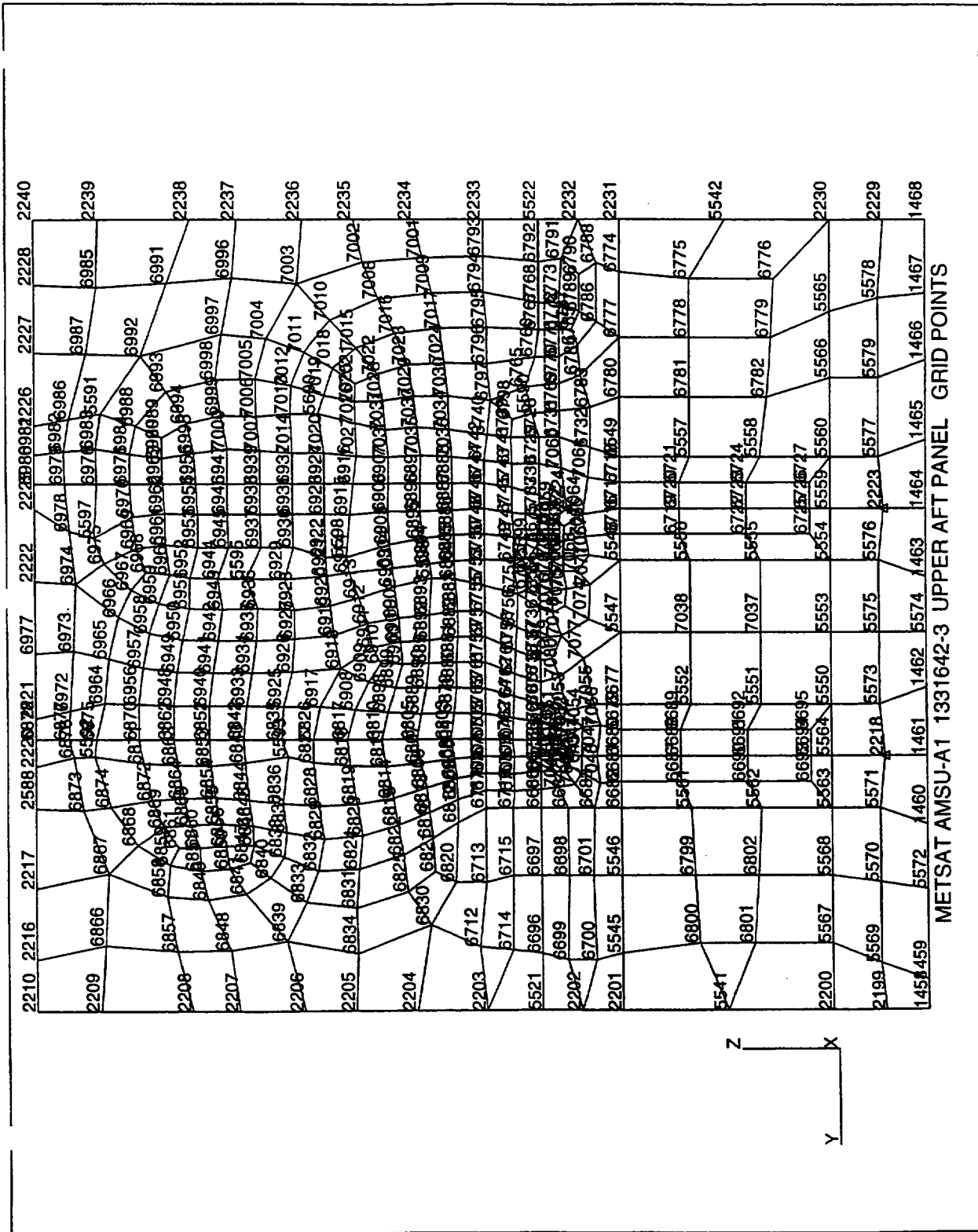

Figure A-35 METSAT AMSU-A1 1331642-3 Upper Aft Panel Grid Points

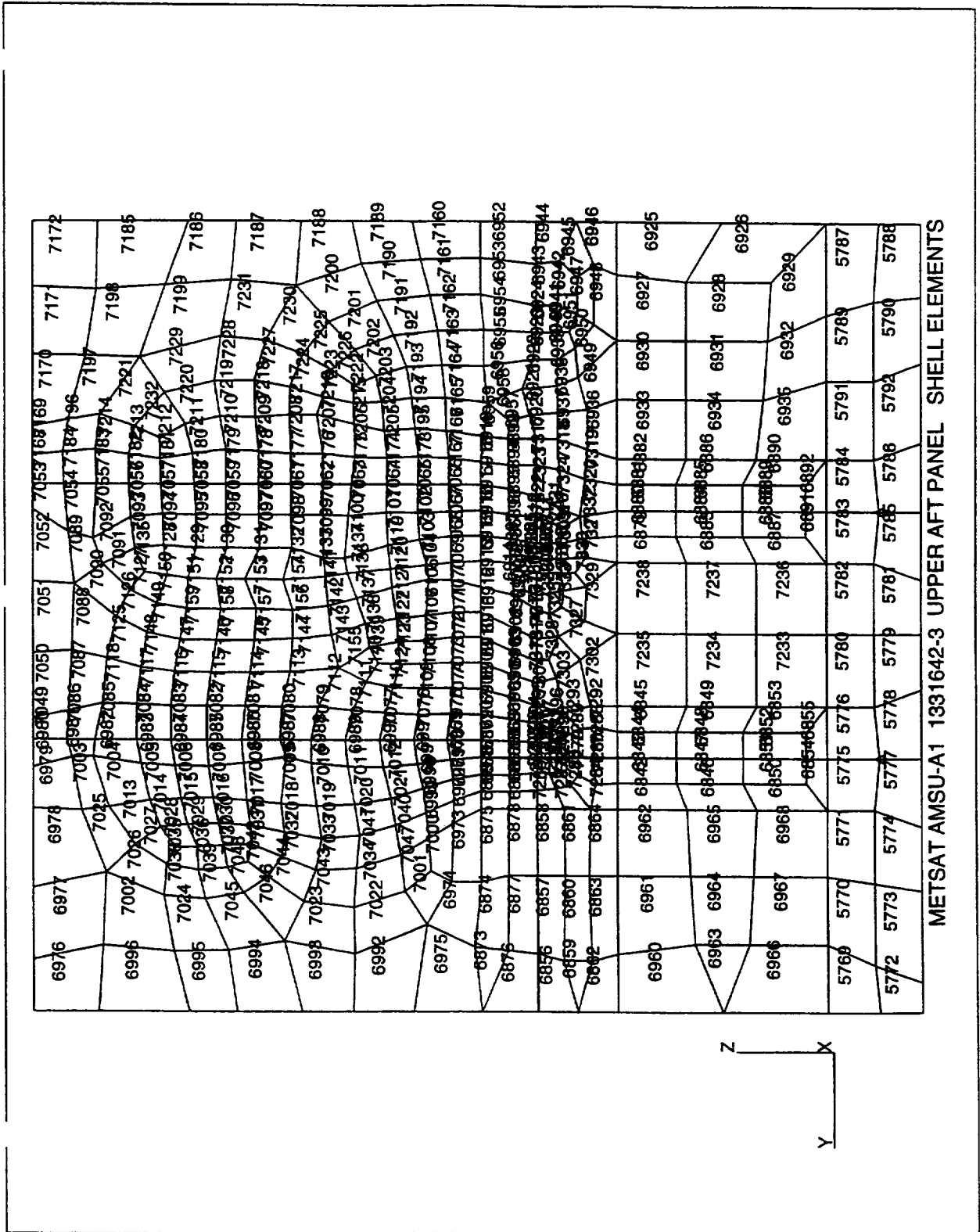

Figure A-36 METSAT AMSU-A1 1331642-3 Upper Aft Panel Shell Elements

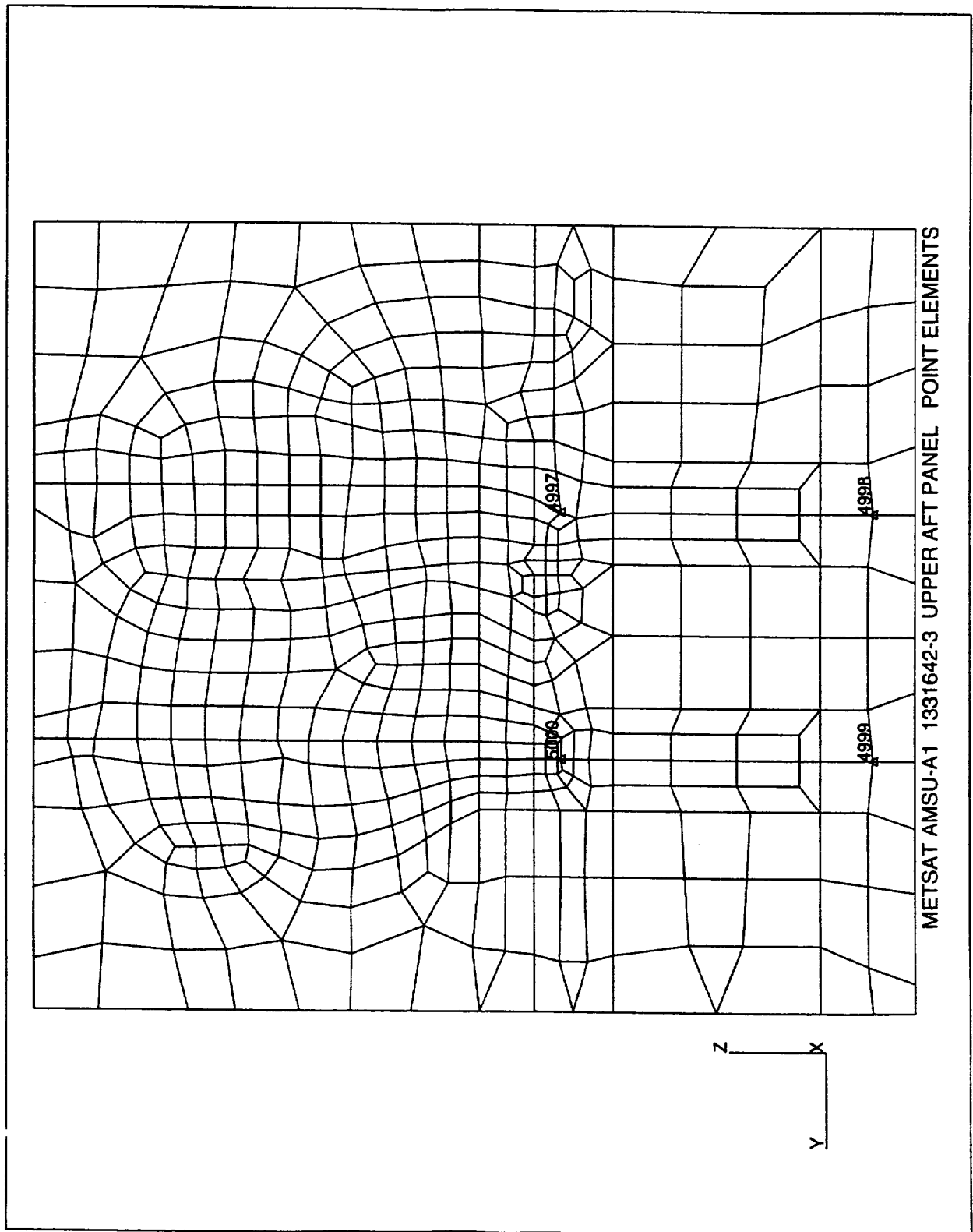

Figure A-38 METSAT AMSU-A1 1331642-3 Upper Aft Panel Point Elements

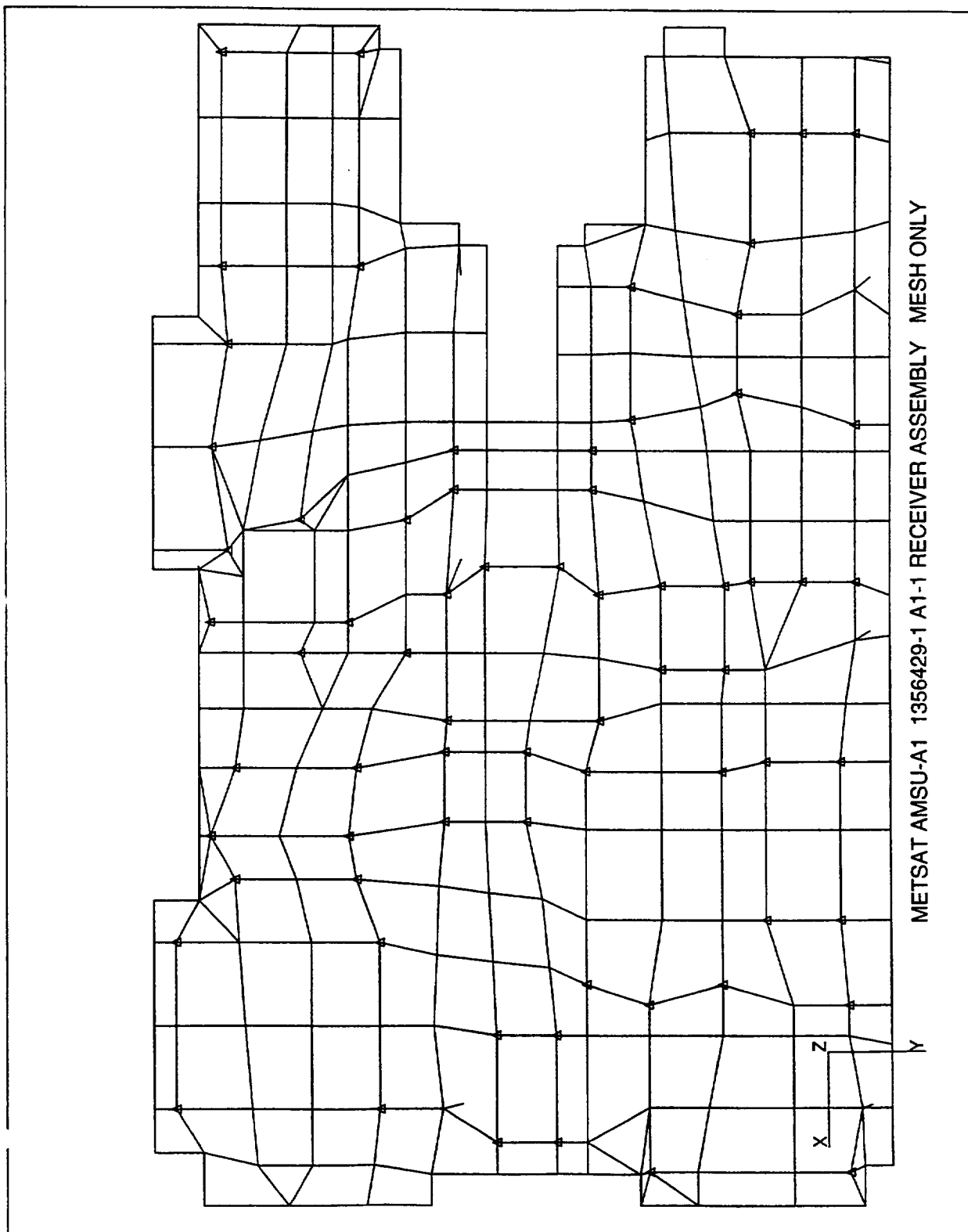

Figure A-39 METSAT AMSU-A1 1356429-1 A1-1 Receiver Assembly Mesh Only

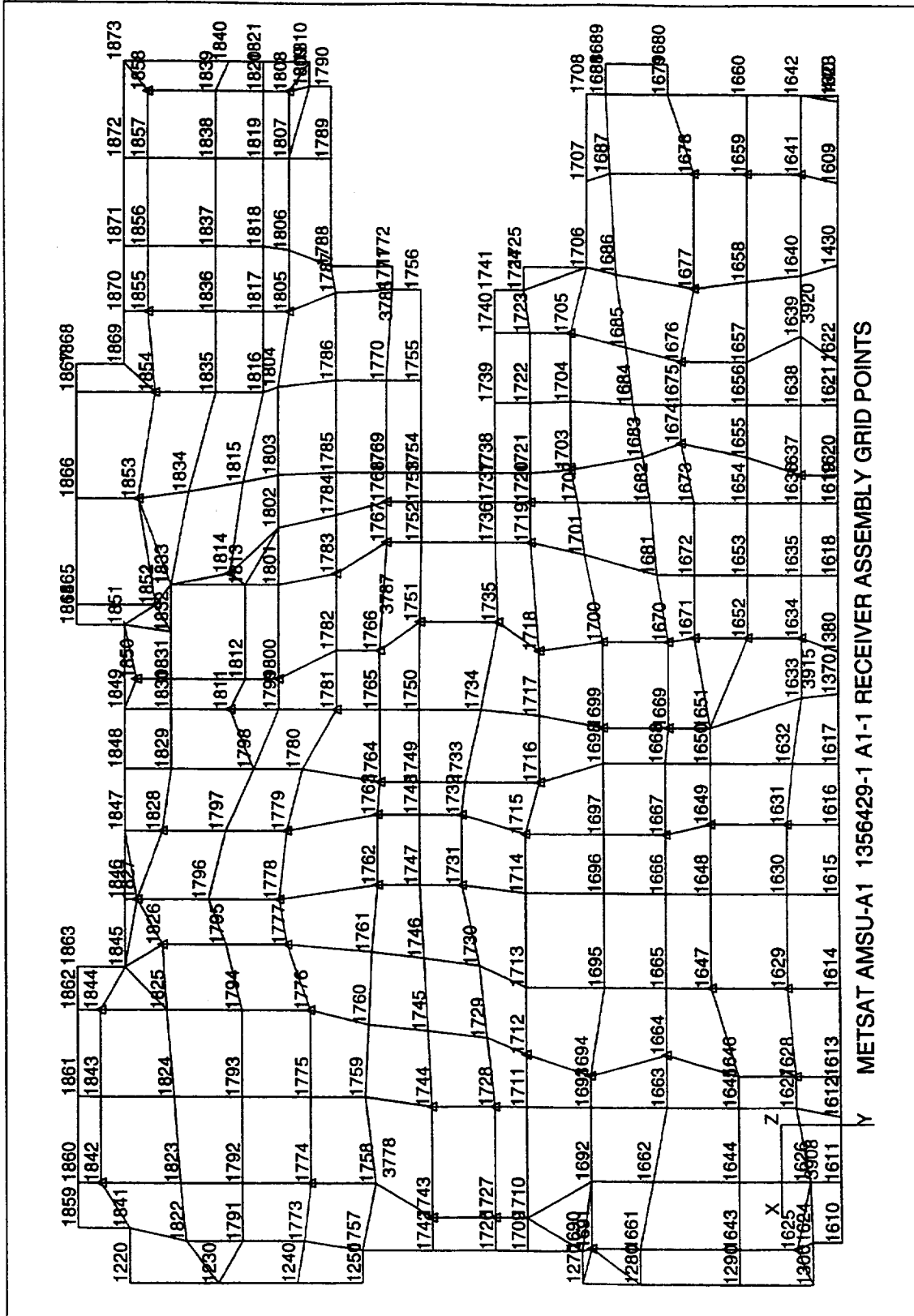

Figure A-40 METSAT AMSU-A1 1356429-1 A1-1 Receiver Assembly Grid Points

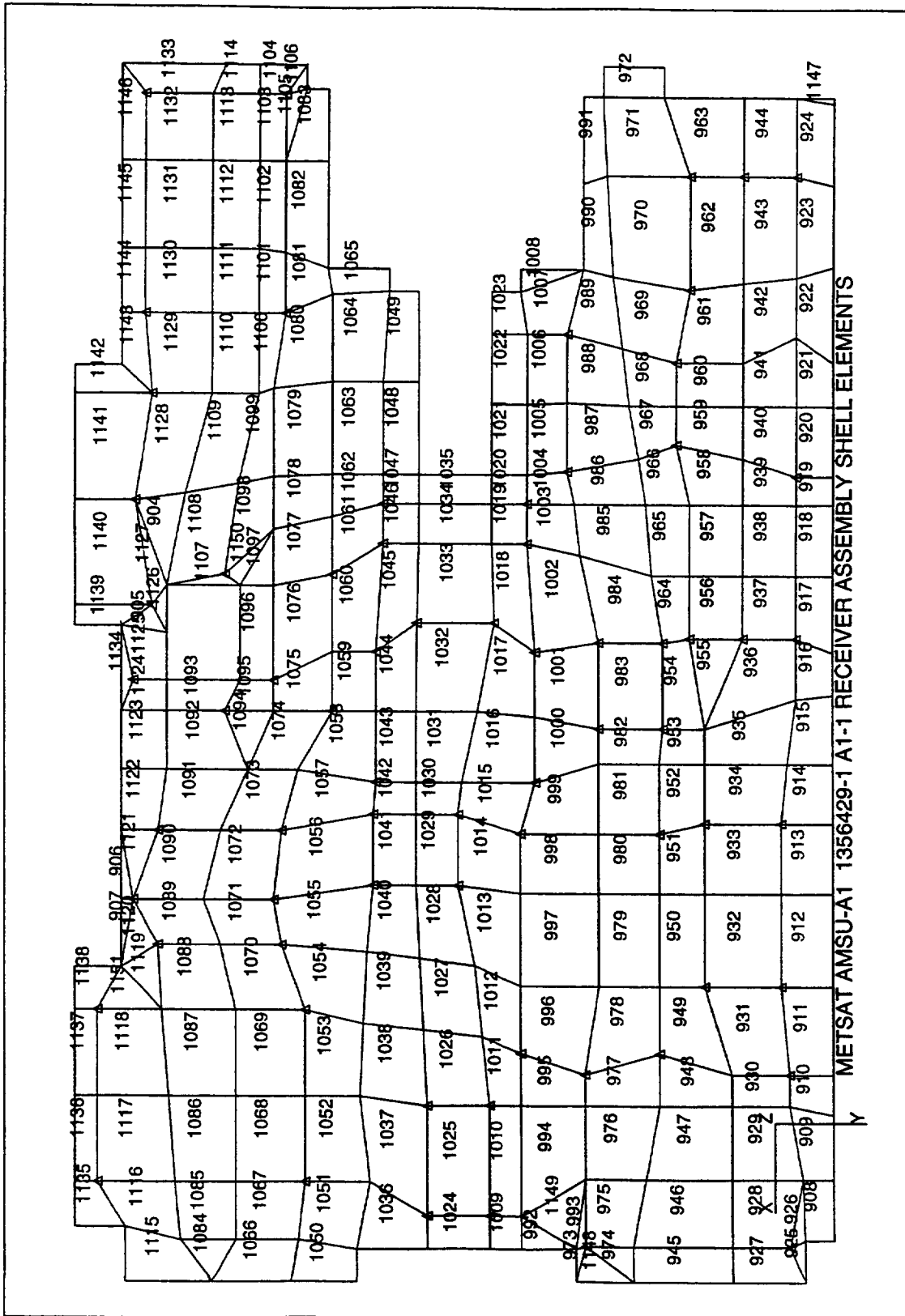

Figure A-41 METSAT AMSU-A1 1356429-1 A1-1 Receiver Assembly Shell Elements

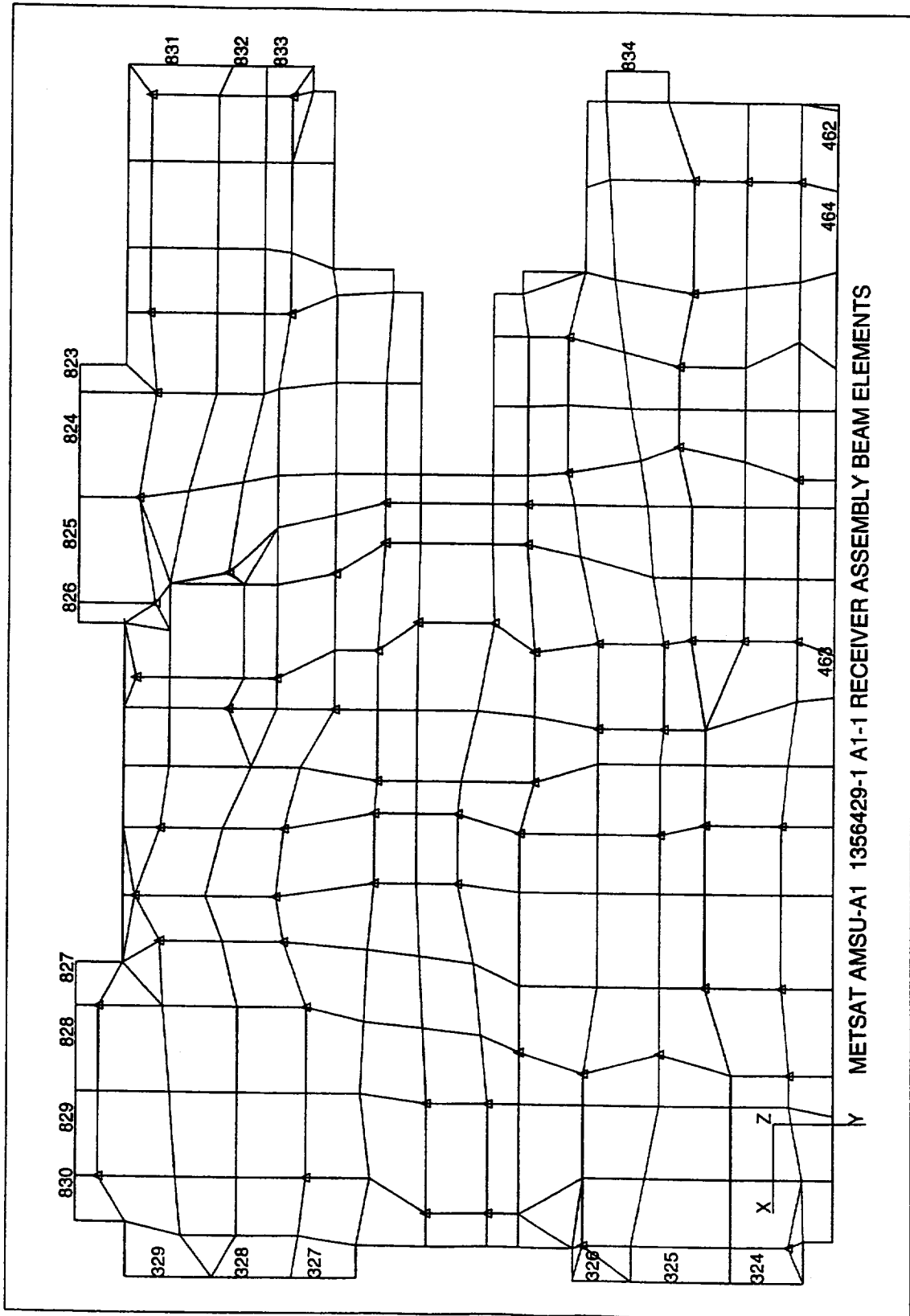

Figure A-42 METSAT AMSU-A1 1356429-1 A1-1 Receiver Assembly Beam Elements

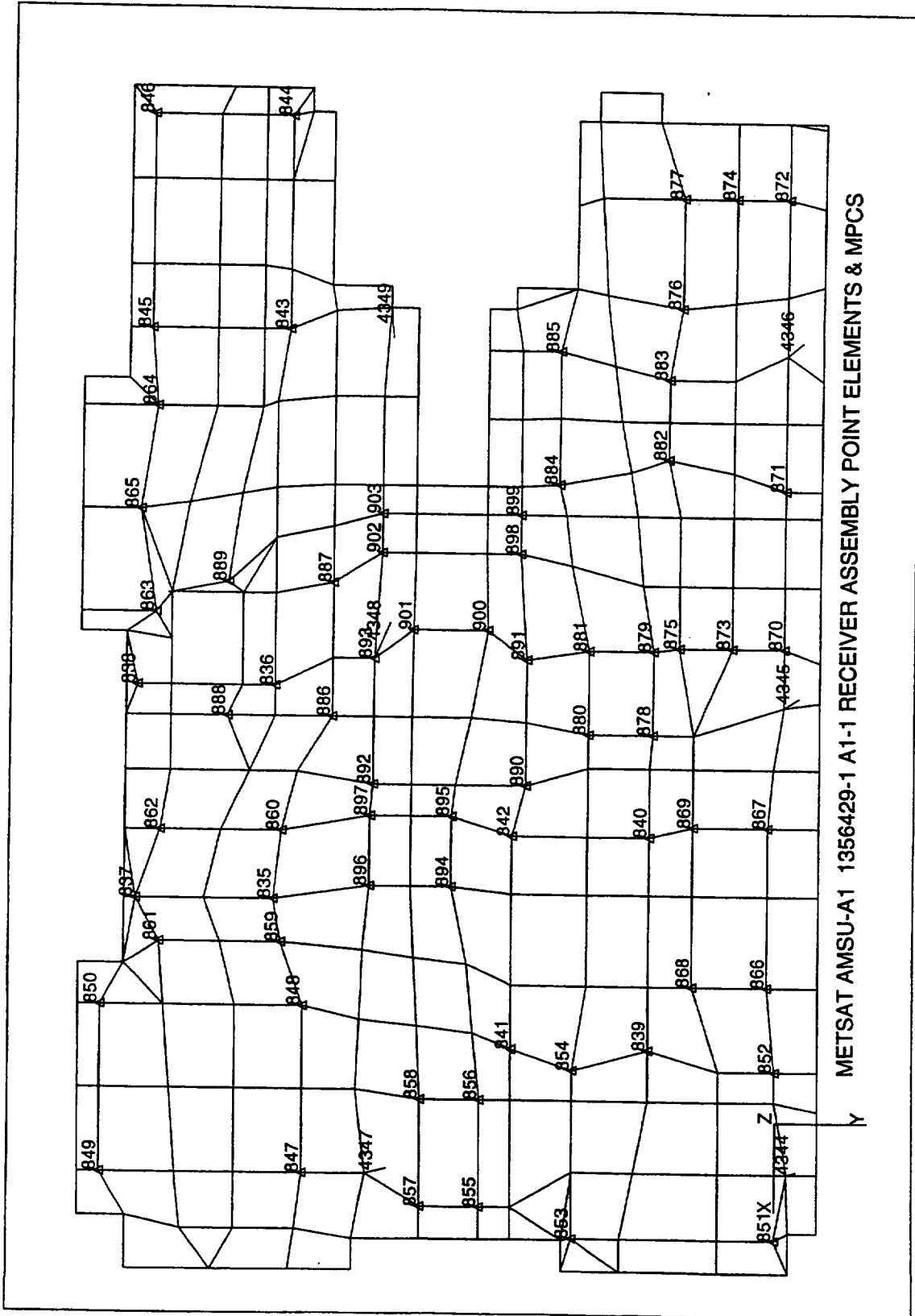

Figure A-43 METSAT AMSU-A1 1356429-1 A1-1 Receiver Assembly Point Elements & MPCs

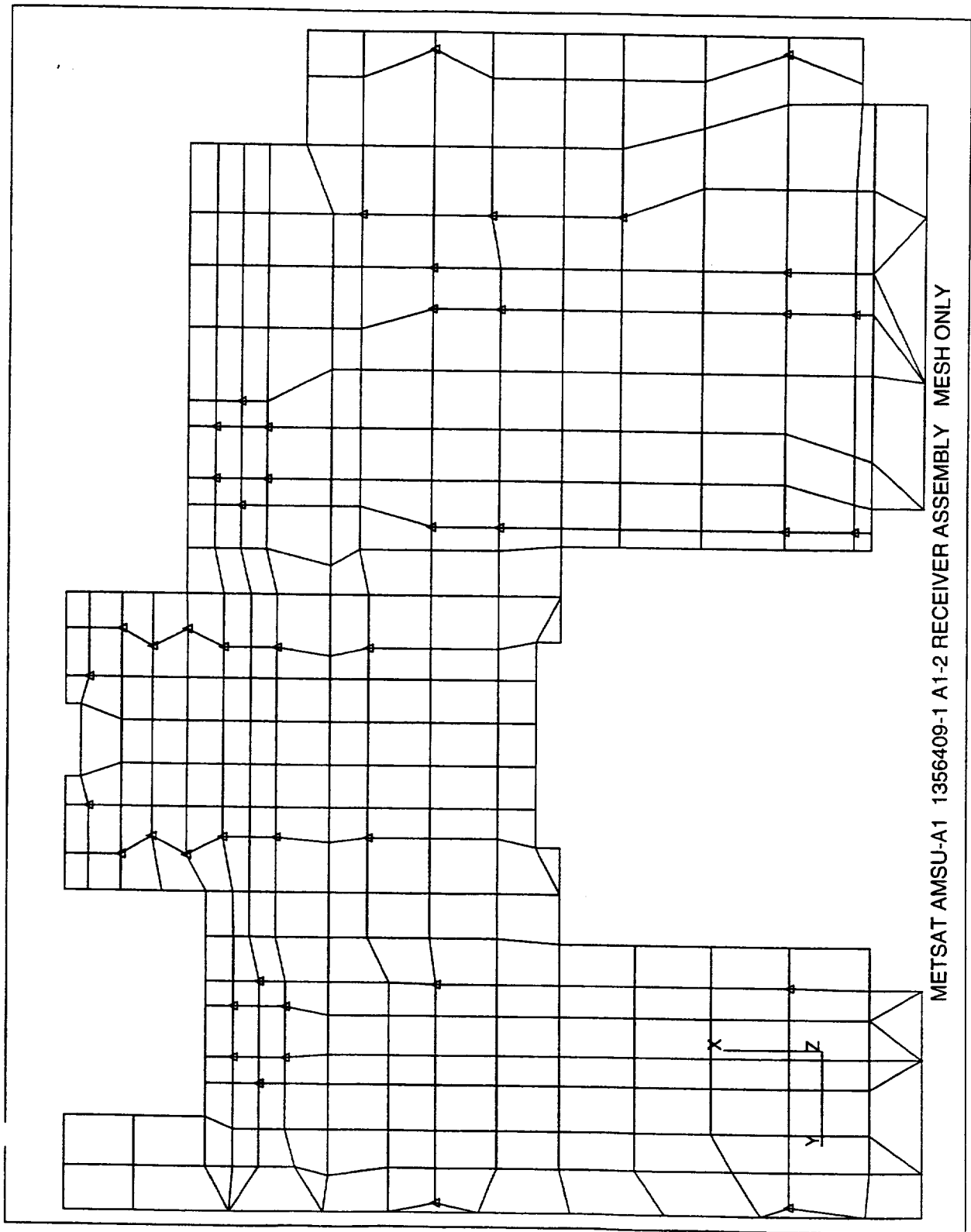

Figure A-44 METSAT AMSU-A1 1356409-1 A1-2 Receiver Assembly Mesh Only

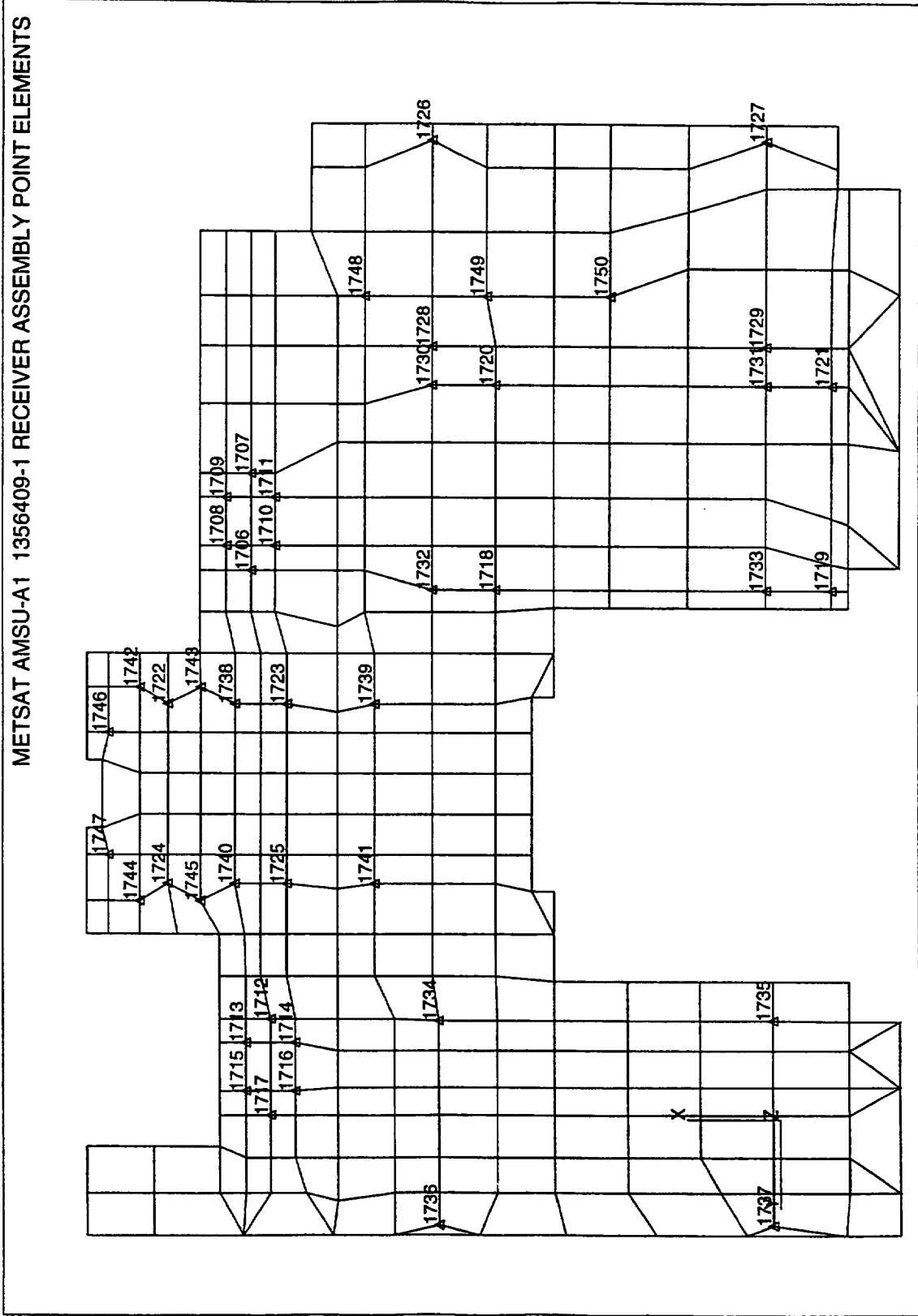
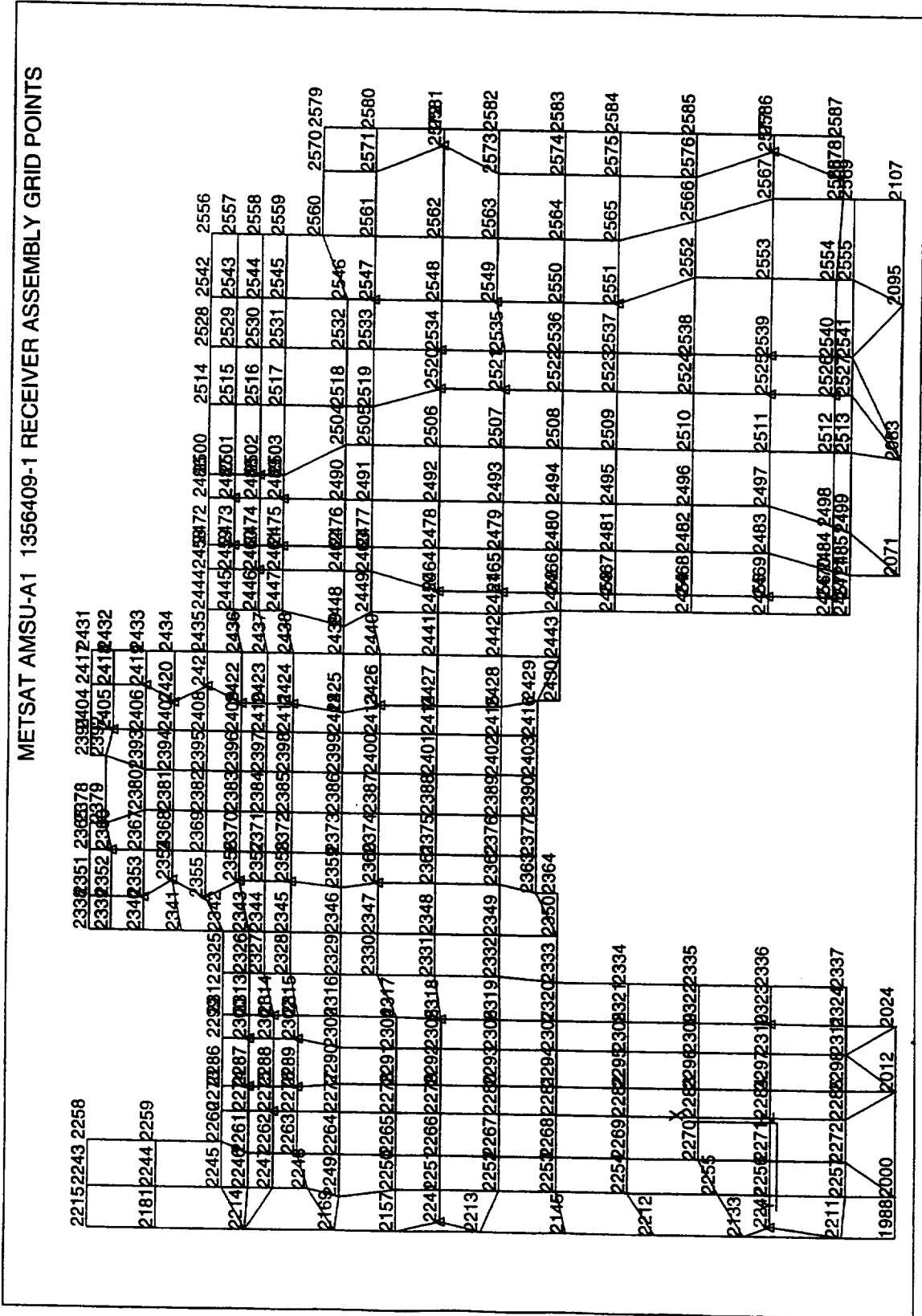

Figure A-45 METSAT AMSU-A1 1356409-1 Receiver Assembly Point Elements



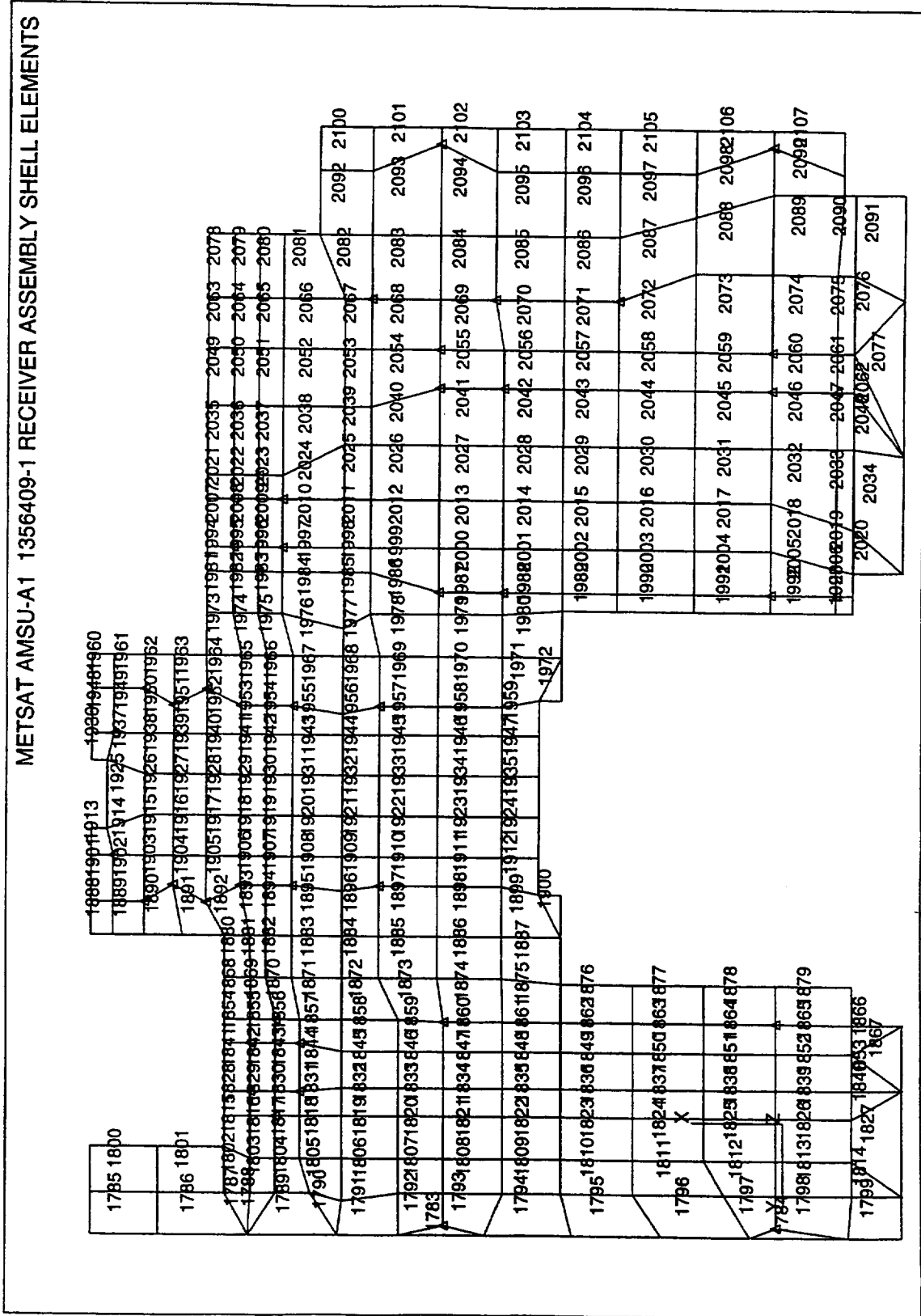

Figure A-47 METSAT AMSU-A1 1356409-1 Receiver Assembly Shell Elements

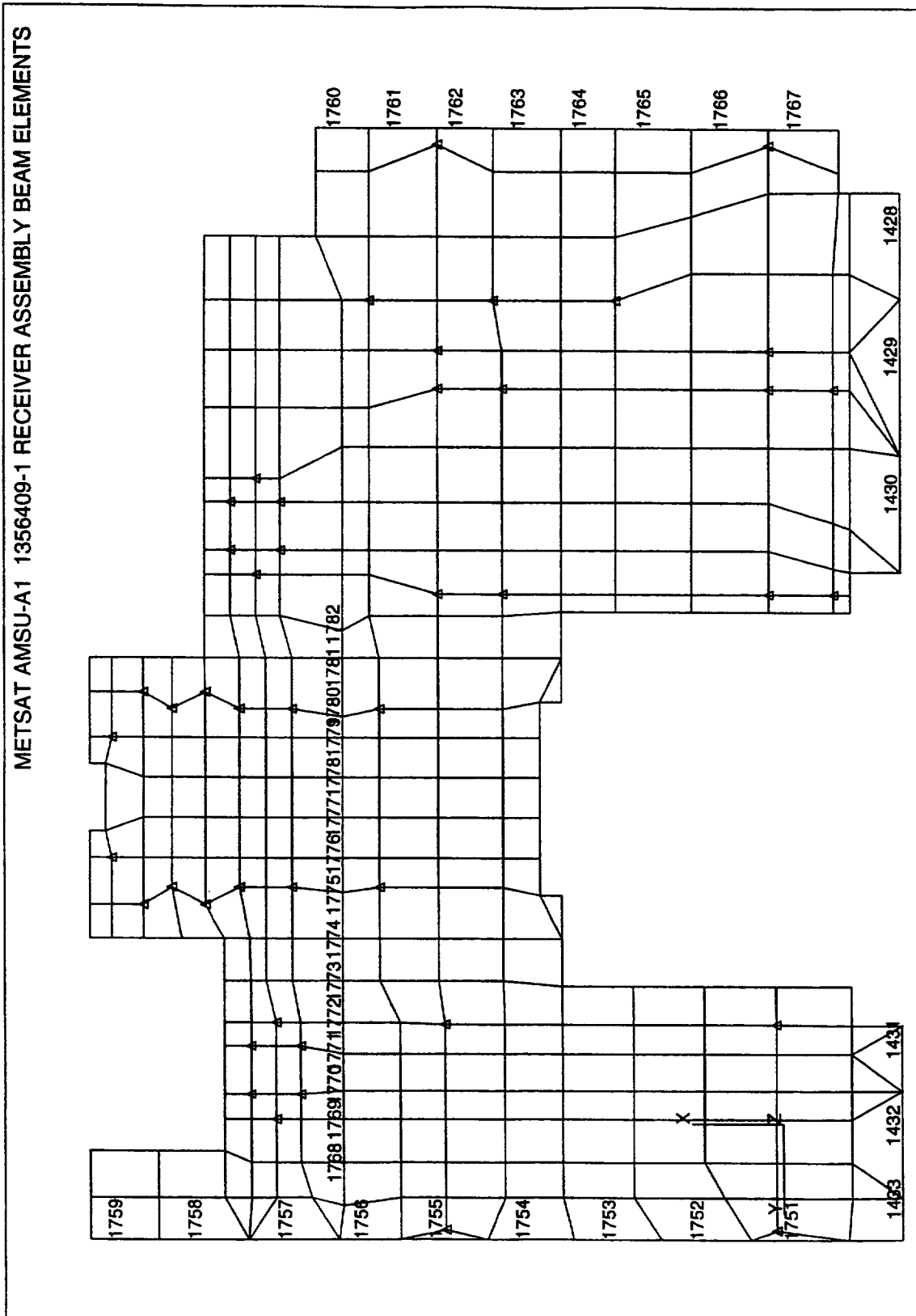

Figure A-48 METSAT AMSU-A1 1356409-1 Receiver Assembly Beam Elements

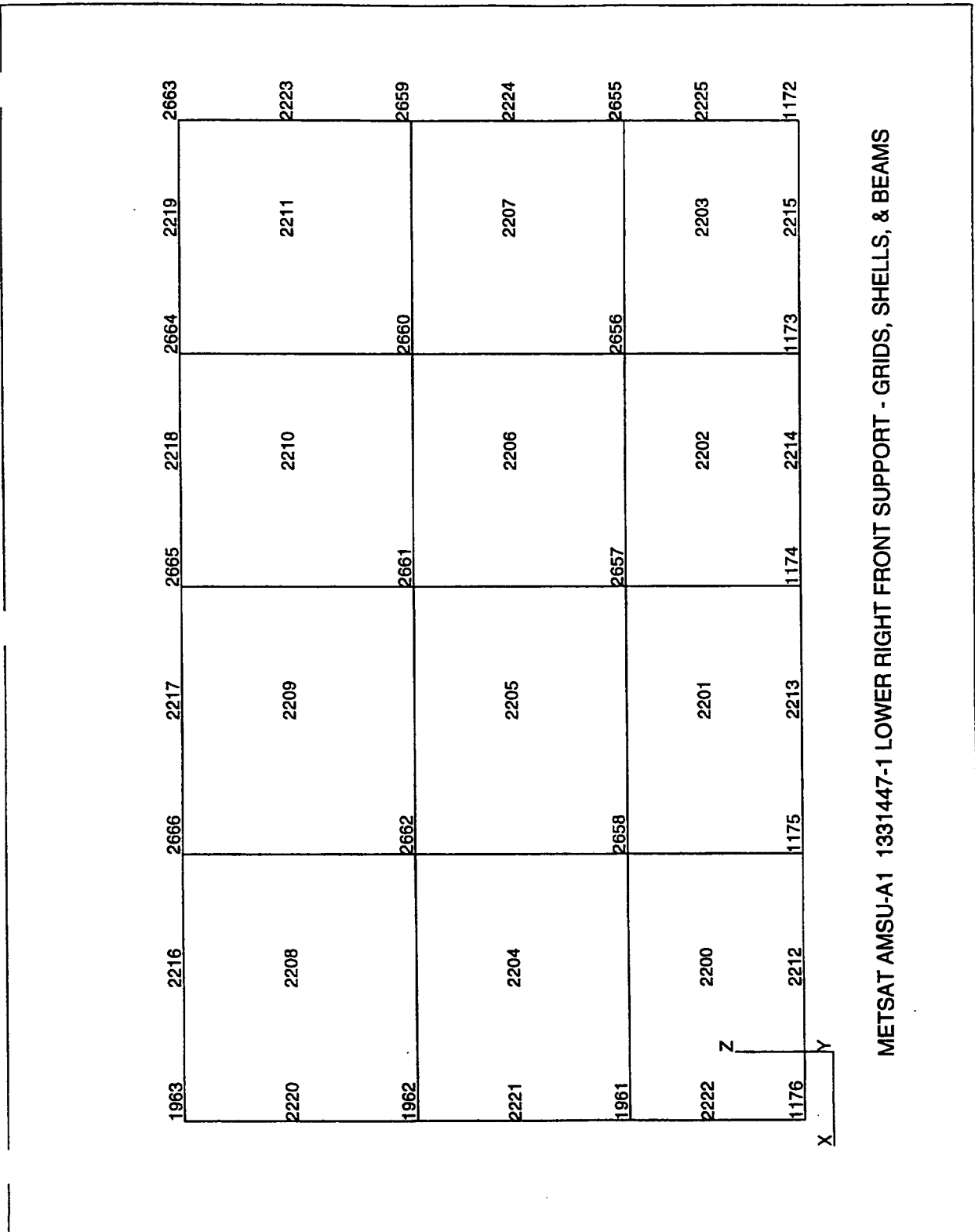

Figure A-49 METSAT AMSU-A1 1331447-1 Lower Right Front Support - Grids, Shells, & Beams

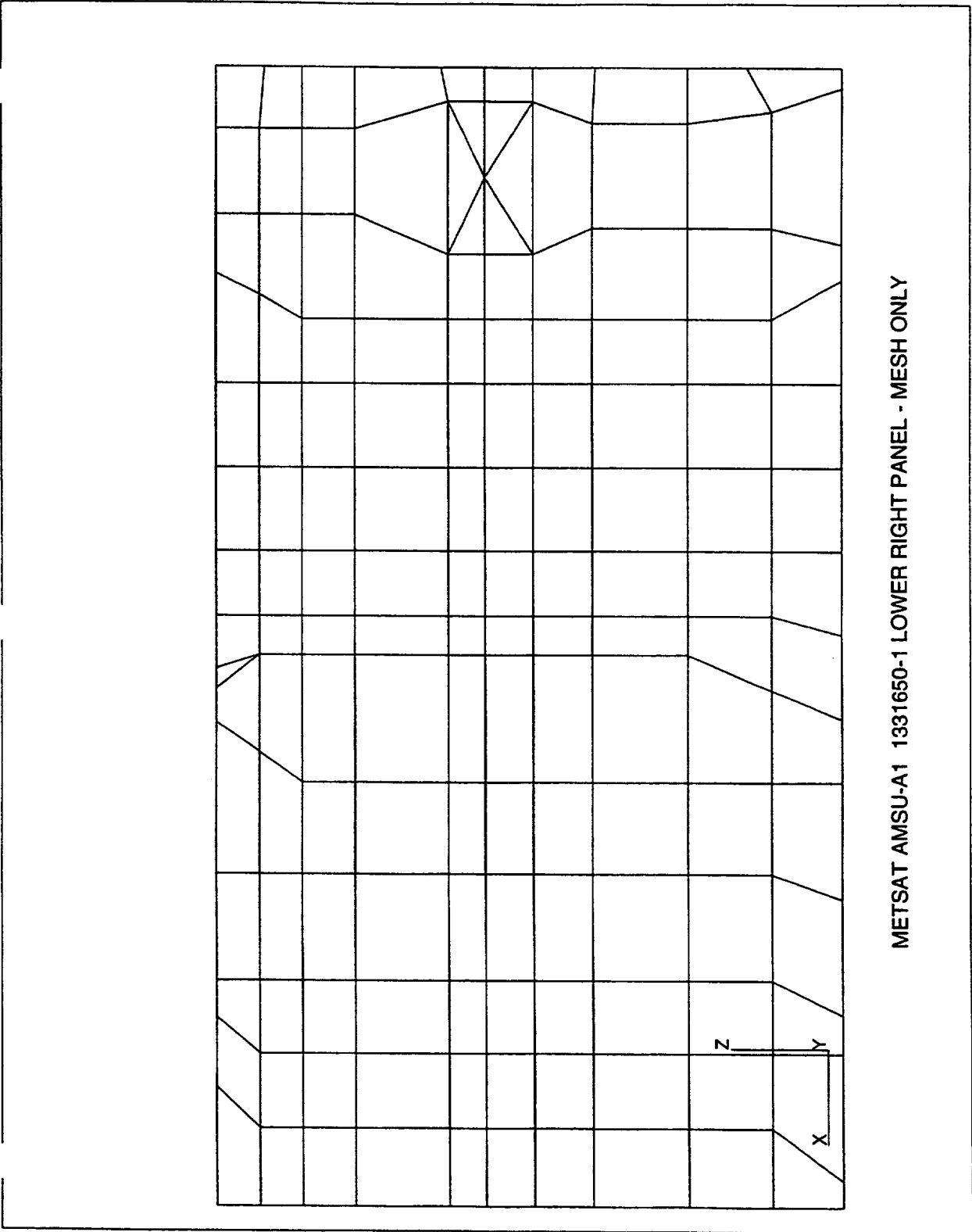

Figure A-50 METSAT AMSU-A1 1331650-1 Lower Right Panel Mesh only

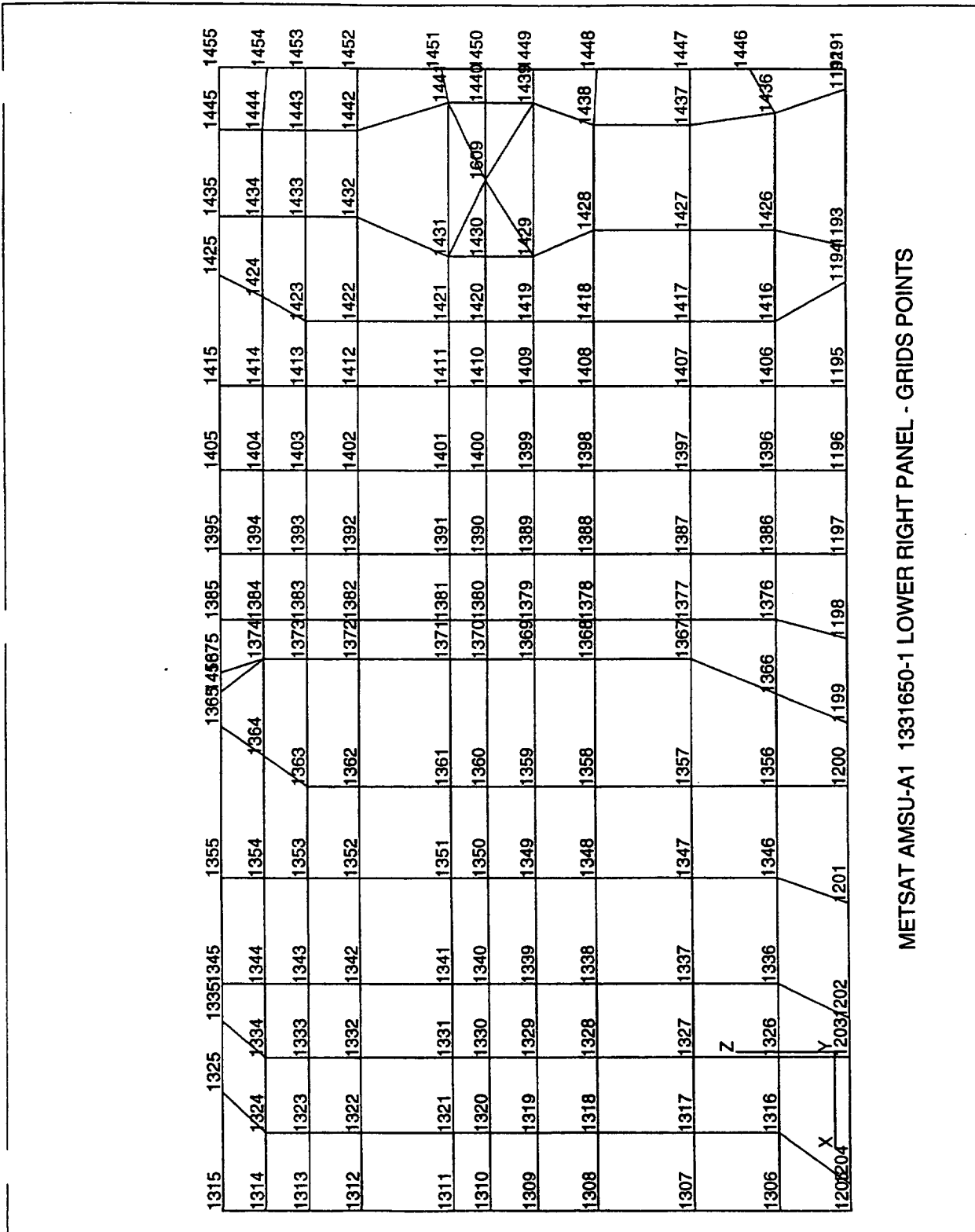

Figure A-51 METSAT AMSU-A1 1331650-1 Lower Right Panel - Grid Points

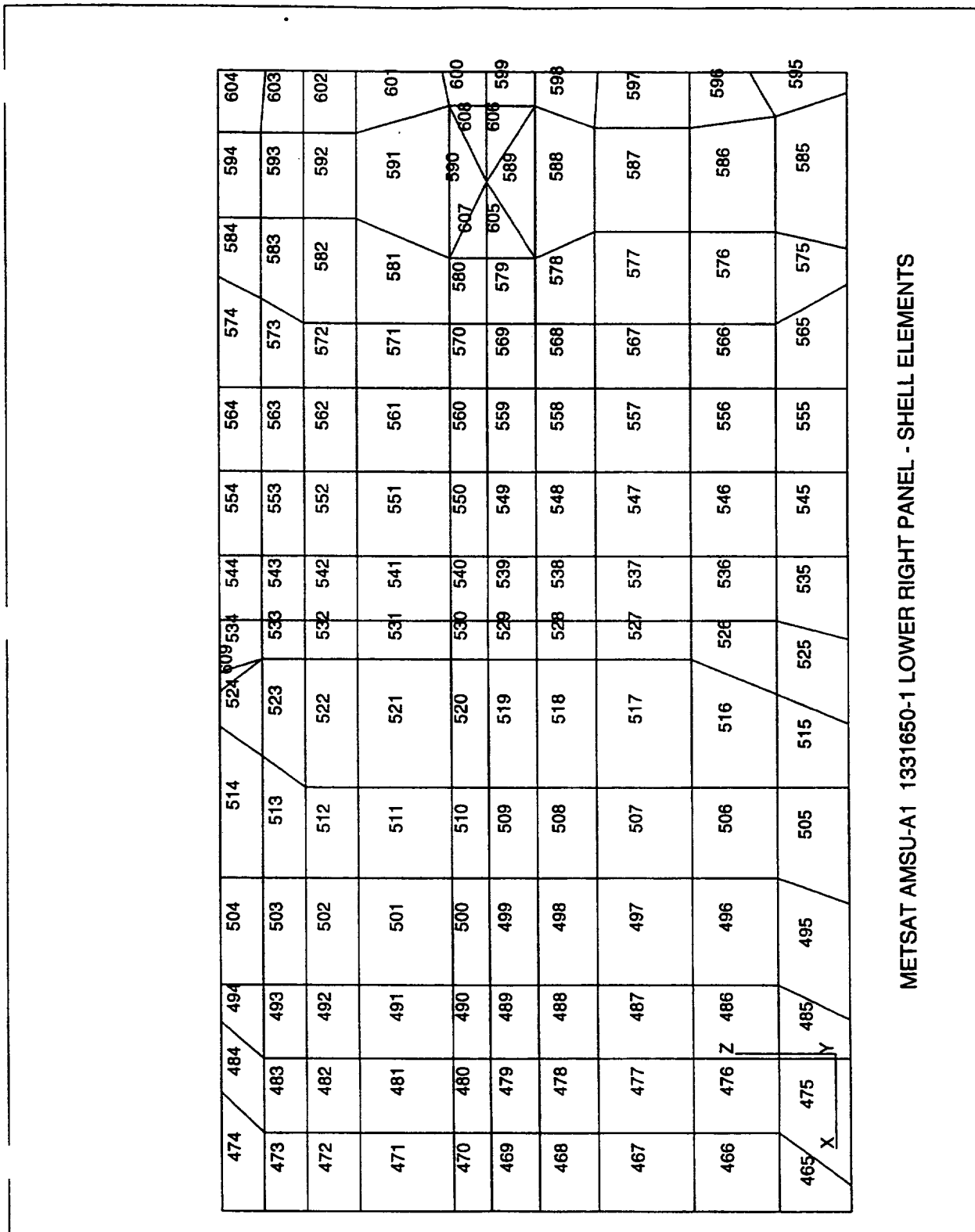

Figure A-52 METSAT AMSU-A1 1331650-1 Lower Right Panel - Shell Elements

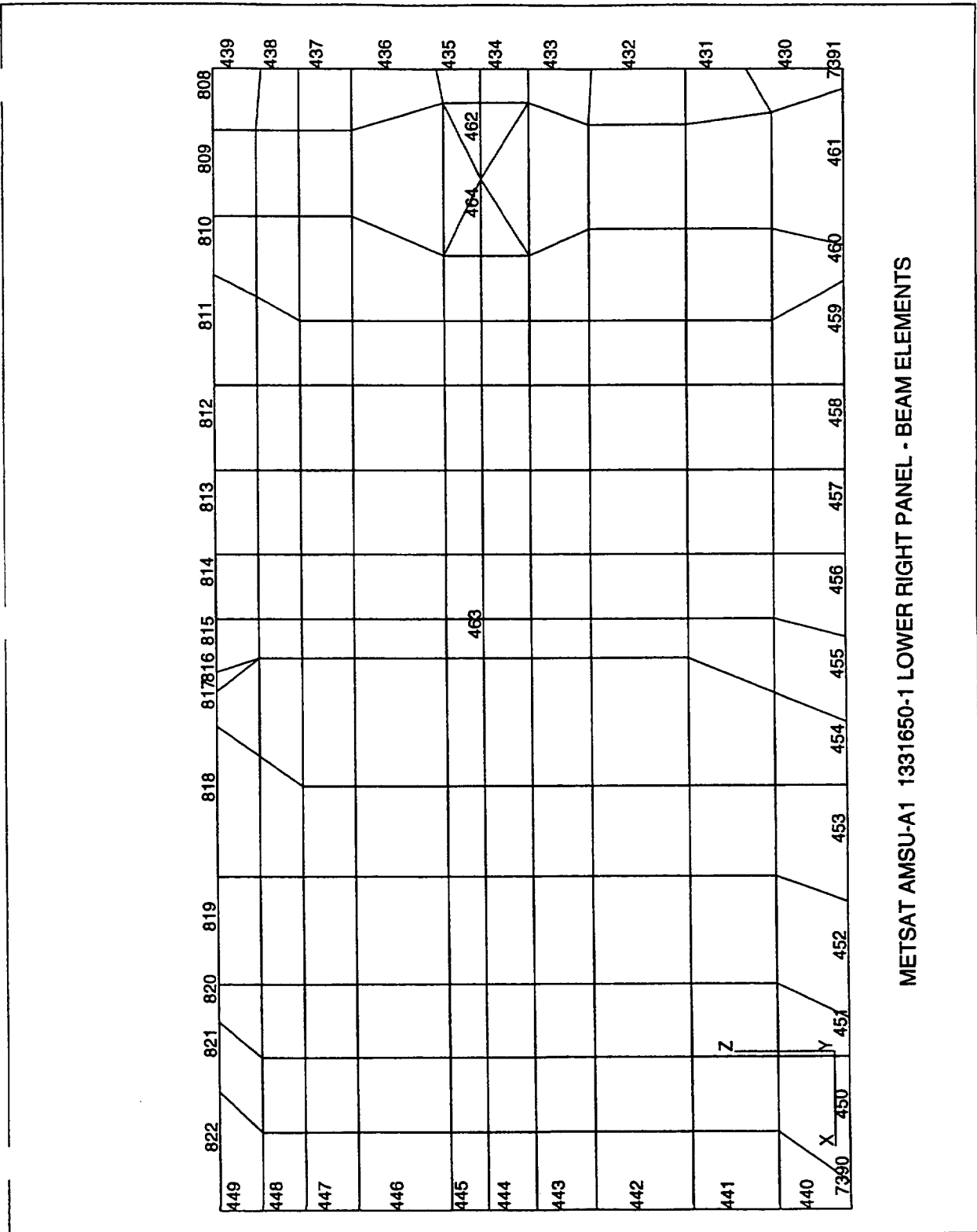

Figure A-53 METSAT AMSU-A1 133650-1 Lower Right Panel - Beam Elements

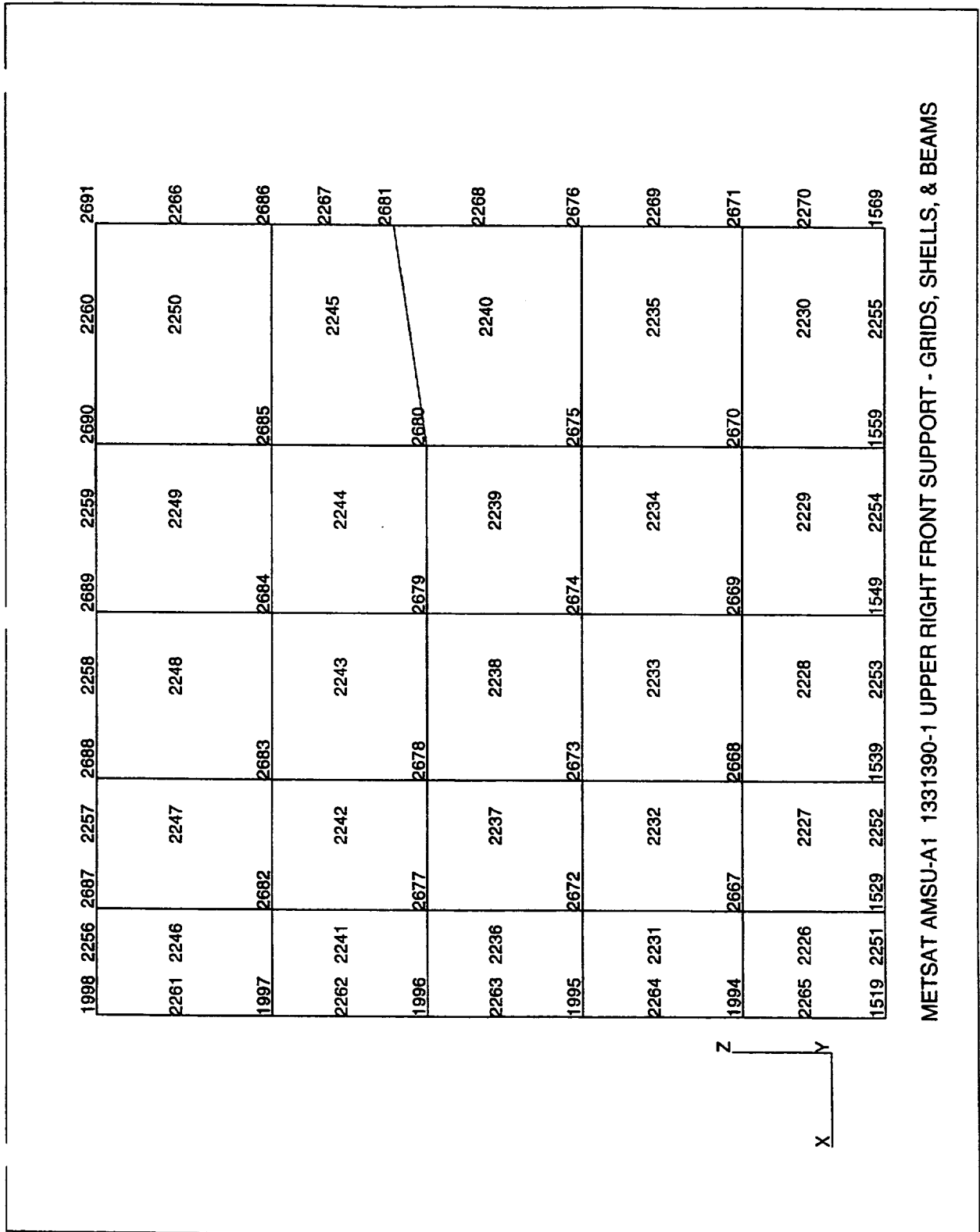

Figure A-54 METSAT AMSU-A1 1331390-1 Upper Right Front Support - Grids, Shells, & Beams

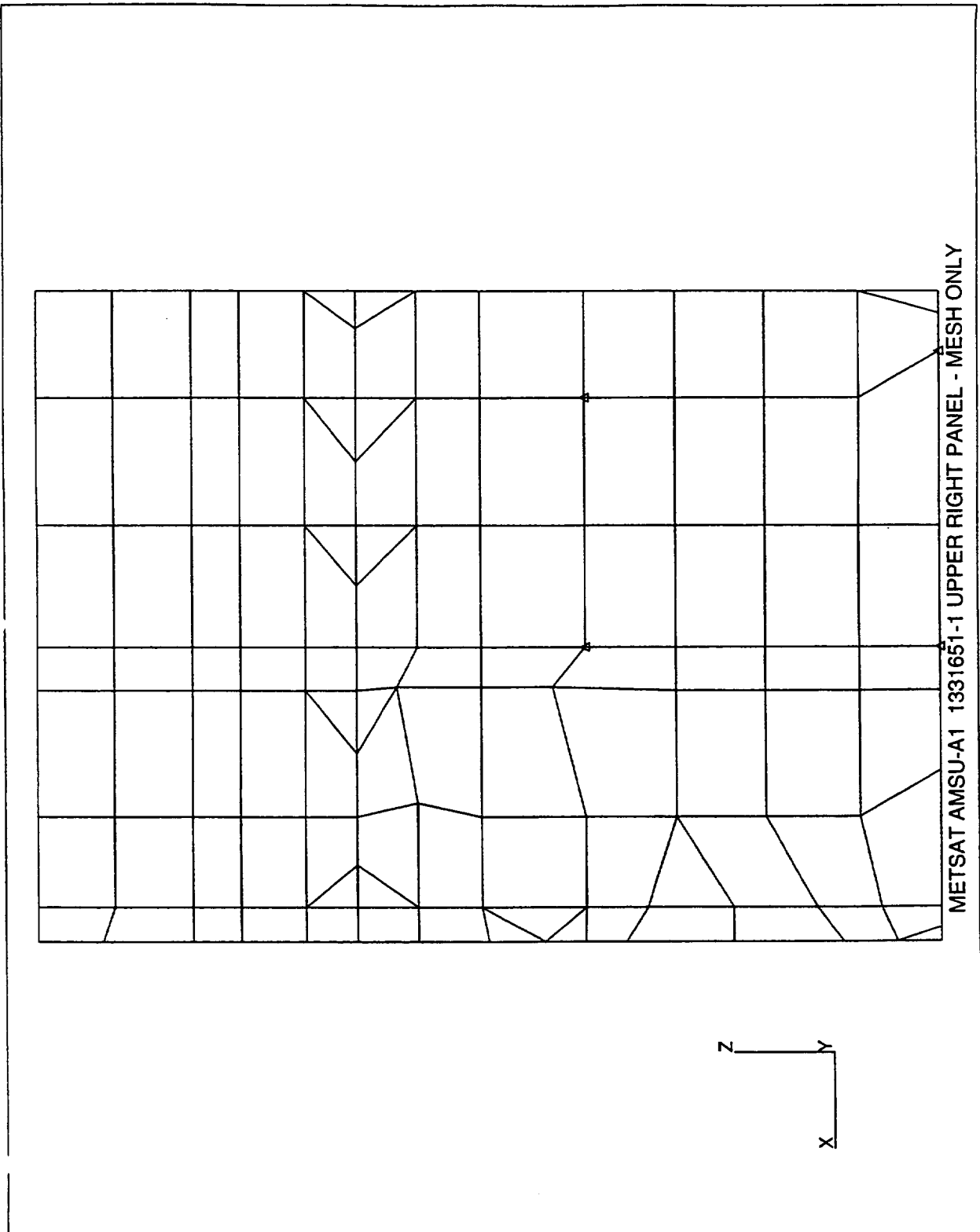

Figure A-55 METSAT AMSU-A1 1331651-1 Upper Right Panel Mesh Only

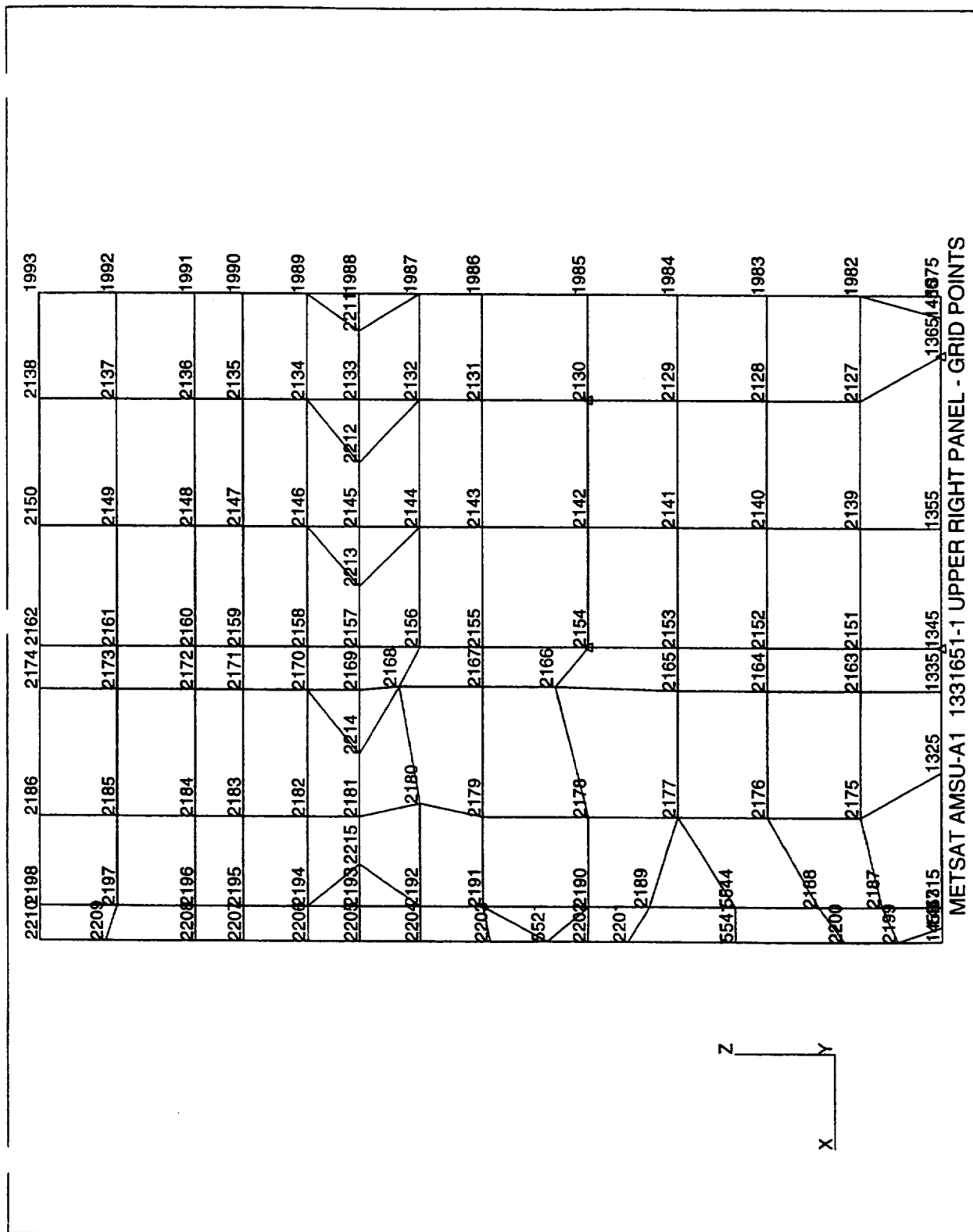

Figure A-56 METSAT AMSU-A1 1331651-1 Upper Right Panel Grid Points

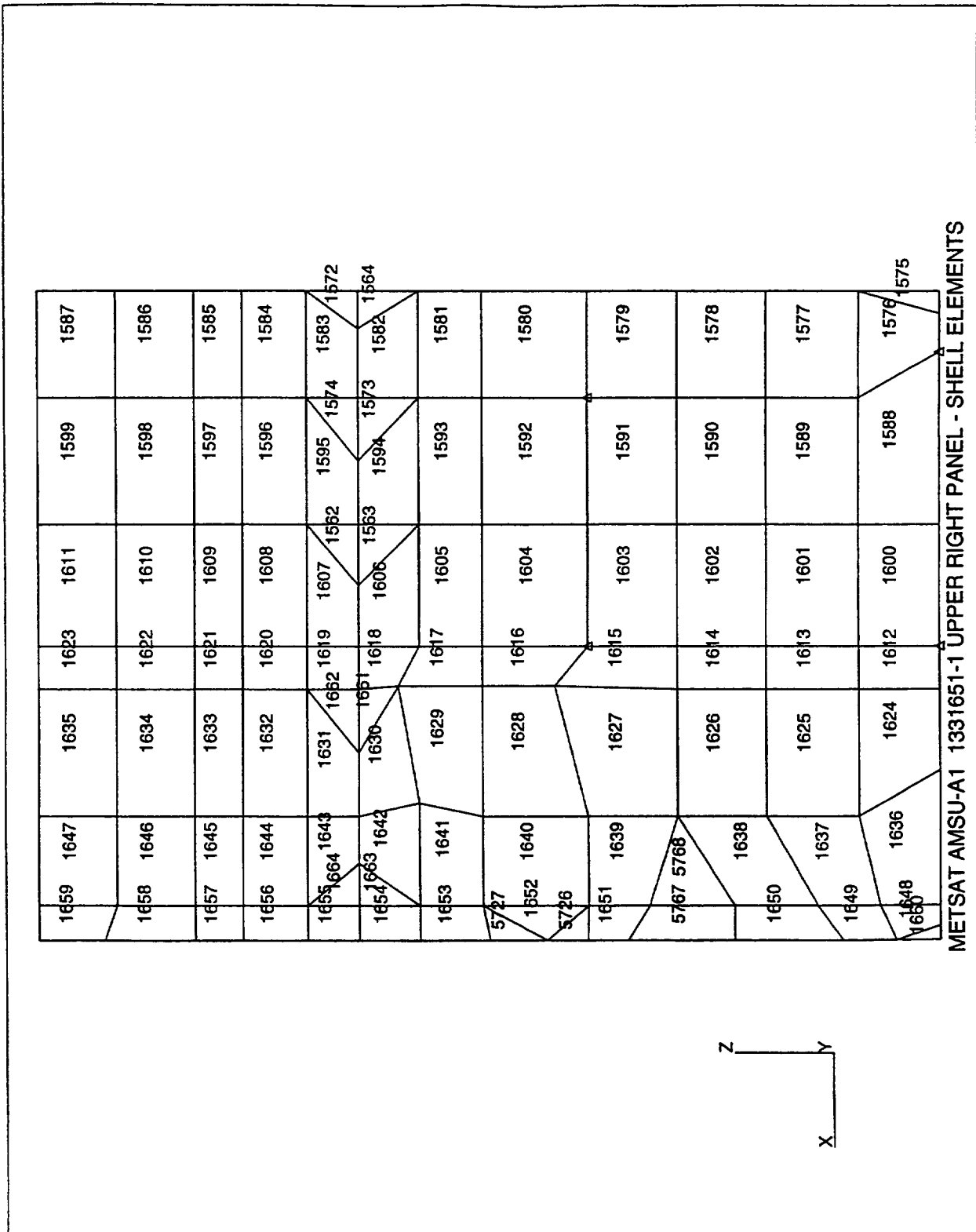

Figure A-57 METSAT AMSU-A1 1331651-1 Upper Right Panel Shell Elements

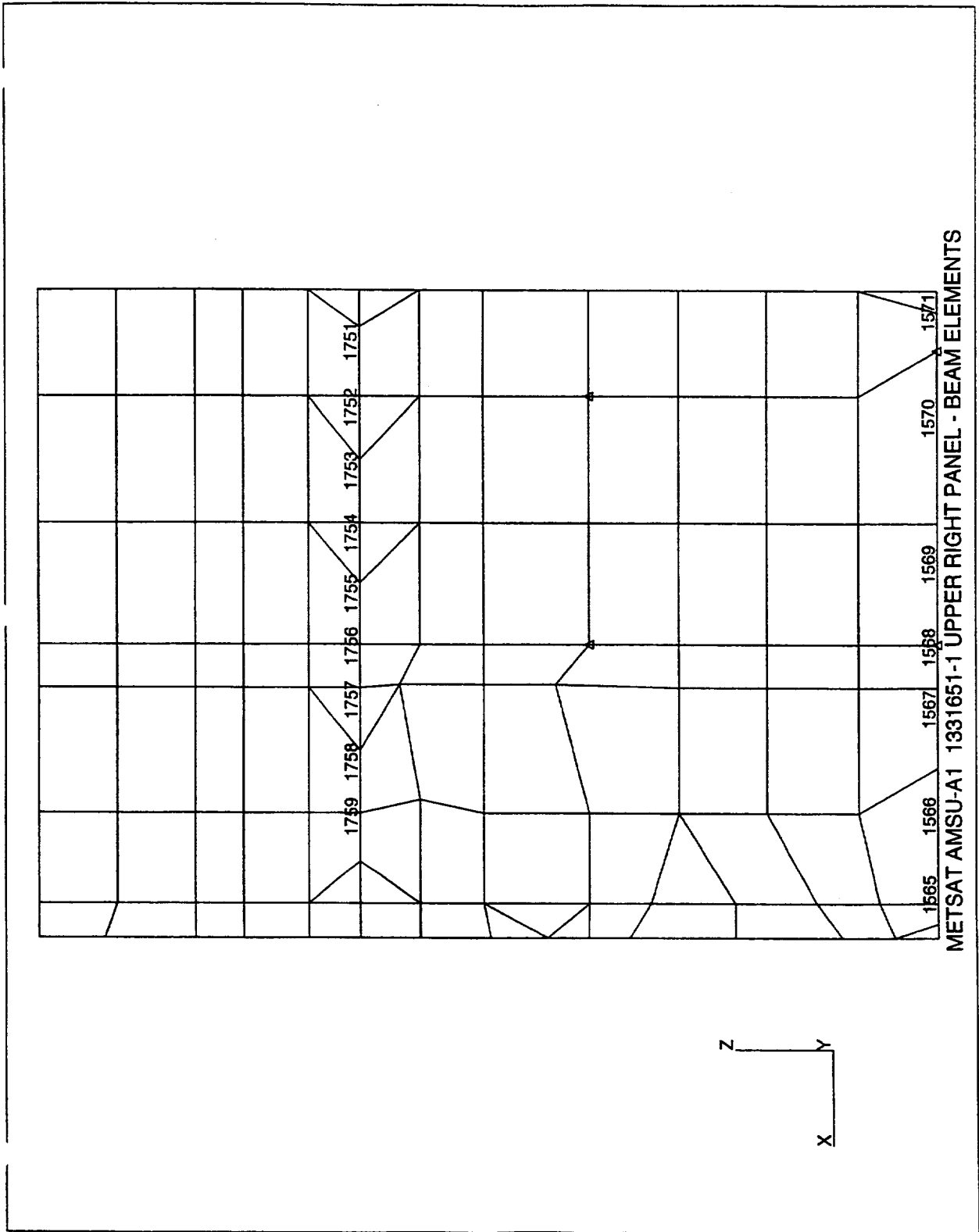

Figure A-58 METSAT AMSU-A1 1331651-1 Upper Right Panel Beam Elements

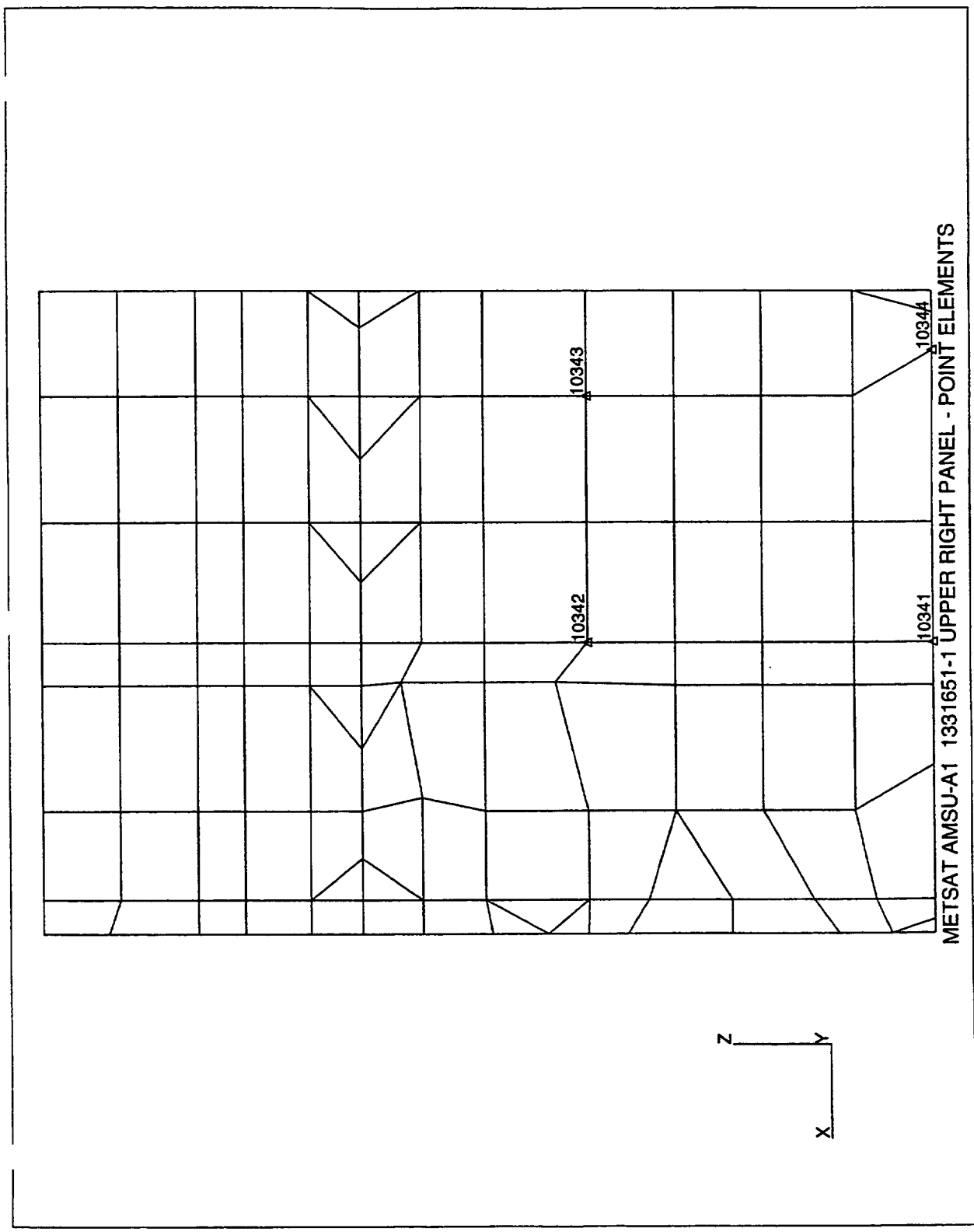

Figure A-59 METSAT AMSU-A1 1331651-1 Upper Right Panel Point Elements

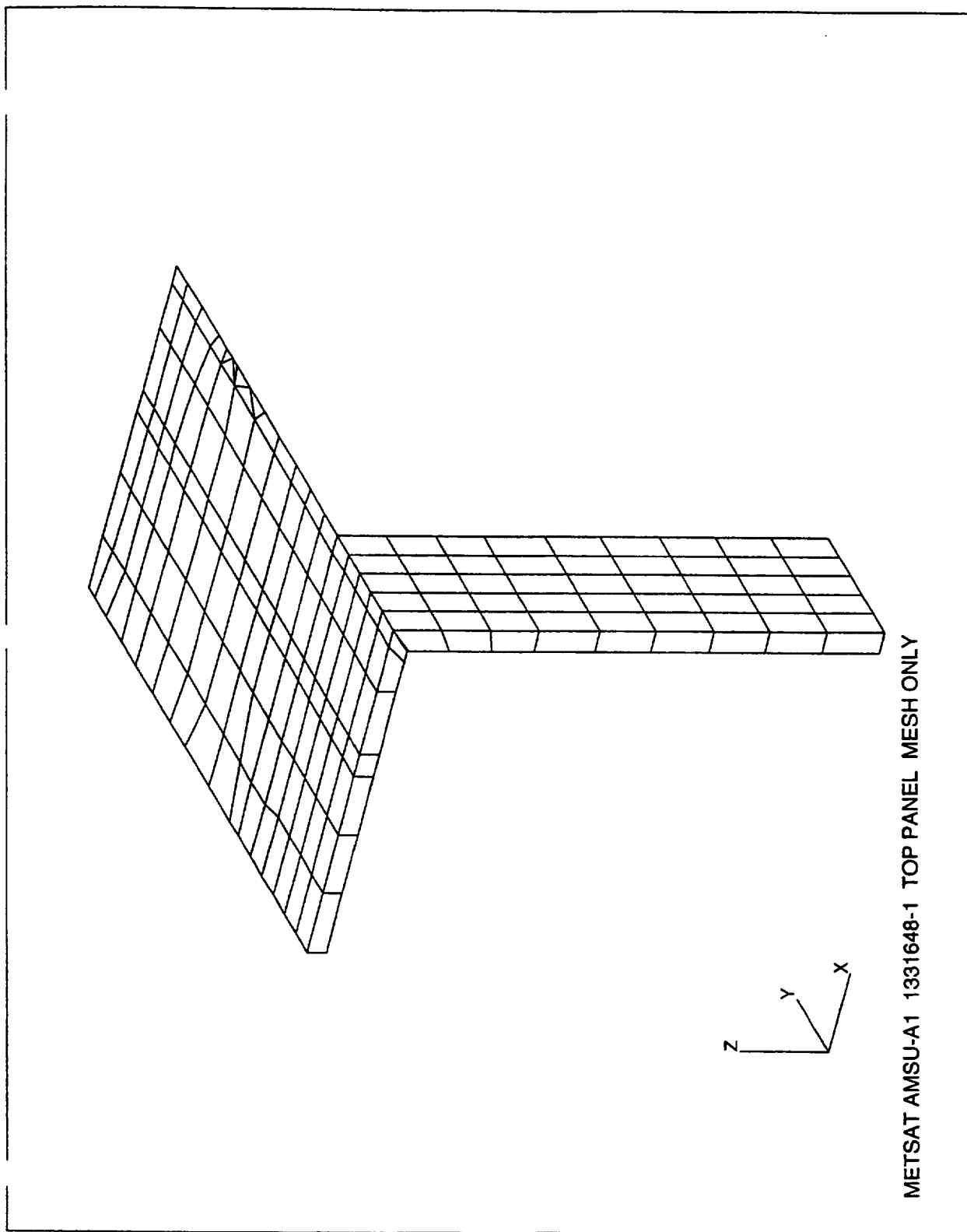

Figure A-60 METSAT AMSU-A1 1331648-1 Top Panel Mesh Only

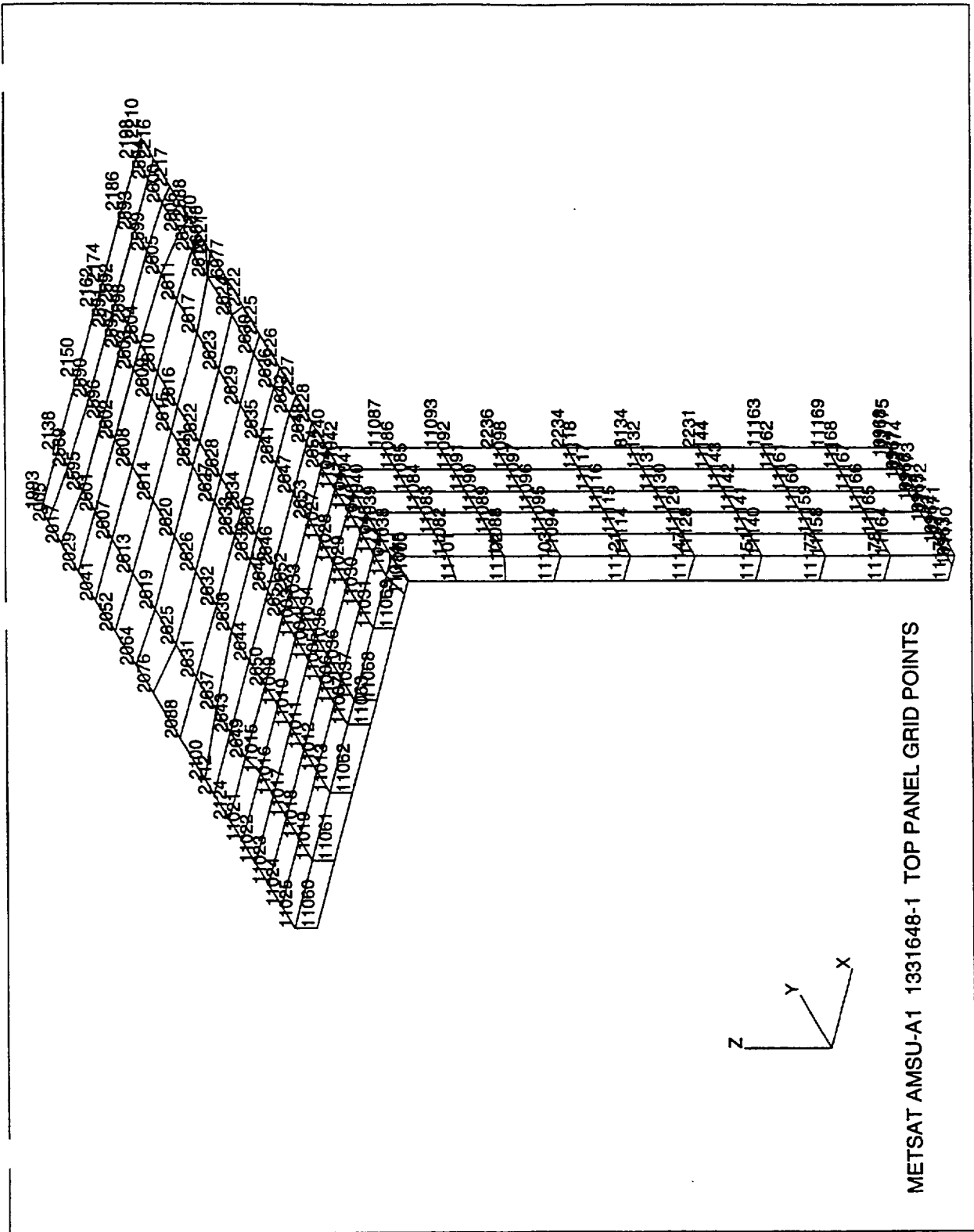

Figure A-61 METSAT AMSU-A1 1331648-1 Top Panel Grid Points

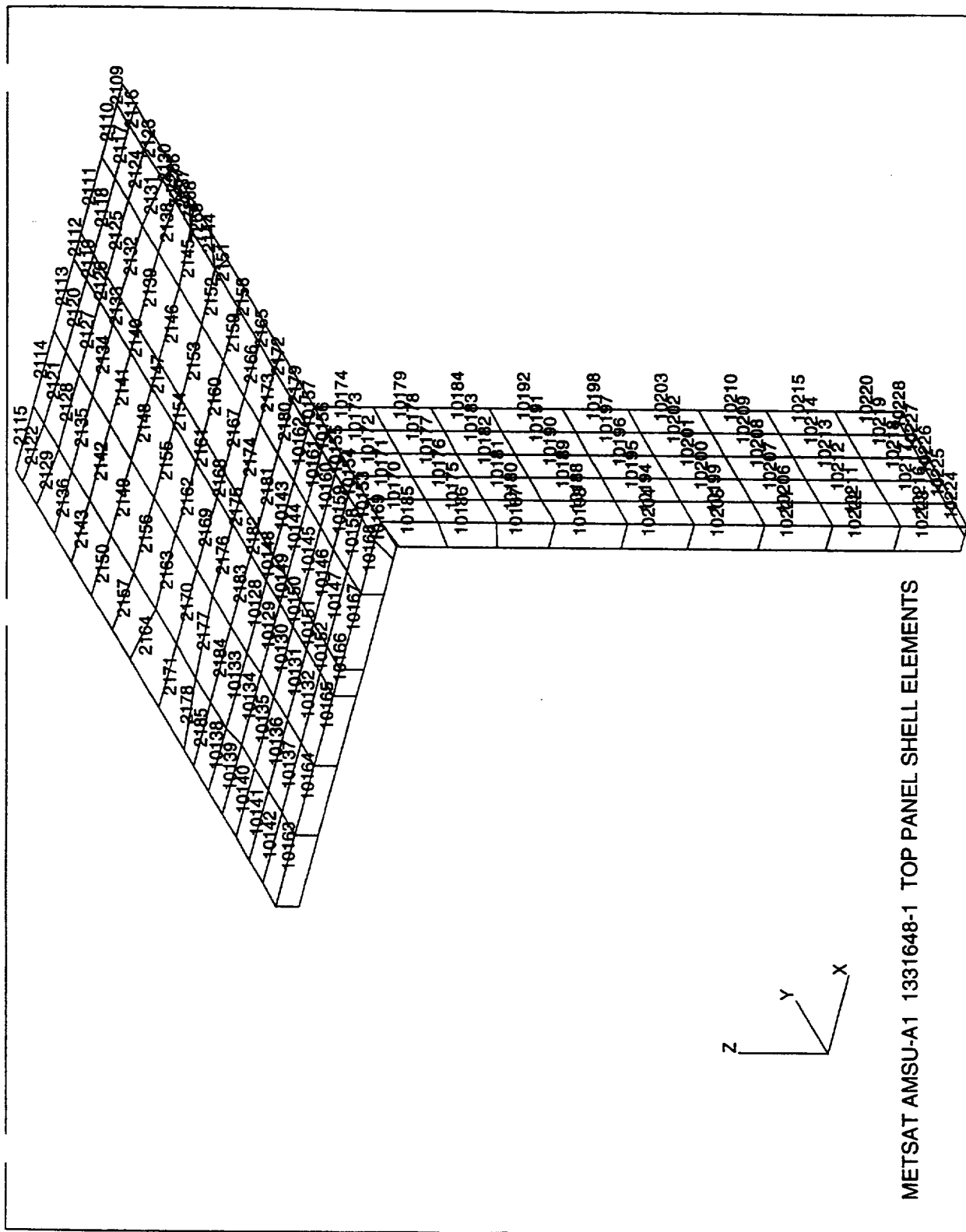

Figure A-62 METSAT AMSU-A1 1331648-1 Top Panel Shell Elements

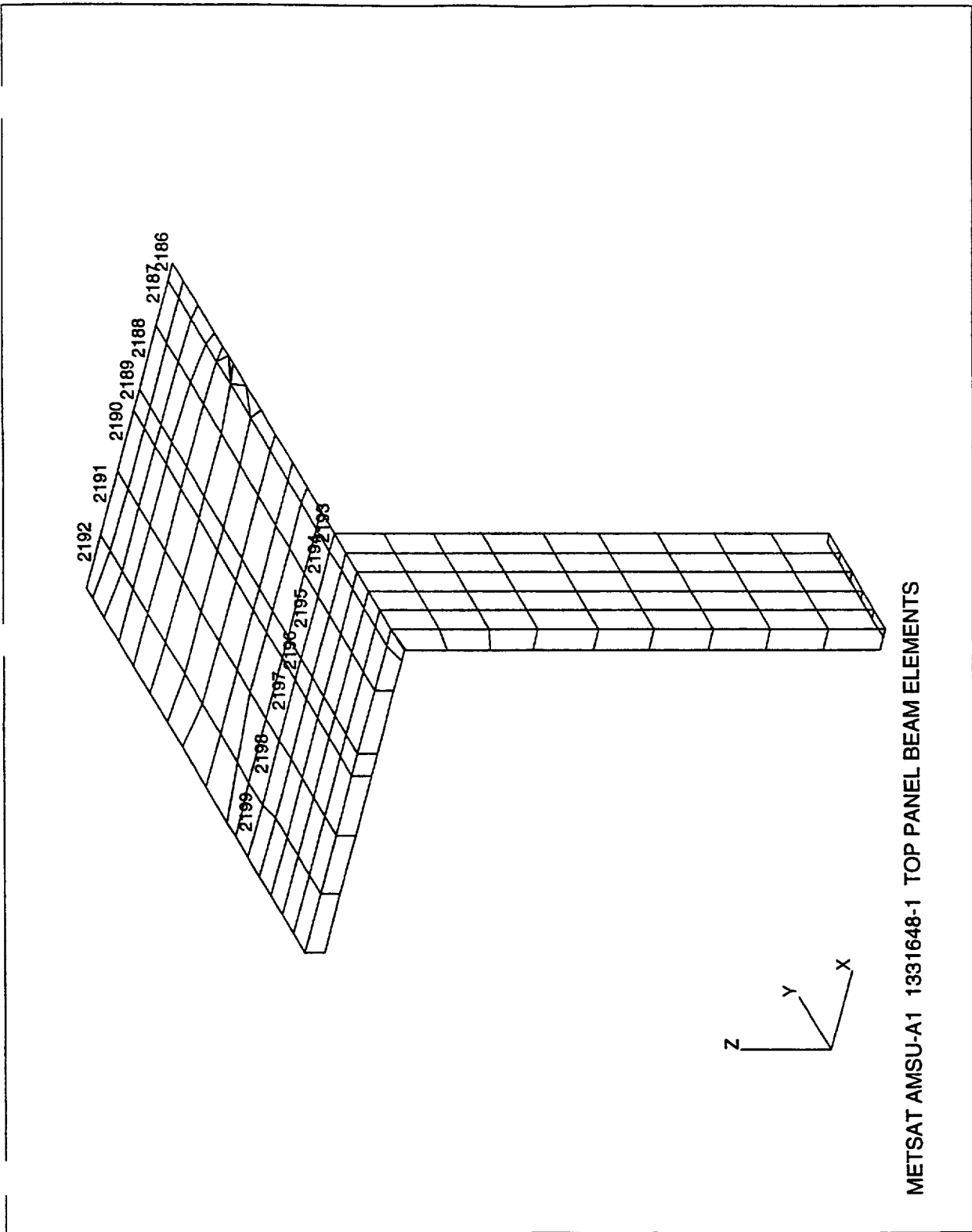

Figure A-63 METSAT AMSU-A1 1331648-1 Top Panel Beam Elements

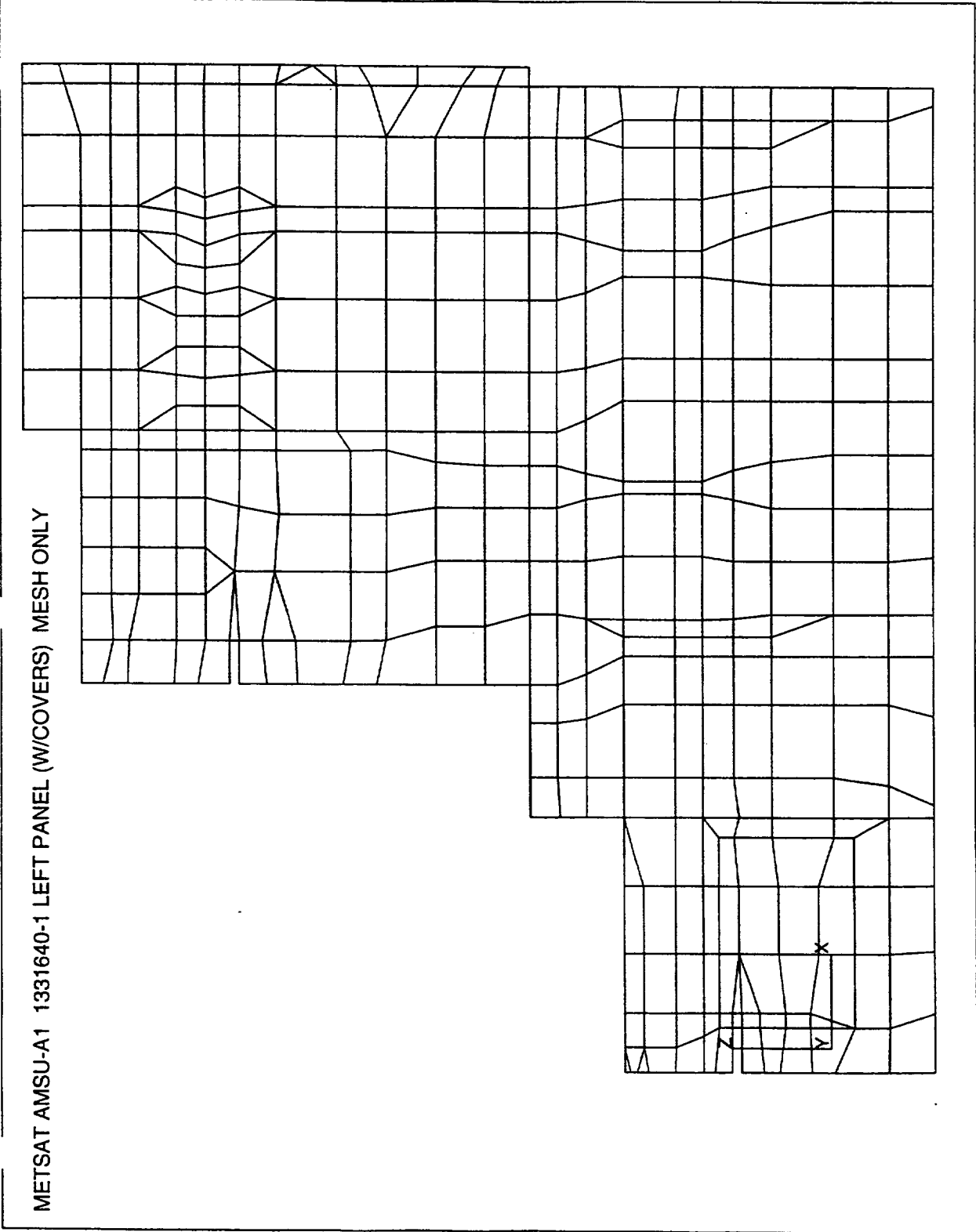

Figure A-64 METSAT AMSU-A1 1331640-1 Left Panel (W/Covers) Mesh Only

METSAT AMSU-A1 1331640-1 LEFT PANEL (W/COVERS) SHELL ELEMENTS

2920	2981	2982	2983	2984	2985	2986	2987	2988	2989	2990	2991	2992	2993	2994	2995	2996	2997	2998	2999	3000	3001	3002	3003	3004	3005	3006	3007	3008	3009	3010	3011	3012	3013	3014	3015	3016	3017	3018	3019	3020	3021	3022	3023	3024	3025	3026	3027	3028	3029	3030	3031	3032	3033	3034	3035	3036	3037	3038	3039	3040	3041	3042	3043	3044	3045	3046	3047	3048	3049	3050	3051	3052	3053	3054	3055	3056	3057	3058	3059	3060	3061	3062	3063	3064	3065	3066	3067	3068	3069	3070	3071	3072	3073	3074	3075	3076	3077	3078	3079	3080	3081	3082	3083	3084	3085	3086	3087	3088	3089	3090	3091	3092	3093	3094	3095	3096	3097	3098	3099	3100	3101	3102	3103	3104	3105	3106	3107	3108	3109	3110	3111	3112	3113	3114	3115	3116	3117	3118	3119	3120	3121	3122	3123	3124	3125	3126	3127	3128	3129	3130	3131	3132	3133	3134	3135	3136	3137	3138	3139	3140	3141	3142	3143	3144	3145	3146	3147	3148	3149
------	------	------	------	------	------	------	------	------	------	------	------	------	------	------	------	------	------	------	------	------	------	------	------	------	------	------	------	------	------	------	------	------	------	------	------	------	------	------	------	------	------	------	------	------	------	------	------	------	------	------	------	------	------	------	------	------	------	------	------	------	------	------	------	------	------	------	------	------	------	------	------	------	------	------	------	------	------	------	------	------	------	------	------	------	------	------	------	------	------	------	------	------	------	------	------	------	------	------	------	------	------	------	------	------	------	------	------	------	------	------	------	------	------	------	------	------	------	------	------	------	------	------	------	------	------	------	------	------	------	------	------	------	------	------	------	------	------	------	------	------	------	------	------	------	------	------	------	------	------	------	------	------	------	------	------	------	------	------	------	------	------	------	------	------	------	------	------	------	------

Figure A-66 METSAT AMSU-A1 1331640-1 Left Panel (W/Covers) Shell Elements

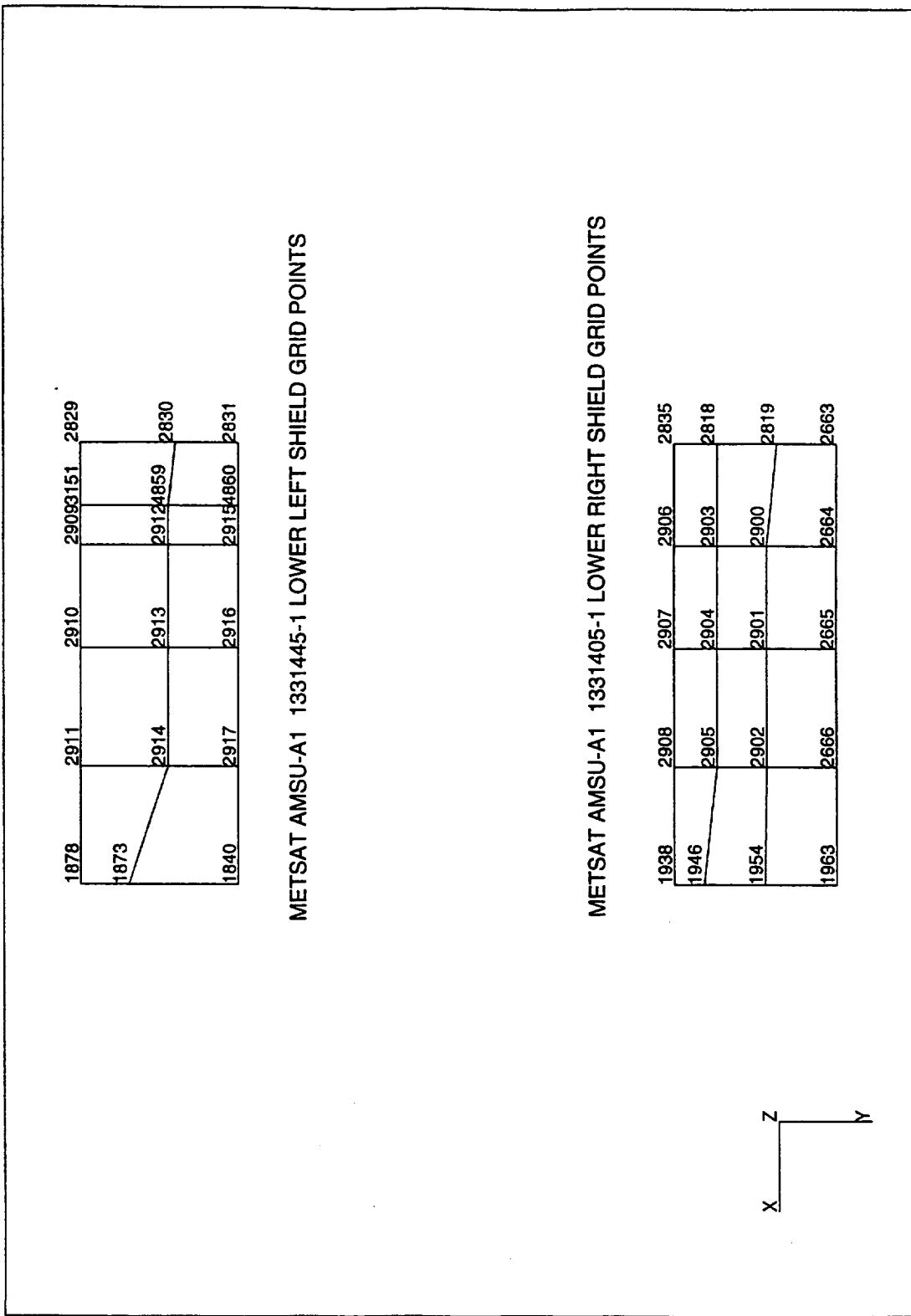

Figure A-67 METSAT AMSU-A1 1331445-1 Lower Left Shield Grid Points

Figure A-68 METSAT AMSU-A1 1331405-1 Lower Right Shield Grid Points

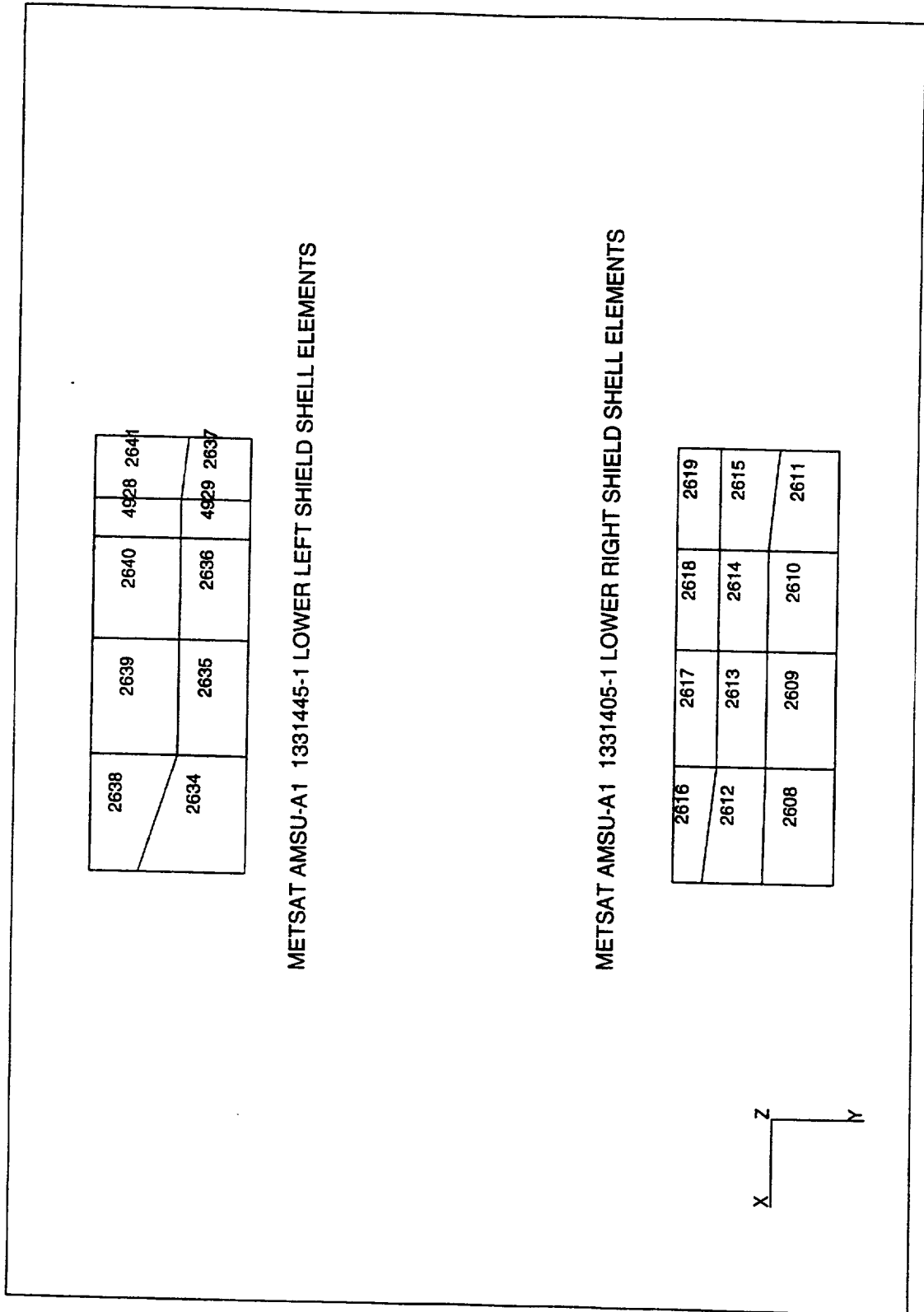

Figure A-69 METSAT AMSU-A1 1331445-1 Lower Left Shield Shell Elements

Figure A-70 METSAT AMSU-A1 1331405-1 Lower Right Shield Shell Elements

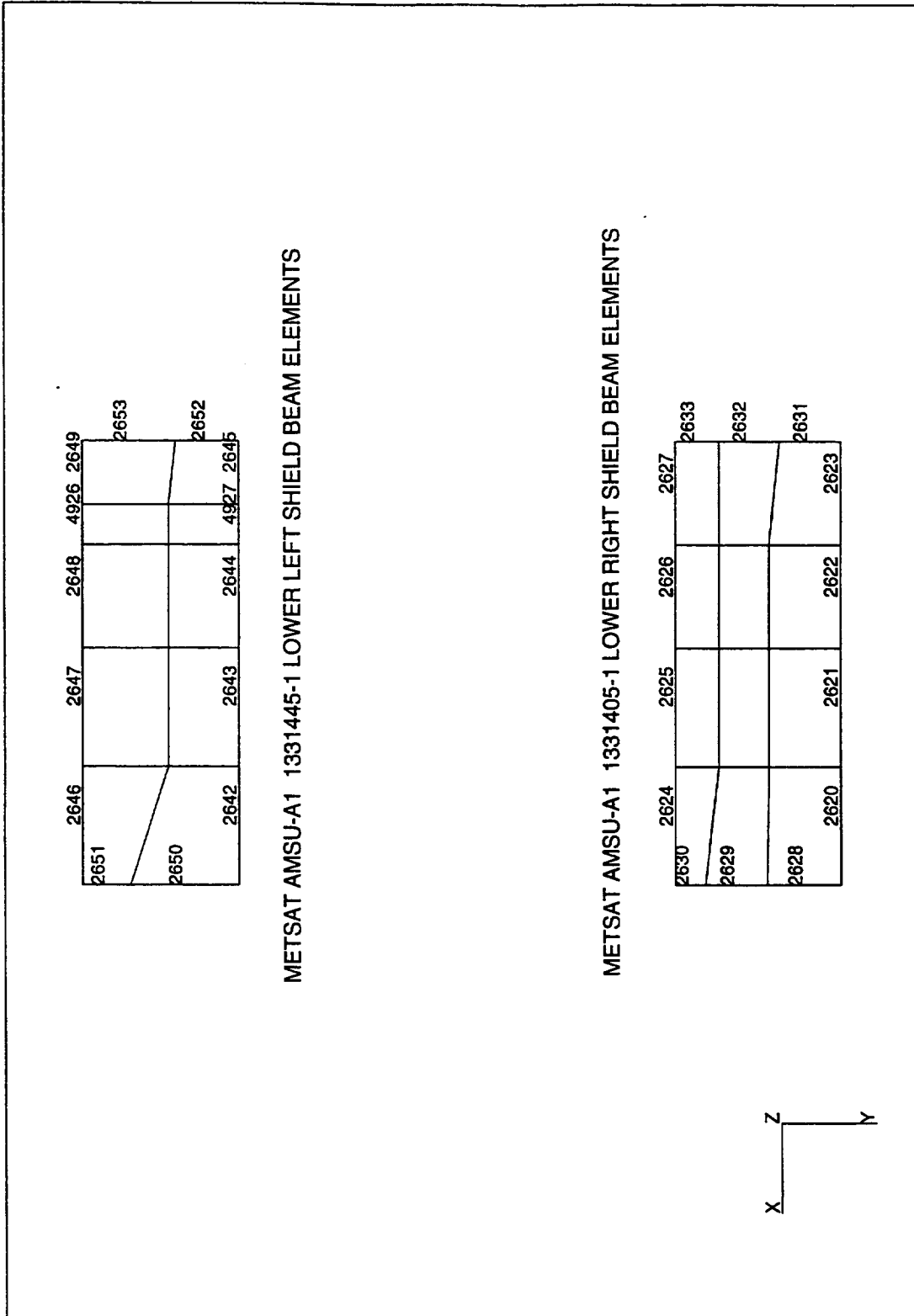

Figure A-71 METSAT AMSU-A1 1331445-1 Lower Left Shield Beam Elements

Figure A-72 METSAT AMSU-A1 1331405-1 Lower Right Shield Beam Elements

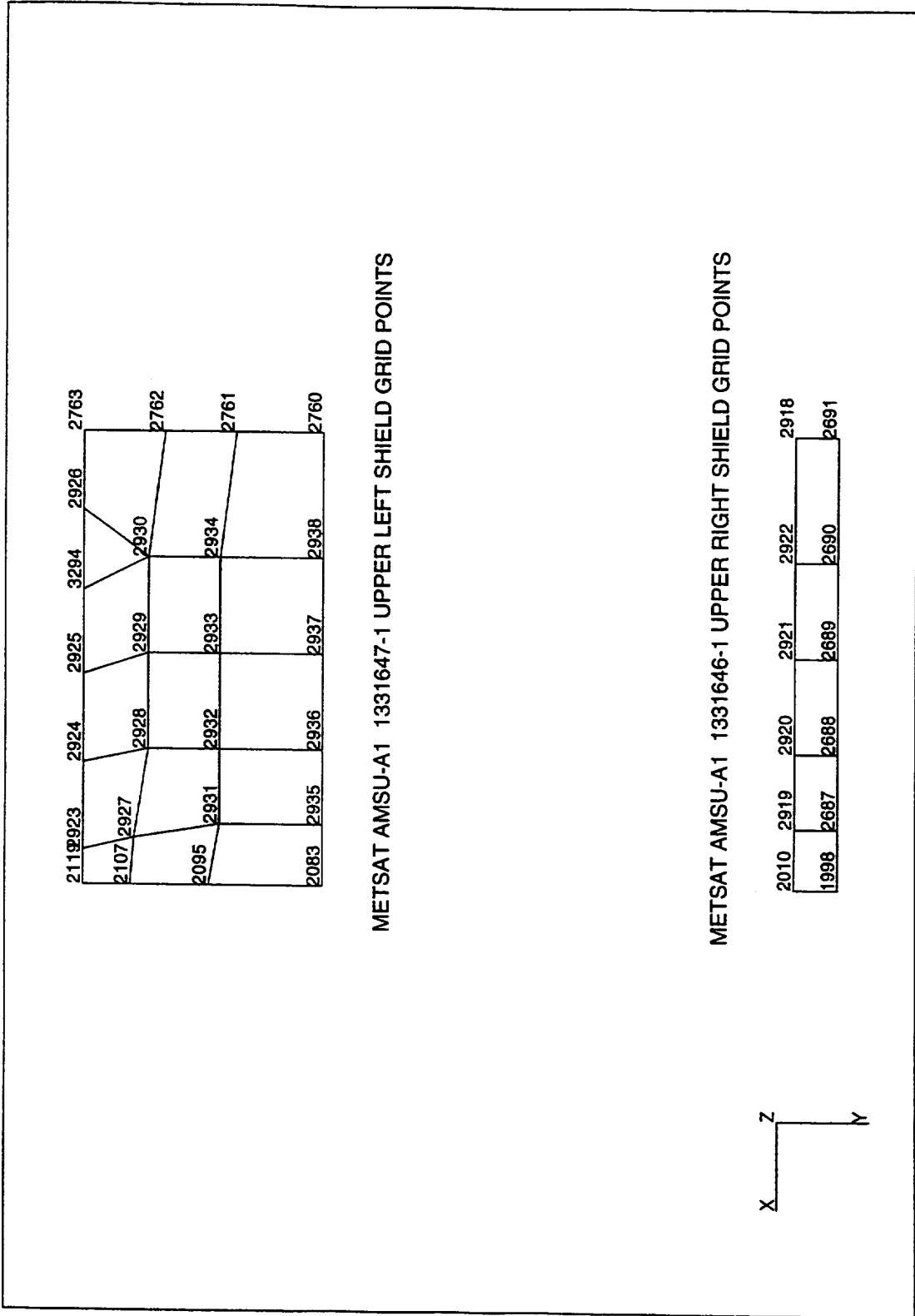

Figure A-73 METSAT AMSU-A1 1331647-1 Upper Left Shield Grid Points

Figure A-74 METSAT AMSU-A1 1331646-1 Upper Right Shield Grid Points

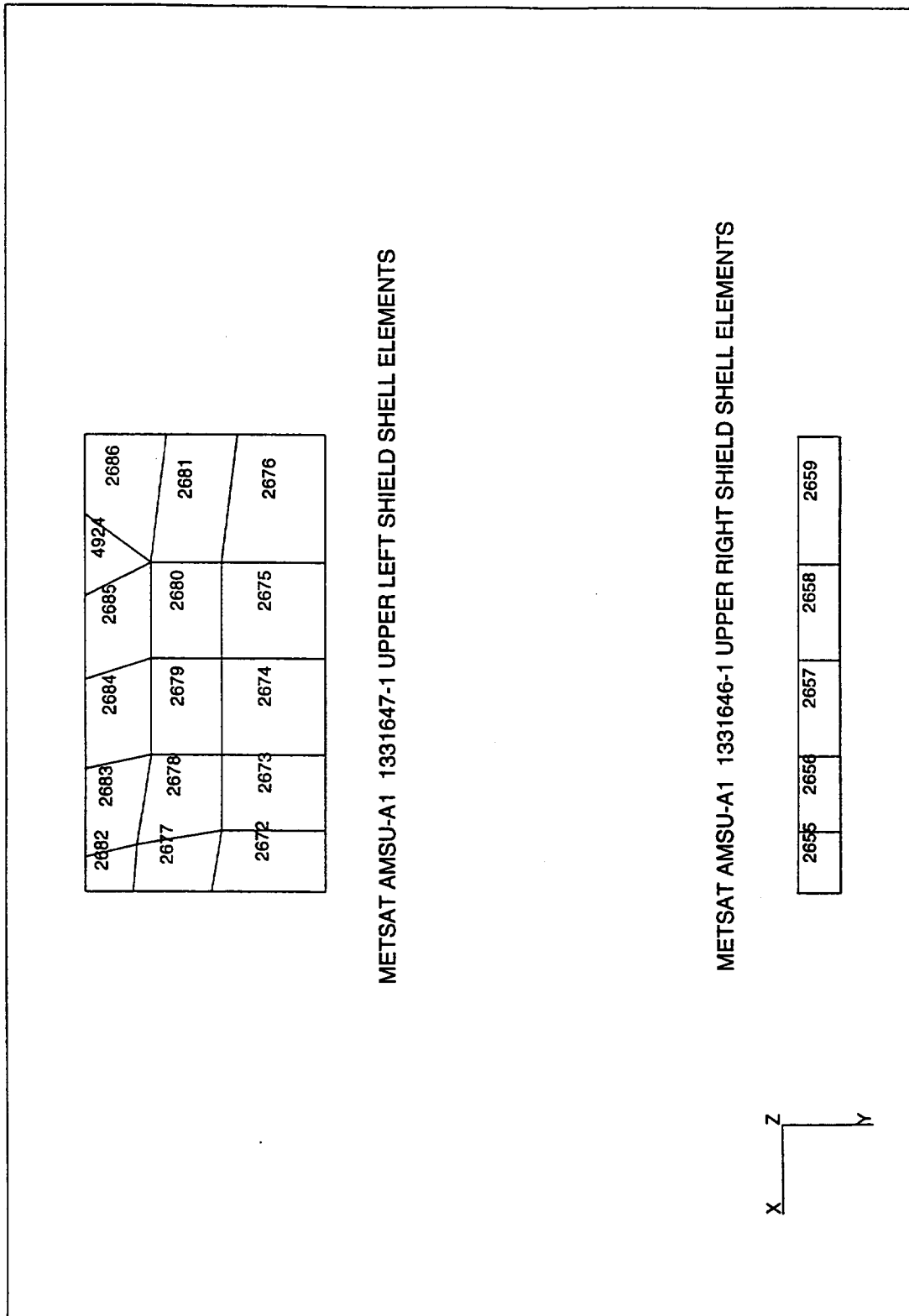

Figure A-75 METSAT AMSU-A1 1331647-1 Upper Left Shield Shell Elements
Figure A-76 METSAT AMSU-A1 1331646-1 Upper Right Shield Shell Elements

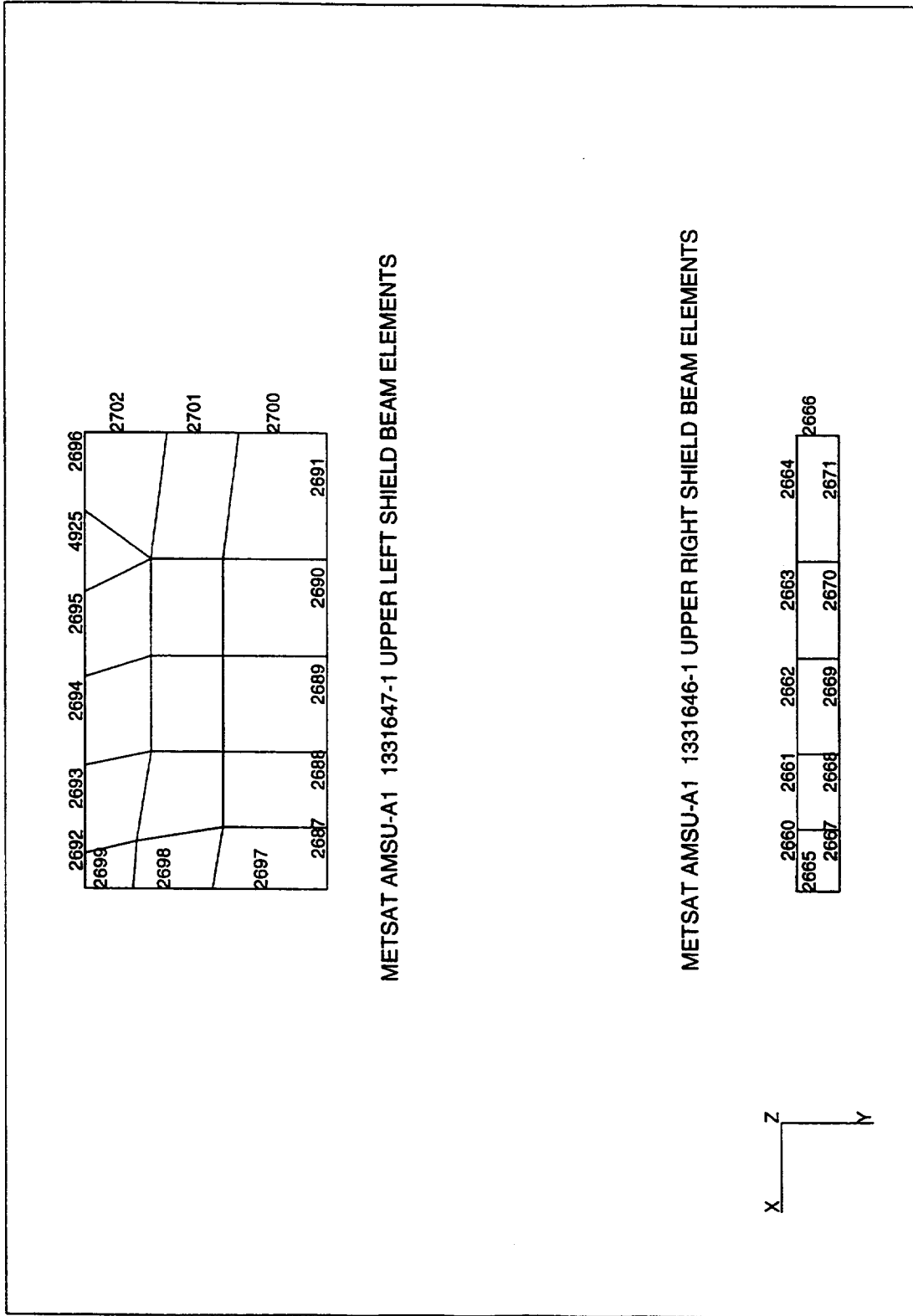

Figure A-77 METSAT AMSU-A1 1331647-1 Upper Left Shield Beam Elements

Figure A-78 METSAT AMSU-A1 1331646-1 Upper Right Shield Beam Elements

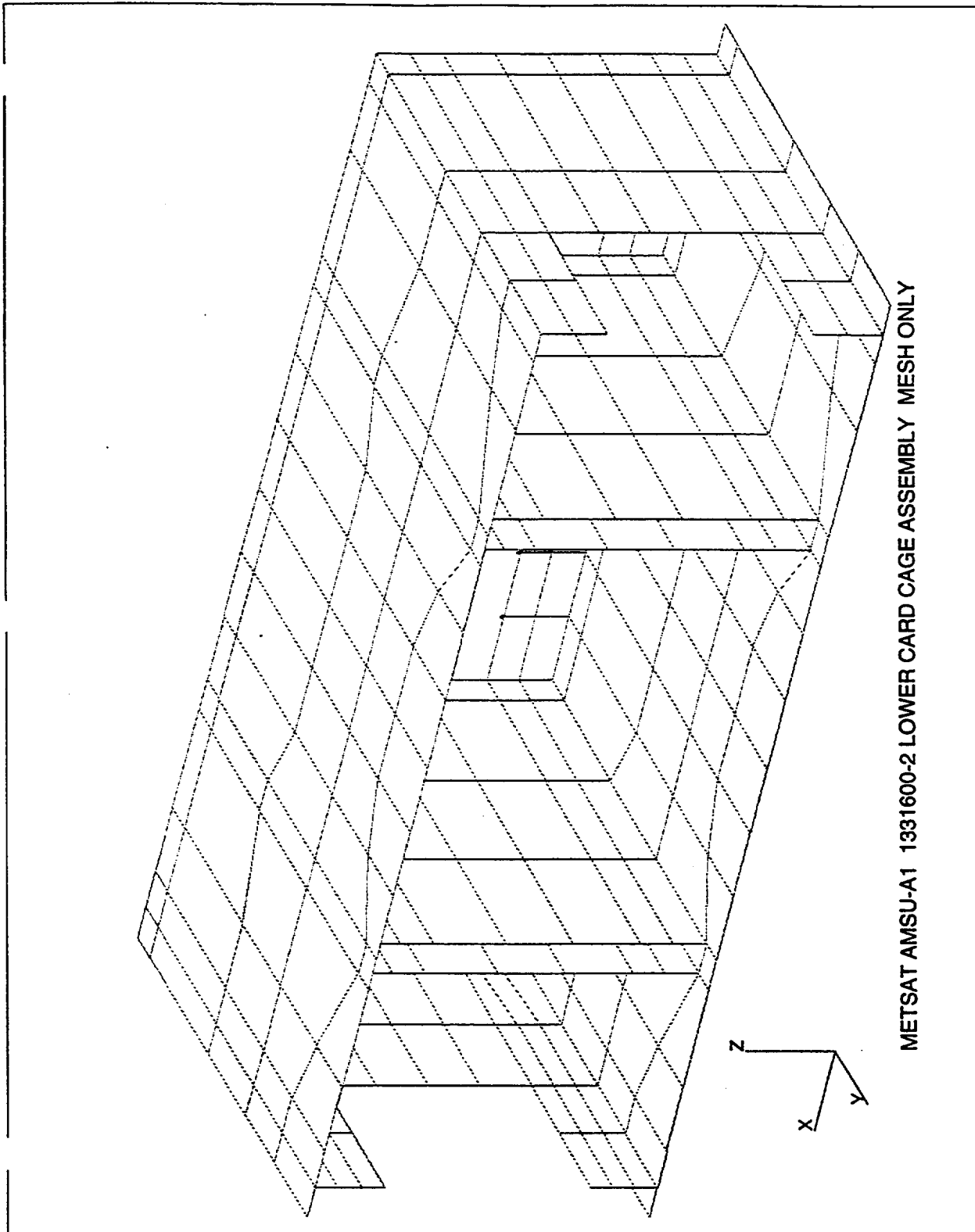

Figure A-79 METSAT AMSU-A1 1331600-2 Lower Card Cage Assembly Mesh Only

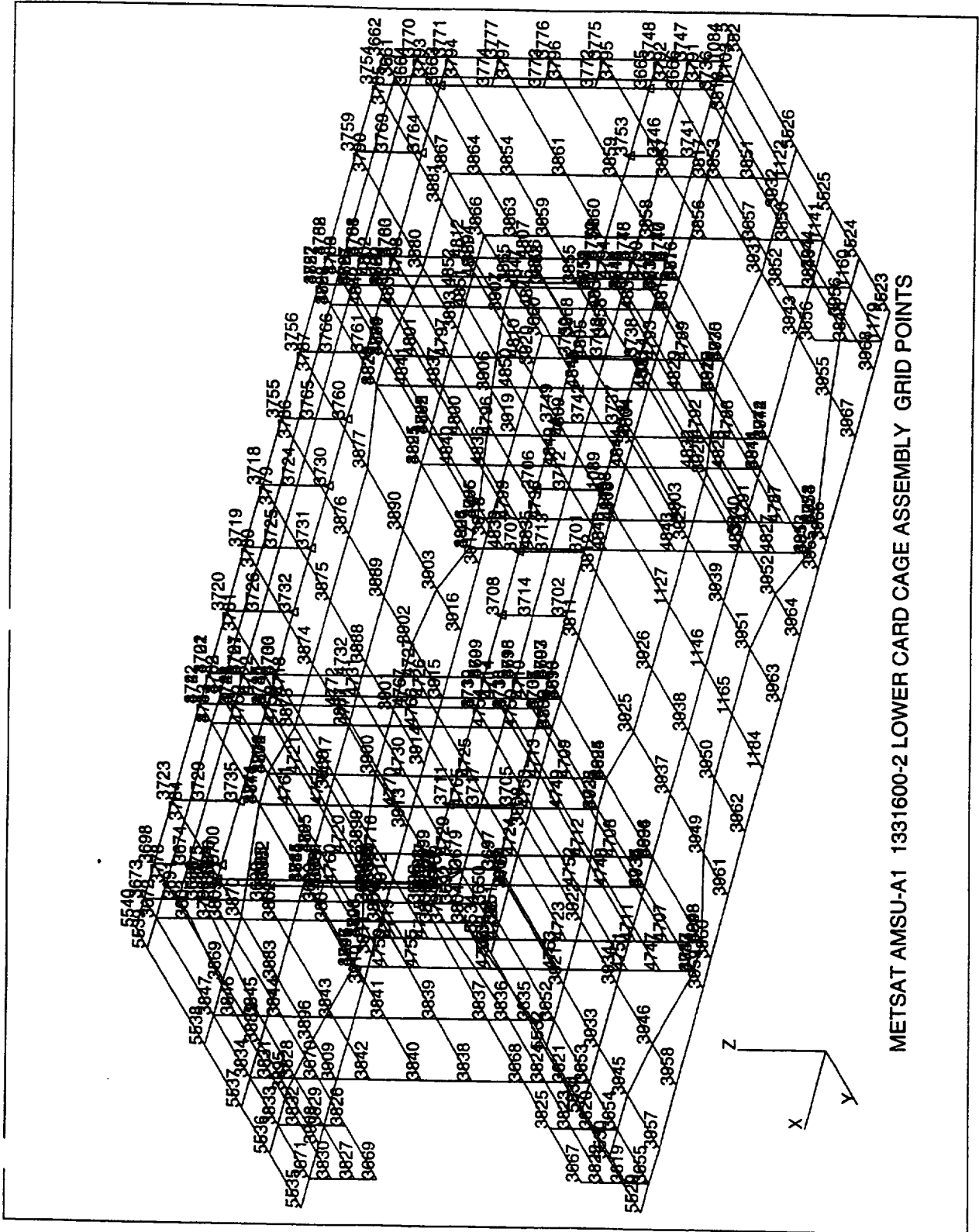

Figure A-80 METSAT AMSU-A1 1331600-2 Lower Card Cage Assembly Grid Points

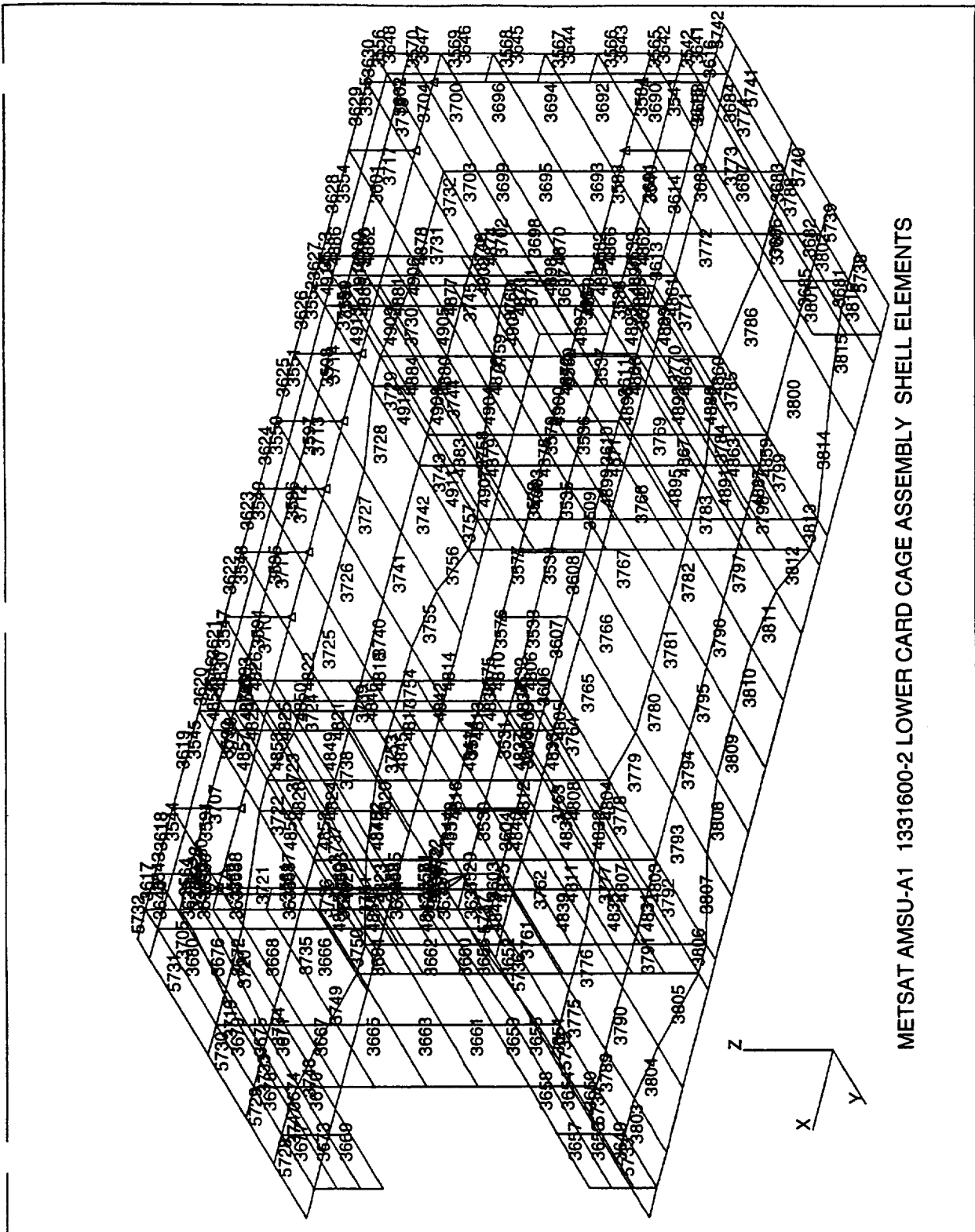
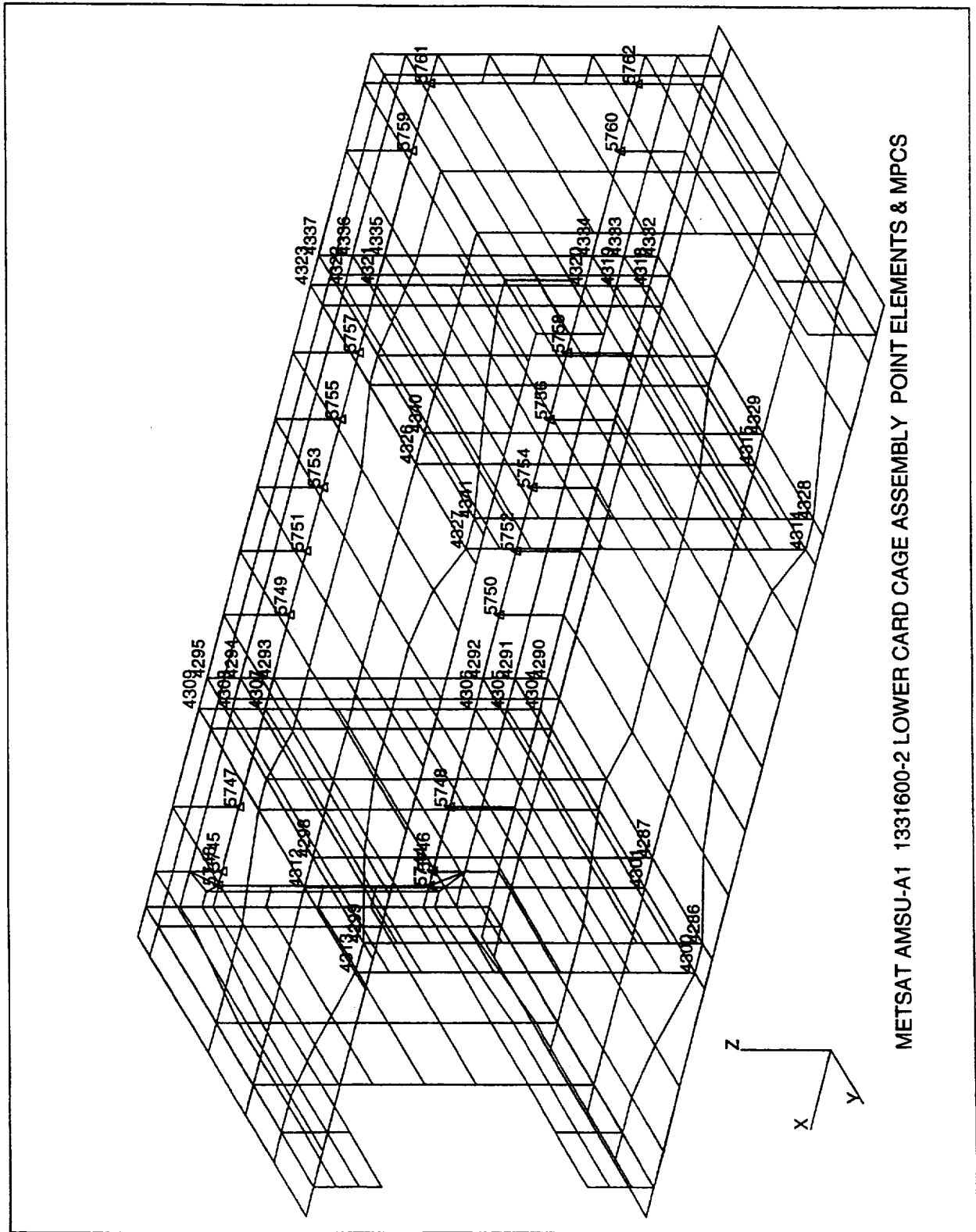

Figure A-81 METSAT AMSU-A1 1331600-2 Lower Card Cage Assembly Shell Assembly



METSAT AMSU-A1 1331600-2 LOWER CARD CAGE ASSEMBLY POINT ELEMENTS & MPCs

Figure A-82 METSAT AMSU-A1 1331600-2 Lower Card Cage Assembly Point Elements & MPCs

4826	4825	4824	4823	4822
4911	4912	4913	4914	
4839	4840	4841	4842	4821
4907	4908	4909	4910	
4835	4836	4837	4838	4820
4903	4904	4905	4906	
4848	4849	4850	4851	4852
4899	4900	4901	4902	
4843	4844	4845	4846	4847
4895	4896	4897	4898	
4837	4832	4833	4834	4819
4891	4892	4893	4894	
4827	4828	4829	4830	4818
Y	4887	4888	4889	4890
4813	4814	4815	4816	4817

METSAT AMSU-A1 1331600-1 LOWER CARD CAGE CARD 1 - GRIDS & SHELLS

Figure A-83 METSAT AMSU-A1 1331600-1 Lower Card Cage Card 1 Grids & Shells

4786	4785	4784	4783	4782
4863	4884	4885	4886	4886
4799	4800	4801	4802	4781
4795	4796	4797	4798	4882
4875	4876	4877	4878	4780
4808	4809	4810	4811	4812
4871	4872	4873	4874	4874
4803	4804	4805	4806	4807
4867	4868	4869	4870	4870
4784	4792	4793	4794	4779
4863	4864	4865	4866	4866
4787	4788	4789	4790	4778
4859	4860	4861	4862	4862
4773	4774	4775	4776	4777

METSAT AMSU-A1 1331600-1 LOWER CARD CAGE CARD 2 - GRIDS & SHELLS

Figure A-84 METSAT AMSU-A1 1331600-1 Lower Card Cage Card 2 Grids & Shells

4706	4705	4704	4703	4702
4827	4828	4829	4830	4830
4719	4720	4721	4722	4701
4823	4824	4825	4826	4826
4715	4716	4717	4718	4700
4819	4820	4821	4822	4822
4728	4729	4730	4731	4732
4815	4816	4817	4818	4818
4723	4724	4725	4726	4727
4811	4812	4813	4814	4814
4714	4712	4713	4714	4699
4807	4808	4809	4810	4810
4707	4708	4709	4710	4698
4803	4804	4805	4806	4806
4693	4694	4695	4696	4697

METSAT AMSU-A1 1331600-1 LOWER CARD CAGE CARD 3 - GRIDS & SHELLS

Figure A-85 METSAT AMSU-A1 1331600-1 Lower Card Cage Card 3 Grids & Shells

4746	4745	4744	4743	4742
4855	4856	4857	4858	
4759	4760	4761	4762	4741
4851	4852	4853	4854	
4755	4756	4757	4758	4740
4847	4848	4849	4850	
4768	4769	4770	4771	4772
4843	4844	4845	4846	
4763	4764	4765	4766	4767
4839	4840	4841	4842	
4751	4752	4753	4754	4739
4835	4836	4837	4838	
4747	4748	4749	4750	4738
4831	4832	4833	4834	
4733	4734	4735	4736	4737

METSAT AMSU-A1 1331600-1 LOWER CARD CAGE CARD 4 - GRIDS & SHELLS

Figure A-86 METSAT AMSU-A1 1331600-1 Lower Card Cage Card 4 Grids & Shells

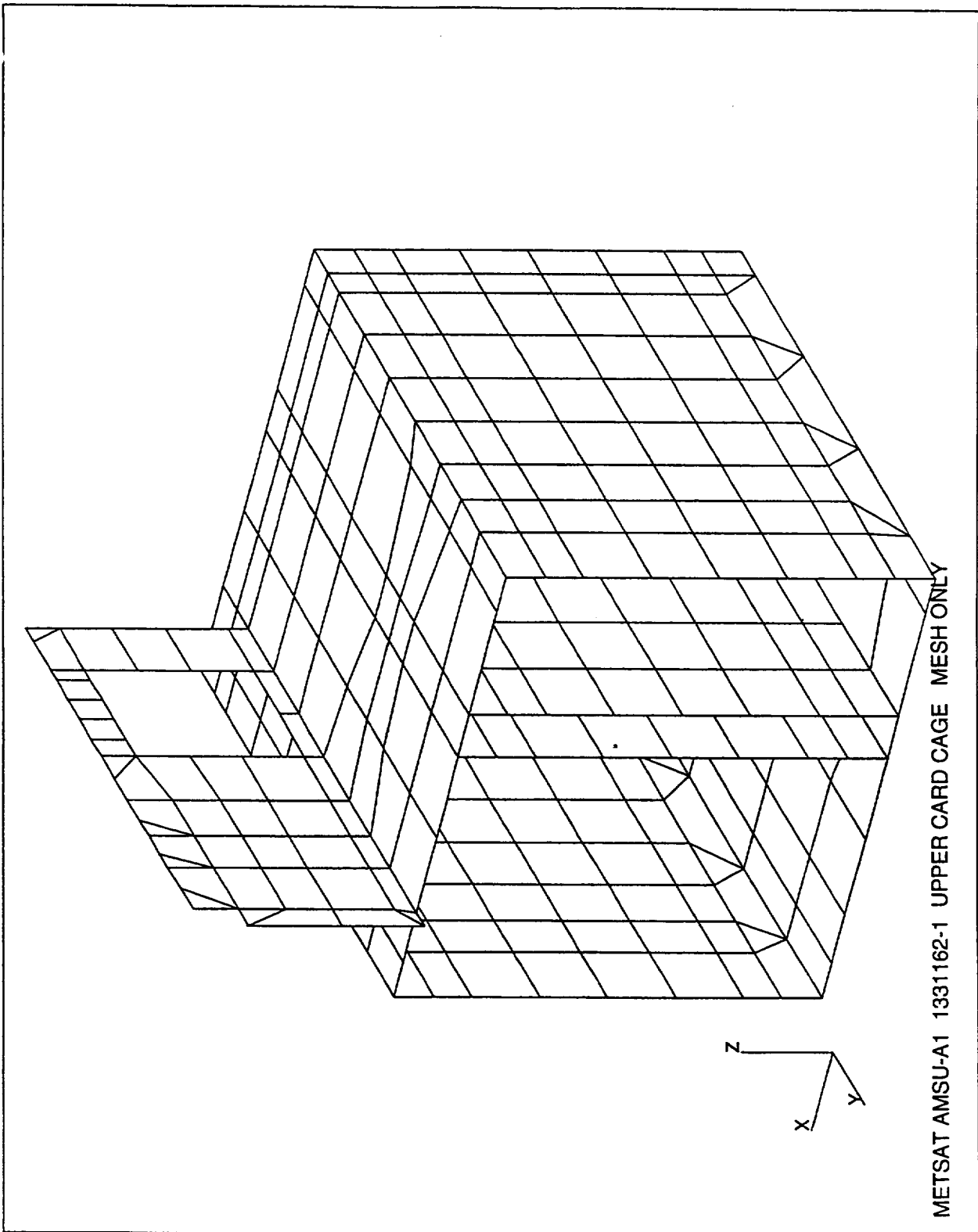

Figure A-87 METSAT AMSU-A1 1331162-1 Upper Card Cage Mesh Only

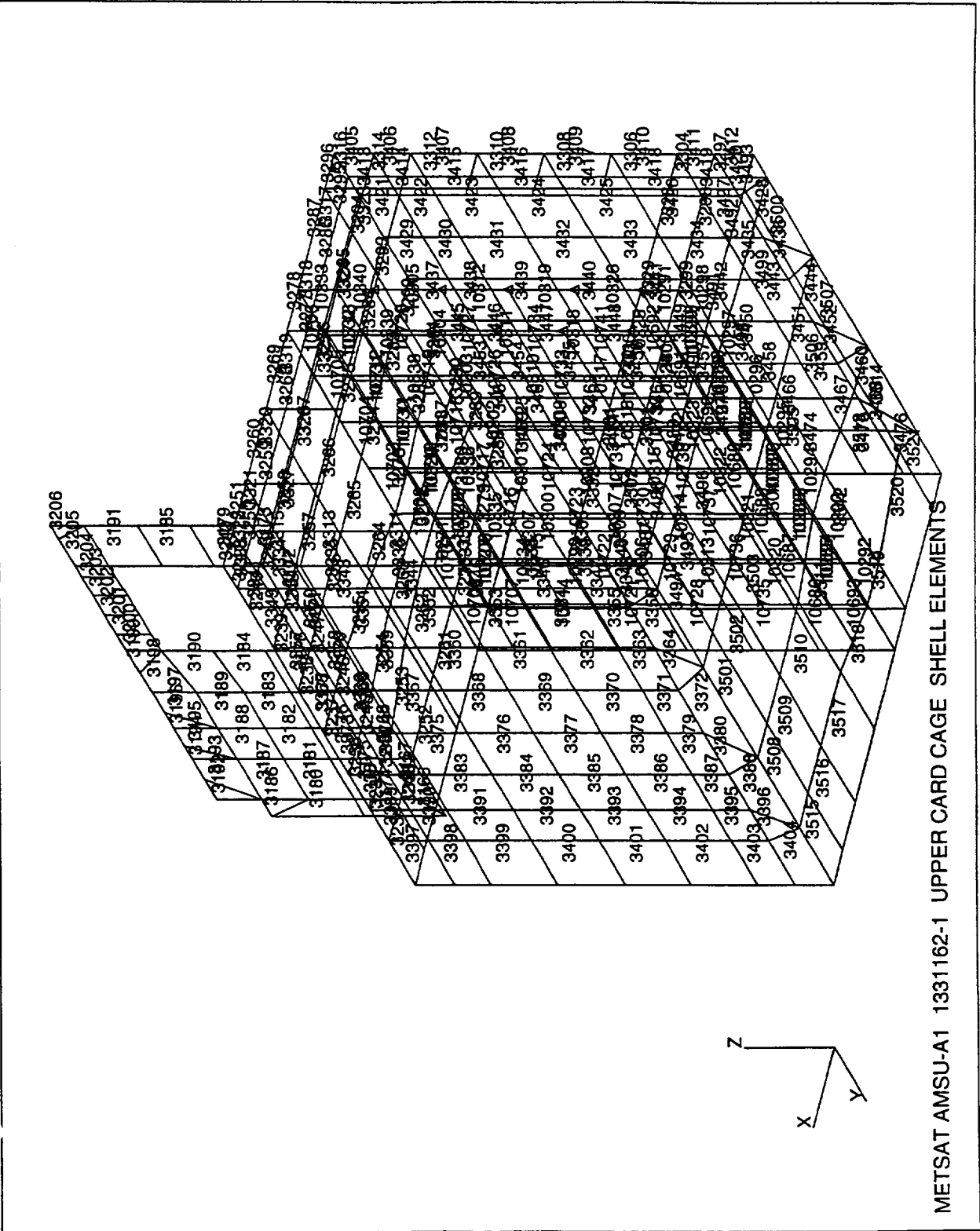

Figure A-89 METSAT AMSU-A1 1331162-1 Upper Card Cage Shell Elements

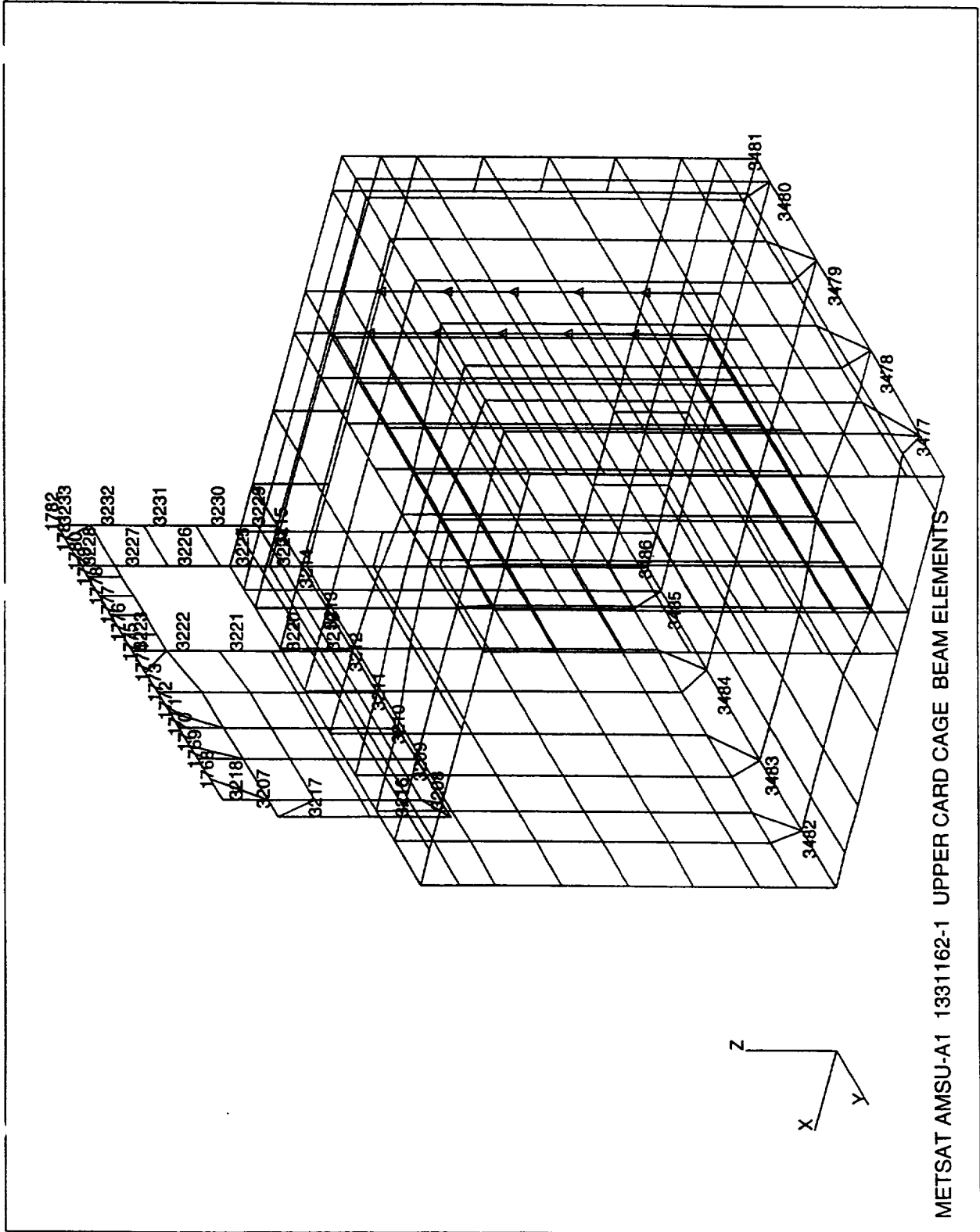

Figure A-90 METSAT AMSU-A1 1331162-1 Upper Card Cage Beam Elements

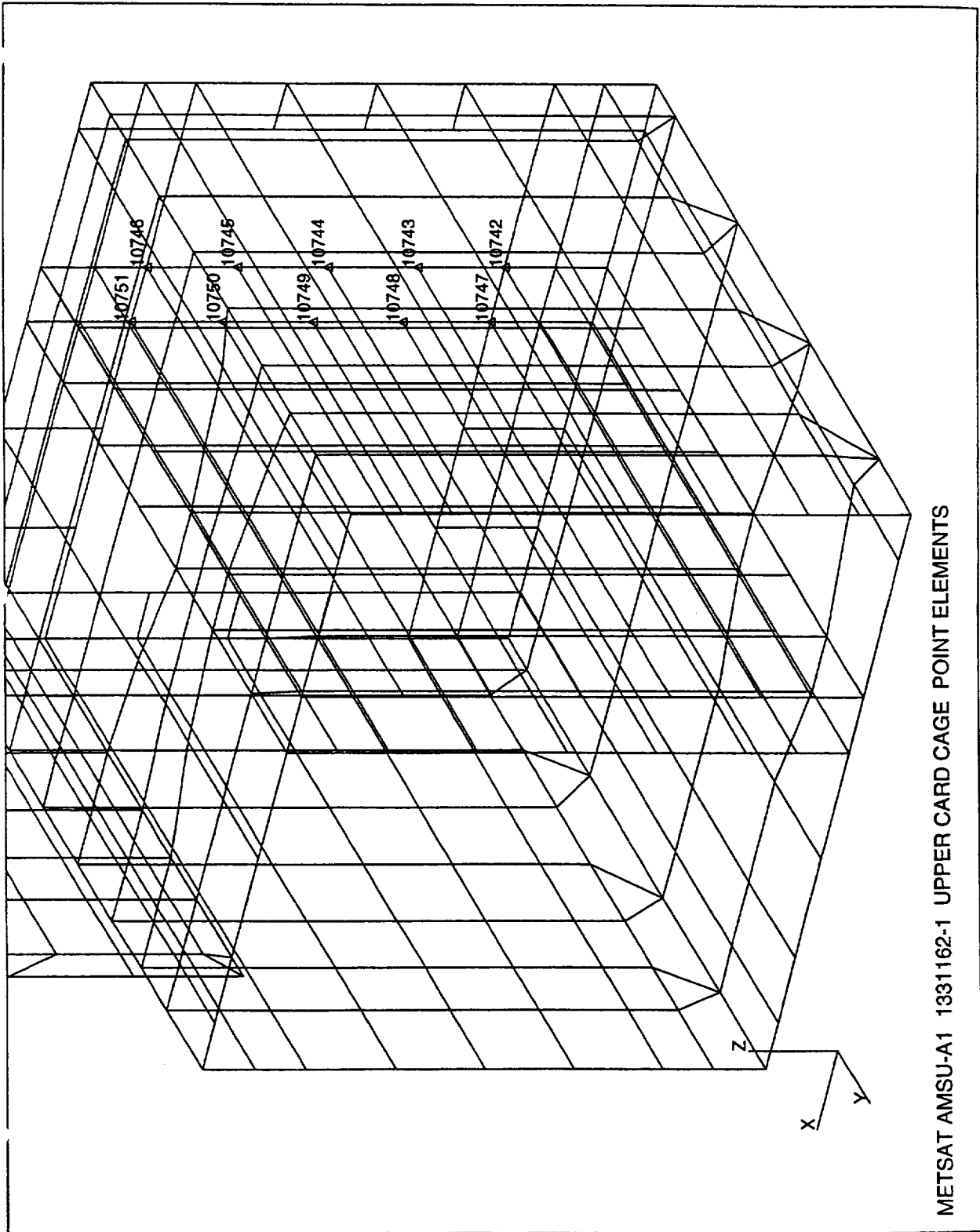
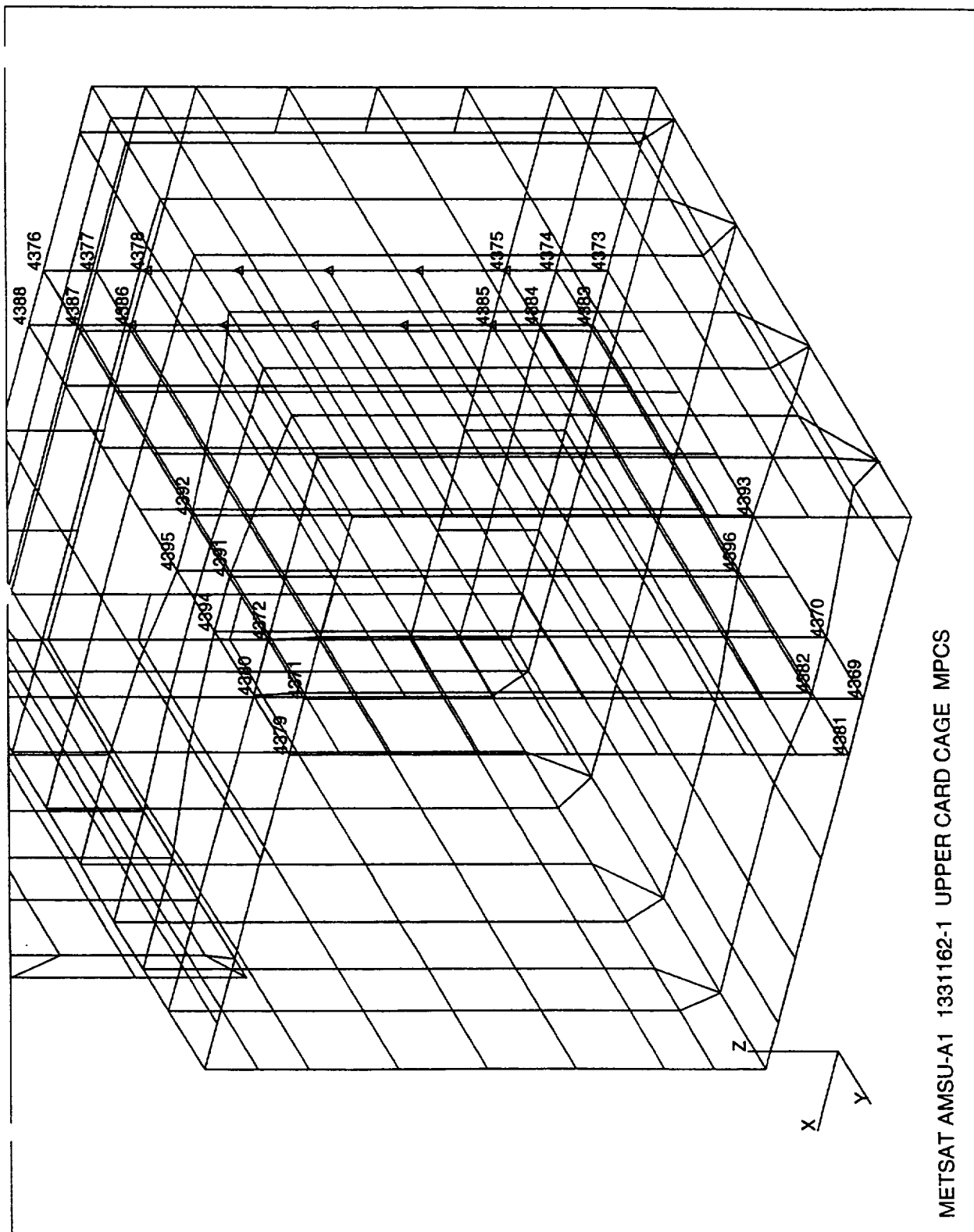

Figure A-91 METSAT AMSU-A1 1331162-1 Upper Card Cage Point Elements



METSAT AMSU-A1 1331162-1 UPPER CARD CAGE MPCS

Figure A-92 METSAT AMSU-A1 1331162-1 Upper Card Cage MPCS

11836	11837	11838	11839	11840	11841	11842	11251
10700	10701	10702	10703	10704	10705	10706	
11844	11845	11846	11847	11848	11849	11850	11259
10707	10708	10709	10710	10711	10712	10713	
11852	11853	11854	11855	11856	11857	11858	11211
10714	10715	10716	10717	10718	10719	10720	
11867	11868	11869	11870	11871	11872	11873	11874
10721	10722	10723	10724	10725	10726	10727	
11875	11876	11877	11878	11879	11880	11881	11882
10728	10729	10730	10731	10732	10733	10734	
11883	11884	11885	11886	11887	11888	11889	11890
10735	10736	10737	10738	10739	10740	10741	
11813	11814	11815	11816	11817	11818	11819	11187
10686	10687	10688	10689	10690	10691	10692	
11821	11822	11823	11824	11825	11826	11827	11195
10693	10694	10695	10696	10697	10698	10699	
11829	11830	11831	11832	11833	11834	11835	11203

METSAT AMSU-A1 1331162-1 UPPER CARD CAGE CARD (+X) GRIDS & SHELLS

Figure A-93 METSAT AMSU-A1 1331162-1 Upper Card Cage Card (+X) Grids & Shells

11332	11333	11334	11335	11336	11337	11338	11339
10327	10328	10329	10330	10331	10332	10333	
11340	11341	11342	11343	11344	11345	11346	11347
10334	10335	10336	10337	10338	10339	10340	
11292	11293	11294	11295	11296	11297	11298	11299
10299	10300	10301	10302	10303	10304	10305	
11300	11301	11302	11303	11304	11305	11306	11307
10306	10307	10308	10309	10310	10311	10312	
11308	11309	11310	11311	11312	11313	11314	11315
10313	10314	10315	10316	10317	10318	10319	
11316	11317	11318	11319	11320	11321	11322	11323
10320	10321	10322	10323	10324	10325	10326	
11268	11269	11270	11271	11272	11273	11274	11275
Z							
10285	10286	10287	10288	10289	10290	10291	
11276	11277	11278	11279	11280	11281	11282	11283
Y							
10292	10293	10294	10295	10296	10297	10298	
11284	11285	11286	11287	11288	11289	11290	11291

METSAT AMSU-A1 1331162-1 UPPER CARD CAGE DARD (-X) GRIDS & SHELLS

Figure A-94 METSAT AMSU-A1 1331162-1 Upper Card Cage Card (-X) Grids & Shells

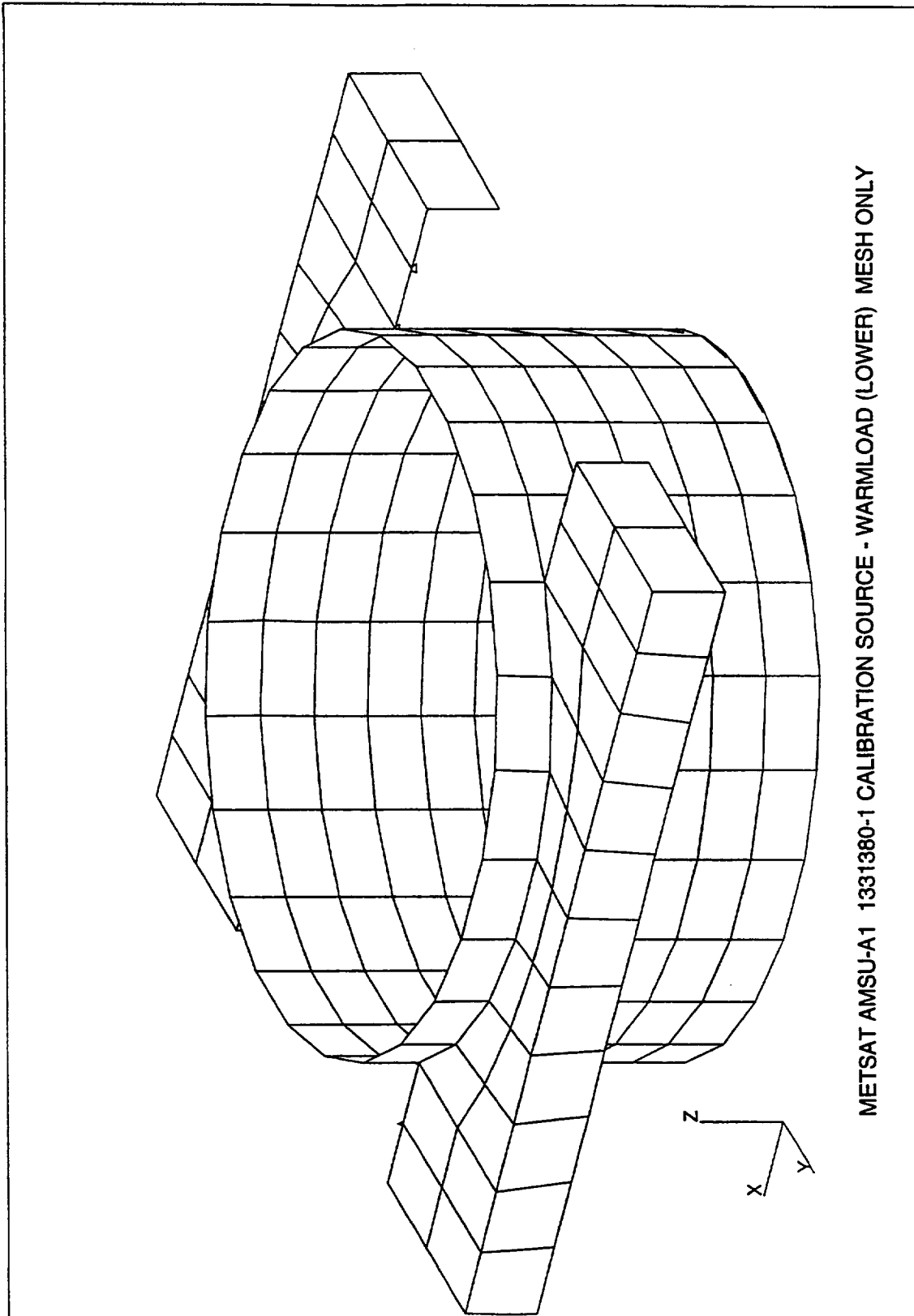

Figure A-95 METSAT AMSU-A1 1331380-1 Calibration Source-Warmload (Lower) Mesh Only

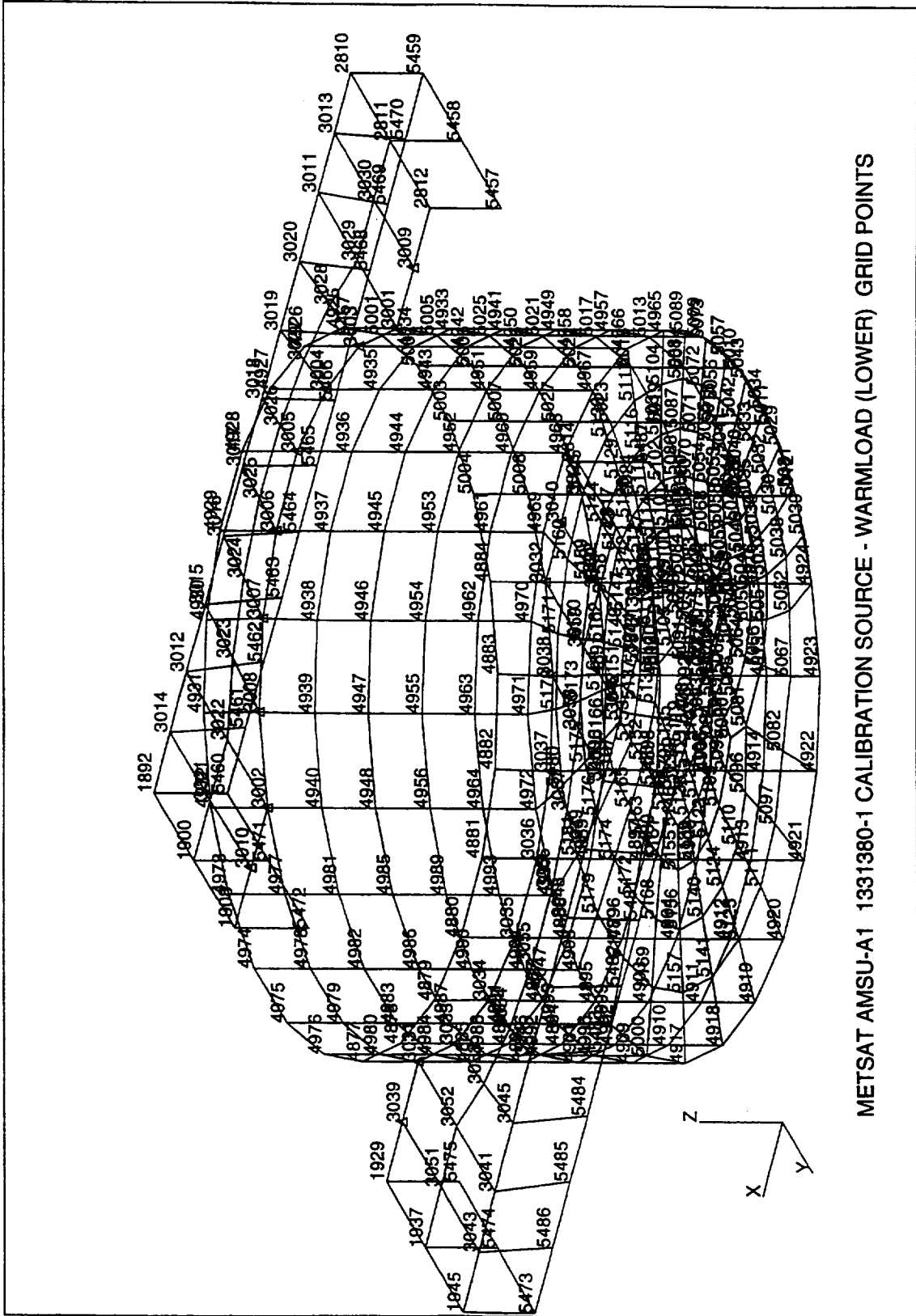
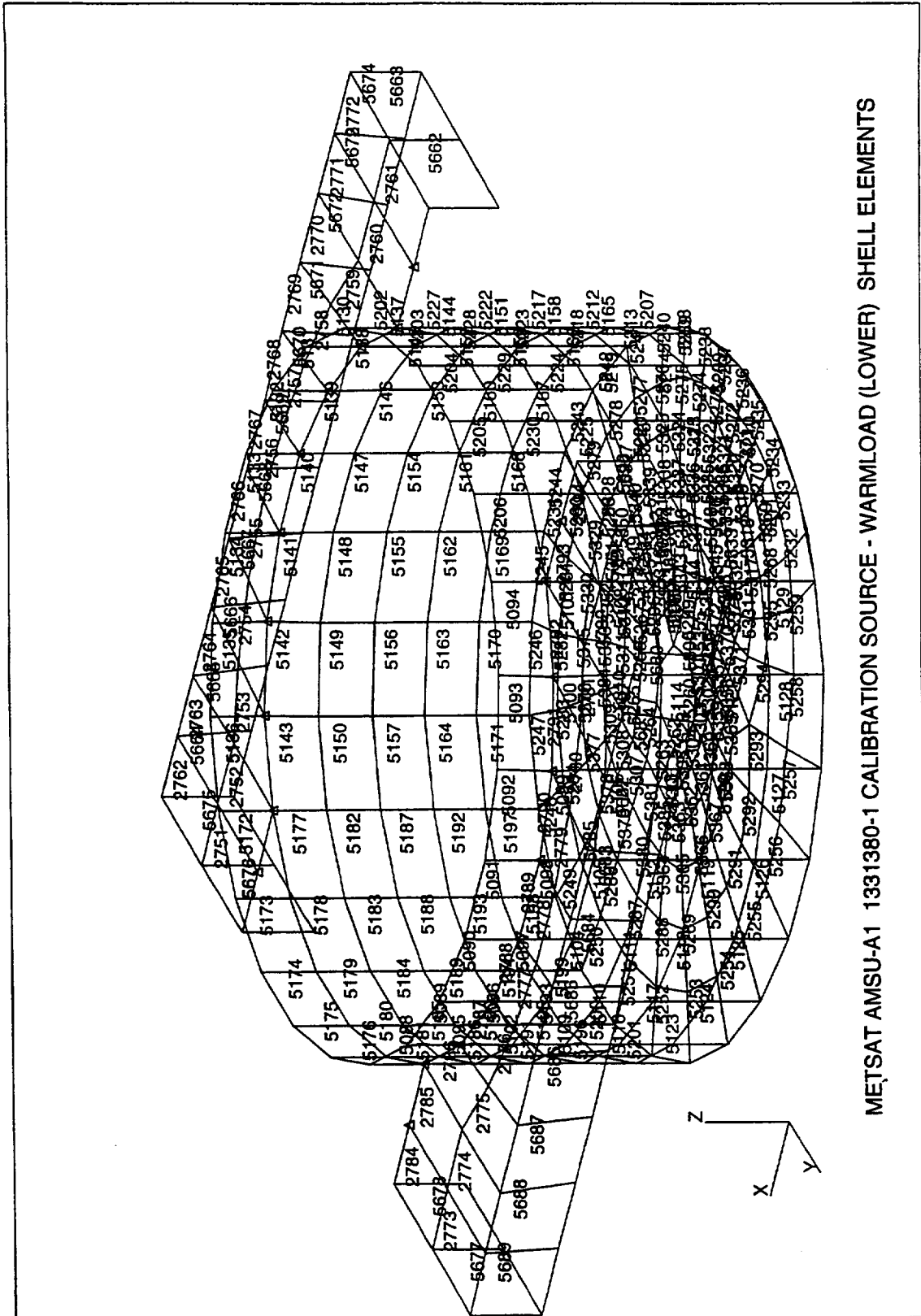

Figure A-96 METSAT AMSU-A1 1331380-1 Calibration Source-Warmload (Lower) Grid Points



METSAT AMSU-A1 1331380-1 CALIBRATION SOURCE - WARMLOAD (LOWER) SHELL ELEMENTS

Figure A-97 METSAT AMSU-A1 1331380-1 Calibration Source-Warmload (Lower) Shell Elements

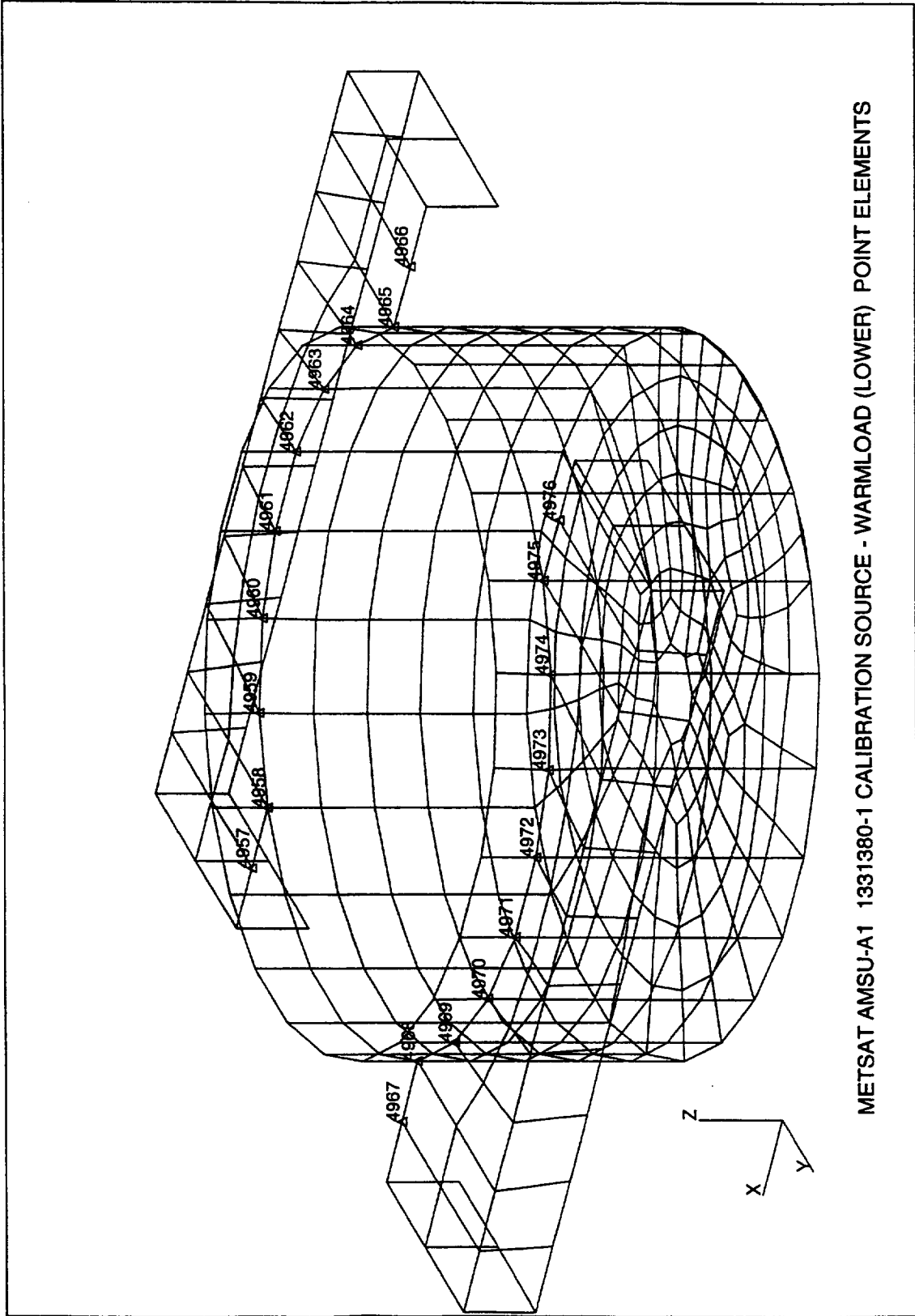

Figure A-98 METSAT AMSU-A1 1331380-1 Calibration Source-Warmload (Lower) Point Elements

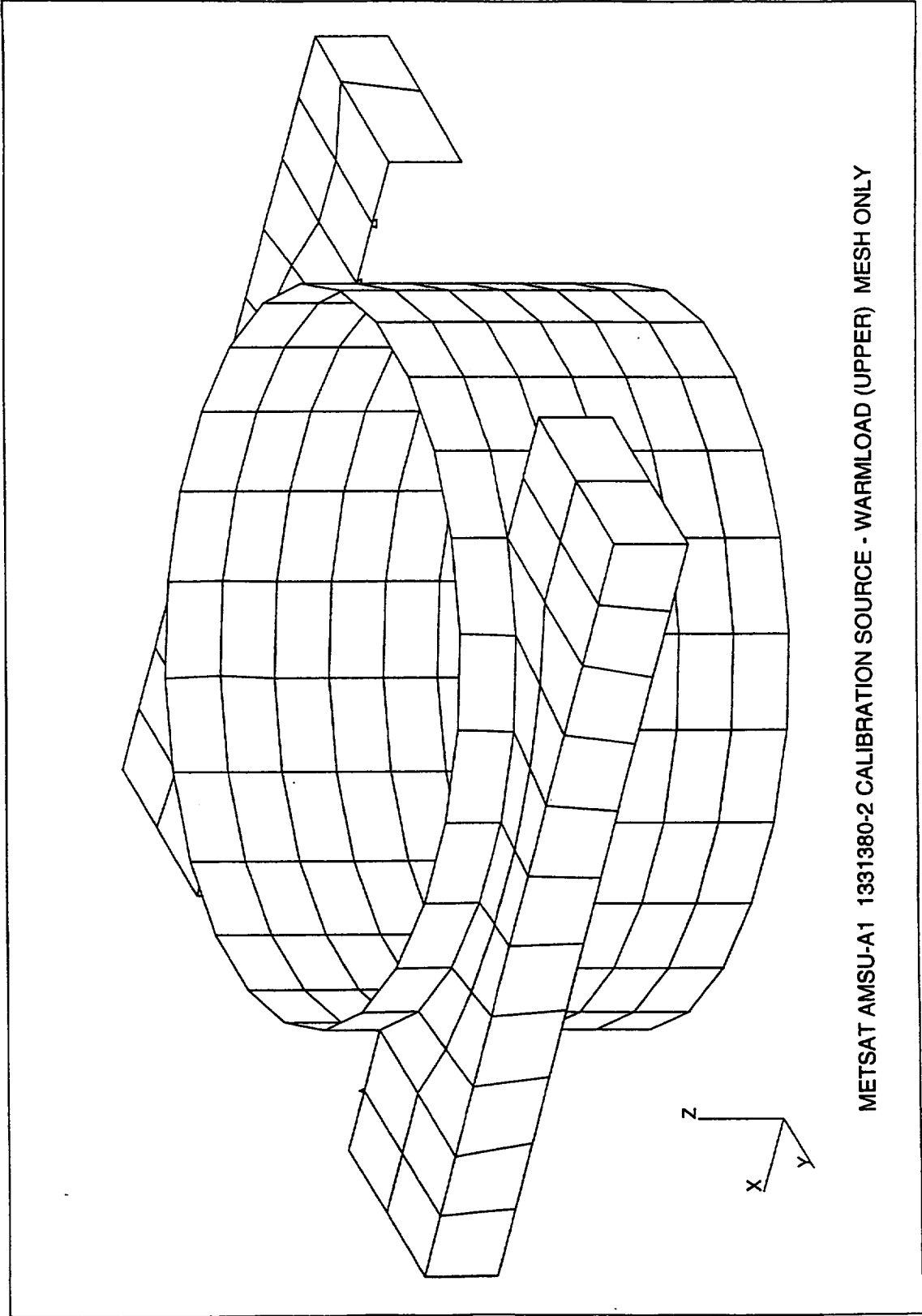
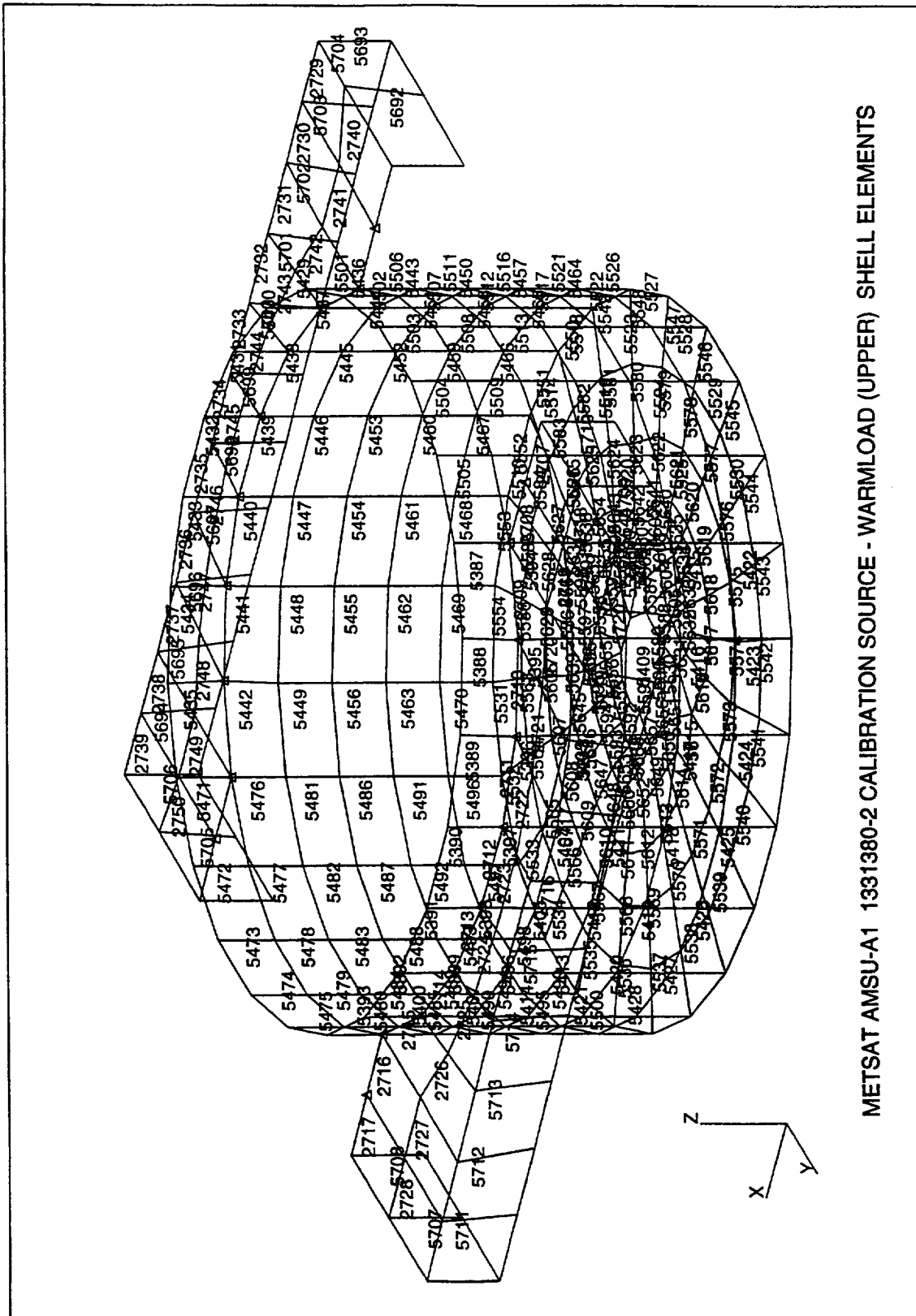

Figure A-99 METSAT AMSU-A1 1331380-2 Calibration Source-Warmload (Upper) Mesh Only



METSAT AMSU-A1 1331380-2 CALIBRATION SOURCE - WARMLOAD (UPPER) SHELL ELEMENTS

Figure A-101 METSAT AMSU-A1 1331380-2 Calibration Source-Warmload (Upper) Shell Elements

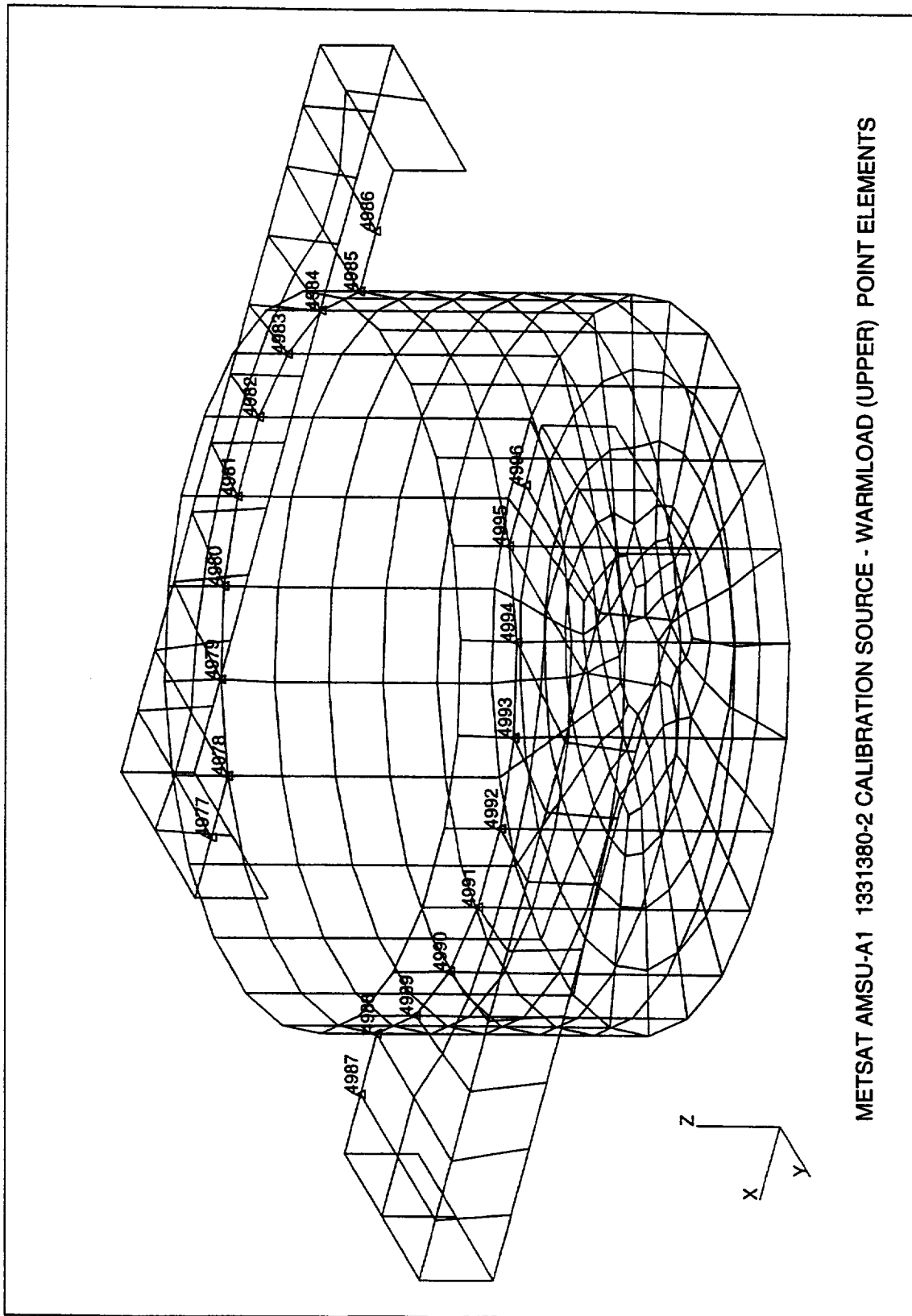

Figure A-102 METSAT AMSU-A1 1331380-2 Calibration Source-Warmload (Upper) Point Elements

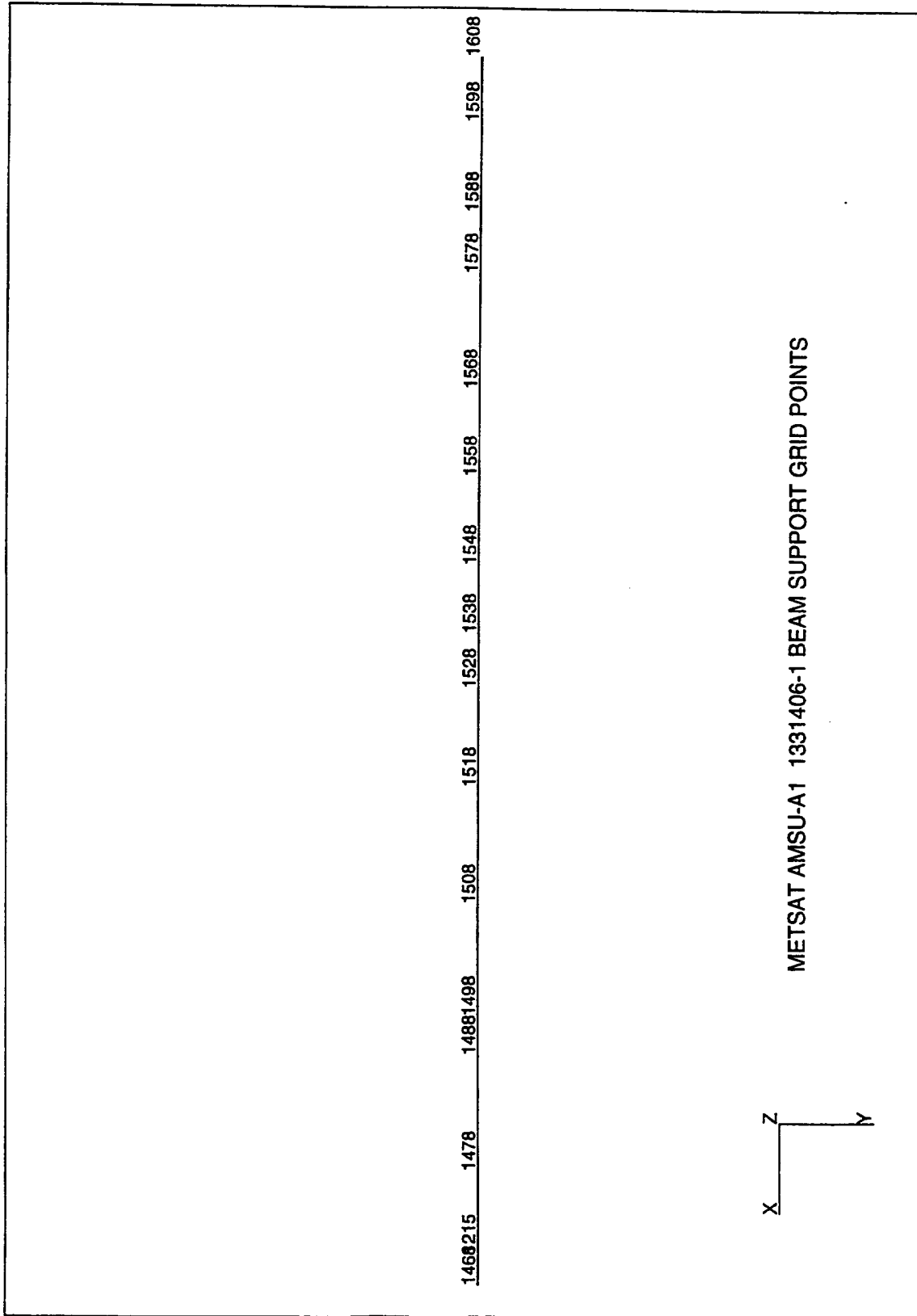

Figure A-103 METSAT AMSU-A1 1331406-1 Beam Support Grid Points

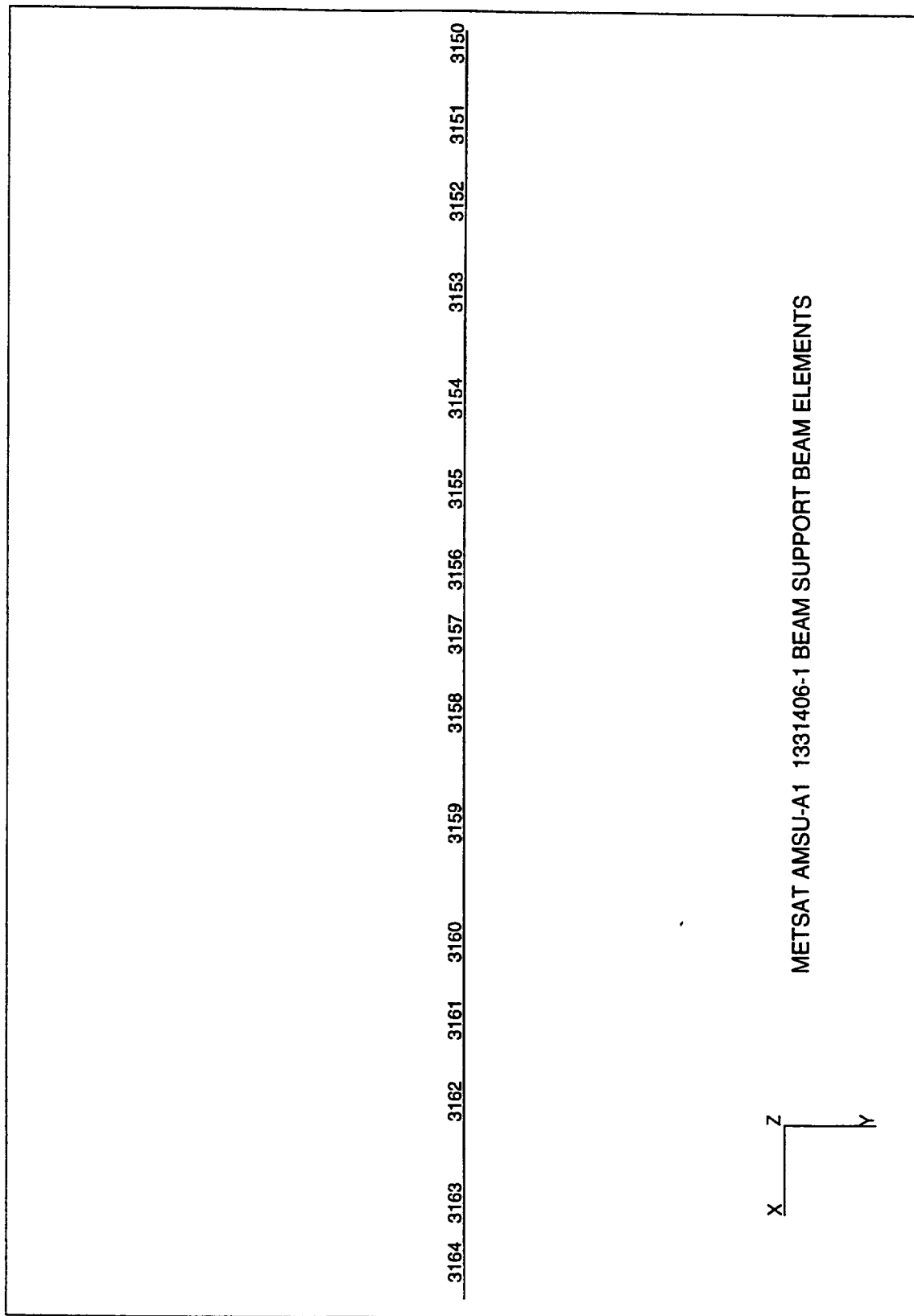

Figure A-104 METSAT AMSU-A1 1331406-1 Beam Support Beam Elements

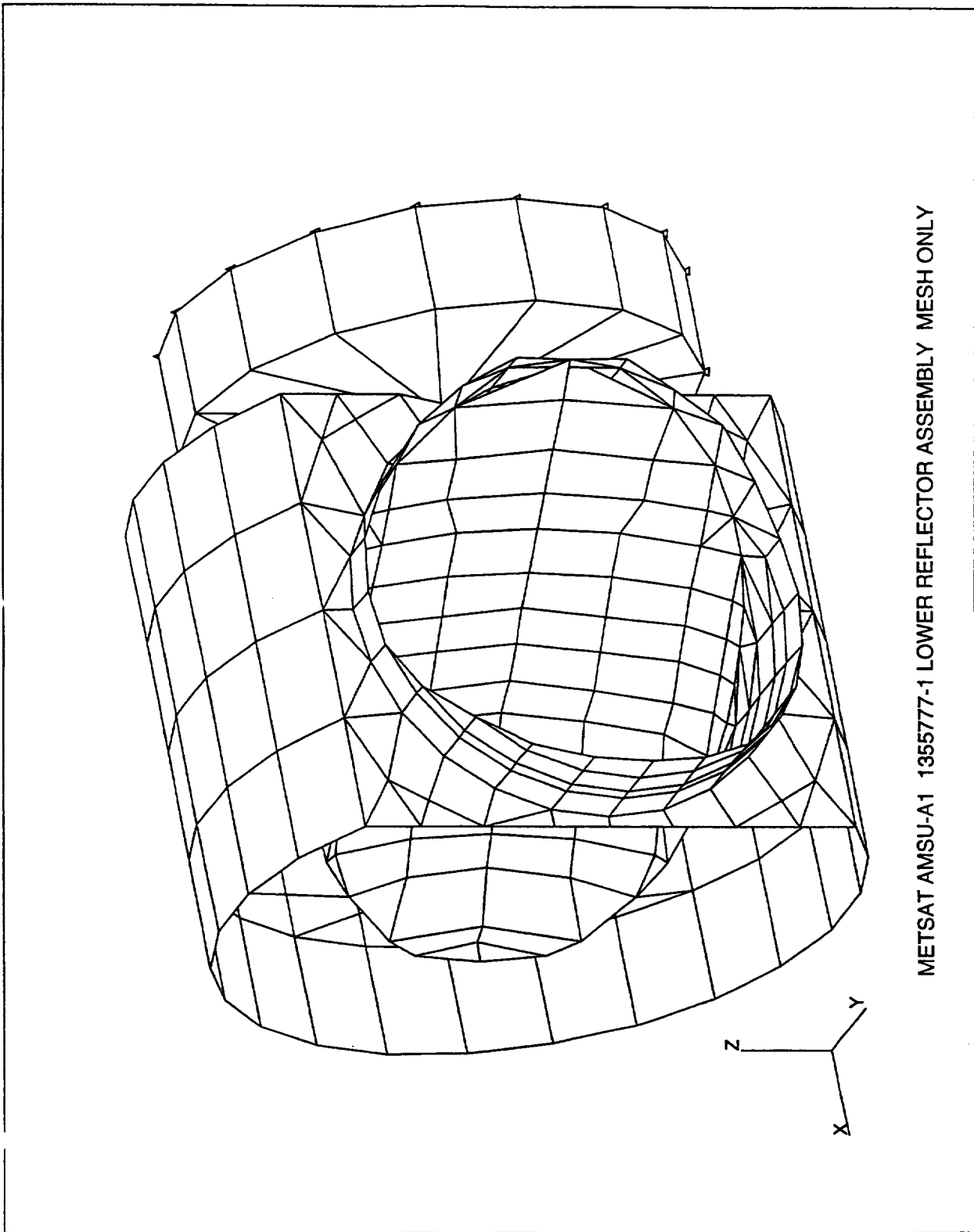

Figure A-105 METSAT AMSU-A1 1355777-1 Lower Reflector Assembly Mesh Only

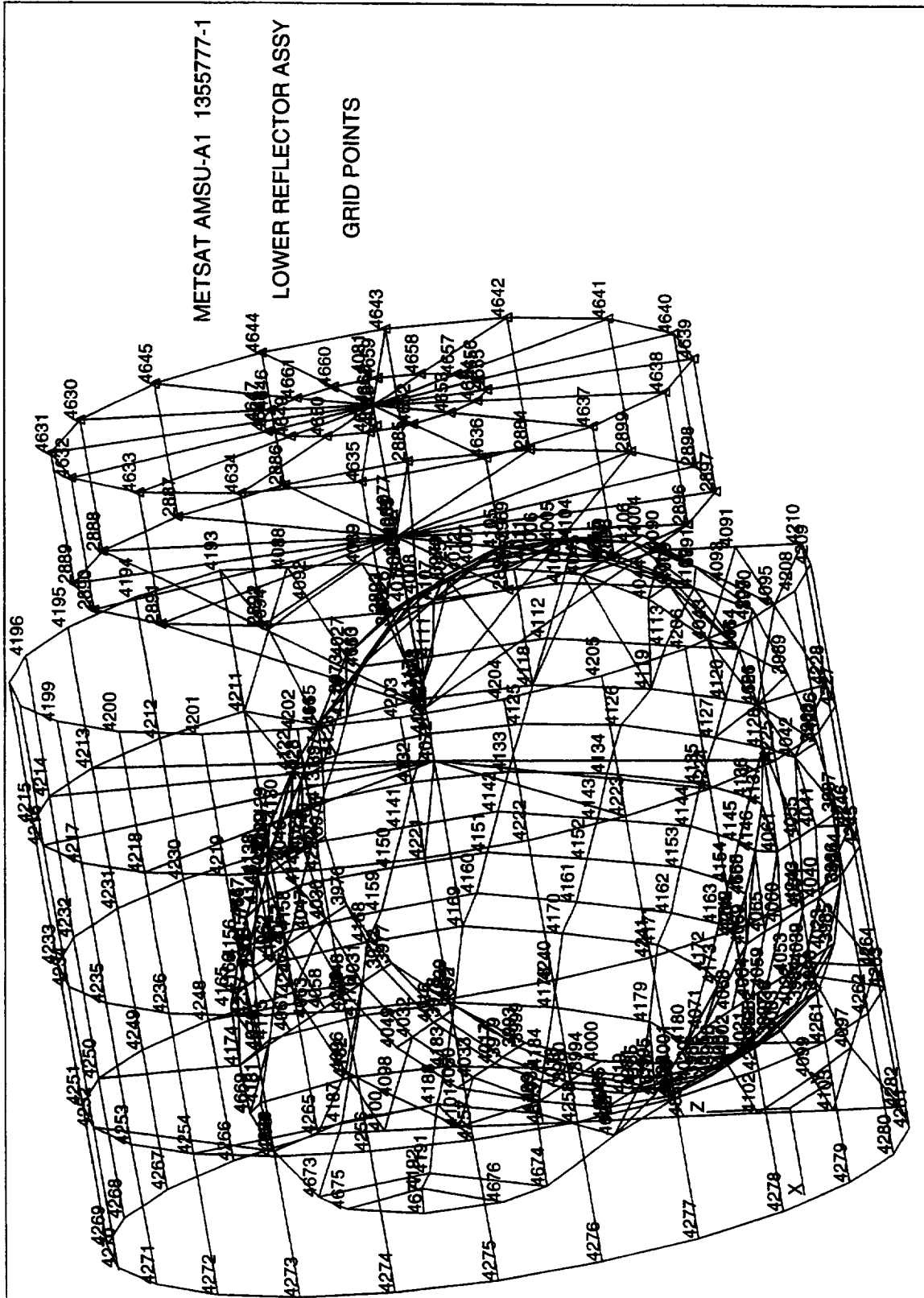

Figure A-106 METSAT AMSU-A1 1355777-1 Lower Reflector Assembly Grid Points

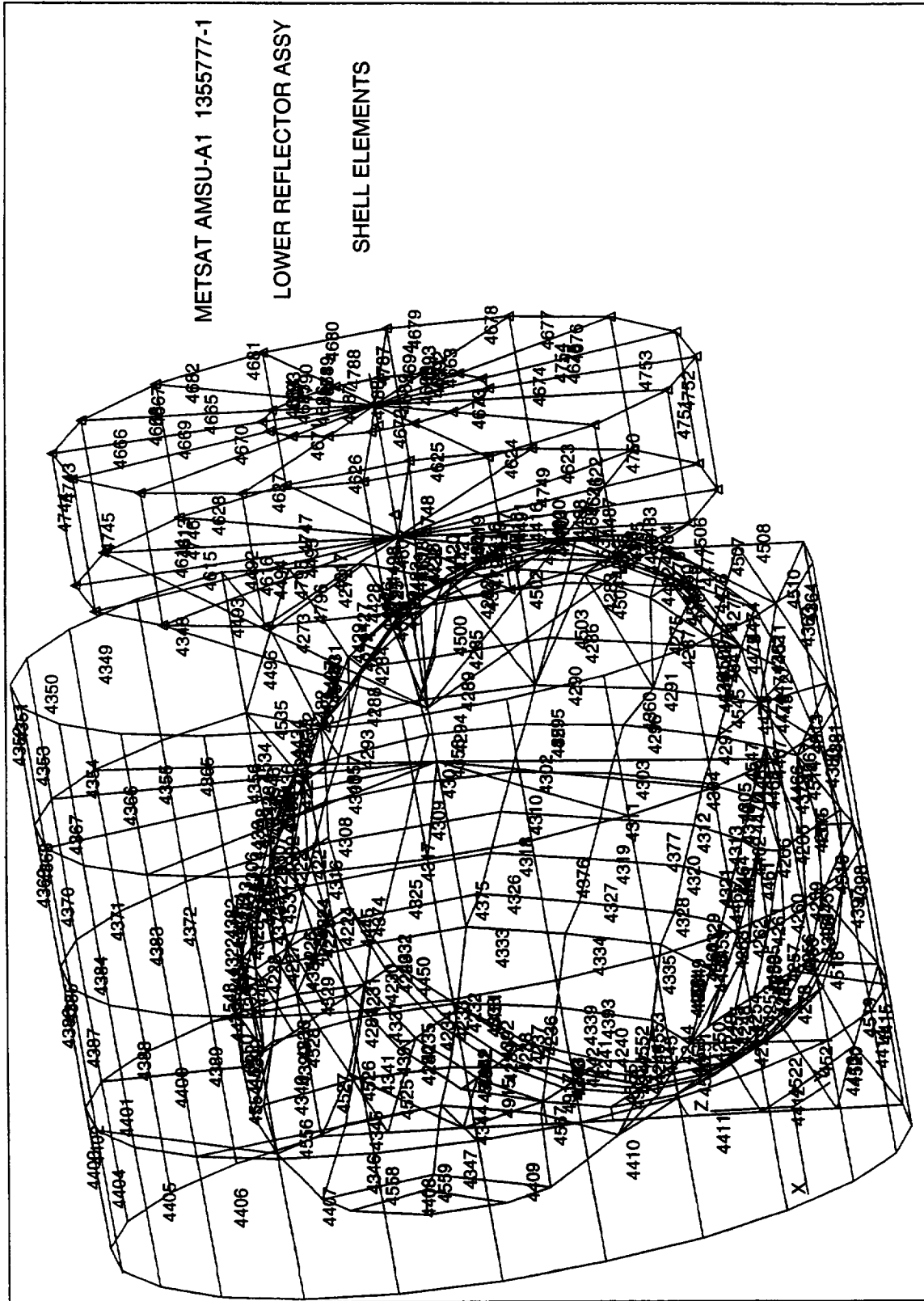

Figure A-107 METSAT AMSU-A1 1355777-1 Lower Reflector Assembly Shell Elements

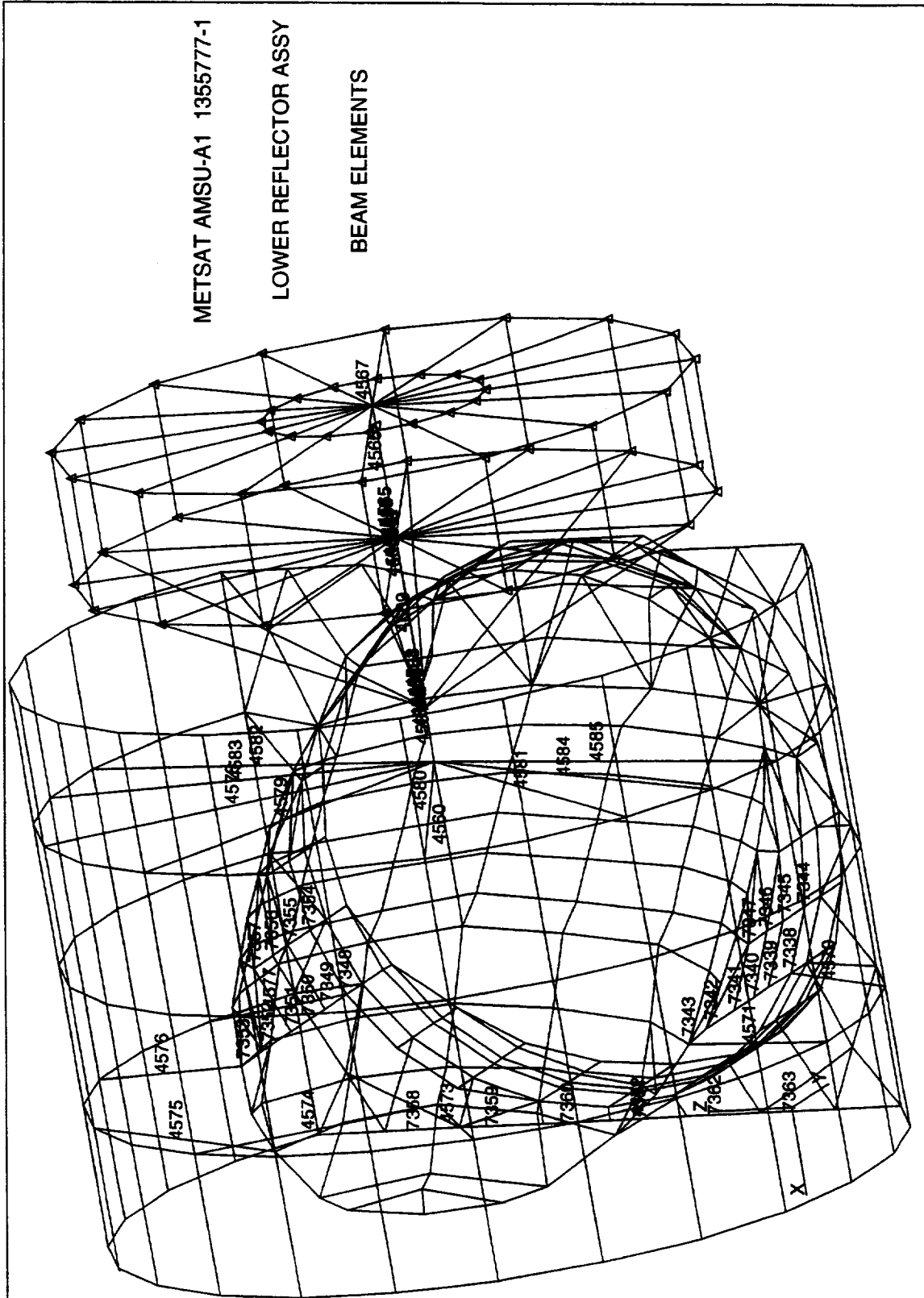

Figure A-108 METSAT AMSU-A1 1355777-1 Lower Reflector Assembly Beam Elements

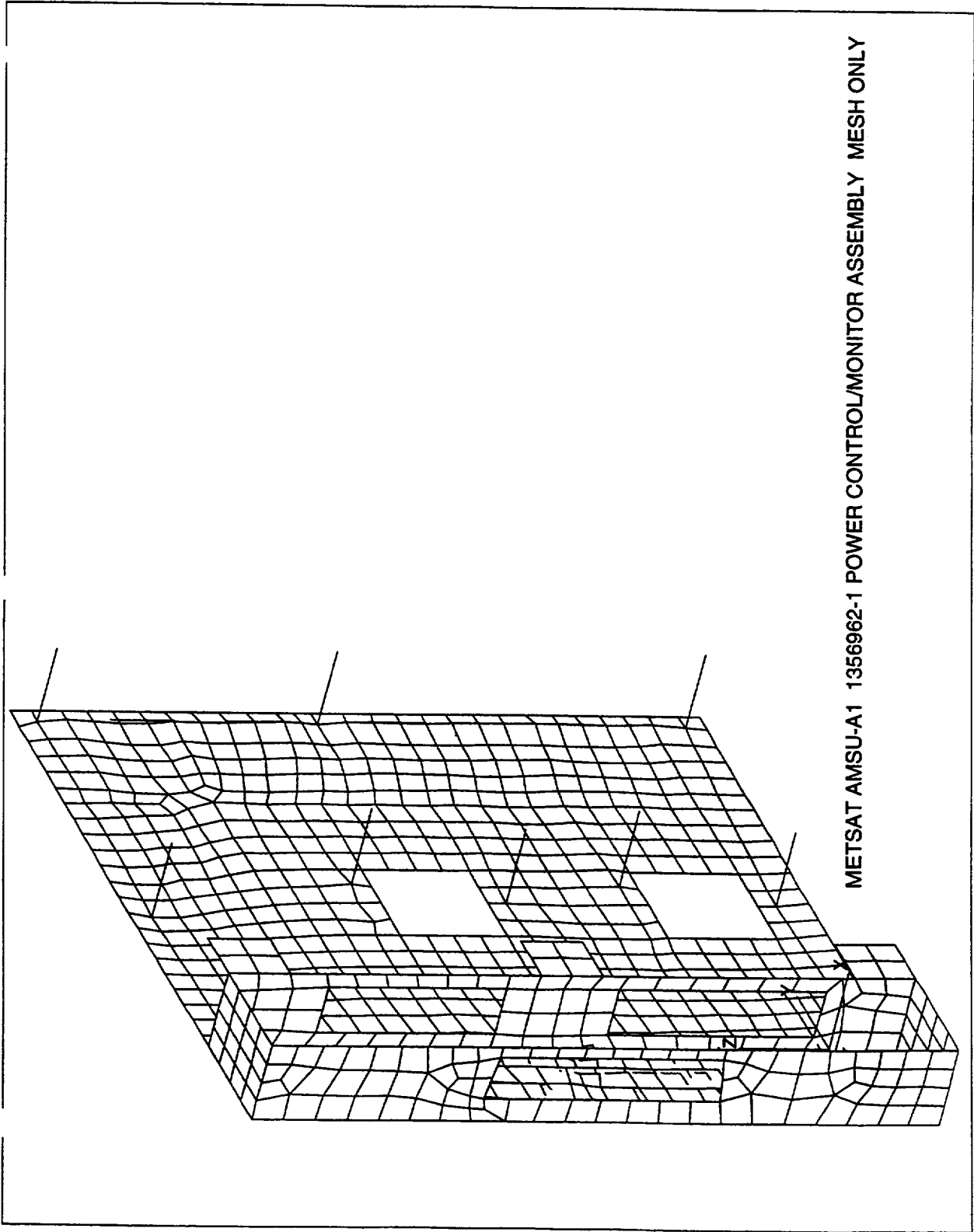

Figure A-110 METSAT AMSU-A1 1356962-1 Power Control/Monitor Assembly Mesh Only

METSAT AMSU-A1 POWER CONTROL/MONITOR - PCB ONLY - MESH ONLY

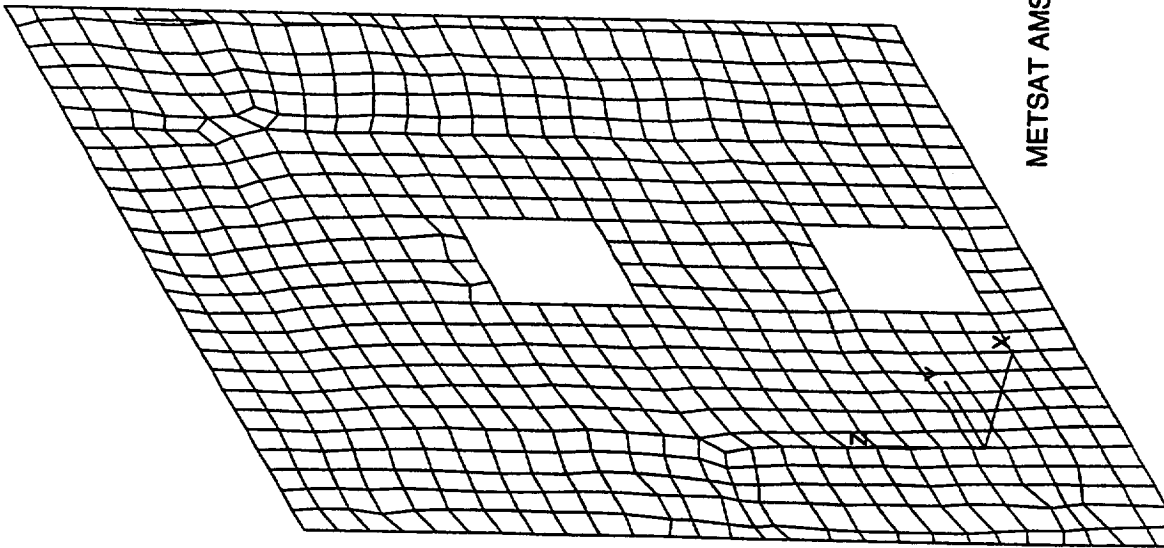

Figure A-111 METSAT AMSU-A1 Power Control/Monitor - PCB Only - Mesh Only

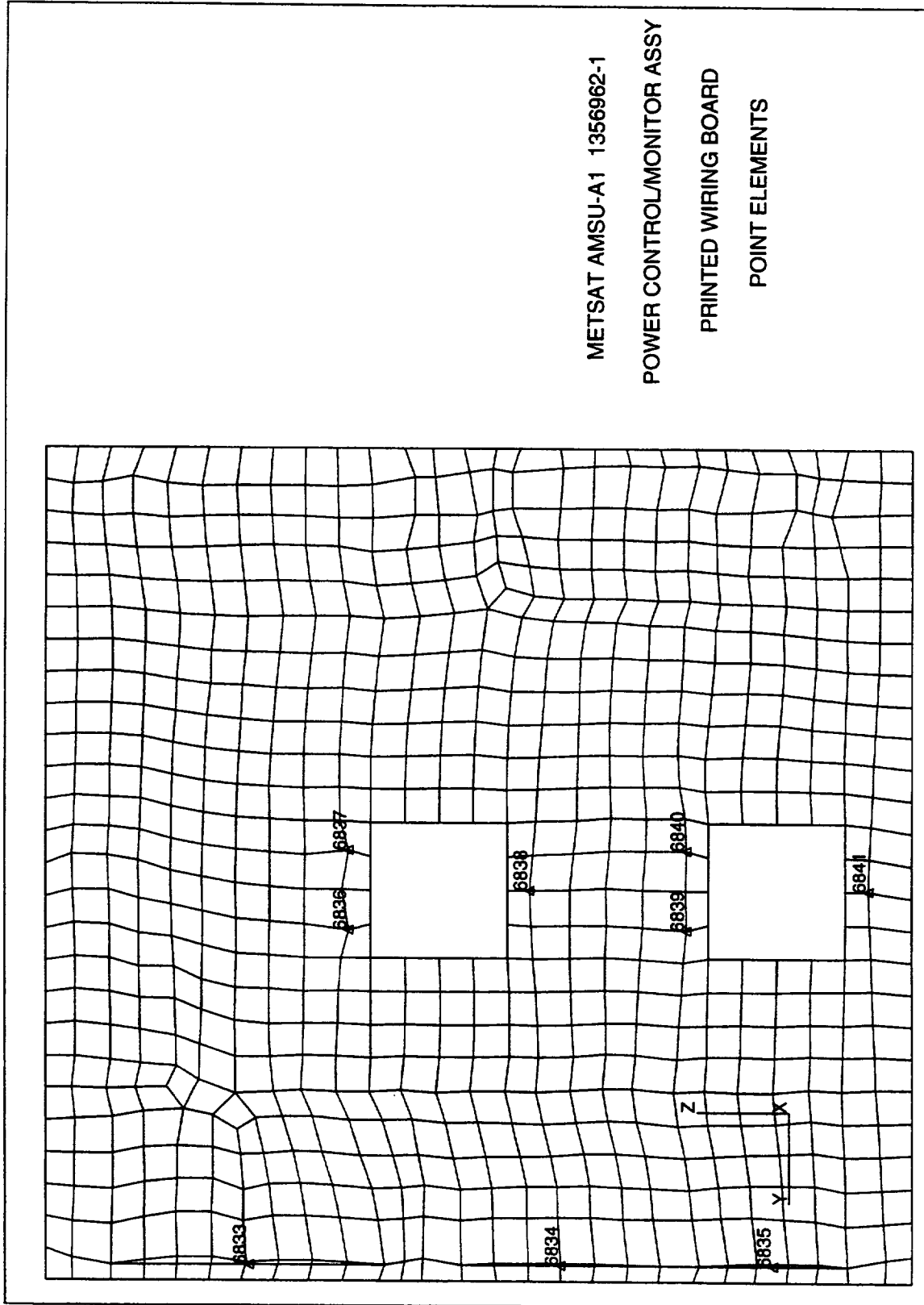

Figure A-114 METSAT AMSU-A1 1356962-1 Power Control/Monitor Assembly Printed Wiring Board Point Elements

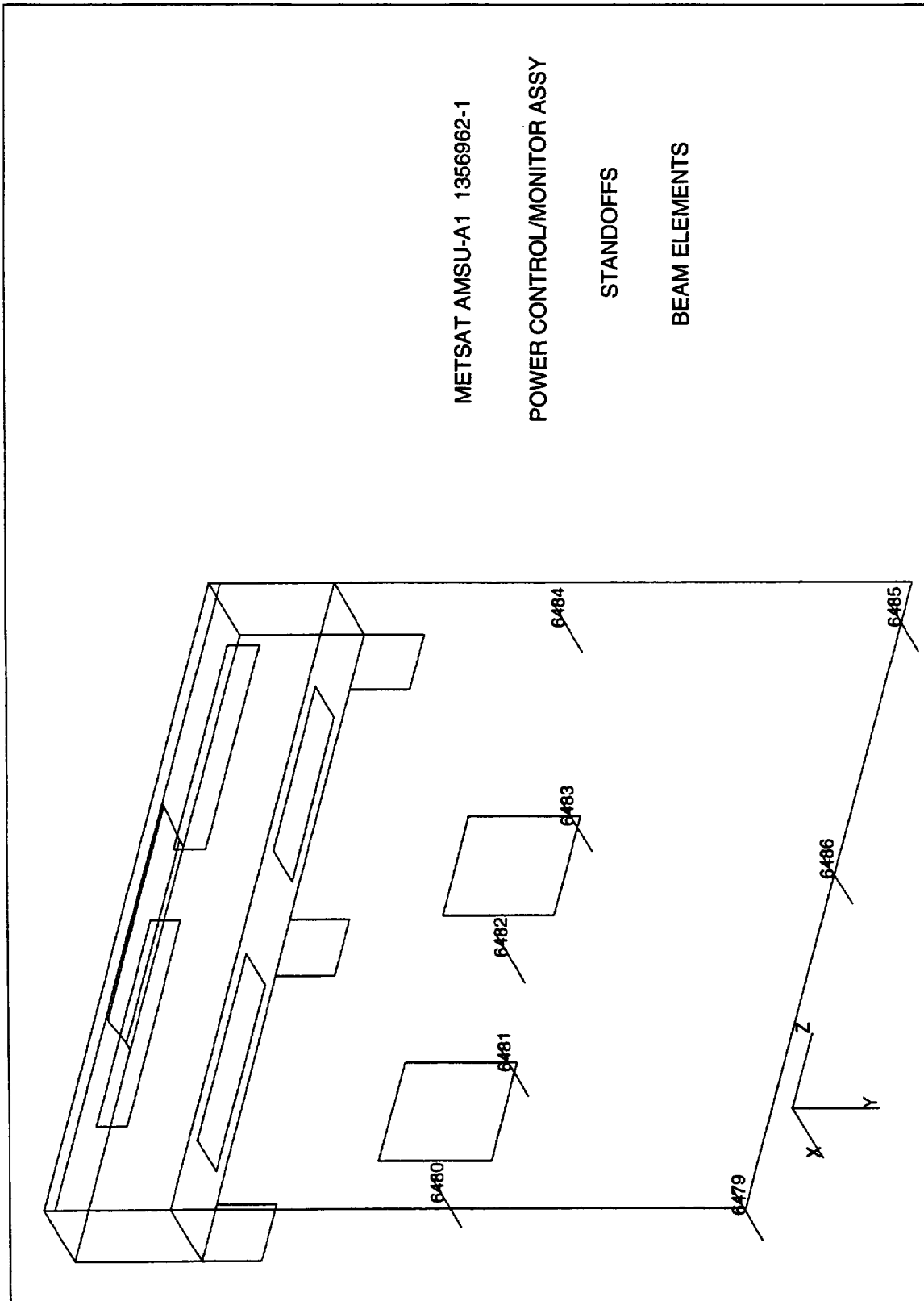

Figure A-115 METSAT AMSU-A1 1356962-1 Power Control/Monitor Assembly Standoffs Beam Elements

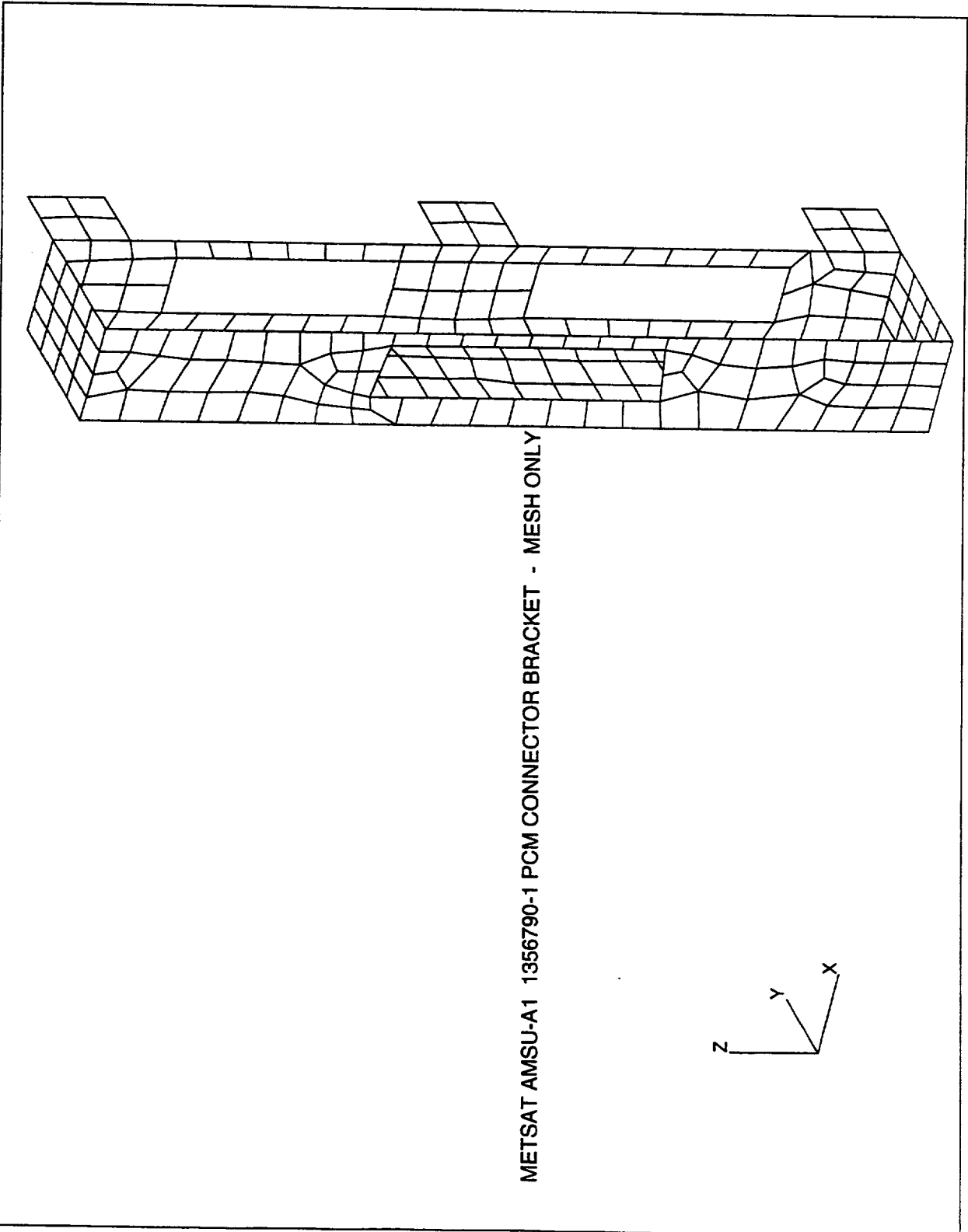

Figure A-116 METSAT AMSU-A1 1356790-1 PCM Connector Bracket Mesh Only

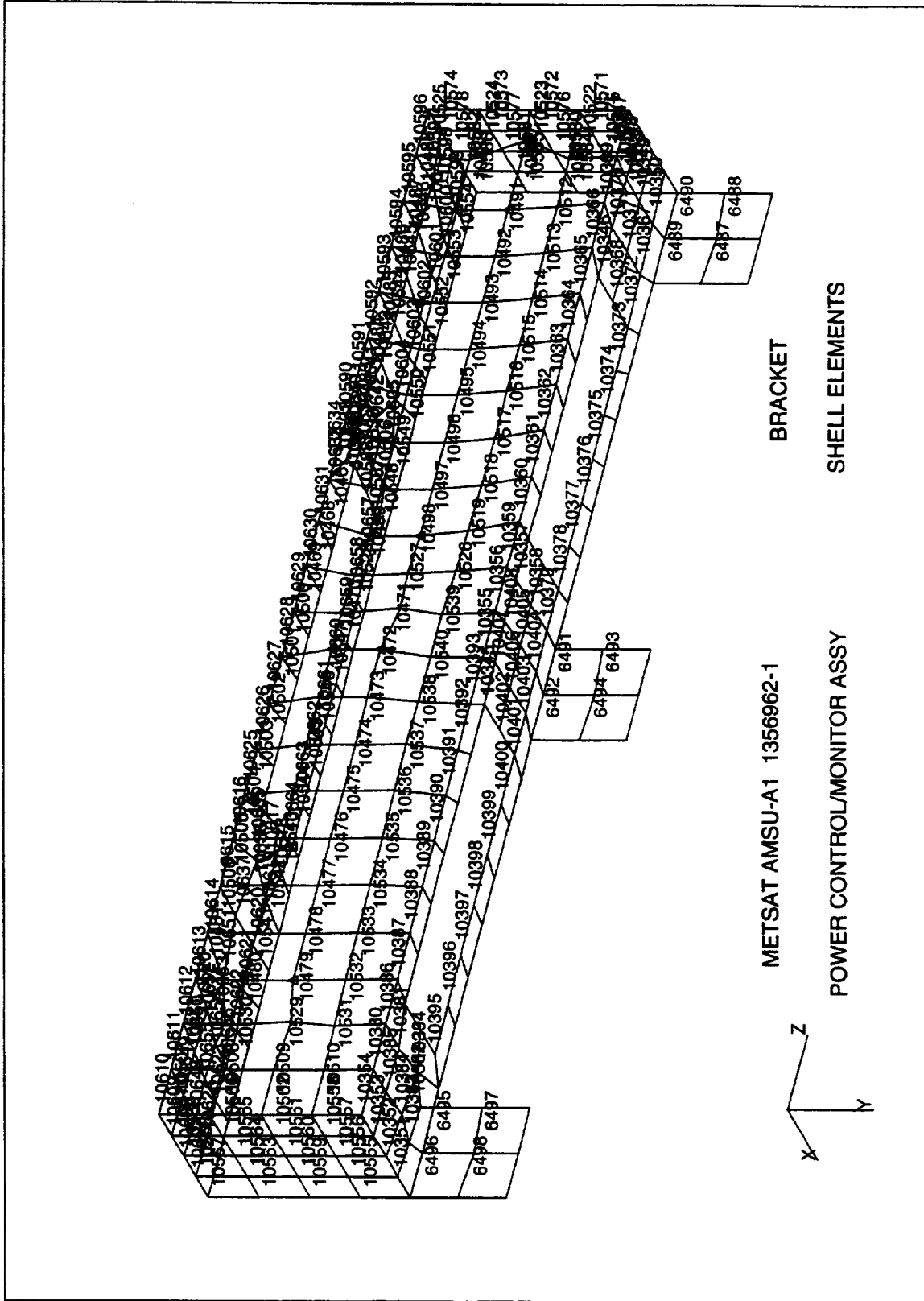

Figure A-118 METSAT AMSU-A1 1356962-1 Bracket Power Control/Monitor Assembly Shell Elements

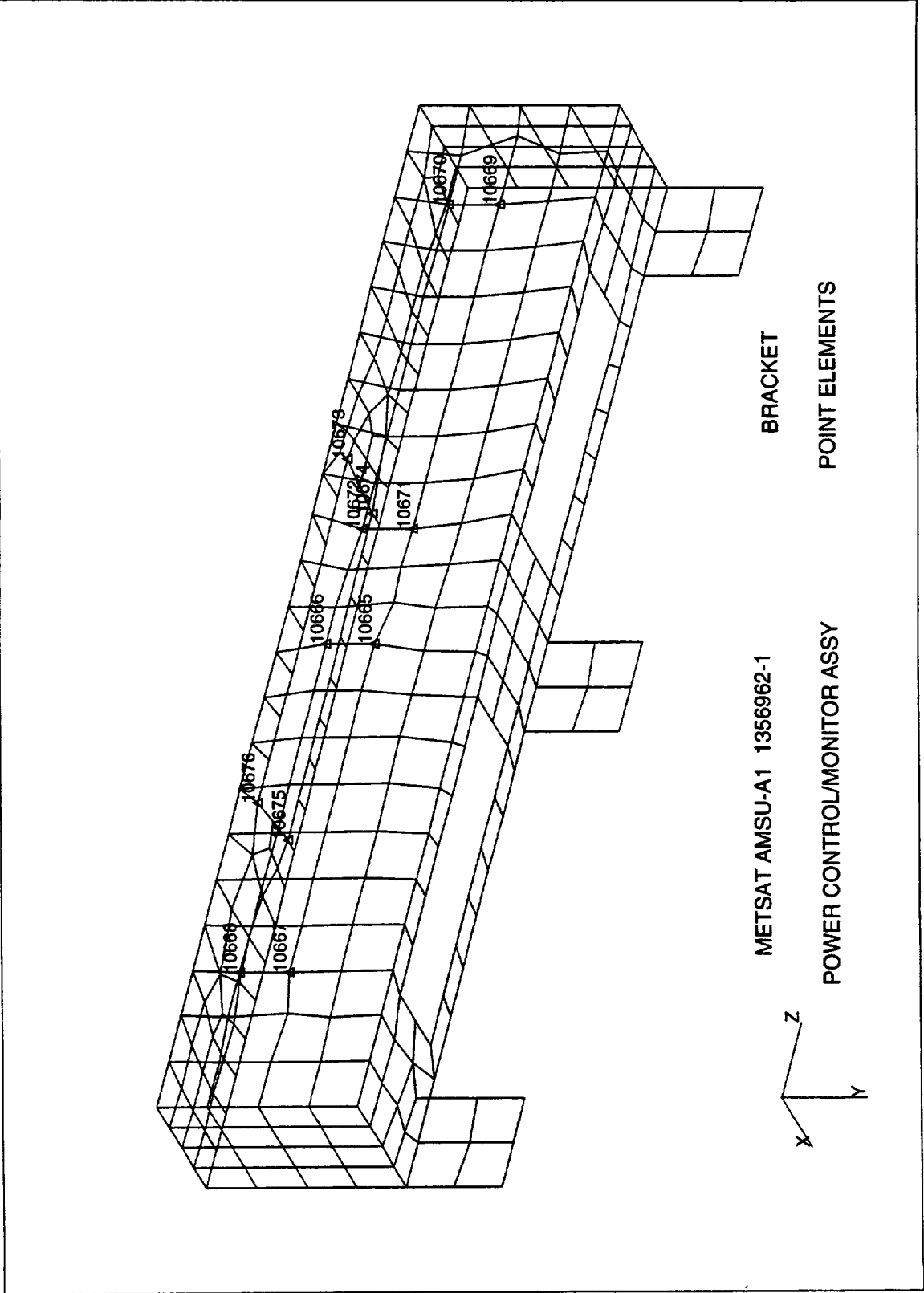

Figure A-119 METSAT AMSU-A1 1356962-1 Bracket Power Control/Monitor Assembly Point Elements

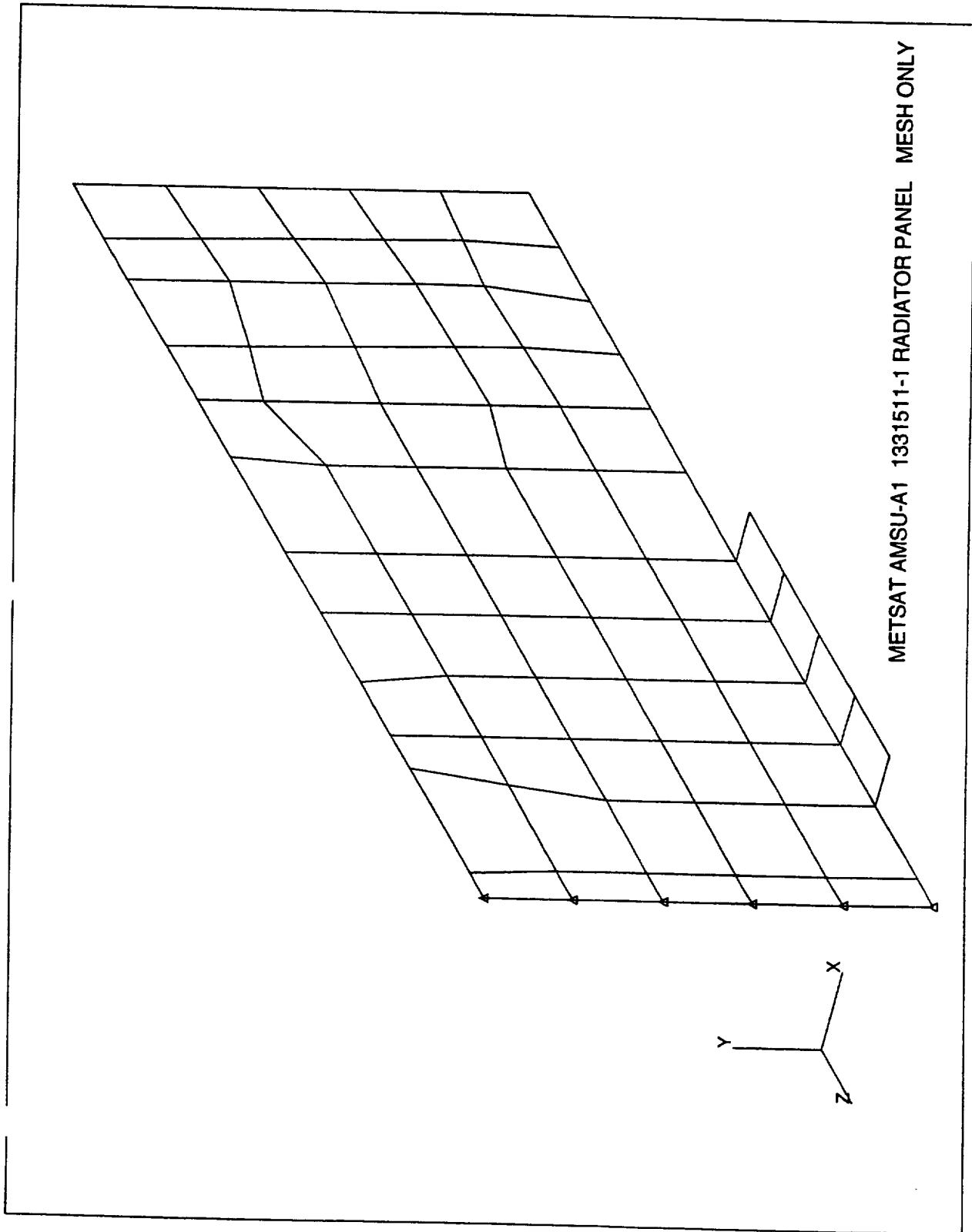

Figure A-120 METSAT AMSU-A1 1331511-1 Radiator Panel Mesh Only

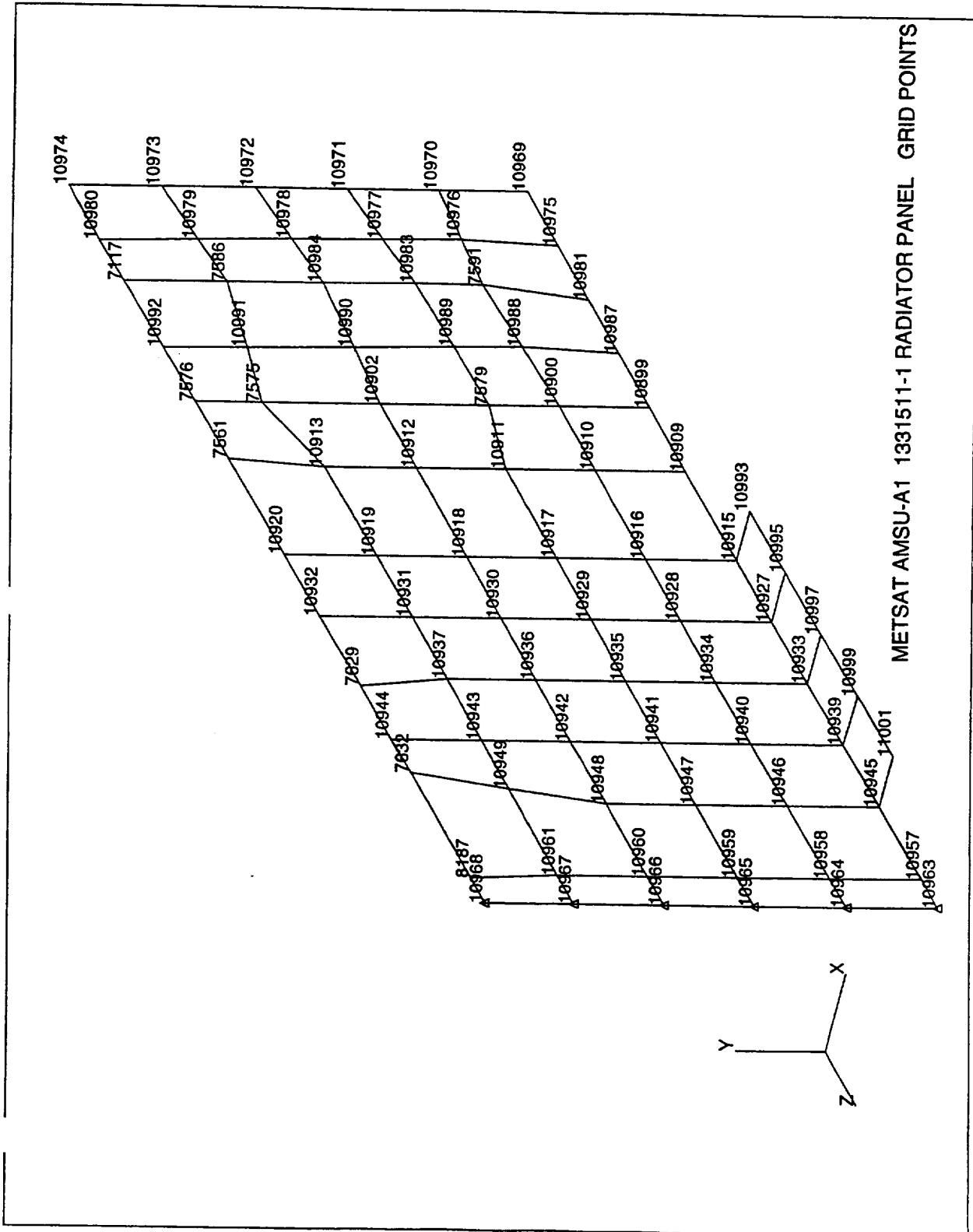

Figure A-121 METSAT AMSU-A1 1331511-1 Radiator Panel Grid Points

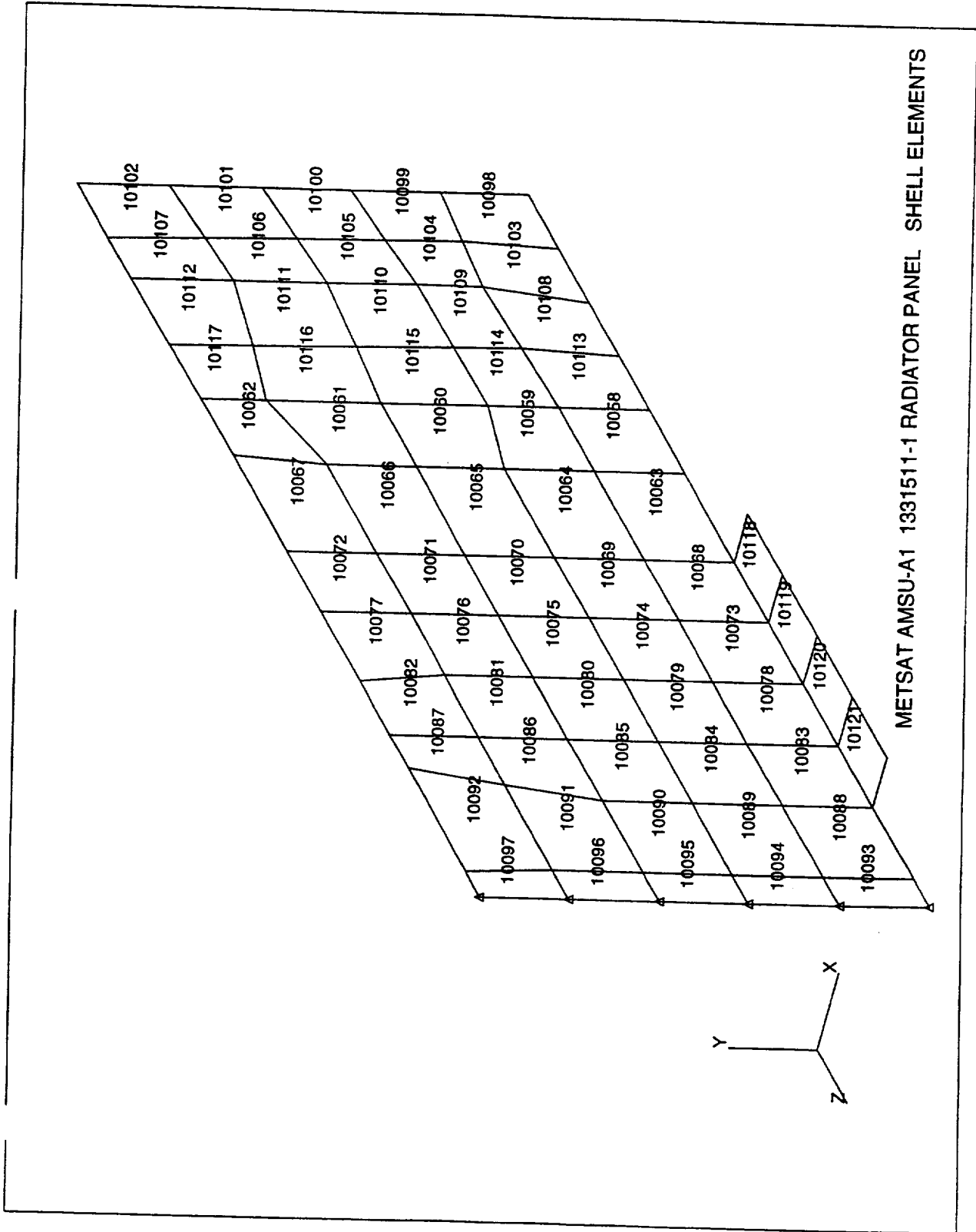

Figure A-122 METSAT AMSU-A1 1331511-1 Radiator Panel Shell Elements

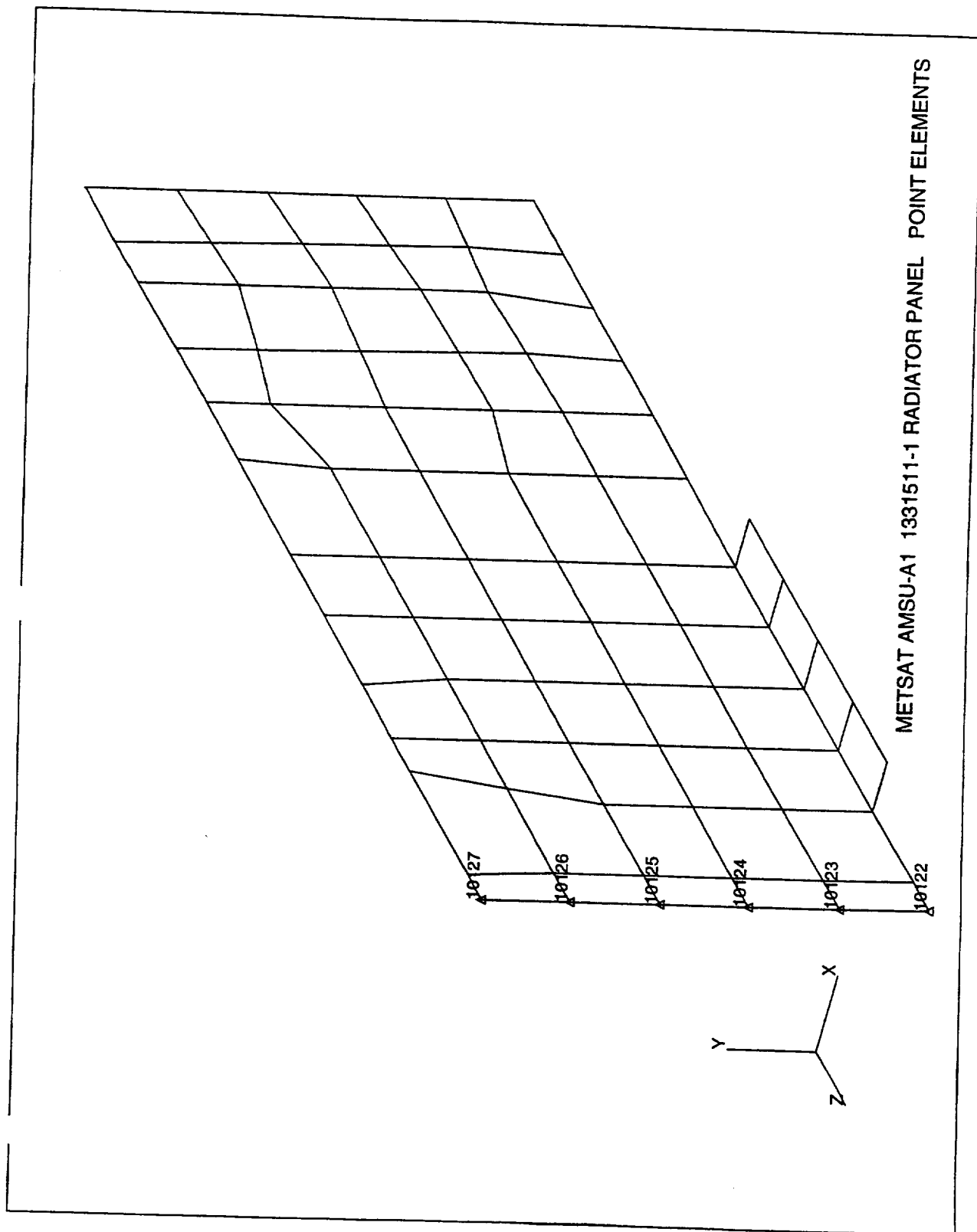

Figure A-123 METSAT AMSU-A1 1331511-1 Radiator Panel Point Elements

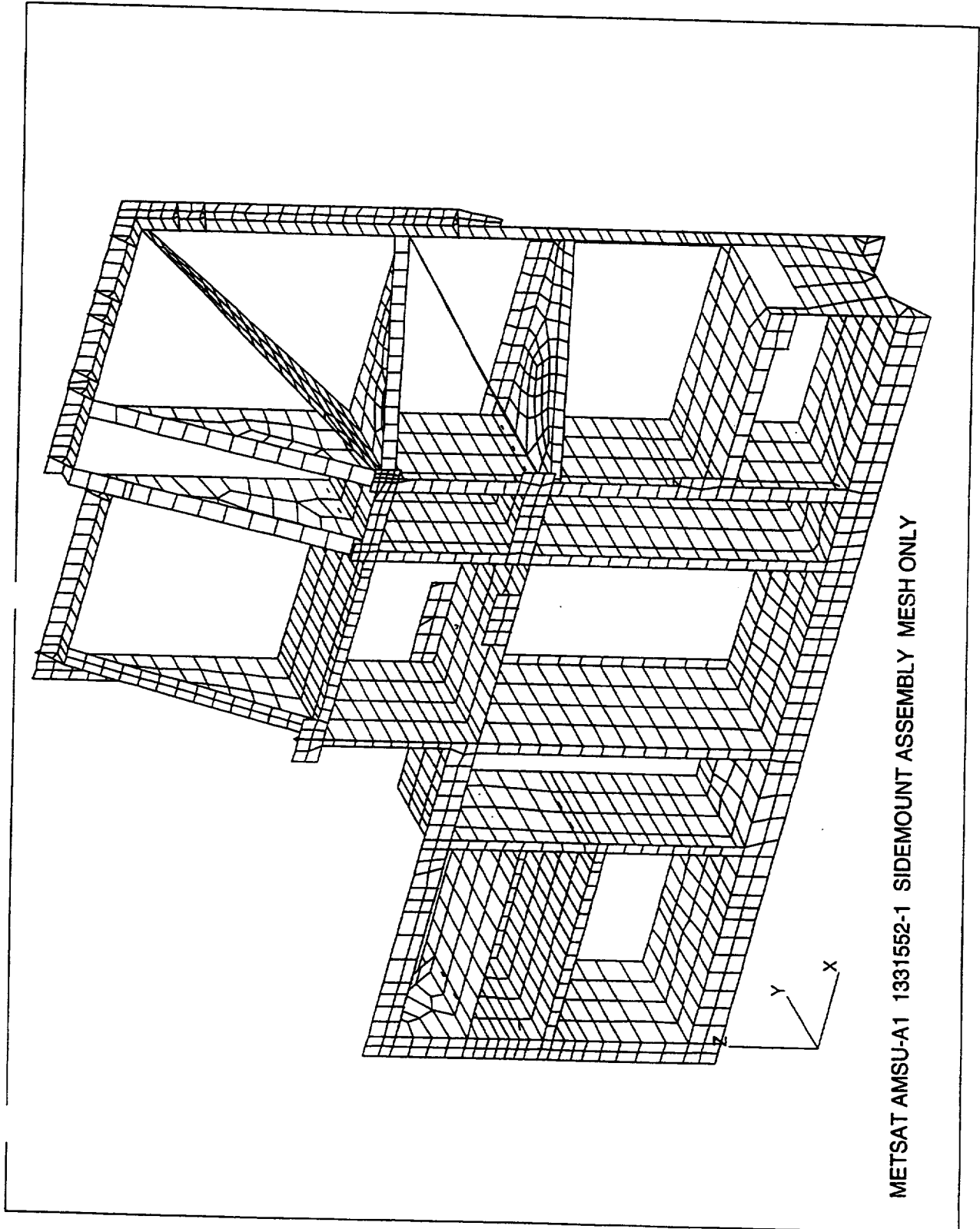

Figure A-124 METSAT AMSU-A1 1331552-1 Sidemount Assembly Mesh Only

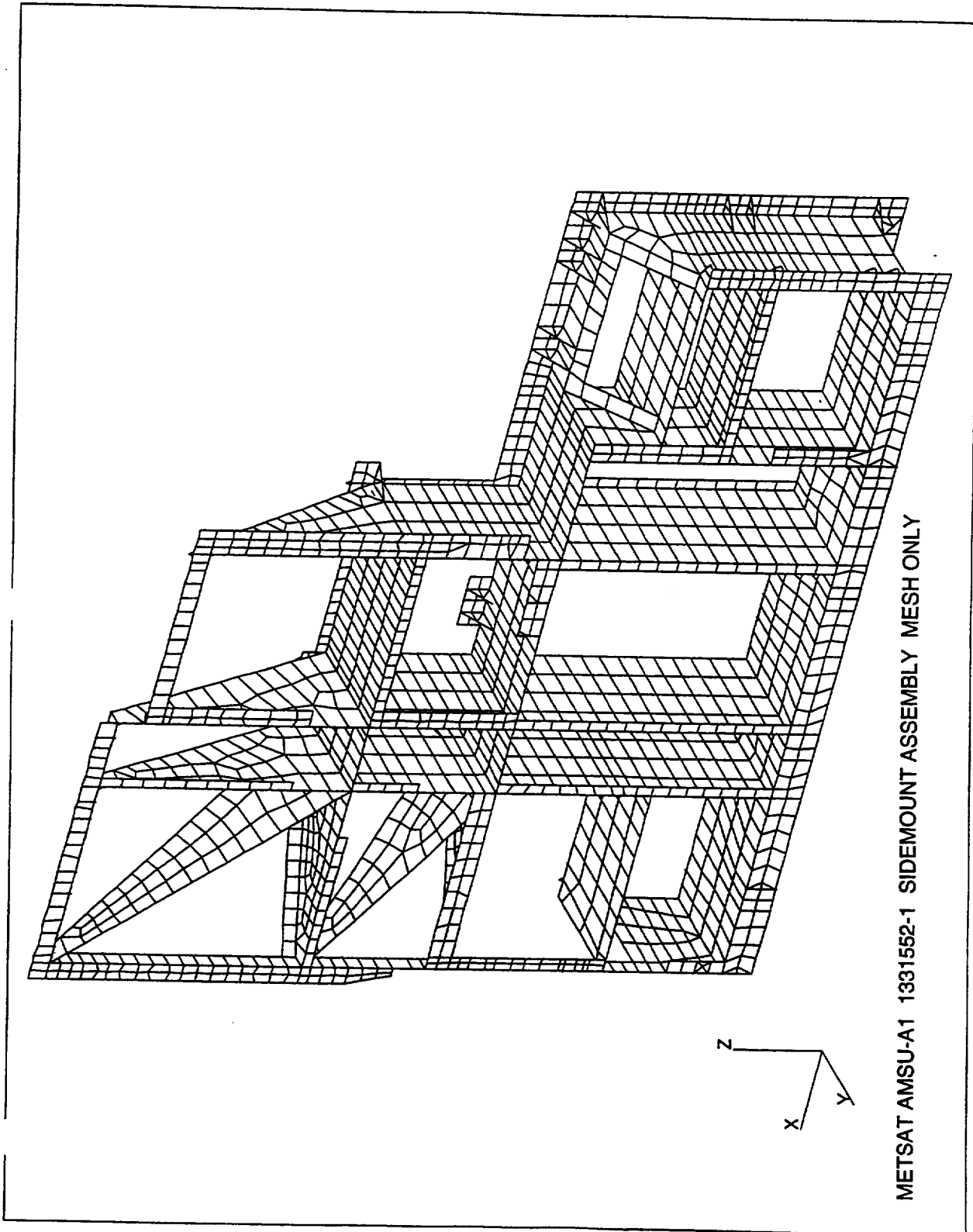

Figure A-125 METSAT AMSU-A1 1331552-1 Sidemount Assembly Mesh Only

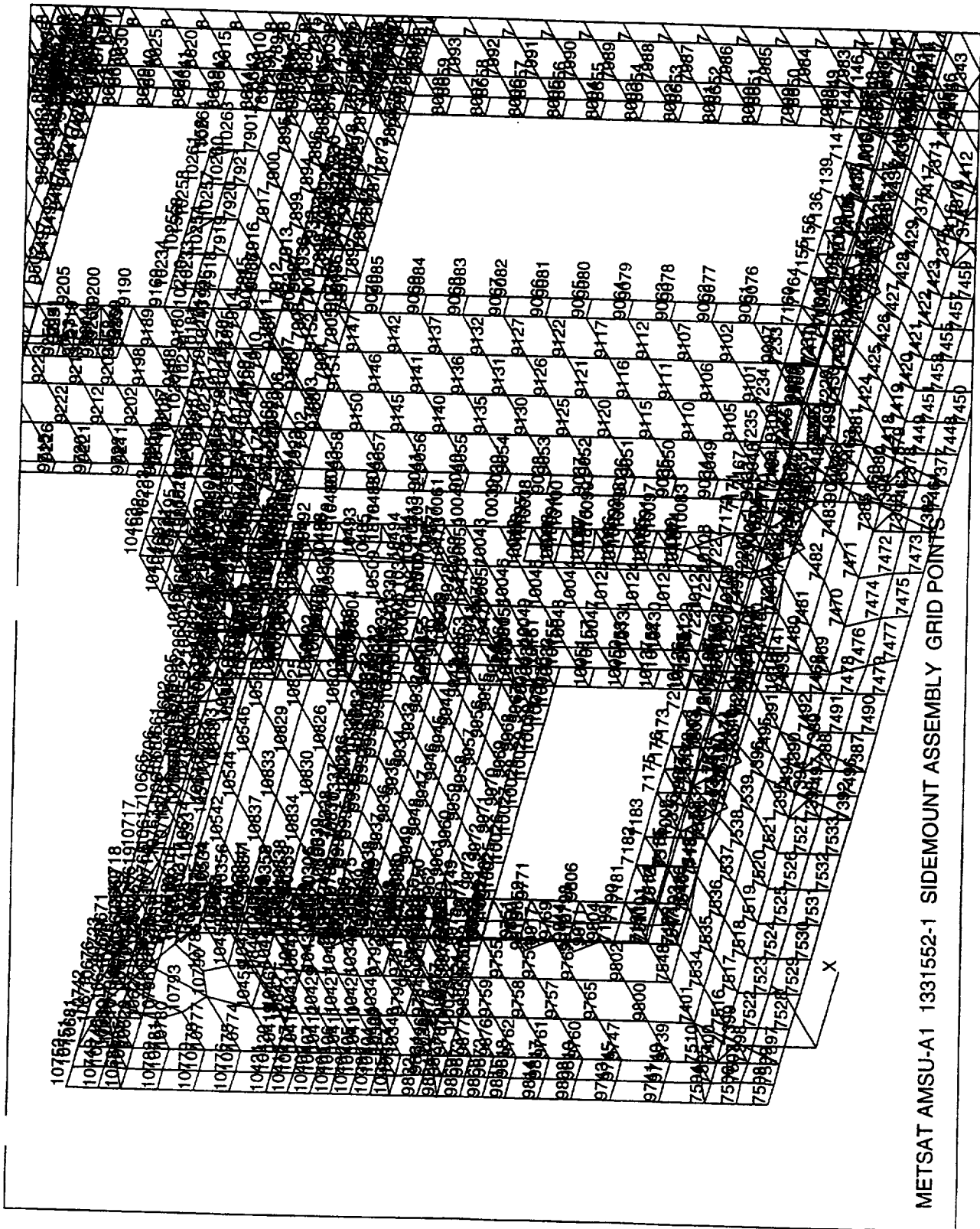

Figure A-126 METSAT AMSU-A1 1331552-1 Sidemount Assembly Grid Points

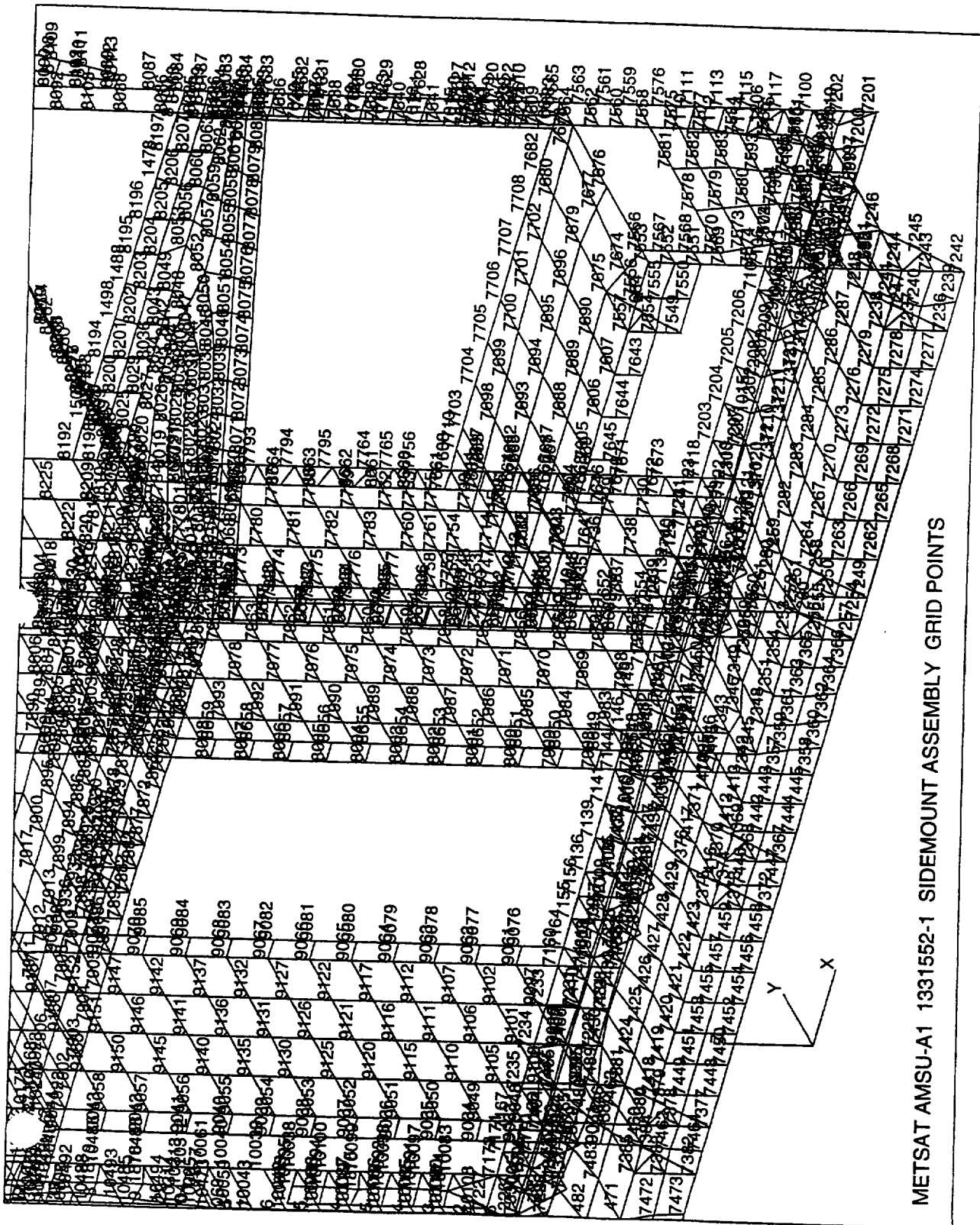

Figure A-127 METSAT AMSU-A1 1331552-1 Sidemount Assembly Grid Points

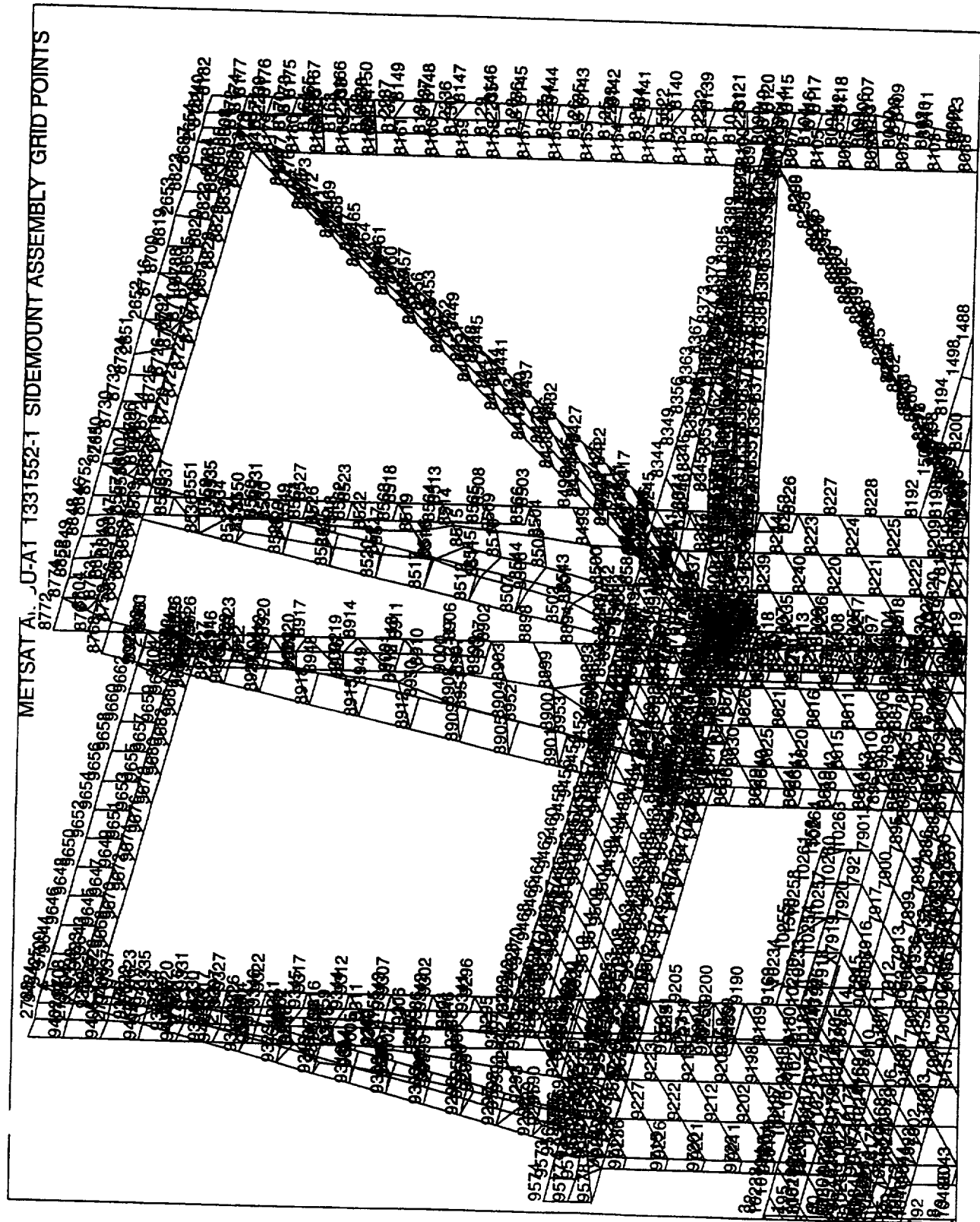

Figure A-128 METSAT AMSU-A1 1331552-1 Sidemount Assembly Grid Points

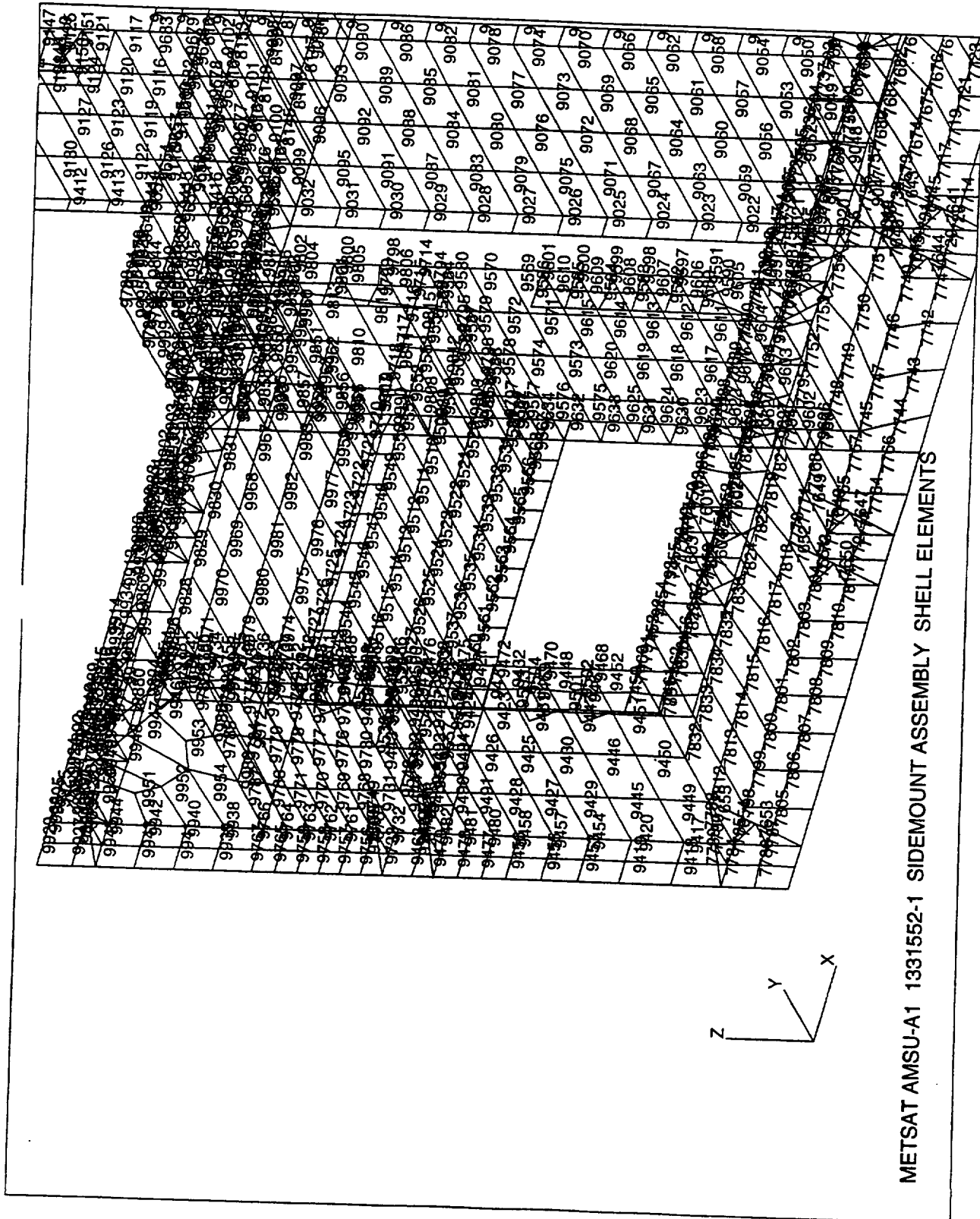

Figure A-129 METSAT AMSU-A1 1331552-1 Sidemount Assembly Shell Elements

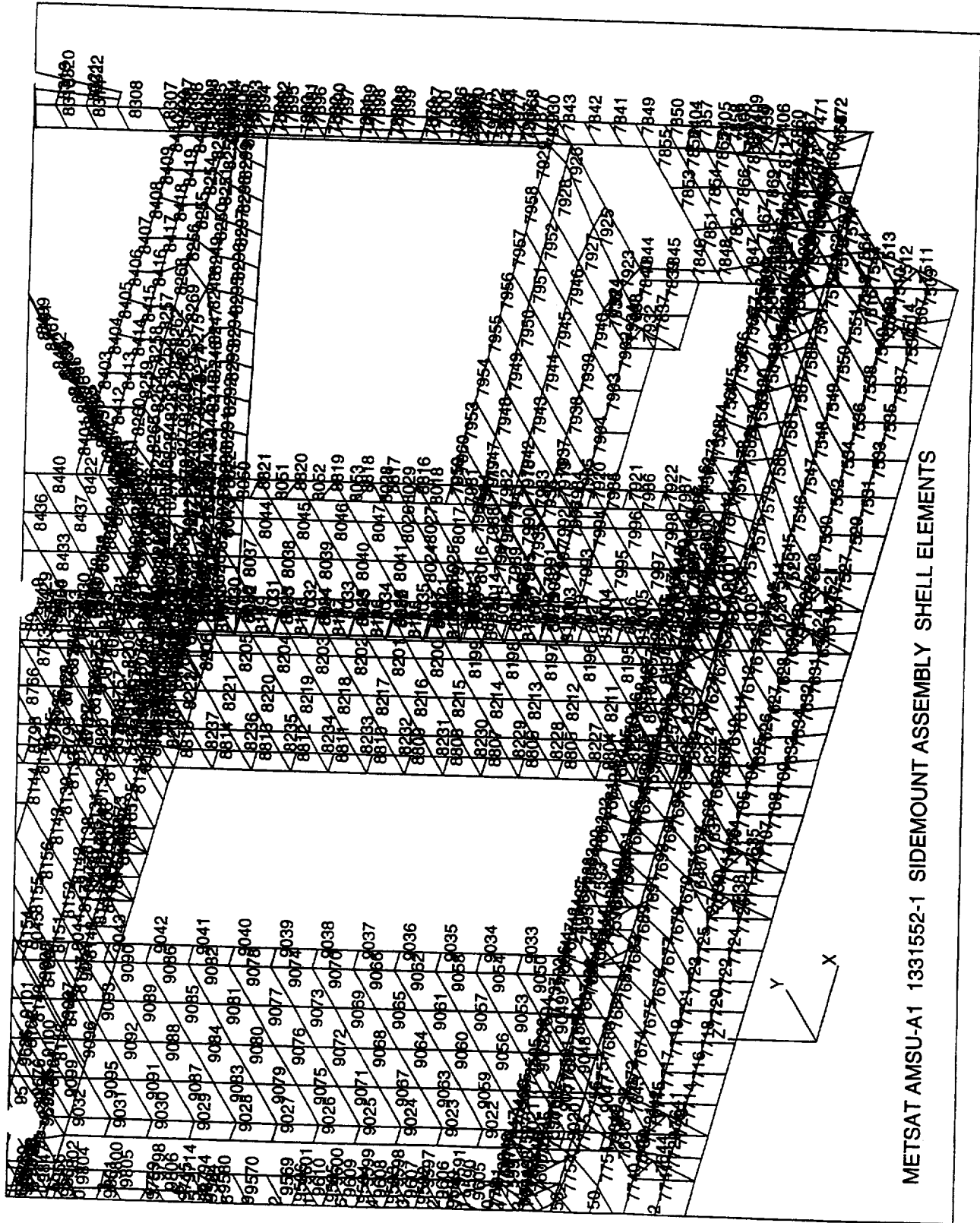

Figure A-130 METSAT AMSU-A1 1331552-1 Sidemount Assembly Shell Elements

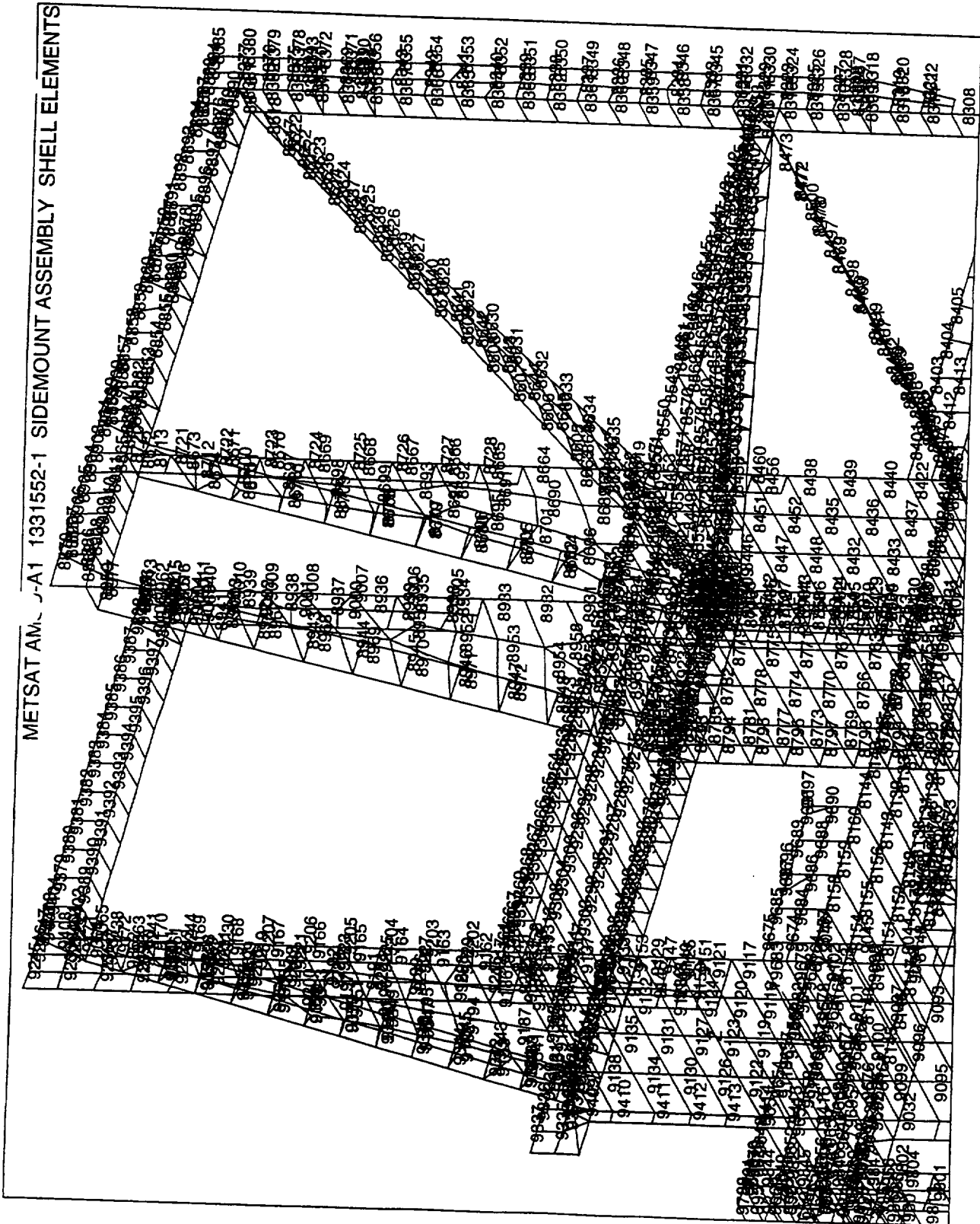

Figure A-131 METSAT AMSU-A1 1331552-1 Sidemount Assembly Shell Elements

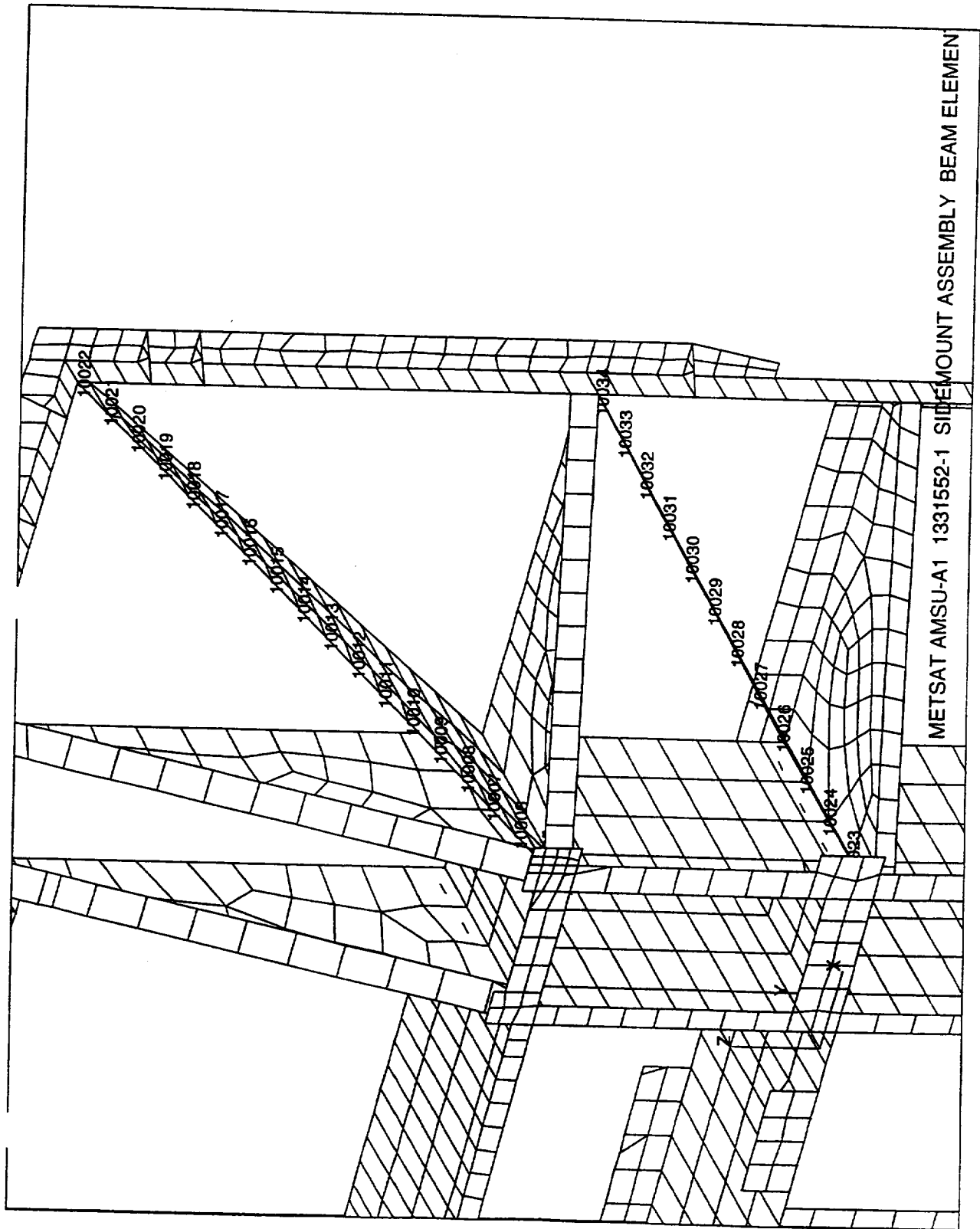

Figure A-132 METSAT AMSU-A1 1331552-1 Sidemount Assembly Beam Element

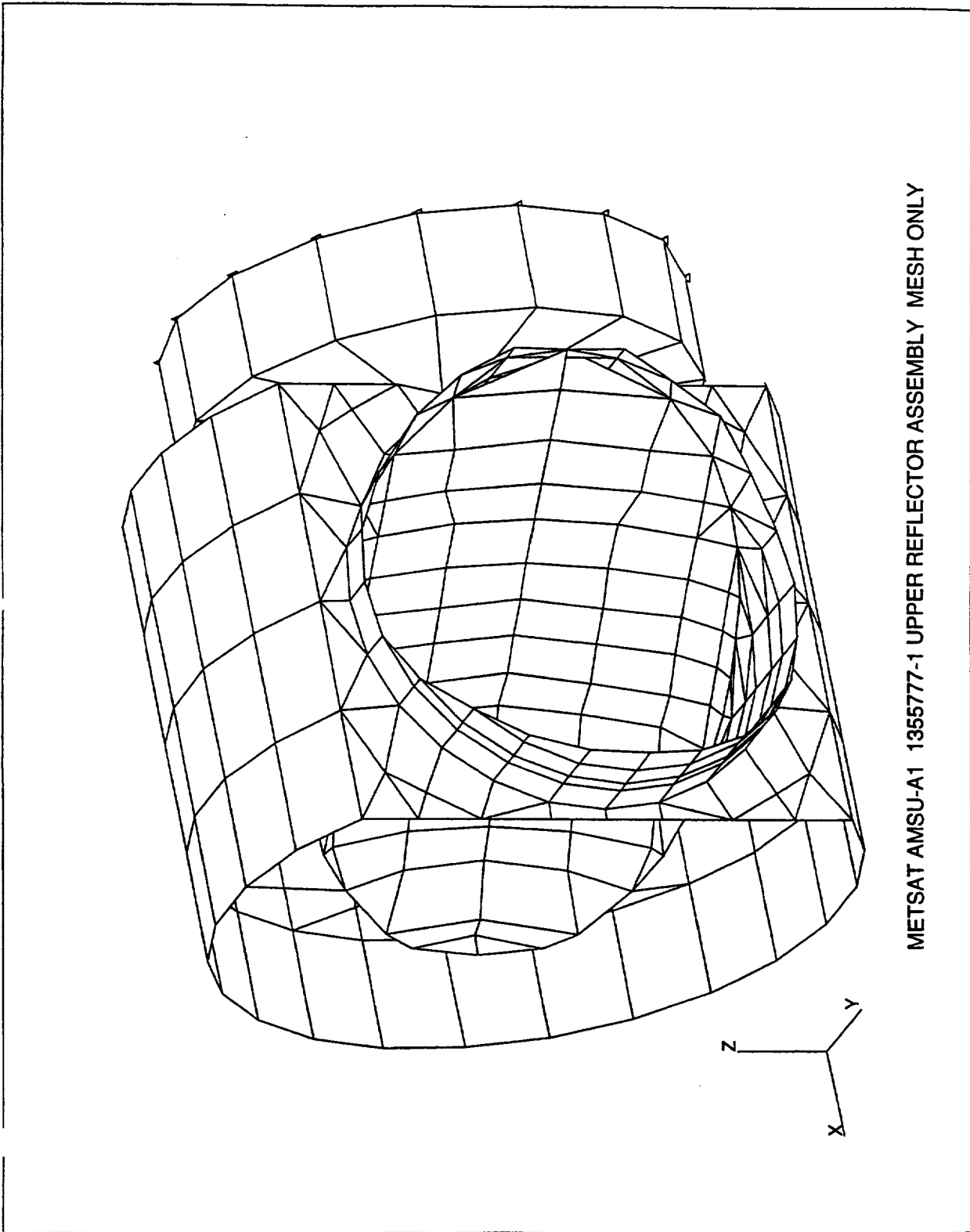

Figure A-133 METSAT AMSU-A1 1355777-1 Upper Reflector Assembly Grid Points

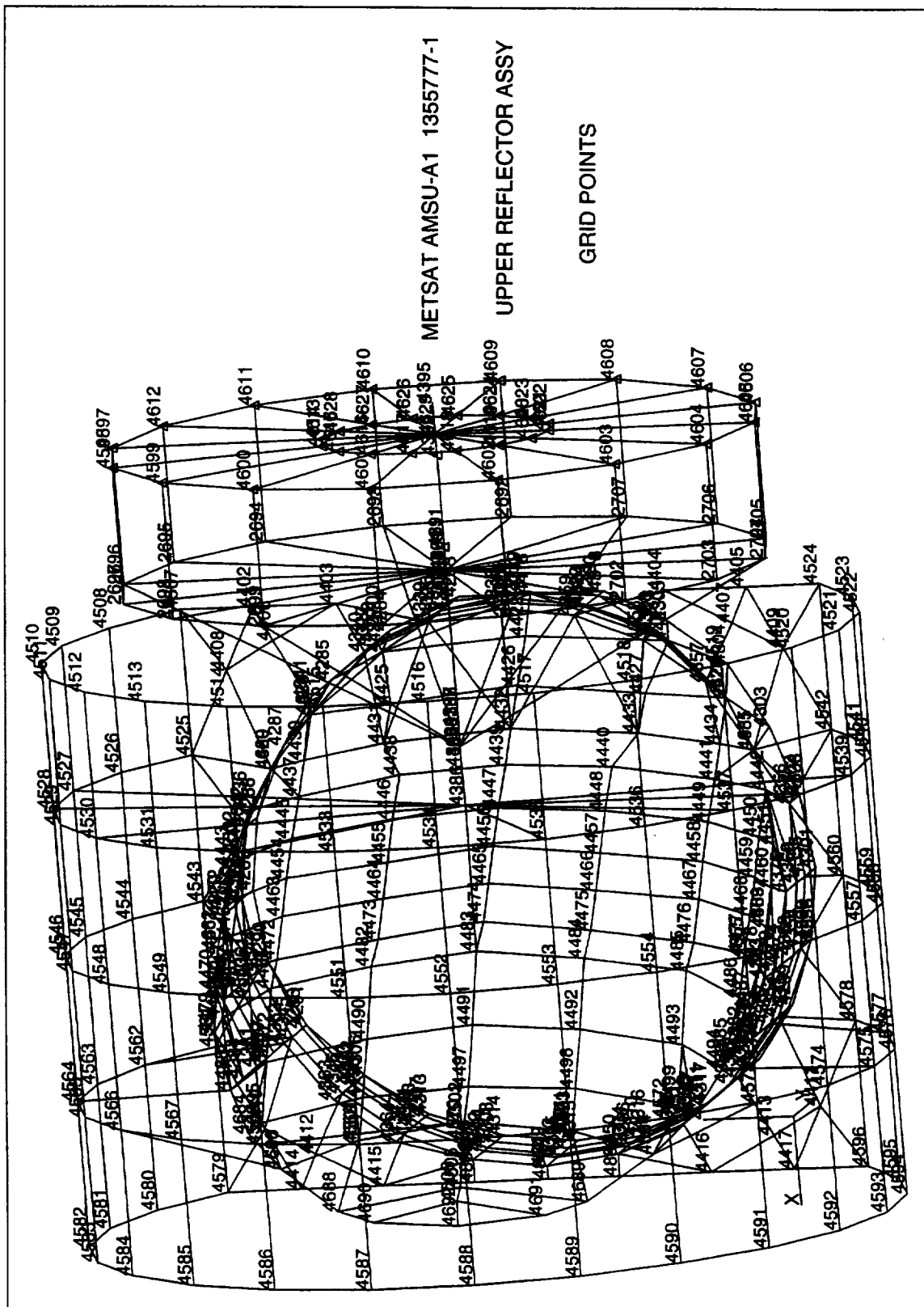

Figure A-134 METSAT AMSU-A1 1355777-1 Upper Reflector Assembly Grid Points

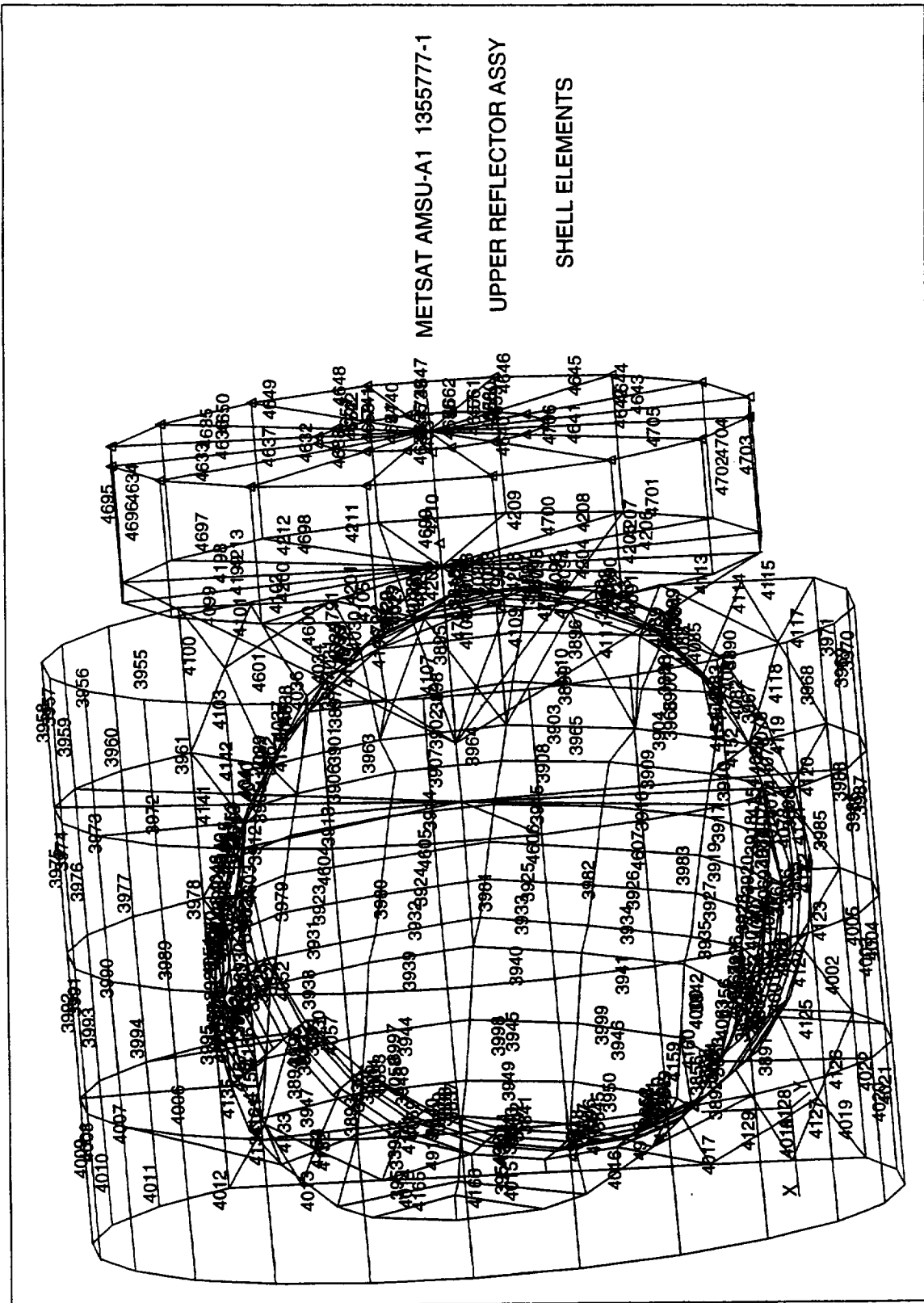

Figure A-135 METSAT AMSU-A1 1355777-1 Upper Reflector Assembly Shell Elements

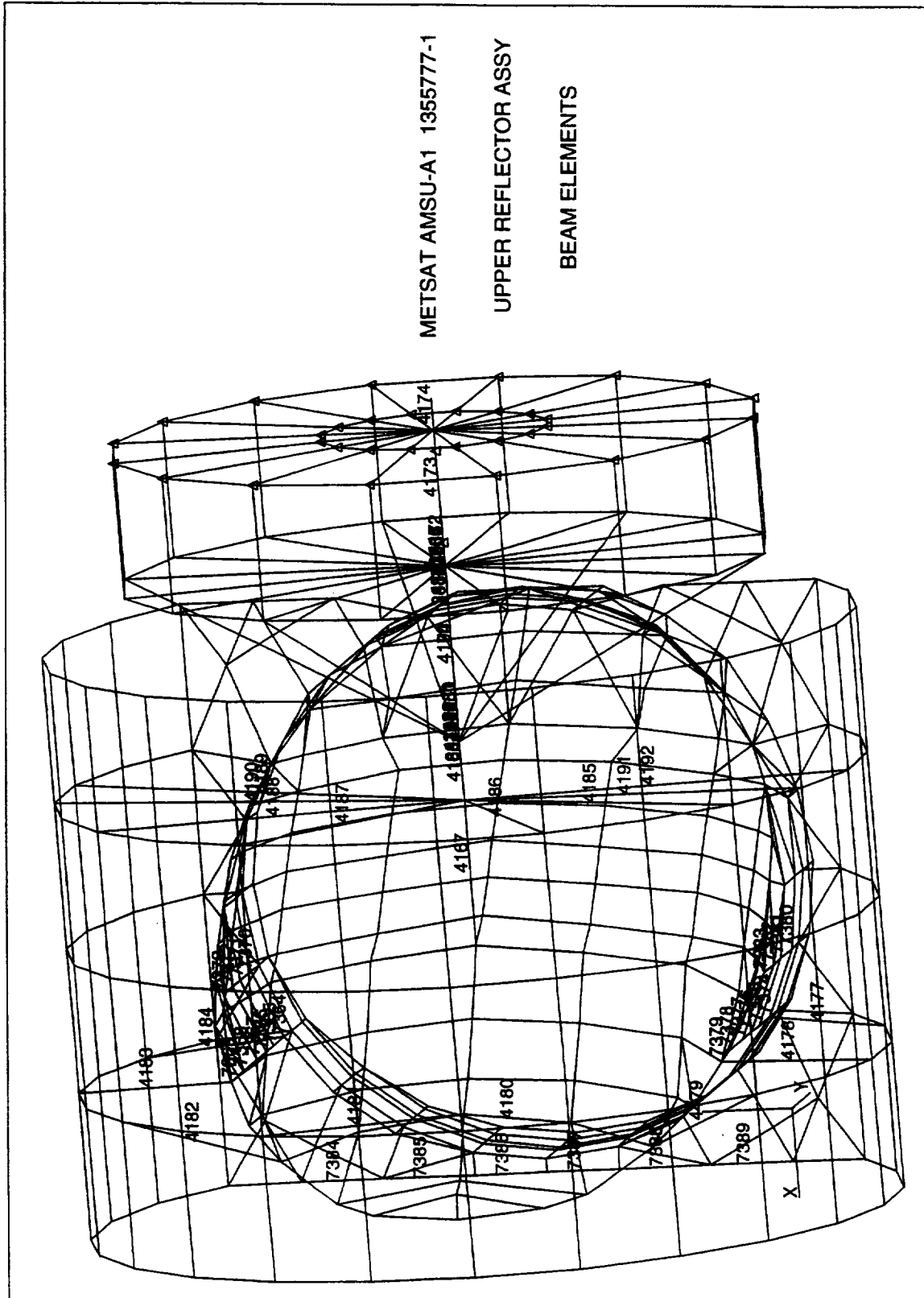

Figure A-136 METSAT AMSU-A1 1355777-1 Upper Reflector Assembly Beam Elements

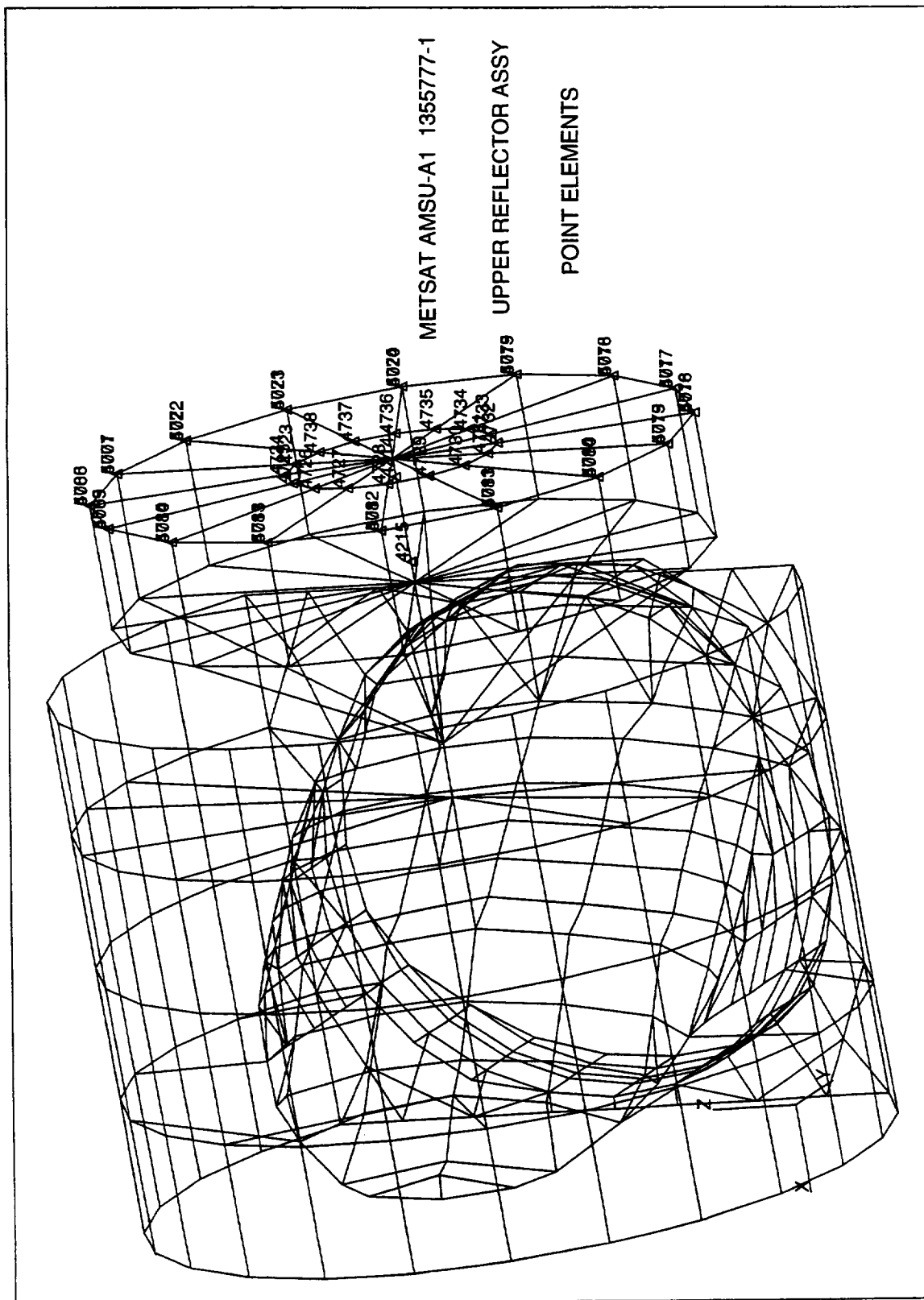



Figure A-137 METSAT AMSU-A1 1355777-1 Upper Reflector Assembly Point Elements

 NASA National Aeronautics and Space Administration		Report Documentation Page	
1. Report No. ---	2. Government Accession No. ---	3. Recipient's Catalog No. ---	
4. Title and Subtitle METSAT Advanced Microwave Sounding Unit-A (AMSU-A), Structural Mathematical Model, A1		5. Report Date 1 April 1996	6. Performing Organization Code ---
		7. Author(s) R.J. Heffner	8. Performing Organization Report No. 10738
9. Performing Organization Name and Address Aerojet 1100 W. Hollyvale Azusa, CA 91702		10. Work Unit No. ---	11. Contract or Grant No. NAS 5-32314
		12. Sponsoring Agency Name and Address NASA Goddard Space Flight Center Greenbelt, Maryland 20771	
13. Type of Report and Period Covered Final		14. Sponsoring Agency Code ---	
15. Supplementary Notes ---			
16. ABSTRACT (Maximum 200 words) This is the METSAT Structural Mathematical Model for the Advanced Microwave Sounding Unit-A (AMSU-A), A1.			
17. Key Words (Suggested by Author(s)) EOS Microwave System		18. Distribution Statement Unclassified — Unlimited	
19. Security Classif. (of this report) Unclassified	20. Security Classif. (of this page) Unclassified	21. No. of pages 152	22. Price ---

NASA FORM 1626 OCT 86

PREPARATION OF THE REPORT DOCUMENTATION PAGE

The last page of a report facing the third cover is the Report Documentation Page, RDP. Information presented on this page is used in announcing and cataloging reports as well as preparing the cover and title page. Thus, it is important that the information be correct. Instructions for filling in each block of the form are as follows:

Block 1. Report No. NASA report series number, if preassigned.

Block 2. Government Accession No. Leave blank.

Block 3. Recipient's Catalog No. Reserved for use by each report recipient.

Block 4. Title and Subtitle. Typed in caps and lower case with dash or period separating subtitle from title.

Block 5. Report Date. Approximate month and year the report will be published.

Block 6. Performing Organization Code. Leave blank.

Block 7. Authors. Provide full names exactly as they are to appear on the title page. If applicable, the word editor should follow a name.

Block 8. Performing Organization Report No. NASA installation report control number and, if desired, the non-NASA performing organization report control number.

Block 9. Performing Organization Name and Address. Provide affiliation (NASA program office, NASA installation, or contractor name) of authors.

Block 10. Work Unit No. Provide Research and Technology Objectives and Plants (RTOP) number.

Block 11. Contract or Grant No. Provide when applicable.

Block 12. Sponsoring Agency Name and Address. National Aeronautics and Space Administration, Washington, D.C. 20546-0001. If contractor report, add NASA installation or HQ program office.

Block 13. Type of Report and Period Covered. NASA formal report series; for Contractor Report also list type (interim, final) and period covered when applicable.

Block 14. Sponsoring Agency Code. Leave blank.

Block 15. Supplementary Notes. Information not included

elsewhere: affiliation of authors if additional space is required for Block 9, notice of work sponsored by another agency, monitor of contract, information about supplements (file, data tapes, etc.) meeting site and date for presented papers, journal to which an article has been submitted, note of a report made from a thesis, appendix by author other than shown in Block 7.

Block 16. Abstract. The abstract should be informative rather than descriptive and should state the objectives of the investigation, the methods employed (e.g., simulation, experiment, or remote sensing), the results obtained, and the conclusions reached.

Block 17. Key Words. Identifying words or phrases to be used in cataloging the report.

Block 18. Distribution Statement. Indicate whether report is available to public or not. If not to be controlled, use "Unclassified-Unlimited." If controlled availability is required, list the category approved on the Document Availability Authorization Form (see NHB 2200.2, Form FF427). Also specify subject category (see "Table of Contents" in a current issue of STAR) in which report is to be distributed.

Block 19. Security Classification (of the report). Self-explanatory.

Block 20. Security Classification (of this page). Self-explanatory.

Block 21. No. of Pages. Count front matter pages beginning with iii, text pages including internal blank pages, and the RDP, but not the title page or the back of the title page.

Block 22. Price Code. If Block 18 shows "Unclassified-Unlimited," provide the NTIS price code (see "NTIS Price Schedules" in a current issue of STAR) and at the bottom of the form add either "For sale by the National Technical Information Service, Springfield, VA 22161-2171" or "For sale by the Superintendent of Documents, U.S. Government Printing Office, Washington, D.C. 20402-0001," whichever is appropriate.

GENERAL INSTRUCTIONS FOR COMPLETING SF 298

The Report Documentation Page (RDP) is used in announcing and cataloging reports. It is important that this information be consistent with the rest of the report, particularly the cover and title page. Instructions for filing in each block of the form follow. It is important to stay within the lines to meet optical scanning requirements.

Block 1. Agency Use Only (Leave blank)

Block 2. Report Date. Full publication date including day, month, and year, if available (e.g., 1 Jan 88). Must cite at least the year.

Block 3. Type of Report and Dates Covered. State whether report is interim, final, etc. If applicable, enter inclusive report dates (e.g., 10 Jun 87 - 30 Jun 88).

Block 4. Title and Subtitle. A title is taken from the part of the report that provides the most meaningful and complete information. When a report is prepared in more than one volume, report the primary title, add volume number, and include subtitle for the specific volume. On classified documents enter the title classification in parentheses.

Block 5. Funding Numbers. To include contract and grant numbers; may include program element number(s), project number(s), tasks number(s), and work unit number(s). Use the following labels:

C	-	Contract	PR	-	Project
G	-	Grant	TA	-	Task
PE	-	Program Element	WU	-	Work Unit Accession No.

Block 6. Author(s). Name(s) of person(s) responsible for writing the report, performing the research, or credited with the content of the report. If editor or compiler, this should follow the name(s).

Block 7. Performing Organization Name(s) and Address(es). Self-explanatory.

Block 8. Performing Organization Report Number. Enter the unique alphanumeric report number(s) assigned by the organization performing the report.

Block 9. Sponsoring/Monitoring Agency Name(s) and Address(es). Self-explanatory.

Block 10. Sponsoring/Monitoring Agency Reports Number. (if known).

Block 11. Supplementary Notes. Enter information not included elsewhere such as: Prepared in cooperation with ...; Trans. of ...; To be published in ... When a report is revised, include a statement whether the new report supersedes or supplements the older report.

Block 12.a Distribution/Availability Statement. Denotes public availability or limitations. Cite any availability to the public. Enter additional limitations or special markings in all capitals (e.g., NOFORN, REL, ITAR).

DOD - See DoDD 5230.24 "Distribution Statement on Technical Documents

DOE - See authorities.

NASA - See Handbook NHB 2200.2.

NTIS - Leave blank.

Block 12.b Distribution Code.

DOD - Leave blank.

DOE - Enter DOE distribution categories from the standard Distribution for Unclassified Scientific and Technical Reports.

NASA - Leave blank.

NTIS - Leave blank.

Block 13. Abstract. Include a brief (Maximum 200 words) factual summary of the most significant information contained in the report.

Block 14. Subject Terms. Keywords or phrases identifying major subjects in the report.

Block 15. Number of Pages. Enter the total number of pages.

Block 16. Price Code. Enter appropriate price code (NTIS only).

Block 17 - 19. Security Classifications. Self-explanatory. Enter U.S. Security Classification in accordance with U.S. Security Regulations (i.e., UNCLASSIFIED). If form contains classified information, stamp classification on the top and bottom of the page.

Block 20. Limitation of Abstract. This block must be completed to assign a limitation to the abstract. Enter either UL (unlimited) or SAR (same as report). An entry in this block is necessary if the abstract is to be limited. If blank, the abstract is assumed to be unlimited.

REPORT DOCUMENTATION PAGE			Form Approved OMB No. 0704-0188	
Public reporting burden for this collection of information is estimated to average 1 hour per response, including the time for reviewing instructions, searching existing data sources, gathering and maintaining the data needed, and completing and reviewing the collection information. Send comments regarding this burden estimate or any other aspect of this collection of information, including suggestions for reducing this burden, to Washington Headquarters Services, Directorate for Information Operations and Reports, 1215 Jefferson Davis Highway, Suite 1204, Arlington, VA 22202-4302, and to the Office of Management and Budget, Paperwork Reduction Project (0704-0188), Washington, DC 20503.				
1. AGENCY USE ONLY (Leave blank)		2. REPORT DATE	3. REPORT TYPE AND DATES COVERED	
4. TITLE AND SUBTITLE METSAT Advanced Microwave Sounding Unit -A (AMSU-A), Structural Mathematical Model, A1			5. FUNDING NUMBERS NAS 5-32314	
6. AUTHOR(S) R.J. Heffner				
7. PERFORMING ORGANIZATION NAME(S) AND ADDRESS(ES) Aerojet 1100 W. Hollyvale Azusa, CA 91702			8. PERFORMING ORGANIZATION REPORT NUMBER CDRL 102b 10738 1 April 1966	
9. SPONSORING/MONITORING AGENCY NAME(S) AND ADDRESS(ES) NASA Goddard Space Flight Center Greenbelt, Maryland 20771			10. SPONSORING/MONITORING AGENCY REPORT NUMBER ---	
11. SUPPLEMENTARY NOTES ---				
12a. DISTRIBUTION/AVAILABILITY STATEMENT ---			12b. DISTRIBUTION CODE ---	
13. ABSTRACT (Maximum 200 words) This is the METSAT Structural Mathematical Model for the Integrated Advanced Microwave Sounding Unit-A (AMSU-A), A1				
14. SUBJECT TERMS EOS Microwave System			15. NUMBER OF PAGES 152	
			16. PRICE CODE ---	
17. SECURITY CLASSIFICATION OF REPORT Unclassified	18. SECURITY CLASSIFICATION OF THIS PAGE Unclassified	19. SECURITY CLASSIFICATION OF ABSTRACT Unclassified	20. LIMITATION OF ABSTRACT SAR	

TITLE METSAT Advanced Microwave Sounding Unit-A (AMSU-A) Structural Mathematical Model			DOCUMENT NUMBER Report 10738 1 April 1996	
INPUT FROM:	DATE	CDRL: 102B	SPECIFICATION ENGINEER: R. Regehr	DATE 28 Mar 96
CHECKED BY: J. Kirk		DATE 28 Mar 96	JOB NUMBER: _____ DATE _____	
APPROVAL SIGNATURES			DEPT. NO.	DATE
Responsible Engineer (R. Heffner) <u><i>R Heffner</i></u>			8611	3-28-96
Technical Director/Program Office (R. Hauerwaas) <u><i>RH Hauerwaas</i></u>			4001	3/28/96
Performance Assurance (R. Taylor) <u><i>RM Taylor</i></u>			5331	3-28-96
Configuration Management (J. Cavanaugh) <u><i>J Cavanaugh</i></u>			8611	3-28-96
By my signature, I certify the above document has been reviewed by me and concurs with the technical requirements related to my area of responsibility.				
RELEASE (Data Center) FINAL				

Please return this sheet and the reproducible master to the Data Center (119/8651), ext. 2231.				

