

1N-71
0210926

NASA Contractor Report 202305

Ejector Noise Suppression With Auxiliary Jet Injection

Charles H. Berman and Otto P. Andersen, Jr.
AeroChem Research Laboratories, Inc.
Princeton, New Jersey

June 1997

Prepared for
Lewis Research Center
Under Contract NAS3-27246



National Aeronautics and
Space Administration

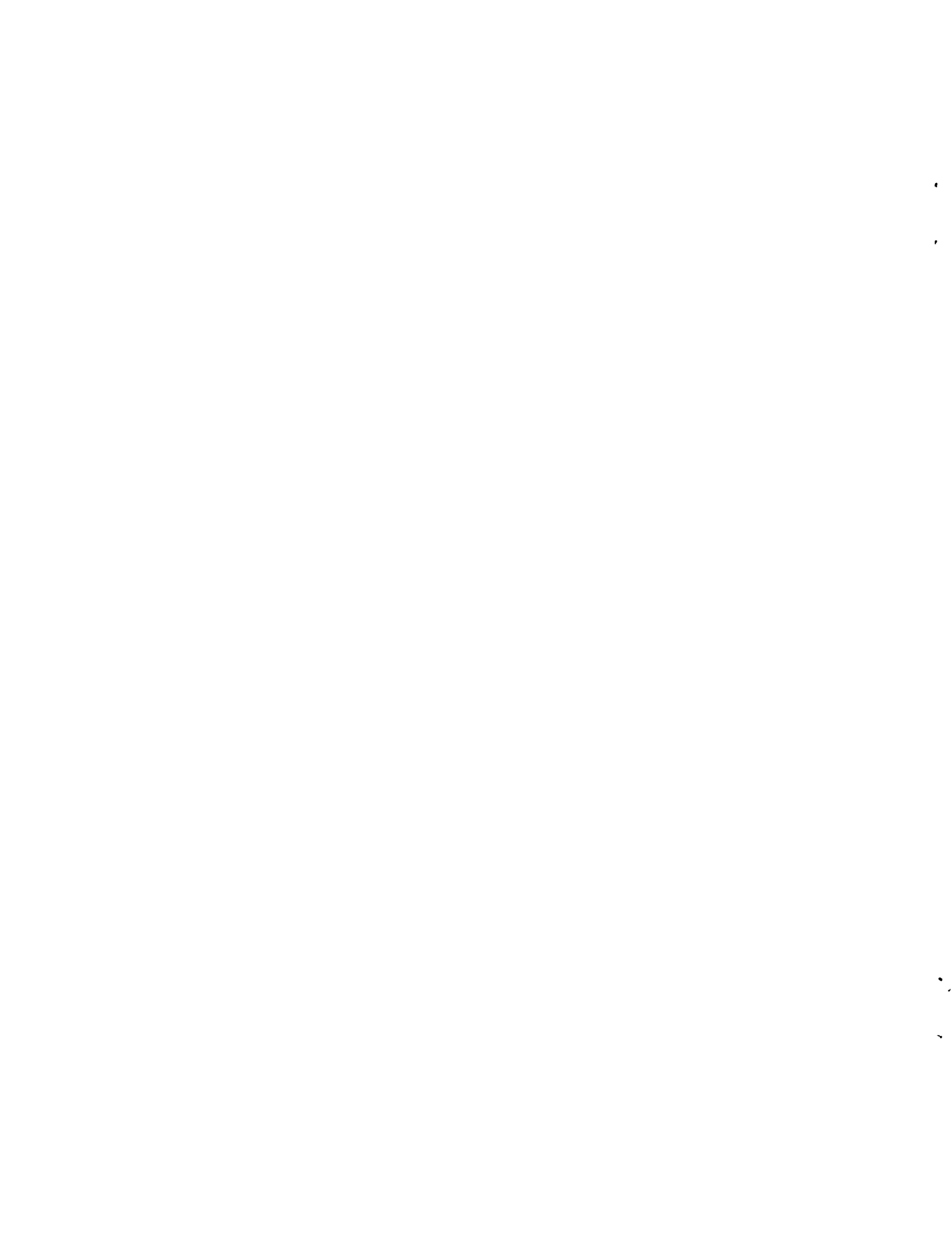

**PROJECT SUMMARY
NASA SBIR PHASE II FINAL REPORT**

CONTRACT NUMBER: NAS3-27246

PROJECT TITLE: Ejector Noise Suppression with Auxiliary Jet Injection

PREPARED BY: AeroChem Research Laboratory, Titan Corporation
P.O. Box 2229, Princeton, NJ 08543-2229

An experimental program to reduce aircraft jet turbulence noise investigated the interaction of small auxiliary jets with a larger main jet. Significant reductions in the far field jet noise were obtained over a range of auxiliary jet pressures and flow rates when used in conjunction with an acoustically lined ejector. While the concept is similar to that of conventional ejector suppressors that use mechanical mixing devices, the present approach should improve thrust and lead to lower weight and less complex noise suppression systems since no hardware needs to be located in the main jet flow. A variety of auxiliary jet and ejector configurations and operating conditions were studied. The best conditions tested produced peak to peak noise reductions ranging from 11 to 16 dB, depending on measurement angle, for auxiliary jet mass flows that were 6.6% of the main jet flow with ejectors that were 8 times the main jet diameter in length. Much larger reductions in noise were found at the original peak frequencies of the unsuppressed jet over a range of far field measurement angles. Potential NASA and commercial applications for Phase III consideration include the reduction of aircraft jet engine exhaust noise and rocket exhaust noise. Additional commercial applications are in the areas of combustion and industrial fluid mixing processes.

KEY WORDS: Noise, Jet Noise, Ejectors, Suppressors, Mixers

SUBMITTED: Charles H. Berman

Charles H. Berman
Principal Investigator

DATE: 2/10/97

AUXILIARY JET IMPINGEMENT TO REDUCE JET NOISE

Charles H. Berman
Fluid Dynamicist

and

Otto P. Andersen, Jr.
Research Associate

AeroChem Research Laboratory, Titan Corporation
Princeton, NJ

ABSTRACT

An experimental program to reduce aircraft jet turbulence noise investigated the interaction of small auxiliary jets with a larger main jet. Significant reductions in the far field jet noise were obtained over a range of auxiliary jet pressures and flow rates when used in conjunction with an acoustically lined ejector. While the concept is similar to that of conventional ejector suppressors that use mechanical mixing devices, the present approach should improve thrust and lead to lower weight and less complex noise suppression systems since no hardware needs to be located in the main jet flow. A variety of auxiliary jet and ejector configurations and operating conditions were studied. The best conditions tested produced peak to peak noise reductions ranging from 11 to 16 dB, depending on measurement angle, for auxiliary jet mass flows that were 6.6% of the main jet flow with ejectors that were 8 times the main jet diameter in length. Much larger reductions in noise were found at the original peak frequencies of the unsuppressed jet over a range of far field measurement angles.

INTRODUCTION AND BACKGROUND

Supersonic jet noise is radiated by turbulent velocity fluctuations and shock interactions in the plume downstream of the jet nozzle. The goal for many jet noise suppression techniques is to increase the mixing between the jet and the ambient air or between the jet and a secondary fan stream so that the length of the high velocity region of the jet is reduced. The mixing techniques usually result in smaller eddies so that there is a shift in the source spectrum from low to high frequencies. However, the implementation of standard mixers¹ for the reduction of jet turbulence noise in practical applications has proven to be a difficult challenge because of the mixers' weight, thrust loss and the complexity of integrating them into a propulsion system (it is desirable that they not be in the jet stream during cruise.)

The Phase I study² found that both ideally and nonideally expanded supersonic jets experienced greatly increased mixing under the action of auxiliary jets that were aimed radially toward the main jet centerline at Reynolds numbers up to 300,000. This occurred for the case of one, two,

and three auxiliary jet configurations and for auxiliary air jets impinging on either air or helium main jets.

In the present study the objective was to measure noise suppression due to auxiliary jets operating with an ejector suppressor at main jet Reynolds numbers above 600,000 to more closely simulate full-scale turbulent phenomena. The basic arrangement is shown in Fig. 1 with the auxiliary jets entering through the ejector suppressor shroud. The auxiliary jet exits have also been placed flush with the ejector walls, and other locations for the auxiliary jet nozzles could be used. Basically the auxiliary jets take the place of mechanical mixers in other designs for ejector suppressors. The auxiliary jets can potentially lead to a lighter weight, lower drag system since no hardware needs to be positioned in the main jet stream. Since mixing is produced by the auxiliary jet fluid instead of hardware, complexities due to stowage after take-off are greatly reduced, if not eliminated. The magnitude and characteristics of the mixing effect are easily controlled by varying the auxiliary jet flow rate and pressure.

Much of the work in the literature on jet interaction has treated the problem of a small jet entering into a large uniform stream through a side wall with the main interest being mixing of the small jet with the larger stream. Injection of subsonic jets into subsonic confined flows was studied by Rudinger³, with the momentum flux being the determining parameter for the penetration distance of a small jet into a larger flow. For injection of nonideally expanded, supersonic jets into supersonic flows, mass flux was reported to be the important parameter⁴. Jet penetration changed little as pressure was raised and diameter reduced to hold mass flow constant.

A physical description of the above interaction for subsonic flow is given by Durando⁵ who models jet injection into a cross flow by the formation of counter-rotating vortices. The transverse force introduced by the jet is analogous to a lift; and lift over a finite span results in axial vorticity in the same manner as the formation of trailing vortices behind a wing. Broadwell and Briedenthal⁶ have performed water experiments on jet injection into transverse streams that quantify the enhanced mixing due to this jet induced vortex system.

Shaw⁷ and Walker⁸ successfully used auxiliary jets that intersected the main jet at a shallow angle to reduce shock tone noise from two nearby interacting main jets.

Reeder and Zaman⁹ found a small effect on jet flow mixing due to injection by a single auxiliary jet through the main jet nozzle wall.

The most relevant work in the literature for our case is that of Davis¹⁰ who investigated the injection of two opposed radial jets into a main jet for subsonic flows. Although his study was motivated by noise reduction, no noise measurements were taken. The present study extends this work to supersonic jet flows and performs noise measurements.

From the point of view of fluid mechanics the unique aspect of our approach is that a relatively small flow stream, the auxiliary jets, is used to enhance the mixing between two larger flow

streams: the main jet and either the ambient environment through which the plane flies or a secondary fan air stream. The auxiliary jets improve the mixing between the main jet and the stream surrounding it in a manner similar to the action of mechanical mixers, but allow easier control of the mixing process without requiring mechanical parts to be in the hot exhaust stream. The amount of momentum that is supplied by the auxiliary jets is small compared to the two streams that are being mixed.

REVIEW OF FLOW RESULTS

Cross-sectional profiles of the total head pressure made in the Phase I program found that a jet is highly distorted by the interaction of auxiliary jets as shown in Fig. 2. In Fig. 3 shadowgraphs obtained in the Phase II program show the interaction of an ideally expanded supersonic main jet with both two and four auxiliary jets which are tilted downstream 30° from the radial orientation of Fig. 1. A sideways compression of the flow is displayed for two jets and a rapid spread occurs for four jets. A typical centerline pressure distribution for the two auxiliary jet case for a nonideally expanded main jet appears in Fig. 4, and a survey across the flow is found in Fig. 5. From these plots it appears that significant mixing has occurred at a distance of 3 to 4 main jet diameters from the nozzle exit. This distance will be important in interpreting the noise results.

EXPERIMENT

Experiments were performed for both ideally and non-ideally expanded flows using main jet nozzles with an exit diameter of 12.7 mm (0.5 inches). For the non-ideally expanded case a round convergent nozzle with a constant area section about $2 D_{jet}$ in length at the nozzle exit provided a supersonic flow with a shock wave structure and shock noise. A convergent-divergent nozzle was also constructed with nearly shock free performance at a Mach number of 1.42.

A Brujel and Kjaer (B&K) Type 4135, 6 mm (1/4 inch), condenser microphone with a B&K Type 2639T preamplifier was used, and the noise was analyzed with a Stanford Research Systems Model SR760 100 kHz, real time, FFT spectrum analyzer. A single microphone was traversed at a distance of 100 main jet diameters from the main jet centerline and at the same height as the jet to measure noise ranging from angles of 90° to 150° from the jet inlet. The microphone body was positioned vertically so that sound waves would travel parallel to the diaphragm face. For this grazing incidence angle the microphone response would be independent of the relative position between any noise source in the jet and the microphone position along the traverse. The microphone was operated with a normal protection grid. The B&K grid calibration curves were extrapolated to obtain the response out to 100 kHz.

Tests were performed in an anechoic chamber with dimensions that were 2.7m (9 ft) x 2.7m x 2.4m (8 ft) (Fig. 6). The chamber was determined to be anechoic (± 1 dB) from below 1 kHz out to 100 kHz by measuring the fall-off in sound level with distance from a 3mm (1/8 inch), high

subsonic Mach number reference jet. This reference jet's noise was measured prior to each day's testing of the larger nozzles to verify that all components of the acoustic system were operating properly.

Air supplied by a Worthington air compressor passed on its way to the jet nozzle through, in turn, a Hankison Model DH80 desiccant dryer, a 660 gallon receiver tank, a Fisher Model 4160K pneumatic pressure regulator equipped with a Whisper III Cage, and a high pressure muffler designed for the project. Separate lines were also connected upstream of the Fisher regulator to the auxiliary jet supply and to the reference jet, both controlled by individual regulators. This setup is shown schematically in Fig. 7.

Thrust was measured with an Omega Model LCCA-25 load cell located at the rear of the nozzle plenum chamber. Care was taken to reduce any constraint to motion of the nozzle assembly against the load cell by suspending the plenum from the vertical air supply pipe which rotated in a ball bearing assembly near the ceiling. The use of flexible plastic tubing at the inlet to the supply pipe also reduced the constraint to motion. By recording thrust at similar conditions for a large number of runs over the course of the program, we estimate that thrust readings were accurate to within $\pm 0.5\%$ of the main jet thrust. Back to back runs are closer in accuracy. Thrust will be reported to the nearest 0.1% since we believe that this shows valid trends.

Noise measurements were made at angles of 90° , 135° , and 150° from the jet inlet to focus on particular physical mechanisms and characteristics. The propagation of sound through flows depends on the ratio of the flow velocity U_{jet} to the acoustic phase velocity v_{phase} relative to the flow direction, there being no flow effect when that ratio is zero. There should be minimal propagation effects at 90° since that velocity ratio is zero due to the phase velocity being infinite. Thus, noise at 90° should depend primarily on the jet turbulence source strength produced by the turbulent fluctuations. The 135° angle is characterized as being close to the jet noise peak angle¹. The 150° angle, close to the jet exhaust direction, should display the effects of the mean flow on sound propagation since the velocity ratio U_{jet}/v_{phase} is close to unity. At low frequencies the propagation path length through the jet is small relative to an acoustic wavelength, and so the propagation effect is small for all angles.

Since the Phase I study² found that two opposed auxiliary jets produced significant distortion of the main jet, the noise was expected to depend on whether the microphone was exposed to the broad side or the narrow side of the resultant jet. Two measurement modes, Configurations I and II illustrated in Fig. 8, were used to explore this dependence. These two configurations were attained by rotating the main jet and the auxiliary jets about the main jet axis with the microphone fixed.

The ejectors tested were positioned inside a metal square tube support structure which was secured to the main jet plenum chamber with rods that were parallel to the main jet axis (Fig. 9). The inside of the square tube was lined with plywood and then acoustically absorbing foam to create ejectors with either a square or a rectangular cross-section. Slots were cut in the forward section of the square tube, plywood and foam to allow arbitrary positioning of the ejector relative to the

auxiliary jets which passed through the slots. For hard walled ejector studies, metal tubes with round and square cross-sections were inserted inside the square box formed by the plywood and acoustic foam. Several cases were treated for the round metal tube. In the first case the tube extended $1 D_{jet}$ upstream of the main jet nozzle exit as shown in Fig. 10a. In another configuration slots were cut in the metal tube to connect with the slots in the support structure (Fig. 10b). In the final configuration the slots were closed and the entire ejector and support structure were pulled downstream of the auxiliary jets (Fig. 10c).

Fig. 11 shows various components used in the experiments including both the main jet nozzles used for the ideally and nonideally expanded flow cases, the ejector support structure, round and square hard walled ejector linings with slots, a wire mesh screen lining to be placed over acoustic foam, a tapered ejector inlet, an auxiliary jet injection tube, and a coaxial tube which was placed directly over the main jet nozzle.

PARAMETRIC DEPENDENCIES

The noise reduction is affected by a number of parameters that describe the ejector and the auxiliary jets. Table 1 indicates that parameters to be considered for an ejector are: lining, length, cross-section, area ratio relative to the main jet nozzle, inlet position, and occurrence of slots. Table 1 shows that the parameters to be considered for auxiliary jets are: number, pressure ratio, flow rate, position relative to the main jet and the ejector, and angle. A series of experiments were performed to determine the effect of variation of these parameters with the prime objective of finding combinations of the parameters that would minimize noise relative to system constraints. For example, any practical system would need to minimize thrust losses, auxiliary jet mass flow, and the shroud length, cross-sectional area and weight while achieving a desired noise reduction goal. Since any particular application would have its own set of constraints, the results presented here can only provide a guide for the direction that should be taken to meet particular requirements.

RESULTS

It will be shown later that noise reduction due to auxiliary jet interaction with an ideally expanded jet relative to the baseline case was nearly identical to that for a nonideally expanded jet for similar test conditions. For that reason we chose to concentrate most of our measurements for only the case of the nonideally expanded jet.

All spectra were plotted as functions of Strouhal number, fD_{jet}/U_{jet} , to generalize the results. As used for this study the Stanford Systems FFT analyzer provided 15 one third octave bands with the actual lower band frequencies ranging from 3.2 to 80 kHz. Low frequencies are characterized by the 5 lowest Strouhal numbers, mid frequencies by the next 5, and high frequencies by the 5 largest Strouhal numbers.

A. No Ejectors

Noise reduction can be achieved without an ejector as shown by the noise results for two auxiliary jets in Fig. 12. Two auxiliary jets produce significant distortion of the main jet as shown earlier in the report. At 90° to the inlet axis the major effect of the auxiliary jets is to reduce the shock noise. Note that the noise of the baseline case of no auxiliary jets and no ejector changes with microphone orientation due to slight imperfections in the nozzle that affect the shock structure. Increases in noise with the auxiliary jets on may be due to additional noise generated by the mixing process between the main and auxiliary jets. The baseline case for all future comparisons will be the curve with the smaller peak.

Two mechanisms that lead to noise reduction at 150° in Fig. 12 are directional shielding of sound produced by the nonaxisymmetric deformation of the main jet and enhanced mixing between the main jet and the ambient fluid caused, at least in part, by that same deformation. The shielding mechanism is evidenced by the difference in sound level at mid and high frequencies for the two main jet orientations relative to the microphone. Noise is reduced at these frequencies when the microphone views the narrow side of the deformed main jet (Fig. 8) and makes an acute angle with the main jet axis. This leads to a condition of sound wave attenuation based on fundamental principles for the propagation of sound in fluids. The path length for waves traveling through the flow is longer than for the undistorted case so that attenuation proceeds over a longer distance.

Noise from the broad side of the jet is increased because there is more surface area for radiation, and the narrowness in the other direction provides a minimal path length for waves in the jet that are experiencing attenuation by the flow.

The deformed main jet shape increases the surface area for mixing; and other interactions such as turbulence production may also enhance the mixing. The reduction in low frequency noise is a result of a shortening of the length of the region containing the large scale eddies and a lowering of the jet velocities there. Note that the low frequency noise reduction at 150° is similar in Fig. 12 for both the broad and narrow side microphone positions since the ratio of the path length to the wavelength is too short for any significant attenuation to occur.

In the case of four auxiliary jets (all four either radial, 0° orientation, or angled downstream) the deformed main jet must display some greater degree of symmetry than for two auxiliary jets. The Strouhal number spectrum for four jets displayed in Fig. 13 is typical of that of a multi-element mixer nozzle¹ since the low frequency noise is reduced and the higher frequency noise is increased. The increased noise is clearly present at 135° and 150° . In this case the auxiliary jets were located $0.25 D_{jet}$ downstream of the main jet nozzle exit and $0.3125 D_{jet}$ from the outer surface of the main jet nozzle.

Tilting the four auxiliary jets in the downstream direction at an angle of 30° from their radial (0°) position resulted in nearly identical noise levels compared to the radial jet case at the lowest measured frequency, slightly greater levels at somewhat higher frequencies and reduced levels at mid

and high frequencies (Fig. 13). The only other case to be treated with angled auxiliary jets is for a lined ejector, which will be discussed later.

B. Hard Walled Ejectors

1. Plain Tube

Since the effect of an ejector with the auxiliary jets off was small compared to the case of the auxiliary jets on, we only report the latter cases. This was true whether the ejector was acoustically lined or hard walled.

Fig. 14 displays the effect of hard walled ejectors with 4 radial auxiliary jet flows. An ejector consisting of a simple round tube (Fig. 10a) produces significant noise reduction except at the lowest frequencies. The ejector tube's inside diameter is $2 D_{jet}$ and it extends $8 D_{jet}$ downstream and $1 D_{jet}$ upstream of the main jet nozzle exit.

2. Slots

In an attempt to increase the mixing efficiency, slots were cut in the ejector wall so that additional external air could be drawn into the ejector (Fig. 10b). Without slots strong recirculation regions would be formed that could limit the amount of the auxiliary jets' linear momentum that would reach the main jet flow.

Experiments were performed to examine the effect of slot position and length. One experiment used $0.375 D_{jet}$ wide slots that were cut through the ejector inlet and extended from there to the auxiliary jet tubes, a distance of $1.25 D_{jet}$. For a second experiment the slots upstream of the auxiliary jets were taped over and the slots continued a distance of $1 D_{jet}$ downstream of the auxiliary jet tubes. In the third experiment both the upstream and downstream slots were open. A final experiment had a square cross-section hard walled ejector with upstream slots similar to those of the round tube case. The effect of slots on lined ejector performance will be described shortly.

The unslotted tube results are compared with the upstream slot case in Fig. 14. This particular upstream slot configuration with 5.6% auxiliary jet mass flow will be denoted as the standard slot case. The open area of these slots is about 2.4 times the main jet nozzle area and 60% of the ejector inlet area. The standard slot case clearly produces less low frequency noise than the unslotted case.

The standard slot case gave the largest noise reductions with greater consistency than the other configurations as seen in Fig. 15. A square cross-section metal ejector the same overall length of the tube and with slots the same length as the standard slot case was substituted for the round cross-section ejector and produced similar results, as shown in Fig. 15. The square cross-section was $1.875 D_{jet}$ on a side and had a cross-sectional area 4.47 times that of the main jet's compared to 4 for the round tube.

3. Increased Flow Rate

The effect of increased auxiliary jet flow rate was tested by raising the total pressure ratio from 3.72 to 4.4. Fig. 16 compares the noise of the standard slot case with the same slot geometry at the higher flow rate of 6.6%. The higher flow results in significant improvement except at the lowest frequencies.

4. Ejector Position

To study the effect of a different ejector inlet location, the slots were covered with tape and the entire ejector was moved just downstream of the auxiliary jet tubes with the auxiliary jets fixed relative to the main jet nozzle as in Fig. 10c. Thus, the new ejector began more than $0.5 D_{jet}$ downstream of the main jet nozzle.

Fig. 17 compares the higher flow rate cases for the downstream tube and the slotted tube both at the higher flow rate of 6.6%. The downstream tube case compares quite well with the slotted case except at low frequencies and at 150° .

C. Lined Ejectors

Since realistic ejector-suppressors utilize acoustically absorbing linings, experiments were performed with a commercial urethane foam, bulk material which absorbed sound over a wide frequency range. Square and rectangular cross-section ejectors were used for all of the lining tests since the straight sides simplified installation of the sound absorbing foam material, which was attached to the inside of the ejector shroud with double-sided tape. Although there may be some differences if an acoustically lined circular cross-sectioned tube had been used, we note that there was virtually no difference in the results for round and square cross-sections for the hard walled cases.

1. Slots

Results are shown in Fig. 18 for a smooth $0.5 D_{jet}$ thick foam lining (the unslotted case) in an $8 D_{jet}$ long ejector with a square cross-section, equal nozzle and main jet pressure ratios of 3.72 and a total auxiliary jet mass flow of 5.6%. With slots in the ejector shroud and foam, the corresponding curve in Fig. 18 shows substantial noise reduction in the mid and high frequency regions. The low frequency sound reduction becomes less effective compared to the unslotted case as the observation angle approaches 90° .

Covering the slotted foam with a wire mesh screen (100 mesh, 30% open area) improves the low frequency performance without severely decreasing the high frequency characteristics as seen in Fig. 18.

2. Angled Auxiliary Jets

Experiments were performed with square and rectangular lined ejectors and 4 auxiliary jets tilted at an angle of 30° from the radial position with a component in the main jet flow direction. For the square ejector case, Fig. 19 shows that the radial jets produce lower noise than the 30° jets except for the lowest frequencies.

3. Rectangular Ejector Orientation

When the ejector has a rectangular cross-section, the mid frequency noise is reduced if the narrow side of the ejector is viewed by the microphone as shown in Fig. 20. This is similar to the case shown in Fig. 12 where the noise viewed from the broad side of the jet, caused by deformation by a two auxiliary jet system, was greater than the noise from the narrow side. However, an additional mechanism may be an interaction of the jet flow with the ejector itself. For example, noise produced by the interaction of turbulence with the ejector edges would be larger for the broad side orientation since there is a wider edge that is viewed. A mechanism for noise production is the edge noise phenomenon¹¹.

4. Lined Ejector Length

The effect of lined ejector length on noise reduction is shown in Fig. 21 for a rectangular cross-section ejector and two auxiliary jets operating at $\text{NPR}=2.14$ and a mass flow of 5.6% of the main jet's. At an ejector length L_{ej} to main jet diameter D_{jet} the suppression has basically disappeared at the two higher angles and only exists in the mid frequency range at 90° .

5. Ejector Shield Extension

In Fig. 22 the case of an ejector with $L_{ej}/D_{jet}=10$ is compared with a device of the same total length made up of a shorter ejector with $L_{ej}/D_{jet}=4$ followed by a planar shield between the jet and the microphone which is $6 D_{jet}$ long and $12 D_{jet}$ wide. The combination has good performance relative to the long ejector for the two smaller angles, but reduced performance at the largest angle.

D. Short Ejectors

The basic noise measurement program was concluded by finding the noise from an ejector that extended four main jet diameters downstream of the nozzle exit, half the ejector length for most of our studies. The main jet was kept at the same mass flow with $\text{NPR}=3.72$. The four auxiliary jets were operated at the higher flow rate of 6.6% of the main jet's, corresponding to $\text{NPR}=4.4$.

The results in Fig. 23 compare the cases of long and short slotted tubes at the same auxiliary jet flow rate. Depending on the measurement angle and the frequency, roughly half of the long tube's noise suppression is lost when the ejector length is halved. The case of a short downstream

ejector tube operating at the same flow conditions has characteristics similar to that of the short slotted tube as shown in the same figure.

Measurements were taken with a short square cross-section hard walled ejector at the same flow conditions. However, compared to the round tube case there was no demonstrated improvement in the noise in the mid or high frequency ranges, and the noise reduction was diminished at low frequencies.

When results for a short square foam lined ejector at the same flow conditions were compared to the round hard walled tube, there were slight improvements at high frequencies (but little or no improvement relative to the baseline case), little change at mid frequencies, and a 2 dB increase in the noise level at low frequencies.

E. Ideally Expanded Jet Nozzle

Experiments were carried out at NPR=3.24 with a convergent-divergent main jet nozzle to achieve an ideal expansion. Noise suppression was measured relative to the convergent nozzle operating at the above pressure ratio. Since the convergent nozzle's throat is a little larger than the convergent-divergent nozzle's, the baseline values are high by about 0.75 dB. Results are shown in Fig. 24 for the noise due to the convergent-divergent nozzle operating in a lined rectangular ejector for separate cases of two and four auxiliary jets.

A comparison of the amount of suppression attained for the convergent nozzle and the convergent-divergent nozzle is displayed in Fig. 25. The spikes seen in the convergent-divergent nozzle curve are due to corresponding variations in the baseline nozzle results at that pressure ratio. Thus, the incorporation of an auxiliary jet system with a convergent-divergent nozzle does not lead to any marked difference in the noise suppression. The major advantage is in the thrust performance which will be discussed later.

F. Parametric Trends

1. Momentum Dependence

An assessment of the dominant parameters was made by considering the mid frequency range as being the most important one since the peak noise is often found in that range. Data for lined rectangular ducts were examined for both two and four auxiliary jet systems. Noise suppression is plotted in Fig. 26 as a function of the percentage of auxiliary jet momentum relative to the main jet for the three measurement angles reported and an ejector length equal to $8 D_{jet}$. The data is nearly linear in mass flow at all the angles with the curve for 90° passing through the zero mass flow, zero suppression point. While the other curves must also eventually reach that zero point, they appear to intersect zero suppression at a finite mass flow. Thus, there must be a nonlinear region.

A more detailed picture is provided by looking at the complete spectra of Fig. 27 for the cases corresponding to the two highest values of momentum in Fig. 26. The amount of noise suppression is close except for one region. While the momenta are nearly the same, the mass flows and pressure ratios are vastly different, one corresponding to subsonic and one to supersonic flow.

2. Ejector Length

The effect of ejector length is shown in Fig. 28 for the mid frequency range and in Fig. 29 for the high frequency range. Data for the low frequency range are not shown because we believe that they are strongly influenced by a noise generating interaction with the lining. The results show that noise suppression requires a minimum length of lining before it can lead to a net noise reduction except for the 90° mid frequency case which appears to provide increasing suppression as the ejector is increased from zero length.

3. Other Jet Configurations

An assessment of the mixing capabilities of other auxiliary jet configurations was studied by examining shadowgraphs of the effect on the overall shock structure. In addition to the angled jets the case of two vertical opposed jets at one axial location and two horizontal opposed jets at a second downstream location was studied. However, the amount of noise suppression was much smaller than that for the other cases.

Additional variations in auxiliary jet location were tried. Moving the auxiliary jets short distances upstream or downstream made little difference in the noise levels. Moving the jets radially outward so that they were flush with the ejector wall reduced the noise suppression by up to 1 dB in certain frequency ranges.

G. Thrust

Optimization of thrust was not a prime objective of this program because of the difficulty in producing low drag shapes for all the components used at the small scales of the tests. The major emphasis was on noise reduction techniques and the construction of hardware that would facilitate the rapid variation of components to test ideas for increased noise suppression.

However, thrust was recorded for most of the noise tests, and there were definite trends that will be reported. The structure that was used to house and support the various ejectors studied in the noise tests, had an overall square cross-section, $8 D_{jet}$ on a side. This entire cross-section was generally closed off to air flow except for the middle where the ejector was located.

The effect of the ejector, the support structure, and the mixing processes are summarized as follows. Ambient airflow that is drawn into the ejector experiences reduced pressure as it moves and accelerates over the front surface of the ejector and the support structure. This reduced pressure leads to a thrust. On the other hand the air flow that leaves the ejector entrains additional

ambient air which travels from the upstream side of the support structure to its downstream side. This airflow would be expected to separate from the downstream side of the support structure, leaving a lower pressure region that results in drag (so-called "boat-tail" drag) that acts counter to the thrust generated at the ejector entrance. In addition, there is internal friction drag due to airflow within the ejector. Changes in the cross-sectional area of the ejector can be made to further increase thrust, but this was not pursued.

Thrust measured for the baseline case of no ejector, no support structure, and no auxiliary jet operation was used as the standard of comparison. With a square cross-section metal ejector lining having an area ratio of 4.47, operation of the convergent nozzle with the auxiliary jets off led to a thrust increase of 1.5%. With four radial auxiliary jets operating with a mass flow of 5.6% of the main jet's, the thrust decreased 1% relative to the baseline. For a round ejector tube the thrust increased by 0.7% without auxiliary jet operation, and it is decreased by 1.6% with them on. Operation with the foam lining in a square ejector decreased the thrust by 1.7% without auxiliary jets and by 14.3% with them. When the wire screen was placed over the foam, the thrust was reduced by 1.1% with the jets off and by 7.1% with them on. Thus, the screen greatly reduced the thrust loss.

An interesting test involved the installation of a coaxial tube that fit snugly over the main jet nozzle and extended downstream of it. The auxiliary jets entered through the side wall of the coaxial tube at a point downstream of the main jet exit. Thrust with the auxiliary jets off resulted in a 2.5% thrust loss and operation with them on produced a lower loss of 0.6%. This condition was not pursued because the noise suppression was negligible.

When the four auxiliary jets were angled downstream at 30° from the radial direction, the thrust was increased by 2.2% with no ejector or support structure in place. When a lined rectangular ejector was installed, the thrust was decreased by 5.3% when the angled auxiliary jets were used. Thus, the thrust loss for the angled jets was significantly smaller than the 14.3% experienced for the radial jets. We would expect the thrust loss to be smaller if the angled jets were used with wire screen over the foam lining, but thrust measurements for this case were not taken. A specially shaped inlet (a cone with a 30° half angle) increased the thrust but produced excessive low frequency noise.

The most significant increases in thrust occurred for the high pressure, higher flow rate cases of 6.6% of the main jet's flow with the round, hard walled ejector located downstream of the radial auxiliary jets. Here the thrust increased 3.9% with the jets off and 2.9% with them on. When the ejector was shortened, the thrust increased by 2.3% relative to the baseline case for both the auxiliary jets on and off.

These results and results for other cases are summarized in Table 2.

DISCUSSION OF RESULTS

A. Mechanisms

The preceding results have shown that hard walled linings can greatly reduce low frequency noise while acoustically absorbing foam performs best at higher frequencies. We next hypothesize that an ideal lining may be found possessing the properties of hard wall ejectors for low frequencies and the properties of foam lined ejectors at higher frequencies. The spectra for such a lining are plotted as the composite curve in Fig. 30 by using the lower of the values at each frequency from the case of the hard walled, slotted tube (Fig. 14) and the case of the foam lined, slotted box from previous examples (Fig. 18). In these cases there are four radial auxiliary jets with a total mass flow of 5.6% of the main jet's operating at the main jet pressure ratio and the ejector length is eight times the main jet diameter.

The composite curve is plotted in Fig. 30 along with the results for an earlier test in which the foam lining was covered with a wire mesh screen. The screen provides enough flow resistance to improve the low frequency performance of foam liners while not sacrificing much in terms of their high frequency performance. Thus, some other combination of sound absorbing and flow resistive materials may result in values closer to those of the composite curve.

A problem arose in assessing the noise reduction potential of the higher flow rate auxiliary jets (6.6% of the main jet's mass flow) because data had been obtained for only the hard walled ejector case. To generate an estimate for the lined ejector case similar to that used to generate Fig. 30, we simply lowered the noise curve obtained with a slotted foam lining at 5.6% mass flow in Fig. 18 by the improvement found between the 6.6% and 5.6% hard walled cases in Fig. 16. A new simulated composite curve, shown in Fig. 31 was formed from the lowest noise levels of the corrected lined ejector curve and the measured hard wall ejector curve at each frequency.

The potential for large reductions in jet turbulence noise has been demonstrated. This has been accomplished with auxiliary jet mass flows on the order of 5.6 to 6.6% of the main jet mass flow and ejector lengths that are 8 times the main jet diameter in length from the main jet nozzle exit to the ejector exit. The total length of the ejector, including the portion that extended upstream of the main nozzle exit, is $9 D_{jet}$.

The noise reductions for the best cases at 5.6% and 6.6% mass flows are summarized in Table 3. The largest reductions occur at 90° and 150° . The baseline noise at 90° contains a substantial amount of shock noise which is easily eliminated by the auxiliary jets. The large reduction in the low frequency noise at 150° is indicative of good mixing. The major difference between the 135° and 150° cases is that the phase velocity v_{phase} in the main flow direction is smaller at 150° so that the ratio of U_{jet}/v_{phase} is larger. For larger values of U_{jet} typical of real jet engines this ratio would also be larger at 135° . Thus, we might expect to find more noise reduction in that case.

Alternatively, there are other approaches that can be taken. For example, it has been shown that a similar amount of noise reduction can be achieved at lower auxiliary jet pressure ratios if the total mass flow is increased to maintain the same momentum. The choice would depend on the details of the engine cycle.

B. Hardware Considerations

It is also clear that the mid and high frequency noise can be substantially reduced by making a long enough lined ejector. However, the hard walled ejectors can be quite effective for the low frequencies and portions of the mid frequency range, especially if the auxiliary jet mass flow is increased. For the cases studied here, it appeared that lined ejectors needed to extend more than $4D_{jet}$ downstream of the main nozzle exit to make effective use of the lining. For hard walled ejectors, with auxiliary jets operating at the highest momentum flow, the suppression at low and mid frequencies seemed to scale roughly with the ejector length. Thus, the suppression for an ejector that is $4D_{jet}$ long is about half of that for an $8D_{jet}$ ejector.

The above discussion on ejector length effects is directly related to duct propagation and radiation characteristics in addition to consideration of the noise source location. In addition to sound absorption by the foam lining there is also sound attenuation in the hard walled ejectors due to the cutoff phenomenon¹². These explanations are consistent with the linear dependence of suppression in decibels with ejector length.

Details concerning the design of the ejector inlet shape and location can have an important effect on the low frequency noise. We view reductions in low frequency noise as being indicative of the overall degree of mixing achieved by the auxiliary jet/ejector combination. The greatest low frequency reduction was achieved using slots in the upstream portion of the ejector. The slots may be beneficial for more than one reason. First, the area for entraining ambient air is increased. Secondly, the absence of a wall at the slot position may allow deeper penetration of the auxiliary jet flow into the main jet since a wall would impose a boundary condition that would require a recirculating flow region. Finally, any vortices shed from the slot edges would increase the mixing process.

The slotted ejector might have more potential than we have found. This is because we have not studied variations in slot width, which could lead to increased mixing. Limitations caused by the airflow path through the current slots may limit the amount of air entrained since air that passes through the slots must also pass through slots in the support structure that are $2 D_{jet}$ in depth (Fig. 10b). A more realistic open ejector could lead to greater mixing for the slot case.

The use of a more downstream location for the ejector is a viable alternative. This is especially true when a lined ejector is used because the lining provides additional mid frequency suppression. Pros and cons that must be weighed if a downstream location for the ejector is to be used are a possible loss of suppression at angles less than 90° to the engine inlet axis vs an increase in thrust. However, one reason why this downstream location might be effective in suppressing

noise at small angles is that complete mixing does not occur for some distance beyond the main jet nozzle exit. In this case the noise generated by strong mixing is contained within the ejector even though there is an open gap between the main jet nozzle and the ejector.

One advantage of an auxiliary jet system is that the main nozzle can be designed to provide optimum thrust through the use of a convergent-divergent nozzle to produce ideally expanded flow. Computations we performed showed that there is a wide range of nonideal pressure ratios for which a convergent-divergent nozzle can be operated and still maintain substantial improvements over a convergent nozzle. One obtains degraded performance for a convergent-divergent nozzle only when operating at supersonic pressure ratios well below the design pressure ratio.

CONSIDERATIONS FOR FUTURE APPLICATIONS

The current experiments were carried out with an unheated jet flow that limited the ideally expanded main jet velocity to 1400 ft/s (427 m/s). Work with other types of noise suppressors often shows a trend of increased noise suppression with increasing jet velocity¹. While we don't know how suppression based on the auxiliary jet interaction will behave at higher velocities, experiments at higher velocities could demonstrate that even greater amounts of suppression are possible. Higher velocities would be achieved with a heated jet facility.

Perhaps the biggest problem in terms of implementation of the concept is the length of the ejector required to attain large amounts of suppression. The ejector length could be shortened by having an engine exhaust split into more than one nozzle (although this would increase the hardware complexity that we are trying to avoid) or by going to a rectangular nozzle with the characteristic dimension for mixing being the short side of the nozzle. Since practical engine installations have a centerbody plug at the engine exhaust, the annular jet flow over the plug has a thickness which is much smaller than the jet radius without the plug. The plug effect is also utilized in some current design mechanical flow mixers and noise suppressors.

While we don't know the result of auxiliary jet interaction with the flow passing over a plug, we would expect that it would be quite strong since the plug surface would require those portions of the main jet flow in contact with the auxiliary jets to move away from the plug. In this case the characteristic dimension would be the actual flow thickness so that a shorter ejector could be utilized. The increased interaction would increase the mixing rate, also allowing a shorter ejector, or enabling the use of lower mass injection rates.

Other possible variations would include injecting some of the auxiliary flow outward from the plug wall and using auxiliary jets with a time-varying mass flow.

One parameter that was not fully studied was the ratio of the ejector area to the main jet nozzle area. All of the values studied were large, e.g., greater than 4. The use of a smaller area ratio would make sound waves hit a lined ejector wall at a shorter axial distance so that a shorter

ejector would achieve the same amount of sound absorption as attained by a longer higher area ratio ejector.

Another option that we did not pursue fully was the use of angled jets. In the case of no ejector the angled jet suppression was comparable to that of the radial jets except for the high frequencies where the angled jets produced less noise than the radial jets. The angled jets also yielded relatively good results for the lined jet case. Another advantage is the improved thrust since a component of the auxiliary jet momentum is directed along the main jet axis. An interesting combination would be using angled auxiliary jets directed into an ejector at a more downstream location. In this way one might benefit from additive thrust effects of both configurations.

An aircraft systems problem that must be addressed to make the use of auxiliary jets practical is obtaining sufficient airflow to supply the auxiliary jets. Work is currently being performed to seek means to utilize onboard systems to provide air for injection into the engine nozzle to provide flow area ratio control and thrust vectoring¹³. Full scale engine tests have been performed to supply engine air for aerodynamic control¹⁴.

CONCLUSIONS

A novel method that uses auxiliary jets to mix a main jet flow with the ambient air has been combined with ejector technology to achieve significant reductions in jet turbulence noise.

Auxiliary jet momentum flow is a key parameter that determines the amount of suppression.

For hard walled ejectors, the suppression is roughly proportional to the ejector length with the major suppression occurring in the low and mid frequency ranges.

For lined ejectors, suppression in the mid and high frequency ranges requires a minimum ejector length before the lining is effective.

A variety of details about the ejector shape and location control the low frequency noise suppression of hard walled ejectors. A basic requirement for effective noise suppression is a capability to entrain sufficient air into the mixing region. This applies as well for lined ejectors where ejector slots reduce the noise level for the mid and high frequency ranges.

Angled auxiliary jets can produce significant amounts of noise suppression while either increasing the thrust or reducing thrust losses.

REFERENCES

1. Gliebe, P.R., Brausch, J.F., Majigi, R.K., and Lee, R., "Jet Noise Suppression," Chap. 15 in Aeroacoustics of Flight Vehicles: Theory and Practice, Vol. 2: Noise Control, edited by H.H. Hubbard, NASA Reference Publication 1258, Vol. 2, WRDC Technical Report 90-3052 (1991).
2. Berman, C.H. and Dreizin, E.L., "Auxiliary Jet Impingement to Reduce Jet Noise," Phase I Final Report, Contract NAS3-26720 LERC, AeroChem TP-521 (1993).
3. Rudinger, G., "Experimental Investigation of Gas Injection through a Transverse Slot into a Subsonic Cross Flow," *AIAA J.* **12**, 566 (1974).
4. Billig, F.S., Orth, R.C., and Lasky, M., "A Unified Analysis of Gaseous Jet Penetration," *AIAA J.* **9**, 1048 (1971).
5. Durando, N.A., "Vortices Induced in a Jet by a Subsonic Cross Flow," *AIAA J.* **9**, 325 (1971).
6. Broadwell, J.E. and Briedenthal, R.E., "Structure and Mixing of a Transverse Jet in Incompressible Flow," *J. Fluid Mech.* **148**, 405 (1984).
7. Shaw, L., "Twin-Jet Screech Suppression," *J. Aircraft* **27**, 708 (1990).
8. Walker, S., "Twin Jet Screech Suppression Concepts Tested for 4.7% Axisymmetric and Two-Dimensional Nozzle Configurations," AIAA Paper 90-2150 (1990).
9. Reeder, M.F. and Zaman, K.B.M.Q., "The Impact of 'Tab' Location Relative to the Nozzle Exit on Jet Distortion," AIAA Paper 94-3385 (1994).
10. Davis, M.R., "Variable Control of Jet Decay," *AIAA J.* **20**, 606 (1982).
11. Crighton, D., "Airframe Noise," Chap. 7 in Aeroacoustics of Flight Vehicles: Theory and Practice, Vol. 1: Noise Sources, edited by H.H. Hubbard, NASA Reference Publication 1258, Vol. 1, WRDC Technical Report 90-3052 (1991).
12. Morse, P.M. and Ingard, K.U., Theoretical Acoustics (Princeton University Press, Princeton, 1968).
13. Federspiel, J., Bangert, L., Wing, D., and Hawkes, T., "Fluidic Control of Nozzle Flow - Some Performance Measurements," AIAA Paper 95-2605 (1995).
14. Yuhas, A.J. and Ray, R.T., "Effects of Bleed Air Extraction on Thrust on the F404-GE-400 Turbofan Engine," NASA TM-104247 (1992).

TABLE 1 SYSTEM PARAMETERS STUDIED			
EJECTOR		AUXILIARY JETS	
Variables	Range	Variables	Range
Lining	Hard wall Foam Wire mesh screen over foam	Number	2 and 4
Length	4 to 12 D_{jet} No ejector	NPR	1.69 to 4.4
Cross-Section	Round Square Rectangular	% Main Jet Flow	5.6 to 8.1
Area Ratio	4 to 10.7	Position	Axial: 0.125 to 0.375 D_{jet} Radial: 0.125 D_{jet} from nozzle outer wall to flush with ejector wall
Inlet Position	1 D_{jet} upstream Downstream of auxiliary jets	Angle	-30 0 (radial) 30
Modifications	Slots No slots		

TABLE 2 THRUST DEPENDENCE ON GEOMETRY AND AUXILIARY JET FLOW						
Thrust Changes Relative to Baseline Case						
All auxiliary jet flows 5.6% unless otherwise noted						
EJECTOR			AUXILIARY JETS			%THRUST INCREASE
On/Off	Lining	Cross-section	Angle	On/Off	Other Features	
off	*****	*****	30	on	*****	2.2
off	*****	*****	0	off	coaxial tube*	-2.5
off	*****	*****	0	on	coaxial tube*	-0.6
on	foam	rectangle	30	off	*****	-1.9
on	foam	rectangle	30	on	*****	-5.3
on	foam	square	30	off	*****	-1.2
on	foam	square	30	on	*****	-10.1
on	foam	square	-30	off	*****	-2.2
on	foam	square	-30	on	*****	-20.2
on	foam	square	0	off	*****	-1.7
on	foam	square	0	on	*****	-14.3
on	screen over foam	square	0	off	upstream slots	-1.1
on	screen over foam	square	0	on	upstream slots	-7.1
on	metal	square	0	off	upstream slots	1.5
on	metal	square	0	on	upstream slots	-1
on	metal	round	0	off	no slots	0.7
on	metal	round	0	on	no slots	-1.6
on	metal	round	0	off	shaped inlet	4.4
on	metal	round	0	on	shaped inlet	1
on	metal	round	0	off	upstream slots	-1.5
on	metal	round	0	on	upstream slots	-3.2
on	metal	round	0	off	long slots	-1.3
on	metal	round	0	on	long slots	-2.1
on	metal	round	0	off	upstream slots**	0.2
on	metal	round	0	on	upstream slots**	-2.5
on	metal	round	0	off	upstream slots, short tube**	1
on	metal	round	0	on	upstream slots, short tube**	-0.6
on	metal	round	0	off	downstream tube**	3.9
on	metal	round	0	on	downstream tube**	2.9
on	metal	round	0	off	short downstream tube**	2.3
on	metal	round	0	on	short downstream tube**	2.3

*Tube extension over main jet nozzle
 **Auxiliary jet mass flow=6.6% of main jet

TABLE 3 COMPARISON OF NOISE REDUCTIONS * Auxiliary jet mass flow = 5.6% of main jet ** Auxiliary jet mass flow = 6.6% of main jet						
Microphone Angle to Jet Inlet	Peak to peak noise reduction, dB			OASPL noise reduction, dB		
	90	135	150	90	135	150
Composite Case*	18.3	10.3	16.2	14.9	9.5	15.8
Screen over foam*	16.3	7.5	13.2	13.4	8	13.5
High flow simulation**	19.1	11.1	16.3	16.5	11	16

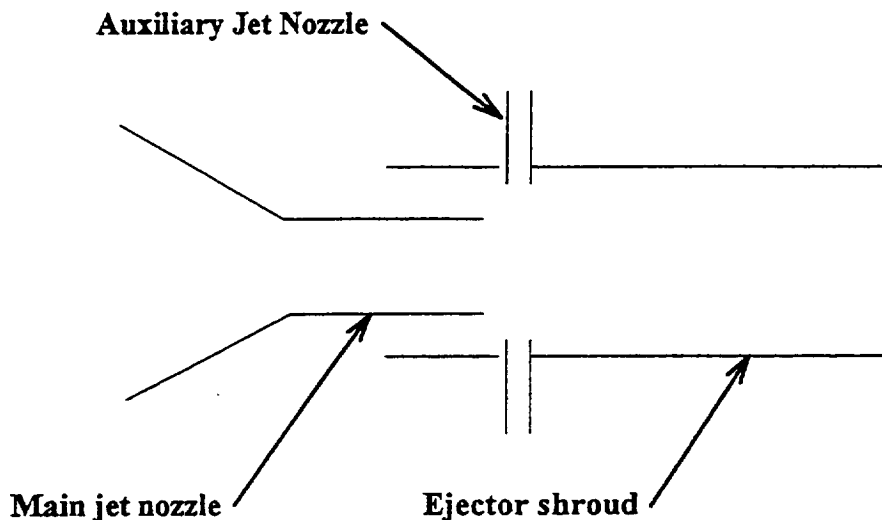

Fig. 1 Ejector Suppressor with Auxiliary Jet Mixing

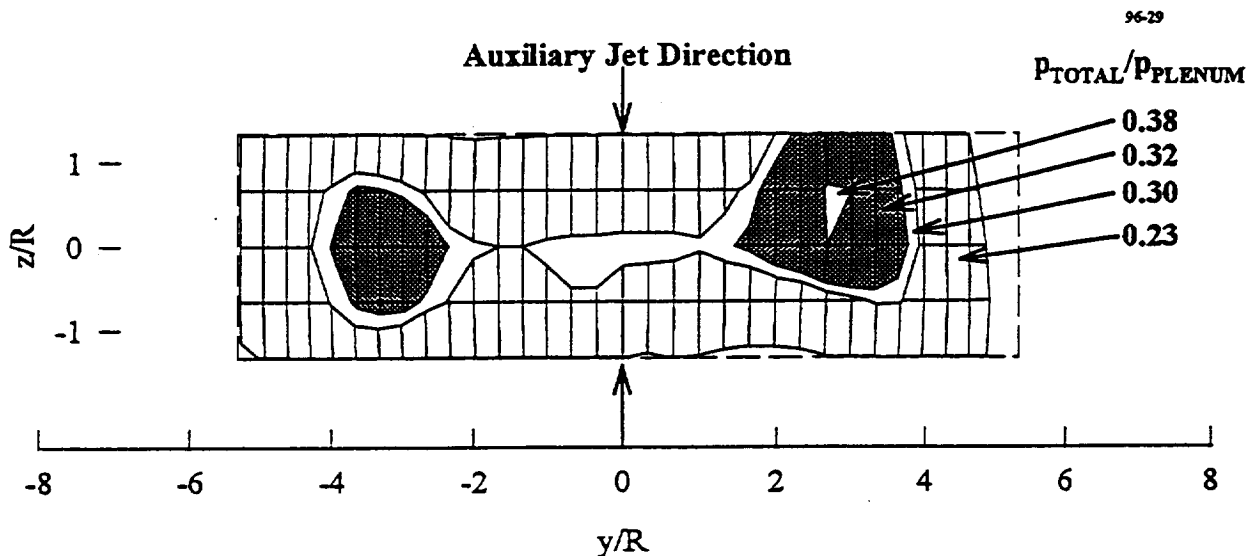

Fig. 2 Measured Total Pressure Contours for an Underexpanded Air Jet
 $x/R = 10$
 Main jet NPR = 4.47
 2 Auxiliary Jets with NPR = 4.1
 Auxiliary Jet Mass Flow = 7.7% of Main Jet
 Sonic $p_{TOTAL}/p_{PLENUM} = 0.42$

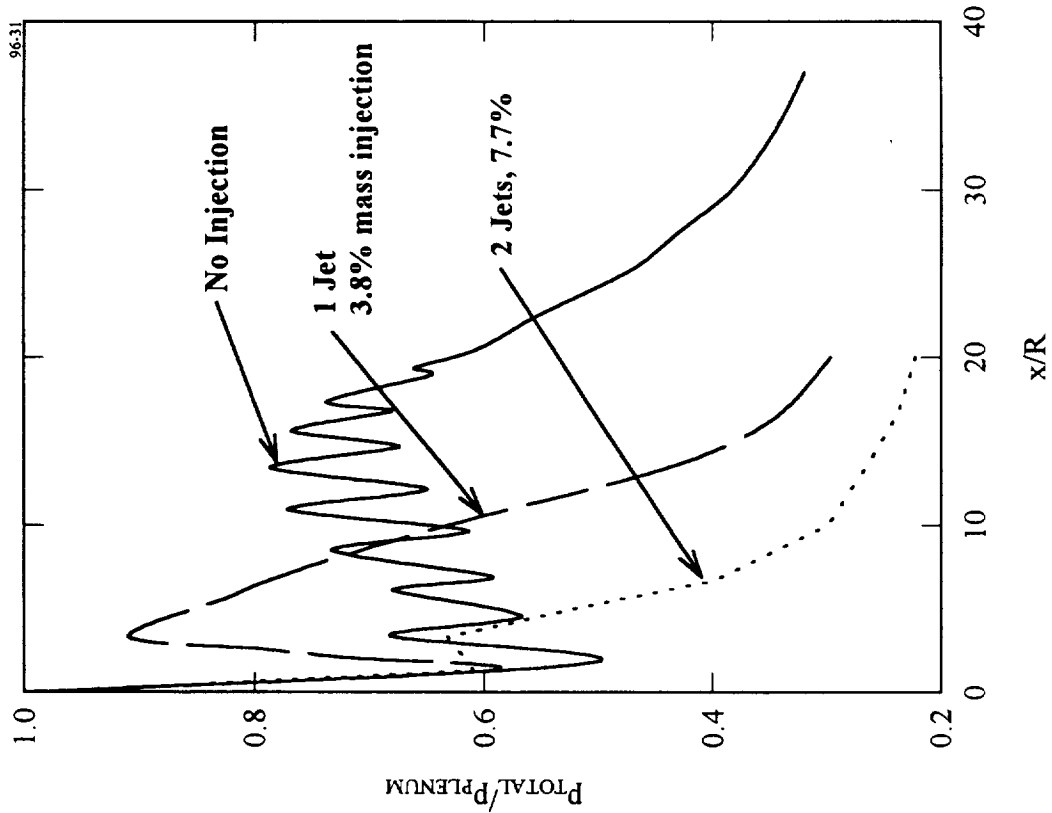
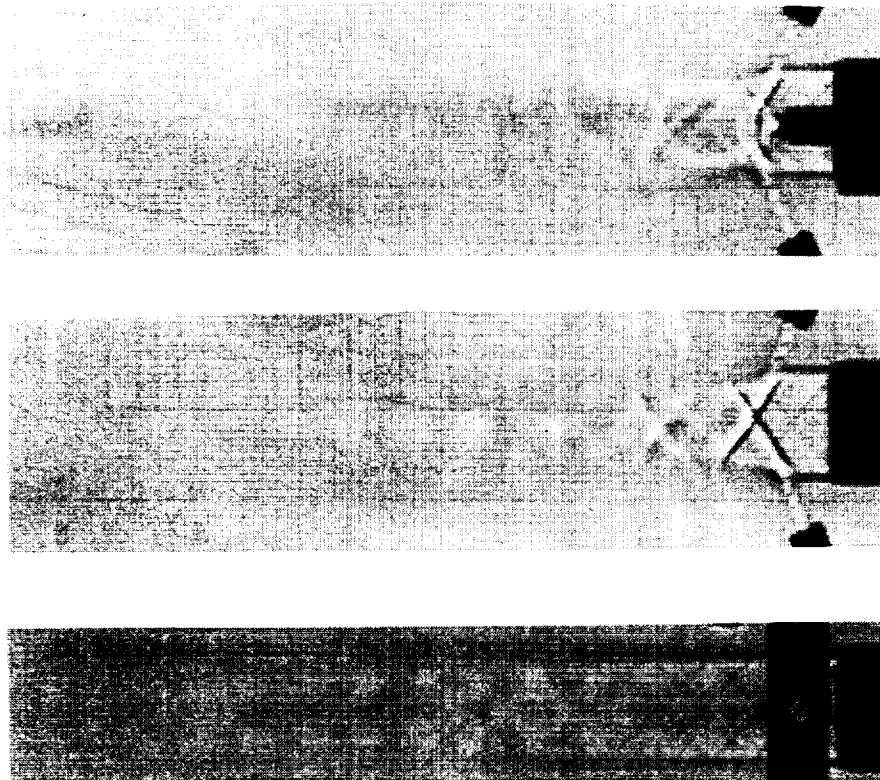
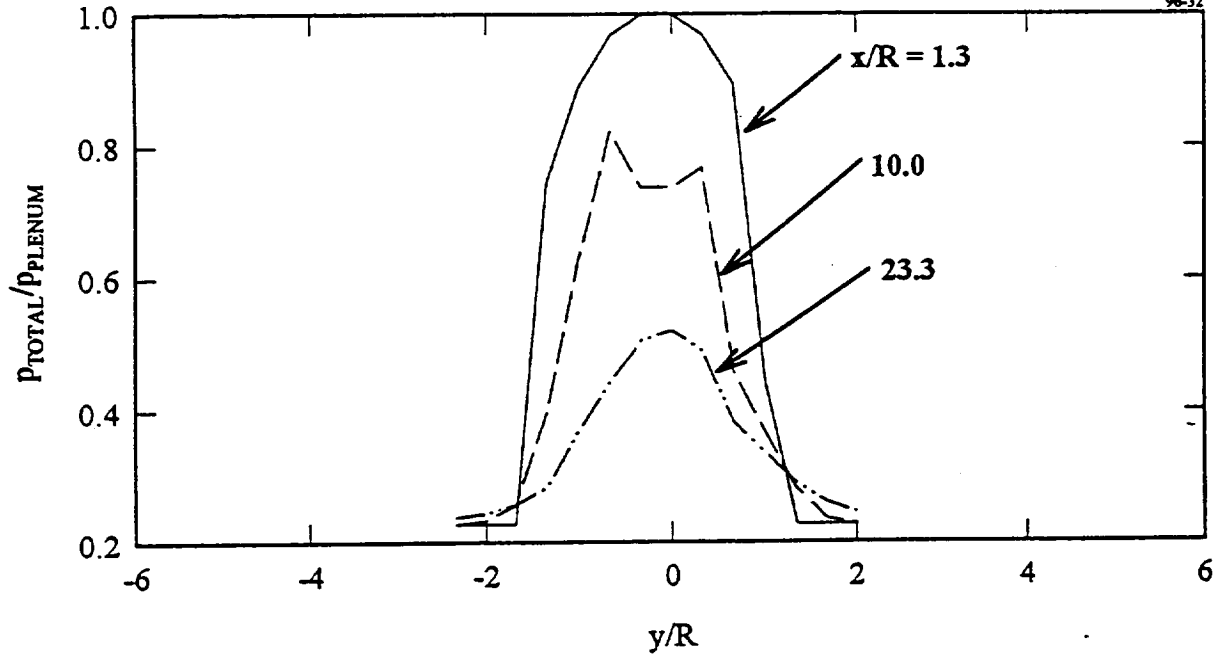

Fig. 4 Effect of Number of Secondary Jets on Centerline Pressure of an Underexpanded Jet
 $y = z = 0$
 Main Jet NPR = 4.5
 2 auxiliary jets with NPR = 4.1



a. (No jets)
 b. (2 jets)
 2.8% mass flow
 c. (4 jets)
 5.6% mass flow

Fig. 3 Shadowgraphs of Interaction of an Ideally Expanded Jet Flow with Auxiliary Jets at 30° from Radial Orientation
 Main Jet NPR = 3.24



a. No Injection

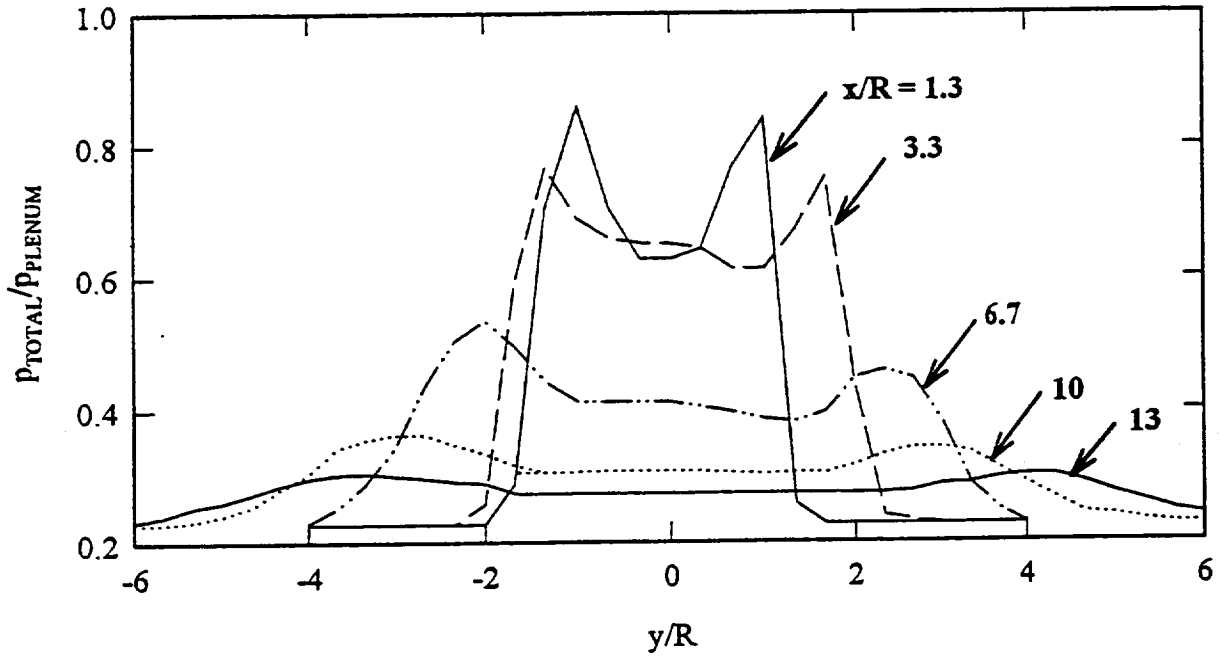

b. 2 Auxiliary Jets, NPR = 4.1
Mass Injection = 7.7%

Fig. 5 Effect of Two Secondary Jets on Pressure Profiles of an Underexpanded Jet
 $z = 0$
Main Jet NPR = 4.5

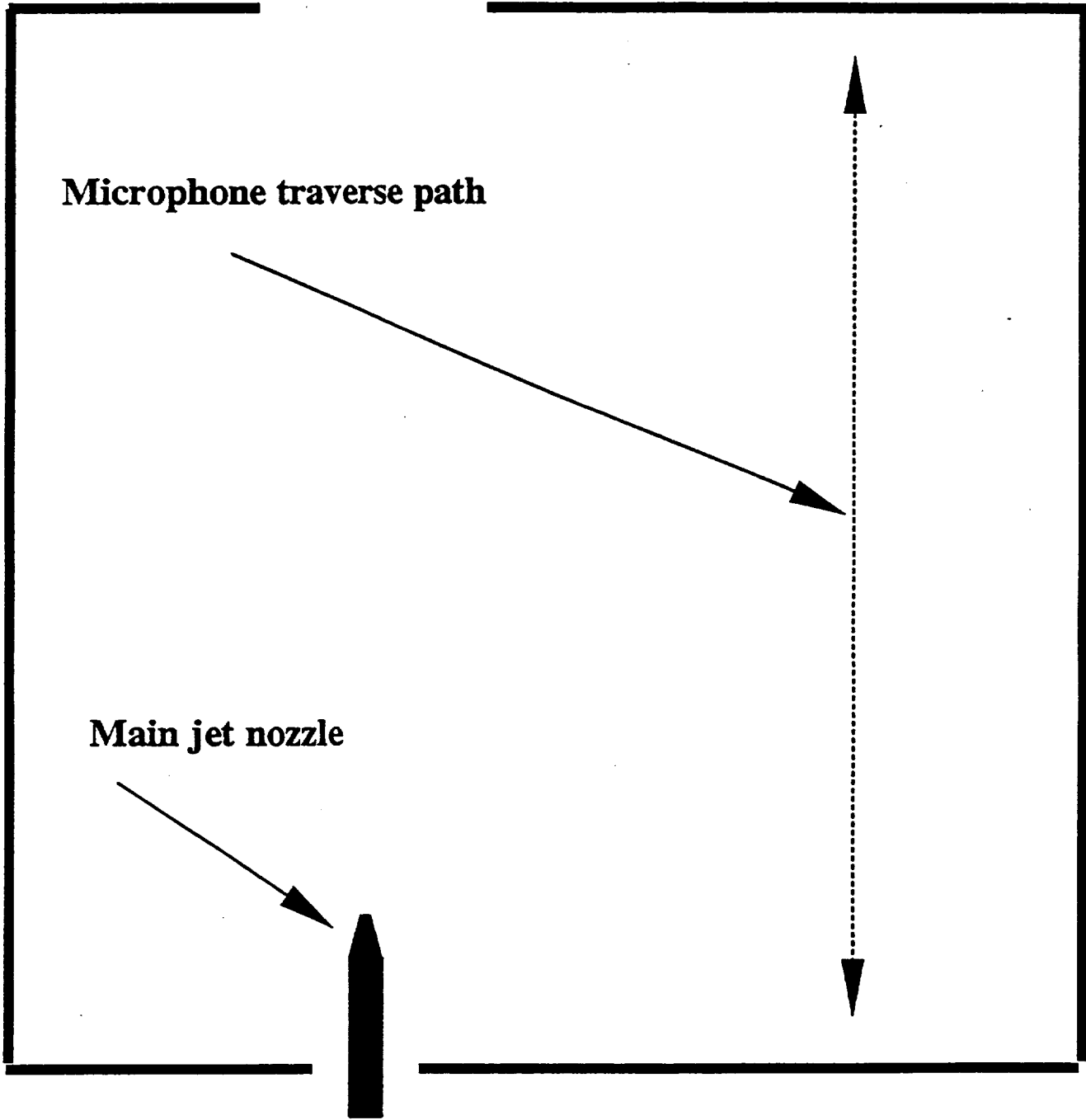

Fig. 6 Anechoic Chamber

96-34

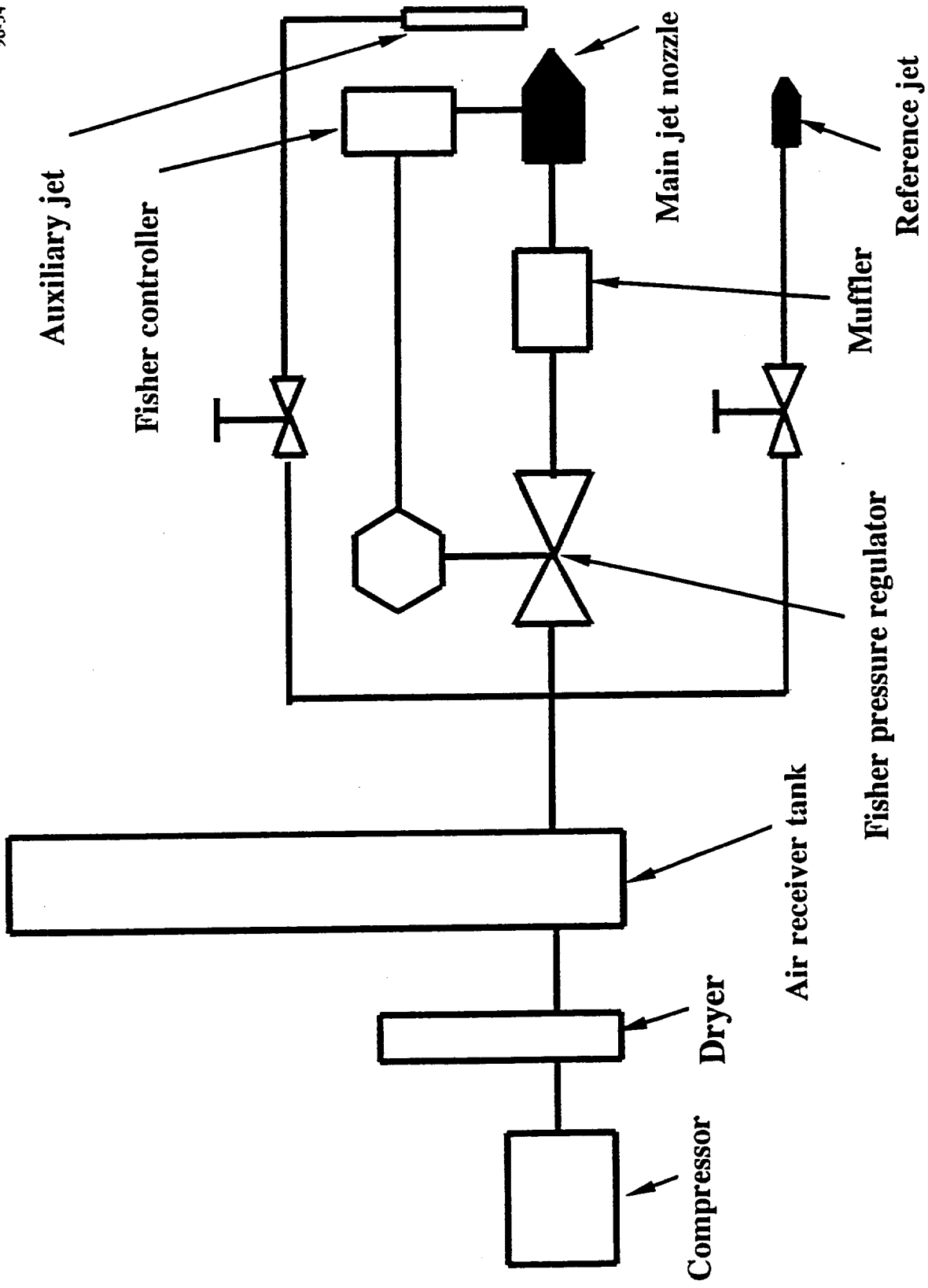

Fig. 7 Schematic of Air Flow System

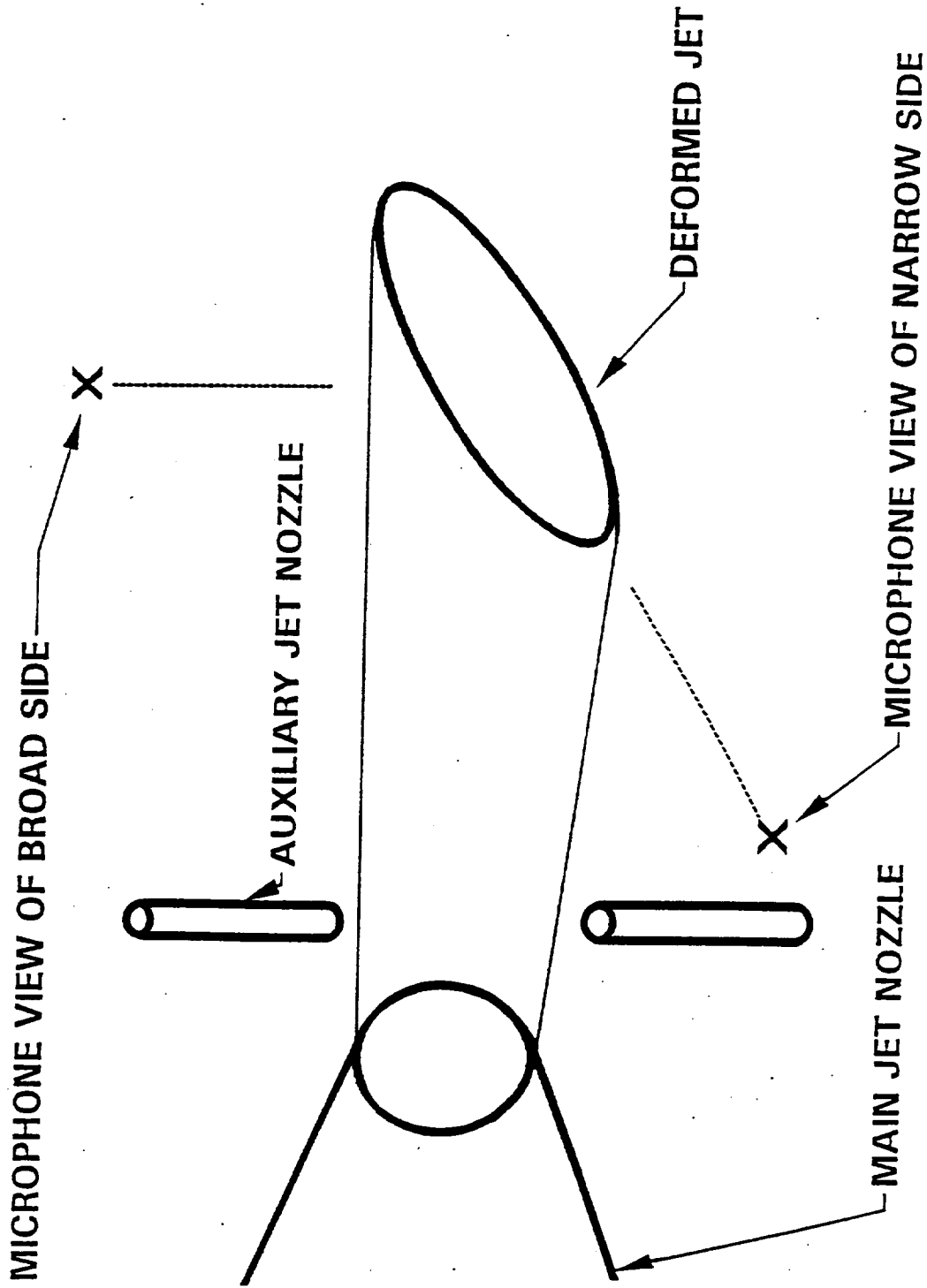
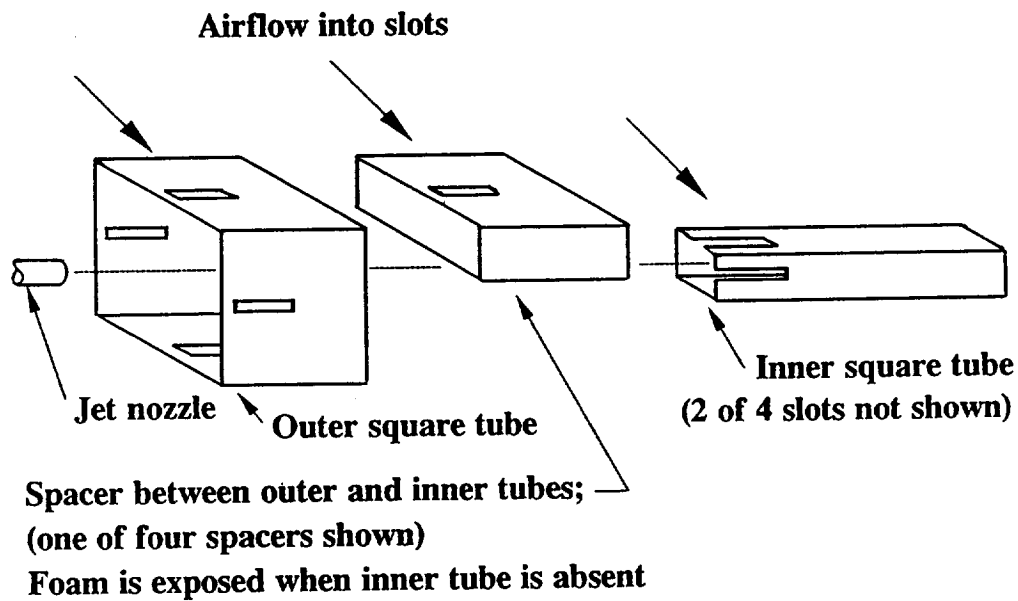
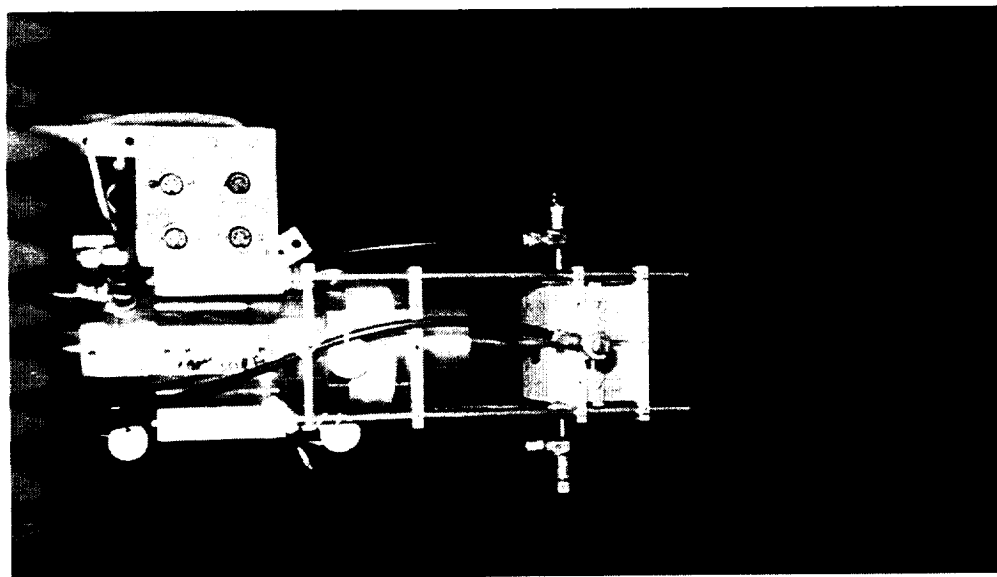

Fig. 8 Microphone Orientation



a. Assembly Sketch of Ejector



b. View of Plenum, Main Jet, Ejector, Auxiliary Jets

Fig. 9 Experimental Hardware

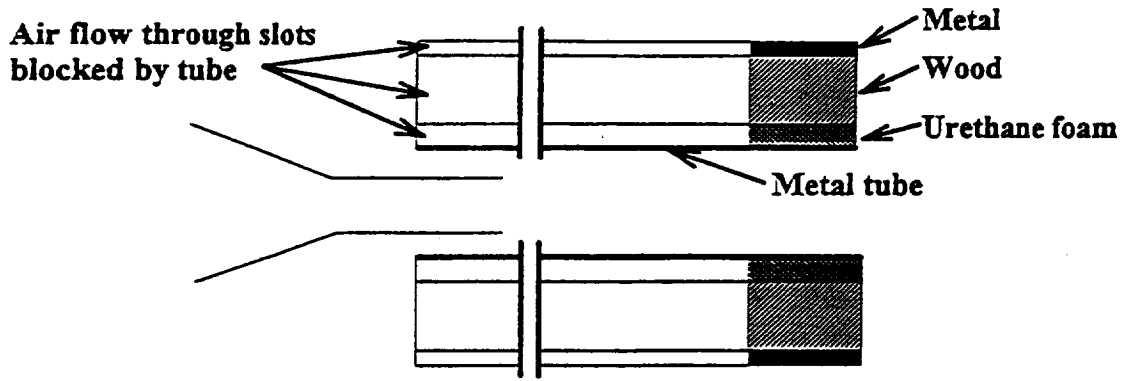

a. No flow through slots

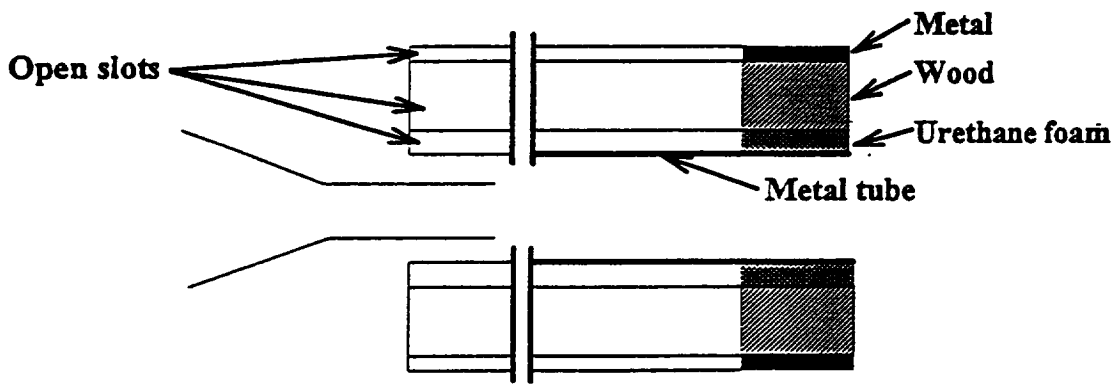

b. Flow through upstream slots

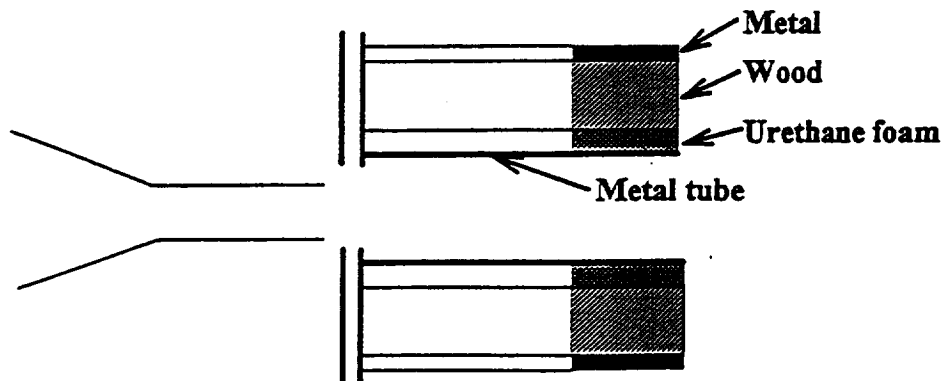

c. Downstream ejector

Fig. 10 Various Configurations for Ejector Support Structure

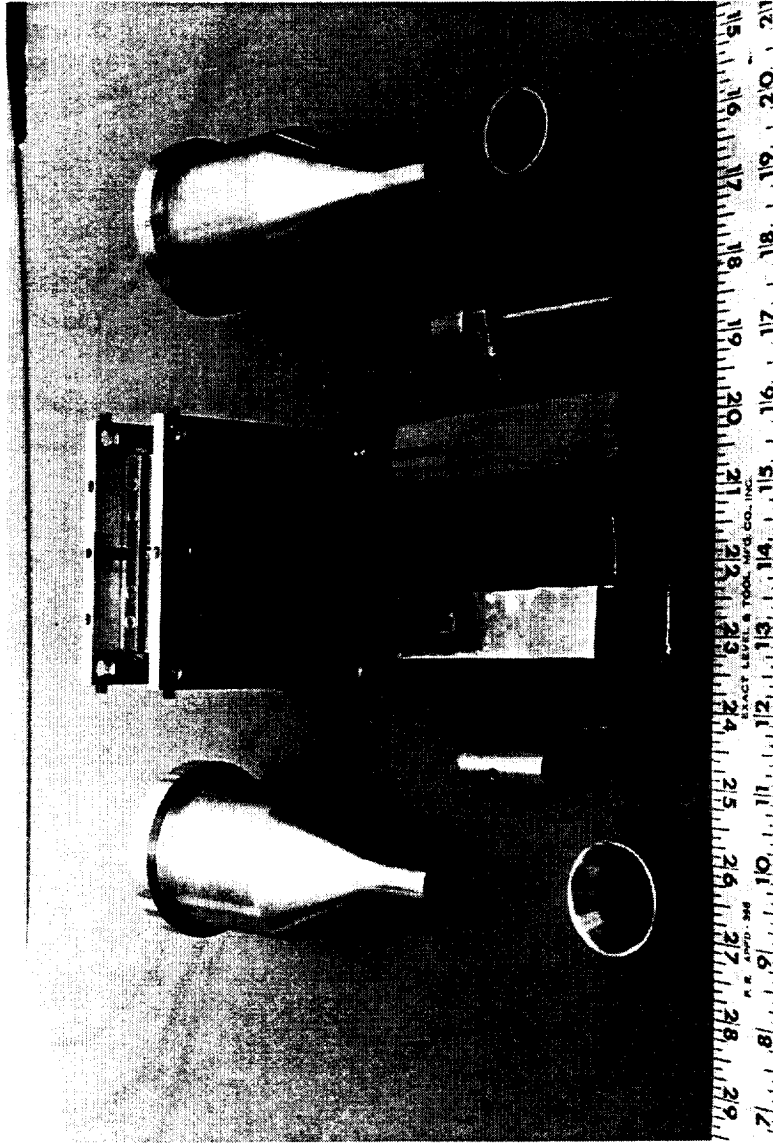

Fig. 11 Various Components of Experimental System

Top row, from left to right: converging nozzle, ejector support structure, converging-diverging nozzle

Bottom row, from left to right: shaped inlet, coaxial tube, square hardwalled ejector with slots, wire mesh screen, auxiliary jet injector, round hard walled ejector with slots

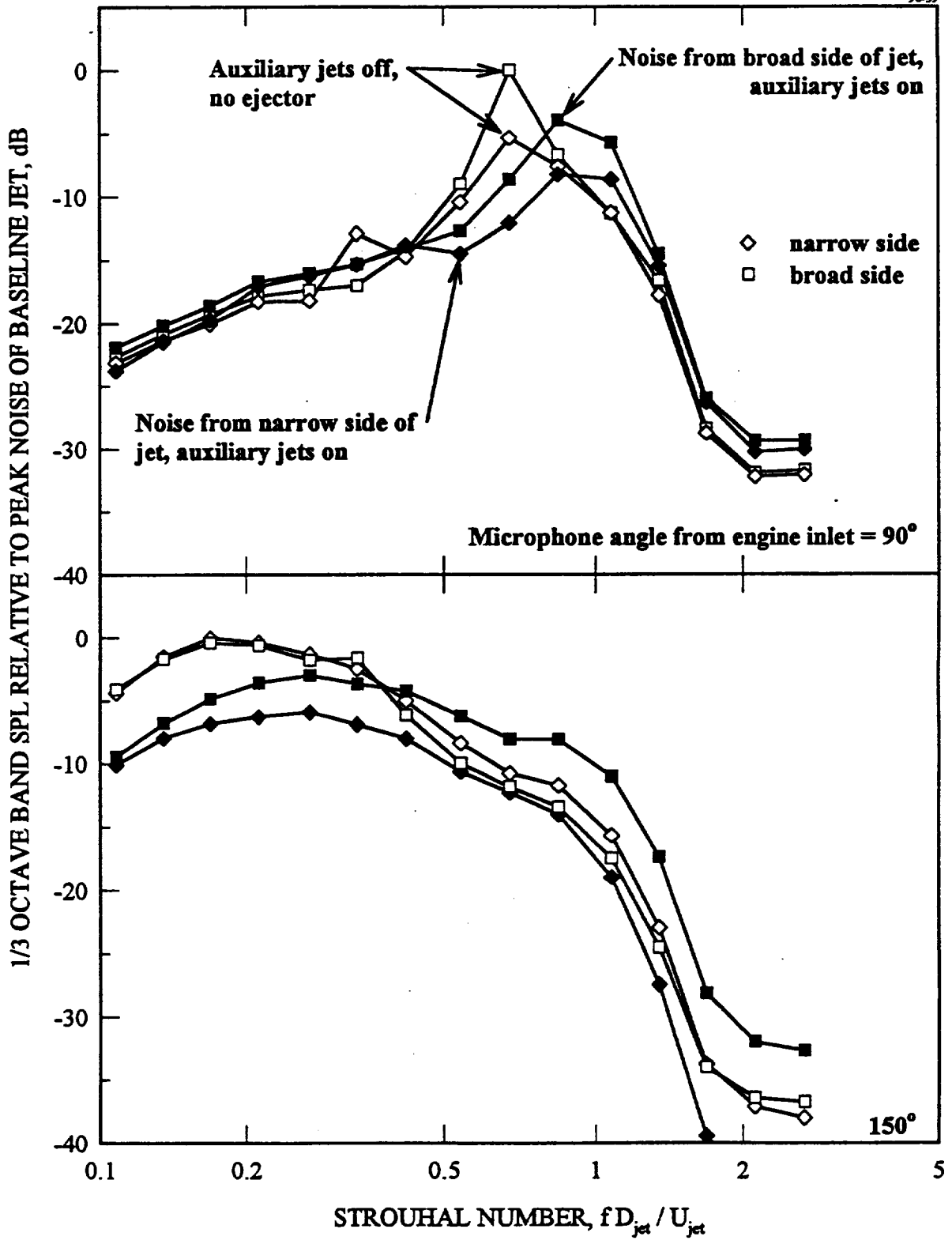

Fig. 12 Effect of Auxiliary Jet Orientation Without an Ejector
 Main Jet NPR = 3.72
 2 auxiliary jets with NPR = 2.37
 Auxiliary jet mass flow = 6.2% of main jet

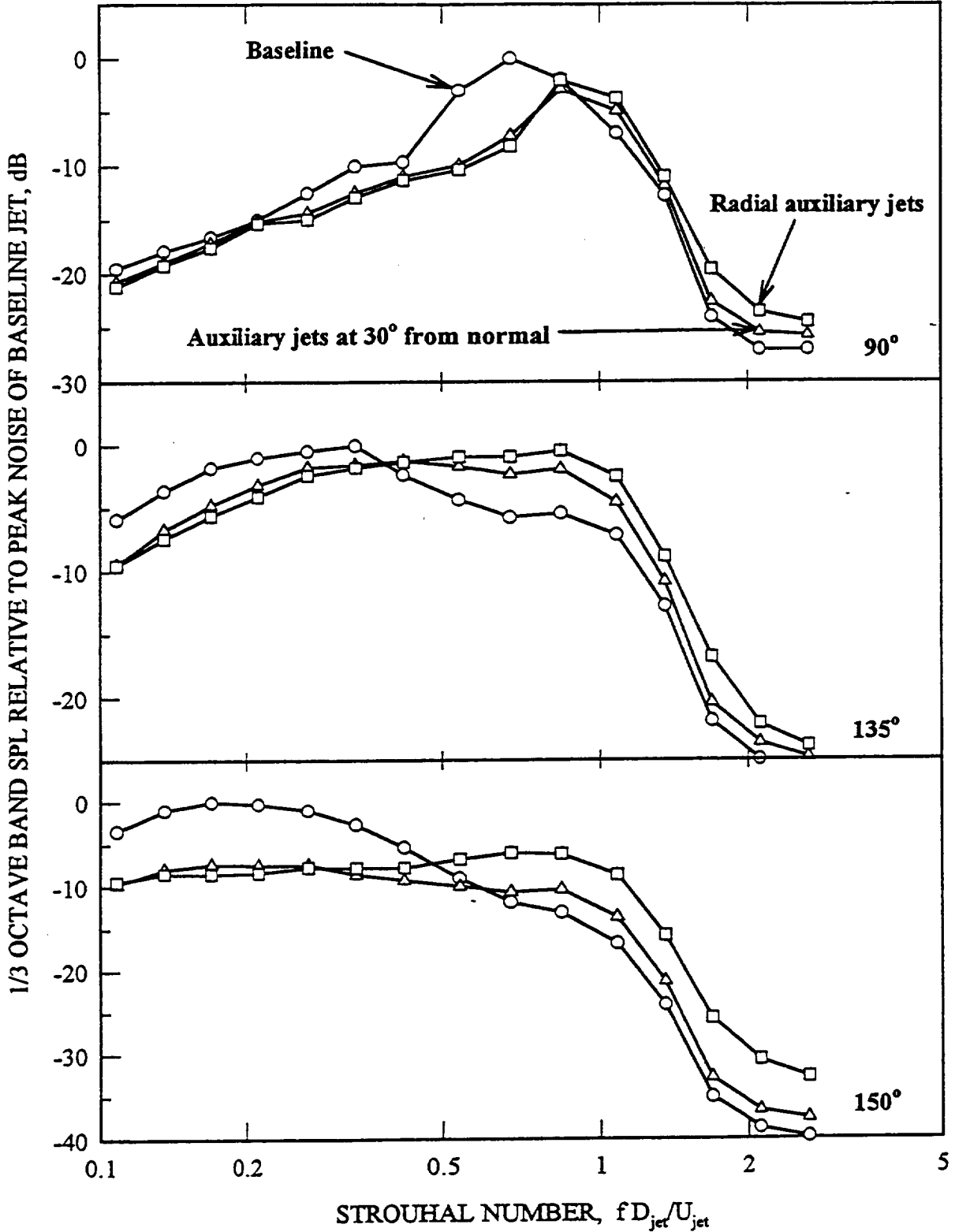

Fig. 13 Effect of Auxiliary Jet Angle without an Ejector
 Main jet NPR = 3.72
 4 auxiliary jets with NPR = 3.72
 Auxiliary jet mass flow = 5.6% of main jet

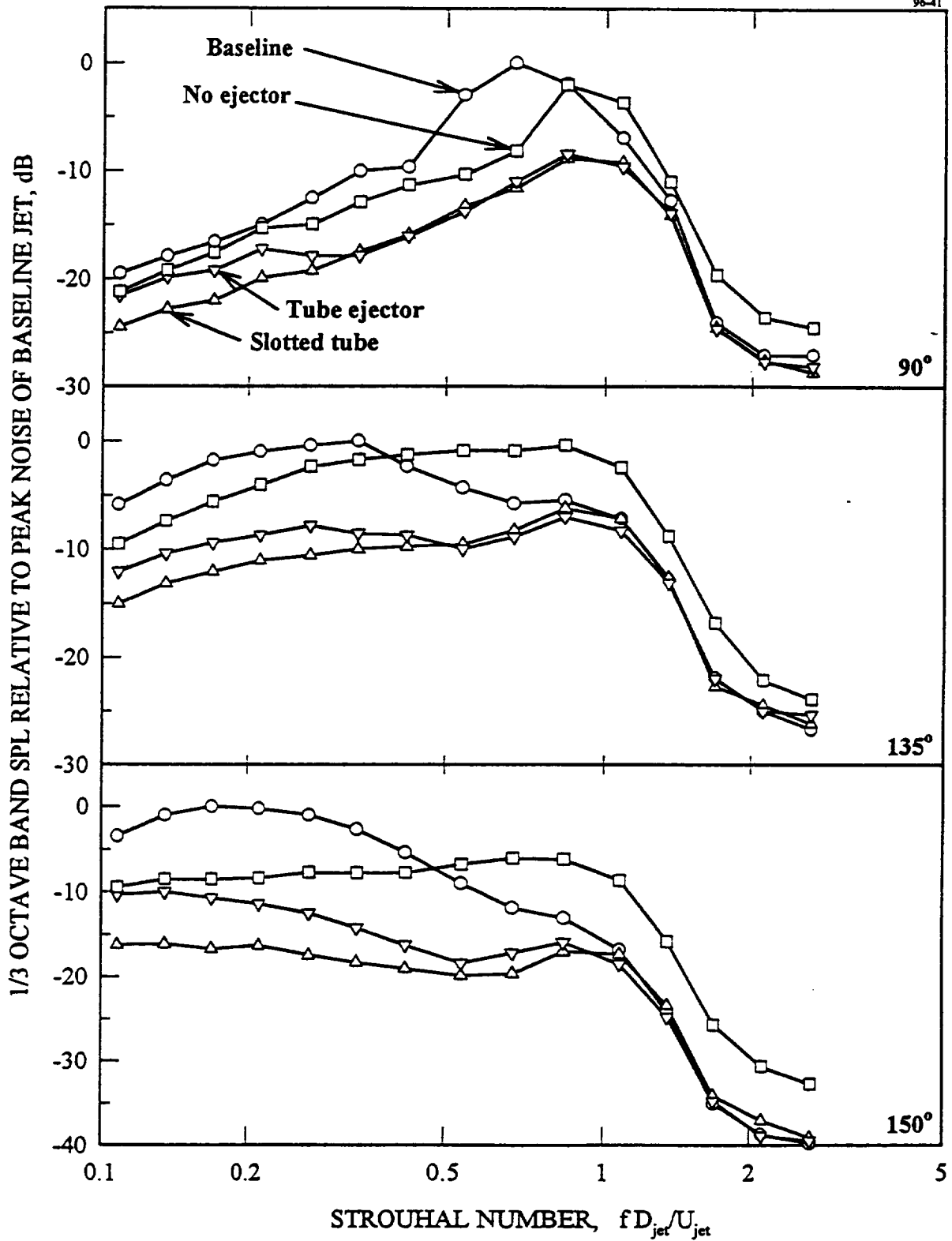

Fig. 14 Range of Effects with and without a Hard Walled Ejector
 Main jet NPR = 3.72
 4 auxiliary jets with NPR = 3.72
 Auxiliary jet mass flow = 5.6% of main jet

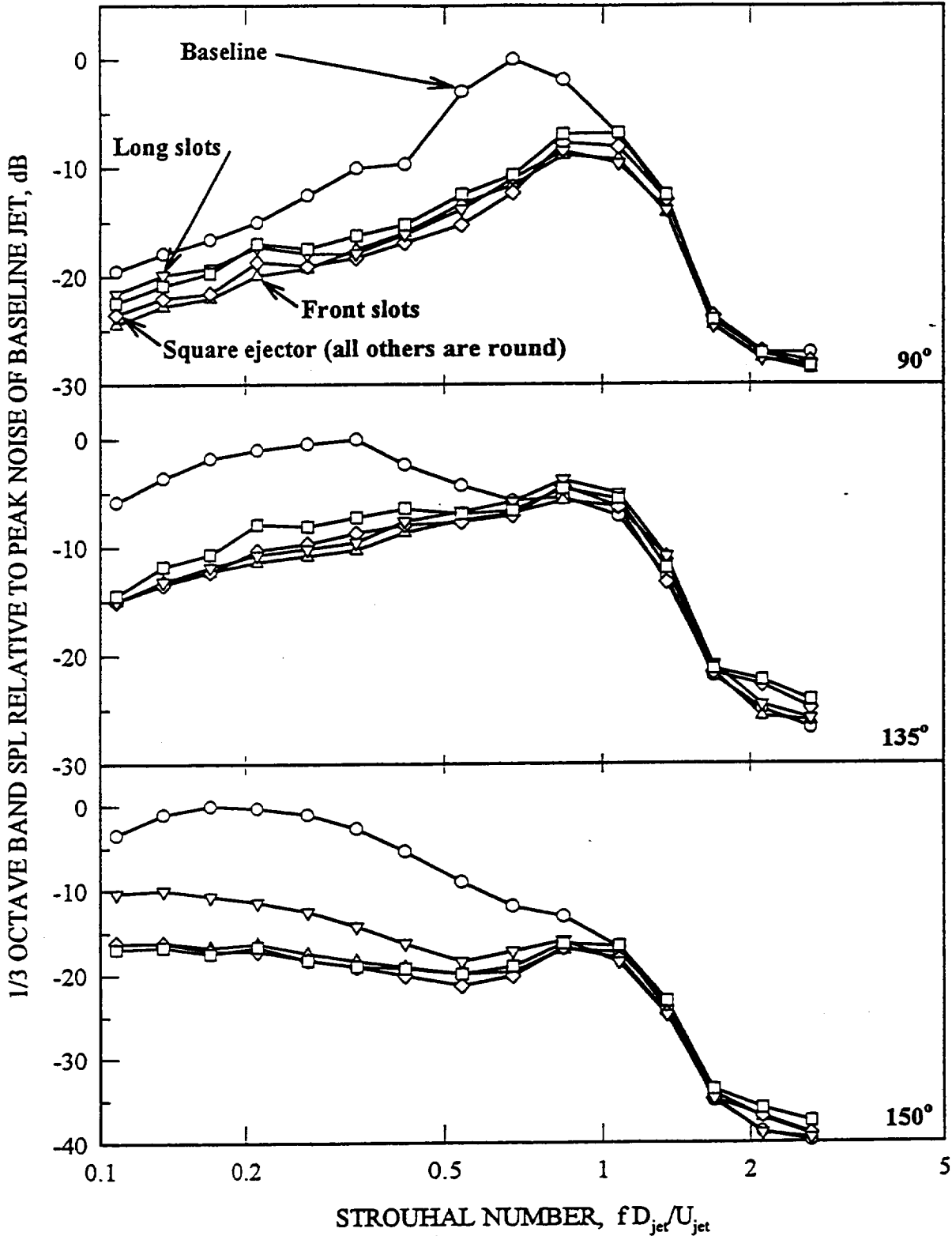

Fig. 15 Effect of Different Types of Ejector Slots
 Main jet NPR = 3.72
 4 auxiliary jets with NPR = 3.72
 Auxiliary jet mass flow = 5.6% of main jet

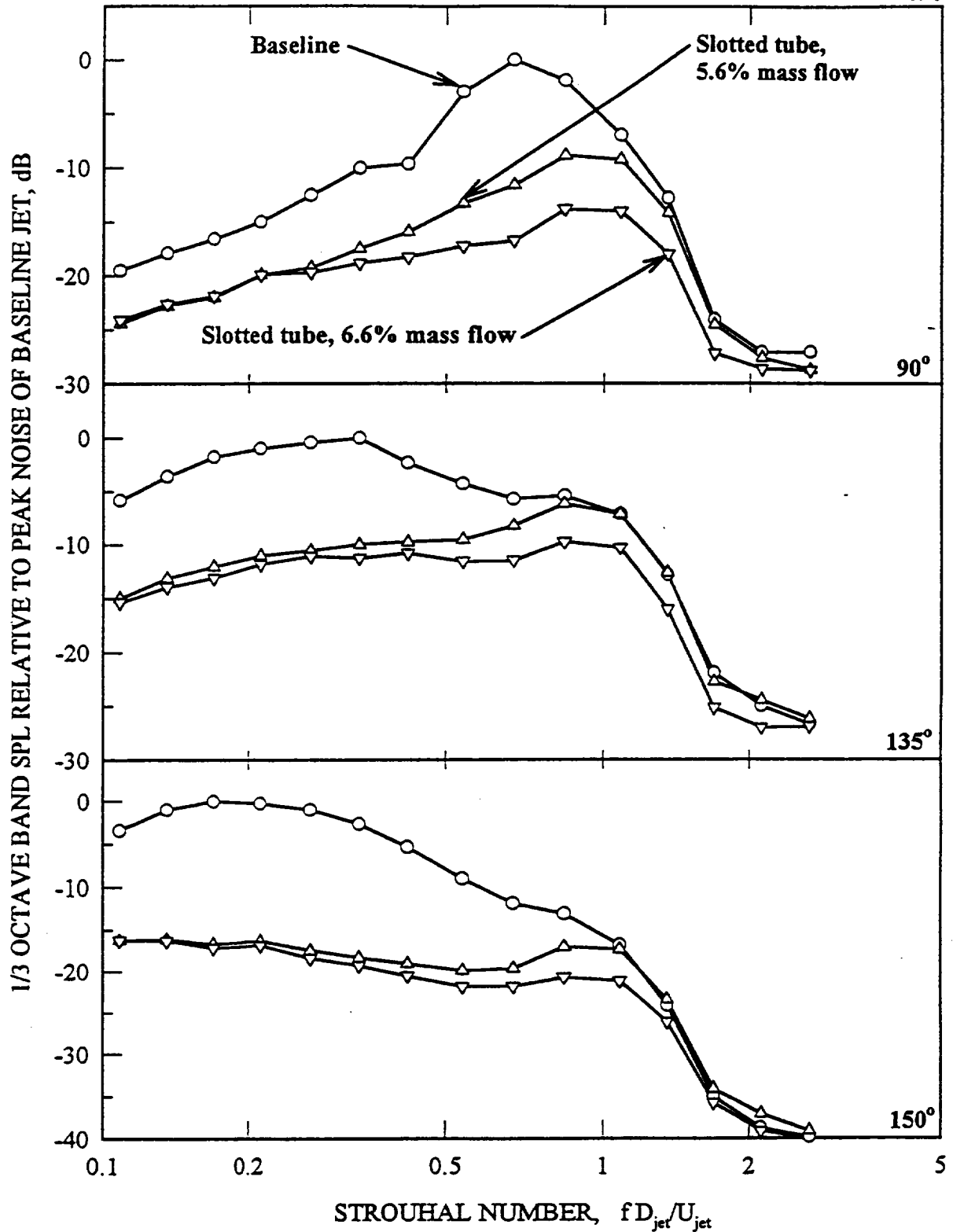

Fig. 16 Effect of Auxiliary Jet Mass Flow on Slotted Tube Ejector
 Main jet NPR = 3.72
 4 auxiliary jets

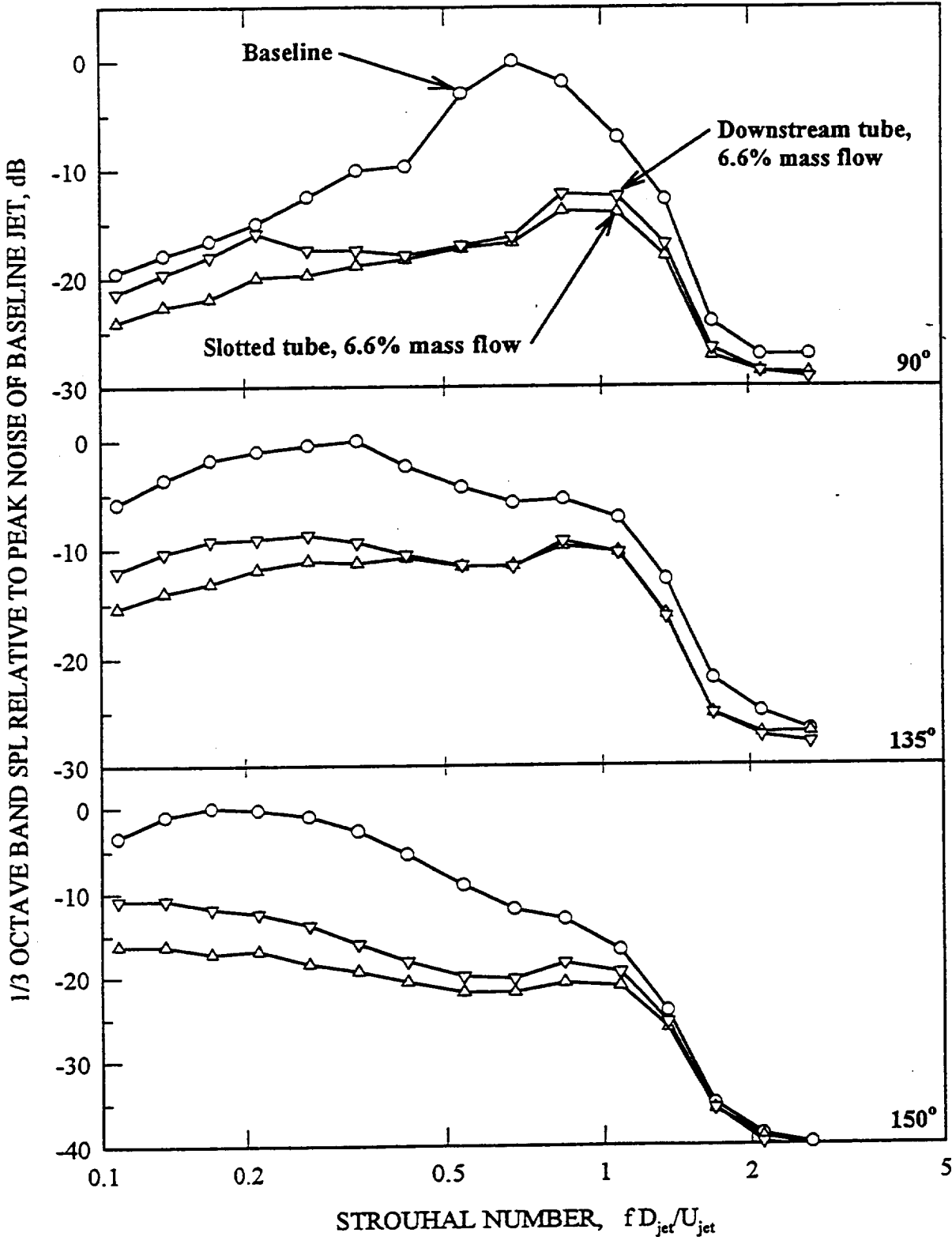

Fig. 17 Effect of Tube Ejector Placement
 Main jet NPR = 3.72
 4 auxiliary jets

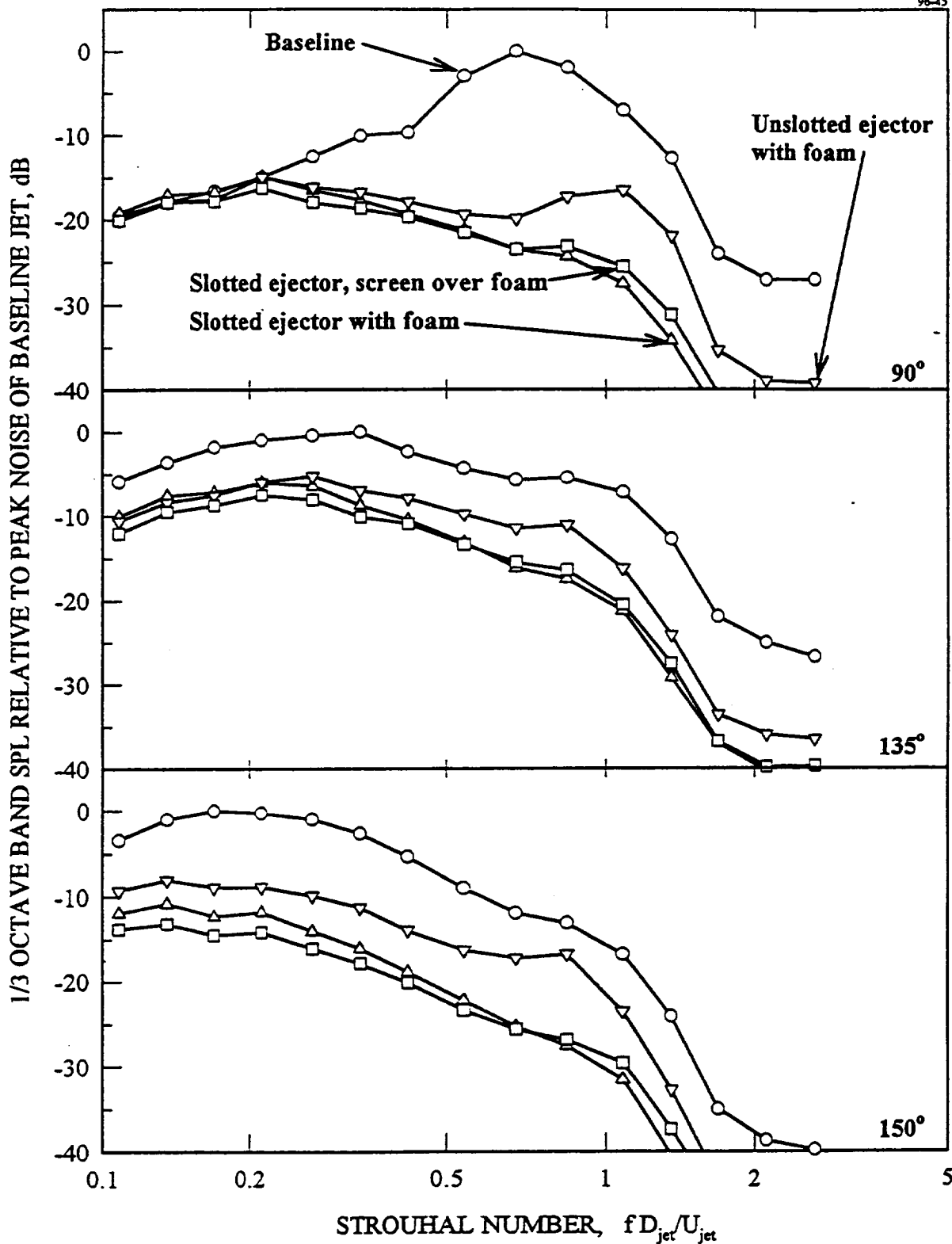

Fig. 18 Effect of Lining Details for Square Ejectors
 Main jet NPR = 3.72
 4 auxiliary jets with NPR = 3.72
 Auxiliary jet mass flow = 5.6% of main jet

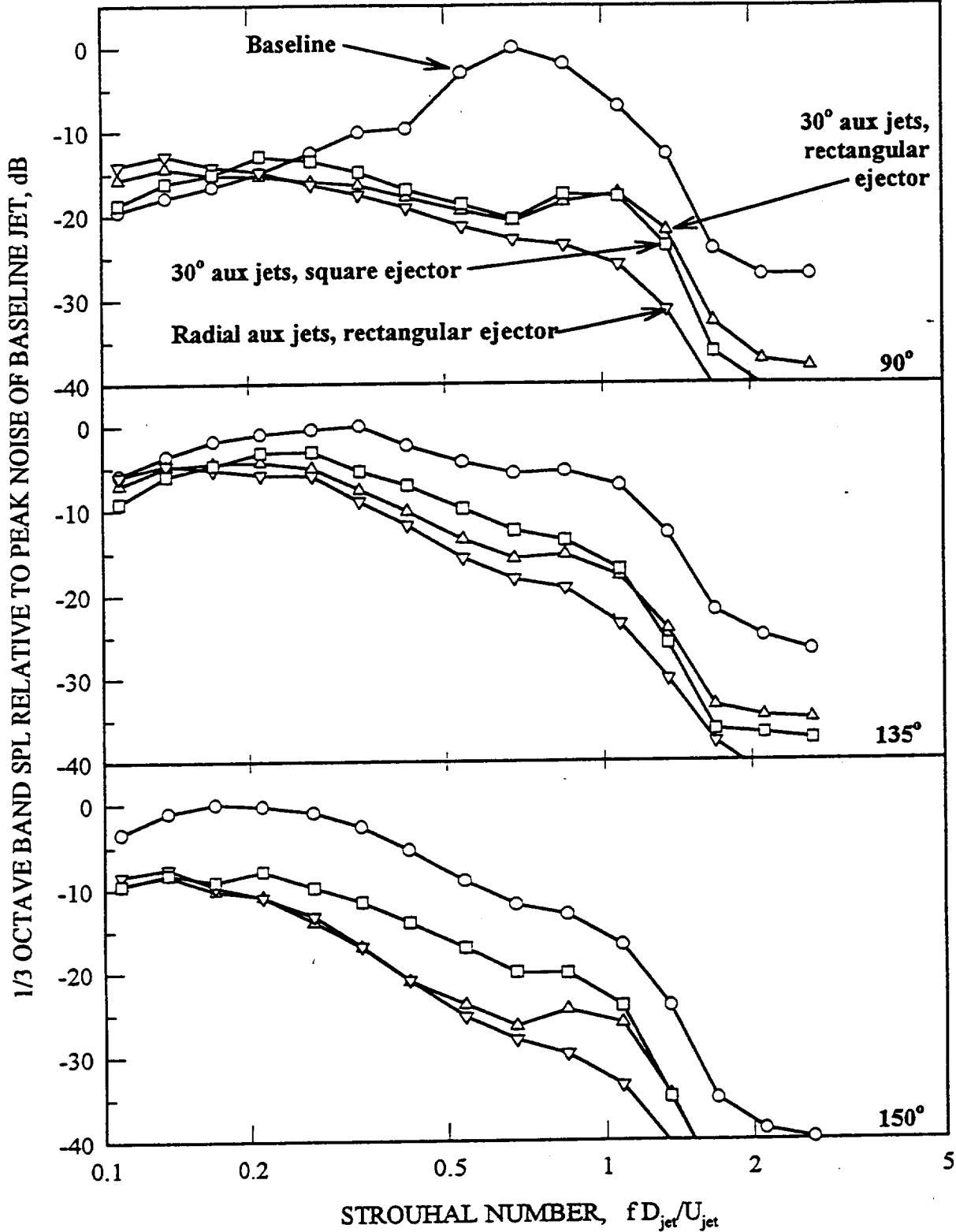

Fig. 19 Effect of Auxiliary Jet Angle with a Lined Ejector
 Main Jet NPR = 3.72
 4 auxiliary jets with NPR = 3.72
 Auxiliary jet mass flow = 5.6% of main jet

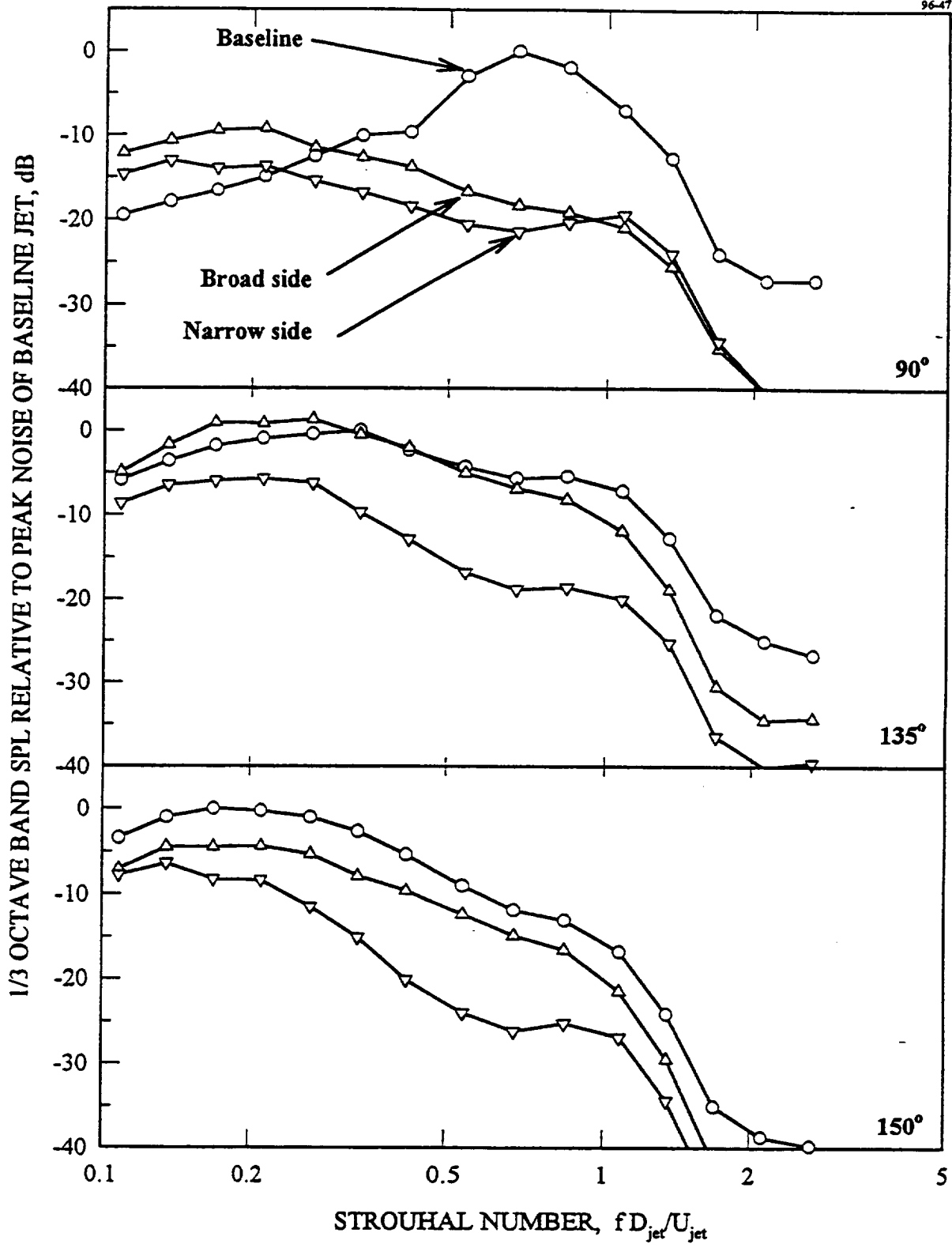

Fig. 20 Effect of Rectangular Ejector Orientation
 Main jet NPR = 3.72
 4 auxiliary jets with NPR = 1.69
 Auxiliary jet mass flow = 8.1% of main jet

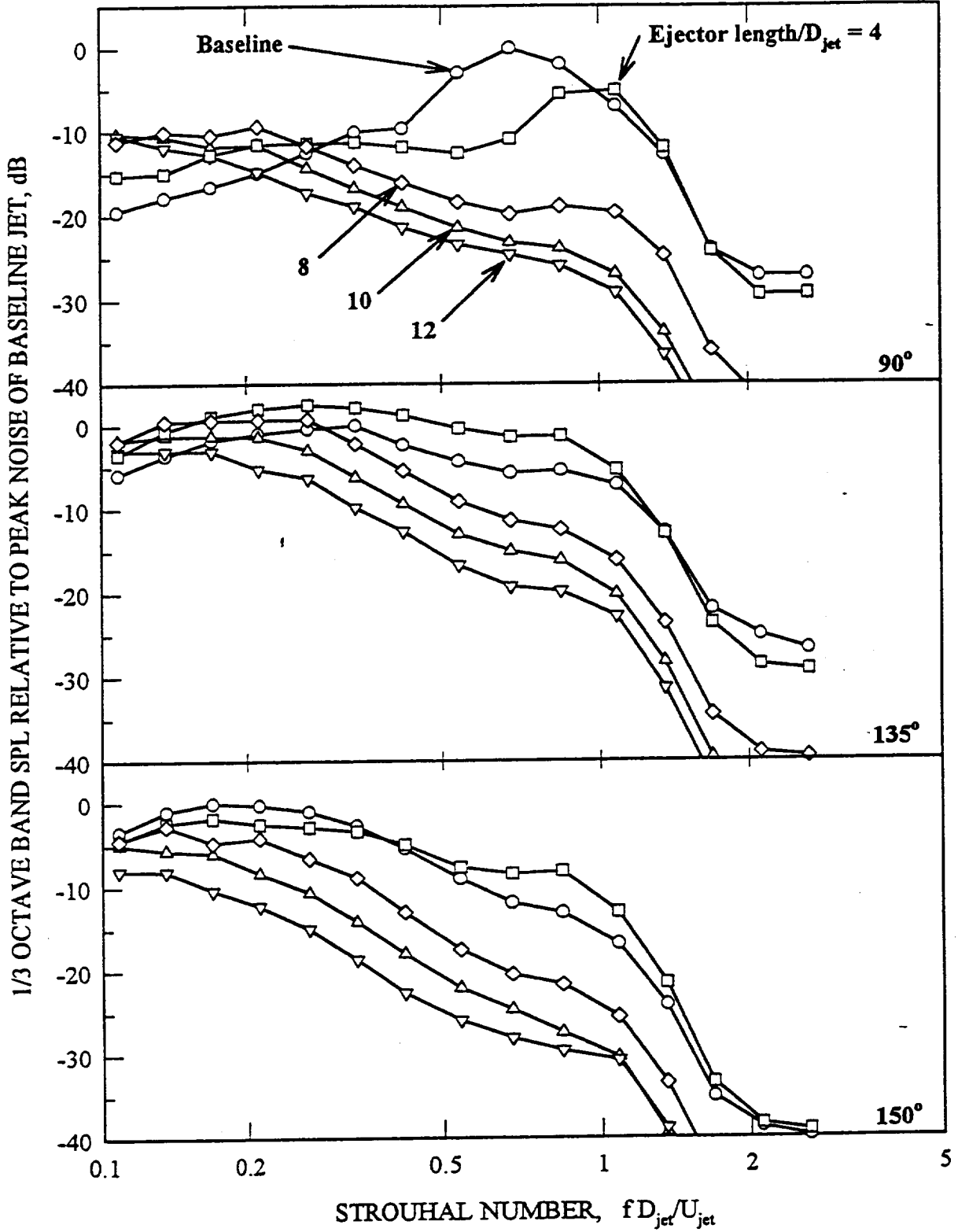

Fig. 21 Effect of Lined Rectangular Ejector Length
 Main Jet NPR = 3.72
 2 auxiliary jets with NPR = 2.14
 Auxiliary jet mass flow = 5.6% of main jet

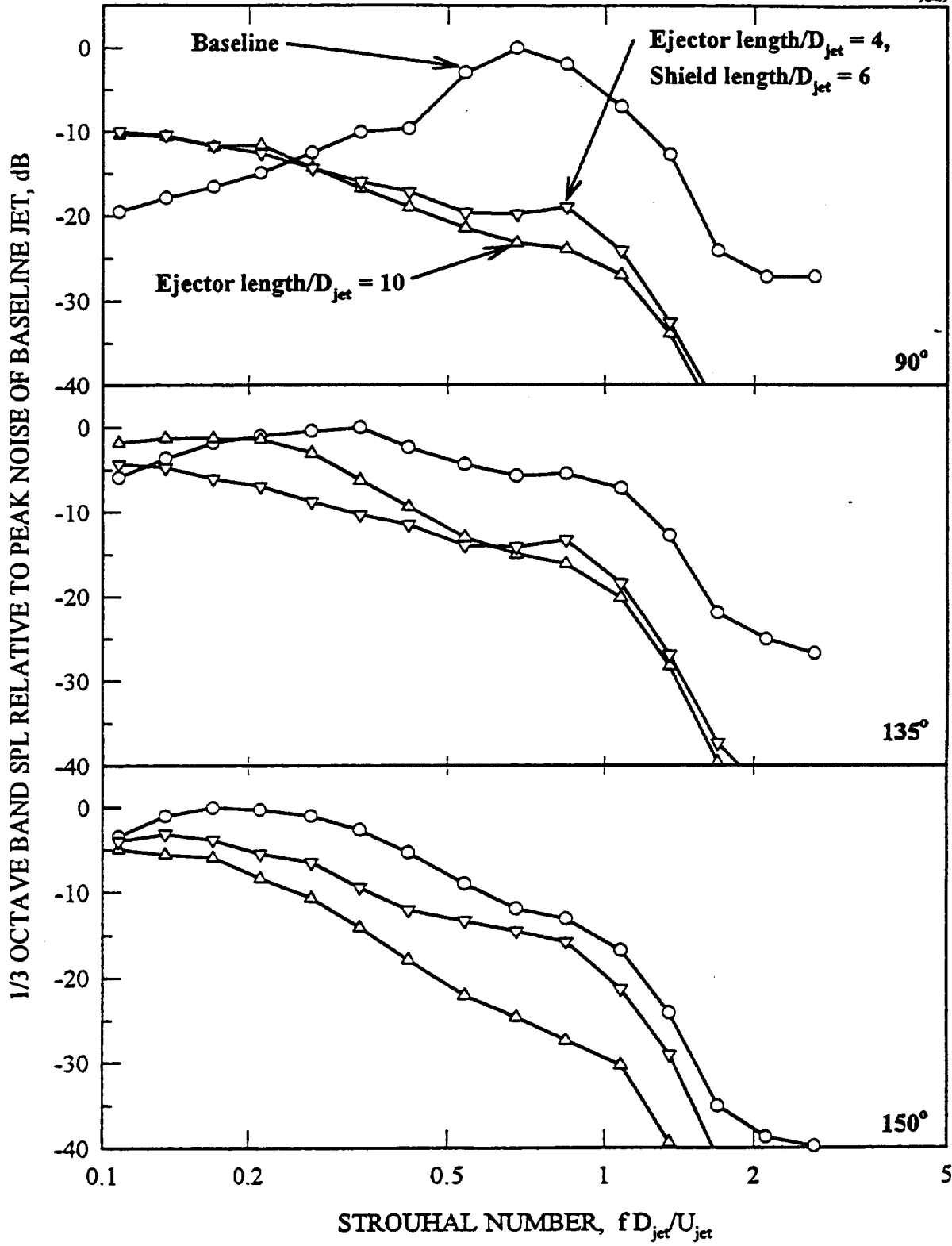

Fig. 22 Effect of Shield Added to an Ejector
 Main jet NPR = 3.72
 2 auxiliary jets with NPR = 2.14
 Auxiliary jet mass flow = 5.6% of main jet

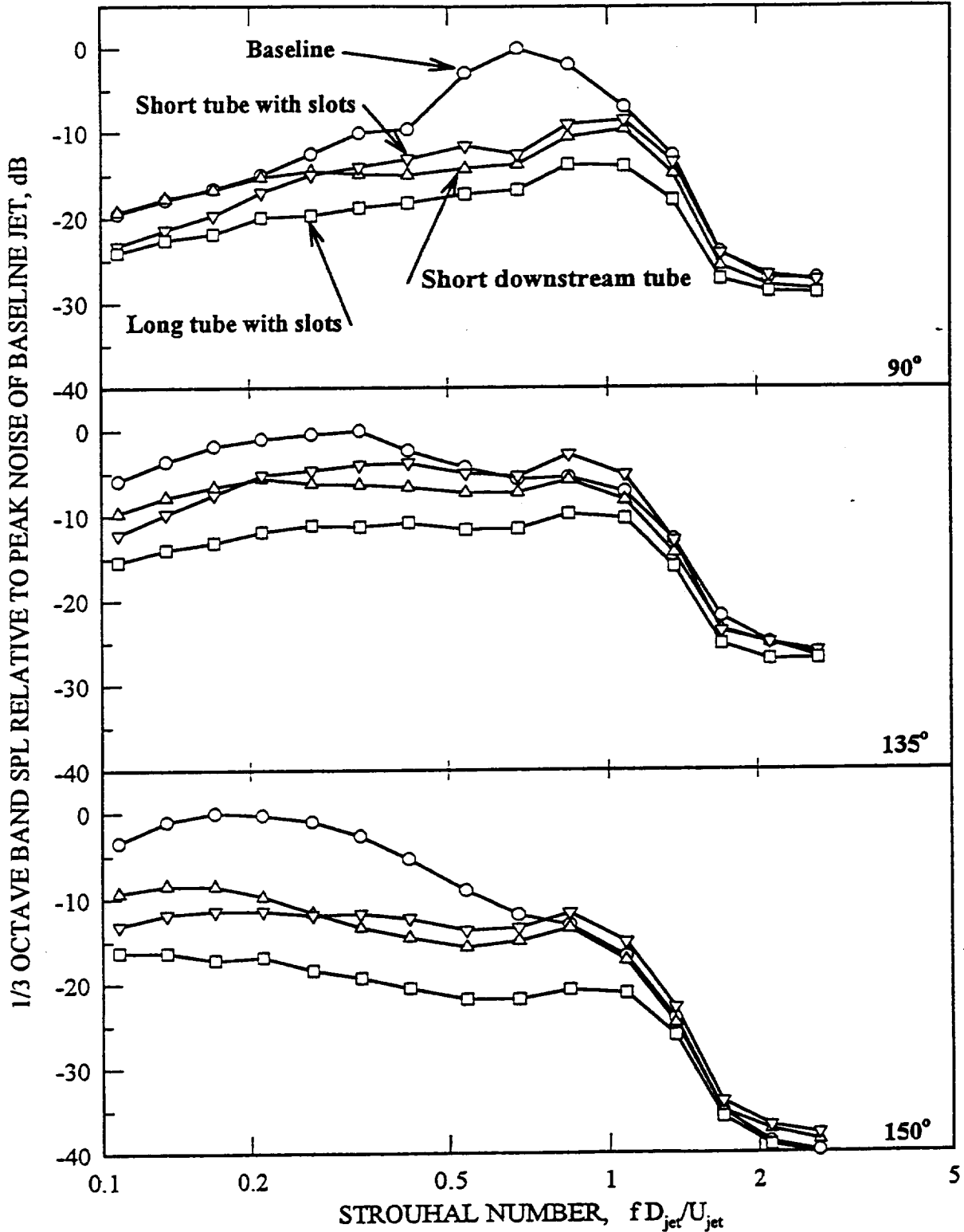

Fig. 23 Effect of Shortening a Hard Walled Ejector
 Ejector Length/ D_{jet} = 4

Main Jet NPR = 3.72, 4 auxiliary jets with NPR = 4.4
 Auxiliary jet mass flow = 6.6% of main jet

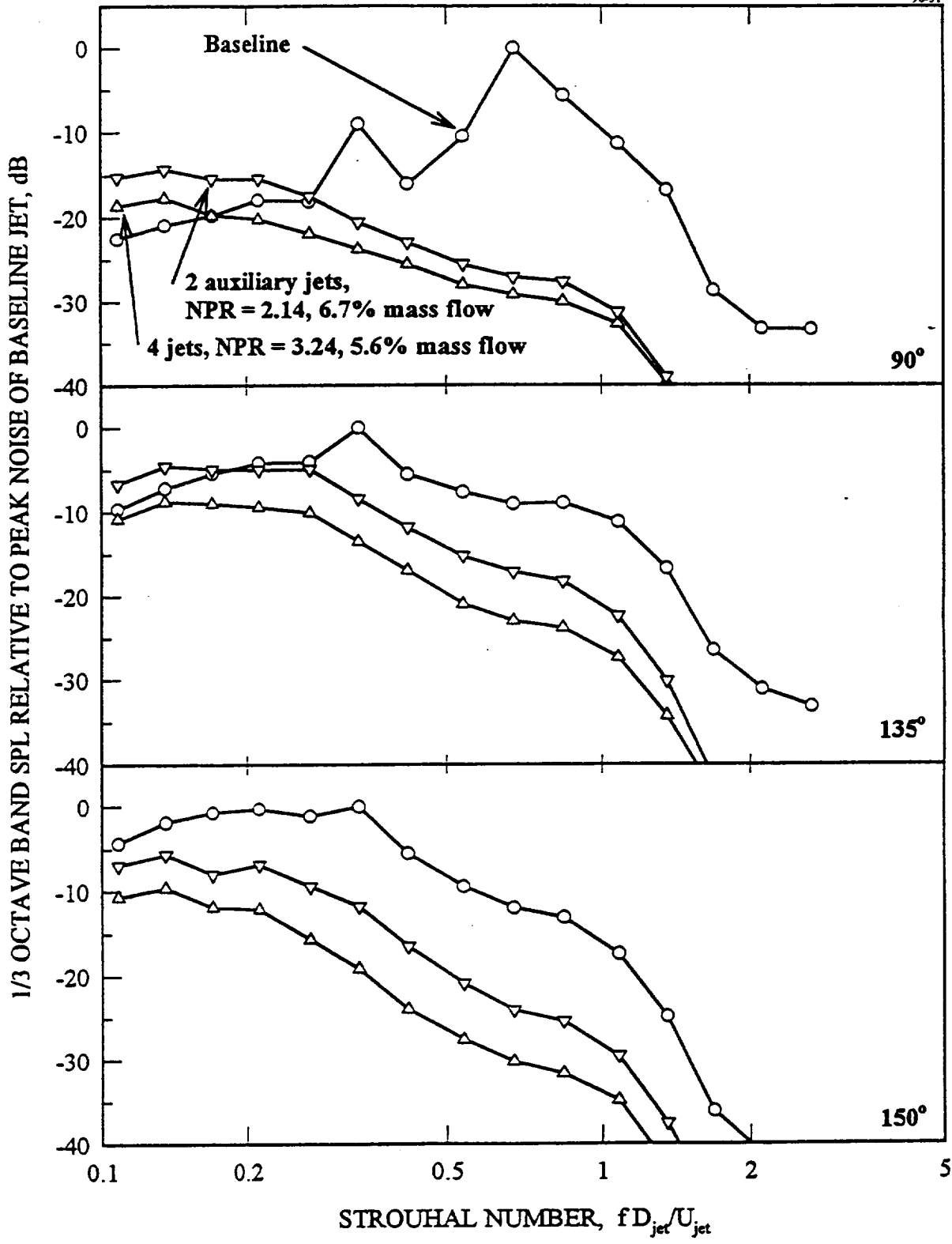

Fig. 24 Effect of Lined Ejector on Ideally Expanded Jet
Main jet NPR = 3.24

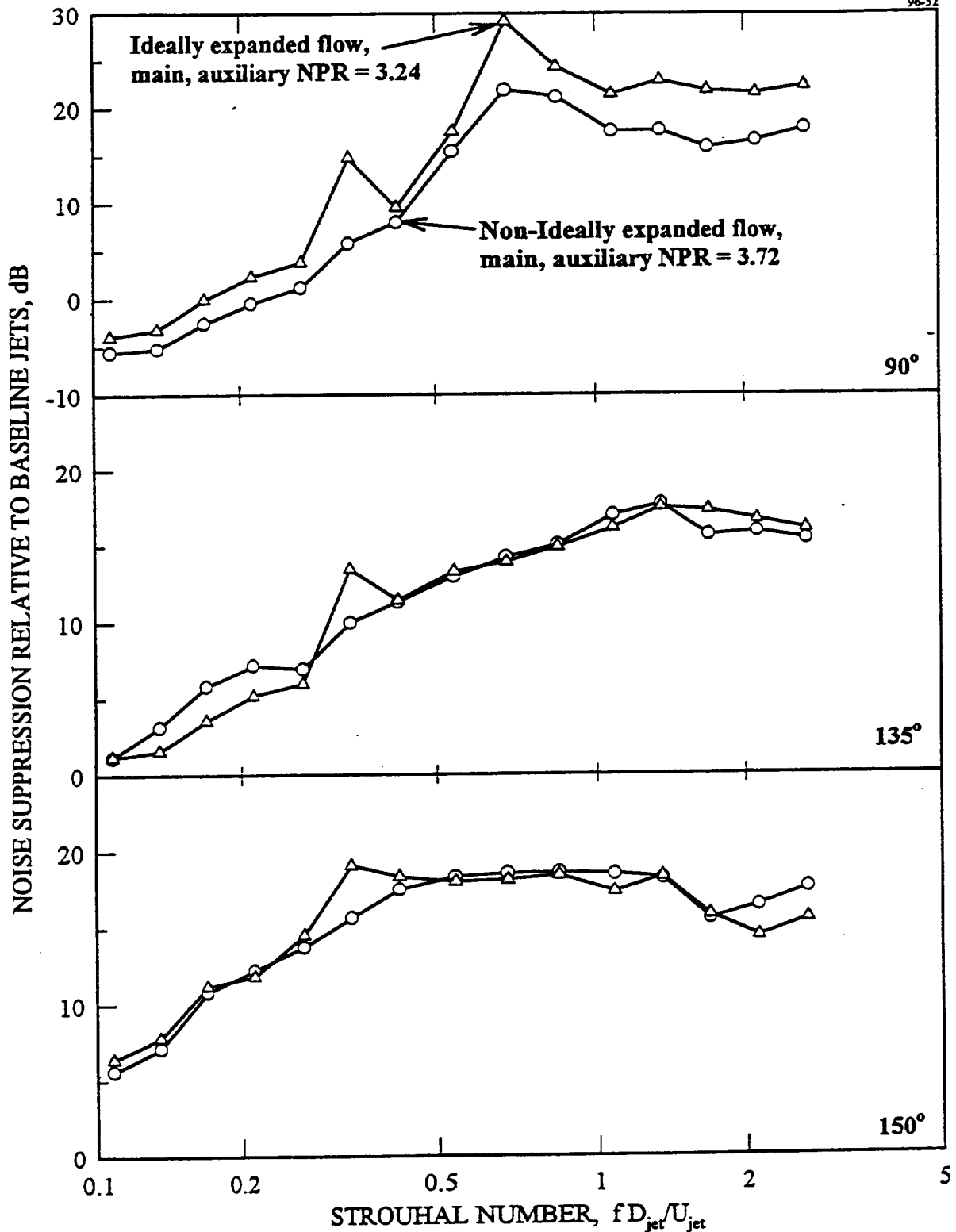
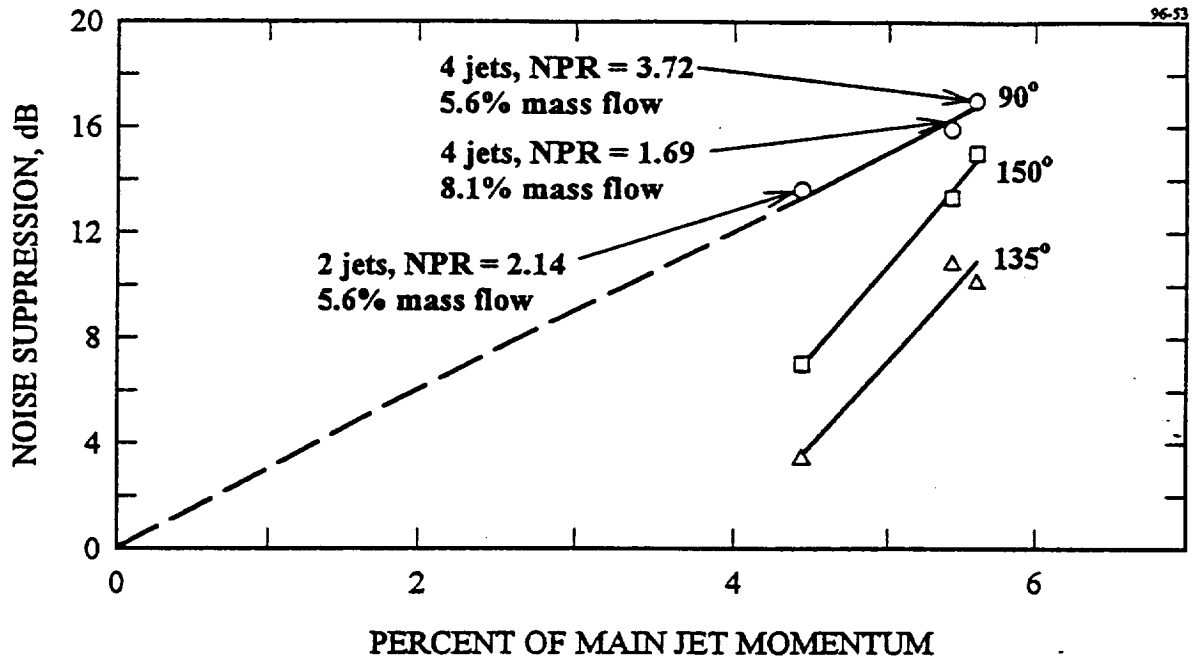

Fig. 25 Noise Suppression of a Lined Rectangular Ejector with Ideally and Non-Ideally Expanded Main Jets
 Baseline is a Non-Ideally Expanded Jet
 4 auxiliary jets
 Auxiliary jet mass flow = 5.6% of main jet



PERCENT OF MAIN JET MOMENTUM

Fig. 26 Noise Suppression vs. Percent Auxiliary Jet Momentum in Mid-Frequency Range
 Main Jet NPR = 3.72
 Lined Ejector Length/ D_{jet} = 8

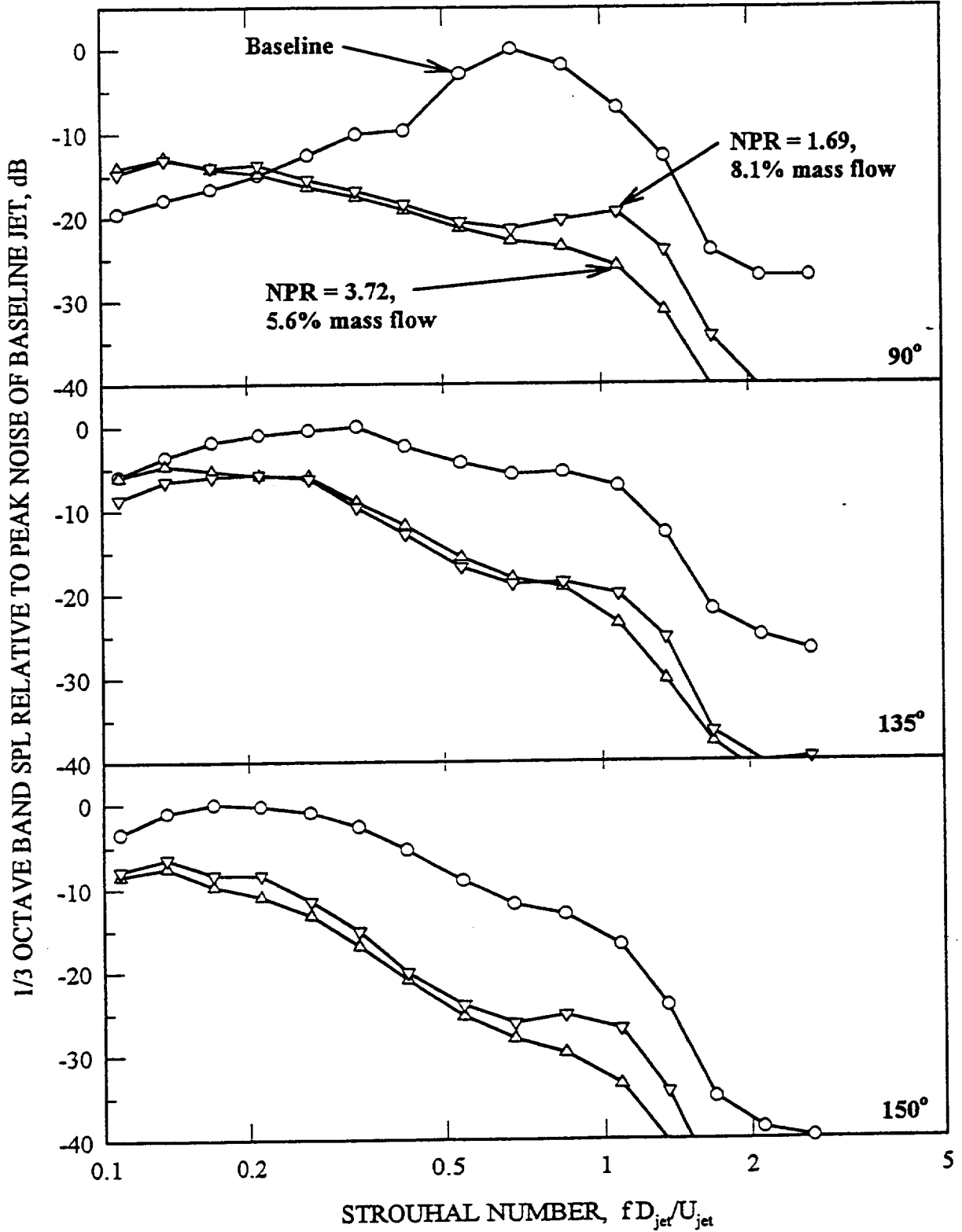

Fig. 27 Auxiliary Jets with the Same Momentum and Different NPR
 Main jet NPR = 3.72
 4 auxiliary jets

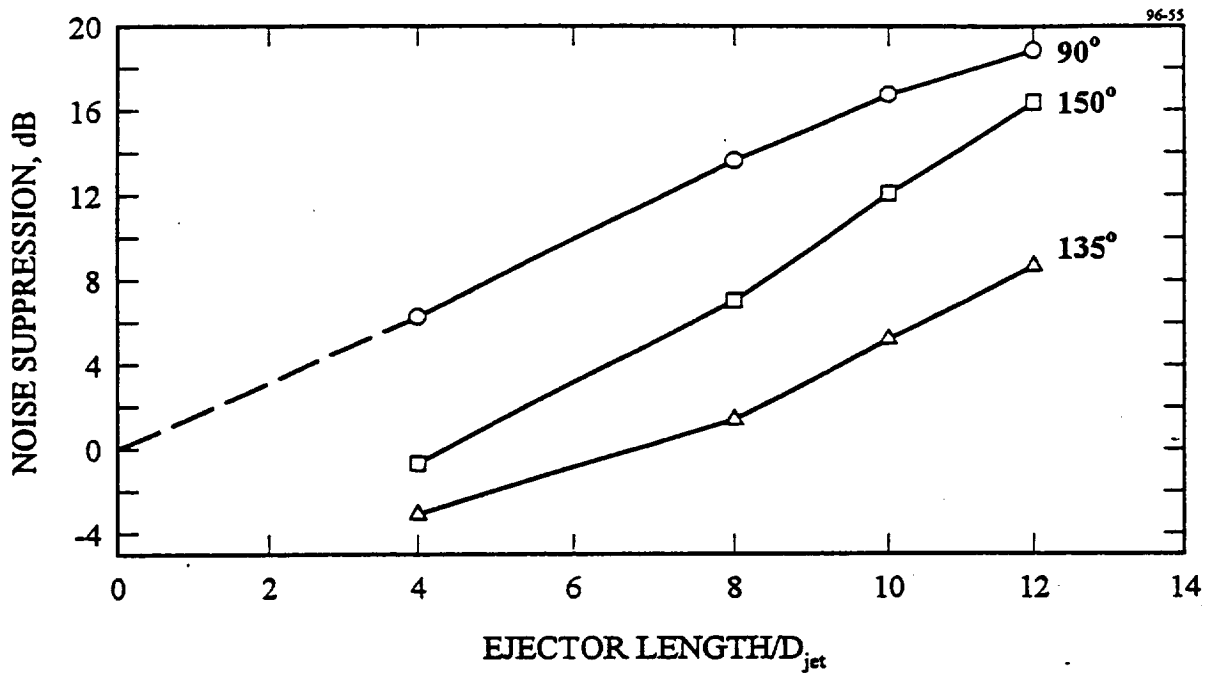

Fig. 28 Noise Suppression vs. Ejector Length in Mid-Frequency Range
 Main Jet NPR = 3.72
 2 auxiliary jets with NPR = 2.14
 Auxiliary jet mass flow = 5.6% of main jet

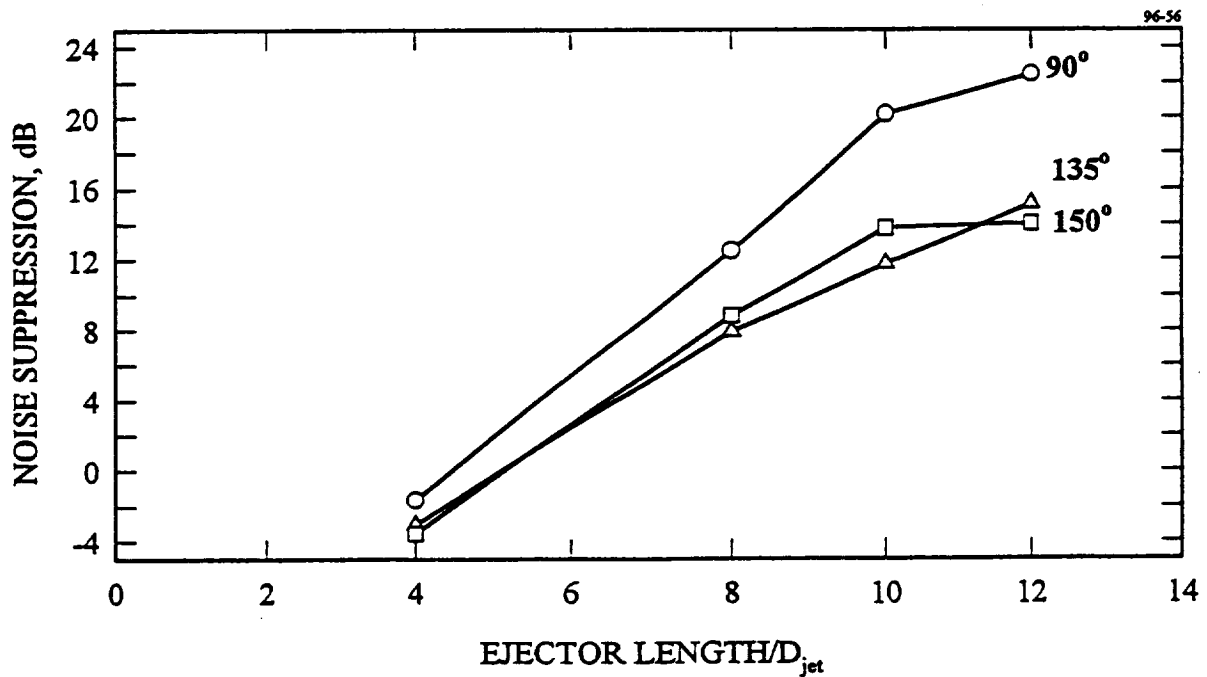

Fig. 29 Noise Suppression vs. Ejector Length for High Frequency Range
 Main Jet NPR = 3.72
 2 auxiliary jets with NPR = 2.14
 Auxiliary jet mass flow = 5.6% of main jet

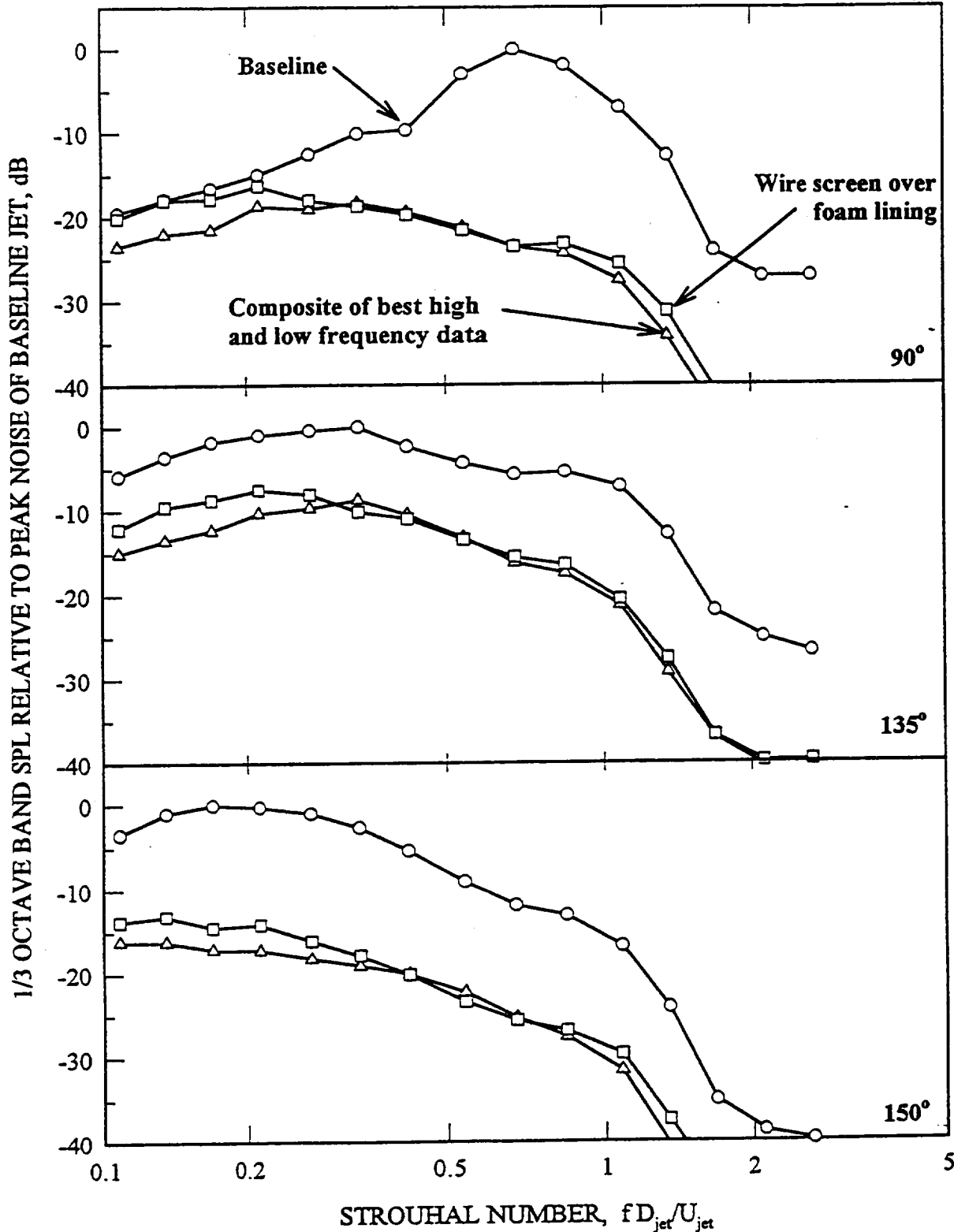

Fig. 30 Composite vs. Screen over Foam Lining
 Main jet NPR = 3.72
 4 auxiliary jets with NPR = 3.72
 Auxiliary jet mass flow = 5.6% of main jet

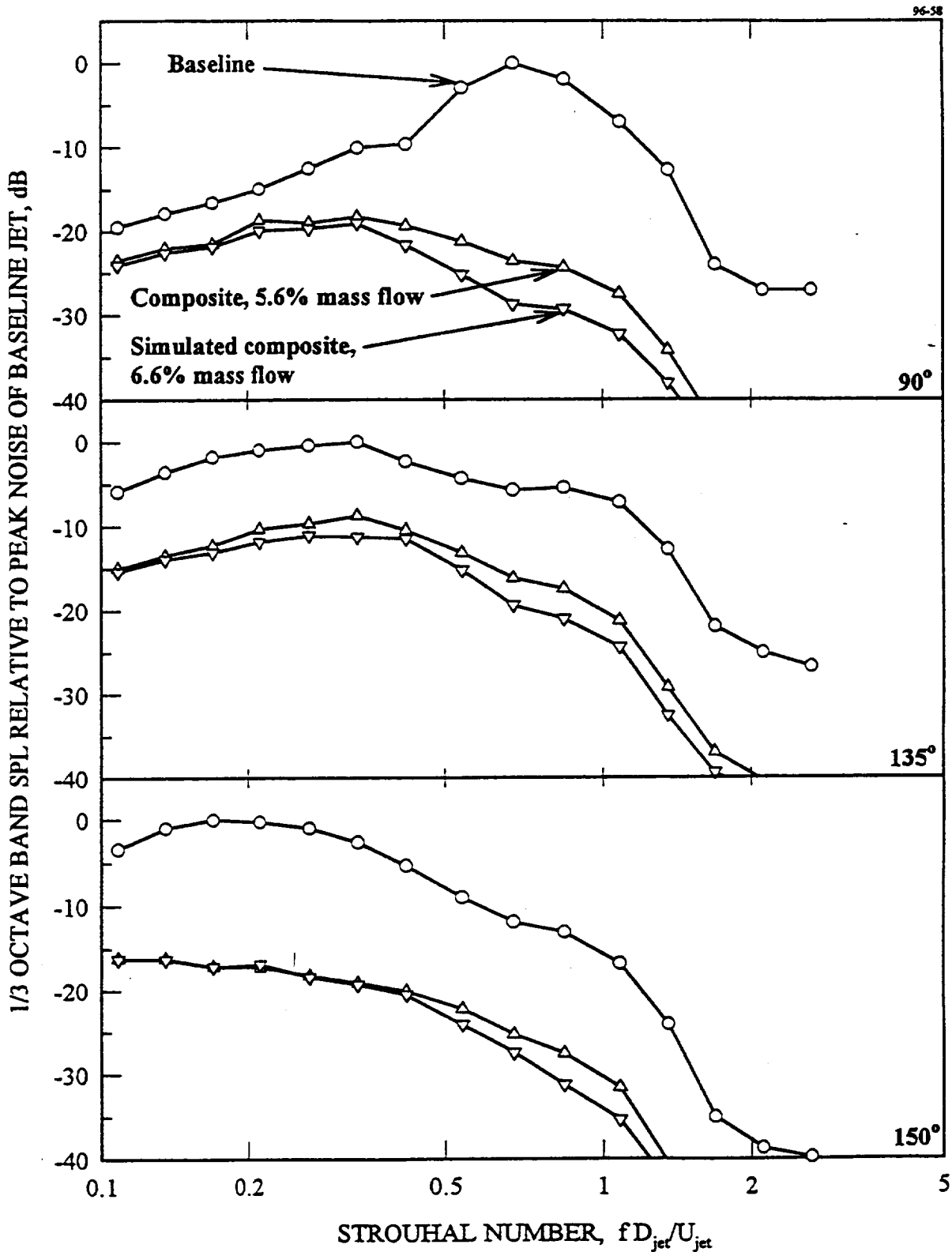

Fig. 31 Composite Case for High Mass Flow
 Main jet NPR = 3.72
 4 auxiliary jets

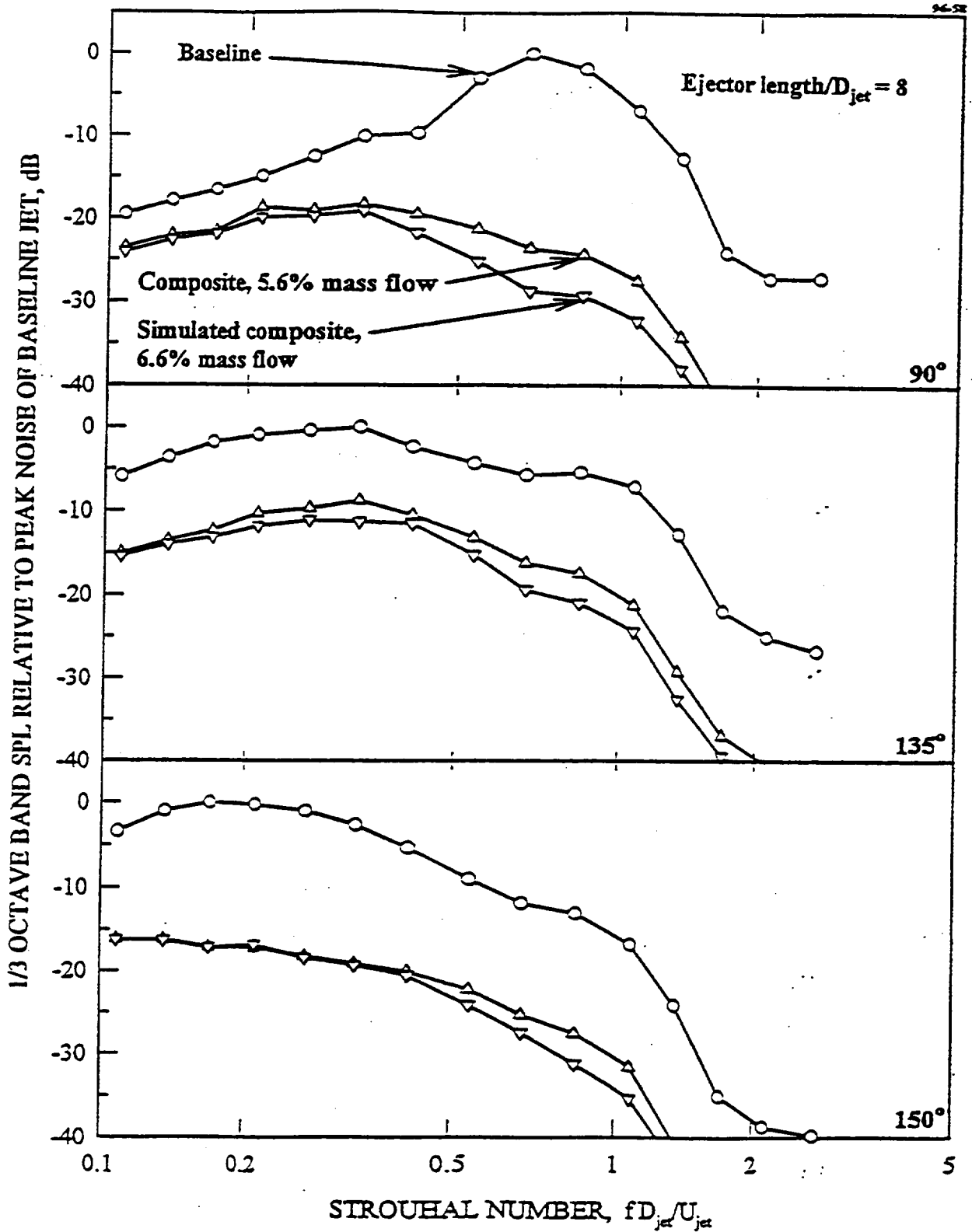

Fig. 32 Composite Case for High Mass Flow
 Main jet NPR = 3.72
 4 auxiliary jets

REPORT DOCUMENTATION PAGE

Form Approved
OMB No. 0704-0188

Public reporting burden for this collection of information is estimated to average 1 hour per response, including the time for reviewing instructions, searching existing data sources, gathering and maintaining the data needed, and completing and reviewing the collection of information. Send comments regarding this burden estimate or any other aspect of this collection of information, including suggestions for reducing this burden, to Washington Headquarters Services, Directorate for Information Operations and Reports, 1215 Jefferson Davis Highway, Suite 1204, Arlington, VA 22202-4302, and to the Office of Management and Budget, Paperwork Reduction Project (0704-0188), Washington, DC 20503.

1. AGENCY USE ONLY (Leave blank)	2. REPORT DATE June 1997	3. REPORT TYPE AND DATES COVERED Final Contractor Report	
4. TITLE AND SUBTITLE Ejector Noise Suppression With Auxiliary Jet Injection		5. FUNDING NUMBERS WU-244-02-01 C-NAS3-27246 SBIR	
6. AUTHOR(S) Charles H. Berman and Otto P. Andersen, Jr.			
7. PERFORMING ORGANIZATION NAME(S) AND ADDRESS(ES) AeroChem Research Laboratories, Inc. P.O. Box 12 Princeton, New Jersey 08542		8. PERFORMING ORGANIZATION REPORT NUMBER E-10570	
9. SPONSORING/MONITORING AGENCY NAME(S) AND ADDRESS(ES) National Aeronautics and Space Administration Lewis Research Center Cleveland, Ohio 44135-3191		10. SPONSORING/MONITORING AGENCY REPORT NUMBER NASA CR-202305	
11. SUPPLEMENTARY NOTES Project Manager, Eugene A. Krejsa, Structures and Acoustics Division, NASA Lewis Research Center, organization code 5940, (216) 433-3951.			
12a. DISTRIBUTION/AVAILABILITY STATEMENT Unclassified - Unlimited Released as Publicly Available January 1997 Subject Category 71 This publication is available from the NASA Center for AeroSpace Information, (301) 621-0390.		12b. DISTRIBUTION CODE	
13. ABSTRACT (Maximum 200 words) An experimental program to reduce aircraft jet turbulence noise investigated the interaction of small auxiliary jets with a larger main jet. Significant reductions in the far field jet noise were obtained over a range of auxiliary jet pressures and flow rates when used in conjunction with an acoustically lined ejector. While the concept is similar to that of conventional ejector suppressors that use mechanical mixing devices, the present approach should improve thrust and lead to lower weight and less complex noise suppression systems since no hardware needs to be located in the main jet flow. A variety of auxiliary jet and ejector configurations and operating conditions were studied. The best conditions tested produced peak to peak noise reductions ranging from 11 to 16 dB, depending on measurement angle, for auxiliary jet mass flows that were 6.6% of the main jet flow with ejectors that were 8 times the main jet diameter in length. Much larger reductions in noise were found at the original peak frequencies of the unsuppressed jet over a range of far field measurement angles.			
14. SUBJECT TERMS Noise; Jet noise; Ejectors; Suppressors; Mixers		15. NUMBER OF PAGES 56	
		16. PRICE CODE A04	
17. SECURITY CLASSIFICATION OF REPORT Unclassified	18. SECURITY CLASSIFICATION OF THIS PAGE Unclassified	19. SECURITY CLASSIFICATION OF ABSTRACT Unclassified	20. LIMITATION OF ABSTRACT