

RECENT ADVANCES IN THE ANALYSIS OF SPIRAL BEVEL GEARS

Robert F. Handschuh
U.S. Army Research Laboratory
Lewis Research Center
Cleveland, Ohio, U.S.A. 44135

Abstract A review of recent progress for the analysis of spiral bevel gears will be described. The foundation of this work relies on the description of the gear geometry of face-milled spiral bevel gears via the approach developed by Litvin. This methodology was extended by combining the basic gear design data with the manufactured surfaces using a differential geometry approach, and provides the data necessary for assembling three-dimensional finite element models. The finite element models have been utilized to conduct thermal and structural analysis of the gear system. Examples of the methods developed for thermal and structural/contact analysis are presented.

Key words: Spiral bevel gears, transmissions, finite element analysis

1 INTRODUCTION

Spiral bevel gears are currently used in all helicopter power transmission systems manufactured in the United States. These gears are required to transfer power from the horizontal engines to the vertical rotor shaft. Spiral bevel gears used in this capacity, are typically required to carry high loads and operate at very high rotational speeds. Therefore the efficient design of these components is very important.

Currently designers utilize gear standards, such as given in Ref. 1 to help them in their design process. Stress index values are calculated and the designer can quickly evaluate the contact and bending stress levels to those of their successful design experiences. When faced with designs outside of their experience, failures can occur or the resultant design will not be optimal. Therefore analytical tools that can enhance the design process are needed.

A typical aerospace spiral bevel gear configuration is shown in Fig. 1 (Ref. 2). In this case the overall gear reduction from the engine to the rotor shaft is approximately 80:1. The reduction is accomplished in two spiral bevel gear meshes and one planetary section. The input speed for this application is 21900 rpm and 1120 kW (1500 hp) per engine input. In this design not only are the bending and contact stress of interest, but also the thermal behavior or "flash temperature" is of interest. Many other aviation applications have similar operational characteristics.

Over the last ten years or so, many studies have been conducted on understanding, analyzing, and improving the surface geometry and meshing characteristics of spiral bevel gears (Refs. 3 to 8). Other researchers have also conducted studies in these areas (Refs. 9 to 15). Research in this area has its foundation in understanding and kinematically representing the manufacturing process. The basics of the machine for manufacture of spiral bevel gears

is shown in Fig. 2. Many completely mechanical versions of this machine tool are still in use today, but now are being replaced by six-axis computer numerically controlled machine tools (Refs. 16 and 17) that duplicate the generating motions.

Building on the very important fundamentals of gear manufacturing kinematics has been the extension of these techniques to produce 3-D finite element models (Ref. 18). Utilizing this numerical technique has resulted in sophisticated analysis of these complex models for thermal and structural analysis (Refs. 19 to 24).

The objective of this paper is to summarize the differential geometry approach to modeling the gear tooth surface geometry, document how three-dimensional models are developed, and provide examples using the finite element technique for solving thermal and structural/contact problems.

2 GEAR GEOMETRY VIA THE LITVIN METHOD

The modeling of spiral bevel gears is dependent on the proper kinematic analysis of the manufacturing process. As mentioned earlier, many researchers have spent a great deal of time and effort to accurately describe the resultant surfaces generated in the manufacturing process. In this paper the method developed by Litvin (Refs. 5 and 7) will be described in a very brief form.

The first step is in formulating the so called "equation of meshing." This equation states that the scalar product between the normal, n , to the cutting (grinding) surface and gear being generated and the relative velocity between the cutter and gear being generated, V , must equal zero at the specified location. Homogeneous coordinate transformations are utilized to incorporate rotations and translations between the different coordinate systems required to present the normal vector to the grinding surface along with the

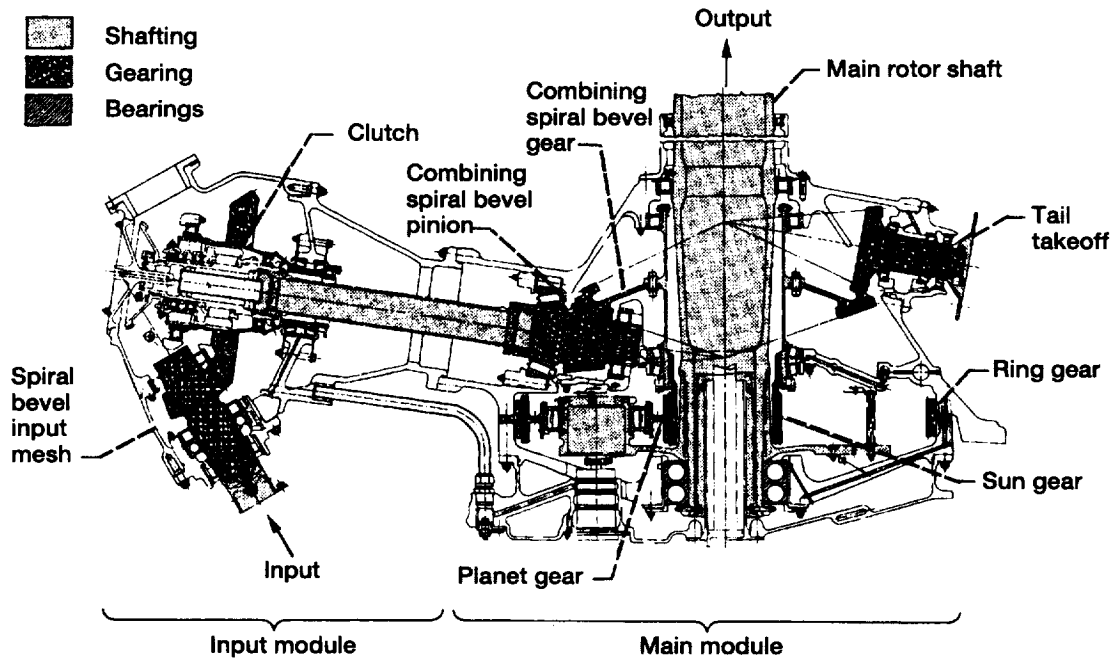

Figure 1.—Section view of UH-60A helicopter transmission.

relative velocity term in a common coordinate system. The equation is given as:

$$n \cdot V = 0 \quad (1)$$

Next, the basic gear design data to be analyzed must be given. This information includes the number of teeth of both members, the mean cone distance, spiral angle, shaft angle, and other basic data. Also, the gear member's cutter data, such as the cutter radius, point width, and blade angle are all assumed to be known.

As part of the complex analysis (Refs. 5 and 7), the slope of the transmission error curve, as shown in Fig. 3, the length of the long axis of the contact ellipse at an assumed light load deflection, and the orientation of the contact path on the gear surface are input as desired quantities into the computer program. Most users of this type of analysis refer to this as Tooth Contact Analysis (TCA). Based on the input data and the values for the transmission error curve slope and contact path, the machine tool settings are determined for the pinion and gear to accomplish the model requirements.

When using this modeling method, other system requirements must not be forgotten. In aerospace systems, the housings are made from lightweight materials such as magnesium, and the gear mesh must be able to tolerate a great deal of misalignment to be successful. Therefore, it is imperative that the mismatch between the surfaces be sufficient to permit operation of the gear mesh over the entire expected operating range. However, when

an abundance of mismatch is provided, the design can be plagued by excessive noise, vibration, and a lower load capacity.

3 THREE-DIMENSIONAL FINITE ELEMENT MODEL DEVELOPMENT

The next logical step beyond having the TCA description of the meshing gear system was to extend the information already determined by this analysis (machine settings for the pinion and gear) to calculate the gear tooth surface coordinates (Ref. 18). The equation of meshing for one member, pinion or gear, is an equation with three variables. Two more equations are constructed by determining and positions known to be on the active profile from the basic gear geometry. All that is required is to perform the coordinate transformations from the cutter coordinate system, S_c , to that of the gear being generated, S_w (see Fig. 4). Therefore the following two additional equations are formulated:

$$R - \bar{r} = 0 \quad (2)$$

$$Z - \bar{z} = 0 \quad (3)$$

where

$$R = \sqrt{x_w^2 + y_w^2} \quad \text{and} \quad Z = z_w$$

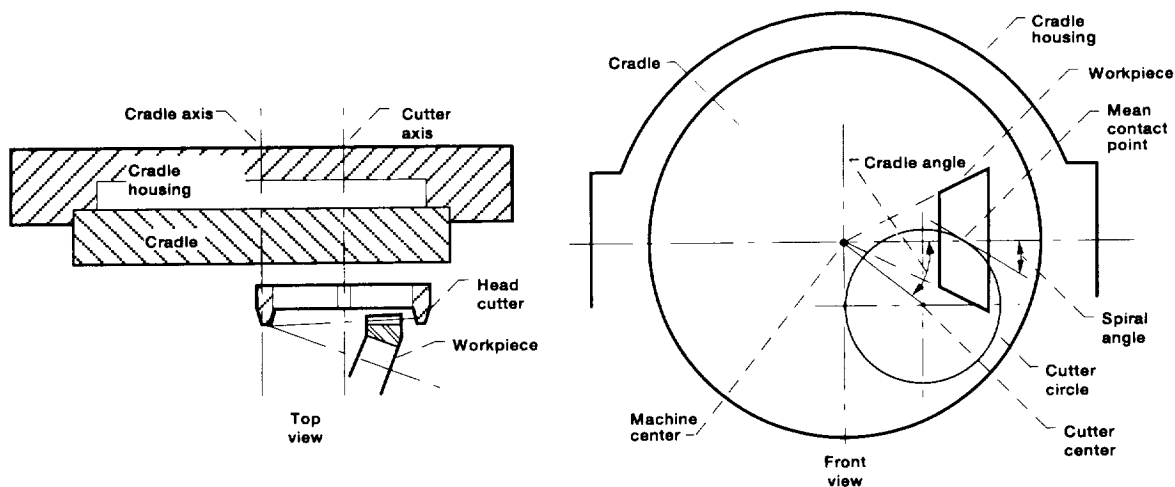

Figure 2.—Orientation of spiral bevel gear during manufacture relative to the generating machine.

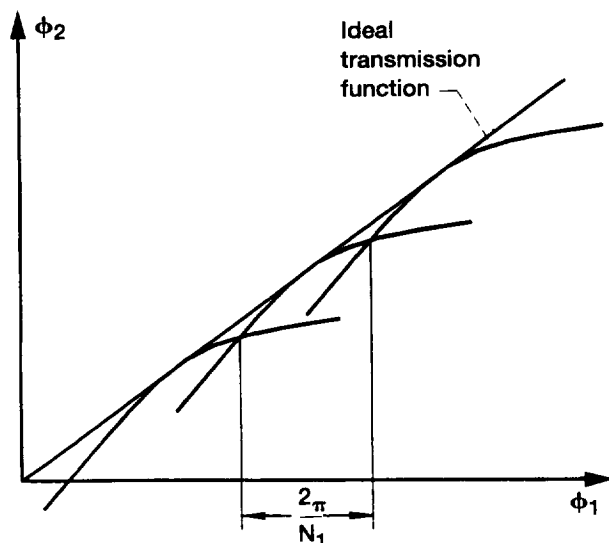

Figure 3.—Transmission error curves of the preferred parabolic type.

The values for R and Z in the S_w coordinate system are found by the following series of coordinate transformations:

$$r_w = [M_{wa}][M_{ap}][M_{pm}][M_{ms}][M_{sc}]r_c(u, \theta) \quad (4)$$

where the three variables are the position along the cutter cone, u , the location of the cutter position in coordinate system S_c , θ , and the cradle position ϕ_c . These variables are shown for a right-hand gear generation in Fig. 5. The other coordinate systems shown in Figs. 4 and 5 complete the entire transformation from the cutter to the gear being generated (Ref. 18).

The procedure for fully describing the active profile of the concave and convex sides of the gear profiles is currently accomplished by choosing a grid of positions and numerically solving for the actual coordinates in the coordinate system fixed to the pinion or gear under study. Utilizing this data and orienting the surfaces with the correct tooth thickness results in the model as shown in Fig. 6. This one-tooth sector model could be repeated to fully describe the entire gear if desired.

4 THERMAL ANALYSIS METHODOLOGY

The procedure to conduct the thermal analysis using the finite element method will now be discussed. The overall flow chart to conduct the analysis is shown in Fig. 7. As shown in the flow chart, the basic design data is required to initiate the analysis. Based on this information, that may be found on the summary sheet or some other calculation procedure, the machine tool setting program is run and a tooth contact analysis performed for the calculated machine settings. Several other analytical codes are then run to produce the finite element model, calculate the magnitude and locations where the heat flux will be applied when the gears mesh, and finally determine where the time and position varying boundary conditions will be applied to conduct the analysis.

The analysis is conducted using a nonlinear finite element code (Ref. 25). The model for analysis is developed in a commercially available geometric modeling package (Ref. 26). The finite element code has the capability to have subroutines that are compiled with the normal model bulk data, that can control the boundary conditions as a function of time and position. Also the subroutines can be exchanged and the model restarted.

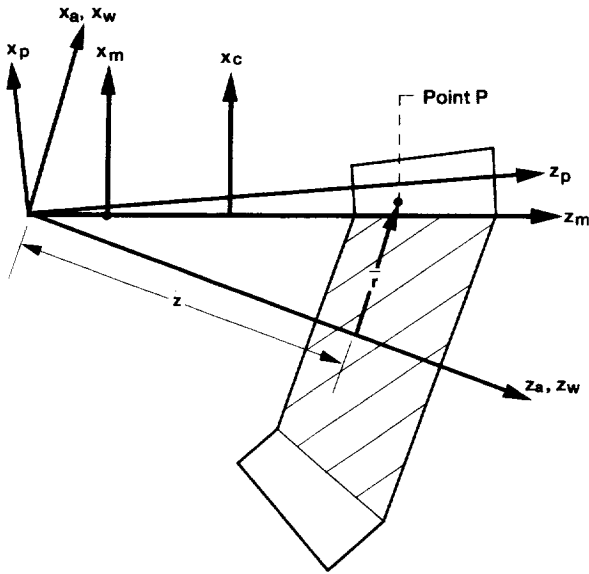

Figure 4.—Orientation of gear design requirements with respect to the gear manufacturing coordinate systems.

This proved to be very valuable to conduct the thermal analysis.

In any thermal analysis there are certain pieces of information that the analysis should produce. First of all the overall steady state behavior is desirable. The other information of great interest is the transient behavior. In the case of a spiral bevel gear, the boundary conditions are such that the heat flux is only on for a portion of time, then the same surface can convect heat to the surroundings or conduct heat into the gear tooth. Therefore the boundary conditions are a function of the rotational position on the active profile where the meshing takes place. Because of the large number of grid points and elements used in the analysis, running the model from initial conditions to that of a steady state conditions would take an extremely long period of time even on the fastest supercomputers. Therefore time averaging the heat flux boundary conditions were used to get the model out to steady state, then the model was restarted with the time and position varying boundary conditions applied.

5 STRUCTURAL/CONTACT ANALYSIS METHODOLOGY

The intent of conducting a structural/contact analysis is to gain a further description of the contact location, contact orientation, and the bending and contact stress experience by the teeth. This information can be found as a function of meshing position. Information to this level of detail is not available in the current standards, such as in Ref. 1. Many researchers and manufacturers may gain this type of information empirically using strain gages.

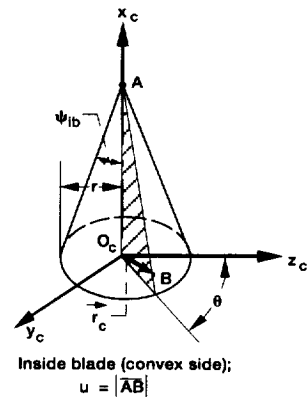

Inside blade (convex side);
 $u = |\overline{AB}|$

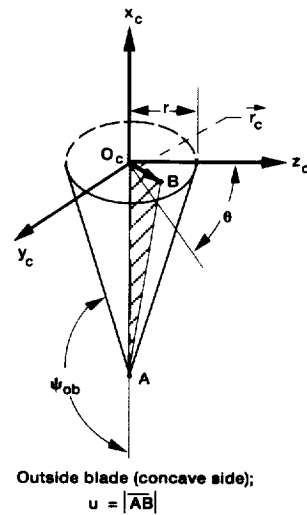

Outside blade (concave side);
 $u = |\overline{AB}|$

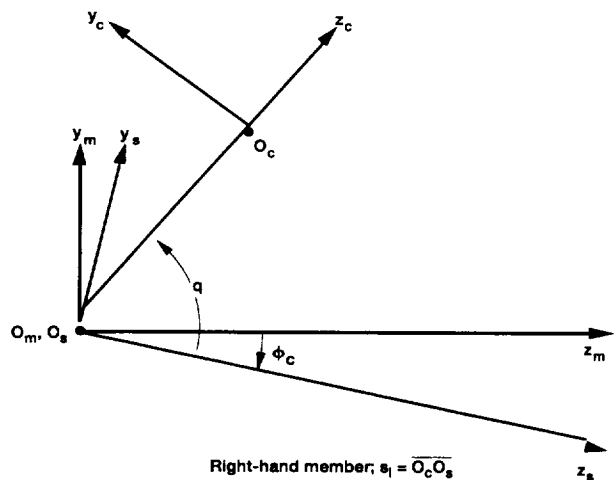

Right-hand member; $s_1 = \overline{O_c O_s}$

Figure 5.—Coordinate systems for the cutter and part of the generating machine.

Therefore an accurate analytical technique that could accurately predict the bending and contact stress would be highly advantageous.

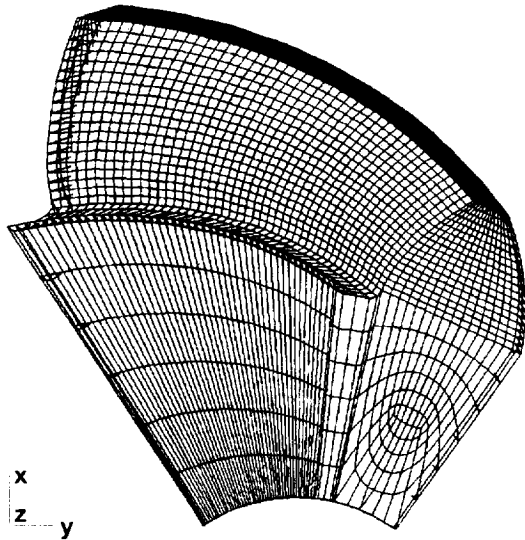

Figure 6.—Finite element model.

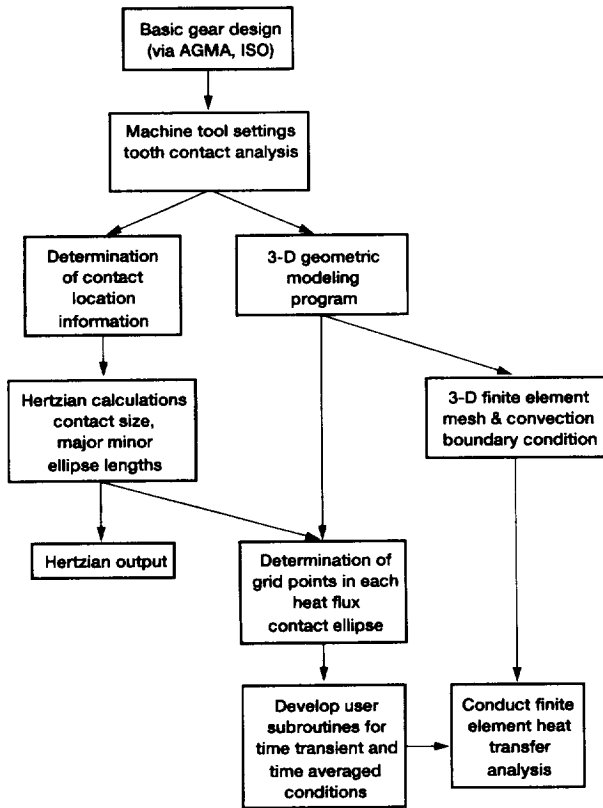

Figure 7.—Flow chart for the thermal analysis procedure.

Using the finite element method to conduct this type of analysis was initially more difficult. At that time gap elements were required to connect flexible members together. This presented many difficulties as the gap elements needed to be oriented normal to the surfaces as

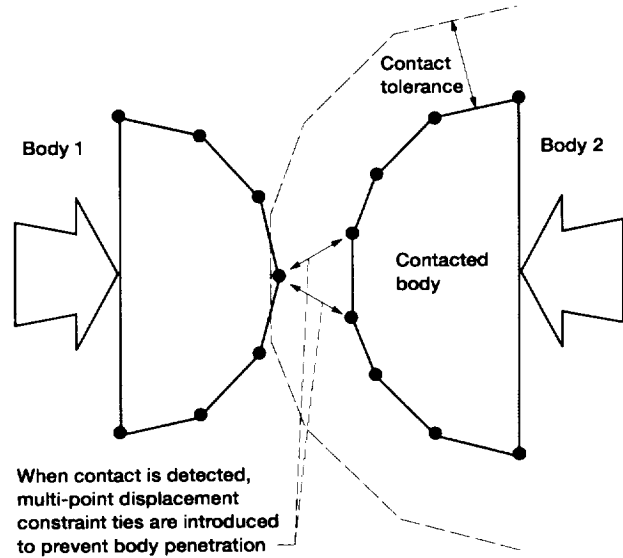

Figure 8.—Contact algorithm used for the 3-D structural analysis.

closely as possible. In an earlier study (Refs. 21 and 22) one of the gear pair's members needed to have the surface grid points reoriented to permit the near normal gap element requirements.

Fortunately progress has been made on improving the contact algorithms used in finite element analysis. This improvement is illustrated in Fig. 8. In the new technique a contact tolerance is determined by the analyst. The tolerance is based on the level of mesh refinement. The analysis requires that the loads be applied in increments to get the bodies initially in contact at light load and then are applied incrementally until the desired load level is reached. At each increment penetration of the bodies must be checked over the surfaces that are determined to be capable of being in contact with the other body.

This type of analysis does not require specific knowledge of where the possible contact locations would take place. Therefore at each increment the stiffness matrix of the model needs to be created. This reformulation at each time step uses a good amount of computer time. Therefore the amount and location of the mesh density should be seriously considered before the analysis is conducted.

Table 1 Pinion and Gear Design Data

	Pinion	Gear
Number of teeth	12	36
Dedendum angle, degree	1.5666	3.8833
Addendum angle, degree	3.8833	1.5666
Pitch angle, degree	18.4333	71.566
Shaft angle, degree	90	
Mean spiral angle, degree	35	
Face width, mm (in.)	25.4 (1.0)	

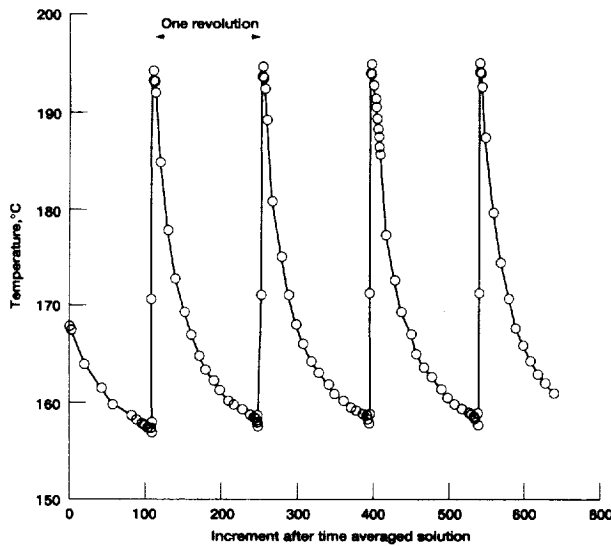

Figure 9.—Temperature variation for an active profile grid point shown for three revolutions after switching from the time averaged solution to the time and position varying solution.

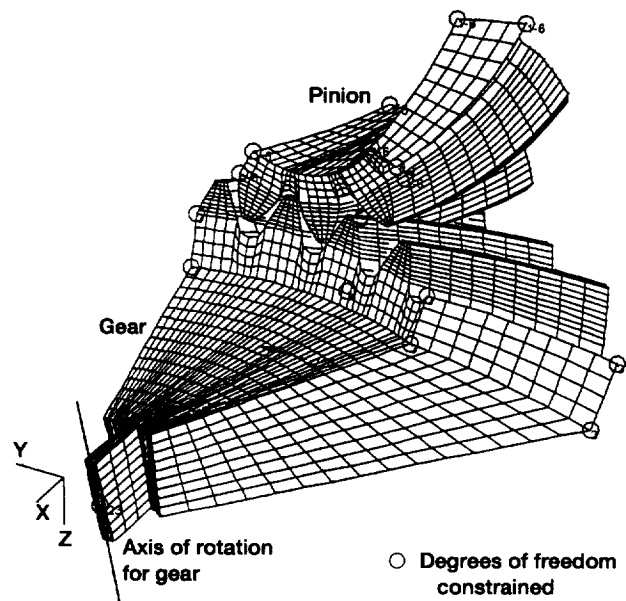

Figure 11.—Model used in the 3-D structural analysis.

generating machine settings can be found in Refs. 18, 19 and 22.

Thermal analysis

The model for the thermal analysis was previously shown in Fig. 6. The model was a one tooth sector of the pinion of the gear mesh under study. The model had over 20 000 elements and 22 500 grid points. The model first had the time-averaged boundary conditions applied, then the model was restarted and the time and position varying conditions were applied. In the time and position varying conditions, there were 144 time steps per revolution (every 2.5 degrees). More details of the boundary conditions can be found in Refs. 19.

Two different items of the thermal analysis will now be described. First a grid point of the active profile (meshing surface) will be followed for several revolutions. This is shown in Fig. 9. The solution using the time- and position-varying boundary conditions is shown initiating from the time-averaged boundary condition solution. This particular grid point was at a location on the active profile that received a great deal of heat flux. Note that the temperature excursions per revolution were very repeatable with a temperature "flash" of approximately 37 °C from the minimum temperature per revolution of about 158 °C.

The other part of the solution to look at is the entire temperature field. The model is shown in Fig. 10 during the meshing (heat flux application) portion of the analysis. The maximum temperature for this time increment was approximately 200 °C. By looking at the entire temperature field for all the time increments for a revolution provides the analyst with the temperature variation as a function of angular position. Investigating the results in this manner

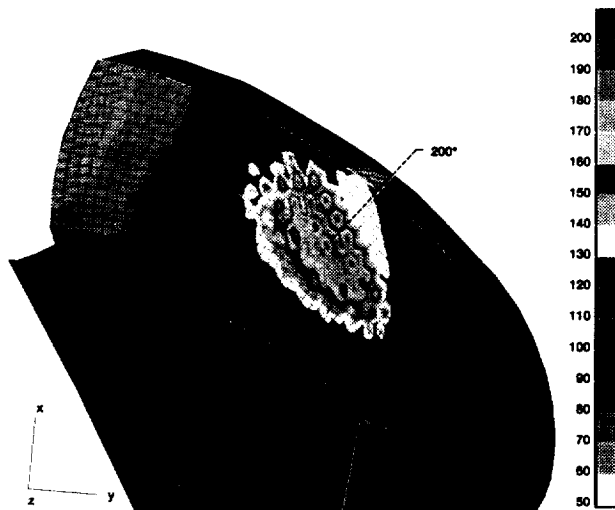

Figure 10.—Temperature variation shown for the entire model during a meshing step (°C).

The structural/contact analysis described uses the same finite element and geometric modeling programs that the thermal analysis uses.

6 EXAMPLE APPLICATIONS

Using the modeling procedures already discussed, an example of a thermal and structural/contact analysis will now be provided. Both analyses were conducted on the basic model data shown in Table I. Details on the

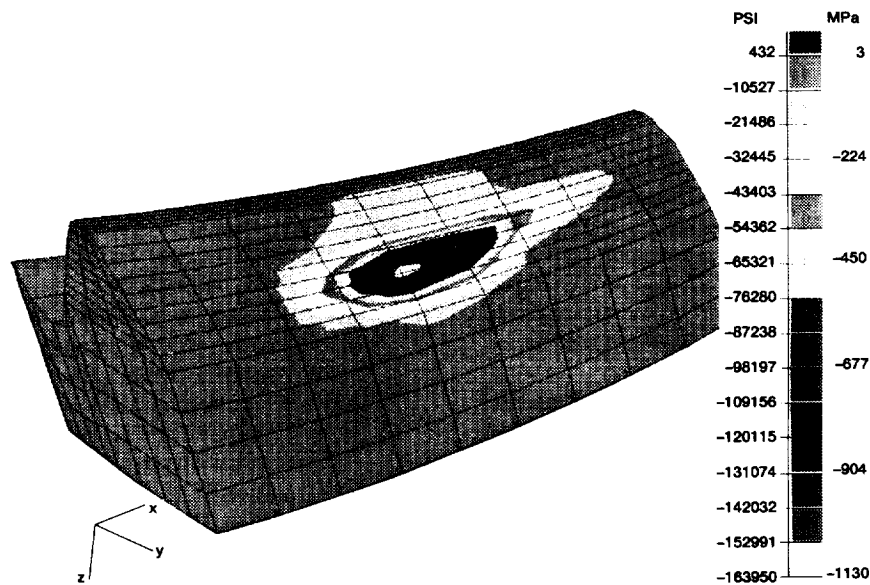

Figure 12.—Gear tooth stress field from the structural analysis.

revealed that only the elements on the active profile and the nearly surrounding gear body are affected by the time- and position-varying boundary conditions. Locations on the model at the toe and heel faces maintain the same temperature as was found by the time averaged solution.

Structural/contact analysis

The structural/contact analysis of the same basic model as given in Table I will now be described (Ref. 22). The model constructed for this analysis is shown in Fig. 11. Three pinion teeth and four gear teeth were used to construct the model. The pinion was fixed at the locations shown in Fig. 11 and the gear was constrained from moving axially, but was allowed to rotate. The torque was input to the model via a force on the gear body at a known radial position. This caused the gear to rotate into the pinion and initiate the contact between the two members. The model had a total of 8793 elements and 11261 grid points that translate into 33748 degrees of freedom. For conditions representative of the full load conditions for this gear mesh resulted in the stress field shown in Fig. 12 for one of the gear teeth. The stresses plotted are the minimum principle. Note the concentration of stresses on the active profile showing the region of contact between the surfaces. Similar plots could have been plotted to show the maximum bending in the fillet or some other region of concern. Therefore the information presented in this section holds promise for providing data of these complex gear members for thermal or structural/contact analysis. Much work, however, still needs to be completed and the proper validation with experiments are paramount to designers using the advanced finite element tools.

7 CONCLUSIONS

Recent advances in the analysis of spiral bevel gears have been presented. Analysis techniques that have been developed to describe the generated tooth surfaces were discussed. The differential geometric approach was combined with the gear design information to building a three-dimensional model. Development of three-dimensional models have provided the foundation for using the finite element method for thermal and structural/contact analysis. Results using the finite element technique have shown that complex models and boundary conditions can be formulated for analyzing spiral bevel gears.

REFERENCES

- 1 ANSI/AGMA 2003-A86, American National Standard Institute/American Gear Manufacturers Association, Rating the Pitting Resistance and Bending Strength of Generated Straight Bevel, ZEROL, Bevel, and Spiral Bevel Gear Teeth. June, 1988.
- 2 Oswald, F.: Gear Tooth Stress Measurements on the UH-60A Helicopter Transmission. NASA TP-2698, 1987.
- 3 Litvin, F.; Rahman, P.; and Goldrich, R.: Mathematical Models for the Synthesis and Optimization of Spiral Bevel Gears. NASA CR-3553, 1982.
- 4 Litvin, F.; Tsung, W.; and Lee, H.: Generation of Spiral Bevel Gears with Conjugate Tooth Surfaces and Tooth Contact Analysis. NASA CR-4088, 1987.
- 5 Litvin, F.; and Lee, H.: Generation and Tooth Contact Analysis of Spiral Bevel Gears With Pre-designed Parabolic Functions of Transmission Errors. NASA CR-4259, 1989.
- 6 Litvin, F.: Theory of Gearing. NASA RP-1212, 1989.

- 7 Litvin, F.; and Zhang, Y.: Local Synthesis and Tooth Contact Analysis of Face-Milled Spiral Bevel Gears. NASA CR-4342, 1991.
- 8 Litvin, F.: Gear Geometry and Applied Theory. Prentice Hall, New Jersey, 1994.
- 9 Krenzer, T.: Tooth Contact Analysis of Spiral Bevel Gear and Hypoid Gears Under Load. SAE Paper 810688, 1981.
- 10 Cloutier, L.; and Gosselin, C.: Kinematic Analysis of Spiral Bevel Gears. ASME Paper 84-DT-177, Oct. 1984.
- 11 Gosselin, C.; Cloutier, L.; and Brousseau, J.: Tooth Contact Analysis of High Conformity Spiral Bevel Gears. JSME Int. Conf. On Motion and Power Transmission, Hiroshima, Japan, Nov. 1991.
- 12 Gosselin, C.; Cloutier, L.; and Nguyen, Q.: The Influence of the Kinematical Motion Error of Spiral Bevel Gears. AGMA Fall Technical Meeting, 1992.
- 13 Stadtfeld, H.: Handbook of Bevel and Hypoid Gears, Rochester Institute of Technology, College of Engineering, 1993.
- 14 Fong, Z.; and Tsay, C.: A Mathematical Model for the Tooth Geometry of Circular-Cut Spiral Bevel Gears. J. of Mech. Design, Vol. 113, June 1991.
- 15 Fong, Z.; and Tsay, C.: Kinematic Optimization of Spiral Bevel Gears. J. of Mech. Design, Vol. 114, pp. 498-506, Sept. 1992.
- 16 Krenzer, T.; and Yunker, K.: Understanding the Phoenix Universal Bevel and Hypoid Generator. The Gleason Works, Rochester, NY.
- 17 Goldrich, R.: Theory of 6-Axis CNC Generation of Spiral Bevel and Hypoid Gears, The Gleason Works, Rochester, NY, 1989.
- 18 Handschuh, R.; and Litvin, F.: A Method for Determining Spiral Bevel Gear Tooth Geometry for Finite Element Analysis. NASA TP-3096, Aug., 1991.
- 19 Handschuh, R.: Thermal Behavior of Spiral Bevel Gears. Ph.D. Dissertation, Case Western Reserve University, August, 1993.
- 20 Handschuh, R.; and Kicher, T.: Experimental and Analytical Assessment of the Thermal Behavior of Spiral Bevel Gears. 1996 AGMA Fall Technical Meeting, NASA TM-107009, ARL-CR-852.
- 21 Bibel, G.; Kumar, A.; and Reddy, S.: Contact Stress Analysis of Spiral Bevel Gears Using Non-linear Finite Element Static Analysis. NASA TM-106176, ARL-TR-158, AIAA-93-2296, May, 1993.
- 22 Bibel, G.; Tiku, K.; and Kumar, A.: Prediction of Contact Path and Load Sharing in Spiral Bevel Gears. NASA CR-195305, ARL-CR-146, April, 1994.
- 23 Bibel, G.; Tiku, K.; Kumar, A.; and Handschuh, R.: Comparison of Gap Elements and Contact Algorithm for 3D Contact Analysis of Spiral Bevel Gears. NASA TM-106643, ARL-TR-478, 1994.
- 24 Bibel, G.; and Handschuh, R.: Meshing of a Spiral Bevel Gearset with 3D Finite Element Analysis, NASA TM-107336, ARL-TR-1224, October, 1996.
- 25 MARC K-5.1 User Manual, MARC Analysis Research Corporation, Palo Alto, California, 1981.
- 26 PATRAN Users Manual, PA Engineering, Costa Mesa, California, 1991.

REPORT DOCUMENTATION PAGE

Form Approved
OMB No. 0704-0188

Public reporting burden for this collection of information is estimated to average 1 hour per response, including the time for reviewing instructions, searching existing data sources, gathering and maintaining the data needed, and completing and reviewing the collection of information. Send comments regarding this burden estimate or any other aspect of this collection of information, including suggestions for reducing this burden, to Washington Headquarters Services, Directorate for Information Operations and Reports, 1215 Jefferson Davis Highway, Suite 1204, Arlington, VA 22202-4302, and to the Office of Management and Budget, Paperwork Reduction Project (0704-0188), Washington, DC 20503.

1. AGENCY USE ONLY (Leave blank)	2. REPORT DATE June 1997	3. REPORT TYPE AND DATES COVERED Technical Memorandum	
4. TITLE AND SUBTITLE Recent Advances in the Analysis of Spiral Bevel Gears		5. FUNDING NUMBERS WU-581-30-13 1L162211A47A	
6. AUTHOR(S) Robert F. Handschuh		7. PERFORMING ORGANIZATION NAME(S) AND ADDRESS(ES) NASA Lewis Research Center Cleveland, Ohio 44135-3191 and U.S. Army Research Laboratory Cleveland, Ohio 44135-3191	
8. PERFORMING ORGANIZATION REPORT NUMBER E-10587		9. SPONSORING/MONITORING AGENCY NAME(S) AND ADDRESS(ES) National Aeronautics and Space Administration Washington, DC 20546-0001 and U.S. Army Research Laboratory Adelphi, Maryland 20783-1145	
10. SPONSORING/MONITORING AGENCY REPORT NUMBER NASA TM-107391 ARL-TR-1316		11. SUPPLEMENTARY NOTES Prepared for the International Conference on Mechanical Transmissions and Mechanisms cosponsored by the Mechanical Transmission Institution of the Chinese Mechanical Engineering Society, IFToMM Member Committee of China, and Tianjin University, Tianjin, People's Republic of China, July 1-4, 1997. Responsible person, Robert F. Handschuh, organization code 5950, (216) 433-3969.	
12a. DISTRIBUTION/AVAILABILITY STATEMENT Unclassified - Unlimited Subject Category 37 This publication is available from the NASA Center for AeroSpace Information, (301) 621-0390.		12b. DISTRIBUTION CODE	
13. ABSTRACT (Maximum 200 words) A review of recent progress for the analysis of spiral bevel gears will be described. The foundation of this work relies on the description of the gear geometry of face-milled spiral bevel gears via the approach developed by Litvin. This methodology was extended by combining the basic gear design data with the manufactured surfaces using a differential geometry approach, and provides the data necessary for assembling three-dimensional finite element models. The finite element models have been utilized to conduct thermal and structural analysis of the gear system. Examples of the methods developed for thermal and structural/contact analysis are presented.			
14. SUBJECT TERMS Gears; Transmissions; Finite element analysis; Spiral bevel gears		15. NUMBER OF PAGES 10	
		16. PRICE CODE A02	
17. SECURITY CLASSIFICATION OF REPORT Unclassified	18. SECURITY CLASSIFICATION OF THIS PAGE Unclassified	19. SECURITY CLASSIFICATION OF ABSTRACT Unclassified	20. LIMITATION OF ABSTRACT