

AGARD Conference

NASA-TM-112908

*7-5-97
049517*

Paper C37 Systems Challenges for Hypersonic Vehicles

by

James L. Hunt

NASA Langley Research Center
Hampton, Virginia

and

Gerard Laruelle and

Alain Wagner

Aerospaciale Espace & Defense

Future Aerospace Technology in the Service of the Alliance

April 14-16, 1997

**ECOLE POLYTECHNIQUE
PALAISEAU near PARIS, FRANCE**

Systems Challenges for Hypersonic Vehicles

by

James L. Hunt

NASA Langley Research Center

Gerard Laruelle and Alain Wagner

Aerospatiale Espace & Defense

1. Abstract
2. Introduction
3. Cruise Airplanes
 - 3.1 Hydrocarbon Fueled Airplanes ($M < 8$)
 - 3.1.1 Baseline
 - 3.1.1.1 Propulsion Systems/Integration
 - 3.1.1.2 Thermal Management/Power Generation
 - 3.1.1.3 Structures/Materials/Tank Systems
 - 3.1.1.4 Challenges
 - 3.2 Hydrogen Fueled Airplanes ($M > 8$)
 - 3.2.1 Baseline (2 ducts) — Underslung, over/under turboram/ram-scam
 - 3.2.1.1 Propulsion
 - 3.2.1.2 Thermal Management
 - 3.2.1.3 Fuel Supply
 - 3.2.1.4 Pressurization and Purge
 - 3.2.1.5 Vehicle Management/Avionics
 - 3.2.1.6 Airframe Structure/TPS/Leading Edge
 - 3.2.1.7 Leading Edge Systems
 - 3.2.1.8 Power Generation
 - 3.2.1.9 Actuation
 - 3.2.1.10 Challenges
 - 3.2.2 Ejector Ramjet/Ram-Scramjet (1 duct)
 - 3.2.3 LACE Ejector Ramjet/Ram-Scramjet (1.5 ducts)
 4. Access to Space
 - 4.1 Single-Stage-to-Orbit (SSTO) Vehicles
 - 4.1.1 Airbreathing SSTO Vehicles
 - 4.1.1.1 Example Baseline
 - 4.1.1.1.1 Architecture
 - 4.1.1.1.2 Trajectory/Engine Modes
 - 4.1.1.1.3 Thermal Management
 - 4.1.1.1.4 Subsystems
 - 4.1.1.1.5 Challenges
 - 4.1.2 Rocket-Powered SSTO Vehicles
 - 4.1.2.1 Example Baseline
 - 4.1.2.1.1 Architecture
 - 4.1.2.1.2 Reference Systems/Technologies
 - 4.1.2.1.3 Challenges
 - 4.2 Two-Stage-to-Orbit (TSTO) Vehicles
 - 4.2.1 TSTO Vehicles With Airbreathing Powered Boosters/Rocket Powered Orbiters
 - 4.2.1.1 Example Baseline
 - 4.2.1.1.1 Staging Trade
 - 4.2.1.1.2 Challenges
 - 4.2.2 TSTO Vehicles With Rocket Powered Boosters/Rocket Powered Orbiters
 - 4.2.2.1 High Staging Speed Concepts (beyond 10,000 ft./sec.)
 - 4.2.2.2 Staging Speed Near 3,000 ft./sec.
 - 4.2.2.2.1 LOX/LHC Siamese Pop-Down Concept
 - 4.2.2.3 Challenges
 5. Advanced, Enhancing Systems Concepts
 6. Common Systems Challenges
 - 6.1 Guidance, Navigation and Control (GN&C)
 - 6.2 Telecommunications
 - 6.3 Reliability, Availability, Maintainability and Safety
 - 6.4 Operations
 7. Concluding Remarks
 8. References

Systems Challenges for Hypersonic Vehicles

by

James L. Hunt
 NASA Langley Research Center
 Gerard Laruelle and Alain Wagner
 Aerospatiale Espace & Defense

1. ABSTRACT

This paper examines the system challenges posed by fully reusable hypersonic cruise airplanes and access to space vehicles. Hydrocarbon and hydrogen fueled airplanes are considered with cruise speeds of Mach 5 and 10, respectively. The access to space matrix is examined. Airbreathing and rocket powered, single- and two-stage vehicles are considered. Reference vehicle architectures are presented. Major systems/subsystems challenges are described. Advanced, enhancing systems concepts as well as common system technologies are discussed.

2. INTRODUCTION

Vehicles for sustained hypersonic flight encompass airplanes, space access vehicles and missiles. Functional and architectural categories impose major differentiation from a systems/subsystems perspective. Important categories are: a) take-off (launch); horizontal, vertical, staged/air-dropped or launch assist, b) landing; horizontal or vertical, c) propulsion: airbreathing, rocket or combination, d) fuel (propellant): cryogenic and/or noncryogenic, solid or liquid, e) reusability: expendable or reusable, f) mission: cruise, acceleration, or combination, and g) staging: one versus two or more. In order to constrain the scope of this paper, air-dropped, launch assist, vertical landing, solid propellants systems and expendables including missiles will be omitted.

There are also commonalities in the system challenges across the hypersonic vehicle matrix. These commonalities exist primarily within the framework of features/disciplines that

are unique to the vehicles for sustained hypersonic flight, i.e. structures, materials, and thermal protection systems (TPS) compatible with the very high thermal constraints of sustained hypersonic flight and the requirement for extremely low dry weight. There are also commonality requirements such as fast response of the control systems in which nonlinearities and cross-couplings are the norm.

Herein, system challenges for hypersonic vehicles will be addressed in terms of endoatmospheric operations and exoatmospheric delivery/return with major systems differentiations such as hydrocarbon and hydrogen fuel for airplanes and airbreathing and rocket propulsion for access to space vehicles.

3. CRUISE AIRPLANES

For hypersonic airplanes, range for a given payload at a given cruise Mach number is a good figure of merit (ref. 1). How is this figure of merit impacted for hydrocarbon-fueled airplanes and liquid hydrogen-fueled airplanes? Calculations indicate that Mach 8 is approximately the cruise speed limit to which a dual-mode ramjet/scramjet can be cooled with endothermic fuels (depends on contraction ratio and dynamic pressure, ref. 1). On the other hand, liquid hydrogen has much more cooling capacity and provides considerably more range than hydrocarbons for the same Mach as indicated in figure 1. The range of hydrogen fueled vehicles maximizes at about Mach 10, beyond the cooling limits of the hydrocarbons. The take-off gross weight (TOGW) of the hydrocarbon-fueled airplanes is much greater for the same cruise Mach number than that for hydrogen-fueled airplanes as shown in figure 2. Although the dry weight of hydrocarbon vs. hydrogen airplanes for the same cruise Mach number and for the same

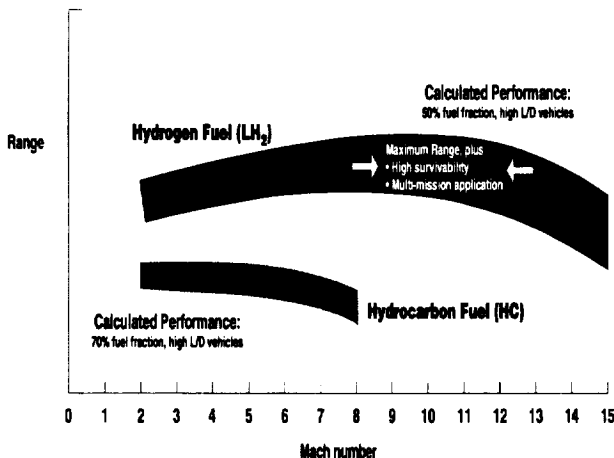

Figure 1. Range potential for hypersonic airplanes (fixed payload, ref. 1).

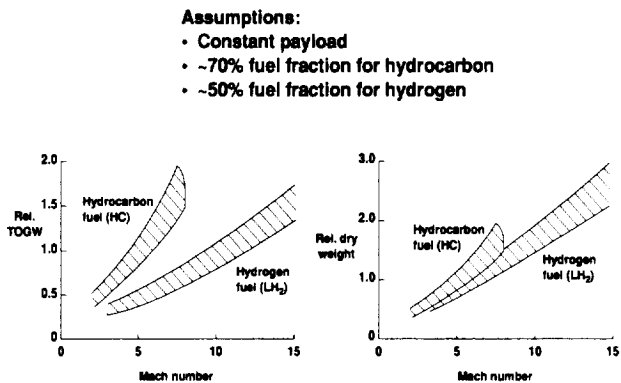

Figure 2. Weight potential for hypersonic airplanes (fixed payload, ref. 1).

payload is much closer, it still tends to break favorably for the hydrogen-fueled aircraft (figure 2).

Thus, for airplanes the fuel break appears to be about Mach 8; that is, endothermic fueled/ hydrocarbon vehicles are limited to below Mach 8 and airplanes with cruise speed above Mach 8 will require hydrogen. Since the shape of the vehicle and the systems that constitute it will be considerably different for hydrocarbon-fueled machines than for hydrogen because of the fuel density differences and resultant planform to accommodate loading, the discussion will be broken along these lines with the assumption that the speed break point is Mach 8 even though hydrogen-fuel systems could be designed for lower cruise Mach numbers. The hybrid approach, dual-fuel, will be considered as a subset of hydrogen-fueled systems.

Other than the fuel, the biggest influence on the system architectures will come from engine integration. All hypersonic airplanes considered herein are engine-airframe integrated in that the forebody serves as an external precompression surface for the engine inlet and the aftbody as a high expansion ratio nozzle. Also, for the purpose of discussion continuity, the airbreathing propulsion flowpath is considered on the lower surface of the vehicle (underslung). The differences are in whether the engine integration embodies a single duct or a two-duct approach, or something in between.

3.1 Hydrocarbon Fueled Airplanes ($4 < M < 8$)

The engine integration architecture for hydrocarbon-fueled hypersonic airplanes depends on the design cruise speed of the vehicle. For cruise Mach numbers between 4 and 5, underslung, single-duct, turbojet, airframe-integrated systems can be used. For cruise Mach numbers between 5 and 8, two-duct, turbojet/ramjet-scramjet, over/under, airframe-integrated systems are required. Single duct, ejector-ramjet, airframe-integrated systems do not appear favorable for hydrocarbon-fueled airplanes because of the low efficiency of the propulsion system and the large planform loading incurred by the airplane due to the high propellant density of hydrocarbon fuel plus liquid oxygen (LOX) used for an oxidizer in the ejector rocket motors.

For hypersonic speeds, liquid hydrocarbon (LHC) fuels must be selected primarily on cooling characteristics. Fuels with the highest energy per pound of cooling capacity are required; this class of fuels is endothermic. Thus, when heat is added to

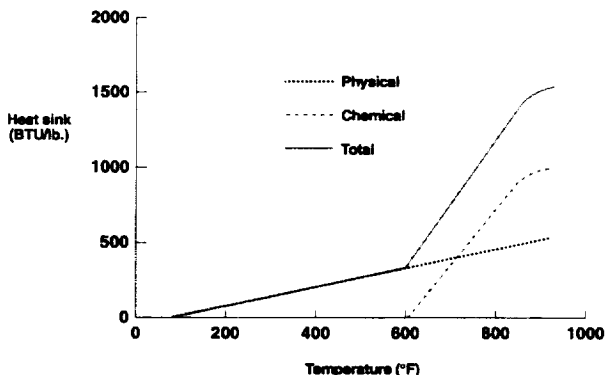

Figure 3. Heat sink of methylcyclohexane (approximate).

the fuel in the presence of a catalyst, the fuel is transformed through an endothermic chemical reaction in which the original fuel molecules decompose into combustible chemical constituents with the absorption of substantial amounts of heat (figure 3). The catalyst can be applied inside the cooling panels of the engine for direct cooling or a secondary fluid can be used with the catalyst being applied to one side of a heat exchanger which is outside of the engine for indirect cooling. The most likely solution would be to use a combination of direct and indirect cooling systems as was used for the Mach 5 waverider airplane design study in reference 2.

3.1.1 Example Baseline

The Mach 5 waverider airplane (ref. 2) was selected as a reference vehicle design (example baseline), representing system architectures for hydrocarbon fueled, hypersonic airplanes. It is an underslung, over/under, turbojet/ramjet, two-duct airframe-integrated design. A 3-view drawing of the Mach 5 waverider configuration is presented in figure 4. Performance estimates (ref. 2) indicated a 6,000 nm tanker-to-tanker range with a refueled gross weight of 550K lbs.; take-off gross weight (TOGW) was 400K lbs. with an empty weight (EW) of 141K lbs., and a vehicle length of 135 ft.

3.1.1.1 Propulsion System/Integration

As designed (ref. 2), the baseline waverider airplane, fueled by an advanced paraffin endothermic would be powered by four turboramjet engines. The STRJ-1011 powerplant system design was supplied by Pratt & Whitney and is based on current technology using endothermic fuel. The turbojet would operate from take-off to turbojet/ramjet transition (approximately Mach 2-3). The ramjet engine is to be started at a low supersonic Mach number and operated in parallel with the turbojet through transition, after which the ramjet would operate alone to complete the high-Mach acceleration and cruise.

The over/under integration of the turbojet/ramjet engines is shown in the propulsion system schematic of figure 5. An effective transition from a conical flowfield to a 2-D variable geometry inlet is provided. Inlet strakes (figure 4) are incorporated to isolate each inlet in case of an unstart or engine-out condition in one module. The outboard strakes are extended forward to control side spillage. The cowl is fixed so flow con-

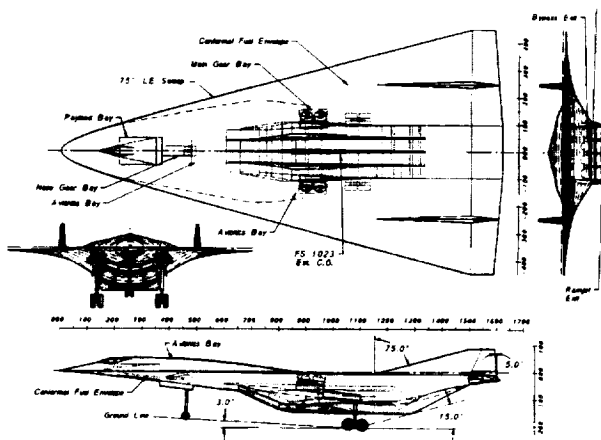

Figure 4. Aircraft three-view (ref. 2).

trol in the inlet is to be accomplished by the variable bodyside ramp system. A splitter vane that controls the flow between the turbojet and ramjet is located behind the inlet throat.

A boundary-layer diverter duct (figure 5) was integrated just forward of the first external inlet ramp to remove the low energy boundary-layer flow during turbojet operation only. This may not preclude the need for bleed internal to the inlet, but it does minimize the volume required, and thus, simplifies the bleed system. Inlet bleed has a substantial impact on range performance; with an 8% inlet bleed, the tanker-to-tanker range was 6,000 nm... assuming inlet functionality, the range was 7,600 nm without the bleed.

The turbojet, turbojet nozzle, ramburner, ramjet nozzle, and external expansion nozzle are aligned in a 2-D arrangement. As seen in figure 5, a door opens to allow the turbojet nozzle flow to exit to the external nozzle just above the ramjet nozzle. As conceived, the ramjet will be started at approximately Mach 2. When the turbojet shuts down at Mach 2.5, the turbojet nozzle exit doors seal shut, leaving a large, unobstructed expansion surface.

3.1.1.2 Thermal Management / Power Generation

Both direct and indirect fuel cooling were used in the reference design (ref. 2). In either case, a catalyst is needed to promote the endothermic chemical reaction of the fuel. The thermal management system is shown in figure 6. Direct fuel cooling is used in the ramburner and nozzle where the heat load is highest. For these areas, the catalyst is installed on the inside of the superalloy cooling panels. Indirect cooling is used for the inlet, avionics, and turbojet engine bay, and a catalytic heat exchanger reactor (CHER) is employed to transfer heat from the low-viscosity, secondary fluid to the fuel. The inlet has integral titanium alloy cooling panels with insulation and a cobalt L-605 heat shield.

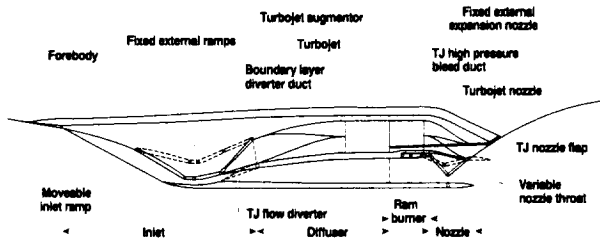

Figure 5. Propulsion system schematic (ref. 2).

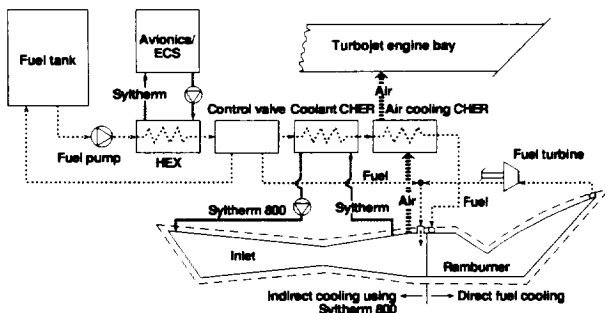

Figure 6. Thermal management system (ref. 2).

Power for the fuel pump and other aircraft systems requirements are derived from the turbine shaft while the turbojet is operating and from a fuel expansion turbine (figure 6) when the ramjet is operating. Both sources are available during transition. The power generated by the fuel turbine is much greater than the power needed to drive the fuel pump during Mach 5 cruise. Engine start and engine-out power is obtained from an auxiliary power unit (APU).

3.1.1.3 Structural/Material/Tank System

The Mach 5 cruise aircraft was designed (ref. 2) as a hot structure with integral tanks lined with insulation and containing flexible fuel cells. Honeycomb sandwich panels of a monolithic titanium alloy (Ti6242) were selected for airframe skins because they provide a lightweight structural solution (figure 7) requiring only modest ringframes between the major frame and bulkheads. Maximum structural temperatures approach 900°F. Wing and tail leading edges are more severely heated (1,300-1,500°F), so a metal matrix material is used which has silicon carbide fibers in a titanium-aluminide alloy matrix (TMC).

The fuel tank design uses flexible fuel cells within the integral tank. This allows the airframe to be completely assembled before installing the fuel cells. Rigid insulation (figure 7) was used to protect the fuel cells from the hot airframe.

3.1.1.4 Other Systems

Certain systems that are common to several classes of hypersonic aircraft such as avionics and actuation will be deferred to example baselines to come later herein (sections 3.2.1 and 4.1.1).

3.1.1.5 Challenges

Developing a turboramjet and ramjet powerplant for a hydrocarbon-fueled hypersonic airplane is the first challenge. Integrating in a viable arrangement that will accommodate an efficient inlet system and allow a smooth transition from the turbojet to the ramjet is a close second. Given the sensitivity of inlet bleed on range, designing high performance inlet systems with minimum bleed is a challenge worth undertaking.

Also, the inlet/diffuser system presented (figure 5) with its internal flow diverter (splitter) to control engine flows is very long. The engine nacelle could be shortened by using a split two-inlet system; whether or not the performance could be maintained is the question.

One of the biggest challenges for the thermal management system is cooling of the aircraft during high-speed decelera-

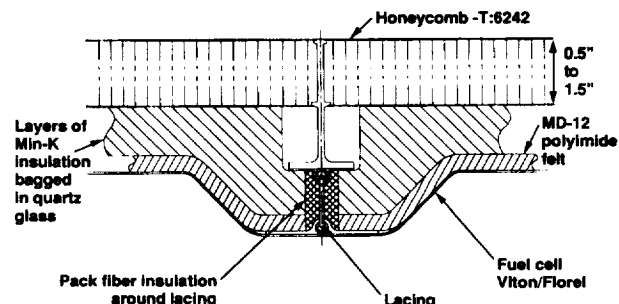

Figure 7. Structural/tank wall concept (ref. 2).

tion. Thrust must be reduced which results in less fuel needed for combustion, while the heat loads remain high. A layer of air could act as film cooling near the wall while combustion is restricted to the center core of the ramjet combustor.

3.2 Hydrogen Fueled Airplanes ($M > 8$)

Hydrogen-fueled airplane designs offer more options in engine integration architecture than their hydrocarbon fueled counterparts, which again centers on whether the engine integration embodies a single duct, a duct and one-half or a two-duct approach. The single duct would be an ejector ramjet/ scramjet in which the ejector rocket motors operate on liquid oxygen/liquid hydrogen (LOX/LH₂) or gaseous oxygen/ gaseous hydrogen (GOX/GH₂) propellant. Remove the LOX tank and add a Liquid Air Cycle Engine (LACE) system, for which the ejector operates on LAIR/LH₂, and the duct and one-half approach results since the LACE system requires an auxiliary inlet. Remove the LACE system and add a turbooramjet and the two duct system emerges since the turbooramjet requires both an inlet and an exhaust nozzle.

3.2.1 Example Baseline

A design data base exists for an underslung turbooramjet/dual mode scramjet over/under integrated Mach 10 cruise vehicle (figure 8), namely NASA's Dual-Fuel Airbreathing Hypersonic Vehicle Study (ref. 3 and 4), in which an all-hydrogen-fueled design option was examined. This all hydrogen version was selected as the reference with respect to system architectures for hydrogen-fueled cruise airplane designs providing continuity with the two-duct hydrocarbon-fueled example. Accommodating a payload of 10,000 lbs. in a 2,000 ft³ payload bay, the range of the Mach 10 reference airplane is approximately 10,000 nm. in a 200 ft. long vehicle with a TOGW less than 500,000 lbs.

3.2.1.1 Propulsion

The airbreathing propulsion system (ref. 5, 6, and 7) operates in three speed regimes (low, $M = 0$ to 4; mid, $M = 4$ to 4.5; and high speed, $M = 4.5$ to 10) with a distinct engine and/or engine combination for each as depicted in figure 9. During low and mid-speed the turbooramjets (Air Core Enhanced Turbooramjet (AceTR) for this study) operate at full power to provide acceleration thrust; the turbooramjets were sized such that no external burning was required to augment thrust production at transonic speeds. The ramjet/scramjet engine remains shut-down/closed-off in the low-speed regime. Engine close-off is achieved by upward rotation of the inlet and nozzle cowl flaps until each flap contacts its respective



Figure 8. Mach 10 aircraft (ref. 3).

upper bodyside surfaces. From Mach 4.0 to 4.5 both the turbooramjet and the ramjet/scramjet systems are functioning to provide uninterrupted maximum thrust during the transition from turbojet to ramjet/scramjet operation. During high speed operation, the turbooramjets are shutdown/closed-off and the ramjet/scramjet is used to accelerate to and cruise at Mach 10.

At the completion of the Mach 10 cruise segment the scramjet is shutdown/closed-off. The vehicle then descends unpowered from Mach 10 to approximately Mach 0.8/30K feet altitude, where the low-speed inlet and nozzle are reopened and the turbooramjets are airstarted. The turbooramjets then operate at partial power for the remainder of the mission including subsonic cruise and landing.

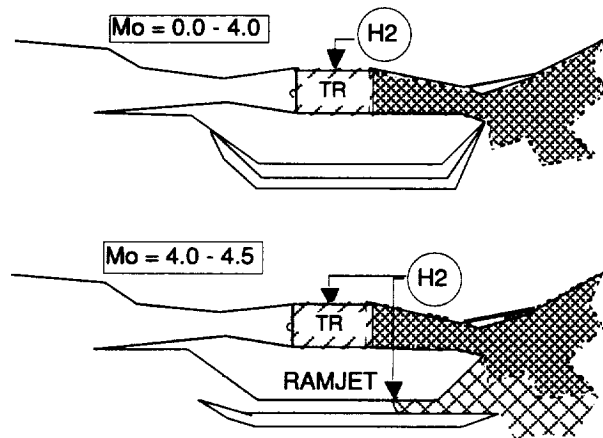

Figure 9a. Propulsion system operation (initial acceleration).

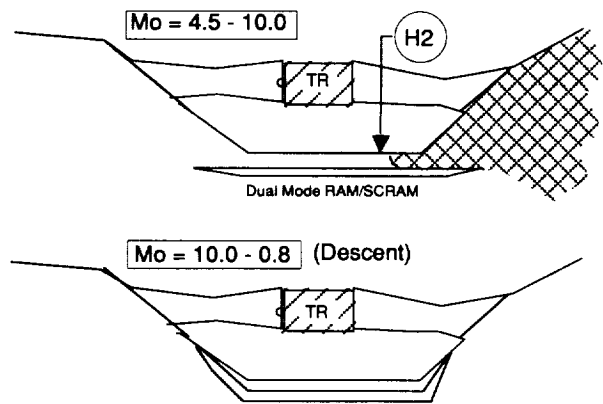

Figure 9b. Propulsion system operation (high speed acceleration, cruise, descent).

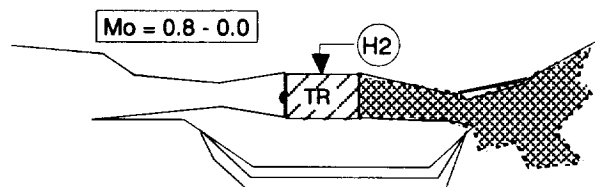

Figure 9c. Propulsion system operation (low speed cruise and landing).

3.2.1.2 Thermal Management System

An overview of the thermal management approach (ref. 6) for the Mach 10, hydrogen-fueled cruise vehicle is shown in figure 10. Fuel is routed from the aircraft's main fuel tank through heat exchangers with a secondary cooling loop, to the actively-cooled fuselage leading edge, and then to the propulsion active cooling system including the internal propulsion flowpath and the initial part of the external nozzle, and finally out into the combustor. The hydrogen boil-off handles most of the airframe aerodynamic heat loads. The propulsion system is cooled by the fuel via non-integral heat exchangers mounted to the structure on the internal heated surfaces of the engines; the system layout is shown in Figure 11 including the hydrogen flow network for providing hot hydrogen flow back from the combustor heat exchanger to the turbines for operating boost pumps, main fuel pump and auxiliary power unit. The subsystems are cooled by the fuel via coldplate heat exchangers; the layout is shown in figure 12 where Ethylene Glycol/Water is used in the second coolant loop between the hydrogen heat exchangers off the main tank and the subsystems.

3.2.1.3 Fuel Supply System

The hydrogen fuel system for the Mach 10 cruise vehicle (ref. 6) was designed for horizontal takeoff and aircraft-type operability. The forward and aft tankage were interconnected among themselves to form functionally individual tanks. Each forward and aft tank has separate fill loops to allow for tankage to be at different elevations and filled to satisfy center-of-gravity requirements. Each tank has a self-contained chill system which consists of spray bars in which hydrogen is circulated to keep the tank near equilibrium. The tanks vent to a ground disposal system when filling and allow free venting during flight or ground maneuver operations. The system includes all composite valves, all electric valves/actuators and zero-push boost pumps. The boost pump will allow continuous tank drainage. The tank bodies and actuator housings are made of graphite composite. The feedlines are composite construction with stainless steel bellows and titanium

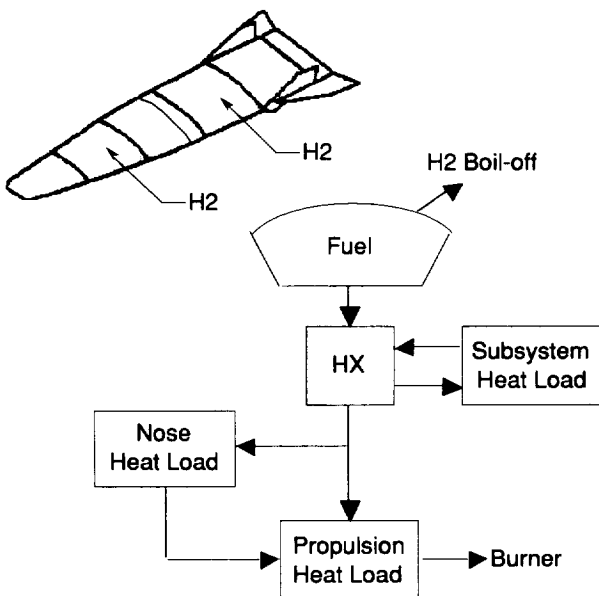

Figure 10. Mach 10 cruise vehicle thermal management approach (ref. 6).

restraints bonded to the composite lines to provide flexibility (foam insulation is used on all feedlines). The fuel system is designed with fail safe redundancy.

The initial fuel system for the hydrogen vehicle in the Mach 10 global reach airplane design study was liquid hydrogen because the design was simpler for both flight system and ground support compared to a slush hydrogen-fuel system. However, slush hydrogen would allow the fuel system to operate at a much lower tank pressure as illustrated in figure 13. During design refinement, a trade study was conducted to evaluate the advantage of a slush hydrogen fuel system. The boil-off of two liquid

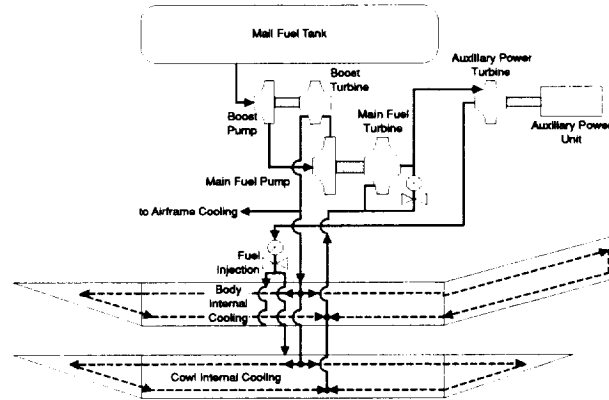

Figure 11. Mach 10 cruise vehicle propulsion cooling design concept.

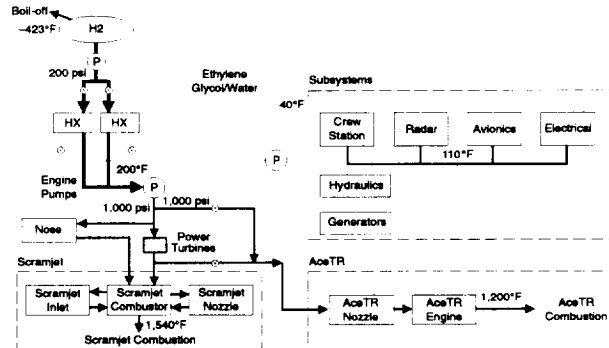

Figure 12. Mach 10 cruise vehicle thermal management system design concept (simplified version of dual-fuel system in ref. 6).

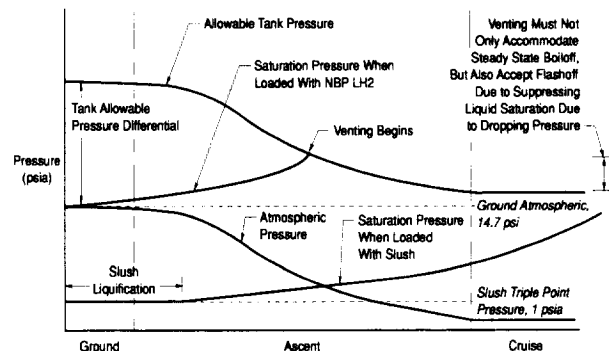

Figure 13. Difference in liquid and slush hydrogen fuel system thermodynamics. (ref. 6).

hydrogen fuel tanks at 20 or 30 psid and two slush hydrogen tanks at 5 or 20 psid were analyzed. The liquid hydrogen boil-off is small during ground hold after the ground support equipment disconnect. However, it accumulates much more rapidly during both outbound and the return flight. As a result, the slush hydrogen fuel system has much lower total boil-off as shown in figure 14. A 50% slush hydrogen fuel also provides a 15% density increase compared to normal boiling point liquid hydrogen and an added heat sink capacity of 110 Btu/lb.

For a slush hydrogen fuel system design, slush return manifold and lines must be added to melt slush in the tank to prevent clogging in inlet lines during flight. A fill return system was added to recirculate fill slush and densify propellant. The schematic of the slush hydrogen fuel system design selected as a baseline herein is presented in figure 15.

3.2.1.4 Pressurization and Purge Systems

The pressurization system (helium) provides active control of cryogenic hydrogen/slush supercritical storage. The slush hydrogen fuel system requires initial pressurization only. The liquid oxygen APU (auxiliary power unit) supply tank requires continuous pressurization. The slush hydrogen tank exterior and vehicle cavity need to be continuously purged for safety during ascent and descent below 100,000 feet altitude. The hydrogen vent also requires purge. The purge and pressurization system uses technology similar to the hydrogen-fuel system, with all composite valves and feed lines, and all-electric valve actuation. It was designed with fail safe redundancy.

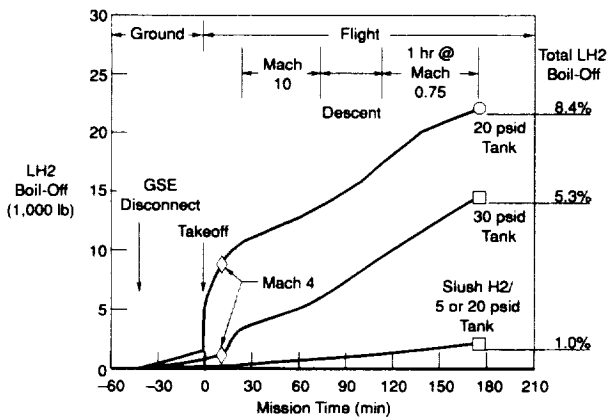

Figure 14. Boil-off comparison of liquid and slush hydrogen fuel system (ref. 6).

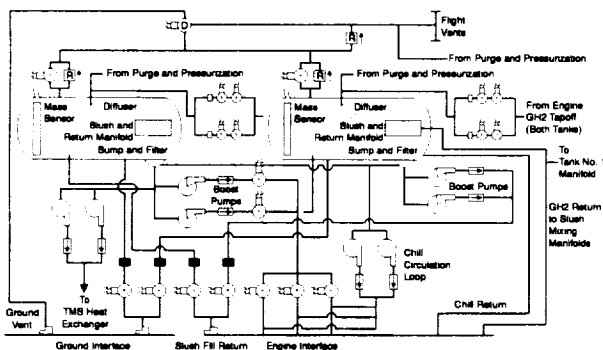

Figure 15. Mach 10 cruise vehicle slush hydrogen fuel system schematic (ref. 6).

3.2.1.5 Vehicle Management System

The Vehicle Management System (VMS) design concept is based on the Versatile Flight Control System (VFCS) and is a fly-by-light (FBL) configuration. Quadruplex FBL architecture is the design approach. The major functions of the avionics are: (1) store mission information, (2) provide crew with situation awareness (engine status, terrain and star maps, GPS, etc.), and (3) provide communication capability, threat warnings, air data and radar information, aircraft subsystem status and maintenance information. The mission critical portions of the avionics are dual redundant; the remainder is single channel. All buses are fiber-optic.

3.2.1.6 Airframe Structure/TPS System

The airframe for the Mach 10 cruise airplane (ref. 7) is a cold structure with an integral slush hydrogen tank (figure 16). A cold, integral conformal graphite-epoxy (Gr/Ep) tank design is used since the maximum pressure differential for the slush hydrogen tank is only 5 psi. Graphite composite constitutes the remainder of the fuselage structure. There is tungsten in the nose area for ballast and the all-moveable wings are hot structure (titanium matrix composites, TMC). Cryogenic foam insulation is bonded to the outside of the tank using a chemical bond between the polyimide and graphite epoxy. High temperature insulation with a heat shield is then attached to stand-off posts which penetrate the foam and are secured to the GR/EP tank.

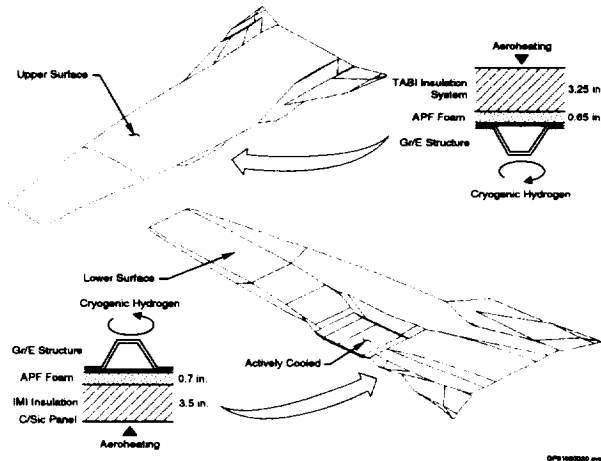

Figure 16a. Fuselage TPS insulation requirements for cold structure vehicle with typical dimensions (ref. 7).

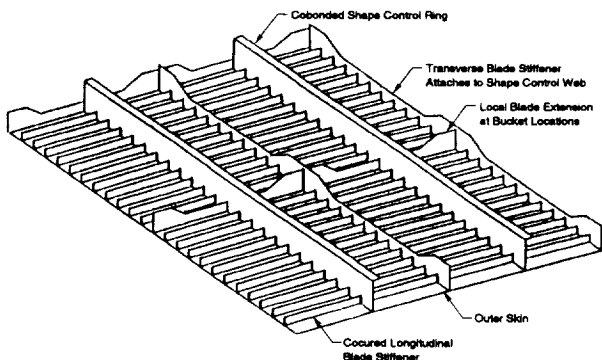

Figure 16b. Trimetric of cold skin with integral fuel tank construction (ref. 7).

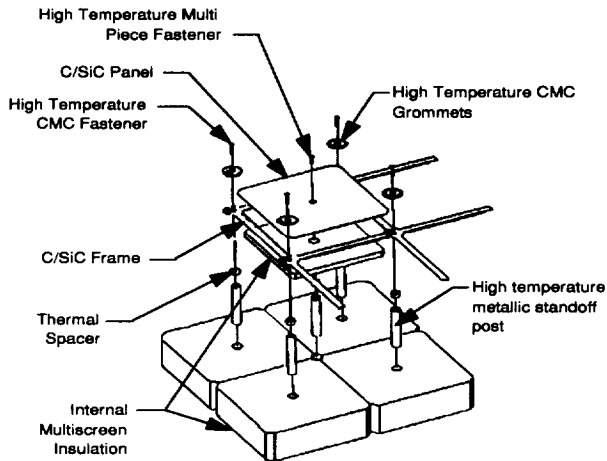

Figure 17. Advanced TPS (ref. 6).

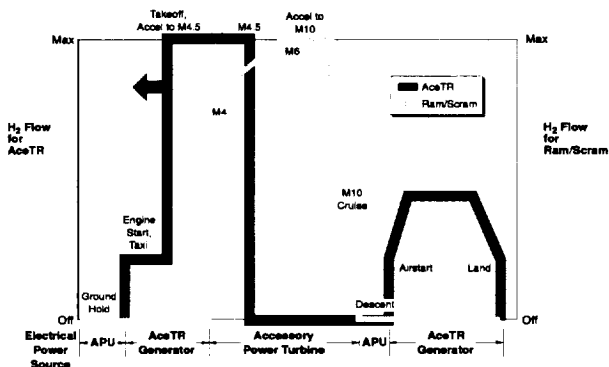

Figure 18. Electrical power source and hydrogen flow rate as a function of use.

The flowpath (lower surface) TPS assembly (ref. 6) is shown in figure 17. It consists of a 60-mil external carbon/silicon-carbide (C/SiC) panel and frame, CMC/metallic (ceramic matrix composites) standoff attachment post, staggered Internal Multiscreen Insulation (IMI), integrated purge channel and APF insulation. The addition of purge resulted in a weight savings for the TPS while providing many operational advantages. A Tailorable Advanced Blanket Insulation (TABI) type TPS was found to be better for tank locations on the top of the vehicle. TABI consists of woven fiber mat with triangular alumina foam prisms encased inside (ref. 6).

3.2.1.7 Leading Edge Systems

Based on work done for the National Aero-Space Plane (NASP) program, the actively-cooled leading edges used on the engine are specified to be 0.1" radius (ref. 4); the vehicle and wing leading edges have a 0.2" radius. The engine cowl, sidewall and vehicle leading edges are actively cooled. The engine cowl leading edge is a particularly difficult cooling problem because it would be exposed to severe heating if the bow shock impinges on the cowl-lip. The challenge is to use materials with a combination of high conductivity and high temperature capability which can be adequately cooled to survive this heating requirement. A platelet architecture was selected for the baseline design using a copper alloy material.

The wing leading edges are made of ceramic matrix composites such as zirconium diboride or coated carbon/carbon. High temperature ceramic composite leading edges are currently being tested by the Air Force under the HyTech Program and results should be available in 1997 (ref. 8).

3.2.1.8 Power Generation

The power generation concept has two sources of power to drive one generator. Figure 18 shows which power source is driving the generator as a function of mission. When neither engine is operating, the APU (figure 11) is used to power the generator with one exception. When the vehicle is operating above Mach 4 the cooling loads generate enough gas to spin the accessory power turbine, which in turn spins the associated starter/generator.

3.2.1.9 Actuation

Actuator sizes and types were selected to meet the mission dynamics and static loads requirements. Power requirements dictate that the major portion of the actuator be hydraulic. Control surfaces, landing gear extension and nose gear steering have hydraulic actuators with electrically driven motor pumps. All other actuators are electromechanical. A typical actuator block diagram is presented in figure 19.

3.2.1.10 Challenge

The challenges for developing the hydrogen-fueled over/under type of hypersonic airbreathing propulsion system are similar to that for the lower speed, hydrocarbon-fueled example baseline. A reasonably high performance, high thrust-to-weight turboramjet is required along with a ramjet/scramjet or dual-mode ramjet. These two engine systems must be integrated together in both a viable vehicle flowpath configuration and a viable mechanical design with actuation/seal systems that allow variable geometry operations over a broad Mach range with engine mode transition.

Due to the relatively long cruises at high speed the thermal protection system (TPS) and the thermal management system (TMS) design must be analyzed as an integrated system and optimized interactively. The thermal management system must provide adequate cooling for the dual-mode combined engine structure/subsystems, the airframe leading edges, crew station, avionics, radar, hydraulics, and the electrical power. A challenge in developing the thermal management system is

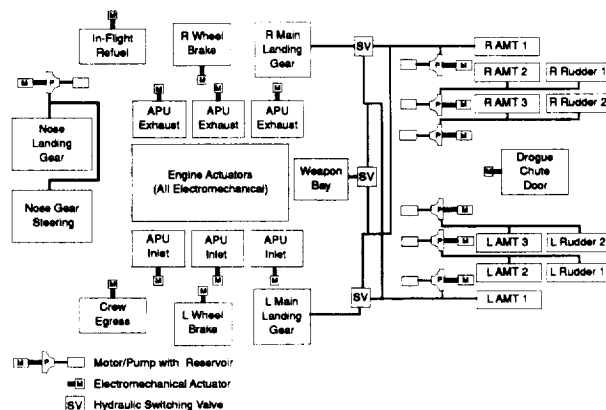

Figure 19. Actuation block diagram (generic).

the direct cooling non-integral heat exchanger for the engine; they must be reliable and allow high fuel injection temperatures without surface oxidation at a reasonable weight.

The fuel supply system presents considerable development challenges including all composite valves, feedlines and slush return manifold. Perhaps the biggest challenge is to overcome negative paradigms with respect to the use of slush hydrogen.

In structures/tankage, the challenge is to develop conformal, integral, graphite-epoxy, slush-hydrogen tankage; graphite-composite fuselage-structure and IMI TPS system with integrated purge. Also, the wing box and airframe interface for the rotating TMC wings require some development.

In avionics, the challenge is to design/develop the concept to meet the specific mission reliability requirements.

3.2.2 Ejector Ramjet/Ram-Scramjet (1.0 ducts)

This is a single propulsion duct machine and therefore offers the least engine/airframe integration challenges. Its propulsion system consists of a LOX/GH2 ejector ramjet system that operates from takeoff to Mach 2.5 or 3 where the ejector system is shut down and full ramjet mode takes over. The challenge is to design a more efficient ejector ramjet without significant engine weight increases. This hinges, to some degree, on whether or not mixing and diffusion can be allowed to occur simultaneously; the simultaneous approach would provide more performance potential, but could provide added choking risk.

The low specific impulse potential of the LOX/GH2 ejector ramjet and the added weight (high density) of the LOX may provide a rather unattractive airplane from a range vs. TOGW and loiter perspective.

3.2.3 Liquid Air Cycle Engine Ejector Ramjet Ram-Scramjet (1.5 ducts)

The Liquid Air Cycle Engine (LACE) system with its auxiliary inlet in the over position and the ram-scramjet in the under position is a duct and one-half system; the LACE requires no exhaust duct...the liquid air (LAIR) is supplied to the ejector stagnation chamber via plumbing. This system

Advantages

- Light weight
- Small volume
- Low pressure drop
- High thermal efficiency
- Potentially low cost

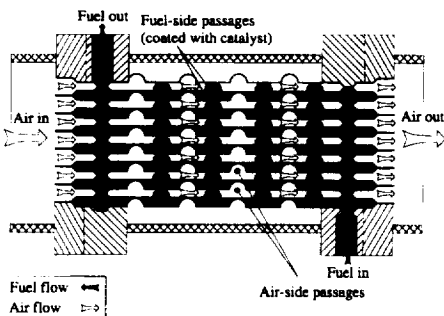

Applications

- Catalytic Heat Exchanger Reactors
- H2 to LOX Heat Exchanger
- Cool air supply for APU
- Cryogenic Heat Exchangers
- Electronics Thermal Management

Figure 20. Dimpled foil heat exchanger technology for hypersonic vehicles (ref. 1).

offers a much improved specific impulse potential over that of its lower derivative, the LOX/GH2 ejector ramjet. The challenge is to develop efficient, light weight heat exchangers for use in LACE architectures and to manufacture a reliable leak-proof system or one in which the leaks could be managed. The dimple foil design shown in figure 20 offers an order of magnitude reduction in weight over that of the conventional tube-bank-manifold approach for the same heat transfer capacity.

4. ACCESS TO SPACE

Access to Space is and will remain a strategic issue for leading nations. However, this does not mean that concern for cost will be disregarded. In the context of international competition, cost reductions are and will be mandatory to create new business.

Although the future prospects of expendables remain high in terms of cost reduction as reflected in simplification of the vehicles and their operations, in scalability to fit the payload/orbital-destination market and in multiplicity of launch options, their potential appears limited below that of reusable launchers in terms of cost-per-pound-to-orbit. Reusability with reliable systems that provide substantial cycle-life seems to be the only way to achieve dramatic cost reductions (ref. 9).

Will reusable launch vehicles pave the way to a dramatic cost reduction in access to space and in so doing, create a new business? Will they generate new financial and operational approaches? Will they require new infrastructures? System studies are mandatory to analyze these issues and focus on the related technology development programs. A coarse vehicle matrix for Access to Space is presented in figure 21. Only single-stage-to-orbit (SSTO) and two-stage-to-orbit (TSTO) vehicles are included in order to contain the discussion.

4.1 Single-Stage-To-Orbit (SSTO) Vehicles

SSTO is the aspiration of the astronautics community: only one vehicle to develop, manufacture, and operate. The feasibility, however, depends on the development of necessary technologies for required dry mass fraction with built in margins that will provide reliable systems with favorable cycle life.

The SSTO systems discussion will be segmented on the propulsion systems, i.e., airbreathing and rocket powered systems.

4.1.1 Airbreathing SSTO Vehicles

Airbreathing SSTO vehicles offer mission flexibility in terms of favorable launch window, launch offset and cross range capabilities. Discussion of SSTO airbreathing vehicles will concentrate on horizontal takeoff/landing systems since this is where most of the emphasis has been placed in recent studies

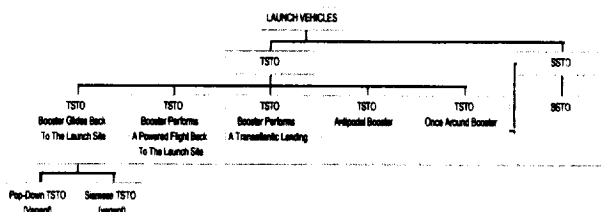

Figure 21. Configuration matrix for SSTO and TSTO vehicles.

(ref. 1, 10, 11 and 12) and it provides continuity with airplanes. Also, there are compelling reasons for horizontal takeoff/landing airbreathing systems such as gradual step and check engine startup and shutdown, abort during and shortly after takeoff, etc. It will be assumed that the airbreathing portion of the trajectory extends beyond Mach 8 and thus requires a scramjet since rocket-initiation/pull-up at Mach 8 or below (ramjet operations) would probably require dropping takeoff gears (trolley, etc.) at lift off and thus would not be categorized as a classic SSTO.

A definitive design study was performed on an SSTO airbreathing propelled orbital vehicle with rocket propulsion augmentation in NASA's Access to Space study activities (ref. 13 and 14; Option III Team). A credible design was established (ref. 15), but by no means an optimum. This design (figure 22) provides a reference representing system architecture for airbreathing SSTO vehicles; it was developed by the Langley Research Center's Systems Analysis Office in 1993.

4.1.1.1 Example Baseline

The airbreathing SSTO reference vehicle (figure 22) was designed to carry 25,000 lbs. of payload in a 15' x 15' x 30' rectangular payload bay to an orbit of 220 nm, 51.6° inclination, then dock with a hypothetical space station for delivery of the payload (ref. 15). It had a 15% weight growth margin, a 5-minute launch window, and an ascent delta velocity margin of 1%. The takeoff gross weight sized for the closed mission was 917,000 lbs., the dry weight was 239,000 lbs., and the length was 200 ft.

4.1.1.1.1 Architecture

The baseline design (ref. 13) as shown in figure 22 consists of:

- A wedge-shaped forebody profile, spatula-shaped forebody planform, lifting-body configuration with all moving horizontal tails, twin vertical tails with rudders, and trailing edge body flaps.
- Underslung, 2-D airbreathing engine nacelle for which the vehicle forebody serves as a precompression surface and the aftbody as a high expansion ratio nozzle; two engine systems with 130K lbs. of thrust each at takeoff.
- Linear modular, aerospike rocket engine at the trailing edge; two engine systems with 117K lbs. of thrust each at takeoff.
- Slush hydrogen fuel (SH₂) and Liquid Oxygen oxidizer (LOX) propellant (about a 50/50 split by weight).
- Actively cooled leading edges (fuselage spatula-shaped region and engine cowl); actively cooled, non-integral panels in engine.
- A 15' x 15' x 30' rectangular payload bay located in the

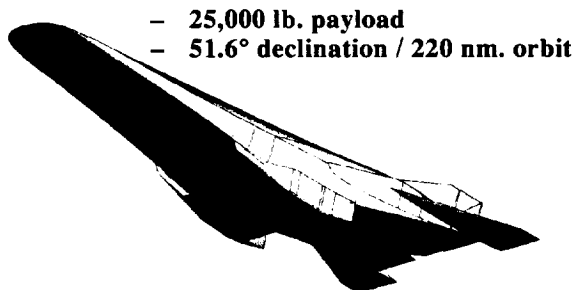

Figure 22. Reference airbreathing SSTO vehicle (ref. 13).

- vehicle mid section with two "shuttle-like" doors that swing
- A crew station adjacent to the payload bay with access/escape from the vehicle topside and conduit to the payload bay.
- Two 6-wheel main landing gears; one nose gear (two wheels).
- Baseline vehicle airframe structure/tank/thermal protection systems (TPS).
 - Graphite/epoxy (Gr/Ep) integral, I-stiffened, conformal slush hydrogen (SH₂) tank
 - Aluminum/Lithium (Al/Li) non-integral, multilobe liquid oxygen (LOX) tanks
 - Gr/Ep shell structure fore and aft of integral tank; Titanium Matrix Composites (TMC), Silicon carbide/beta 21s titanium all moving horizontal controls and twin verticals/rudder with Carbon/Silicon Carbide (C/SiC) TPS over portions exceeding 1,960°R; carbon-carbon (C/C) leading and trailing edges
 - Fibrous Refractory Composite Insulation (FRCI-12) over Rohacell insulation on windward surface and Tailorable Advanced Blanket (TABI) over Rohacell insulation on leeward surface.

4.1.1.1.2 Trajectory/Engine Modes

The airbreathing corridor to Mach 25 and the engine mode changes experienced in this acceleration process also characterize this aerospace plane. A representative ascent trajectory (ref. 13) for the SSTO vehicle is presented in figure 23 including indicators for propulsion mode events. Most of the airbreathing propelled ascent is along a high dynamic pressure isobar (2150 psf). Takeoff and transonic ascension are accomplished with the low-speed system and external rocket system performing simultaneously. The rocket is switched off at Mach 2. Transition to the scramjet mode begins at Mach 6 with the full scramjet mode in operation by Mach 7.5. Departure from the isobar above Mach 15 signals the onset of LOX augmentation through the scramjet and the activation of the external rocket system as indicated in figure 23. Scramjet main engine cutoff (MECO) is at Mach 24. Even though the external rocket system has essentially the same thrust at takeoff as the airbreathing engine, the airbreathing flowpath provides 83% of the total ascent energy.

4.1.1.1.3 Thermal Management

The cooling concept of the airbreathing engine for this refer-

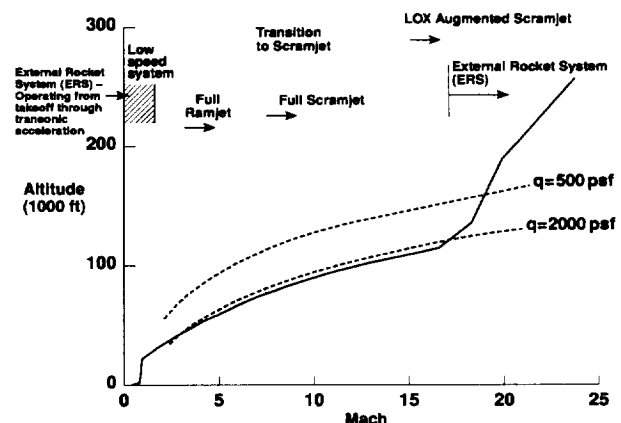

Figure 23. Representative ascent trajectory (ref. 15).

ence SSTO is a cold structure (ref. 15) with mostly nonintegral, actively-cooled heat exchangers. Cryogenic hydrogen fuel is the coolant. Slush hydrogen is stored in the tank at 20 psig and 25°R. It is pumped to 5,500 psi and 60°R before circulating through the cooling panels, then through a turbine to drive the pump, back into the cooling network again, and out into the combustor. The heat exchangers were sized at Mach 15 conditions, where the heat loads are greatest. The cooling panel network was designed to deliver hot hydrogen to the injectors.

4.1.1.1.4 Subsystems

The majority of the subsystems are highly integrated with each other. The individual subsystems are (ref. 15): (1) active vehicle thermal control system (AVTCS), (2) environmental control and life support system (ECLSS), (3) electrical power generation and conversion system (EPG&C), (4) hydraulic and actuation, (5) auxiliary power unit (APU), (6) reaction control system (RCS), (7) fuel system, (8) oxidizer system, (9) vehicle pressurization, purge and drain system (VPP&D), and (10) avionics.

The AVTCS will be required to handle both cryogenic and hot hydrogen within the same fluid network. Active cooling is provided on the external nozzle, the airframe inlet ramp, engine systems, and the external rocket system. The active cooling panels will deliver hot hydrogen to the engine. Because fuel is used as the coolant, a fail-safe control system is being used. The ECLSS uses standard cryogenic hydrogen control devices, modified for low weight/volume, and provides an operation working environment for the crew. It also provides cooling for the vehicle management system, instrumentation, and hydraulic fluids.

The EPG&C consists of a number of 40 kW 270 VDC fuel cell assemblies. The fuel cells come from existing technology developed for the Space Shuttle program. They use hydrogen and oxygen and provide electrical power primarily for on-orbit duty, but are also used for avionics. APU's provide the hydraulic power for the actuators that control the aero-surfaces and the landing gear. The APU system is derived from an existing Space Shuttle system. It is driven by a dual mode, gas generator expander cycle turbine using hot gas temperature differential which is required to prevent overheating of the material, thereby making the APU power requirements virtually "free" during ascent. The hydraulic system utilizes a conventional hydraulic fluid system that operates at 8,000 psia. Hydraulic fluid cooling heat exchangers dump heat directly into a hydrogen fuel system that provides for the gasification of LH2 and LOX for use in the RCS. The RCS is a previously-developed rocket assembly.

The fuel system is a cryogenic fluid delivery system that supplies LH2 from the vehicle's tanks to the engine turbopumps and actively-cooled panels using a series of boost pumps. Because the hydrogen fuel in the tanks was sub-cooled to a slush condition, separate spray and mixing systems in the tanks are required to continually circulate the hydrogen so that it does not stratify; the ullage is kept at the same temperature as the fuel.

The oxidizer system provides LOX to the engine and external rocket system and is composed of both high and low pressure turbopumps. These pumps are used only to supply LOX to

the main scramjet engine; the external rocket system has its own turbomachinery.

The VPP&D is required to provide helium for tank pressurization, vehicle cavity purge and repressurization, and pneumatic actuation. Helium is stored at 25°R within the hydrogen fuel tank.

The avionics is based on a proven quad-redundant architecture using ADA software and dual-fiber optics busses which is intended to provide for autonomous control.

4.1.1.1.5 Challenges

The system challenges extend from the actively-cooled airframe and engine cowl leading edges to the linear aerospike rocket engine at the airframe trailing edge. Some of the most critical items that are essentially the same as for the Mach 10 cruise baseline example are: the graphite/epoxy integral fuel (SH2) tank and TPS system, the ramjet/scramjet engine with mechanisms for mode transition; and the actively-cooled engine non-integral heat exchangers that allow fuel injection temperatures of 2,000°R. An 8,000 psia hydraulic system is also required, as is a health monitoring/management system for the entire vehicle. Optimization of the reference design to reduce dry weight and cost is in progress at LaRC.

4.1.2 Rocket-Powered SSTO Vehicles

Because of the enhanced propellant load due to on-board LOX as the oxidizer (LH2 as fuel), rocket-powered SSTO's must be vertical takeoff machines (launch assist is not being considered). Also, only horizontal landing is being considered to contain the scope.

The case for the SSTO rocket launch vehicle is made in reference 16 in which mass fraction, margin, minuscule payload, and sensitivity concerns are addressed and shown to be ameliorated with cumulative technology advancements.

4.1.2.1 Example Baseline

A reusable, rocket-powered, SSTO launch vehicle was designed (ref. 17 and 18) as a part of the Advanced Manned Launch System (AMLS) study in NASA Langley's Vehicle Analysis Branch and is an appropriate reference vehicle. The design reference mission for the AMLS single-stage vehicle is delivery and return of a 20,000 lb. payload and 2 crew to an international space station (51.6°, 220 nm).

4.1.2.1.2 Architecture

The vehicle design (ref. 17) is shown in figure 24. The payload bay is 15 ft. in diameter and 30 ft. long and located between an aft liquid hydrogen (LH2) tank and a forward liquid oxygen (LOX) tank. The normal-boiling-point LH2 and LOX propellants are contained in integral, reusable cryogenic tanks. On board propellants would provide an incremental velocity (ΔV) of 1100 ft./sec. following launch insertion into a 50 x 100 nm orbit. The design employs wing tip fins for directional control. The crew cabin is located on top of the vehicle. An airlock located aft of the crew cabin provides access to the cross-wise canister payload bay and to the space station through a hatch on top.

The liftoff thrust-to-weight (T/W) of the SSTO is 1.22 (ref. 17).

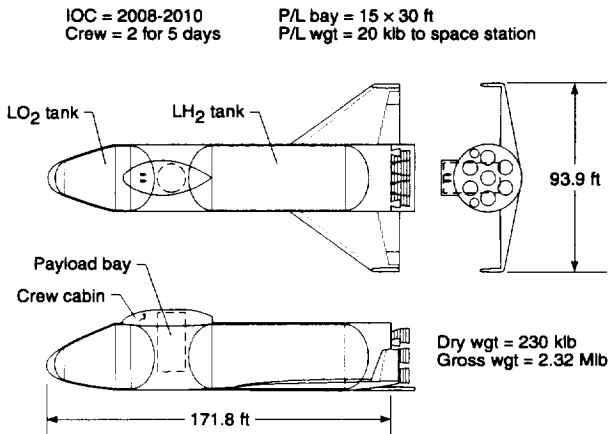

Figure 24. Reference rocket-powered SSTO configuration (ref. 17).

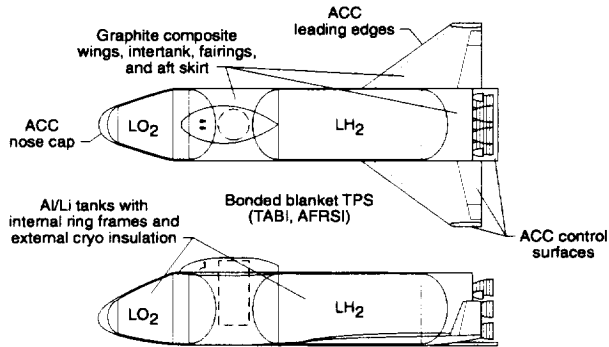

Figure 25. Reference SSTO vehicle materials (ref. 17).

The vehicle dry weight is 230,000 lbs., and the gross weight is 2,320,000 lbs. (figure 24).

4.1.2.1.3 Reference Systems/Technologies

The reference AMLS SSTO has seven SSME-derivative engines that are gimballed for vehicle control during ascent and abort (ref. 18); the performance characteristics of one of these engines are summarized in Table 1. The SSME-derivative engine differs from the current SSME in a number of ways (ref. 18). Extended-life, high-pressure turbopumps are used with hydrostatic bearings. Electromechanical actuators are used for gimbals and valves. Other improvements include integrated health monitoring, a Block II controller, and a two-duct hot gas manifold.

The major materials and structural technologies assumed for the AMLS SSTO vehicle (ref. 17) are summarized in figure 25. The SSTO vehicle employs graphite composite wings, intertank, nose region, fairings and aft skirt which all act as carrier panels for a ceramic blanket TPS on most windward and leeward surfaces and for an advanced carbon-carbon (ACC) TPS on the vehicle nose and leading edges (ref. 17). All aerodynamic control surfaces are of an ACC hot structure design. The integral hydrogen and oxygen tanks are constructed of Al-Li 2095 and utilize external, closed-cell foam insulation. The thrust structure also utilizes Al-Li 2095 and graphite composite elements (ref. 18).

4.1.2.1.4 Challenges

The challenge is the maturation of technologies to enable the design of a viable, affordable SSTO rocket powered vehicle and decrease the operational complexity and empty weight of the vehicle (ref. 17 and 18). More advanced technologies would enable the design of an SSTO vehicle that is less sensitive to changes in engine performance parameters. The cumulative effect of employing a number of moderate technology advancements over STS technologies (ref. 17) is shown in figure 26. Additional technology advances over those assumed for the reference SSTO could enhance the design as shown in figure 27. These technology advancements could be traded for increased vehicle design margins and reduced sensitivities.

4.2 Two-Stage-to-Orbit (TSTO) Vehicles

For TSTO vehicles, technology requirements are reduced relative to SSTO vehicles; they require only current or near-term technologies. Also, they are less sensitive to dry weight growth. They allow the proration of the ascent energy (delta velocity) among the stages (booster and orbiter). However, TSTO systems lead to the development, manufacture, and operation of the two vehicles (in fact, three: the composite, the booster and the orbiter).

Since the design of access to space vehicles is influenced to a major extent by propulsion systems and propulsion integra-

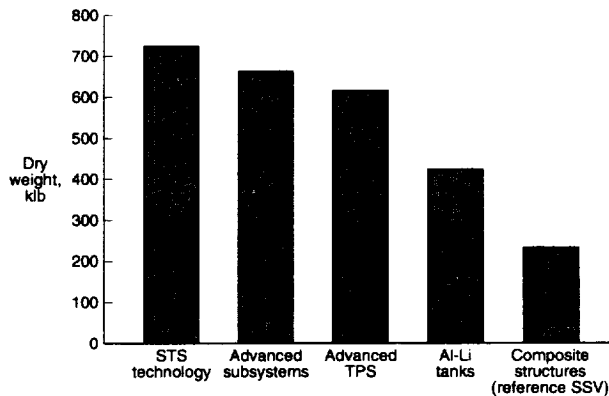

Figure 26. Cumulative effect of technology evolution from STS (ref. 17).

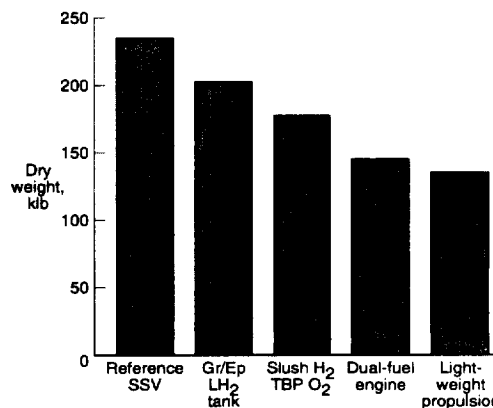

Figure 27. Cumulative effect of enhancing technologies on rocket-powered vehicle (ref. 17).

tion architectures, the TSTO vehicles will be categorized according to propulsion systems. A coarse TSTO classification is given in figure 28 which has categories for airbreathing boosters and rocket powered boosters as well as combination powered orbiters and rocket powered orbiters. The airbreathing boosters are further divided with respect to ramjet ($M < 6$) and scramjet ($M > 6$) propulsion systems. The remainder of the discussion centers mainly on the boosters as they constitute the greatest challenge—from a systems, operations, and cost perspective.

4.2.1 TSTO Vehicles With Airbreathing Boosters / Rocket Powered Orbiters

The focus is on a horizontal take-off and landing (HTOL) launch vehicle. The advantage is more versatile basing with airplane like operations, launch offset capability and near-term technology requirements. For launch systems that stage at Mach 6 or below, the booster could be designed with near-term technology. Boosters that stage above Mach 6 would require more advanced technology because of the need for a scramjet and more sophisticated/thicker TPS. With their ability to cruise, airbreathing boosters have the potential to return to viable landing sites, even at the higher staging Mach numbers.

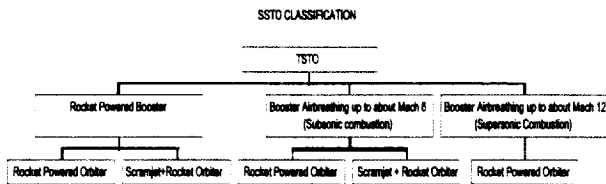

Figure 28. TSTO vehicle classification.

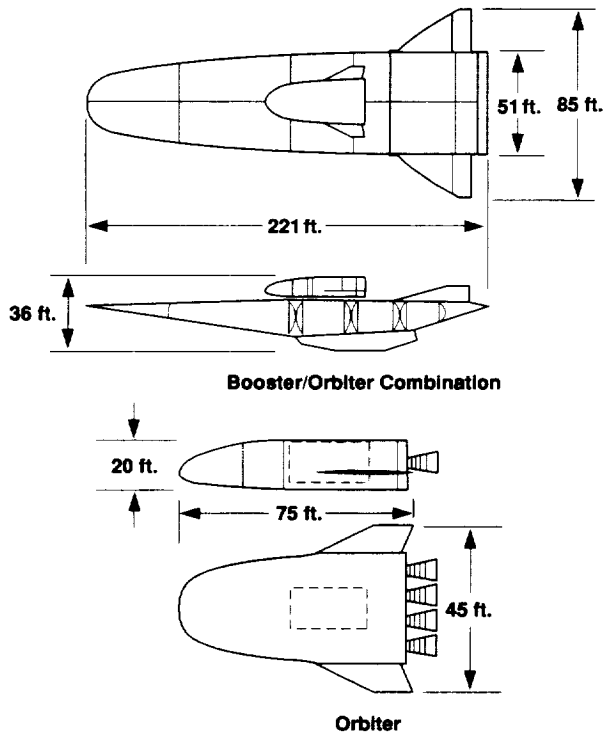

Figure 29. TSTO (airbreather/rocket vehicle characteristics (ref. 13).

4.2.1.1 Example Baseline

The reference vehicle is from NASA's Access to Space Study (ref. 13). The configuration is a horizontal take-off/landing system with a piggy-back orbiter on top of a two-duct, over/under airbreathing booster (figure 29). It stages at Mach 5. The booster propulsion system is a combination of LH2 fueled turbofan jet engines (to $M=2.4$) and ramjets (to $M=5$). The orbiter is rocket powered LH2 fueled. Designed to deliver 25,000 lbs. of payload in a 15' x 15' x 30' bay to a space station at 51.6°, 220nm orbit, the reference 2STO system has a combined take-off gross weight (TOGW) of 800,000 lbs. and dry weight (DW) of 300,000 lbs. The TOGW/DW of the booster and orbiter is 352,000 lbs./252,000 lbs. and 450,000 lbs./52,000 lbs., respectively.

The booster is a lifting-body with a shape very similar to the reference airbreathing SSTO of section 4.1.1.1.3. Both have a spatular airframe leading-edge and rotating wings which also serve as horizontal control surfaces. Both utilize cold integral graphite-epoxy cryogenic tanks (LH2 vs SH2); graphite composite primary structure; and passive, adhesively-bonded TPS, as well as 8,000 psi hydraulic systems.

4.2.1.1.1 Staging

As the staging Mach number is increased, total system gross weight declines (figure 30, ref. 20) because of a more optimal split of the energy content in each stage. Above Mach 6, the booster air-breathing propulsion system would require a ram/scramjet engine. Moving from a Mach 5 to a Mach 10 staging system, the combined gross weight would decrease from 800,000 lbs. to 600,000 lbs. and the combined dry weight would decrease from 300,000 lbs. to 250,000 lbs.

4.2.1.1.2 Challenges

The TSTO reference booster (for Mach 5 staging) requires

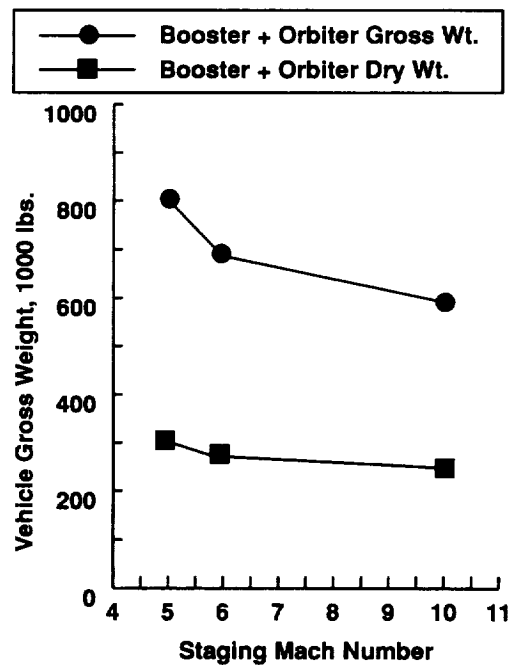

Figure 30. Staging Mach number effect on gross weight (ref. 20).

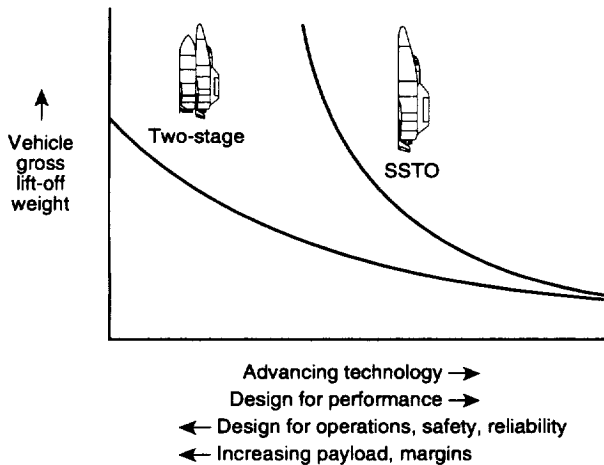

Figure 31. Factors influencing rocket vehicle sizing (ref. 18).

development of a turbojet/ramjet airbreathing propulsion system much like the Mach 5 Waverider airplane of section 3.1.1 except the booster is fueled by LH₂ rather than LHC. Also, a duct and one-half, LACE ejector ramjet could provide an interesting trade, especially for staging at higher Mach numbers ($M > 7$) where transition from a ram to scramjet is required. The structure/material challenges are very similar to the air-breathing SSTO—cold integral graphite-epoxy tanks and graphite composite primary structure—as is the hydraulic system.

The orbiter, as defined in reference 18, would require the development of an expander cycle LOX/LH₂ rocket engine systems. Staging within the atmosphere could be quite a challenge itself. If a pull-up to low dynamic pressure for staging was desirable, then both a tail rocket system and a Reaction Control System (RCS) (for control) would be required for the booster.

4.2.2 TSTO Vehicles with Rocket Powered Boosters/ Rocket Powered Orbiters

TSTO rocket systems are considered primarily because of technology readiness. Also, they retain a gross-weight / dry weight advantage over SSTO rocket systems even at reduced technology levels (figure 31, ref. 21), but the benefits of staging are clearly reduced. For TSTO rocket systems, the recovery of the booster is a major issue since their “fly-back” capability has serious limitations. The criticalness of the recovery issue increases with staging speed, so high staging speed concepts will be considered first.

4.2.2.1 High Staging Speed Concepts (beyond 10,000 ft./sec.)

For these high staging speeds, a relatively even distribution of the ascent energy is achieved between the two stages. Since SSTO vehicles are seldom pure single-stage (for many missions, they need an intelligent upper stage to send their payloads into higher energy orbits), an approach (ref. 22 and 23) is to develop a semi-reusable TSTO, the first stage being targeted to become an SSTO vehicle. Should this SSTO vehicle appear out of reach during its development, either from a cost or technology perspective, the designers would have the following option: reduce the ΔV of the reusable first stage and increase the ΔV of the expendable upper stage. The first stage, unable to go into orbit, would have to perform a once-around flight to land at its launch site, or perhaps land at the Antipodes.

These high staging speed concepts were downselected by Aerospatiale (ref. 23) because the downrange required by the booster is very high (once around) and the ΔV reduction potential is very low, even for high lift-to-drag ratio (L/D) booster configurations. For example, to achieve a ΔV reduction of about 1600 ft./sec. in the booster would require that the hypersonic L/D exceed 5 for the booster to acquire a viable landing site.

Aerospatiale recently downselected another high speed staging concept, Taranis (ref. 24, figure 32, also dubbed “the Transatlantic”), because it raises the question of the independence of access to space activities since the booster landing strips are located outside of the launching country. However, since Taranis exhibits some major advantages such as use of near-term technologies and use of engines derived for the gas generator cycle of Ariane 5, a modified version with an extended range booster (re-boost of the main engines or cruise with turbojets) will be studied. This extended range version would allow a landing on territories belonging to the launching nation.

Having eliminated (downselected) most of the high staging speed TSTO launchers, Aerospatiale’s launch system analyses have been focused on low staging speed concepts (less than 6000 ft./sec.) which allow a rather easy flight back of the booster to its launch base. The main thrust of the work was: (1) study TSTO with staging speed nearing 3,000 ft./sec., (2) assess the Pop-Down concept, (3) assess the Siamese configuration, and (4) assess the interest of using LOX/LHC rather than LOX/LH₂.

4.2.2.2 Staging Speed Nearing 3,000 ft./s

This configuration is envisioned (ref. 23) as a two-stage, parallel-burn, winged, vertical take-off, horizontal landing system. When the launch system reaches a speed of about 3,000 ft./sec., the booster (first stage) is staged and glides back to the launch site runway. This system is an unbalanced configuration with respect to ascent energy having a quite “easy-to-design” first stage and a very ambitious second stage.

Despite its operational drawbacks with respect to SSTO concepts (three vehicles to operate versus only one), this TSTO configuration offers many advantages in terms of performance and technological feasibility.

- The low velocity of the first stage after the staging maneuver allows a glide back trajectory to the launch site. Therefore the operations appear greatly simplified with respect to the “transatlantic” TSTO (Taranis configuration, ref. 24).



Figure 32. Taranis concept (ref. 24).

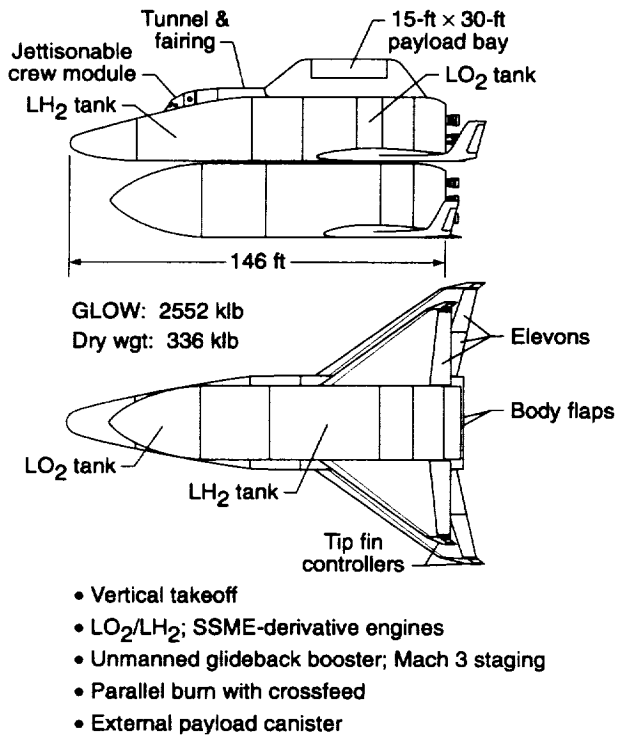

Figure 33. Near-term-technology two-stage AMLS (space-station mission), 40K payload, ref. 21).

- The design effort has to focus on the second stage which appears to be “almost an SSTO” because of the mass fraction, mechanical and thermal load requirements it has to sustain. Nevertheless, the ΔV reduction due to the booster (especially in case of crossfeeding) allows a vehicle design with lower technology level requirements, mainly in propulsion systems and structure mass fraction reduction requirements.

The numerous configurations allowed by this launch system provide many interim options on the way to an affordable SSTO vehicle: (1) expendable first stage, (2) reusable first stage with LOX/hydrocarbon propellants with or without LH2 crossfeeding to the second stage (ref. 25), and (3) reusable first stage with an increased staging speed (the first stage flies back to the launch site using an airbreathing propulsion system). This approach, after the downselection of the “Once Around” and “Antipodal” systems, appears to be one of the most promising interim options to pave the way to a really affordable launch system. Such a concept was studied at NASA Langley as part of the Advanced Manned Launch Systems (AMLS) activities (figure 33, ref.21) and provides an appropriate reference vehicle for this class.

4.2.2.2.1 LOX/LHC Siamese Pop-Down Concept

The Pop-Down procedure (ref. 25) is a method of launching a TSTO vehicle which allows recovery of both stages at the launch site. The booster flies along a strictly vertical flight path so that it always remains above the launch site. This procedure solves the downrange site recovery problem at the expense of a payload mass loss, since the TSTO ascent trajectory is no longer fully optimized.

The first staging analyses of such a Pop-Down launcher have

shown that the propellant masses of both stages were very close to one another. Moreover, since the orbiter needs a high acceleration to minimize the velocity losses, both stages needed the same number of engines. This has led Aerospatiale to select a Siamese concept for further study: both stages contain the same propellant mass and are powered by the same number of engines. Thus, this Siamese TSTO is somewhat characteristic of SSTO vehicles in that there is only one configuration to develop, manufacture, and operate.

4.2.2.3 Challenges

The challenges of the rocket powered TSTO vehicles are very similar to the SSTO systems but generally less severe.

However, TSTO systems pose specific problems: aerodynamic interactions between the stages, staging (especially in case of abort) and crossfeeding.

5. ADVANCED, ENHANCING SYSTEMS CONCEPTS

There are many advanced systems concepts of current interest which may have significant benefits for hypersonic vehicles (ref. 1) that will present system challenges. Advanced concepts are currently under study for configuration, drag reduction, low speed propulsion, LAIR collection/oxygen enrichment, controls and launch assist.

In enhancing the air-breathing SSTO and TSTO designs, the configuration is extremely important. The lifting body that served as a reference may be better if it was designed upside down—inverted lifting-body—as shown in figure 34 (ref. 1). In this arrangement the profile of the vehicle would be a much more favorable airfoil and provide much greater lift at a lower angle-of-attack and thus less drag, especially throughout the subsonic and transonic region. Above the transonic region the vehicle may be more optimum in a conventional engine underslung attitude and thus require rolling 180°.

As air-breathing engine weight increased with design/technology maturation in prior programs, it became apparent that there may be an advantage to switch configurations from a lifting-body to a high-fineness ratio wing-body (figure 34) where engine weight can be traded for wing weight. High-fineness ratio configurations would have lower drag per unit volume and thus require less engine size.

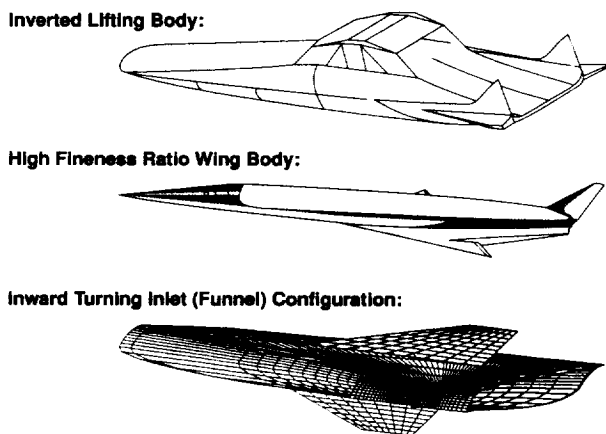

Figure 34. Extended/advanced configuration matrix (ref. 1).

The ultimate hypersonic air-breathing configuration in terms of propulsion flowpath for a point design is the inward turning inlet configuration (ref. 26) as shown in figure 34. Ideally, the funnel inlet configuration offers more air capture and more efficient compression to the inlet throat for less wetted area with an accompanying, more efficient expansion through the radial nozzle than does its two-dimensional or conical counterparts, resulting in potentially higher net thrust and specific impulse. Of course there are concerns such as "on-design/off-design" inlet spillage, volumetric efficiency, etc.

The technology area of magnetogasdynamics (ref. 27) in which a nonequilibrium cold plasma is created ahead/adjacent to the vehicle to reduce shock strength, drag and heat transfer is largely unexplored, although test results point to these favorable phenomena. Steam reforming of hydrocarbon fuel through chemical regeneration and magnetogasdynamic generation of electrical power through deceleration of inlet flows is also profiled in reference 27. As these phenomena become better understood, flight systems must be designed to accommodate them.

Pulse detonation engines (PDE), which use detonation waves propagating through a premixed fuel-air mixture to produce large chamber pressures and thereby thrust, are potentially promising for low speed ($M = 0$ to 5) propulsion (ref. 28). The PDE has the potential for very high specific impulse, and it may be possible to have a single system which can be converted from a low speed airbreather to an efficient pulse rocket for boost to orbit. The PDE consists of a cylinder or series of cylinders which are repeatedly filled with a combustible mixture and detonated. The oxidizer can be air provided by an inlet (airbreather) or gaseous oxygen retrieved from a tank (rocket).

The ejector ramjet allows the ramjet to operate from takeoff to ramjet takeover speed ($M = 3$), and thus a single duct engine that operates over a broad Mach number range is possible (ref. 29). As might be expected, the ejector ramjet requires a large amount of oxidizer which may mean that, to be practical, a vehicle using this system must also extract air and/or oxygen from the atmosphere. The system which extracts air, condenses it, and uses it in an ejector ramjet is called a liquid air cycle engine (LACE). LACE has been studied for many years (ref. 30) as well as other condensing systems such as air collection and enrichment system (ACES) where liquid oxygen is subsequently separated out and stored for later use. The original ACES used an approach where the distillation column process was accelerated through application to a rotating disk which produced centrifugal force analogous to an increase in gravity. Many other methods for extracting oxygen from air are currently being studied (ref. 1).

In the controls area, neural networks (ref. 31) appear to offer a significant advancement for both the airframe and engines controls and the coupling between the two. Accurate Automation Corporation is currently in the process of demonstrating a neural network for the rudder control of a hypersonic waverider configuration at subsonic speeds in their LoFLYTE™ flight test vehicle (figure 35).

For takeoff assist, Mag Lifter technology (magnetic field used to accelerate vehicle, ref. 32) is being examined for rail launch

in NASA's Advanced Space Transportation Program. Takeoff assist is more beneficial to vehicles that have higher LOX fractions in which a higher percentage of propellant would have been burned had not the assist delta velocity been provided.

6. COMMON SYSTEM CHALLENGES

All the hypersonic vehicles described heretofore pose formidable system problems: (1) vehicles are high speed and long range, (2) vehicles are subjected to severe environment, but must be lightweight, (3) vehicles' propulsion systems and airframes have to be intricately integrated, (4) vehicles' major characteristics have considerable uncertainties since the realm of hypersonics remains widely unexplored, and they are sensitivity intensive, and (5) vehicles must accommodate a wide flight envelope.

Most of these challenges will be resolved with tangible means (efficient propulsion, lightweight structures...). These are identified herein and addressed in other AGARD papers. However, more impalpable means can contribute.

6.1 Guidance, Navigation and Control (GN&C)

GN&C is considered an enabling technology for hypersonic vehicles because beyond the aforementioned problems: (1) they have to be autonomous for they are long range vehicles and/or military vehicles and/or subjected to the blackout phenomena, (2) they may have very short response times, flexible structures, propellant sloshing, and (3) they have to use sophisticated sensors (high speed Air Data Systems, seekers behind high temperature windows, etc.).

Hypersonic vehicles need high performance explicit/adaptive guidance and control. Explicit guidance allows on-board, real-time trajectory computations. For instance, a lifting re-entry missile whose target would be out of range may re-optimize its trajectory, make an atmospheric skip and hit the bull's eye. Adaptive control allows accounting for vehicle uncertainties in real time and to adapt, in real time, the guidance and control algorithms. Using more recent control methods, like H_{∞} or neural networks, explicit and adaptive GN&C will ease the hypersonic vehicles design and operation.

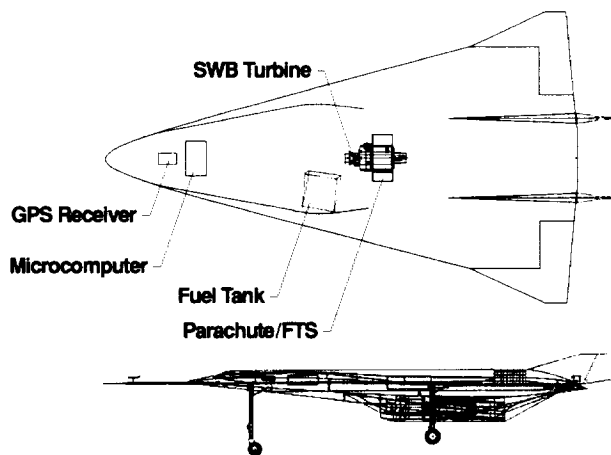

Figure 35. LoFLYTE Subsonic Neural Net Demonstrator (ref. 1).

6.2 Telecommunications

Telecommunications with hypersonic vehicles pose specific problems: (1) antennas are to be protected against high heat loads, (2) the radio communication blackout phenomena, and (3) the long range of hypersonic flight may dictate the development of a network of ground stations and/or satellites.

During its hypersonic flight, the vehicle is subjected to high heat loads which may cause air ionization (plasma). The radio communication blackout phenomena is caused by the plasma sheath which surrounds the vehicle. Possible solutions to this phenomena are: (1) use frequencies higher than the plasma cut-off frequency, (2) select a proper antenna location, and (3) use other communication means (laser...).

6.3 Reliability, Availability, Maintainability and Safety

The vehicle's reliability by itself is often not sufficient to justify the development of a hypersonic vehicle. For example, consider a reusable launcher whose reliability is only 0.99. Statistically, this translates to the loss of one vehicle every 100 flights. This is why reliability enhancement for reusable launch vehicles is so important and why built-in abort strategies have to be included to increase the probability of recovering the vehicle and its payload (crew survivability should be greater than 0.999, ref. 13).

A low availability could negate the speed advantage of most hypersonic vehicles. Responsiveness is a major operational issue, especially for military vehicles.

Maintainability is one of the key issues for hypersonic vehicles in terms of what is required and what it will cost. For instance, should the maintenance cost per mission represent 1% of the vehicle cost, the total maintenance cost over 100 missions would amount to the cost of one vehicle (2%, two vehicles, etc). Technology maturation and demonstrators are therefore mandatory to reduce the maintenance uncertainties. Proper design and operation methodology (e.g. aircraft like) and health monitoring systems are also mandatory.

Also hypersonic vehicles pose specific problems of safety, both from the range safety viewpoint and from the crew safety viewpoint. For major malfunction at hypersonic speed crew rescue is a challenge. Either vehicle integrity must be maintained before ejection seats can be used or the crew cabin has to be ejected.

6.4 Operations

Reusable vehicles must be designed for operations and maintenance (ref. 9) to minimize the life cycle costs and to maximize responsiveness. The enhancement of systems/subsystems reliability in conjunction with an extension of their cycle life is a must in reducing operational cost. Present-day operations consist of expensive tasks to prepare and operate vehicles. This is no longer affordable; vehicles and operations have to be designed concurrently. Vehicles can no longer be designed from just a performance/weight-minimization perspective.

Operations must be automated (no "standing army") to reduce costs and streamlined to increase responsiveness. The vehicle designed for operations provides more robust-

ness to the system; autonomous and fault tolerant architectures are to be favored.

Among the ideas to increase vehicle operability are: (1) to some extent use aircraft lessons learned, (2) develop and use an inflight health monitoring system, (3) use robust, fast-response, fault-tolerant software and avionics, (4) avoid hypergolic propellant, and (5) reduce the reliance on hydraulic systems; use electromechanical actuators where possible.

7. CONCLUDING REMARKS

Systems/subsystems architecture for fully reusable hypersonic airplanes and space access vehicles were examined. Screening categories were takeoff, landing, propulsion systems, fuels/propellants, mission and staging. System/subsystem challenges were identified.

For hypersonic airplanes, emphasis was focused on Mach 5 and 10 cruise with hydrocarbon and hydrogen fuel, respectively. Developing the powerplants (turboramjets or LACE ejector-ramjets and dual-mode ramjets/scramjets) and performing an efficient airframe propulsion integration as well as thermal management are the main issues. For the endothermic-hydrocarbon fueled systems (Mach < 8), hot, integral titanium tank structure appears viable. For the hydrogen-fueled systems (Mach > 8), cold, integral graphite/epoxy tank structure with graphite composite interfaces and external insulation/TPS is the architecture of choice.

For access to space vehicles, emphasis was focused on single- and two-stage, airbreathing and rocket propelled systems with horizontal takeoff for airbreathers and vertical takeoff for rockets. For the airbreather, propulsion and propulsion integration along with thermal management are still the biggest challenges; this is essentially the same as with cruise vehicles except for the additional rocket integration for orbital access in SSTO vehicles and pullup (if required) for staging in the TSTO boosters. The airbreathing propulsion systems have the potential for long cycle life which could have a positive effect on reducing operational cost (lower frequency of changing engines and pumps). For structures, the emphasis is on cold, integral graphite/epoxy hydrogen tanks and graphite composite interfaces. The airbreathing vehicles, being lifting configurations, are designed for normal loads and thus are conducive to abort situations. For SSTO vehicles, one of the biggest challenges may be to overcome negative paradigms with respect to the use of slush hydrogen.

For rocket powered systems, the main challenges are to mature the enabling technologies to ensure operation feasibility. This feasibility depends on the development of necessary technologies for required dry mass fraction with built-in margins that will provide reliable systems with favorable cycle life. Some of these technologies such as cryogenic, integral tankage, etc. are common to airbreathers as well. These technologies are being pursued in the U.S. X-33, X-34 and Advanced Space Technology Program (ASTP) programs.

Even though less demanding than SSTO vehicles, TSTO systems pose specific problems: aerodynamic interactions, cross-fueling, and staging, among others.

Vacuum thrust, lb.	463,900
Sea-level thrust, lb.	402,600
Chamber pressure, psia	3,000
Area ratio	50
Vacuum specific impulse, sec.	447.3
Sea-level specific impulse, sec.	387.9
Oxidizer/fuel	6.0
Weight, lb.	6,780

Table 1. SSME-derivative engine performance characteristics (ref. 16).

8. REFERENCES

- Hunt, J.L.; Lockwood, M.K.; Petley, D.H.; and Pegg, R.J.: Hypersonic Airbreathing Vehicle Visions and Enhancing Technologies. Space Technology and Applications International Forum. AIP Conference Proceedings 387, Albuquerque, New Mexico, 1997.
- Pegg, R. J.; Hunt, J. L.; Petley, D. H.; Burkardt, L.; Stevens, D. R.; Moses, P. L.; Pinckney, S. Z.; Kabis, H. Z.; Spoth, K. A.; Dziedzic, W. M.; Kreis, R. I.; and Barnhart, P. J.: Design of a Hypersonic Waverider-Derived Airplane. AIAA 93-0401, Reno, Nevada, January 11-14, 1993.
- Hunt, J. L.; and Eiswirth, E. A.: NASA's Dual-Fuel Airbreathing Hypersonic Vehicle Study. AIAA 96-4591, Norfolk, Virginia, November 18-22, 1996.
- Bogar, T.J.; Eiswirth, E.A.; Couch, L.M.; Hunt, J.L.; and McClinton, C.R.: Conceptual Design of a Mach 10, Global Reach Reconnaissance Aircraft. AIAA 96-2894, Lake Buena Vista, Florida, July 1-3, 1996.
- Bogar, T.J.; Alberico, J.F.; Johnson, D.B.; Espinosa, A.M.; and Lockwood, M.K.: Dual-Fuel Lifting Body Configuration Development. AIAA 96-4592, Norfolk, Virginia, November 18-22, 1996.
- Lau, K. Y.; Scuderi, L. F.; Petley, D. H.; and Yarrington, P. W.: Dual Fuel Vehicle Thermal Management. AIAA, Norfolk, Virginia, November 18-22, 1996.
- Weirich, T. L.; Fogarty, W.; Dry, K.; Iqbal, A.; and Moses, P.: Dual-Fuel Vehicle Airframe and Engine Structural Integration. AIAA 96-4594, Norfolk, Virginia, November 18-22, 1996.
- Mercier, R.A.; and Ronald, T.M.F.: U.S. Air Force Hypersonic Technology Program (HyTech). Preliminary Sections Paper, AIAA 7th International Space Planes and Hypersonics Systems and Technologies Conference, Norfolk, VA, November 1996.
- Space Propulsion Synergy Team: A Guide for the Design of Highly Reusable Space Transportation. NASA Headquarters, November 1996.
- Fazi, D.; Wagner, A.; and Johnson, C.: STS 2000: An Outline. IAF 90-192, 41st Congress of the International Astronautical Federation, Dresden, Germany, October 6-22, 1990.
- Wagner, A.; and Bombled, J. P.: Oriflamme: A Reference Airbreathing Launcher to Highlight Areas that are Technological Drivers for Hypersonic Vehicles. IAF 91-207, 42nd Congress of the International Astronautical Federation, Montreal, Canada, October 5-11, 1991.
- Falempin, F.; Lacaze, H.; Wagner, A.; and Viala, P.: Reference and Generic Vehicle for the French Hypersonic Technology Program. AIAA 95-6008, Chattanooga, Tennessee, April 3-7, 1995.
- Access to Space Study: Summary Report; Office of Space Systems Development, NASA Headquarters, January 1994.
- Bekey, I.; Powell, R.; and Austin, R.: NASA Studies Access to Space. Aerospace America, May 1994.
- Hunt, J. L.: Airbreathing/Rocket Single-Stage-to-Orbit Design Matrix. AIAA 95-6011, Chattanooga, Tennessee, April 3-7, 1995.
- Bekey, I.: Why SSTO Rocket Launch Vehicles are Now Feasible and Practical. IAF 94-V.1.524, 45th Congress of the International Astronautical Federation, Jerusalem, Israel, October 9-14, 1994.
- Stanley, D. O.; and Piland, W. M.: Technology Requirements for Affordable Single-Stage Rocket Launch Vehicles. Space Technology, Volume 14, No.5, pp. 319-330, 1994.
- Stanley, D. O.; Engleund, W. C.; Lepsch, R. A.; McMillin, M.; Wurster, K. E.; Powell, R. W.; Guinta, T.; and Unal, R.: Rocket-Powered Single-Stage Vehicle Configuration Selection and Design. Journal of Spacecraft and Rockets, Volume 31, No. 5, pp. 792-798, 1994.
- Wagner, A.: A Generic Fast Airbreathing First Stage TSTO Vehicle Radiance. AIAA 95-5084, Orlando, Florida, December 1-4, 1992.
- Gregory, T.; Bowles, J.; and Ardema, M.: Two Stage to Orbit Airbreathing and Rocket System for Low Risk, Affordable Access to Space. SAE 941168, SAE 1994 Aerospace Atlantic Conference and Exposition, Dayton, Ohio, April 19, 1994.
- Freeman, D. C.; Talay, T. A.; Stanley, D. O.; Lepsch, R. A.; and Wilhite, A. W.: Design Options for Advanced Manned Launch Systems. Journal of Spacecraft and Rockets, Volume 32, Number 2, pp. 241-249.
- Wagner, A.; Deneu, F.; Grazziani, S.; and Lancelot, J.: TSTO: The Next Step. 48th IAF Congress, Torno, Italy, 1997.
- Wagner, A.; and Deneu, F.: Future Launchers at Aerospatiale: A Status Report. 1997 AIAA Defense and Space Programs Conference and Exhibit.

24. Abriat, E.; and Bombled, J. P.: Advanced TSTO VTOHL Reusable Rocket—A Study Report. IAF 89-866.
25. Terrenoire, P. H.; Masse, B.: An Overview of the Reusable Rocket Launchers Based on Near Term Technologies. IAF 94-539.
26. Kothari, A. P.; Tarpley, C. et al.: Hypersonic Vehicle Design Using Inward Turning Flowfields. AIAA 96-2552, 1996.
27. Gurijanov, E. P.; and Harsha, P. T.: AJAX: New Directions in Hypersonic Technology. AIAA 96-4609, Norfolk, Virginia, November 18-22, 1996.
28. Bussing, R. R. A.; and Pappus, G.: An Introduction to Pulse Detonation Engines. AIAA 94-0263, 1994.
29. Bulman, M.; and Siebenhaur, A.: A Strutjet Engine: Exploding the Myths Surrounding High Speed Airbreathing Propulsion. AIAA 95-2475, 1995.
30. Balepin, V.; Cozzog, P.; Marta, M.; and Vanderkerckhove: Assessment of SSTO Performance with In-Flight LOX Collection. AIAA 95-6047, 1995.
31. Sacks, R.; Cox, C.J.; and Pap, R.M.: LoFLYTE™: A Neurocontrols Testbed. AIAA 97-0085, 35th Aerospace Sciences Meeting & Exhibit, Reno, Nevada, January 1997.
32. Mankins, J. C.: The MagLifter: An Advanced Concept Using Electromagnetic Propulsion in Reducing the Cost of Space Launch. AIAA 94-2726, 30th Joint Propulsion Conference and Exhibit, Indianapolis, Indiana, June 1994.