

Summary of Activities

1996

NASA's Microgravity Technology Report

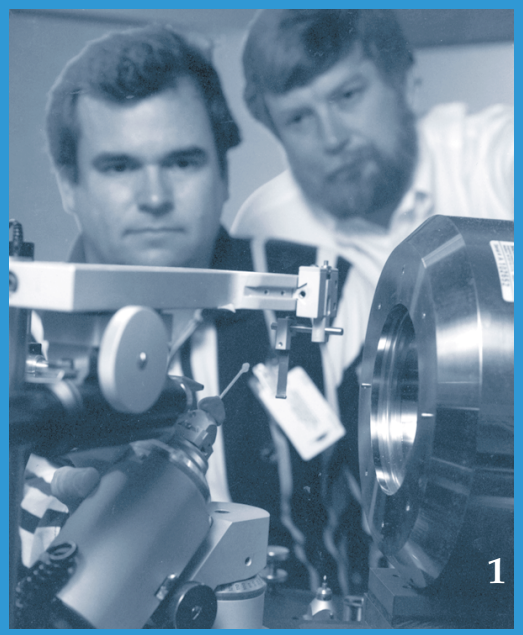

Bioreactor for Engineering Tissue in Space

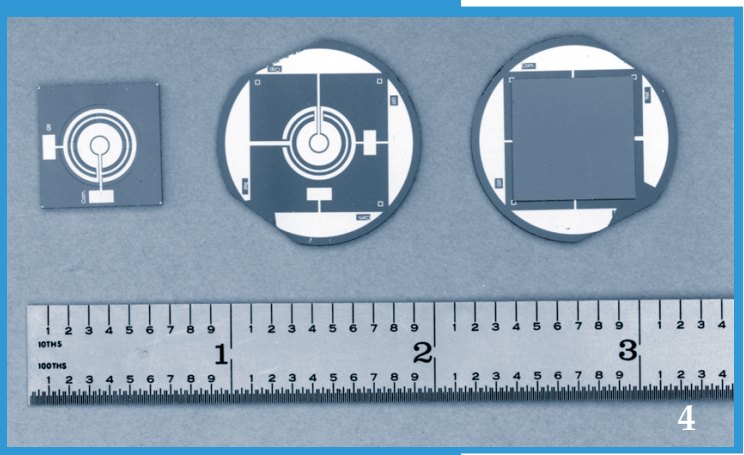
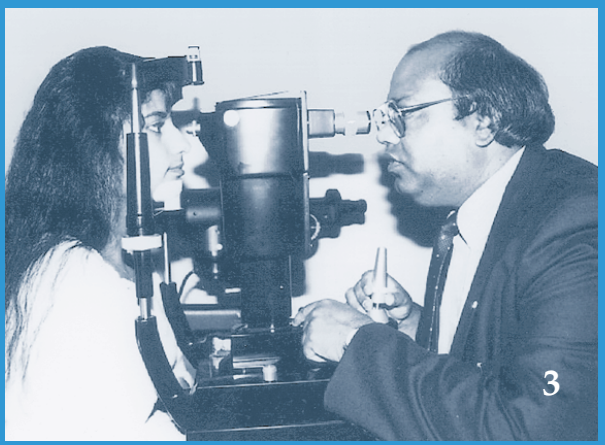
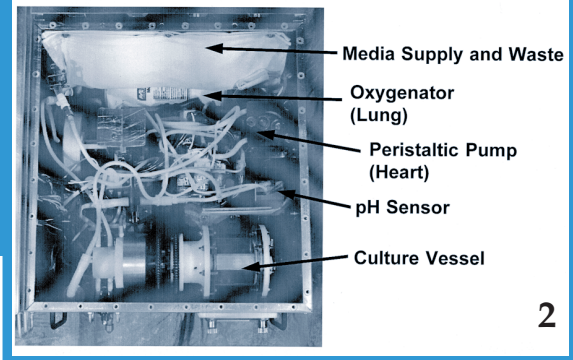

NASA's
Microgravity
Technology Report

1996

Summary of Activities

NASA TM-108538



National Aeronautics and
Space Administration

George C. Marshall Space Flight Center
Marshall Space Flight Center, Alabama 35812

Acknowledgments

This report was prepared by Isabella Kierk, the Microgravity Technology Development and Transfer Program Manager, who would like to thank NASA Field Center microgravity technologists for their support and coordination of data collection. Special thanks go to the Jet Propulsion Laboratory (JPL): Mark Lysek; the Johnson Space Center (JSC): Dennis Morrison; the Lewis Research Center (LeRC): Tom Glasgow; and the Marshall Space Flight Center (MSFC): Ann Trausch, for their valuable contributions to this document.

Description of Cover Photographs

1. High Brilliance X-Ray Instrument—This instrument provides a means to determine the atomic structure of crystalline matter, with medical applications.
2. Bioreactor for Engineering Tissue in Space—Space bioreactors overcome gravity-induced limitations in cell cultures and tissue engineering, producing samples that greatly enhance in-depth investigation.
3. Dynamic Light Scattering Probe—Light scattering technology is used to detect cataracts in the early developmental stages.
4. Low Temperature Pressure Sensor Technology—Very small and precise micromachined silicon capacitive pressure sensor-transistor.

1.0	INTRODUCTION	1
1.1	Purpose	1
1.2	Scope	1
1.3	Background	1
2.0	MICROGRAVITY SCIENCE RESEARCH PROGRAM TECHNOLOGY ASSESSMENT AND SELECTION POLICY	2
2.1	Identification of Technology Requirements and Priorities	2
2.2	Evaluation of Proposed Technology Developments	2
2.3	Evaluation Criteria	3
2.4	Metrics	3
2.5	Technology Planning and Development—Coordination With Other NASA Offices, Federal Agencies, and Universities	3
2.6	International Cooperation	4
2.7	Advanced Technology Development Program	5
2.8	Technology Transfer Programs	6
3.0	MICROGRAVITY SCIENCE RESEARCH PROGRAMS AND RELATED TECHNOLOGY DEVELOPMENTS AND REQUIREMENTS	11
3.1	Biotechnology	11
3.2	Combustion Science	12
3.3	Fluid Physics	13
3.4	Fundamental Physics	14
3.5	Materials Science	15
3.6	Multidiscipline Technologies	16
	APPENDIX A—FY 1996 ADVANCED TECHNOLOGY DEVELOPMENT PROGRAM AND PROJECT DESCRIPTIONS	17
	Program Description	17
	Project Descriptions	17
	APPENDIX B—TECHNOLOGY DEVELOPMENTS	47
	B.1 Biotechnology	47
	B.2 Combustion Science	52
	B.3 Fluid Physics	53
	B.4 Fundamental Physics	55
	B.5 Materials Science	61
	B.6 Multidiscipline Technology	65

1.	Cryogenic dilatometer for measurement of variations in magnetostrictive crystal length to 0.25-micron accuracy	18
2.	Optical intensity (absorption) profile along the line in figure 3 crossing the solute layer and interface. Solute gradient is clearly seen on the left part of the graph. Increasing indium content represents increased absorption. The diffuse interface region is in the marked area. Note the solute layer is not uniform along the length of the interface	20
3.	Solid-liquid interface of Al-18 In, growing at 12.4 microns/sec in a 45 °C/cm temperature gradient and showing solute rejection to the liquid after the step increase of translation rate	20
4.	Cutaway schematic of isothermal furnace liner	23
5.	On-line system test-bed	26
6.	(a) On-line separation system, and (b) downstream separation system	26
7.	Compact solid-state coaxial backscatter laser Doppler velocimetry	28
8.	Superconducting pressure transducer	29
9.	Capacitive pressure transducer	29
10.	Flight trajectory of the DC-9 reduced-gravity aircraft	31
11.	Top and side views of the Passive Free-Vortex Separator	33
12.	The Interferometric Laser Vibrometer with autotracking optics. A cone of light is projected onto the fluid surface. All light paths from the surface to the detector have the same transit time. Two examples of return paths are shown. These lines are actually the center lines of returning cones of light (to avoid clutter, only one returning cone of light is shown)	35
13.	Optical path length variation across a silicone oil drop on a coated single-crystal silicon wafer	38
14.	Variation of the reflectivity (fringe visibility) across a silicone oil drop on a coated single-crystal silicon wafer	38
15.	In the fluidic system, each valve port is used to prepare one-half of the crystal growth solution. The final solution is freshly mixed just prior to injection into the growth cell. More solution components, or a larger number of proteins, can be accommodated by the addition of more eight-port solution-selector valves	39

16.	Circuit for excitation and readout of penetration depth thermometer sensors. I_{excit} and $I_{ps1,2}$ are the excitation and persistent switch heater currents	41
17.	Simultaneous LIF–LII image of burning fuel droplet of decone using (a) 266 nm excitation, and (b) separate LII image using 1,064 nm excitation	43
18.	VPS chamber	45
19.	VPS chamber interior	45

1.	ATD Program metrics	6
2.	FY 1996 Technology Transfer Program metrics	10
3.	FY 1995 Technology Transfer Program metrics	10
4.	Microgravity biotechnology program technologies	11
5.	Microgravity combustion science program technologies	12
6.	Microgravity fluid physics program technologies	13
7.	Fundamental physics program technologies	15
8.	Microgravity materials science program technologies	16
9.	Multiple science disciplines technology	16

Abbreviations & Acronyms

AADSF	Advanced Automated Directional Solidification Furnace
AGHF	Advanced Gradient Heating Furnace
AlN	aluminum nitride
APCF	Advanced Protein Crystallization Facility
ATD	Advanced Technology Development
BCM	BTS computer module
BDPU	Bubble, Drop, and Particle Unit
BEM	BTS experiment module
BRS	bioproduct recovery system
CAB	copper ammonium bromide
CATCH	Canadian-American Crystallization Hardware
CCD	charge-coupled device
CdZnTe	cadmium zinc telluride
CGF	Crystal Growth Furnace
CHeX	Confined Helium Experiment
CNES	French National Center for Space Studies
CNRS	Combustion and Reacting Systems
CO ₂	carbon dioxide
CPU	central processing unit
CRADA	Cooperative Research and Development Agreement
CSA	Canadian Space Agency
CVD	chemical vapor deposition
DARA	German Space Agency
DCAM	Diffusion-Controlled Crystallization Apparatus for Microgravity
DCPCG	dynamic control of protein crystal growth
DOE	diffractive optical elements
DSP	digital signal processing
DYNAMX	Dynamics in Microgravity Experiment
EMC	electromagnetic containment
EMI	electromagnetic interference
ESA	European Space Agency
FVS	Passive Free-Vortex Separator
GaAs	gallium arsenide
GCEL	Ground Control Experiments Laboratory
GdCl ₃	gadolinium trichloride
GN ₂	gaseous nitrogen
GSM	gas supply module
He	helium
HEDS	Human Exploration and Development of Space
HgZnSe	mercury zinc selenide
HgZnTe	mercury zinc telluride
HHDTc	Hand-Held Diffusion Test Cell
HQ	Headquarters
HRT	High-Resolution Thermometry
IML	International Microgravity Laboratory
IR	infrared
ISS	<i>International Space Station</i>
JPL	Jet Propulsion Laboratory
JSC	Johnson Space Center
LED	light emitting diode
LPE	Lambda Point Experiment
LeRC	Lewis Research Center
LFI	Laser feedback interferometry
LIF	Laser-Induced Fluorescence

LII	Laser Induced Incandescence
low-g	low-gravity
LTMP	Low-Temperature Microgravity Physics
MEPHISTO	Materials for the Study of Interesting Phenomena On Orbit
MGHPF	Moving Gradient Heat Pipe Furnace
MGM	mechanics of granular materials
MSAD	Microgravity Science and Applications Division
MSFC	Marshall Space Flight Center
NASDA	Japanese Space Agency
Ne	neon
NIH	National Institutes of Health
NIST	National Institute of Standards and Technology
NRA	NASA Research Announcement
NSOM	near-field scanning optical microscope
O ₂	oxygen
OLMSA	Office of Life and Microgravity Sciences and Applications
OPCGA	observable protein crystal growth apparatus
OSA	Optical Society of America
OSAT	Office of Space Access and Technology
PAH	polycyclic aromatic hydrocarbon
PC	personal computer
PCAM	Protein Crystallization Apparatus for Microgravity
PCG	Protein Crystal Growth
PCGAC	Protein Crystal Growth Analysis Chamber
PCS	Passive Culture Systems
PDT	penetration depth thermometer
PI	principal investigator
PIV	particle image velocimetry
PSCS	Perfused Stationary Culture Systems
R&D	research and development
RF	radio frequency
SAMS	Space Acceleration Measurement System
SBIR	Small Business Innovation Research
SET	single electron transistor
SIV	stereo imaging velocimetry
SQUID	superconducting quantum interference detector
SS/L	Space Systems/Loral
SSFF	Space Station Furnace Facility
STEP	Satellite Test of the Equivalence Principle
STS	Space Transportation System
TA	Technology Affiliates
TCA	Technology Cooperation Agreements
TSA	Two-Stage SQUID Amplifier
TSSA	Two-Stage Series Array SQUID Amplifier
USML	United States Microgravity Laboratory
USMP	United States Microgravity Payload
UVA	University of Amsterdam
VPS	vacuum plasma spray
WWW	World Wide Web
XTM	X-Ray Transmission Microscope
ZnSeS	zinc selenium sulfide
ZnSeTe	zinc selenium telluride
ZnTe	zinc telluride

1.1 *Purpose*

This document updates the Microgravity Science and Applications Division (MSAD) technology development policy, and presents and assesses current technology-related activities and requirements identified within MSAD research and technology programs. It serves as a prime source of information for the National Research Council, the Administration's Office of Science and Technology Policy, the Office of Management and Budget, and the Congress to promote technology as a means for scientific and economic growth.

1.2 *Scope*

This report covers technology development and technology transfer activities within the Microgravity Science Research Programs during FY 1996. It also describes the recent major tasks under the Advanced Technology Development (ATD) Program and identifies current technology requirements. This document is consistent with NASA's *Enterprise for the Human Exploration and Development of Space (HEDS) Strategic Plan*. This annual update reflects changes in the Microgravity Science Research Program's new technology activities and requirements.

1.3 *Background*

Microgravity, the low-gravity environment found in orbiting spacecraft, has unique characteristics that allow investigations of phenomena and processes that are difficult or impossible to study on Earth. NASA's MSAD sponsors research on important biological, chemical, and physical processes in a microgravity environment in five major areas:

- Biotechnology
- Combustion science
- Fluid physics
- Fundamental physics
- Materials science.

Technology plays a critical role in all microgravity research areas.

Without *basic* science to enlarge the body of knowledge, science cannot continue to produce practical benefits. Without new technologies, neither basic nor applied science can progress. Basic and applied research built the knowledge base underlying most of the practical benefits that society has realized from technology. Clearly, new technology requirements originate from science needs, since technology continues to open new avenues for enabling more innovative and enhanced types of research.

Microgravity Science Research Program Technology Assessment and Selection Policy

2.1

Identification of Technology Requirements and Priorities

In FY 1996, the second annual technology survey was conducted at the NASA Field Centers, providing data on ongoing and proposed technology activities, and identifying new technology requirements during FY 1995. The results of this survey have been documented in *NASA's Microgravity Technology Report—Summary of Activities in FY 1995*.

More than 20 technology poster sessions were presented in the Discipline Science Workshops and Technology Conferences during FY 1996, helping microgravity scientists and technologists to communicate the results of their work and identify new technology needs. There are plans to stage an annual microgravity, discipline science oriented, technology workshop to further improve these communications and to consider other effective mechanisms to identify and prioritize new technology requirements. These prioritized technology requirements will help both the researchers working under the ATD Program, and the discipline science programs to focus their efforts on the Human Exploration in Space Enterprise and Microgravity Science Research Program priorities, and the program evaluators to select the best technology proposals for funding.

2.2

Evaluation of Proposed Technology Developments

In FY 1996, the Microgravity Science Research Program participated in the evaluation of proposed technologies under several technology development programs.

Through the Microgravity Science Research Program-funded ATD Program, from a total of 24 two-page concept papers, 9 were selected for full proposals, and 6 of these were selected for technology development in FY 1997. The technology development selections were:

- (1) Applications of Superconducting Cavities to Microgravity Research
- (2) Development of an Electrostriction Cold Valve-Phase Separator
- (3) Advanced Diagnostics for Combustion
- (4) Multiple Scattering Concerns in Dynamic Light Scattering
- (5) New Optical Technique for Protein Crystal Growth Diagnostics
- (6) Vibration Isolation and Control System for Small Microgravity Payloads.

The Microgravity Technology Development and Transfer Program Manager also participated in the evaluation of the Small Business Innovation Research (SBIR) Program technology proposals and the Advanced Concepts Research Projects managed by the NASA Office of Space Access and Technology (OSAT).

2.3

Evaluation Criteria

Criteria used to evaluate technology developments within the Microgravity Science Research Program in FY 1996 included:

- Criticality to microgravity science and experiment programs
- Potential for enabling new microgravity science and experiments
- Technology payoff—return on investment
- Technology feasibility
- Soundness of the plan—timeliness, schedule, resources, etc.
- Expertise of the group developing the technology
- Potential for technology transfer.

2.4

Metrics

In FY 1996, metrics used in Microgravity Science research and technology programs included:

- Number of technical/scientific publications
- Number of citations in technical/scientific literature
- Return on investment (funds gained from the program/technology versus funds invested)
- Number of patents (applied for and awarded)
- Number of corporate agreements (technology transfer)
- Number of flight programs using the evaluated technology
- Number of principal investigators (PI) and co-investigators working under the program
- Number of graduate students funded under the program
- Number of graduate degrees granted under the program
- Size of the portfolio (total dollars spent on research/technology development and transfer partnerships by NASA and its partners).

Metrics for the ATD Program and Technology Transfer Programs are listed in sections 2.7 and 2.8.

2.5

Technology Planning and Development

Coordination With Other NASA Offices, Federal Agencies, and Universities

During FY 1996, NASA continued to emphasize the collaborative NASA–National Institutes of Health (NIH) biotechnology programs, with the focus on:

- Establishing joint NASA–NIH centers that will accelerate the transfer of NASA technology and allow its application to biomedical research
- Developing advanced tissue culturing technology, and applying this breakthrough technology to biomedical research and developmental biology
- Developing advanced protein crystallization technologies to advance structural biology and drug design to fight a number of diseases
- Developing technology for the early detection of cataracts.

The NASA–NIH collaboration offers an opportunity to address the technical challenges of three-dimensional tissue growth, crystallization of high-quality protein crystals, and the early detection of cataracts by supporting multidisciplinary research teams. These research teams allow some of America's best scientists and bioengineers to address these complex problems and accelerate development of the technologies.

Work at NASA's LeRC demonstrated that laser light scattering technology (a past ATD project) could be used to measure the size distribution of a protein in the eye that is related to the early developmental stages of cataracts; discussions with managers from the NIH National Eye Institute led to the decision to proceed with development of a prototype diagnostic tool. (Section 2.8 provides further details.)

In FY 1996, NASA's MSAD worked with the National Eye Institute to develop an interagency agreement for cooperative efforts in this area. Subsequent to successful demonstration, the National Eye Institute was interested in obtaining the technology for use in a large-scale clinical trial. Microgravity researchers also collaborated with researchers at the National Eye Institute using protein crystal growth (PCG) technology to determine the structures of important proteins related to the signal pathway for sight, through a joint program between NASA, NIH, and Eli Lilly and Company.

In fall 1996, NASA and the NIH also signed an agreement to facilitate the development of a new x-ray technology with the potential to improve scientific research and enhance the quality of life through better medical imaging instruments. The collaborative research agreement takes new x-ray technology recently developed by MSFC, along with X-Ray Optical System, Inc., Albany, NY, and the Center of X-Ray Optics of the State University of New York at Albany, and enhances its imaging capabilities for a variety of commercial uses. Expected applications in scientific research and medicine include improved manufacturing control for semiconductor circuits and better medical imaging, such as in mammography and improved forensics. Once developed, the x-ray device will enhance a researcher's ability to determine difficult proteins at a faster pace, which is critical to new drug design.

The NASA-developed x-ray technology is capable of generating beams that are more than 100 times the intensity of conventional x rays. At the heart of the NASA technology is a new type of optics for x rays called "capillary optics." The x rays can be controlled by reflecting them through tens of thousands of tiny curved channels, or capillaries, similar to the way light is directed through fiber optics. The high-intensity beams will permit scientific and medical research to be performed in less time, with higher accuracy, and could permit the use of smaller, lower-cost, and safer x-ray sources. NASA's contribution to the agreement is sponsored by the Microgravity Research Program Office at MSFC, for the Office of Life and Microgravity Sciences and Applications (OLMSA) at NASA Headquarters (HQ). This new agreement is based on pioneering work in the field previously sponsored by Microgravity Research. The technology will eventually be applied to research on the space shuttle and the *International Space Station (ISS)*. The agreement between NASA and the NIH is effective until September 30, 1999.

The Microgravity ATD Program continued to involve collaborations with the National Institute of Standards and Technology (NIST) on a room-temperature Superconducting Quantum Interference Detector (SQUID) project with Sandia Laboratory, in the laser induced incandescence technology area, and with the Tennessee Space Institute and the University of Chicago, in stereo imaging velocimetry technologies. Other university participants in the ATD Program included: the University of Delaware, in a free-float trajectory management ATD project; Stanford University, in a high-resolution pressure transducer and controller project; the University of Alabama, in multicolor holography and real-time x-ray microscopy; and Case Western Reserve University, in surface light scattering.

In September 1996, the NASA OSAT was dissolved; all divisions within OSAT were reassigned to other NASA offices. As a result of this change, the Space Processing and Commercialization Division joined OLMSA. This merger should result in much stronger cooperation between the Space Processing and Commercialization and MSAD in supporting technology developments and commercialization activities.

2.6

International Cooperation

In FY 1996, MSAD held or participated in several international meetings and conferences, which are listed in *NASA's Microgravity Science Research Program*. One of the important events during 1996 took place in June, when the newly formed International Strategic Planning Group for Microgravity Science and Applications Research met for the first time.

The International Strategic Planning Group for Microgravity Science and Applications Research consists of representatives from all the space agencies involved in the *ISS*: NASA, the European Space Agency (ESA), the French National Center for Space Studies (CNES), the Canadian Space Agency (CSA), the German Space Agency (DARA), and the Japanese Space Agency (NASDA). The group met in Huntsville, AL, June 7–8, to begin steps for producing a global strategic plan for microgravity research. These steps included a review of interagency agreements; a comparison of experiment facility development to eliminate duplication of effort; a session on the proposal selection process for the *ISS*; a consideration of research opportunities during all three phases of *ISS* buildup, from prior to assembly to assembly complete; and a discussion of the development of a microgravity database and communications link. It is anticipated that technology issues will more frequently become topics for discussion in the future meetings of this group.

The Biotechnology Cell Science and Tissue Culture Program participated in two international meetings in FY 1996. The first was the 1996 World Congress on In Vitro Biology held in San Francisco, CA, June 22–26. The second was the Cell Transplant Society Third International Congress, entitled "Cellular Transplantation: The Next Frontier," held in Miami, FL, September 29–October 2.

Other international events, all related to work performed under the ATD Program, included meetings held in the Netherlands, Italy, and Poland. These are briefly described below.

The Netherlands

An ATD project researcher from NASA's LeRC spent 8 wk in residence at the Van der Waals Laboratory at the University of Amsterdam (UVA), beginning June 20. He worked in close cooperation with a research faculty member at UVA. The focus of their work was to recreate and apply LeRC's anti-slosh optical train and miniaturized surface light scattering instrument to a critical fluids experiment. This experiment was one of many critical fluids experiments performed by the faculty at Van der Waals Laboratory, who are world leaders in studying critical phenomena.

The collaborative work between NASA and the Van der Waals Laboratory produced several synergistic developments. Primary among these were a new technique to image a spectroscopic grating on a surface fluid and a new cell design that supersedes the anti-slosh optical train for experiments in which the fluid can be contained in a transparent, cylindrical cell. The researchers filed invention disclosure documents on both these ideas. Researchers at the Van der Waals Laboratory are pursuing the possibilities of including the new cell design, as well as cross-correlation bulk laser light scattering, in future flight experiments.

Italy

Laser induced incandescence (LII) technologies developed under the ATD Program were presented at the International Combustion Symposium in Naples, Italy. The international science community had shown interest in using these technologies for soot measurements. The laboratory of Combustion and Reacting Systems (CNRS), Orleans, France, inquired about using the LII technologies on the Caravelle microgravity aircraft.

MSAD cosponsored an Optical Society of America (OSA) Photon Correlation Spectroscopy topical meeting held in Capri, Italy, August 21–24. This meeting gathered together over 80 world experts in laser light and surface light scattering. Fourteen of the 45 peer-reviewed papers presented at the meeting were based on MSAD-supported work.

Poland

The OSA meeting was immediately followed by a NATO Advanced Workshop in Laser Light Scattering held in Krakow, Poland, August 26–30. U.S. scientists met with colleagues from both Eastern and Western Europe to discuss light scattering during these two meetings. The Microgravity Technology Development and Transfer Program Manager

participated in both meetings and discussed NASA's microgravity technology programs, focusing on international cooperation and technology transfer. These topics created much interest throughout the international science community and need to be pursued in the near future.

Laser light scattering equipment, developed under the ATD Program, has been flown and is being used by both NASA and ESA in several upcoming flight experiments that require reduced gravity, such as critical phenomena, colloidal studies, foams, magnetorheological studies, and surface boundary conditions.

Other International Activities

The Microgravity Combustion Diagnostics Project, under the ATD Program, made good progress in infrared (IR) emission imaging, obtaining filtered, precise spectral slices. Combustion experiments of ignition and flame spread over solid fuels radiatively ignited and involving a forced convection (Tigre), were run jointly with Japanese investigators. These tests were performed in the Japanese 10-sec drop tower facility. There are plans to use similar instruments in rocket flight experiments.

Spectral slicing is comparable to tomographic examination in which the spatial data relate to instantaneous composition. This gives temporal evolution of combustion features such as spread rates, char fronts, temperature, and the spatial extent and propagation of the front itself. This technology, developed under the ATD Program, also is included in plans for the Fluids and Combustion Facility for the *ISS*.

As more cooperative technology development opportunities present themselves and more data become available to support benefits resulting from the individual international agreements, an integrated international technology development program can be established. With the focus on enabling and enhancing microgravity science, this program will be tailored very carefully to assure maximum return on investment and yet preserve the national interests and competitiveness of all participating countries.

2.7

Advanced Technology Development Program

The primary goal of the ATD Program is to develop technology that will enable new types of scientific investigations. This goal is accomplished by enhancing the capability

and quality of MSAD's experimental hardware or by overcoming existing technology-based limitations identified in the MSAD science program. This goal recently has been augmented to satisfy technology needs of HEDS, which also have to be addressed by the ATD Program. The ATD Program achieves these goals by funding selected technology development projects at NASA Centers.

The ATD Program is intended to fund technology development through initial demonstration of feasibility and suitability for use in either the ground-based or flight programs. Once a sufficient level of maturity is demonstrated, further development (i.e., packaging or brass boarding) is the responsibility of an approved ground-based or flight project.

Examples of technologies suitable for development under the Program include, but are not limited to, the following: diagnostic instrumentation and measurement techniques that will benefit microgravity research; observational instrumentation and data recording methods (i.e., high-rate/high-resolution video); technology to enhance experiment operations such as advanced data handling, control, decision aids, and communication (i.e., remote operations); and technology designed to advance the state-of-the-art in hardware design, enabling new types of scientific investigations.

ATD projects also may be used to perform the following types of activities:

- Evaluate the capabilities of existing technologies to solve problems inherent in a generic class of microgravity hardware
- Assess the current state of the art in a particular technology that promises to enhance or expand current capabilities
- Develop novel technologies or adapt existing hardware or methodologies to meet the future needs of the microgravity science program, or to expand the potential for experimentation
- Demonstrate the technical maturity and readiness of the technology for incorporation into ground-based or flight experiments.

The ATD Program Review Panel is integral to the ATD Program. The Panel's responsibilities include: evaluation of progress in selected ATD projects at the annual program review, evaluation and recommendation of concept papers and proposals for funding, participation in selected final and intermediate project reviews, and development of

recommendations regarding the transition of the technology into flight projects. The Program Manager or MSAD Lead Scientist may invite additional technical experts to augment the panel during technical reviews.

The ATD Program structure and process are described in appendix B of NASA's *Microgravity Technology Report—Summary of Activities Through FY 1994* and in the current ATD Program Plan. The current ATD Program projects, and their progress in FY 1996, are described in appendix A of this report. Table 1 provides a summary of ATD Program metrics.

TABLE 1.—ATD Program metrics.

	FY 1994	FY 1995	FY 1996
Total Funding	\$1,679,000	\$2,714,000	\$2,468,000
Number of Tasks	13	15	14
Proceeding Papers	6	9	2
Journal Articles	6	10	7
NASA Technical Briefs	1	5	5
Technical Presentations	11	11	9
Patents	0	1	2

2.8

Technology Transfer Programs

Several technology transfer activities continued in FY 1996, including bioreactor technologies, laser light scattering, surface light scattering, stereo imaging velocimetry (SIV), microwave processing, and electrostatic levitation technologies. Also included are laser induced incandescence and dynamic light scattering techniques.

Bioreactor Technologies

To accelerate the pace of technology transfer in the biotechnology areas begun under the NASA–NIH inter-agency agreement, two multidisciplinary research centers are currently supported: the Massachusetts Institute of Technology, in Cambridge, MA, and the Wistar Institute, in Philadelphia, PA. Through NASA–NIH cooperation, NASA has funded approximately 28 research proposals and has also supported NIH-approved researchers to test tissue samples in NASA bioreactors at NASA's JSC. This has proven to be a very important undertaking in getting researchers to test NASA technology and in gaining acceptance in the larger biomedical community. NASA and the NIH have established a bioreactor laboratory and cooperative effort that was initiated with the National Institute of Child Health and Human Development in the fall 1994.

As of FY 1996, great strides continued to be made as a result of this collaboration. This transfer of NASA's bio-reactor technology will promote AIDS research, using cultures of human tonsil, lung, adenoid, and lymph nodes to assess the infectivity of the HIV virus on these tissues. In addition, new technologies in microencapsulation and biomolecule recovery are currently under way.

Laser Light Scattering

In FY 1996, NASA's MSAD worked with the NIH National Eye Institute to develop an interagency agreement for cooperative efforts in this technology area (see section 2.5).

Laser light scattering is a technique generally used to characterize very small particles by size, shape, and tendency to associate. Researchers at NASA's LeRC working on this ATD project, have developed a miniature laser light scattering unit based on fiber-optic technology. This unit was developed to study microscopic particle behavior in fluid flow studies in space—a technology important to fundamental research, medical research, and materials processing. Much of the same technology will be used in a flight experiment scheduled to fly on the Russian space station *Mir*. The experiment, using colloidal particles, will study the process of gelation. LeRC is helping to design the *ISS* Fluids and Combustion Facility to accommodate laser light scattering experiments.

A number of the successful respondents to the NASA Research Announcement (NRA) for fluid physics have indicated in their proposals the intention to use light scattering instruments. The laser light scattering technology has also proven its value in PCG processes. LeRC researchers, working with the University of Alabama, are designing special "in the droplet" probes to be used in the PCG flight experiments. The team has also helped define another design that will perform simultaneous multi-angle scattering from proteins growing in gels. At press time, flight dates had not yet been assigned for these two experiments.

Outside of NASA, the most interest in this compact, low-power, solid-state light scattering instrument has been for its potential use as a diagnostic tool for cataracts (see section 2.5). The instrument appears to be ideal for quantification of cataract development and may help lead to a cure for this common disease. This aspect of laser light scattering is being very ably pursued in cooperation with NIH. The Microgravity Program is currently working with the NIH National Eye Institute to transfer NASA technology involving the use of laser light scattering to detect early signs of the onset of cataract formation. A commercial concern,

International Development and Energy Associates of Beltsville, MD, has requested that LeRC design an instrument for the study of PCG on Earth. This work is funded by the NIH. Early in the laser light scattering ATD work, LeRC arranged with Brookhaven Instruments Company for the manufacture of a compact correlator. The correlator, which at that time was a steamer-trunk-sized computer, was reduced to a single personal computer insertable board.

Surface Light Scattering

In the process of surface light scattering, thermally activated ripples on the surface of liquids are used to measure viscosity and surface energy. This technology is being advanced by a team of collaborators from LeRC and the Case Western Reserve University. The researchers can now reliably and rapidly measure surface energy and viscosity, without touching the liquid.

In FY 1996, the non-contact measurement of viscosity and surface energy was described in meetings held in Toledo, OH, and Minneapolis, MN. The Toledo meetings, held in conjunction with Edison Industrial Systems Center, resulted in a number of requests for demonstration of the apparatus and measurement of industry supplied samples. The paint industry is especially interested in non-contact viscosity measurement. The technology was also described in the Fluids and Materials Discipline Conferences. A separate portion of this development addressed high amplitudes of surface fluctuation; this development has been especially interesting to JPL for containerless fluid surface property measurement and to the University of Georgia for studying energy transfer modes in droplet cooling of hot surfaces. In FY 1996, several patent disclosures were filed.

Stereo Imaging Velocimetry

SIV is a new method, brought forward by LeRC, which permits the simultaneous quantitative measurement of flow velocities throughout the volume of a test cell.

In FY 1996, the SIV technology was described to industry in a series of meetings held in Toledo and Minneapolis. The University of Toledo requested that NASA consider placing a copy of the equipment at the university to serve the fluid flow characterization needs of northern Ohio. LeRC researchers also toured facilities of Toledo Molding and Die Co., to advise on potential applications of SIV. SIV may be of aid to this manufacturer in the design of air conditioning ducts.

Interaction with LTV Steel continued in FY 1996. The continuous casting process is physically modeled using transparent fluids seeded with density-matched particles. LTV has used the results of SIV measurements to successfully justify investment in new equipment for the continuous caster.

The ADF Corporation expressed a strong interest in commercializing the SIV technology. ADF provides diagnostic services to operators of wind tunnels and sees an advantage in using full-field three-dimensional velocimetry. The LeRC Technology Transfer Office sponsored a market survey at the request of ADF. The LeRC patent office began preparing a patent for SIV technologies.

Microwave Furnace Facility

A team of researchers at the JPL have developed advanced techniques for processing materials amenable to microwave heating. This technique has the novel effect of producing volumetric heating in many important materials. The new heating technique can be used for processing materials either in a contained or containerless space environment. The researchers also developed advanced theoretical models (under the ATD Program) that define experimental conditions required for improved processing of ceramics. These analytical models can accurately describe the microwave-material interactions taking place in the furnace and can predict the temperature profiles within spherical and cylindrical samples. The facility also allows heating of materials through very precise time-temperature profiles. The researchers at JPL are in the process of transferring this technology to the private sector.

During 1996, they finished tasks associated with four Technology Cooperation Agreements (TCA). During this last year, they also developed teaming arrangements with several companies under the JPL Technology Affiliates (TA) Program. They have successfully demonstrated a new microwave method for the chemical vapor deposition (CVD) of silicon carbide on a carbon core fiber in collaboration with the 3M Corp. This project is designed to reduce the cost of producing high-strength, high-temperature fibers for fabricating low-density composites. They also have teamed up with several oil and gas industrial partners to develop a new diamond cutter for drilling at higher temperatures in hard rock. This project will use microwaves to selectively heat and join diamond to a ceramic substrate.

Electrostatic Levitation Facility

The Electrostatic Levitation Facility was developed under MSAD's containerless materials processing program. A molten sample is isolated from container walls in a high vacuum by electrostatic levitation. Under such a condition, melts can achieve deeply undercooled states, reaching metastable liquid or solid phases. Some of important applications of this facility might be in the development of glass forming alloys and measurements of various thermophysical properties of titanium base alloys and nickel superalloys, which are known to be highly reactive with crucibles. Built around this electrostatic levitator are various novel techniques that allow thermophysical property measurements of molten metallic alloys and semiconductors. Exceeding capabilities of conventional containerless methods, this facility can measure accurate values of density, thermal expansion coefficient, surface tension, viscosity, specific heat capacity, and emissivities.

In FY 1996, JPL scientists pursued technology transfer activities with four companies under the TCA's. Among these, "Transfer of High Temperature Electrostatic Levitation Technology," in partnership with Space Systems/Loral (SS/L) has been successfully completed, with a new levitation system operating at Loral Space Systems Division, Palo Alto, CA. Like the instrument at JPL, the SS/L facility uses electrostatic forces to levitate specimens in a vacuum chamber, where a high-power IR laser heats and melts the specimens. By isolating a material from all environmental influences except radiation, the disturbances produced by container walls and impurities are removed, ensuring clear observation of the intrinsic behavior of a material. This instrument has already been used in collaboration with outside researchers to conduct studies on undercooling phenomena and mapping of TTT curves for various alloys.

The facility has been operating since June 1996, and is part of SS/L's microgravity laboratory. SS/L provides access for investigators who need this equipment. SS/L also is looking at the commercial applications of this technology, and already is working with several universities and private companies to develop novel measurement techniques based on electrostatic levitation.

The TCA with MEMC Electronic Materials, Inc., on "Thermophysical Properties of Molten Silicon" was completed, with measurements of thermophysical properties of pure silicon as well as a boron-doped silicon melts.

The TCA on “Thermophysical Property Measurements of Glass Forming Alloys,” with Amorphous Technologies International, also is near completion. Thermophysical properties have been measured during glass-formation processes for alloys with several different compositions. In addition, the effect of surface oxides on glass formation also has been studied. Three papers were submitted for publication in refereed journals, and several more papers are being prepared.

The TCA on “Commercialization of the High Temperature Electrostatic Levitator,” with Theta Industries, Inc., is in progress. Continued technology transfer activities with these and two other companies through the JPL Technology Affiliates Program are under negotiation.

In FY 1996, two new technology transfer activities began emerging from the work performed under the ATD Program: laser induced incandescence and dynamic light scattering with suppression of multiple scattering.

Laser Induced Incandescence

Quantitative data obtained by advanced diagnostics are often needed to test the detailed predictions in numerical modeling and provide new knowledge of microgravity combustion science. In response to this need for advanced diagnostics, and with recognition of the constraints of a microgravity environment, LII is being developed as a two-dimensional imaging diagnostic for the measurement of soot volume fraction in microgravity combustion research. LII, in conjunction with other optical imaging techniques, provides unparalleled temporal and spatial resolution, yielding

sensitivity and insight into soot formation and oxidation processes.

In FY 1996, the researchers from the prime facility for Air Force testing of aircraft engines visited LeRC to discuss the LII technology. The Air Force would like to acquire an access to the technology for soot measurements of gas turbine engines being tested. Soot formation in jet engines leads to undesirable higher metal temperatures and may make the plane more visible to IR seeking missiles. Also, the Cabot Corp. supplied LeRC with samples for analysis of the carbon black particle size and degree of agglomeration.

Dynamic Light Scattering With Suppression of Multiple Scattering

In this project, an instrument will be developed and demonstrated that uses cross correlation of scattered laser light to discriminate against multiply scattered photons and select singly scattered light. This will allow particle size characterization in media so turbid that the conventional light scattering methods yield significantly undersized results.

Although this project did not officially start until FY 1997, some precursor work was reported at several national and international conferences and meetings. As a result of these meetings, a domestic company expressed specific interest in licensing the multiple scattering suppression technology.

Table 2 provides a summary of FY 1996 Technology Transfer Program metrics. For comparison, FY 1995 metrics are given in table 3.

TABLE 2.—FY 1996 Technology Transfer Program metrics.

Activity	Center	TCA's	CRADA's	Transfer to Flight Project	Other Contracts	Patents
Laser Light Scattering	LeRC	0	0	6	0	0
Stereo Imagining	LeRC	0	0	1	1	0
Surface Light Scattering	LeRC	0	0	0	0	1 (P)
Electrostatic Levitation	JPL	0	0	0	3 (P)	0
Microwave Processing	JPL	0	0	0	4 (P)	0
Bioreactor Technology	JSC	0	0	1	5	6
Totals		0	0	8	6, 7 (P)	6, 1 (P)

CRADA—Cooperative Research and Development Agreement

P—Pending

TCA—Technology Cooperation Agreement

TABLE 3.—FY 1995 Technology Transfer Program metrics.

Activity	Center	TCA's	CRADA's	Transfer to Flight Project	Other Contracts	Patents
Laser Light Scattering	LeRC	0	0	7	0	0
Stereo Imagining	LeRC	1	0	0	2	0
Surface Light Scattering	LeRC	0	0	1	2	0
Advanced Furnace Technology	LeRC	0	0	1	2	0
Electrostatic Levitation	JPL	4	0	0	3 (P)	0
Microwave Processing	JPL	4	0	0	2 (P)	0
Bioreactor Technology	JSC	0	0	1	3	1, 5 (P)
Totals		9	0	10	9, 5 (P)	1, 5 (P)

CRADA—Cooperative Research and Development Agreement

P—Pending

TCA—Technology Cooperation Agreement

Microgravity Science Research Programs and Related Technology Developments and Requirements

This section lists major technology developments in FY 1996, accomplished through research programs and under the ATD Program, as well as the current new technology requirements dictated by microgravity science needs. Brief descriptions of the developed technologies and new requirements are included in appendix B.

3.1 *Biotechnology*

The goal of the MSAD microgravity biotechnology program is to use the space environment to identify and quantitatively understand protein structure and processes controlling PCG and cell/tissue culturing. Under this

program, NASA sponsors research leading to improvements in the control and yield of techniques in these areas and contributes to major developments of medical, pharmaceutical, and agricultural technologies and products. MSFC is the Lead Center in the areas of PCG and separation technologies, supported by JSC in the areas of bioreactor and tissue culture technologies.

3.1.1 *Technologies*

The major technologies developed in the microgravity biotechnology program are listed in table 4. For further details, see appendix B, section B.1.1.

TABLE 4.—*Microgravity biotechnology program technologies.*

Technology	Title	Start Date	End Date
3.1.1.1	Protein Crystal Growth Vapor-Diffusion Flight Hardware and Facility	1993	1997
3.1.1.2	Protein Crystal Growth in Microgravity	1993	1998
3.1.1.3	Membrane Transport Phenomena	1995	1998
3.1.1.4	An Observable Protein Crystal Growth Flight Apparatus	1993	1998
3.1.1.5	Enhanced Dewar Program	1995	1999
3.1.1.6	Investigation of Protein Crystal Growth Mechanisms in Microgravity	1995	1998
3.1.1.7	Advanced High Brilliance X-Ray Source	1993	1996
3.1.1.8	Rotating Vessel Wall Perfused Bioreactors Technologies	1987	1997
3.1.1.9	Experimental Control Computer System	1992	1996
3.1.1.10*	Crystal Growth Instrumentation Development: A Protein Crystal Growth Studies Cell	1994	1996
3.1.1.11	Microencapsulation of Drugs	1996	2000
3.1.1.12*	Space Bioreactor Bioproduct Recovery System	1996	2000
3.1.1.13	Sensor Technology	1994	2000

* Developed under the ATD Program.

3.1.2

New Technology Requirements

Priority new technology requirements include the following:

- 3.1.2.1 New Optical Technique for Protein Crystal Growth Diagnostics
- 3.1.2.2 Development of Improved Rotating Wall Perfused Vessel Bioreactors
- 3.1.2.3 Development of Alternate Bioreactor Systems for Culturing Mammalian Cells and Tissues in Space
- 3.1.2.4 Cell/Tissue Metabolism Sensor and Control Subsystems
- 3.1.2.5 Advanced Media/Nutrient Supply and Replenishment Subsystems
- 3.1.2.6 Development of Microgravity-Based Bioreactor Systems Technologies
- 3.1.2.7 Cell/Tissue Oxygenation and Waste Gas Removal Subsystems
- 3.1.2.8 Development of a Thermally Controlled Sample/Experiment Storage System.

See section B.1.2 in appendix B for more details.

3.2

Combustion Science

The objectives of the MSAD combustion science research program focus on obtaining deeper understanding of combustion processes, including ignition, propagation, and extinction of various types of flames under low-gravity (low-g) conditions. This program brings fresh insights to important problems such as fire safety in space and on the ground. Since combustion accounts for a preponderance of the world's electrical power generation and provides the energy for nearly all modes of transport for goods and people, including spacecraft, this program also has significant potential for increasing energy utilization efficiency and reducing production of combustion-generated pollution. In addition, combustion processes are now being used in synthesis of novel materials. Microgravity research in this area offers potential for development of understanding of

such processes, with replacement of current trial-and-error approaches. LeRC is the Lead Center for combustion science discipline research.

3.2.1

Technologies

The major technologies developed in the microgravity combustion science program are listed in table 5. For details, see appendix B, section B.2.1.

TABLE 5.—*Microgravity combustion science program technologies.*

Technology	Title	Start Date	End Date
3.2.1.1	Light Sheet Flow Visualization and/or Velocimetry	1994	1996
3.2.1.2	Laser Doppler Velocimetry	1994	1996
3.2.1.3*	Microgravity Combustion Diagnostics	1987	1996
3.2.1.4*	Determination of Soot Volume Fraction via Laser-Induced Incandescence	1994	1997

* Developed under the ATD Program.

3.2.2

New Technology Requirements

Priority new technology requirements include the following:

- 3.2.2.1 Soot Temperature Measurements Using Pyrometric Techniques
- 3.2.2.2 Liquid Surface Temperature and Vapor Phase Concentration Measurements via Exciplex Fluorescence
- 3.2.2.3 Liquid Phase Thermometry and Fluorescence of Aromatics.

See section B.2.2 in appendix B for more details.

3.3

Fluid Physics

The objective of the microgravity fluid physics science discipline is to conduct a comprehensive research program on fluid dynamics and transport phenomena in which fundamental behavior is limited or affected by the presence of gravity, and where low-gravity experiments allow insight into that behavior. For example, a low-gravity environment results in greatly reduced density-driven convection flows and allows the study of other forms of convection such as flows driven by surface tension gradients, magneto/electrodynamics, or other interfacial phenomena. Investigations of these phenomena result in the basic scientific and practical knowledge needed to design effective and reliable space-based systems and facilities that rely on fluid processes.

Another objective of the fluid physics program is to assist other microgravity disciplines, such as materials science and combustion science, by developing an understanding of the gravity-dependent fluid phenomena that underlie their experiment observations. LeRC is the Lead Center for the fluid physics discipline research.

3.3.1

Technologies

The major technologies developed in fluid physics science are listed in table 6. For further details, see appendix B, section B.3.1.

3.3.2

New Technology Requirements

Priority new technology requirements include the following:

- 3.3.2.1 High-Resolution, High-Frame-Rate Video
- 3.3.2.2 Improved Data Storage and Downlink Technologies
- 3.3.2.3 Three-Dimensional Particle Tracking
- 3.3.2.4 Diagnostics Technologies for Opaque Fluids (e.g., “Melts”)

- 3.3.2.5 Nonintrusive Three-Dimensional Full Field Fluid Velocity Measurement Device
- 3.3.2.6 Nonintrusive Three-Dimensional Full Field Fluid Temperature Measurement Device
- 3.3.2.7 Ultrasonic Phase Distribution Measurement for Multiphase Flows Through an Opaque Tube
- 3.3.2.8 Nonintrusive Digital Pattern Recognition and Phase-Boundary Locator
- 3.3.2.9 Nonintrusive Three-Dimensional Surface Shape Measurement With Sub-Micron Measurement Capability
- 3.3.2.10 Improved Twyman-Green Interferometer With 1/30 Wavelength Resolution Capability.

See section B.3.2 in appendix B for more information.

TABLE 6.—*Microgravity fluid physics program technologies.*

Technology	Title	Start Date	End Date
3.3.1.1	Mechanics of Granular Materials	1978	1998
3.3.1.2*	Stereo Imaging Velocimeter	1992	1996
3.3.1.3*	Laser Feedback Interferometer	1994	1997
3.3.1.4*	Passive Free-Vortex Separator	1996	1999
3.3.1.5*	Surface Fluctuation Spectrometers	1996	1997

* Developed under the ATD Program.

3.4

Fundamental Physics

The objective of the MSAD selected studies in fundamental physics is to provide the opportunities to test fundamental scientific theories to a level of accuracy not possible in the gravity of Earth's environment. This program encompasses research on transient and equilibrium critical phenomena, as well as other thermo-physical measurements of interest in condensed matter physics, relativistic physics, and atomic physics using laser cooling technologies and quantum crystals. JPL is the Lead Center for fundamental physics research.

3.4.1

Technologies

Technologies developed in the microgravity fundamental physics are listed in table 7. For more details, see appendix B, section B.4.1.

3.4.2

New Technology Requirements

The priority new technology requirements include the following:

- 3.4.2.1 Digital Signal Processing (DSP) SQUID Technology
- 3.4.2.2 Improved Flight-Quality Radio Frequency SQUID System
- 3.4.2.3 Improved High-Resolution Pressure Transducer
- 3.4.2.4 Vibration Isolation for Cryogenic Systems
- 3.4.2.5 Precise Thin Film Lithography on Cylindrical Surfaces
- 3.4.2.6 Long Lifetime Cryogenics Systems for the ISS Facility
- 3.4.2.7 Miniaturized High-Resolution Thermometers
- 3.4.2.8 Flight-Qualified Technology and Instrumentation for Laser Cooling of Atoms

- 3.4.2.9 Visual Access Cryogenic System or Cryogenic High-Speed Video Camera
- 3.4.2.10 Flight-Quality Direct Current SQUID System
- 3.4.2.11 Flight-Quality DSP SQUID's
- 3.4.2.12 Ultra-High Vacuum Production and Measurement Techniques
- 3.4.2.13 Multiple Experiment Platform for Low-Temperature Physics Experiments
- 3.4.2.14 Low-Noise Cryo-Coolers
- 3.4.2.15 Flight-Quality Dilution Refrigerator
- 3.4.2.16 Flight-Qualified GdCl₃ Thermometer
- 3.4.2.17 Flight-Quality Laser Cooled Atom Trap Facility
- 3.4.2.18 Flight-Qualified ³He Refrigerator
- 3.4.2.19 Accelerometers for Use at Helium Temperatures
- 3.4.2.20 Fast Response High-Resolution Thermometer
- 3.4.2.21 Ultra-Sensitive Superconducting Test Mass Accelerometers
- 3.4.2.22 Miniature High-Reliability, Low-Temperature Valve
- 3.4.2.23 Flight Quality Ultra-Stable Frequency Standard
- 3.4.2.24 High-Precision Germanium Thermometer Readout and Temperature Controller
- 3.4.2.25 Low-Noise Cryogenic Instrumentation Amplifiers
- 3.4.2.26 Telescience Flight Software Tools.

See section B.4.2 in appendix B for more information.

TABLE 7.—*Fundamental physics program technologies.*

Technology	Title	Start Date	End Date
3.4.1.1	Copper Ammonium Bromide (CAB) High Resolution Thermometers	1985	1997
3.4.1.2	Compact, Inexpensive High Field Gradient Superconducting Magnets	1993	1996
3.4.1.3*	High Resolution Capacitive Pressure Transducer	1994	1996
3.4.1.5*	High-Resolution Thermometry and Improved Squid Readout	1994	1996
3.4.1.6	Prototype Miniature High-Resolution Thermometer	1995	1996
3.4.1.7	Magnetic Levitator for Liquid Helium	1994	1996
3.4.1.8	Electrostatic Levitator for Liquid Helium Drops	1993	1996
3.4.1.9*	Magnetostrictive Low-Temperature Actuators	1996	1999
3.4.1.10	Ultrasensitive Superconducting Test Mass Accelerometers	1990	1998
3.4.1.11	Measurement of Ultra-Low Pressure at Low Temperature	1996	1997

* Developed under the ATD Program.

3.5 *Materials Science*

The goal of the microgravity materials science program is to use the microgravity environment to seek and understand quantitatively the cause-and-effect relationships among the processing, properties, and structure of materials. Of particular interest is understanding the role of gravity-driven convection in the processing of the electronic and photonic materials, metals, alloys, composites, glasses, ceramics, and polymers. This research will help scientists better understand materials and materials processing, and it may result in improvements to production methods and materials on Earth. NASA's MSFC is the Lead Center for materials science discipline research.

3.5.1 *Technologies*

The major technologies developed in materials science are listed in table 8. For further details, see appendix B, section B.5.1.

3.5.2 *New Technology Requirement*

The priority new technology requirement is:

- 3.5.2.1 Development of a Test Facility for Seebeck Solidification Experiments.

Section B.5.2 in appendix B provides further details.

TABLE 8.—*Microgravity materials science program technologies.*

Technology	Title	Start Date	End Date
3.5.1.1	Coupled Growth in Hypermonotectics	1993	1998
3.5.1.2	Effects on Nucleation by Containerless Processing	1990	1998
3.5.1.3	Alloy Undercooling Experiments in Microgravity Environment	1990	1997
3.5.1.4	Thermophysical Properties of Metallic Glasses and Undercooled Alloys	1992	1997
3.5.1.5	Orbital Processing of High-Quality Cadmium Telluride	1990	1997
3.5.1.6	Growth of Solid Solution Single Crystals	1994	1997
3.5.1.7	Crystal Growth of II–IV Semiconducting Alloys by Directional Solidification	1992	1997
3.5.1.8	The Study of Dopant Segregation Behavior During the Growth of GaAs in Microgravity	1992	1997
3.5.1.9	Temperature Dependence of Diffusivities in Liquid Metals	1993	1998
3.5.1.10	Particle Engulfment and Pushing by Solidifying Interfaces	1993	1998
3.5.1.11	Crystal Growth of ZnSe and Related Ternary Compound Semiconductors by Physical Vapor Transport	1993	1996
3.5.1.12	Measurement of Viscosity and Surface Tension of Undercooled Melts	1990	1998
3.5.1.13	Test of Magnetic Damping of Convective Flows in Microgravity	1992	1997
3.5.1.14*	Real-Time X-Ray Microscopy for Solidification Processing	1994	1997
3.5.1.15*	Advanced Heat Pipe Technology for Furnace Element Design	1994	1996
3.5.1.16*	Ceramic Cartridges via Sintering and Vacuum Plasma	1993	1997

* Developed under the ATD Program.

3.6 *Multidiscipline Technology*

3.6.1 *Technology*

The technology developed under the ATD Program to support multiple science disciplines is shown in table 9. Further details may be found in appendix B, section B.6.1.

3.6.2 *New Technology Requirement*

The priority new technology requirement is:

3.6.2.1. Miniature Microscope.

Further details are available in appendix B, section B.6.2.

TABLE 9.—*Multiple science disciplines technology.*

Technology	Title	Start Date	End Date
3.6.1.1*	Free Float Trajectory Management	1995	1998

•Developed under the ATD Program

Appendix A

***FY 1996 Advanced Technology Development
Program and Project Descriptions***

Program Description

Experience with microgravity research has shown that technology limitations generally emerge during experiment development and hardware design. In order to address these limitations, MSAD has implemented the ATD Program.

The ATD Program's main goal is to develop technology that will enable new types of scientific investigations and advance current research. This is accomplished by enhancing the capability and quality of current experimental hardware and by overcoming existing technology-based limitations identified in MSAD's Microgravity Science Research Program.

The ATD Program anticipates the needs of microgravity researchers and provides for the development of dynamic state-of-the-art technology before it is needed on the critical paths of specific flight programs. This research already has provided numerous advances and breakthroughs in experiment techniques, sensor technology, and precise measurement ability. ATD projects are funded through an initial demonstration of feasibility and suitability for use in either the ground-based or flight programs.

ATD Program application and acceptance is a two-step review process. For more information, contact:

Isabella Kierk
Program Manager for Technology
Development and Transfer
NASA JPL
4800 Oak Grove Drive
Pasadena, CA 91109-8099

Phone: (818) 354-1879
E-mail: Isabella.Kierk@jpl.nasa.gov

Project Descriptions

Low-Temperature Magnetostrictive Smart Actuator Mechanisms

Objectives

In the first phase of this task, new high-power, long-stroke magnetostrictive materials for use at low temperature are being developed and characterized. These materials are "giant magnetostrictors" of terbium and dysprosium, with strokes up to 1 percent of crystal length. In later phases of the task, applications will be developed for the practical deployment of magnetostrictive crystals as actuators in experimental apparatus such as liquid helium valves, cryogenic heat switches, linear actuators for variable volume calorimeters, and other devices used by PI's in the fields of microgravity and condensed-matter physics.

FY 1996 was the first year of a 4-yr effort. There are three goals for this fiscal year: to develop magnetostrictive material, to build a cryogenic dilatometer (see fig. 1), and to design and build a liquid helium valve. The central goals in material applications for the project are as follows: to develop usable magnetostrictive actuated valves, heat switches, and linear positioners; to make these devices available to microgravity PI's during the course of the development effort; and to encourage and foster relationships with commercial instrument builders who have expressed an interest in these magnetostrictive devices. The commercialization of these devices is expected to make them more available to PI's in the program at costs lower than that of single-unit production in the laboratory.

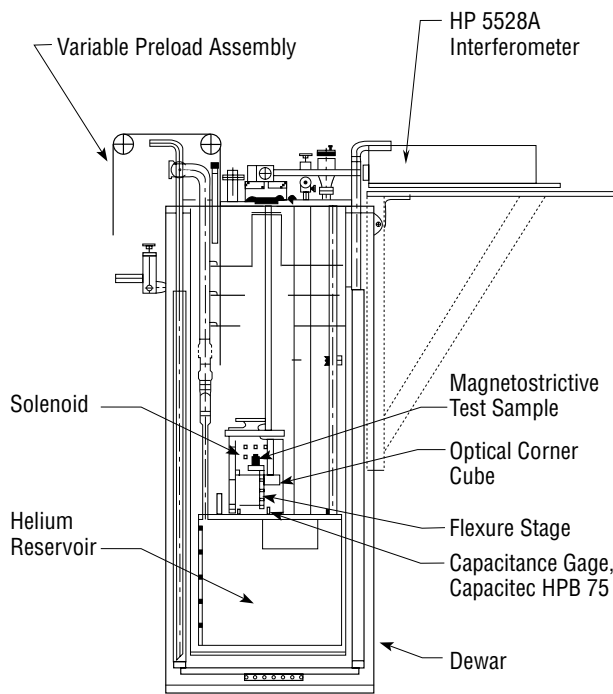

FIGURE 1.—Cryogenic dilatometer for measurement of variations in magnetostrictive crystal length to 0.25-micron accuracy.

Method

The planned approach has two phases: (1) the development of magnetostrictive material, and (2) application development. The task is presently in the material development phase, for which a new material of terbium, dysprosium, and zinc has been designed. This new magnetostrictive material has more desirable properties than previous samples, which consisted of terbium and dysprosium only. The terbium dysprosium zinc material is an enhanced material in that it may be grown faster, more predictably, and at lower cost than the previous materials. It also has more desirable mechanical properties, such as enhanced machinability and greater hardness.

A further development in magnetostrictive material fabrication is under study. Major opportunities for the commercialization of low-temperature giant magnetostriction will be created if the cost of preparing the samples can be reduced significantly from present levels. There is strong evidence that such a reduction in cost is possible if a polycrystalline material is used in place of a single-crystal material. Building on earlier work published by A.E. Clark, Dr. Brent Fultz (California Institute of Technology), and members of the ATD project staff assessed this approach. A high degree of crystal alignment in terbium and dysprosium

may be obtained through the action of a rolling mill and subsequent heat treating. The rolling mill method produces a sample with approximately two-thirds the stroke of present samples, which is no limitation for many applications and which may be compensated for entirely by increasing sample length. The approach is of central interest to the material development portion of this project because of its potential for reducing actuator cost to a level at which commercialization is quite feasible.

Another activity was the design and development of instrumentation to be used over the next several years in the analysis of both the new materials and the devices based upon them. The first device required is a cryogenic dilatometer for investigating the magnetostrictive properties of a single sample, given variable preload. This dilatometer is nearing completion. The interferometer subsystem has been tested and is seen to be stable with respect to vibration. The lowest reliable digit of measurement is 0.25 micron, providing a 0.2-percent measurement of crystal stroke. A sample preload system has also been fabricated and assembled. Full system integration and the first material tests will be performed in June 1996.

The rolling mill approach to sample fabrication produces a larger number of samples than can be tested at reasonable cost in the cryogenic dilatometer described above. Therefore, a second, more cost-effective measurement device, which contains an open-bore probe with a helium-cooled magnet configured so that many samples can be run without warming the magnet assembly, is also in fabrication.

Schedule and Milestones

A sample of the terbium dysprosium zinc material was sent to NASA's JPL for testing in June 1996, and fixturing and assembly of a solenoid with the sample installed were completed. Cryogenic valve design and construction is under way and will be completed during FY 1997. The team is making an effort to understand and improve the present level of laboratory practice in preparing liquid and superfluid helium valves. These valves continue to be a source of difficulties for PI's in the program, and even the more successful designs have very short lives. Magnetostrictive drive will enhance the effectiveness of these valves.

Analysis of existing valves in use by PI's at JPL, the University of New Mexico, and Stanford University has been done. This analysis included microscope photographs of distortion patterns in existing valve seats. A finite element analysis of strains in the diaphragms and seats of an existing valve design was begun and corroborated with empirical

results. Sourcing of vendors of valve seat components with extremely good surface finishes was completed, and a valve seat designer with experience with helium valves and cold propellants was located.

Application and Technology Transfer

The development of magnetostrictive materials into liquid helium valve actuators, cryogenic heat switches, linear actuators for variable volume calorimeters, and other devices is a central part of this applications-oriented ATD task. These devices will be delivered to PI's in the program for evaluation and testing. Commercial interest also is being

cultivated. One application in which there has been significant commercial interest is the flow regulation of ^3He for the closed-loop temperature control of a dilution refrigerator.

Researcher and Development Center

Dr. Robert Chave
NASA JPL
Mail Stop 79-24
4800 Oak Grove Drive
Pasadena, CA 91109-8099

Phone: (818) 393-2556
E-mail: rchave@squid.jpl.nasa.gov

Advancement of Solidification Processing Through Real-Time X-Ray Microscopy

Objectives

Physical processes that occur at or near the solid-liquid interface during solidification or other phase transformations partially determine important properties of solids. To date, interfacial morphologies and particle-interface interactions in metallic, optically opaque systems have been deduced from post-process metallographic analyses of specimens.

Thus, little information about the detailed dynamics of the processes has been obtained. A high-resolution x-ray microscope is being developed to view, in situ and in real time, interfacial processes in metallic systems during freezing. The X-Ray Transmission Microscope (XTM) operates in the hard x-ray range (10 to 100 keV) and achieves magnification through projection. Using select aluminum alloys, in situ records have been obtained of the evolution of interface morphologies with characteristic lengths as small as 25 microns, interfacial solute accumulation (see figs. 2 and 3), and the formation of droplets. In order to improve these capabilities, this ATD employs the latest technologies in hard x-ray imaging detection and addresses the complex issues of resolution, contrast, and minimal exposure time.

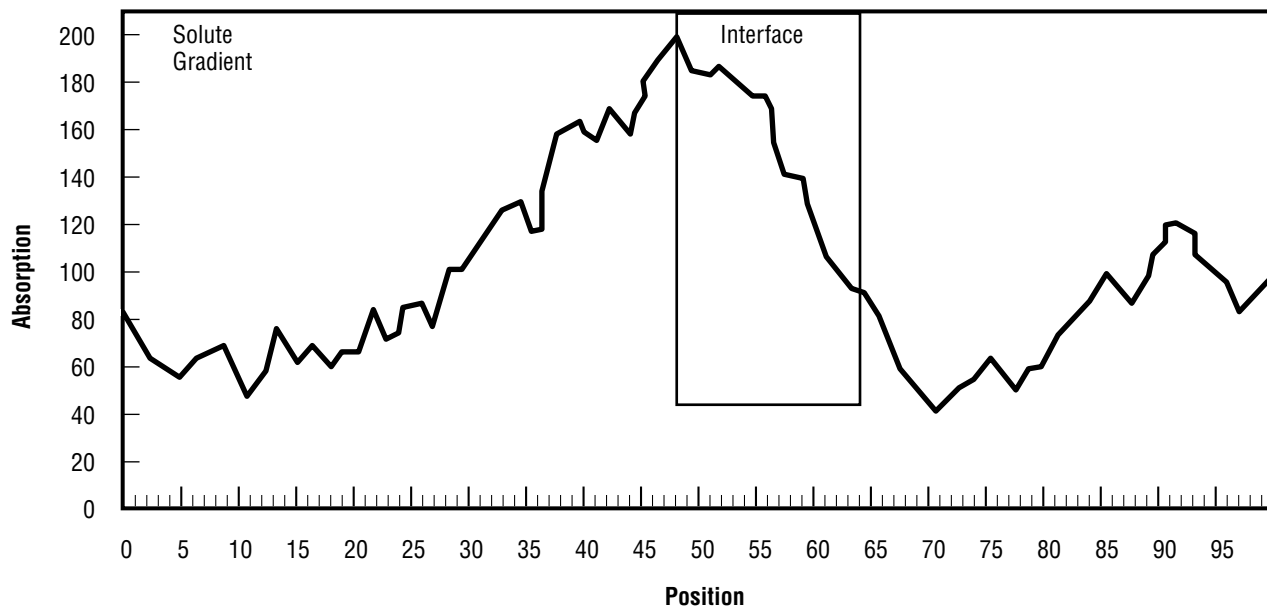

FIGURE 2.—Optical intensity (absorption) profile along the line in figure 3 crossing the solute layer and interface. Solute gradient is clearly seen on the left part of the graph. Increasing indium content represents increased absorption. The diffuse interface region is in the marked area. Note the solute layer is not uniform along the length of the interface.

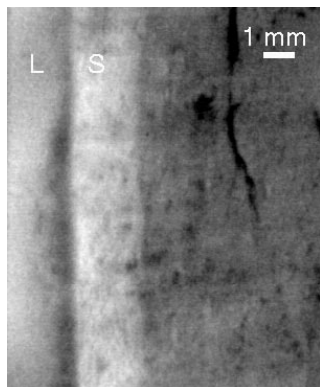

FIGURE 3.—Solid-liquid interface of Al-18 In, growing at 12.4 microns/sec in a 45 °C/cm temperature gradient and showing solute rejection to the liquid after the step increase of translation rate.

During this ATD, the following capabilities have been demonstrated with the XTM during solidification with an x-ray-transparent directional solidification furnace:

- A resolution of 25 microns for certain features.
- Solidification rates of 0.3 to 120.0 microns/sec.
- Temperatures up to 900 °C, with temperature gradients of up to 50 °C/cm.
- Contrast sensitivities sufficient to detect 2-percent difference in absorptance.
- Exposure times of less than 2 sec.

Method

With metallic and semiconducting samples, the penetration of macroscopic layers requires photon energies in excess of 10 keV. This precludes the use of optical approaches for imaging; only projection radiography can be practically employed in this energy range. Projection radiography uses the divergence of the beam from a small source, the diameter of which limits the ultimate resolution. Hence, x-ray projection radiography requires micro-focus x-ray tubes. The XTM utilized the smallest source available (<1 micron), and the measured ultimate resolution is better than 2 microns.

The major components of the system consist of a metal sample, with a thickness on the order of 1 mm, contained in a specially designed high-transmittance crucible. A high-temperature furnace on a translation stage imposes a temperature gradient onto the sample. The solid-liquid interface is positioned in close proximity to the focal spot of a micro-focus x-ray source. The diverging x-ray beam permeates the sample, and the resulting shadow falls on an x-ray image converter. The resulting visible image is then converted to a digital image by a charge-coupled device (CCD) camera and stored in a computer. This image is displayed on a high-resolution monitor, either in real time or after further processing (contrast enhancement, filtering, etc.).

At typical solidification rates, motion-induced blurring limits exposure time to a few seconds. With state-of-the-art x-ray image intensifier/camera combinations, detector magnification of some 20× is the minimum required to obtain a spatial resolution of 10 microns. Such resolution is necessary to see the dendritic structures formed in solidifying metals. Of course, such observations require sufficient contrast, or difference in absorptance, between features to be resolved and retained by the imaging devices (image intensifier, camera, and recording device). Employing higher magnifications than required by simple resolution arguments enhanced detection of low-contrast features. In mono-component metallic systems, the contrast between solid and melt is determined by the electron cloud density of the two phases, resulting in <2 percent radiographic (image) contrast. In alloy systems, solute segregation can provide further contrast enhancement. Therefore, alloys are selected based on x-ray contrast, and the highest magnifications practicable are employed.

How much of the original image contrast is retained depends on the dynamic range of the detector (imaging train) and the size of the features in the object. For small-length scales, the contrast retained by the imaging train becomes much smaller than the original image contrast. This can only be partly compensated for if the dynamic range of the imaging train is high enough that the lowest intensities of interest remain above the noise of the system.

This research team has been using a conventional x-ray image intensifier coupled to a cooled visible-light CCD camera of 12–16 bits dynamic range. The intensifier offers, at best, a 10 bit dynamic range, or 1 part in 1,000. New CCD x-ray camera technology, using radiation-hardened CCD's as a direct-conversion hard x-ray detector, was evaluated. Comparisons between these and phosphor-coated CCD's were used to determine the best technologies to view the low-contrast details of solidification.

Schedule and Milestones

The final project review was completed in May 1996. All milestones for the ATD have been successfully completed: imaging of solidifying metals and metal matrix composites were completed 6 mo ahead of schedule; the advance x-ray camera was received May 1996 and has been tested; and selection of the advanced x-ray intensifier was completed in March 1996, with delivery expected in December 1996. This completes the technical objectives of the ATD.

Application and Technology Transfer

Research goals include studying the solidification of metals and semiconductors and examining the dispersion of reinforcement particles in composites. Features already observed include dendrites and cells, the effects of voids and particles on morphology during solidification of metal matrix composites, and solutal segregation profiles.

Researcher and Development Center

Dr. Peter Curreri
NASA MSFC
Marshall Space Flight Center, AL 35812

Phone: (205) 544-7763
E-mail: Peter.A.Curreri@msfc.nasa.gov

Advanced Heat Pipe Technology for Furnace Element Design in Spaceflight Applications

Objectives

This project focuses on two potentially important advances in heat pipe and furnace technology. The first is the development of a heat pipe that will operate as an isothermal furnace liner capable of processing materials at temperatures up to 1,500 °C. The isothermality and control associated with a heat pipe greatly exceeds that possible in traditional wire-wound furnaces, thus improving the quality of the thermal environment. Existing technology for isothermal liners limits the application to 1,100 °C, and extension to a higher temperature range will enable materials science experiments to be conducted under more favorable thermal conditions. Experiments contemplated for the higher range include crystal growth by solidification of high-temperature materials, such as cadmium telluride and gallium arsenide, and application to other advanced fabrication techniques, like liquid-phase sintering. The measurement of thermophysical properties, such as diffusion constants of dopants and thermal diffusivity in liquid

semi-conductors, including silicon, at well-controlled and isothermally maintained temperatures, is another important application. The isothermal furnace liner is intended for installation in a module of the Space Station Furnace Facility (SSFF) on the *ISS*, but it also has immediate application to ground-based studies, where precise control of temperature will be beneficial. Figure 4 shows a cutaway schematic of an isothermal furnace liner.

Method

A major concern in developing the high-temperature heat pipe is the need for selecting the materials for its successful construction. One of the first activities of the project was to review possible materials and examine their known history as conventional heat pipes. An extensive survey was made of a wide range of materials to determine the most appropriate and cost-effective approach to this project. Lithium was the clear choice for use as the working fluid. With a low melting point (181 °C) and vapor pressure just below atmospheric pressure at typical required operating temperatures, its properties are ideal. Furthermore, there is an adequate database chronicling its past use in heat-transfer applications within this temperature range. Although it is not

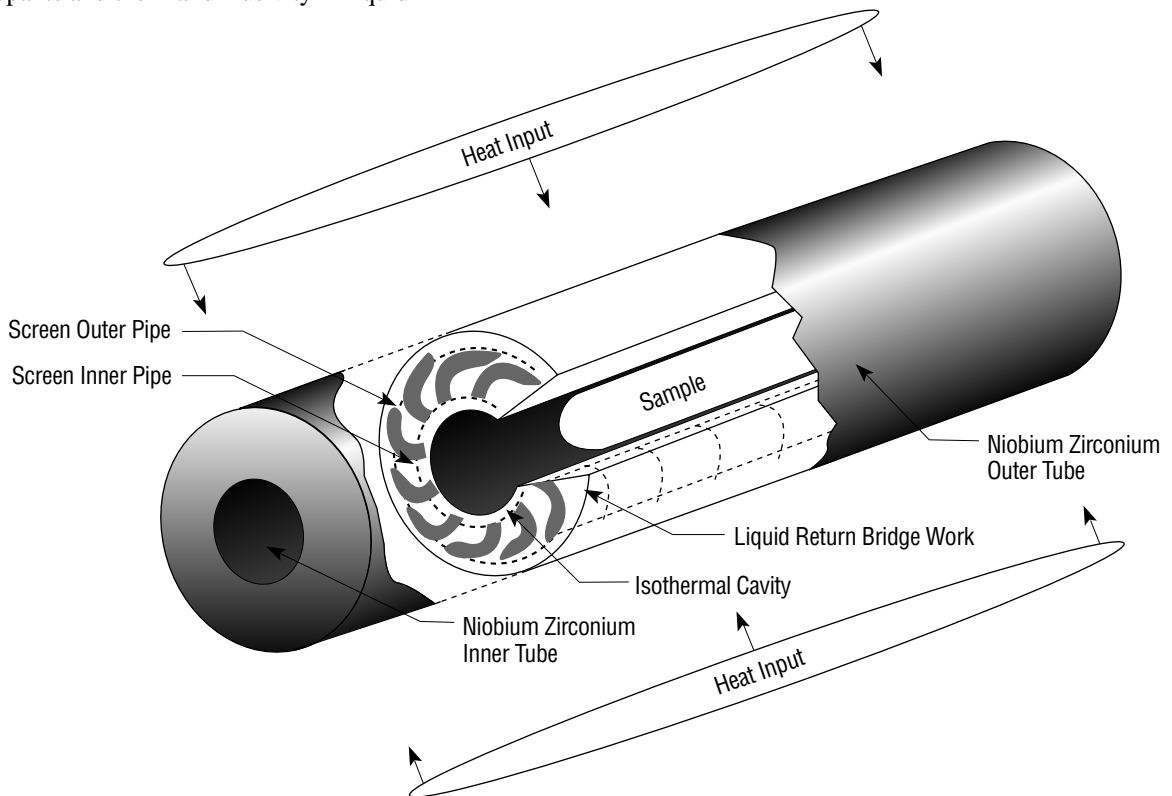

FIGURE 4.—Cutaway schematic of isothermal furnace liner.

a routinely used material, purification and loading techniques of lithium for heat pipe applications are well understood, and the technology is at a mature state.

After considerable materials evaluation, it was decided that a niobium-1 percent zirconium alloy would be the most suitable and cost-effective material for the body of the heat pipe. The evaluation took into account high-temperature and creep properties, reactivity, weldability, and formability. Another selection criterion was the availability of wire made from this alloy for use in fabricating the screen.

A second important issue was the design of the heat pipe, both from the standpoint of function and for fabrication and operational reasons. The isothermal furnace liner has a more complex geometry than the heat-transfer applications for which the heat pipe is conventionally used. This type of heat pipe, or isothermal liner, requires that the material being processed be maintained at a uniform temperature within a cavity. Therefore, the evaporator part of the heat pipe is on the outside section of an annular pipe, with the condenser at the inner section, and the wick structure is required to operate in two directions. The heat pipe assembly must first transfer sufficient heat to the condenser and maintain its temperature at a level equal to that of the evaporator. Secondly, it must maintain the same uniform temperature along the inner surface of the inside part of the inner section of the pipe. The desired heat transfer is in two dimensions, with a more complex circuit for the return of the condensed liquid to the evaporator. Therefore, the wick structure has to bridge the gap from the outer tube to the wall of the inner tube, thus enabling the liquid lithium to return to the condenser.

From a functional standpoint, facilitating the precise alignment of the load within the heat pipe necessitated an early design criterion specifying that this annular pipe be open at both ends, allowing one to view the positioning of the load both upon insertion and during any translation. Such a geometry puts considerably more strain on the welds that join the end caps to the main body of the heat pipe assembly. The anticipated temperature difference between the inner and outer surfaces of the pipe during heat-up will be high, particularly before the lithium vapor pressure is actively isothermalizing the assembly; thus, the potential for the welds to crack is also high. Suitable test articles have been fabricated, and extensive testing is presently under way. The goal is to produce heat pipes capable of operating within

0.75 °C of the required temperature over long periods of time (several days) and able to withstand many cycles between room and operating temperatures. These tests will culminate in the growing of crystals in a new facility.

Schedule and Milestones

This project, originated in FY 1995 and planned as a 4-yr effort, originally included the development of a moving-gradient heat pipe furnace. After the first year, however, the emphasis was changed, and the effort was exclusively devoted to the fabrication and testing of the high-temperature isothermal liner. To complement the development program, dialog to establish the protocol for incorporation of the liner as an integral part of a furnace module for the SSFF has been initiated. The remainder of the program will be devoted to extensive testing of the temperature uniformity of the inner surface of the heat pipe, the longevity of the heat pipe, and analysis of potential failure modes.

Application and Technology Transfer

The instrument presented here will have a considerable impact on materials science. While specifically aimed at supervised flight applications, benefits to ground-based research are equally substantial. A high-temperature heat pipe of the specifications described does not currently exist for crystal growth, and its development will immediately produce dividends for those growing crystals and conducting other materials science research in the 1,100–1,500 °C temperature range. In flight experiments, where investment per mission is high, it is essential that thermal conditions for experiments be optimized so that science returns can be maximized. It is also imperative that the apparatus be robust, operational, efficient, and safe. The development of this particular heat pipe is a major step toward reaching this goal.

Researcher and Development Center

Dr. Donald Gillies
NASA MSFC
Marshall Space Flight Center, AL 35812

Phone: (205) 544-9302
E-mail: Donald.C.Gillies@msfc.nasa.gov

Space Bioreactor Bioproduct Recovery System

Objectives

A major focus of MSAD's biotechnology program has been the development of space bioreactors that can be used aboard spacecraft to overcome gravity-induced limitations in cell culture and tissue engineering. The current generation of space bioreactors can support some aspects of long-duration cell cultures, but cannot be used to separate and preserve or remove the bioproducts. Some of the bioactive molecules present in trace quantities in the bioreactors are valuable, while other biomolecules present can act as cell inhibitors and either lead to termination of cellular production of desired molecules or to cell death.

The purpose of this effort is to develop a bioproduct recovery system (BRS) that allows the selective removal of molecules of interest from space bioreactors, thus enhancing the productivity of those bioreactors. Specifically, the BRS is designed to target specific biomolecules or waste products, to continuously adsorb and separate biomolecules from dilute bioreactor effluents, and to stabilize and preserve targeted bioproducts. The BRS will also be miniaturized to meet volume and power constraints and designed to operate in microgravity.

Method

The BRS is integrated into the space bioreactor perfusion loop, as illustrated in figure 5. Bioreactor fluid flows from the perfusion loop into the BRS cartridges, each of which is packed with an adsorbent that binds, separates, and retains substantial quantities of the bioproduct(s) of interest. During operation of the bioreactor, as the BRS cartridges become fully or partially saturated with target bioproducts, they can be removed for storage or processed further. Further processing may involve flushing the saturated cartridges with solutions that either remove degradative molecules or preserve and stabilize the bound bioproducts' integrity and activity.

The BRS concept revolves around two distinct systems: an on-line system, in which bioreactor media continuously flow through the BRS cartridges (fig. 6a); and a downstream system, in which spent media from the bioreactor flows in a single pass through the BRS cartridges (fig. 6b). Each BRS contains several adsorption cartridges that contain specific-affinity adsorbents for targeted biomolecules or waste

products. A circulation pump and pressure sensing devices are used to control the flow of liquid through the two systems.

Schedule and Milestones

This ATD project was funded for FY 1996. This year will result in the development of a bioproduct-recovery test-bed, which will include the selection and integration of bioreactors, flow and pressure subsystems, bioproduct recovery systems, and analytical systems. Cell cultures and bioproduct production experiments will be conducted with selected cells and tissues, and affinity-matrix systems for candidate bioproducts will be evaluated. Results from these efforts will be presented at scientific and technological meetings, as well as in future publications.

Application and Technology Transfer

The National Research Council has identified the need for separation and preservation technologies that allow the recovery of high-value biomolecules from dilute aqueous sources, such as bioreactors. In addition, the worldwide market for biotechnology-derived products is projected to exceed \$50 billion per year in the 21st century.

The processes and technologies being developed will drive new operational concepts, new materials and packaging, miniaturization, and new means of ensuring stability before and after use. Many of the technologies and processes developed will be used by MSAD-funded scientists as "enabling" technologies in the areas of basic biotechnology research products, disease diagnosis and therapy, and tissue engineering and creation of replacement tissues. The return of targeted biomolecules produced from long-term cultures aboard the *ISS* will allow the use of such molecules for research, and diagnostic and therapeutic applications in the medical, health-care, and biotechnology industries.

Researcher and Development Center

Dr. Steve R. Gonda
NASA JSC
Code SD4
2101 NASA Road 1
Houston, TX 77058

Phone: (713) 483-8745
E-mail: gonda@medics.jsc.nasa.gov

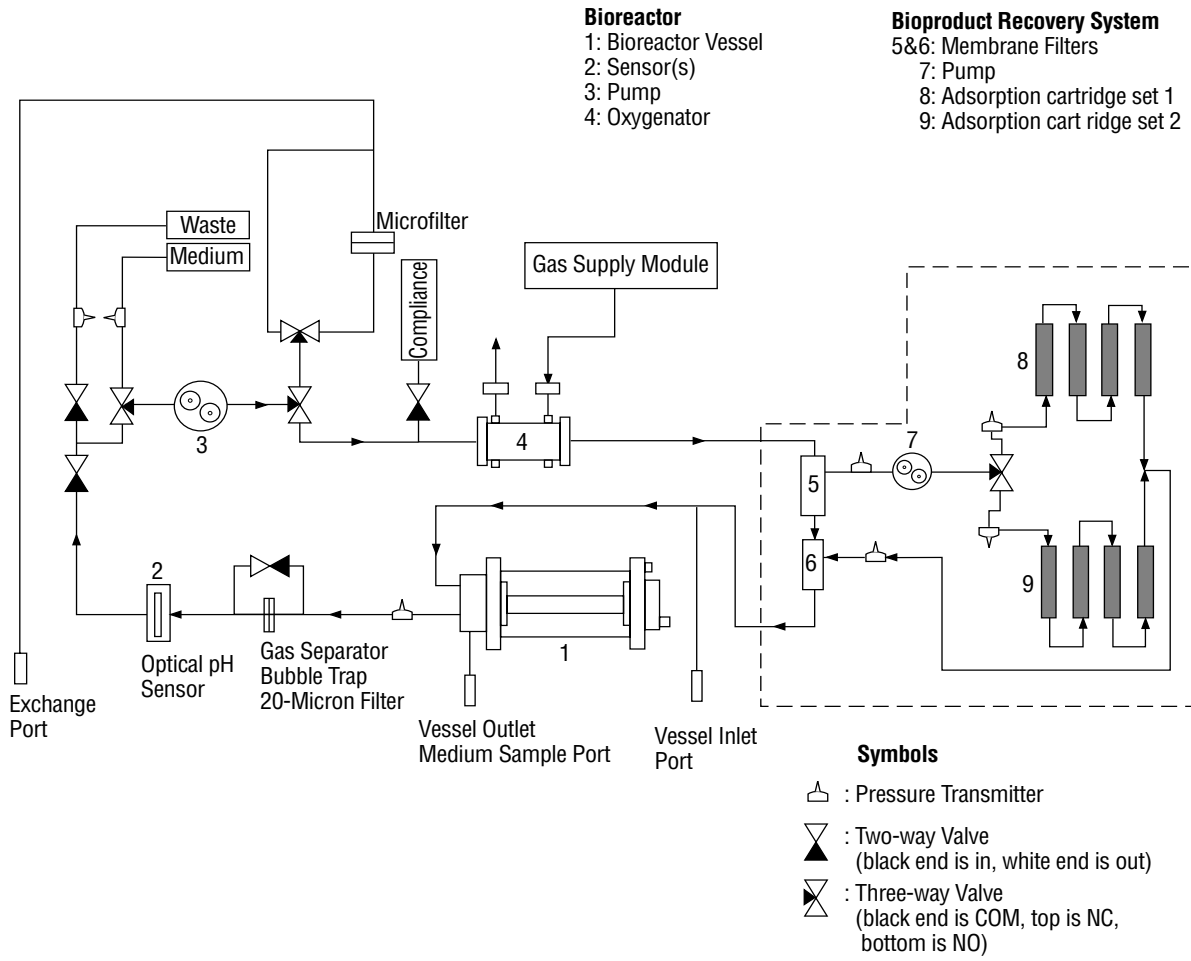

FIGURE 5.—On-line system test-bed.

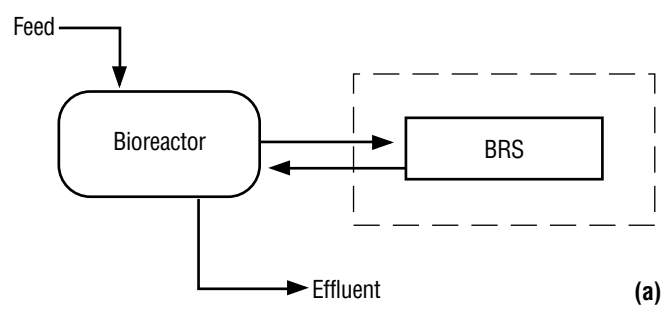

FIGURE 6a.—On-line separation system.

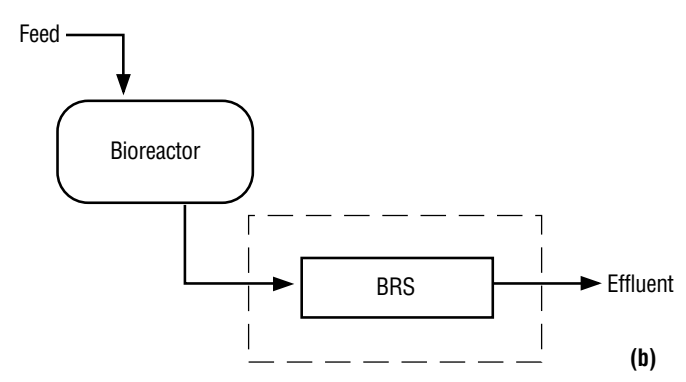

FIGURE 6b.—Downstream separation system.

Microgravity Combustion Diagnostics

Objectives

Explorations into the phenomena of basic combustion science in a microgravity environment demand the development of new techniques in the field of combustion measurement and analysis. Parameters ranging from point-temperature measurements to products of combustion are of scientific interest. Techniques employed in the infancy of microgravity investigations generally have been either intrusive to the system being tested or of an insufficient quantitative nature to be of optimal value to the investigator. Recent efforts have produced new nonintrusive techniques, but a sustained increase in science quality still depends on further improvements in measurement technology.

The goal of this project is to develop a series of more sophisticated measurement techniques applicable to the general area of microgravity combustion science. These techniques are intended to improve the accuracy and spatial/temporal yield of the data acquired and extend the range of applicability and access to the relevant parameters presently inaccessible through current methods.

Method

Four classes of measurement technologies are being investigated in an effort to improve the diagnostic techniques available to the microgravity combustion science community. Each of the four areas offers a different capability relative to the investigation of combustion science. Following is a brief synopsis of each operational principle, in association with the listing of the particular technique under investigation:

- **Two-Dimensional Temperature and Species Measurement**—A novel state-of-the-art, tunable solid-state pulsed laser source is used to conduct Rayleigh scattering and planar Laser-Induced Fluorescence (LIF) imaging. These techniques have already shown promise in terrestrial applications for providing temperature and species concentration measurements. Previously available lasers were too large and consumed too much power to be of practical use for space flight applications.

- **Exciplex Fluorescence for Droplet Diagnostics**—Fluorescent dopants, when added to a fuel and subsequently illuminated with pulsed ultraviolet laser light, provide the ability to determine liquid-phase temperatures and liquid/vapor concentrations of fuel droplets. Depending on the measurement conditions, fluorescence will be observed at differing wavelengths and intensities. These variations can, in turn, be related to fuel temperature and concentration changes via prior calibration.
- **Full-Field Infrared Emission Imaging**—A large proportion of flame emissions occur in the infrared IR range. This technique demonstrates the use of IR imaging arrays to detect and characterize flames and flame processes that would normally be inaccessible through the use of conventional arrays, which are sensitive in the visible spectrum.
- **Velocity Field Diagnostics**—Two velocity field diagnostic techniques developed for terrestrial applications are being adapted at the system level, with suitable configurations developed for use in ground-based microgravity research facilities (e.g., drop towers or reduced-gravity aircraft). These diagnostic methods are valuable in assessing heat- and mass-transfer rates during combustion. Specifically, this approach takes advantage of prior developments in the areas of laser Doppler velocimetry and particle image velocimetry (see fig. 7).

Schedule and Milestones

This advanced technology project had its origins in FY 1988, investigating microgravity fluids and combustion diagnostics. The combustion diagnostics project successfully competed for further ATD funding in 1992, in part because of prior successes in that area. New project funding ran through FY 1996. Listed below are accomplishments from the previous project:

- Detection of black-body emission of ceramic fibers in a gas jet (using a 2.2-sec drop tower).
- Observation of emissions from premixed hydrogen flames without chemical dopants.
- Demonstration of a color-based Schlieren technique to permit the quantitative determination of refractive index fields.

- Visualization of isolated gas-phase emissions from hot combustion products using imaging arrays in the near-IR region.
- Measurement of velocity field (IR-100 award for particle image velocimetry method).

The following are planned milestones for the four currently funded areas of study:

- Two-Dimensional Temperature and Species Measurement—Rayleigh and LIF flame-lab studies began in 1994, with low-gravity studies commencing in 1995.
- Exciplex Fluorescence Droplet Diagnostics—Laboratory tests were conducted throughout 1995, focusing on the extension to dopant/fuel systems with improved temperature ranges and sensitivity. Suitably identified low-gravity applications were conducted throughout 1996.
- Full-Field IR Emission Imaging—After reaching the initial goal of using the IR camera to acquire qualitative flame images, the accomplishment of long-range goals to quantitatively determine species concentrations and temperatures will occur throughout the course of this ATD.

- Velocity Field Diagnostics—Laboratory work on simple flames took place in 1994, and low-gravity flame testing was conducted in 1996.

Application and Technology Transfer

In general, all of the techniques will use simple laboratory and low-gravity facility combustion experiments for developmental testing. While the majority of the measurement requirements are common throughout the microgravity combustion discipline, applications that will directly benefit from these developments include low-gravity aircraft investigations of solid-surface combustion and premixed-gas combustion experiments, and drop tower studies of gas-jet diffusion flames, droplet combustion, and liquid-pool fires.

Researcher and Development Center

Mr. Paul Greenberg
 NASA LeRC
 Mail Stop 110-3
 21000 Brookpark Road
 Cleveland, OH 44135

Phone: (216) 433-3621
 E-mail: paulg@strangeness.lerc.nasa.gov

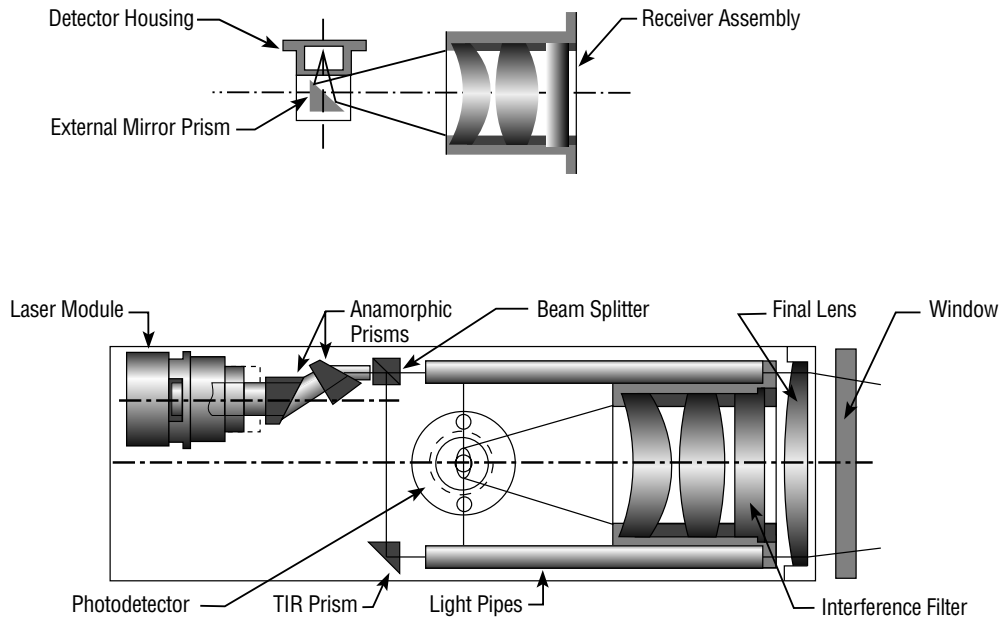

FIGURE 7.—Compact solid-state coaxial backscatter laser Doppler velocimetry.

High-Resolution Pressure Transducer and Controller

Objectives

The objective of this effort is to develop high-resolution pressure transducers and controllers that perform better than those currently available commercially. Following development of the proposed capabilities, these devices can be used to support ground-based and flight investigations in the MSAD fundamental physics program.

Three types of devices will be developed and evaluated under this task. The first device is a pressure transducer (fig. 8) using a capacitive readout system that will be capable of measuring pressures in the 10-bar range, with a resolution of 1 part in 109 at helium (He) temperatures. Since it can be used at any temperature, this device will have a wide range of applications and will be tested for performance at 300 K, 77 K, and 4 K. The second device is a more sophisticated transducer (fig. 9) that takes advantage of recent advancements in superconducting technology at Stanford University. This device will be able to read pressures in the 10-bar range to about 1 part in 1,011. The third device will be a pressure controller based on similar technology, which also operates in the 10-bar range and is capable of stabilizing the pressure to about 1 part in 1,010 over a limited pressure swing.

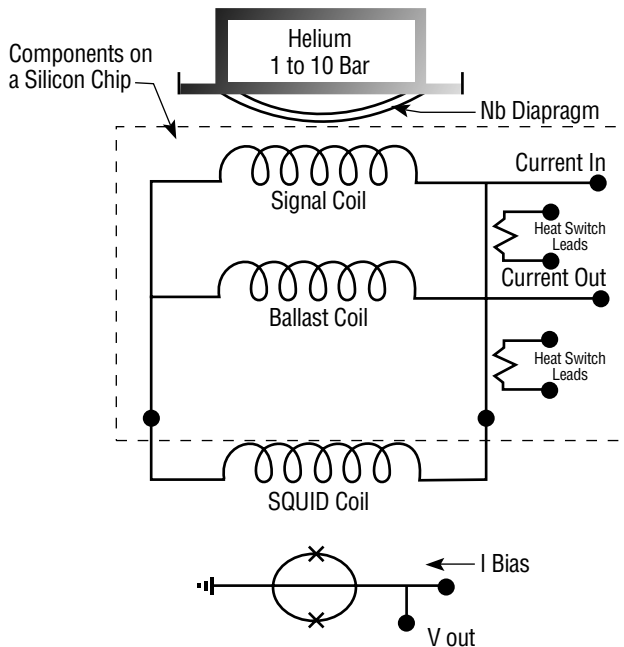

FIGURE 8.—Superconducting pressure transducer.

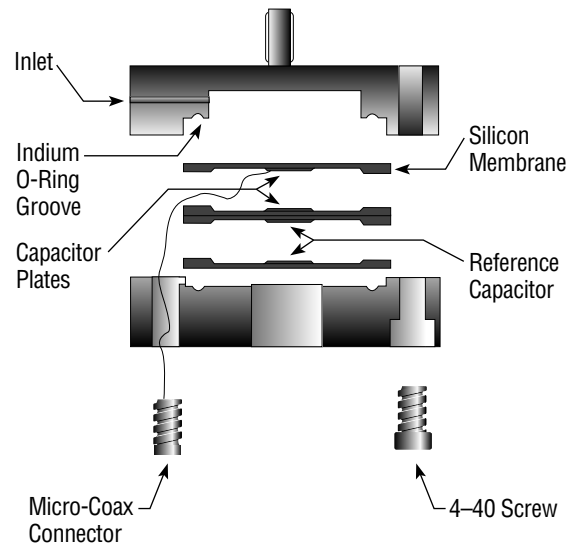

FIGURE 9.—Capacitive pressure transducer.

Method

Both transducers will employ a diaphragm attached with a leak-tight seal to a helium chamber. The diaphragm will bend when the pressure of the helium in the sample chamber changes. The first device will detect the location of the midpoint of the diaphragm capacitively. All components of the capacitive transducer will be manufactured from silicon using micromachining techniques, and its design will incorporate an in situ reference capacitor to minimize the influence on resolution by leads to the room temperature bridge circuit.

The superconducting transducer will use the location of the niobium diaphragm to modulate the inductance of a superconducting thin film coil patterned on a silicon plate just below the diaphragm. The inductance changes are read out with very high precision by a SQUID, which is located next to the transducer. Capacitive or inductive means will be devised to apply force to the diaphragm in order to control the pressure with high resolution. Electrostriction and magnetostriction methods are also under consideration for this purpose. The merit of all methods will be evaluated before a design is chosen.

Schedule and Milestones

This project began in FY 1994. A capacitive transducer demonstrating a resolution of better than 1 part in 107 has

been constructed and tested. Currently, the design is being optimized to reach the required resolution. Final performance testing of the improved design will be completed in FY 1996. A prototype superconductive transducer has been developed, and its performance has been measured at low pressures.

A noise factor of 2×10^{-10} bar/ $\sqrt{\text{Hz}}$ at frequencies from 0.1 to 1.0 Hz was measured, indicating that the target resolution should be achieved at a pressure of 20 bar. At frequencies below 0.1 Hz, the performance was reduced due to microflux jumps and poor temperature stability in the test probe.

The cause of microflux jumps is under investigation. At frequencies above 1.0 Hz, the device performance was reduced by mechanical vibrations in the test setup. Measurements with a capacitive forcing plate indicate that the device is able to control pressure to about 10^{-10} bar with a 0.1 Vdc signal applied to the plate. An improved design, primarily addressing the microflux jump problem, is under construction. It was tested by the end of FY 1996. The results of this ATD will be shared with colleagues through professional publications and at conferences.

Application and Technology Transfer

The study of cooperative phase transitions has long been an area of active investigation in condensed-matter physics. Recently, the Lambda Point Experiment had a highly successful flight aboard the space shuttle *Columbia* as part

of the first United States Microgravity Payload (USMP-1) mission. This pioneering flight, coupled with strong response in the area of low-temperature microgravity physics to recent NRA's, has clearly demonstrated the benefits to be gained from a vigorous fundamental physics program. Currently, researchers can only control and measure one thermodynamic variable, temperature, to better than 1 part in 10⁹. This nanokelvin High-Resolution Thermometry (HRT) is based on superconductivity and high-performance temperature regulation technology. A combination of HRT's and high-resolution pressure detection and control would be a powerful tool for MSAD researchers performing low-temperature microgravity physics experiments and ground-based investigations, with the potential to lead to flight experiments. A recently selected flight-definition investigation measuring the universality of the lambda transition over a large pressure range relies on the results from this ATD. This experiment is one of the candidates for the first flight of the Low-Temperature Microgravity Physics (LTMP) facility on the *ISS* in 2003.

Researcher and Development Center

Dr. Ulf Israelsson
NASA JPL
Mail Stop 79-3
4800 Oak Grove Drive
Pasadena, CA 91109-8099

Phone: (818) 354-9255
E-mail: Ulf.E.Israelsson@jpl.nasa.gov

Free-Float Trajectory Management

Objectives

Many researchers perform experiments that are sensitive to the effects of gravity aboard aircraft flying low-gravity (low-g) trajectories. The aircraft, flown in ballistic trajectories (see fig. 10), attain periods of freefall that provide the desired low-g environment. These trajectories are characterized by an initial trajectory entry phase, which can be very dynamic, followed by the stabilized low-g period, and, finally, an exit phase. Ideally, the entry phase should be minimized to allow the longest possible duration of low-g.

The low-g environment experienced by an experiment attached to an airplane is degraded by many disturbances, including vibrations from the aircraft, acoustic vibrations, airflow, and self induced disturbances. However, an experiment package allowed to free-float during the stabilized low-g phase will only be affected by direct disturbances. The drawback of free-floating an experiment is that the package typically contacts the walls of the aircraft after only a few seconds, due to the initial velocity of the package at release and the rotation of the aircraft during the parabolic trajectory. Longer free-float times are achievable, but are not predictably reproducible.

The objective of this work is to develop the technology for an extended, consistently reproducible acceleration environment during the stabilized low-g phase of the trajectory, specifically for free-float packages. The goals are to extend the free-float time to 10 sec or longer and to obtain stable accelerations of 0.001 g or lower in a consistent, reproducible manner.

Method

Improving the low-g environment for free-float packages requires optimal control of the aircraft trajectory and the release of the package. The control of the trajectory is dependent on the limitations of the specific aircraft used and the feedback used by the pilots to maneuver through the trajectory. Defining the trajectory in terms of air speed and pitch angle upon entry, acceleration level during pull-up, and air speed and pitch angle upon exit of the trajectory is the first step in maximizing the overall trajectory time and particularly the duration of stable low gravity.

To control the aircraft maneuver during the low-g phase, specific commands for pitch, roll, and throttle must be provided to the pilots. This requires the development of a control law to generate the appropriate commands. The control law is based on the states of the aircraft dynamics and the position of the experiment package in the aircraft cabin.

Once the stable low-g environment has been established, the controlled release of the experiment package will provide a consistent means of initializing the free-float period. By optimizing the initial release velocity, the package will rise off the aircraft floor and the controller will monitor its location in the aircraft. The control law will develop the appropriate control commands for the pilots to fly the aircraft about the trajectory of the free-floating package. The control commands will be displayed graphically to the pilots.

The test-bed for the developed technology will be the NASA LeRC DC-9 aircraft.

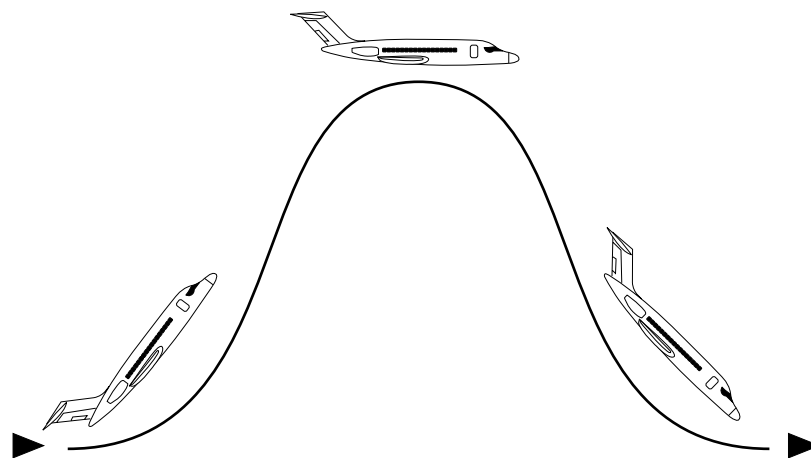

FIGURE 10.—Flight trajectory of the DC-9 reduced-gravity aircraft.

Schedule and Milestones

This ATD project was initiated in FY 1995, and is planned to continue through FY 1997. In FY 1996, initial flight testing was performed to obtain baseline data on the current performance of the DC-9 and the quality of its trajectories. Typically, free-float trajectories have acceleration levels of <0.001 g and last approximately 4 sec. Out of over 350 trajectories, only three lasted 10 to 11 sec.

A rack-release system was developed to push the rack off the aircraft cabin floor once a stable low-g environment is attained. The rack is held in place by electromagnets during the pull-up portion of the trajectory. Once stable low-g is attained, the electromagnets are turned off, and the rack is pushed away by four small pneumatic cylinders. Flight testing of this system was performed in summer 1996.

A three-dimensional positioning system for tracking the location of the rack during free-float has been procured. The system uses blinking infrared light emitting diodes (LED), which are tracked by a set of cameras. The location of the rack is calculated in real time and transferred to the control computer. This information will be used in the implementation of the trajectory guidance system. Flight testing of the position-tracking system was performed in late summer 1996.

Instrumentation of the DC-9 aircraft to measure aircraft control surface positions and pilot input continues whenever the aircraft is available. Testing of the instrumentation and aircraft parameter-identification flight testing are scheduled for late summer 1996.

Application and Technology Transfer

Numerous researchers utilize low-g aircraft trajectories to perform scientific investigations in the fields of combustion science, fluid physics, and materials processing. For some, an extended high-quality low-g free-float environment, the goal of this ATD, would be sufficient for most or all of their testing needs and would eliminate the need for more expensive and time-consuming suborbital or orbital carriers. Although the developed system will only be applicable to a specific aircraft (in this case, the NASA LeRC DC-9), the technology to develop the system will be applicable to other aircraft.

Researcher and Development Center

Kirk Logsdon
NASA LeRC
Space Experiments Division
Mail Stop 500-115
21000 Brookpark Road
Cleveland, OH 44135

Phone: (216) 433-2836
E-mail: kirk.logsdon@lerc.nasa.gov

Passive Free-Vortex, Two-Phase Separator

Objectives

Effective low-power two-phase separation systems are vital for the cost-effective study and utilization of two-phase flow systems and the investigation of the governing physics of two-phase fluid flows. The fluid physics community has shown a keen interest in microgravity gas-liquid flows for a number of years, since the study of microgravity flows has the potential to reveal significant insight into the controlling mechanisms for the behavior of flows in both normal and reduced-gravity environments. Two-phase fluid mixtures in microgravity generally use a mechanical separation device to mimic a process that occurs naturally in terrestrial environments. Commercial separator technology is not directly applicable to the requirements of spaceflight hardware because of weight, power consumption, vibration, design complexity, reliability, and volume constraints. Terrestrial passive-separator technology is not valid, since such devices utilize gravity to accumulate the phases after separation.

Long-duration experiments aboard either the space shuttle or the *ISS* will require that consumable fluids be recycled for continuous use. The experiments require that the component fluids (gas and liquid) be separated into single-phase states prior to reuse in the experiment hardware. Once the fluids have been successfully separated, they may be reutilized for subsequent investigations.

The objectives of the work leading to the development of the Passive Free-Vortex Separator (FVS) (see fig. 11) follow:

- Design, construct, and test a vortex separator with the capability of continuous closed-loop operation, liquid extraction, and recycling capabilities, and the ability to recycle air with humidity levels that can be reasonably handled with dessicant beds (<60 percent) for continuous gas recycling.
- Design, construct, and test a liquid drainage system based on the vortex separator, with an absence of gas bubble entrainment in the effluent bulk liquid.
- Design, construct, and test a vortex separator that yields a wider range of system operations and/or decreased liquid carryover and which will be suitable for intermittent operation aboard reduced-gravity aircraft.

- Use experimental data to develop and verify analytical models that will be used as design tools.

Method

The baseline FVS was developed to perform in an intermittent microgravity environment for a short duration (20 sec) aboard reduced-gravity aircraft. This device has operated successfully during a number of operational tests with Two-Phase Flow Experiment rigs. The operation of the baseline FVS has been studied through high-speed video and improvements have been incorporated into the system. Flight tests aboard the NASA LeRC DC-9 reduced-gravity aircraft have shown that the liquid carryover from the separator has been eliminated and that the system is now suitable for intermittent operation aboard reduced-gravity aircraft. The tests were conducted as a part of an ongoing scientific investigation to show that the device could operate successfully over a typical range of gas and liquid flowrates.

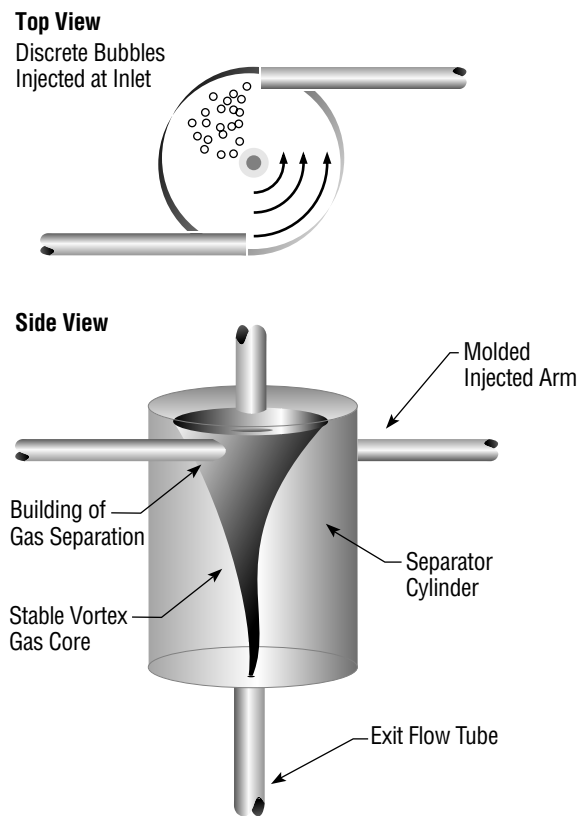

FIGURE 11.—Top and side views of the Passive Free-Vortex Separator.

A ground-based test section has been completed and tests (including flow visualization) have been conducted to observe the structure and stability of the vortex core. For these tests, particles or gas bubbles are injected into the liquid flow and their trajectories are observed. These studies have demonstrated an ability to develop a gas core and a liquid rotating vortex, which could be utilized for gas and liquid extraction in both vertical and horizontal orientations (horizontal being most similar to microgravity). A test section is now being developed for testing aboard the DC-9 aircraft to validate these design concepts in microgravity operation. An additional test-bed is under development for screening of liquid extraction concepts.

Limited analytical model development and verification to develop physical understanding of the fluid dynamics of the vortical flows and to ultimately develop design aids are under way. Single-bubble models have been developed for both inviscid and quasiviscous flows. A test section has been designed and is in fabrication for use in validating the single- and multi-bubble models.

Schedule and Milestones

The Passive Free-Vortex Separator Project began in FY 1996 and was defined as a three-year effort. Development of the ground-test sections will be completed in FY 1996, with testing to continue into FY 1997. The liquid extraction system will be completed in FY 1997. The continuous recycle separator design and testing will be initiated in FY 1997 and completed in FY 1998. Intermediate testing of designs to date will continue throughout this period as the aircraft is available.

Application and Technology Transfer

In addition to the traditional microgravity testing and spaceflight applications for technology transfer, potential applications have been identified in the medical science community for separating blood and gases. The lack of moving parts in the FVS is important to such applications because possible tissue damage caused by dynamic separators would be reduced.

Environmental control systems, life-support systems, waste fluid handling, and fluid management in cryogenic tanks are also potential applications for the FVS device. Currently, the device is being utilized by two microgravity test rigs at LeRC, and a derivative calibrated device has been used by investigators to quantify the liquid portion of two-phase flow in experiments.

Researcher and Development Center

John McQuillen
NASA LeRC
Mail Stop 500-102
21000 Brookpark Road
Cleveland, OH 44135

Phone: (216) 433-2876
E-mail: jmcquil@popserve.lerc.nasa.gov

Additional information about this project also may be obtained from:

Michael Shoemaker
ADF Corporation
2001 Aerospace Parkway
Brookpark, OH 44142

Phone: (216) 977-1137
E-mail: fsshoe@chester.lerc.nasa.gov

Surface Fluctuation Spectrometers for Characterization of Fluid and Crystal Surfaces

Objectives

Surface light scattering is an optical technique used to probe fluid inter-faces. These interfaces are either liquid-liquid or liquid-vapor, and they may include a monolayer. Surface light scattering spectrometers provide a noninvasive way to obtain surface tension and viscosity data, as well as noncontact temperature and surface tension gradient measurements at the fluid interface. This work will extend this application to measure displacements of solid surfaces, such as those encountered in crystal growth.

The surface light scattering instrument builds upon earlier NASA work that provided a miniature modular version of traditional laser light scattering equipment. Project goals are as follows:

- To construct a surface light scattering instrument using fiber-optics-based technology.
- To develop and test cross-correlation, a novel data acquisition scheme. This will allow automatic correction for bulk fluid sloshing, without using special optical trains.
- To develop a laser interferometer for measuring the rate of crystal growth. The interferometer is expected to measure displacements ranging from $<6 \text{ \AA}$ to greater than a meter.

Method

The surface light scattering instrument (see fig. 12) is being developed in a building-block fashion. Comparisons with less advanced bulk optics and fiber optics units are being made during the program to quantify the success of the design efforts. Test-bed surface light scattering units are being developed to conduct ground-based technology trials.

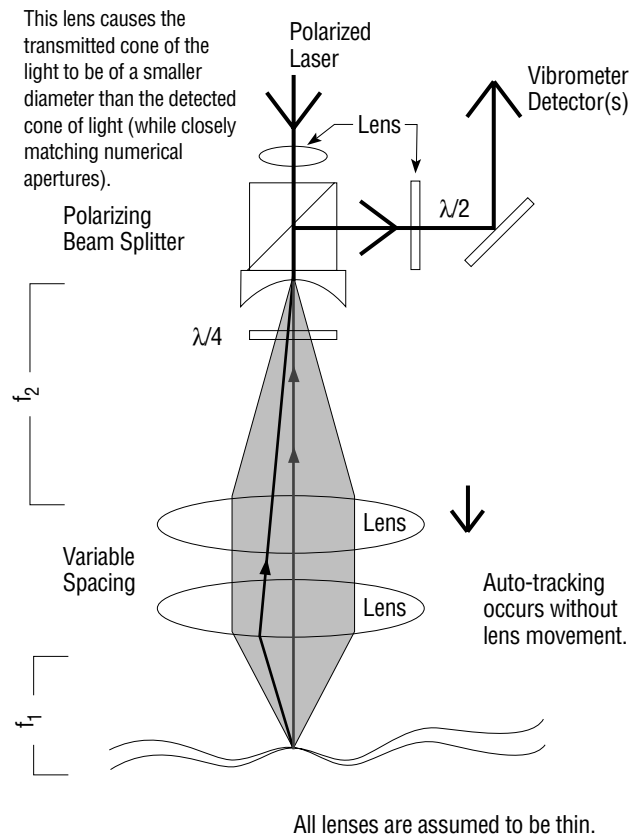

FIGURE 12.—The Interferometric Laser Vibrometer with autotracking optics. A cone of light is projected onto the fluid surface. All light paths from the surface to the detector have the same transit time. Two examples of return paths are shown. These lines are actually the center lines of returning cones of light (to avoid clutter, only one returning cone of light is shown).

The cross-correlation work is being performed in the following well-defined steps:

- Cross-correlate two first-order grating spots. The construction of the next-generation instrument has begun with building a version of the existing instrument, which has two fiber optics signal receivers.

- Cross-correlate two symmetrically scattered signals using a fiber-optics coupler to generate the reference signal.
- Cross-correlate two sets of symmetrically scattered signals using diffractive optical elements (DOE). The team proposes to develop, build, and test a new generation of surface light scattering spectrometers on a single chip that has the full dynamic capability of measuring the physical surface parameters, like its cat's-eye-optics predecessors, but that has the added capability of looking at surfaces which are neither transparent nor reflective.
- Build a multipoint-array surface light scattering spectrometer.

This will be accomplished by combining several of the above instruments with computer algorithms that will be developed for this project.

A fiber-optic interferometer will be built to demonstrate the feasibility of measuring crystal growth rate with a complete fiber-optic technique. This instrument will be capable of self-alignment and flare rejection, and will use the polarization states of incoming and reflected beams. Polarization maintaining fiber-optic couplers for heterodyning will be used. This will be combined with a fiber length adjustment technique, laser diodes, and solid-state detectors to provide accurate fringe counts, which are a measure of interface velocity and displacement direction. To this will be added a new and simple technique for measuring the direction of displacement.

Schedule and Milestones

This project began in FY 1996. Construction of both a fiber-optic version of the interferometer and the cross-correlation surface light scattering spectrometer will be completed in FY 1997. Instrument testing will continue throughout the project. The Surface Fluctuation Spectrometer development builds upon the work initiated by the Laser Light Scattering ATD project (FY 1988–93) and the Surface Light Scattering ATD project (FY 1992–95).

Application and Technology Transfer

Surface tension dominates many chemical processes and everyday phenomena, and acts to maintain the smallest possible surface area. Surface tension affects cooking, cosmetics, tertiary oil recovery, detergents, controlled-release and targeted drug delivery, materials processing, and many other activities. The study of surface tension-driven phenomena is often complicated by the masking effects of gravitational forces. These forces are not present in the reduced-gravity environment of an orbiting space station or space shuttle. The instrument produced under this ATD provides a noninvasive measurement of surface tension, from which surface temperature and viscosity information can be extracted. Viscosity, the internal friction of a fluid, is important for various substances, such as the liquid crystal displays used in flat-screen computer monitors.

Space experiments that could benefit from surface light scattering include critical-point studies, free-surface phenomena experiments, pool-boiling experiments, surface tension-induced instabilities experiments, surface tension-driven convection experiments, and crystal-growth experiments. The interferometry part of this instrument can measure crystal growth rates of about 10 nm/hr, as well as high amplitudes (~700 microns) for fluid power spectra, allowing empirical study of nonlinear phenomena such as turbulence and chaos.

Researcher and Development Center

Mr. William Meyer
 NASA LeRC
 Mail Stop 105-1
 21000 Brookpark Road
 Cleveland, OH 44135-3191

Phone: (216) 433-5011
 E-mail: bill@sarah.lerc.nasa.gov

The Laser Feedback Interferometer: A New, Robust, and Versatile Tool for the Measurement of Fluid Physics Phenomena

Objectives

The objectives of this ATD are to evaluate, adapt, and deliver a novel form of interferometry, based on laser feedback techniques, which will provide a robust and versatile state-of-the-art diagnostic instrument applicable to a wide variety of microgravity fluid physics and transport phenomena. Laser feedback interferometry (LFI) differs from conventional interferometry in that it uses the laser as both a light source and a phase detector. Either a cavity or a semiconductor (diode) laser can be used. LFI can be used either in direct reflection or by passing the interrogating beam through the sample and then reflecting it into the laser.

The instrument developed under this ATD is capable of measuring both temporal and spatial changes in optical path length and object reflectivity. Phenomena that vary slowly over time and dynamic phenomena can be measured over both microscopic and macroscopic fields of view. Since the interferometer can be used to integrate interference fringes, there is no upper limit to the range of the measured displacement. Additionally, the direction of displacement can be determined unambiguously. The apparatus will accommodate small and large working distances (up to many centimeters). For a microscopic field of view, the laser feedback interferometer has been both incorporated with an optical microscope and combined with long working distance objectives.

Method

This ATD consists of a multiyear effort to accomplish three specific goals:

- (1) Build an interferometer based upon a continuous wave helium/neon (HeNe) laser with stationary imaging optics and a translated sample, quantifying the random and systematic measurement errors (including sensitivity to external perturbations) and calibrating the technique by:

- Measuring the cantilever bending of a piezoelectric bimorph.
- Measuring the static contact angle for a Newtonian fluid.

- (2) Modify the two-dimensional scanning technique so that the sample remains stationary and the optics translate.
- (3) Investigate the LFI response with semiconductor diode lasers and incorporate diode laser into previously designed instrument.

To ensure that the apparatus meets the science requirements of the diverse microgravity research community whenever possible, other fluid researchers will be encouraged to participate in the various phases of this project and to utilize the technology.

Schedule and Milestones

This ATD project began in FY 1995. LFI has been combined with the principles of phase-shifting interferometry to produce a new instrument that can simultaneously measure the variation in optical path length and discern sample reflectivity variations. The accuracy and precision of the technique has been determined by measuring the cantilever bending of a piezoelectric bimorph, the phase change in an electro-optic modulator, and the contour of static drops of oil on coated substrates. In addition, the response of the instrument for high- and low-reflectivity samples has been characterized. The ability of the instrument to measure bending and vibrational displacements (in a noisy environment with minimal vibration isolation) was demonstrated at the NASA Technology 2005 conference held October 1995.

Figure 13 depicts the variations in the optical path length, and figure 14 depicts the variations in the reflectivity for a drop of silicone oil on a single-crystal silicon wafer, which was coated to prevent the drop from completely wetting the silicon. The images show a 30-micron by 30-micron scan of the 26 micron-diameter drop. The measured contact angle of 68° agrees with the value cited in the literature.

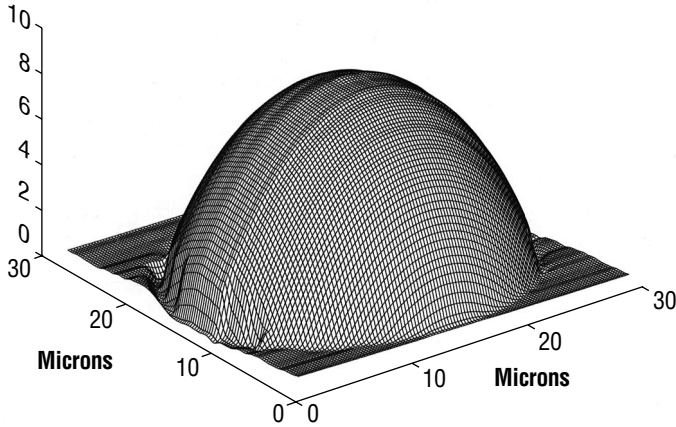

FIGURE 13.—Optical path length variation across a silicone oil drop on a coated single crystal silicon wafer.

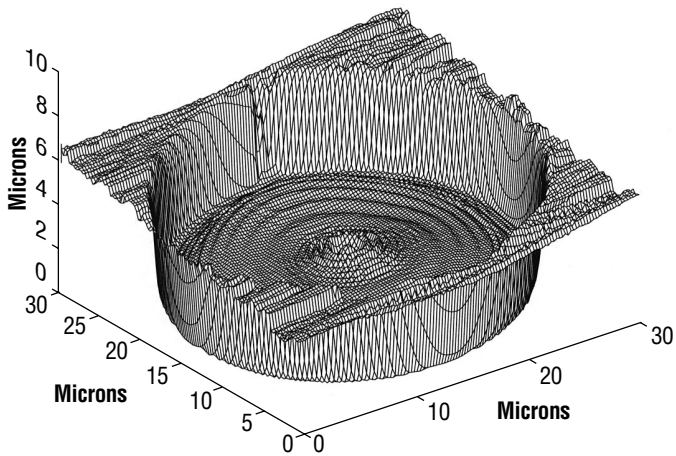

FIGURE 14.—Variation of the reflectivity (fringe visibility) across a silicone oil drop on a coated single-crystal silicon wafer.

These variations can arise either from changes in the index of refraction along the path of the ray (a function of temperature, pressure, mass density, and concentration) or from changes in the distance a ray travels.

Some examples of science requirements of experiments in the fluid physics and transport dynamics discipline that can be determined from accurate measurements of the change in optical path length include determination of the location and orientation of the contact line and interface shape between two fluids, the evolution of the thickness of a thin film, deformation of a free surface due to evaporation or vibration, resonant mode shapes in bubbles, fundamental fluid parameters such as surface tension and viscosity, variations in temperature and density in a fluid, diffusion coefficients, and fluid velocity. Examples can also be found in the other MSAD disciplines.

The developed technology is also likely to be attractive to many users outside the aerospace community. In fact, LFI will expand the applicability of interferometry to nearly every scientific discipline, including biomedical engineering, chemistry, materials science, mechanical engineering, and physics.

Researcher and Development Center

Dr. Ben Ovrin
 NASA LeRC
 21000 Brookpark Rd.
 Cleveland, OH 44135

Phone: (216) 433-8335
 E-mail: ovryn@wave.lerc.nasa.gov

Application and Technology Transfer

Often the primary science requirements of experiments of relevance to the MSAD, both ground- and flight-based, involve the evaluation of phenomena by measuring spatial variations of the path length of an interrogating light ray.

Crystal Growth Instrumentation Development: A Protein Crystal Growth Studies Cell

Objectives

Current microgravity PCG hardware systems are hybrid, attempting to serve two purposes: acquire data about the processes of crystallization and grow crystals suitable for x-ray diffraction studies. The hardware relies on a “one-shot” design, with all solution parameters defined prior to launch and a return to Earth between experiments. This leads to compromises in system design, with the result that neither purpose is successfully served. While structural studies of protein crystals require the best nucleation and growth conditions for each crystal growth cell and the return of the crystals to Earth for analysis, the study of the growth process requires that every solution parameter be rigorously controlled and measurable for maximum data collection.

The primary goal of this project is to design and construct prototype cells and associated systems for the study of the PCG process. A single-cell design will be developed that is suitable for studying solution concentration gradients surrounding a growing crystal, local interfacial features of protein crystals under growth and etching conditions, and simple averaged face growth-rate measurements. The system will be capable of making all measurements under either quiescent or flowing solution conditions. A second goal of the proposed work is to develop practical methods for storing proteins prior to use in crystal growth (and other) experiments. The following characteristics are desired for a PCG Analysis Chamber system for microgravity growth studies:

- Growth cells suitable for specific study goals.
- Temperature control of the growth cell from 0–40 °C (± 0.05 °).
- Control of nucleation and growth of crystals at a defined location, or ease of centering a specific crystal within the observation region.
- A fluidic system (see fig. 15) that accurately prepares crystal growth solutions from stock solutions and delivers them to the growth cell.
- Cells accessible for additions to and/or modifications of the solution.

- The ability to do follow-up experiments based upon preceding growth results.
- Some cell adjustment to bring selected crystal faces in line (perpendicular or parallel) with the optical axes.
- Easy accessibility to other solution measurement systems (pH, conductivity, etc.) for maximum data return.
- Capability of being remotely operated from the ground to the maximum extent possible.
- Ability to maintain proteins in a viable state prior to use.

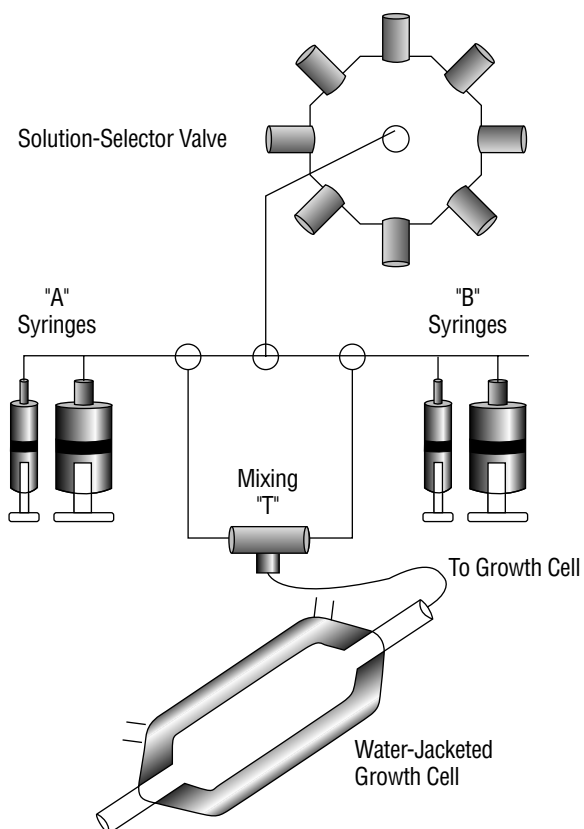

FIGURE 15.—In the fluidic system, each valve port is used to prepare one-half of the crystal growth solution. The final solution is freshly mixed just prior to injection into the growth cell. More solution components, or a larger number of proteins, can be accommodated by the addition of more eight-port solution-selector valves.

Method

An initial cell design was found to have too many design flaws for facile use. Flaws included the problems of how to replace the solution within the cell without introducing bubbles and how to design optical systems to pass through a curved glass interface. A two-cell approach was then tried, with one cell optimized for holographic data collection and the other for interferometric data collection. However, as the ground-based data analysis methods are most likely to employ interferometry, the limiting resolution in this case would have come from the holograms collected by the cell. Accordingly, a single-cell design approach, optimized for interferometric data collection methods, has now been implemented. Several growth cells have been fabricated and are being tested, the largest having a rectangular cross section of 2.0 cm×1.0 cm×0.1 cm. The very small fluid volume also reduces the amount of solution needed for a given experiment. This cell is currently being tested for its suitability in PCG experiments with an existing crystal growth-rate measurement system in this laboratory.

The target thermal regulation for the initial design was 0.1 °C. A thermal regulation system using resistance heaters to actively regulate a growth cell to within 0.015 °C has been devised. Operation at ambient +5 °C or lower (down to 0 °C) requires active cooling. This has led us to investigate the use of a circulating fluid bath, rather than actively heating and cooling the cell.

This arrangement is beneficial because the waste heat from the peltier cooling elements can be dumped well away from the growth cell and associated optics. Water-jacketed growth cells have been obtained and will be tested in an interferometer system.

A fluidic system, illustrated in figure 15, is now under construction. This system will be able to prepare both protein and precipitant solutions. The upcoming year will see the completion of the fluidic system, which will then be connected to a growth cell in an interferometry system and used for routine growth solution preparation. The ability to store solutions, particularly protein solutions, so that they can be used over a period of several months is of primary importance. Storage stability experiments with model proteins to determine optimal conditions are being conducted. So far, the proteins lysozyme and ovostatin have been stored as a solution and as freeze-dried powder at 20, 4, and -20 °C, and tested biweekly for crystallizability. While storage in the frozen or freeze-dried states is preferred on

Earth, it will present problems with solution remixing in a microgravity environment. These tests will be repeated several times with these and other proteins. Currently, storage as a solution at 4 °C appears to be satisfactory.

Schedule and Milestones

This project started in FY 1995, and the work is a follow-up of a previous 1-yr proof-of-concept effort demonstrating the close thermal regulation of a small fluid-volume PCG cell. Growth cell development efforts for the upcoming year will be directed toward combining a fluids preparation system with a growth cell in a working interferometry system and toward performing initial trials to determine the suitability of the assembled system for collecting PCG data on Earth. The effort in 1997 will also include continued testing of methods for the long-term protein storage and preliminary designs of storage cells that are suitable for interface with a robotics system.

Application and Technology Transfer

Using this PCG cell, researchers will be able to monitor and change selected solution parameters to optimize experiment conditions and return of data. This will enable more rigorous study of microgravity effects on the PCG process. Long-term protein solution storage and stability will become a concern as the timescale of microgravity experiments increases. Developing methods for long-term protein storage will improve both this and future microgravity-based instrumentation.

Researcher and Development Center

Dr. Marc Pusey
NASA MSFC
Mail Code ES76
Marshall Space Flight Center, AL 35812

Phone: (205) 544-7823
E-mail: Marc.Pusey@msfc.nasa.gov

High-Resolution Thermometry and Improved SQUID Readout

Objectives

One very active area of research in condensed-matter physics is the study of critical phenomena and phase transitions. The success of critical-point experiments depends on both measuring and controlling the thermodynamic state of the test sample with very high precision. Particularly in the microgravity environment, the precision with which temperature and/or pressure can be measured often sets the limit for science return.

The current state-of-the-art HRT's use paramagnetic salts to sense temperature and SQUID's to read out the signal. These thermometers have relatively large heat capacity and usually cannot be in direct thermal contact with a test sample. As a result, their performance can be degraded by thermal fluctuations and, in the space environment, by particle radiation. The goal of this project is to develop a high-resolution penetration depth thermometer

(PDT) using a Two-Stage Series Array SQUID Amplifier (TSSA), which overcomes these problems, for readout. The PDT uses a thin superconducting film (see fig. 16) as the active element and can have very low mass and heat capacity. In contrast to HRT's, a PDT can be made in a variety of geometries, allowing greater flexibility in experiment design and better thermal coupling. The TSSA uses an array of up to 200 SQUID's as an amplifier for a single-input SQUID. This arrangement simplifies the room-temperature electronics required and leads to better energy resolution by an order of magnitude. The TSSA is also designed to be relatively insensitive to external magnetic fields and electromagnetic interference (EMI). These features make it very attractive for spaceflight applications by reducing both cost and shielding requirements.

Using a TSSA for readout, the ultimate sensitivity of a PDT is 10^{-11} K/ $\sqrt{\text{Hz}}$. This figure is roughly independent of the thickness and type of superconductor used. Since a large number of microgravity experiments probing the superfluid transition in liquid He are being planned, the goal of this project is to demonstrate 10^{-10} K/ $\sqrt{\text{Hz}}$ resolution near the lambda point of He (2.17 K).

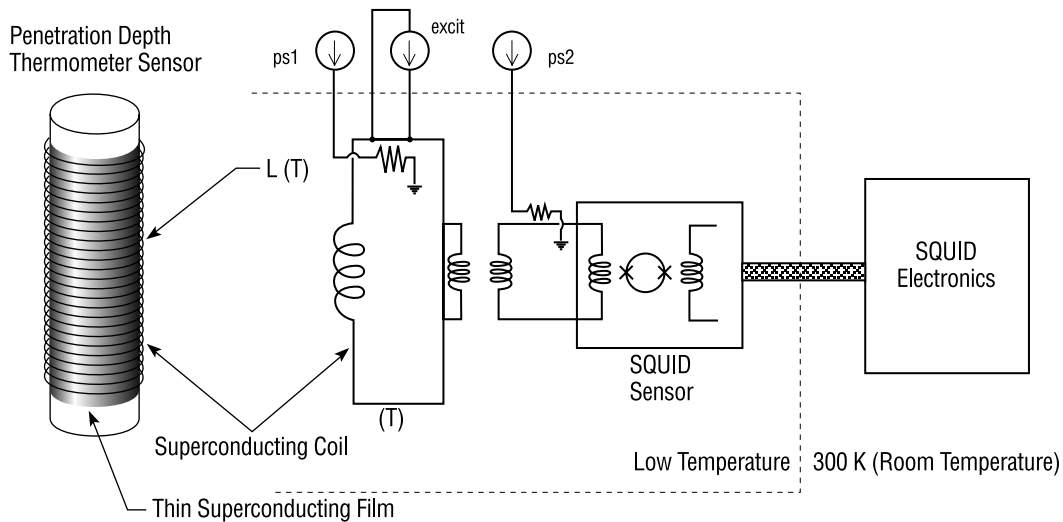

FIGURE 16.— Circuit for excitation and readout of penetration depth thermometer sensors. I_{excit} and $I_{\text{ps1,2}}$ are the excitation and persistent switch heater currents.

Method

One defining property of superconductors is their ability to prevent the penetration of external magnetic fields into their interior. In a superconducting film thinner than the London penetration depth, the effect leads to only a partial attenuation of external fields. Because attenuation varies with temperature, a coil located near a superconducting film will exhibit a temperature-dependent inductance. The coil is connected in series with a SQUID amplifier to read out changes in inductance and, hence, temperature. Resolution is determined by a number of factors, including coil configuration, film geometry and thickness, substrate material, and SQUID current resolution. Aluminum films will be used for this work, since the transition temperature can be varied by adjusting film thickness. This will facilitate developing a PDT with maximum sensitivity at 2.17 K. Other parameters will also be varied to obtain optimum performance.

Development of the TSSA will focus on eliminating extrinsic noise inputs and breadboarding feedback-control electronics that are needed to linearize the output and increase the dynamic range. These electronics may be able to incorporate 1/f noise-reduction techniques used in commercial systems. They will be tested for sensitivity to EMI. The goal is to produce a flight-qualifiable SQUID system with better energy resolution than existing commercial systems by at least a factor of 2 at frequencies down to 1 Hz, improving to a factor of 10 better above 500 Hz.

Schedule and Milestones

This project was initiated in FY 1994. Following are the most significant milestones to date and through its completion:

- Intrinsic sensitivity in a PDT sensor of 10^{-9} K/ $\sqrt{\text{Hz}}$ has been demonstrated.
- Sensors that have greatest sensitivity near the lambda point of helium (2.17 K) have been fabricated and are projected, based on preliminary measurements, to have intrinsic sensitivities of 3×10^{-10} K/ $\sqrt{\text{Hz}}$. This can be improved to 2×10^{-10} K/ $\sqrt{\text{Hz}}$ using the TSSA for readout.
- Fabrication of a thermally stable platform is nearly complete. Tests to demonstrate 10^{-9} K/ $\sqrt{\text{Hz}}$ temperature resolution in a PDT sensor near 2.17 K will be completed in FY 1996.

- The energy resolution of TSSA chips of <500 Hz has been demonstrated at frequencies above 300 Hz ($h=6.6 \times 10^{-34}$ J/Hz (Planck's constant)), the fundamental physical limit of resolution for any measurement device). This corresponds to 2 pA/ $\sqrt{\text{Hz}}$ resolution of input current. The devices exhibit 1/f noise below about 10 Hz.
- A wide dynamic range (>106), direct-coupled feedback controller has been developed for the TSSA, with a bandwidth in excess of 10 kHz. The controller adds negligibly to the total noise, so that closed-loop and open-loop performance is identical.
- EMI and electromagnetic contamination (EMC) sensitivity tests will be performed by the end of FY 1996.

Application and Technology Transfer

These technologies are being developed to aid a growing number of flight experiments in microgravity that use high-resolution thermometers, high-resolution pressure sensors, and SQUID's for sensor readout. The PDT can be used both as a thermometer and as a fast-response thermal detector, with such applications as the detection of second sound waves in superfluid helium. The TSSA can be used in any application requiring SQUID's, but is best suited to measuring signals at medium to high frequency, where its sensitivity exceeds that of commercial SQUID systems. In applications where measurement resolution is not limited by SQUID noise, the TSSA can be implemented at considerably lower cost than commercial systems due to its simplified control electronics. It is also useful for ground-based applications such as magnetic resonance imaging and magnetometers for research in the fields of biology, chemistry, geology, and physics.

TSSA chips are commercially available from HYPRES, Inc., Elmsford, NY 10523.

Researcher and Development Center

Dr. Peter Shirron
Code 713 GSFC
Greenbelt, MD 20771

Phone: (301) 286-7327
E-mail: Peter.Shirron@gssc.nasa.gov

Determination of Soot Volume Fraction Using Laser-Induced Incandescence

Objectives

Quantitative data obtained by advanced diagnostics often are needed to test detailed predictions in numerical models and to provide new knowledge of microgravity combustion science. In response to this need for advanced diagnostics, and with recognition of the constraints of a microgravity environment, LII is being developed as a two-dimensional imaging diagnostic for the measurement of soot volume fraction in micro-gravity combustion research. LII, in conjunction with other optical imaging techniques, provides unparalleled temporal and spatial resolution, yielding sensitivity and insight into soot formation and oxidation processes (see fig. 17). Present methods of measuring soot volume fraction are limited to line-of-sight methods. These methods offer poor temporal and spatial resolution and require assumptions about the path length and physical properties of the soot.

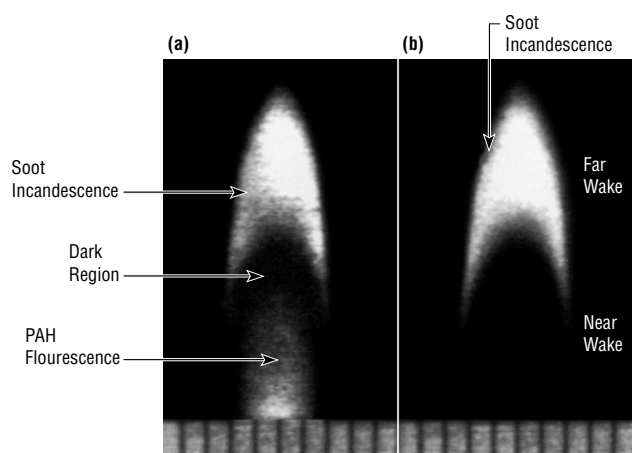

FIGURE 17.—Simultaneous LIF-LII image of burning fuel droplet of decone using (a) 266 nm excitation, and (b) separate LII image using 1,064 nm excitation.

LII utilizes the spatial and temporal properties of pulsed laser excitation to heat soot to far greater temperatures than ordinary flame temperatures and exploits the resultant blue-shifted incandescent emission from the laser-heated soot. The incandescence is predicted theoretically to be a measure of soot volume fraction, which is the feature of soot that

governs many physical processes such as radiative heat transfer from flames. LII offers high temporal resolution by obtaining a signal induced by a single laser pulse. The technique is being extended to two-dimensional imaging applications and combined with other diagnostics such as LIF.

Method

LII of soot occurs when intense laser light heats the soot to temperatures far above the background. Theoretical analyses in various literature sources describe the interaction of laser radiation with suspended particles. For sub-microsecond laser pulses, energy balance equations indicate that the energy addition rate greatly exceeds the loss rate from thermal conduction, vaporization, or radiation. For example, the temperature of a soot particle rapidly rises to its vaporization temperature, roughly 4,000 K, for laser intensities of 1×10^7 W/cm² or greater. Thermal calculations show that equilibration of the absorbed energy within the particle occurs rapidly (on the timescale of the laser pulse), but heating of the medium surrounding the particle occurs on a longer timescale. In accord with the Planck radiation law, the particle thermal emission at these elevated temperatures increases and shifts to the blue compared to the non-laser-heated soot and flame gases. Measurements have shown that the LII signal is linearly proportional to the soot volume fraction and may be readily interpreted as a relative measure of soot volume fraction. Absolute calibration of the technique may be made by in situ comparison of the LII signal to a system with a known soot volume fraction. Point measurements are easily performed using a photomultiplier tube/monochromator to provide spectral and temporal discrimination against natural flame luminosity. One- and two-dimensional imaging measurements may be performed using a gated intensified array camera.

Schedule and Milestones

This ATD project was initiated in FY 1994. This effort is defined as a 4-yr effort, to conclude in FY 1997. Accomplishments to date include characterization of the spectral and temporal nature of the LII signal and excitation wavelength dependencies. Linearity between the LII signal and soot volume fraction has also been demonstrated. The technique has been established on a quantitative basis by comparison to light extinction and gravimetric sampling. Current investigations are completing the technique verification milestone by examining photochemical interferences and the effects of soot aggregate composition and size upon the LII signal, and by combining LII with other comparative

diagnostics such as LIF. The final project milestone is a demonstration of the technique in a reduced-gravity environment.

Application and Technology Transfer

Soot concentration and its spatial distribution are central to several types of combustion processes. As soot nucleation and growth species, polycyclic aromatic hydrocarbons (PAH) play a key role in soot formation and growth processes. The presence of PAH's is indicative of excess fuel and indicates the potential for further molecular growth, leading to material coalescence and, ultimately, soot formation. PAH's arise through fuel pyrolysis reactions and represent the beginning stages of material transformation into soot. The spatial location of fuel pyrolysis regions containing PAH's, relative to soot containing regions, allows assessment of the temperature and time necessary for soot formation along flow trajectories.

By controlling the laser intensity and wavelength, PAH's and/or soot may be detected by the same excitation laser pulse. Ultraviolet laser light at 266 nm will readily excite PAH's, while near-infrared light at 1,064 nm will not produce visible or ultraviolet fluorescence. At sufficient laser intensities, either wavelength can excite incandescence from soot. Time-resolved images of liquid-fuel wick flames and gas-jet diffusion flames provide further support for the spectral identification of the LIF and LII signals presented here.

As illustration of these excitation/detection possibilities, figure 17a illustrates a simultaneous LIF-LII image of a fiber-supported burning fuel droplet obtained using 266 nm light. Figure 17b illustrates an LII image of another burning fuel droplet at the same time in the burning history, using 1,064-nm light. As seen in the LIF-LII image of figure 17a, a distinct minimum or "dark region" in the LIF-LII intensity occurs between the PAH- and soot-containing regions.

The decrease in the LIF intensity with increasing axial height likely reflects the decreasing PAH concentration through rapid coalescence into condensed-phase soot-precursor material. The lack of incandescence in the "dark region" is consistent with the soot-precursor material lacking sufficient solid-state structure to incandesce upon rapid heating by the high-intensity laser light. With increasing temperature and time, the soot-precursor material gradually transforms into a solid-state material capable of incandescence, as observed by the increase in the LII intensity with increasing axial height above the "dark region."

Such images illustrate the advantage of using the combined measurements to visualize the entire soot formation process proceeding from the gaseous PAH's to solid carbonaceous soot. The boundary between the PAH- and soot-containing regions identifies the location of soot-precursor material. This material is produced through the rapid coalescence of PAH's and other fuel pyrolysis products. A key advantage of the optical techniques is that this region is readily identified without using intrusive probe sampling. Since two-dimensional LIF-LII images may be obtained with a single laser shot, PAH- and soot-containing regions in a variety of transient combustion processes may be visualized as illustrated here for the fiber-supported burning fuel droplet. In summary, simultaneous LIF-LII images readily identify the fuel pyrolysis region, the region containing soot-precursor material, and the soot-containing region.

Researcher and Development Center

Dr. Randall Vander Wal
NASA LeRC
21000 Brookpark Road
Cleveland, OH 44135

Phone: (216) 433-9065
E-mail: randy@rvander.lerc.nasa.gov

Ceramic Cartridges via Sintering and Vacuum Plasma Spray

Objectives

NASA MSFC is using plasma spray in a low-pressure, inert environment to form containment cartridges to be used for growing single crystals of semiconductors in micro-gravity. This process uses high-energy (100 kW) plasma to apply layers of refractory metals and ceramics on a graphite mandrel. The deposit is removed from the mandrel as a monolithic part, which becomes the containment cartridge. A variety of materials are being characterized and evaluated against a demanding set of requirements, including high service temperature (1,200–1,600 °C), oxidation resistance, and resistance to liquid semiconductor attack. The advantage of plasma spray forming is the ability to utilize combinations of materials, such as tungsten and alumina, that are difficult to form using conventional techniques. The goal is to develop techniques to form multiple layer containment cartridges using the best combination of refractory metals and ceramics for a particular application.

Method

The fabrication sequence used to form these cartridges incorporates up to three layers of material in a monolithic structure. Each of these layers is deposited on a removable mandrel using the vacuum plasma spray (VPS) process (see figs. 18 and 19). The first layer sprayed forms the inside surface of the cartridge. Its function is to contain the liquid crystal-growth material should the ampoule surrounding it rupture. Ceramics such as alumina and boron nitride are inert to many of the semiconductor materials used in these experiments. However, while providing excellent chemical and oxidation resistance, ceramics are too brittle to have sufficient handling strength in the thickness range (0.65 mm) of interest. Consequently, a second layer of refractory metal is sprayed to provide bulk structural strength of the cartridge for room-temperature handling and high-temperature operation. The third layer is an oxidation-resistant material (probably ceramic) which protects the underlying refractory metal from high-temperature oxidation.

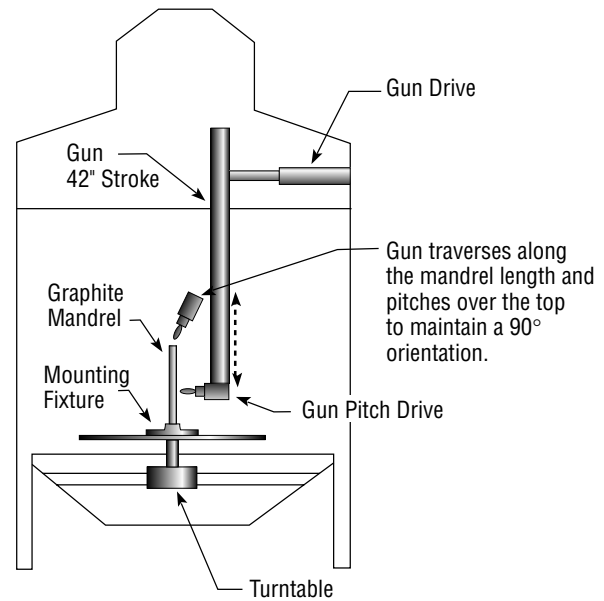

FIGURE 18.—VPS chamber.

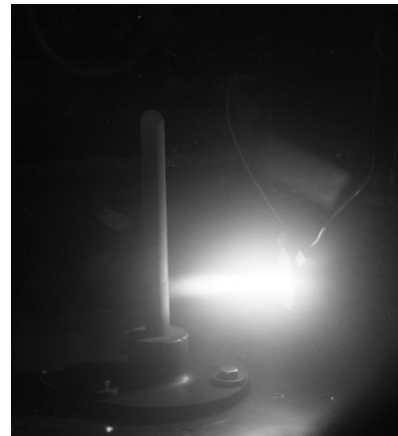

FIGURE 19.—VPS chamber interior.

Graphite is used for the mandrel material because of its stability at the high spray temperature and its resistance to the effects of high thermal gradients imposed by the plasma. The graphite does not metallurgically bond to the sprayed coating, allowing the coating to be pulled off the mandrel after spraying. High thermal expansion (8.6 microns/(m) (°C)) graphite is used to further ease removal, since it contracts at a greater rate than the deposit as the system cools.

These mandrels are rotated about their vertical axes on

a turntable while the plasma torch traverses up and down. A constant thickness, nominally 0.025 in (0.65 mm), of material is applied over the length of the mandrel. The plasma torch is pitched from a horizontal spray axis to nearly vertical in order to coat the closed, hemispherical end of the mandrel.

The photograph in figure 19 shows the plasma torch inside the VPS chamber as it applies tungsten to a graphite mandrel. A thick buildup of material is formed at the other (bottom) end of the mandrel, which allows machining of an interface and flange at the end of the cartridge. The advantage of this forming technology over conventional processes is the elimination of two joining steps used to attach the flange to one end of the cartridge and a hemispherical cap to the other. By spray forming the cartridge as a single part, tolerances of parallelism are more easily maintained.

Schedule and Milestones

Parameter development and deposit characterization have been completed for a variety of refractory materials, including tungsten, molybdenum, tantalum, niobium, rhenium, alumina, and boron nitride. Future efforts will deal with issues of finish machining of the spray-formed cartridges, material properties, and meeting performance and integration requirements of various flight experiments. Investigation of spray-formed material compatibility and resistance to attack by the semiconductors of interest will continue and expand to cover other semiconductor material of interest to microgravity scientists. The goal is to develop and qualify vacuum plasma spray-formed containment cartridges for future microgravity experiments on the space shuttle or in the Space Station Furnace Facility.

Application and Technology Transfer

Representatives of several industries and government facilities, with a wide variety of coating and forming interests, have visited the Plasma Spray Forming Facility at MSFC. VPS has been of particular interest to manufacturers of refractory crucibles and passively cooled rocket nozzles. Other companies, interested in eliminating environmentally suspect operations, have asked for technical assistance in adapting this process for use in deposition of hard coating to replace chrome plating, and conductive coatings for copper electrical contacts to eliminate cadmium plating.

Recently, a local SBIR contractor demonstrated the feasibility of integrating leak-detection sensors into VPS-formed containment cartridges. A prototype sensor has been fabricated and tested with a VPS cartridge that detected the presence of antimony vapor inside the cartridge within 10 °C of the melting point. If successfully developed, such a sensor would provide the only nonintrusive sensor for leak detection of semiconductor material inside the cartridge during crystal growth.

Researcher and Development Center

Mr. Frank Zimmerman
Mail Code EH23
NASA MSFC
Marshall Space Flight Center, AL 35812

Phone: (205) 544-4958
E-mail: Frank.R.Zimmerman@msfc.nasa.gov

Appendix B

Technology Developments and Requirements Descriptions

B.1 ***Biotechnology***

B.1.1 ***Technologies***

Following are brief descriptions of the technologies listed in section 3.1.1. Items marked with an asterisk were developed under the ATD Program.

3.1.1.1 ***Protein Crystal Growth Vapor-Diffusion Flight Hardware and Facility***

The objectives of this research are to provide a user-friendly interface between ground-based and flight PCG hardware, increased (common) availability of flight hardware, elimination of the late-access requirement, and individual loading by the PI. The Protein Crystallization Apparatus for Microgravity (PCAM) was successfully demonstrated as a flight article aboard STS-63, STS-67, and STS-73, the second United States Microgravity Laboratory (USML-2) mission. The Diffusion-Controlled Crystallization Apparatus for Microgravity (DCAM) was developed, constructed, and flown, as part USML-2.

3.1.1.2 ***Protein Crystal Growth in Microgravity***

Automated dynamic control of protein crystal growth (DCPCG) using controlled vapor diffusion has been used to study the effect of varying the evaporation rate on the crystals obtained for a given solution condition. The apparatus system incorporates a static laser light scattering subsystem—consisting of a laser, photodetector, and fiber optics—which allow the evaporation profile to be modified in response to nucleation events. This system has shown that detection of nucleation and modification of the evaporation profile while the experiment is in progress can improve the crystal growth results.

3.1.1.3 ***Membrane Transport Phenomena***

This investigation addresses how gravity influences fluid boundary layers that are associated with membranes, and how the related membrane mediated mass transport processes are affected. The primary variable in the proposed experiments is the convective environment within the test solutions, of which there are three modes: induced convection (gravity >1g), inhibited convection (gravity <1g), and forced convection (externally applied stirring). All the experiments will be performed for each of these three convective modes. Kinetic differences between gravimetric orientations will indicate experimental conditions where microgravity effects are likely.

3.1.1.4 ***An Observable Protein Crystal Growth Flight Apparatus***

Research and development was initiated toward the design and flight of an observable protein crystal growth apparatus (OPCGA). Candidate biochemical systems that included proteins, nucleic acids, and viruses were identified and characterized. An optical platform was constructed that would be suitable for detailed interferometric analysis of PCG experiments and the visualization of concentration fields, the time-lapse microphotography of macromolecular crystals, and the further characterization of the mechanisms and fundamental parameters that determine the features of macromolecular crystal growth. Crystallization experiments accomplished in 1995 included experiments in the ESA Advanced Protein Crystallization Facility (APCF) on STS-65, the Second International Microgravity Laboratory (IML-2), the first flight of the Hand-Held Diffusion Test Cell (HHDTC) on STS-63 Spacehab, and flash-frozen to thaw liquid-liquid diffusion samples in the gaseous nitrogen (GN₂) Dewar aboard the Russian space station *Mir*.

3.1.1.5

Enhanced Dewar Program

A program is being developed to screen protein crystallization conditions, using the batch and liquid-liquid crystallization method. A Dewar flask with small crystallization samples will be frozen on Earth and allowed to passively thaw in microgravity. The crystals are examined by standard light, electron, and atomic force microscopy. Crystal structures are determined and analyzed. Design and development of temperature control and monitoring enhancements to the Dewar apparatus were initiated.

3.1.1.6

Investigation of Protein Crystal Growth Mechanisms in Microgravity

An apparatus is being developed to allow for interactive crystallization experiments on-orbit via telerobotics. The Canadian-American Crystallization Hardware (CATCH) provides either liquid-liquid or mixed-batch protocols for crystallization, with a unique mixing mechanism. A laboratory-based control system is used to monitor remotely the progress of a crystallization experiments and provides users on the Internet the ability to control the monitoring camera and capture an image of the individual sample wells. The first version of the control software is run on the World Wide Web (WWW). Dynamic light scattering experiments have begun to examine the states of aggregation of protein in bulk solution and around various faces of a protein crystal.

3.1.1.7

Advanced High Brilliance X-Ray Source

The primary objective of this task is to produce the first x-ray generator and Kumakhov lens system optimized in design for 8.0 KeV x rays. This task is part of the development of an extremely bright x-ray source for application in the evaluation and determination of the atomic structure of crystalline matter. Potential applications include medical imaging.

3.1.1.8

Rotating Wall Perfused Vessel Bioreactor Technologies

This project seeks to develop and apply slow rotating wall perfused vessel bioreactor technologies for cell and tissue culturing in a simulated microgravity environment. These technologies include subsystems for oxygenation; media replenishment; carbon dioxide (CO₂) and waste

product removal; temperature control; glucose, pH, oxygen (O₂), and CO₂ monitoring and control; cell/tissue sampling and preservation; and computer systems.

3.1.1.9

Experimental Control Computer System

The Experimental Control Computer System is a flight-configured, compact, 486 central processing unit (CPU)-based control and data acquisition system for microgravity science applications. It incorporates personal computer (PC) MCIA-removable memory and program cards, and provides data interfaces with individual experiment hardware systems, racks, and space vehicle data bus when telemetry capability is required.

***3.1.1.10**

Crystal Growth Instrumentation Development—A Protein Crystal Growth Studies Cell

A Protein Crystal Growth Analysis Chamber (PCGAC) and associated techniques continue to be developed to study crystal growth processes and long-term storage techniques for proteins. Aspects of growth to be facilitated for study include solution concentration gradients and interfacial features of crystals under growing and etching conditions. The apparatus will facilitate remote manipulation of growth parameters (temperature, etc.) and data collection. Long-term storage capability is anticipated to be of increasing importance as longer duration microgravity and 1-gravity experiments become increasingly available.

3.1.1.11

Microencapsulation of Drugs

Microgravity research has developed a new drug delivery system consisting of multilayered microcapsules that resemble miniature liquid-filled balloons up to 10 times larger than white blood cells. The outer polymeric membrane of the microcapsules allows the drugs inside to diffuse out at rates controlled by the polymer composition and thickness. The initial microcapsules were designed for “chemoembolization” treatment of vascular tumors. The antitumor drugs are delivered directly into the tumor by injecting the microcapsules into the main artery wherein they form emboli which: (1) reduces the blood supply to the tumor, and (2) provides sustained release of cytotoxic drugs to tumor cells. A dense radio-contrast oil has been co-encapsulated, which makes it possible to radiographically monitor the accumulation of these microcapsules to verify that they have

lodged in the tumor arterioles. So far, six different drugs have been encapsulated in microgravity, including two anti-tumor drugs, an immune stimulant, an antibiotic, a clot-dissolving enzyme, and an anti-nauseant. Crystals of drugs have been encapsulated, which means that the interior lining of the blood vessels can be protected from the sharp crystal edges by the soft pliable outer membrane of the micro-capsules. Administration of drug crystals is a way of providing maximum sustained drug release and long-term delivery of the drug from each injection.

***3.3.1.12**

Space Bioreactor Bioproduct Recovery System

A major focus of MSAD's biotechnology program has been the development of space bioreactors that can be used aboard spacecraft to overcome gravity-induced limitations in cell culture and tissue engineering. The current generation of space bioreactors can support some aspects of long-duration cell cultures, but cannot be used to separate and preserve or remove the bioproducts. Some of the bioactive molecules present in trace quantities in the bioreactors are valuable, while other biomolecules present can act as cell inhibitors and either lead to termination of cellular production of desired molecules or to cell death.

The purpose of this effort is to develop a BRS that allows the selective removal of molecules of interest from space bioreactors, thus enhancing the productivity of those bioreactors. Specifically, the BRS is designed to target specific biomolecules or waste products, to continuously adsorb and separate biomolecules from dilute bioreactor effluents, and to stabilize and preserve targeted bioproducts. The BRS will also be miniaturized to meet volume and power constraints and designed to operate in microgravity. The BRS is integrated into the space bioreactor perfusion loop. Bioreactor fluid flows from the perfusion loop into the BRS cartridges, each of which is packed with an adsorbent that binds, separates, and retains substantial quantities of the bioproduct(s) of interest. During operation of the bioreactor, as the BRS cartridges become fully or partially saturated with bioproducts, they can be removed for storage or processed further. Further processing may involve flushing the saturated cartridges with solutions that either remove degradative molecules or preserve and stabilize the bound bioproducts' integrity and activity. The BRS concept

revolves around two distinct systems: an on-line system, in which bioreactor media continuously flow through the BRS cartridges, and a downstream system, in which spent media from the bioreactor flows in a single pass through the BRS cartridges. Each BRS contains several adsorption cartridges that contain specific-affinity adsorbents for targeted biomolecules or waste products. A circulation pump and pressure-sensing devices are used to control the flow of liquid through the two systems.

3.1.1.13

Sensor Technologies

As part of the NASA JSC Biotechnology Program, the Sensors and Controls Research and Development (R&D) Laboratory is developing new, state-of-the-art sensor and control technologies that will be an integral part of NASA JSC perfused microgravity bioreactor systems. These technologies are considered enabling for development of fully automated tissue engineering systems that utilize a minimum of operator time and consumable resources, while providing a physiological environment for cell and tissue culture. Critical biologic parameters to be monitored and/or controlled are: hydrogen ion, glucose, oxygen, carbon dioxide, biomass, glutamine, and lactate concentrations. An amperometric glucose oxidase-based biosensor previously developed for in vivo glucose monitoring has been adopted and redesigned. The sensor has been integrated with a rotating-wall microgravity bioreactor to continuously and independently monitor the bioreactor glucose level. The developed sensor has been extensively tested in various bioreactor conditions. Effects of several factors (i.e., media pH, dissolved oxygen, perfusion flowrates, long-term exposure) on sensor performance have been determined. Glucose concentrations in cell culture media have been monitored continuously for a period over 21 days. Monitoring of pH in perfused microgravity bioreactors is performed continuously and noninvasively by the optical pH sensor developed by NASA JSC. Cell culture media pH is measured indirectly by the sensor via detection of the light frequency transmitted through Phenol Red, a common pH indicator in cell culture media. The sensor then converts the frequency to a pH reading. The optical pH sensor has been integrated into a NASA-developed perfused microgravity bioreactor.

B.1.2 ***New Technology Requirements***

Following are brief descriptions of the new technology requirements listed in section 3.1.2.

3.1.2.1 ***New Optical Technique for Protein Crystal Growth Diagnostics***

An optical system for observing protein crystals as they nucleate and grow is needed. Standard microscopy is limited in resolution to about a half of wavelength of light, and electron and x-ray microscopy cannot overcome the diffraction limit. A near-field scanning optical microscope (NSOM) has a sub-micron resolution and is proposed for observation of a growing protein crystal. Resolution of 10-nm patterns has been shown. With the use of fluorescent labels, discrimination between single molecules and aggregates can be accomplished when they are separated by as little as 40 nm. A tapered fiber probe for immersion in growth solutions has also been proposed as an integral part of the NSOM optical system. Optimization of the system for the unique application of PCG is needed. If successful, observation of how monomers (single molecules) orient and form into a nucleus may be possible. In addition, optical monitoring of the surface of the growing crystal may be achieved.

3.1.2.2 ***Development of Improved Rotating Wall Perfused Vessel Bioreactors***

Previously developed rotating wall perfused bioreactors have been used to simulate many of the low-gravity conditions of space for ground-based mammalian tissue culturing. However, these systems are difficult to operate and maintain. Improved rotating wall bioreactors have been designed for improved long-term reliability and maintainability for both ground-based research and space flight experiments. The new systems have enhanced capability to remove sterile samples of cells and culture medium with a minimum disruption of the tissue-like spheroids of cells growing together. Improved process control parameters and reduced levels of hydrodynamic stress on the cells is accomplished by more precise control of rotating speeds of the inner core and outer wall. Key design issues include sterilizable components, improved materials compatibility, and reduced cell toxicity for longer term studies of multiple types and tissue-like cellular constructs.

3.1.2.3 ***Development of Alternate Bioreactor Systems for Culturing Mammalian Cells and Tissues in Space***

These systems include automated Perfused Stationary Culture Systems (PSCS) which incorporate cells attached to a large area surface wherein the nutrient requirements and removal of cellular waste products is accomplished by slow perfusion of culture medium over the entire culture surface such that cells at the distal end of the system receive the same nutrients as cells at the perfusion inlet. These flight systems allow for long-term culture of cells which are anchorage dependent, but are not suitable for growth on microcarriers. Passive Culture Systems (PCS) include autonomous small flight hardware for maintaining living cells and performing simple, short-term experiments under microgravity conditions. The PCS systems have a limited gas storage capability for oxygen (maximum content ~40 percent) and, therefore, are not suitable for long-term experiments. Flight designs include use off-the-shelf plastic-ware, special sterile injection and sample ports, and different size culture chambers ranging from 0.8 to 4.4 L.

3.1.2.4 ***Cell/Tissue Metabolism Sensor and Control Subsystems***

Cell metabolic sensors are crucial for proper process control of the culture microenvironment within the cell culture systems. Earth-based sensor systems for oxygen, carbon dioxide, pH, glucose, and other metabolic parameters do not function adequately in microgravity, therefore, modifications, minaturization, and repackaging are necessary to provide accurate real-time data for control subsystems that minimize expendables for long-duration space flight culture systems. Effects of space radiation on reliability and certain computer memory systems must also be assessed and, if necessary, software must be developed that can prevent loss of critical control or experimental data. The current designs include interface with laptop computers and telemetry links for program updates or malfunction diagnosis.

3.1.2.5 ***Advanced Media/Nutrient Supply and Replenishment Subsystems***

Advanced media/nutrient supplies and replenishment subsystems are required to minimize fluid and mass

requirements for long-duration microgravity culture systems. Dissolved waste products, proteins, and gases all must be eliminated to prevent the build-up of toxic levels within the perfusion medium. Optimum control of pH normally requires periodic addition of basic chemicals and concentrated volumes of glucose, growth factors. Metabolic nutrients must also be added frequently. Diffusion or dialysis methods can be utilized; however, injection of concentrated additives must be carefully controlled by adequate mixing and dilution prior to exposure to the cells. This requires precise chemical sensors, fluid subsystems (often requiring refrigeration), and process control parameters to carefully control, resupply, or replenish the culture medium perfused over the cells.

3.1.2.6 ***Development of Microgravity-Based Bioreactor Systems Technologies***

Development of automated microgravity-based bioreactor systems technologies for new therapy design, tissue engineering, and tissue transplantation include bioreactor systems for experiments on the Russian Priroda module, which include the bioreactor module or BTS experiment module (BEM–BSTC), a gas supply module (GSM), BTS computer module (BCM), and other support

facilities (BTR, etc). The overall system is programmable by interfacing with a laptop computer or by replacing PC MCIA cards containing new control programs.

3.1.2.7 ***Cell/Tissue Oxygenation and Waste Gas Removal Subsystems***

Optimum maintenance of oxygen levels and waste gas removal requires special subsystems that provide precise control of dissolved gases and eliminate any bubble formation that can denature proteins in the nutrient medium. Special gas supply and control subsystems are required which maximize recycling of the atmosphere gases and minimize waste gas dumps into the cabin atmosphere. These include provisions for sterilizing the gases before reuse in the gas exchange subsystem within the bioreactor modules.

3.1.2.8 ***Development of a Thermally Controlled Sample/Experiment Storage System.***

There is a need for a thermally controlled sample/experiment storage system capable of maintaining a stable thermal environment during short-duration *ISS* power brownouts and blackouts.

B.2 Combustion Science

B.2.1 Technologies

These are brief descriptions of the technologies listed in section 3.2.1. Items marked with an asterisk were developed under the ATD Program.

3.2.1.1 Light Sheet Flow Visualization and/or Velocimetry

Visualization of flows usually involves seeding the medium with dyes or particles. The relative intensity of fluorescence or scattering may be used to indicate the extent of mixing. By comparing two images, velocity vectors can be ascribed to the flow field, as is done in particle image velocimetry (PIV). Both gaseous and liquid flows may be visualized and quantified with appropriate seeding, using a planar laser light-sheet for excitation of fluorescence or scattering from the seeded species. A variation of this technique is used to detect fluorescence from aromatic species transported back to the droplet surface from the flame in droplet combustion experiments. Such transport of rather nonvolatile species may be involved in droplet microexplosions.

3.2.2.2 Laser Doppler Velocimetry

By using crossed laser beams, an interference pattern can be created. A seeded particle moving across the interference fringes creates a time-varying scattering signal. The modulation frequency of the scattered signal yields the particle velocity and, hence, the gas velocity for a given light fringe pattern spacing.

***3.2.1.3 Microgravity Combustion Diagnostics**

A variety of methods for detecting and quantifying combustion processes are being investigated. The primary focus is to advance the technologies associated with making noninvasive measurements.

***3.2.1.4 Determination of Soot Volume Fraction via Laser-Induced Incandescence**

LII is being studied for use as a two-dimensional imaging diagnostic tool for measuring soot volume fraction for microgravity combustion research. This method would offer more detailed information about combustion processes than present line-of-sight measurements.

B.2.2 New Technology Requirements

These are brief descriptions of the new technology requirements listed in section 3.2.2.

3.2.2.1 Soot Temperature Measurements Using Pyrometric Techniques

In two-wavelength pyrometry, measuring the radiant energy due to soot within a flame at two different wavelengths, the temperature of the soot may be inferred. The technique, strictly passive in nature, requires only appropriately calibrated detectors. The calculated temperature of the soot reflects that of the ambient gaseous environment.

3.2.2.2 Liquid Surface Temperature and Vapor Phase Concentration Measurements via Exciplex Fluorescence

Exciplex thermometry uses an additive that forms a complex when electronically excited. Since the concentration of the complex is temperature dependent, and since it fluoresces at different wavelengths than the original compound, the ratio of the fluorescence intensities from the parent and complex can, with suitable calibration, yield a measure of temperature.

3.2.2.3 Liquid Phase Thermometry and Fluorescence of Aromatics

Liquid phase thermometry and fluorescence of aromatics are used to evaluate droplet surface transport and internal flow.

B3

Fluid Physics

B.3.1

Technologies

Following are brief descriptions of the technologies listed in section 3.3.1. Items marked with an asterisk were developed under the ATD Program.

3.3.1.1

The Mechanics of Granular Materials

The Mechanics of Granular Materials (MGM) is an apparatus designed to develop a quantitative understanding of the constitutive behavior of dry and saturated sand when crushed under very low confining pressures in a microgravity environment

***3.3.1.2**

Stereo Imaging Velocimeter

This project will provide a method to measure three-dimensional fluid velocities quantitatively and simultaneously by mapping and tracking multiple tracer particles whose locations are determined from two camera images. One use of this technology involves multipoint particle tracking during convective flow studies.

***3.3.1.3**

The Laser-Feedback Interferometer

This project will develop an instrument that uses a laser both as a light source and a phased detector in order to determine phenomena that are dynamic and that vary slowly over time in microscopic and macroscopic fields of view. This technology could have applications in several scientific fields, but especially, fluid physics and transport dynamics discipline experiments would benefit from accurate measurements of the change in the optical path length.

***3.3.1.4**

Passive Free-Vortex Separator

Future long-term experiments will require that gas-liquid mixtures be separated into single-phase states prior to reuse or recycling. The passive free-vortex separator will be developed under an ATD project to separate two-phase fluid mixtures in microgravity.

***3.3.1.5**

Surface Fluctuation Spectrometers

In this project, an instrument will be developed and demonstrated which uses a cross of scattered laser light to discriminate against multiply-scattered photons and select singly-scattered light. This will allow particle size characterization in turbid media; conventional light scattering methods yield significantly undersized results. This extends the use of laser light scattering by several orders of magnitude in concentration. The technology permits closer approach to critical points in critical fluid experiments and examination of binary mixtures in colloid suspensions. Industrial interest is strong.

B.3.2

New Technology Requirements

Following are brief descriptions of the new technology requirements listed in section 3.3.2.

3.3.2.1

High-Resolution, High-Frame-Rate Video

Commercially available technology that provides a video resolution of up to 1,000×1,000 and/or 1,000 frames/sec acquisition rate is under evaluation.

3.3.2.2

Improved Data Storage and Downlink Technologies

Digital video data storage/compression. Commercially available data storage technology which will support capacities of up to 2,000 GB of digital video data is under investigation. In addition, data compression techniques, including JPEG, MPEG-II, and Wave-let technology, are being evaluated as possible compression techniques for real-time science operations.

3.3.2.3

Three-Dimensional Particle Tracking

A nonintrusive three-dimensional full field velocity measurement device will provide an improved method to measure three-dimensional fluid velocities quantitatively and simultaneously by mapping and tracking multiple tracer particles.

3.3.2.4

Diagnostics Technologies for Opaque Fluids (e.g., "Melts")

Work needs to be done in transparent melts and in x-ray sources areas.

3.3.2.5

Nonintrusive Three-Dimensional Full Field Fluid Velocity Measurement Device

Interest spans a wide range of velocities and fields of view.

3.3.2.6

Nonintrusive Three-Dimensional Full Field Fluid Temperature Measurement Device

The interest covers a broad range of temperatures and precision. For example, it would be desirable to know the temperature distribution in the Bubble, Drop, and Particle Unit (BDPU) experiment. The interesting aspect is the three-dimensional rather than surface properties.

3.3.2.7

Ultrasonic Phase Distribution Measurement for Multiphase Flows Through an Opaque Tube

The opaque tube makes this an interesting problem. Ultrasound is an old and well-verified technique, but it may lead to new technology development.

3.3.2.8

Nonintrusive Digital Pattern Recognition and Phase-Boundary Locator

Data analysis would be much easier if a digital pattern recognition method could be used to analyze the video image and calculate bubble/drop velocities, which presently require tedious analysis.

3.3.2.9

Nonintrusive Three-Dimensional Surface Shape Measurement With Sub-Micron Measurement Capability

There are lots of measurement options here, sub-micron axially and transverse. Lots of other interferometric or shearing (grating) techniques. Application to moving, low-reflectivity fluids could be a challenge. This technology has application in the area of moving contact line.

3.3.2.10

Improved Twyman-Green Interferometer With 1/30 Wavelength Resolution Capability

Significant advances in this area have been achieved by the critical fluids group at LeRC, who expressed interest in the 1/30 wavelength resolution capability.

B.4 **Fundamental Physics**

B.4.1 **Technologies**

Following are brief descriptions of the technologies listed in section 3.4.1. Items marked with an asterisk were developed under the ATD Program.

3.4.1.1 **Copper Ammonium Bromide (CAB) High-Resolution Thermometers**

To perform the extremely precise temperature measurements required for the Lambda Point Experiment (LPE), the LPE team at Stanford University, under the direction of Professor John Lipa, developed HRT's that can resolve temperature differences smaller than 10^{-9} degrees. Along with the thermometers, an experimental platform capable of controlling He samples to sub-nanokelvin stability was also developed. These MSAD-developed thermometers are now recognized by the scientific community as the state of the art in temperature measurement. Improved HRT's—the HRT's developed for the LPE demonstrated higher noise levels in the space environment due to cosmic ray heating. The Confined Helium Experiment (CHeX), scheduled to fly in November 1997 as part of the USMP-4 mission, has developed HRT's with faster response time to minimize this problem. These new thermometers also demonstrate improved sensitivity, being capable of resolving temperature differences below 10^{-10} degrees. Dr. Rob Duncan's Critical Dynamics in Microgravity Experiment (DYNAMX) is replacing copper elements of the HRT with aluminum to reduce the cross section for cosmic rays. These improvements to the HRT's have the potential to enhance results measured in space.

3.4.1.2 **Compact, Inexpensive High Field Gradient Superconducting Magnets**

These unique magnets were developed with NRA funding by JPL researchers, in partnership with Oxford Instruments. The magnets provide a field times field gradient product above $22 \text{ T}^2/\text{cm}$, making them suitable for canceling hydrostatic pressure gradients in samples in Earth-based laboratories such that an effective gravity environment near 0.01 g is sensed by the sample. These magnets have been used to directly levitate He samples.

***3.4.1.3** **High-Resolution Capacitive Pressure Transducer**

A simple to construct and assemble high-resolution capacitive pressure transducer is being developed at JPL under the ATD Program (see 3.5.1.9). This device is based on a capacitive read-out technique and involves precision micro-machining of silicon wafers. The transducer has demonstrated a resolution of one part in a billion at pressures in the 10-bar range.

***3.4.1.4** **Single Electron Transistor (SET)**

The SET, being developed at JPL as an ATD task, is an extremely sensitive detector of electric charge, with the potential to detect charge differences as small as $10^{-6} e/(\text{Hz})^{1/2}$ (e is the charge on an electron), an improvement of over a million-fold beyond what other charge detectors can do. SET's are expected to find wide-scale application in high-resolution measurements of the future. For example, they could perform as readout amplifiers for capacitive gauges that can measure pressure, density, dielectric constant or the temperature. The SET will enable new kinds of measurements to be performed with very high resolution. Other very important applications for the SET's are as charge readouts for IR-sensitive bolometers for use in astrophysics missions. Estimates of an improvement in the bolometer performance of about 3 orders of magnitude are predicted, which would enable researchers to probe the universe with unprecedented resolution. In FY 1996, demonstration devices were fabricated.

***3.4.1.5** **High-Resolution Thermometry and Improved SQUID Readout**

The goal of this project at GSFC is to advance the state of the art of high-resolution thermometers and SQUID's. Key features of the thermometer are fast response time and potential immunity to cosmic ray effects on orbit. A special Two-Stage SQUID Amplifier (TSA) also is being investigated that would be useful for ground applications, such as magnetometers for biological, geological, and chemical research. The TSA is an improved version of the SQUID that cascades two stages of SQUID amplifier, using a single SQUID in the first stage and 100 SQUID's in the second, to obtain lower noise levels and wider dynamic range. Successful development of the TSA would enhance many of the low-temperature and fundamental physics experiments proposed for Earth orbit.

3.4.1.6

Prototype Miniature High-Resolution Thermometer

Drs. Inseob Hahn and Martin Barmatz are using NRA funds to develop a miniature HRT. A prototype has been fabricated and preliminary tests have been performed. The device utilizes a Samarium Cobalt magnet to trap the initial magnetic flux in the circuit and standard salt pill technology for the thermometer itself. The main advantage of the new design is that it obviates the need for a massive electromagnet to do the initial field trapping. The HRT itself is also much reduced from the size used in previous flight experiments, offering the promise of improved designs to reduce the amount of heating experienced during launch of future low-temperature experiments.

3.4.1.7

Magnetic Levitator for Liquid Helium

Researchers at Brown University have developed a magnetic levitator for liquid He. They are using it to study drop dynamics of He drops up to several millimeters in diameter under varying conditions.

3.4.1.8

Electrostatic Levitator for Liquid Helium Drops

Researchers at University of Oregon have developed an electrostatic levitator for charged He drops.

***3.4.1.9**

Magnetostrictive Low-Temperature Actuators

The objective of this project is to use the unique “giant” magnetostrictive properties of terbium, dysprosium, and zinc alloys as the prime mover in a series of actuators and mechanisms which include low-temperature valves, heat switches, precision positioners, and lead screw drivers. These new materials have performance characteristics for low-temperature operation hitherto unavailable in any actuator. These materials, and a family of devices for low-temperature use based on their unique properties of long stroke and high power with negligible energy dissipation, are being developed.

3.4.1.10

Ultra-Sensitive Superconducting Test Mass Accelerometers

Stanford University researchers have made substantial progress over the last few years in developing this critical technology for the Satellite Test of the Equivalence Principle (STEP) program. These accelerometers will be used by STEP to test the weak equivalence aspect of Einstein’s Equivalence Principle, with 6 orders of magnitude better precision than previously accomplished.

3.4.1.11

Measurement of Ultra-Low Pressure at Low Temperature

This work for the STEP project will demonstrate a pressure gauge that measures pressures as low as 10^{-12} torr at temperatures between 2 and 4 K. The technique is based on measurements of the relaxation time of an adsorbed He film. The He film will be measured with either a superconducting film bolometer or a quartz crystal microbalance.

B.4.2

New Technology Requirements

Following are brief descriptions of the new technology requirements listed in section 3.4.2.

3.4.2.1

Digital Signal Processing (DSP) SQUID Technology

While modern commercial SQUID systems display adequate resolution for the precise temperature measurements for which they are employed in this program, the SQUID’s are disrupted by EMI and have limited ability to track a fast-changing input signal. With the rapid application of fast digital processors to instrumentation, new SQUID systems are being built that employ DSP’s to amplify the signals generated by a dc SQUID. The speed of the DSP allows the output to track rapidly-varying signals. These systems promise to simplify the employment of SQUID’s in the EMI-rife environment of the Space Transportation System (STS) and *ISS*. A small effort to develop DSP SQUID systems has been started at JPL and the University of New Mexico, showing better immunity to EMI and promising results similar to those demonstrated by the biomedical systems.

3.4.2.2

Improved Flight-Quality Radio Frequency (RF) SQUID System

SQUID's are an integral part of the HRT's used on the LPE. The LPE SQUID's will be reused on the CHeX. Unfortunately, the company who manufactured these SQUID's, BTI, no longer produces or supports this relatively old product. Additionally, many of the components used in the BTI SQUID's are no longer available. This has left a void for future low-temperature experiments desiring to use SQUID technology. An effort is required to develop a currently available and supported commercial SQUID system for use in the space environment. The primary issues are EMI performance, thermal vacuum stability, and the ability to withstand the launch environment.

3.4.2.3

Improved High-Resolution Pressure Transducer

The LPE, CHeX, and DYNAMX experiments all have, or will obtain, data only along the saturated vapor curve, where the pressure above the liquid is maintained at its saturated vapor pressure, of the phase diagram of liquid He. For the brief periods of microgravity available for these STS experiments, this one set of pressure-temperature data is about all that can be managed. In the 3- to 6-mo periods that will be afforded by research on the *ISS*, investigators can explore other pressures, venturing well off the saturated vapor curve, to enrich the data return from their experiments. To maintain elevated pressures with stability comparable to the temperature control allowed by HRT's, improved pressure transducers must be developed. This development task would be aimed at developing such transducers, utilizing superconducting and micro-machining technologies.

3.4.2.4

Vibration Isolation for Cryogenic Systems

Many experiments in low-temperature physics need the microgravity environment of space to enhance data return and to provide study of phenomena not possible on Earth. It is the latter that make a vibration-isolated environment desirable. As the 'DC' microgravity environment enables the study of new phenomena, it also introduces noise sources overwhelmed by other obstructions on Earth (i.e., vibration). Systems are desired that can suppress vibrations in the low-frequency range (>100 Hz) by an order of magnitude or more.

3.4.2.5

Precise Thin Film Lithography on Cylindrical Surfaces

The STEP experiment will levitate hollow cylindrical masses around a cylindrical center shaft. Both the inner cylindrical surface of the levitated mass and the outer cylindrical surface of the center rod must have superconducting traces deposited precisely on their surfaces. In practice, a uniform film will be deposited on these surfaces and then photolithographic techniques will be used to etch the precise pattern required. The printing of the circuit is very similar to the printing techniques used for Xerography, so there are methods in place from which to begin developing the techniques to be used in this task.

3.4.2.6

Long Lifetime Cryogenics Systems for the ISS Facility

As the nominal servicing interval for *ISS* is of the order of 6 mo, and there are experiments in low temperature that need extended test periods, the technology necessary to take maximum advantage of the former, while satisfying the latter, is needed. This can involve the use of external refrigerators (which tend to be noisy) or some other mechanism to cool the outer shell of the system. Other potential technology developments, such as multilayer insulation or the use of novel materials for structural members, may be appropriate to the development of this system technology. Extension of lifetime realized in this task will lead to increased science return for each flight on the *ISS*.

3.4.2.7

Miniaturized High-Resolution Thermometers

Miniaturized HRT's enable new avenues in science to be explored, such as spatially resolved phenomena that are currently not able to be probed due to the confined spaces that are allocated to an instrument. An additional benefit of miniaturized HRT's is that they also may have inherently faster response times than the current paramagnetic salt HRT's. Some version of this size-reduced technology is essential to the concept of multiple experiments within one low-temperature instrument package, which will significantly reduce the average cost per experiment.

3.4.2.8

Flight-Qualified Technology and Instrumentation for Laser Cooling of Atoms

The laser cooling area of low-temperature microgravity physics has not yet flown any experiments in space, so no flight hardware has yet been developed. Much of what is needed for these experiments has been developed and flown on other experiments. This task would develop experimental apparatus designed to survive the rigors of launch and operate well in the *ISS* environment.

3.4.2.9

Visual Access Cryogenic System or Cryogenic High-Speed Video Camera

Four of the ground-based investigations now being pursued in the fundamental physics program require visual access to the experiment cell to obtain their data. Such access is obtained routinely in ground-based Dewars and cryoprobes, but the present flight facility and flight probes do not allow visual monitoring. It seems likely that the access can be managed by lines of sight parallel to the Dewar cylinder axis, so the facility need not be modified, only the cryoprobe insert. Visual access in such experiments could also be provided by a high-speed video camera able to operate at cryogenic temperatures. This task would explore concepts to permit visual monitoring of events in the experimental cell.

3.4.2.10

Flight-Quality Direct Current (DC) SQUID's

The development of SQUID's started with low-frequency RF systems, which went to higher frequencies to improve resolution, and then transformed to dc SQUID's with yet higher resolution and lower noise performance. The commercial market for SQUID's is now moving to the simpler, lower-noise dc SQUID technology. The LPE was begun during the earliest period of SQUID development, and CHeX will use that low-frequency RF technology again in its 1997 flight. However, lowering the noise of the SQUID permits shrinking the size of the sensing element with no loss of signal to noise. The adaptation of commercial dc SQUID's for flight will simplify the miniaturization task, with its enabling of new measurements and simplifying of the launch configuration. Perhaps more significantly, eventually the dc technology will be the only one supported by industry, so replacement parts will likely become unavailable for the RF SQUID's.

3.4.2.11

Flight-Quality DSP SQUID's

The DSP SQUID systems would, under this task, be built to operate well in the thermal, vacuum, and EMI environment of low-Earth orbit, and to survive launch. A DSP chip has been flown on other missions, so this task must be sure to employ one that has demonstrated the immunity to cosmic radiation. This task would essentially take the DSP SQUID system developed under 3.5.2.1 from a ground system to a flight-proven system and demonstrate flight-worthiness by environmental testing.

3.4.2.12

Ultra-High Vacuum Production and Measurement Techniques

The production of ultra-high vacuum, reaching pressures below 10^{-9} torr, will benefit more than one type of low-temperature experiment. The calorimetric experiments, like those presently being flown on the STS, require isolation from the surrounding environment to minimize heat leaks so that temperature drifts are small; pressures in the 10^{-9} to 10^{-10} torr range are desirable. The STEP needs to assure that no convective forces can disturb the levitated masses of that experiment; here, pressures below 10^{-11} torr are required. This task would use sorption pumping and specially developed pressure measurement techniques to demonstrate that such pressures can indeed be obtained.

3.4.2.13

Multiple Experiment Platform for Low-Temperature Physics Experiments

A multiple experiment platform envisioned for low temperature would be an extension of the current technology. This technology development would ultimately lower the cost per experiment, since the cost of a given launch would be apportioned over two or more experiments. This technology also would enhance the access to space for low-temperature scientists, as it is currently limited by the number of launches available and the resources available to support a launch. The new experiment platform for the *ISS* should also minimize the amount of vibration heating experienced during launch, with the ultimate goal of obviating the need to use exchange gas as thermal protection during launch.

3.4.2.14

Low-Noise Cryo-Coolers

Low-noise cryocoolers could be a source of a cryogenic environment alternative to the stored-cryogen systems presently available. The primary shortcoming of today's cryocoolers is that they are sources of significant vibration. This vibration energy perturbs the types of high-resolution experiments performed in low temperature to the point where the data obtained are dominated by the noise source. A hybrid system of low-noise cryocooler and stored-cryogen system could provide a low-temperature, low-noise environment in space for many months.

3.4.2.15

Flight-Quality Dilution Refrigerator

The forefront of ground-based experimentation in condensed matter physics has moved steadily over the past several decades to lower temperatures, now reaching the range near 10 micro-degrees above absolute zero. The method of choice for obtaining temperatures below 1 K is the dilution refrigerator, which permits temperatures below 0.01 K to be maintained for several months. As presently configured, dilution refrigerators employ several phase boundaries that require gravity for their stable location. New concepts have been developed to work around these interface problems, and one is now being explored at JPL with seed money from the Director's Discretionary Fund. At least one experiment proposed to the NASA NRA needs these low temperatures. The combination of ultra-low temperatures in low gravity will provide investigators a new realm of experimental parameters to explore.

3.4.2.16

Flight Qualified GdCl₃ Thermometer

Gadolinium trichloride (GdCl₃) thermometers are extensions of the current copper-ammonium-bromide (CAB) paramagnetic salt thermometers, the difference being the salt utilized. GdCl₃ offers the potential of higher sensitivity in the vicinity of the lambda transition of He, and especially at the higher temperatures of the liquid-vapor critical points of ³He (3.2 K) and ⁴He (5.4 K). GdCl₃ also is a stable material to work with, simplifying the implementation of the HRT. The further development of GdCl₃ HRT's can yield higher resolution than the present ~10⁻¹⁰ K available today from CAB HRT's, so these new devices could improve the science return from low-temperature experiments.

3.4.2.17

Flight-Quality Laser Cooled Atom Trap Facility

The interference of multiple laser beams in a region where an atomic beam of laser-cooled atoms exists can generate areas of force on the atoms that has a pattern of minima and maxima. The valleys and peaks can be used to trap the cold atoms for significant times so they can be studied. For example, their quantum states can be studied by causing transitions between two states and observing the emitted or absorbed radiation. The slowed motion of the cold atoms enhances the precision of such measurements. No flight hardware exists to permit such experiment to be conducted in space to avoid the gravitational drain of atoms from the trap. This task would develop the flight hardware for these experiments.

3.4.2.18

Flight-Qualified ³He Refrigerator

The present facility for low-temperature condensed matter experiments provides a liquid helium bath cooled to temperatures just below 1.8 K, which is fine for experiments exploring the lambda transition at 2.177 K or phenomena at higher temperatures. However, there is a wealth of new phenomena to explore below 1 K; a ³He refrigerator would allow experiments to be cooled to below 0.5 K. Several of the presently funded ground-based studies have expressed the need to obtain sub-Kelvin temperatures for their experiments. A ³He refrigerator would provide such temperatures in the simplest manner. A ³He refrigerator has been developed for space use on an IR mission recently flown by the Japanese, so this task needs only to adapt that technique to the program's heat load requirements and to the geometric constraints.

3.4.2.19

Accelerometers for Use at Helium Temperatures

Accelerometers for use at He temperatures would help experimenters in the post-processing of their data by providing a characterization of the acceleration environment at the He test cell. This characterization would improve the overall quality of the resulting science by minimizing the error band due to a significant noise source, namely, extraneous accelerations. The warm accelerometers used by the Space Acceleration Measurement System (SAMS) require interpolation of the data from the warm location where the data are taken to that point where the test cell is located in the cryostat. Cold accelerometers can be located much closer to the experimental cell, where the accelerations they measure will represent much more accurately the accelerations experienced by the cell.

3.4.2.20

Fast Response High-Resolution Thermometer

Fast response high-resolution thermometry would enable some new areas of physics research. In particular are those areas where it is desired to study transient phenomena where the relaxation time is short. High-speed HRT's also would have the effect of mitigating cosmic ray noise on HRT's, as these data anomalies would be able to be filtered out in post-processing. Alternatively, a high-speed HRT could be used in the study of the cosmic ray environment on orbit. The 10^{-10} K or better resolution is still required of these thermometers, but sampling rates of 100 Hz or more would be enabled. If the present task to develop smaller, faster thermometers does not succeed for lack of sensitivity, other methods to increase the response speed of the HRT's should be explored.

3.4.2.21

Ultra-Sensitive Superconducting Test Mass Accelerometers

STEP needs this system technology to enable achieving their scientific goals.

3.4.2.22

Miniature High-Reliability, Low-Temperature Valve

All low-temperature experiments have a need for highly reliable cryogenic shut-off valves in various forms. In the space station era, the extended experimentation time afforded by the longer cryogenic lifetime will enable experiments to be done at various pressures. Therefore, valves are needed that can be repeatedly and reliably operated in the microgravity environment in order to adjust the sample pressure under investigation.

3.4.2.23

Flight-Quality Ultra-Stable Frequency Standard

Many experiments in the relativity and gravitational physics area and the atomic physics area rely on highly accurate clocks for performing their scientific investigations. To allow researchers in these fields to perform measurements in the microgravity environment of space, flight-qualified clocks are needed

3.4.2.24

High-Precision Germanium Thermometer Readout and Temperature Controller

A Germanium resistance thermometer (GRT) is recognized as a "secondary thermometer," which requires a calibration against a temperature standard. It has been used in the measurement of temperature from 0.05 K to 30 K for many years. Commercially available GRT sensors have a useful temperature range of about two decades. The exact range depends on the doping of the germanium element. Typical resistance values vary from a few ohms (at high temperature) to several tens of kilo-ohms (at low temperature). The thermometer sensitivity increases rapidly with decreasing temperature, and a high degree of temperature resolution can be achieved at low temperatures. Using a standard 4-wire resistance bridge circuit with a low temperature standard resistor, a GRT system can resolve about 1 microKelvin at 4.2 K and below. Typical long-term stability of the sensor is about ± 0.5 milliKelvin. Because of this drifting effect, GRT's need to be calibrated often if absolute accuracy is required. Also, since a GRT shows strong magnetoresistance and associated orientation effects, it is not recommended to be used in a magnetic field.

3.4.2.25

Low-Noise Cryogenic Instrumentation Amplifiers

All cryogenic experiments proposed for NASA missions depend on precise measurements made by electrical sensors located near an experiment cell. The cables between the sensor and the warm readout electronics often are highly susceptible to electrical noise. A low-noise, cryogenic, flight-quality instrumentation amplifier located adjacent to the sensors would amplify the signal before noise is introduced by the cabling.

3.4.2.26

Telescience Flight Software Tools

Software controlling MSAD flight experiments often does not present an efficient, simple interface for the investigator. Each flight project expends a great deal of effort writing and debugging real-time control software. Longer run times for experiments aboard the *ISS* will greatly increase operating costs unless investigators can control their experiments directly through simple, reliable remote interfaces. Ground-based experimenters have solved these problems with graphical real-time programming languages (i.e., Labview). The reliability, response time, and hardware compatibility of these tools must be improved before they can be used in real-time flight experiments. Also, a standard set of Java-based interface tools is needed.

B.5 Materials Science

B.5.1 Technologies

Following are brief descriptions of the technologies listed in section 3.5.1. Items marked with an asterisk were developed under the ATD Program.

3.5.1.1 Coupled Growth in Hypermonotectics

The objective of this investigation is to gain an improved understanding of solidification processes in immiscible alloy systems. A portion of this study involves the development of experiment techniques that will permit steady-state coupled growth of hypermonotectic composition samples to produce aligned microstructures. A parallel effort is under way to develop a model for the coupled growth process in monotectic systems.

This analysis starts with the basic equations for diffusion controlled growth and avoids many of the simplifying assumptions often utilized in similar analyses. Experiment results will be compared to predictions from the model and utilized to improve the model. In order to permit steady-state coupled growth in hypermonotectic samples, low gravity is required. Progress to date includes the following. An ampoule assembly, using aluminum nitride (AlN) has been designed. The ampoule uses a piston and spring to accommodate contraction and shrinkage; a carbon spring was successfully used to maintain a consistent spring constant up to 1,260 °C. A vacuum ampoule loading and sealing technique has been developed which minimizes residual gas entrapment. Major advances have also been made in the models and associated analyses. Understanding the coupled growth process in immiscible alloys may improve applications such as superconductors, magnetic materials, catalysts, and electrical contacts.

3.5.1.2 Effects on Nucleation by Containerless Processing

This technology is intended to elucidate the nucleation of solids from their melts and also to assess whether ground-based methods are equally useful for containerless processing of bulk samples of pure metals. Ground methods are drop tube processing, electromagnetic levitation, and electrostatic levitation. Technique-specific factors that

influence nucleation behavior are being sought. Statistical analyses have been conducted to compare experimental results with the classical Nucleation Theory, to determine the sensitivity of the calculated results to temperature measurement error and to interpret the influence of various processing parameters on the success of achieving higher undercoolings. With deep undercooling, a unique condition for microstructural development and control exists. This condition may be utilized to improve material properties.

3.5.1.3 Alloy Undercooling Experiments in Microgravity Environment

Experiments were conducted on IML-2 to perform solidification undercooling of binary alloys. Results were compared with ground-based results, and the effects of microgravity were assessed. A complete understanding of solidification kinetics of undercooled melts is sought, including: primary dendrite tip velocities; rapid thickening of primary and secondary arms during recalcence; ripening, remelting, and solute redistribution; dendrite fragmentation and grain refinement; primary phase solidification and ripening; and eutectic solidification with concurrent primary phase ripening.

3.5.1.4 Thermophysical Properties of Metallic Glasses and Undercooled Alloys

Non-contact calorimetric methods have been developed to investigate the specific heat and thermal conductivity of undercooled alloy melts, both in the liquid and undercooled region. These quantities will contribute to the development advanced processing technologies for existing and future materials. The specific materials chosen for study are the parent compounds for a new class of bulk metallic glasses. These materials will revolutionize metallic processing technologies. With their novel, superior properties, they can be engineered to be more ductile, slipper, harder, lighter, and more corrosion resistant. Techniques for analyzing flight data are under development, and reflight samples are being identified.

3.5.1.5

Orbital Processing of High-Quality Cadmium Telluride

The modified seeded Bridgman-Stockbarger technique was utilized in the Crystal Growth Furnace (CGF) to grow cadmium zinc telluride (CdZnTe) crystals in microgravity. The reduction of buoyancy convection increased chemical homogeneity and the lack of hydrostatic pressure enabled a significant reduction in defect density. Improved crystals can be made for use in the fabrication of medium- and long-wavelength IR sensors and beta- and gamma-ray nuclear detectors. Experimental results showed consistency with high-fidelity thermal and thermo-mechanical stress models.

3.5.1.6

Growth of Solid Solution Single Crystals

Melt, Te-solvent growth methods, and growth in magnetic fields methods are under development. The Advanced Automated Directional Solidification Furnace (AADSF) was used to grow a 16-cm long $\text{Hg}_{0.8}\text{Cd}_{0.2}\text{Te}$ alloy crystal. Orbital and residual accelerations effects were correlated to various crystal features and alloy compositional changes. Application of magnetic fields was shown to reduce radial compositional variations in the crystals, agreeing well with theoretical predictions. The electrical and optical properties of these materials makes them important to a wide range of technological applications in the areas of sensors and lasers, with applications to optical computing, communications, and national defense

3.5.1.7

Crystal Growth of II-IV Semiconducting Alloys by Directional Solidification

A new seeded method has been developed for the growth of mercury zinc telluride (HgZnTe) crystal ingots from pseudobinary melts. Bridgman-Stockbarger directional solidification technique was used in the microgravity CGF. Supporting normal gravity studies were conducted in the Ground Control Experiments Laboratory (GCEL). A vapor transport method was developed to grow 2-cm zinc telluride (ZnTe) seed crystals in fused silicon ampoules. The effect of reduced gravity on the crystal growth of HgZnTe and mercury zinc selenide (HgZnSe) are sought, especially on the fluid dynamic and compositional redistribution phenomena during the crystal growth of solid solution semiconducting alloys which have large separation between the liquidus

and solidus of the constitutional phase diagrams. More accurate material properties are sought. These materials are of importance to electronics and IR detectors.

3.5.1.8

The Study of Dopant Segregation Behavior During the Growth of GaAs in Microgravity

Sample/ampoule design configuration was completed for use in the CGF to fabricate and process selenium-doped gallium arsenide (GaAs) crystals. The crystals will be characterized with optical, electrical and chemical properties. Results will be compared with theoretical predictions.

3.5.1.9

Temperature Dependence of Diffusivities in Liquid Metals

Several technologies were developed to facilitate studies of diffusion mechanisms in liquid metals and alloys over a wide range of temperatures, including those proximate to the materials' melting points. Improvements to experiment design were made and numerical models established with realistic boundary conditions. An efficient technique for dynamic in situ measurements of diffusivities in melts as a function of temperature is sought.

3.5.1.10

Particle Engulfment and Pushing by Solidifying Interfaces

Techniques were developed to study the pushing and engulfment of particles by planar liquid/solid interfaces during solidification of metallic alloys. A new nondestructive technique was developed to characterize particle positioning before and after processing. The method of testing samples was validated in the Advanced Gradient Heating Furnace (AGHF) furnace in France.

3.5.1.11

Crystal Growth of ZnSe and Related Ternary Compound Semiconductors by Physical Vapor Transport

Optimized methods to grow these compounds are being sought. A novel vapor transport three-thermal-zone heater translating method will be used in either the CGF or the

AADSF. Various characterization techniques are being perfected and standardized. Analytical and theoretical methods are being developed to evaluate crystals. Mass flux was measured and compared to theoretical calculations. Horizontal and vertical growth of ZnSe, zinc selenium telluride (ZnSeTe), and zinc selenium sulfide (ZnSeS) were performed and the crystals characterized. These materials are useful for optoelectronic applications, such as high-efficiency LED's and high-temperature lasers in the blue-green region of the visible spectrum. The optical bistable properties of ZnSe make it a possible candidate material for digital optical computers.

3.5.1.12

Measurement of Viscosity and Surface Tension of Undercooled Melts

The electromagnetic levitation unit, TEMPUS, was utilized on IML-2 to measure the viscosity and surface tension of undercooled melts. A method of utilizing oscillations to study surface tension and viscosity were developed. Viscosity is indicated by the decay in oscillatory amplitude, and surface tension by the frequency of the oscillations. New theories and numerical models were developed to assess the unexpected enhanced viscosity observed in microgravity during the IML-2 flight. Accuracy of computational models was validated against available analytical results and ground-based experimental results.

3.5.1.13

Test of Magnetic Damping of Convective Flows in Microgravity

Experimental and numerical methods were developed to investigate the use of magnetic damping to suppress convective flows driven by gravity, vibration, or surface tension gradients. Materials to be studied are a dilute alloy (Ga-doped Ge), and three solid solutions (Ge-Si, InSb-GaSb, and Cu-Ni), with two diameters, using the Bridgman method. Diffusion controlled growth was accomplished. The accuracy of numerical methods for predicting the needed magnetic field was validated. Sample containers and demarcation techniques were developed.

***3.5.1.14**

Real-Time X-Ray Microscopy for Solidification Processing

An XTM for the in situ and real-time observation of interfacial processes in metallic systems during freezing or

solid-solid transformation is being developed. The XTM will provide a resolution for specimen features of 10–100 μm , at rates of 0.1 to 20 $\mu\text{m}/\text{sec}$; at temperatures of 1,100 $^{\circ}\text{C}$ with gradients up to 50 C/cm ; contrast sensitivities sufficient to detect 2–5 percent difference in absorbance; with one, two, or four exposure times of a few seconds; and permit recording of stereo pairs for depth information. Physical processes that play a role in the determination of technologically important properties of solids can be studied in opaque materials, especially metallic. Specifically, studies of interfacial morphologies and particle-interface interactions can be observed.

***3.5.1.15**

Advanced Heat Pipe Technology for Furnace Element Design

The capabilities of heat pipe technology are being used as isothermal liners. Goals are to fabricate liners to operate at up to 1,500 $^{\circ}\text{C}$, to determine the feasibility and establish the protocol for the incorporation of liquid metal heat pipes as furnace liners in a crew-tended environment in space, and to develop a furnace with no moving parts that can solidify or cool materials with a high degree of control. The performance of the device, the Moving Gradient Heat Pipe Furnace (MGHPF), will be extensively characterized. The first three heat pipes were designed and fabricated. The MGHPF was installed at MSFC and initial testing begun. Crystals of several materials were grown.

***3.5.1.16**

Ceramic Cartridges via Sintering and Vacuum Plasma

A manufacturing process is under development for containment cartridges used in high-temperature (1,200–2,000 $^{\circ}\text{C}$) crystal growth furnaces. A thermal spray process will be used to build up refractory metals and ceramics into a containment cartridge for high-temperature, single-crystal semiconductor growth experiments. These plasma spray-formed materials will be evaluated for mechanical properties, density, microstructure, and resistance to liquid metal attack. Forming techniques and the resultant mechanical and metallurgical properties will be identified. Materials and processes will be characterized and evaluated.

B.5.2

New Technology Requirements

Following is a brief description of the new technology requirement listed in section 3.5.2.

3.5.2.1

Development of a Test Facility for Seebeck Solidification Experiments

A test facility is needed to measure the Seebeck potential of solidifying interfaces. Electronics for measurements and a furnace system for low-temperature alloy solidification (up to 500 °C) are needed. The system is needed to facilitate practical solutions to the technical problems of electrical contact, noise, and sensitivity inherent in Seebeck potential

measurements. Materials for the Study of Interesting Phenomena on Orbit (MEPHISTO) furnace flight experience has shown that Seebeck measurements have profound sensitivity to gravity perturbations due to space shuttle maneuvers. This facility is needed to support investigations for the Space Station Furnace Facility modules, whose science requirements indicate measurement of solidification interface temperatures in microgravity. These data are critical experimental parameters for verifying empirical values used in mathematical models. These models are crucial in evaluating competing theories that explain the effect of gravity on solidification of alloy solid liquid interfaces. Also, this capability for measuring Seebeck potential, if used in conjunction with the STM under ATD development to observe interfacial shape and composition, might yield the data to validate Seebeck theories applicable to more complex systems.

B.6 ***Multidiscipline Technology***

B.6.1 ***Technology***

Following is a brief description of the technology listed in section 3.6.1. This technology was developed under the ATD Program.

3.6.1.1 ***Free-Float Trajectory Management***

An instrument is being designed which takes information from accelerometers and aircraft control inputs (e.g., wind speed, altitude, and control surface deflections) and displays it to pilots in such a graphic and immediate manner that the pilots can use the display to guide the craft to attain extended periods of free-float. The pilot sees a computer generated package positioned inside the fuselage and responds by controlling the aircraft to keep the package freely floating.

B.6.2 ***New Technology Requirement***

Following is a brief description of the new technology requirement listed in section 3.6.2.

3.6.2.1 ***Miniature Microscope***

Both PCG and colloid physics experiments could benefit from a microscope small enough to add to experiment apparatus. This would allow direct observation of ordering in colloids, supplementing laser light scattering and Bragg scattering techniques. If small enough, several such microscopes could be placed on adjacent PCG cells, permitting observation, while not inducing g-jitter.

