

6120/CR-97- 206353

FINAL  
11-44-CR

01/14/97



# FLORIDA POWER AFFILIATES

## PV Array Driven Adjustable Speed Drive For A Lunar Base Heat Pump

December 31, 1995

Final Report  
(Phase I)

Prepared by

**Alexander Domijan, Jr.**                      **Tariq Aslam Buchh**  
*Associate Professor and Director*        *Graduate Research Associate*  
**Florida Power Affiliates and Power Electronics Consortium**

Department of Electrical and Computer Engineering  
University of Florida  
332 Benton Hall, P.O. Box 116200  
Gainesville, Florida 32611  
Tel (352) 392-0290, Fax (352) 392 8671

Prepared for

**National Aeronautics and Space Administration  
(NASA)**

submitted to

**Mr. Michael Ewert**  
Mail Code EC-7,B7, Room 127  
NASA - Johnson Space Center  
2101 NASA Road 1  
Houston, TX 77058  
Tel # (713) 483-9134; Fax# (713) 483-9167

# TABLE OF CONTENTS

## ABSTARCT

### 1. AC MOTOR DRIVES

#### Introduction

- 1.1. Induction Motor Drive.
- 1.2. Permanent Magnet Brushless dc Motor Drive.
- 1.3. Switched Reluctance Motor Drive.

### 2. SUITABILITY FOR AEROSPACE APPLICATION

#### Introduction

- 2.1. Case I. Heat Pump Powered by the System Power.
- 2.2. Case II. Heat Pump Powered by an Independent PV Array.
- 2.3. Case UF- I. Heat Pump Powered from an Independent PV Array with enhanced reliability.
- 2.4. Requirements of the Aerospace Application.
- 2.5. Comparison of the three ac Drive Systems.

### 3. INDUCTION MOTOR DRIVE FED FROM A PV ENERGY SOURCE - Application and Performance.

### 4. CONTROL OF INDUCTION MACHINES.

- 4.1. Linear Feedback Methods.
- 4.2. Nonlinear Control Technique.
- 4.3. Vector Control Technique.
- 4.4. Fuzzy Logic Control.
- 4.5. Fuzzy Logic Control for AC Motor Drives.
- 4.6. Conclusion.

### 5. POWER CIRCUIT HARDWARE.

#### Introduction.

- 5.1. Power Semiconductor Devices.
  - 5.1.1. Thyristor.
  - 5.1.2. Gate Turn Off Thyristor.
  - 5.1.3. Power MOSFET.
  - 5.1.4. Insulated Gate Bipolar Transistor.
- 5.2. Conclusion.

### 6. CONCLUSION.

## REFERENCES

## LIST OF FIGURES

Number	Title	Page
Figure 1.	Three Phase Bridge Converter.	4
Figure 2.	Synthesis of Voltage Waves in Bridge Converters.	5
Figure 3.	Sinusoidal Pulse Width Modulation.	6
Figure 4.	Simplified Diagram of the SRM Drive.	9
Figure 5.	Lunar Base Power and Thermal System- Case I - Heat Pump Powered by System Power	13
Figure 6.	Case II - Stand Alone PV Array for the Heat Pump.	14
Figure 7.	Case UF I - Enhanced Reliability Independent PV Array Driven Heat Pump.	15
Figure 8.	Temperature Sensing Circuit for use in Case UF I.	16
Figure 9.	VSI-PWM Based IM-ASD Set.	21
Figure 10.	A 5 hp IM Current at Full-Load Without ASD.	21
Figure 11.	A 5 hp IM Current at No- Load Without ASD.	22
Figure 12.	FFT Analysis of IM Current at No-Load.	22
Figure 13.	Laboratory Acquired IM Waveforms with ASD.	23
Figure 14.	IM Waveforms Obtained Using IM-ASD Computer Simulations.	23
Figure 15.	IM Current Obtained by Simulating PWM IM-ASD System.	24
Figure 16.	FFT Analysis of IM Current of Figure 15.	24
Figure 17.	Closed Loop Volts/Hertz Speed Control.	25
Figure 18.	Basic Configuration of Fuzzy Logic Controller.	28
Figure 19.	Equivalent Circuit of an IGBT.	32

## ABSTRACT

A study of various aspects of Adjustable Speed Drives (ASD) is presented. A summary of the relative merits of different ASD systems presently in vogue is discussed. The advantages of using microcomputer based ASDs is now widely understood and accepted. Of the three most popular drive systems, namely the Induction Motor Drive, Switched Reluctance Motor Drive and Brushless DC Motor Drive, any one may be chosen. The choice would depend on the nature of the application and its requirements. The suitability of the above mentioned drive systems for a photovoltaic array driven ASD for an aerospace application are discussed. The discussion is based on the experience of the authors, various researchers and industry. In chapter 2 a PV array power supply scheme has been proposed, this scheme will have an enhanced reliability in addition to the other known advantages of the case where a stand alone PV array is feeding the heat pump. In chapter 3 the results of computer simulation of PV array driven induction motor drive system have been included. A discussion on these preliminary simulation results have also been included in this chapter. Chapter 4 includes a brief discussion on various control techniques for three phase induction motors. A discussion on different power devices and their various performance characteristics is given in chapter 5.

## 1. AC MOTOR DRIVES

This report contains a total of five sections. In section one a brief review of the three ac motor drives is presented. A general understanding about the operation of each drive is presented with reference to their advantages and disadvantages. Section two discusses the requirements of the drive system suitable for aerospace applications. In light of these requirements, in this section a qualitative and quantitative comparison between the performance of induction motor, brushless dc motor and switched reluctance drive systems is presented. Based on this, the selection of an induction motor drive system for aerospace solar photovoltaic heat pumps is justified. Section three provides a brief introduction for photovoltaic driven induction motor-heat pump systems. The classical, linear and nonlinear, as well as the newly emerging control techniques for ac motor drives are summarized in section four. The emphasis here is given to the new methodology of fuzzy logic control systems which provide an excellent approach for controlling ac drives. Details about the power circuit hardware are give in section five. In this section the characteristics and performance of various power semiconductor devices are discussed

### Introduction

The history of solid state ac ASD dates back to 1960 's[1]. The technology has been enhanced and developed by employing improved devices, circuits, control theory and signal processing[2]. Further with the advent of microelectronics, the ac drive system became more flexible and reliable[3]. The minimization and simplification of the electronic hardware was readily achieved[4].

### Review of AC Motor Drives

A review of three most commonly used ac motor drives is presented here. These are:

- 1.1. Induction Motor Drive.
- 1.2. Brushless DC Motor Drive.
- 1.3.. Switched Reluctance Motor Drive.

#### *1.1. Induction Motor Drive:*

Induction machines in general and the squirrel cage induction motor in particular are presently the main work horse for fixed and variable speed drives in the industry. The squirrel cage induction motor is particularly simple in its construction. As compared to its DC counter parts it is generally more efficient, robust and reliable. Induction machines are low cost machines and require minimal maintenance. For the same power rating the induction motor is lighter in weight and smaller in size as compared to any other type of machine. They require control of frequency, voltage and current for variable speed applications. The power converters, inverters and ac voltage controllers, can control the frequency, voltage and/or current to meet the drive requirements. Although the induction motor is simple in its construction, the cost of the converter is high. The control of an induction motor is more complex and requires intricate signal

processing. The complexity increases when a higher drive performance is demanded. This problem has been greatly solved by the advent of very fast and powerful microcomputers.

The complexity of control is mainly because the machine dynamics (d-q model) are described by higher order nonlinear multivariable state space equations. This problem can be overcome by linearizing the system about a particular point of operation and then applying conventional linear feedback and control techniques. The system can be defined for a certain set of system and control parameters. The analysis can be run by using any one of the available simulation programs like PSPICE, Saber, etc. Despite these minor drawbacks the advantages of the induction motor drive far outweigh its disadvantages.

In adjustable speed a.c. drive systems, a static power converter constitutes an interface between the primary power supply and the motor. The converter may have a dc or ac input and the output may be at variable - voltage - constant - frequency, constant - voltage - variable - frequency, or variable - voltage - variable - frequency. The converter consists of a matrix of power semiconductor switching devices which may be thyristors, GTOs, Power MOSFETs or IGBTs etc. Since the converters are static i.e. no dynamics are involved in the converter circuit, the input and the output power match at any instant. The output waveform may be constructed from input waves and the characteristic switching functions. The converter operation and its mode of control severely affects the machine performance; the machine parameters similarly affect the converter performance.

Several practical Induction Motor drive systems are:

A. *AC voltage controller.*

This is a simple and economic method of speed control of cage induction motors. The controller consists of an array of bidirectional controlled power devices e.g. TRIACS or anti-parallel combinations of unidirectional power electronic devices e.g. SCRs, GTOs, IGBTs etc. AC voltage controllers generate variable voltage at input supply frequency by symmetrically phase controlling the trigger angles.

B. *DC link current source inverter.*

Here a phase controlled rectifier generates variable dc voltage which is converted to a current source by connecting a large inductor in series. A Current Source Inverter (CSI) also needs an extra converter stage to control the current. The output current is maintained constant irrespective of load on the inverter and the output voltage is forced to change. It requires an output filter to suppress the output voltage spikes which are produced when current transfers from one pair of switches to another. The dynamic response is slow as it is current controlled.

C. *DC link voltage source inverter.*

The input to the voltage source inverter (VSI) is a stiff dc source. The dc source may be a fuel cell, a battery, the output of a controlled rectifier or a photovoltaic(PV) array. In a VSI the inverter

converts the input dc voltage into an ac supply. This is achieved by controlling the switching of the power electronic devices in the converter power circuit.

The dc link Voltage Source Inverters (VSI) are classified into two types:

- a) Square Wave Inverter.
- b) Pulse Width Modulated (PWM) Inverter.

a) The Fig. 1. shows the conventional power circuit for the square wave inverter. The required additional circuitry for protection is omitted for simplicity. The inverter consists of three half-bridge unit where the upper and lower power electronic devices of each unit are switched ON and OFF alternately for  $180^\circ$  intervals. The three half bridges are shifted by  $120^\circ$ . The waveform synthesis of three phase waves is shown in Fig. 2.

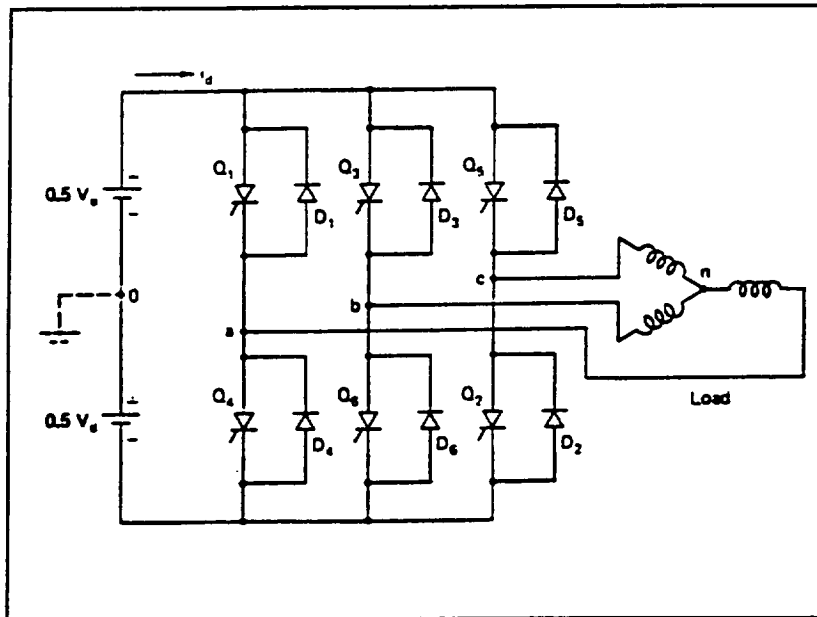

**Figure 1. Three Phase Bridge Inverter.**

b) The power circuit of a PWM inverter is similar to the square wave inverter. In the PWM inverter instead of switching the upper and lower devices alternately for  $180^\circ$ , each device is turned ON and OFF a number of times during each  $180^\circ$  period. The output voltage of the inverter is varied by changing the pulse width of each half-cycle of the inverter output voltage. To explain how the PWM method used in ac drives works, a sinusoidal PWM technique is illustrated. In the sinusoidal PWM method a triangular carrier wave of frequency  $f_c$  and a modulating wave of frequency  $f_m$  (the same frequency as that of the inverter output) are used to modulate the pole voltage. The Fig. 3. shows how a single phase PWM wave is generated.

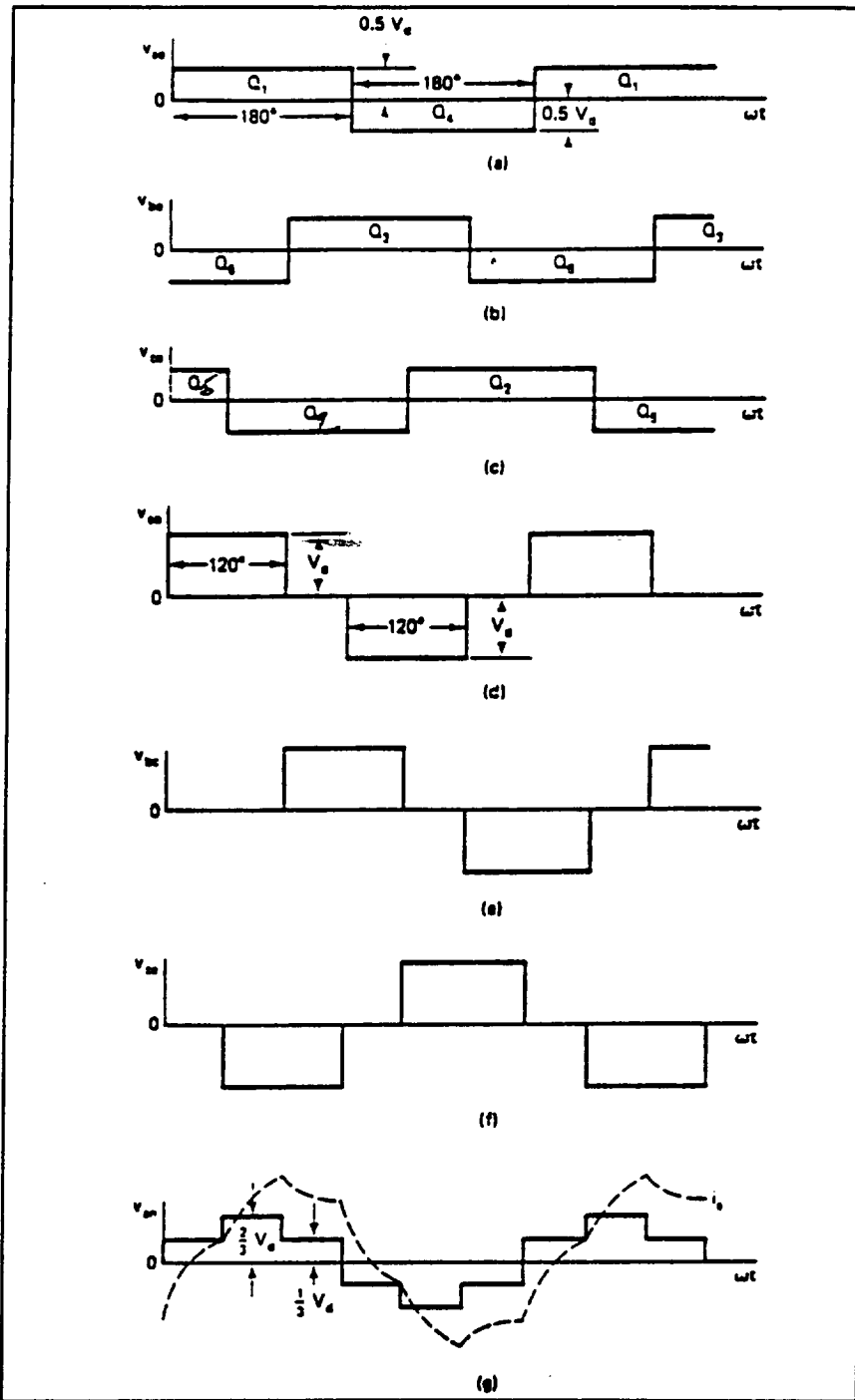

Figure 2. Synthesis of Voltage Waves in Bridge Inverters.



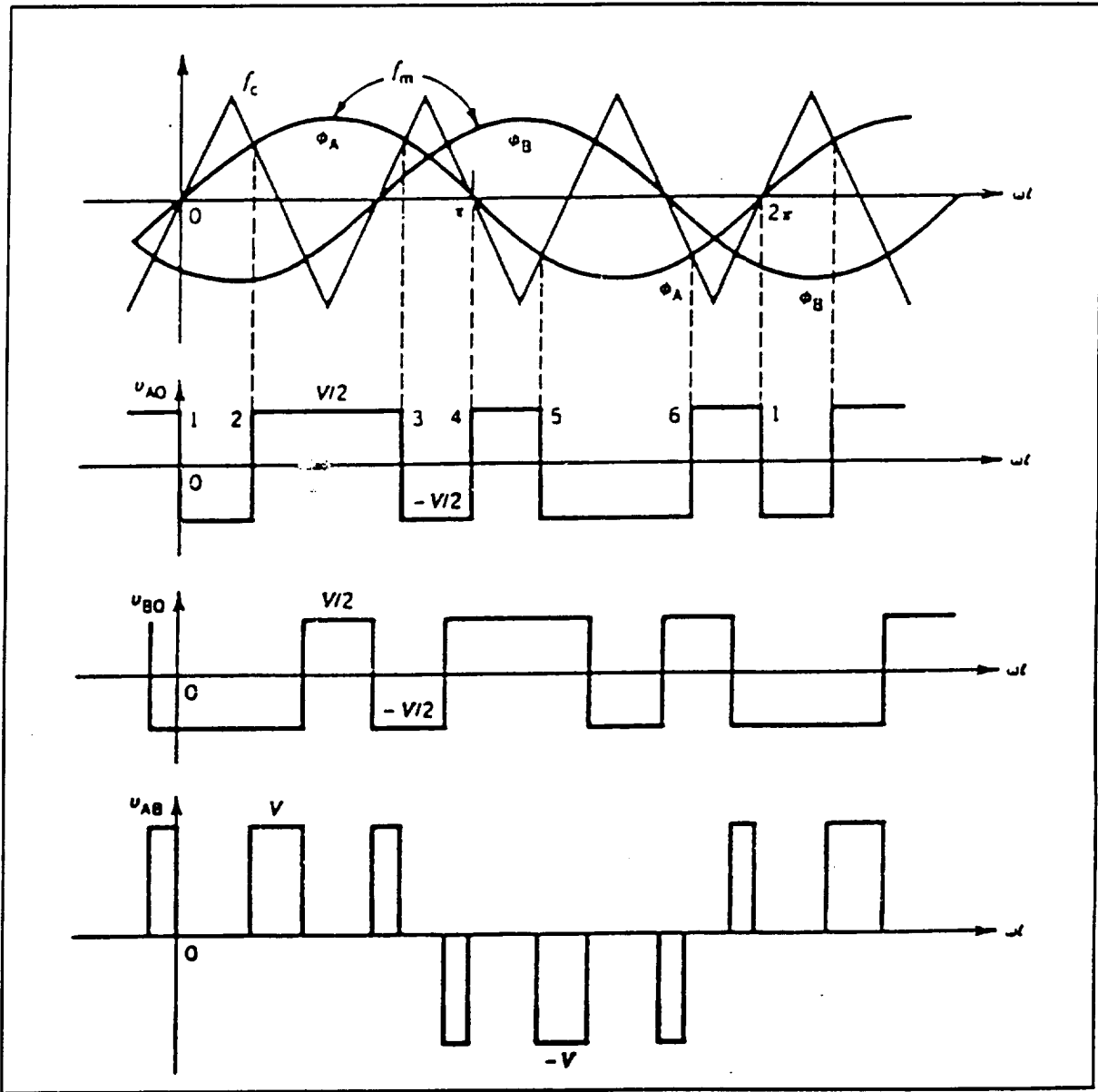

Figure 3. Sinusoidal Pulse Width Modulation

## *1.2. Permanent Magnet Brushless dc Motor Drive:*

The permanent magnet synchronous machine or the brushless DC machine is a class of synchronous machine. These motors have attracted a great deal of attention from industry. They have found application in the low to medium power ranges. The BDCM are classified into two classes viz sinusoidally excited and trapezoidally excited. The two only differ in their motion control characteristics.

In the permanent magnet machines the field excitation is provided by a set of permanent magnets. The magnets are placed on the rotor while the armature is fed from a three phase ac supply. It has rotor position sensors the outputs from which are decoded to provide basic switching control signals for the inverter. The position sensors, such as resolvers and absolute encoders, increase the cost and size of the motor and restrict its application [5]. As opposed to a conventional DC machine, the BDCM has no brushes or even slip rings. This makes the machine structure more simple and reliable. Because of the use of permanent magnets, the field excitation is currentless hence lossless, thus with a higher efficiency. This advantage is more significant in small and medium power rating motors only, since in large rating motors the field loss is just a small percentage of the total motor losses. Due to the non availability of high energy magnets at an economical price the BDCM is more expensive than a conventional machine but has a higher efficiency. The size also is reduced with the use of a high energy magnet. The armature windings in a BDCM are part of the stator. These windings are similar to those in a polyphase AC motor and the most orthodox and efficient motor has a set of three phase windings and is operated in bipolar excitation. BDCM are different from AC synchronous motors in that the former incorporates some means to detect the rotor position to produce signals to control the electronic switches. An advantage of BDCM is due to the fact that the armature is located on the stator. This increases the surface area, hence an improved heat transfer. Also more copper area causes a reduction in copper losses. The aforementioned advantages i.e. no rotating field windings, armature located on the stator and no commutator and slip rings, are important for applications like air and spacecraft actuators, electric vehicle drives, robotics and machine tools, etc.

The drawback of BDCM drive systems is a complex control strategy and complicated inverter topology. As compared to the Induction Motor Drive, the BDCM is bigger in size. The power converter size is also large. The overload capacity is low and the cost high, as compared to the Induction Motor Drive system. The most serious drawback is the phenomenon known as the irreversible demagnetization of the permanent magnets[6]. This phenomenon is explained in the following paragraph.

In the normal range of operating temperature, as the temperature of the machine rises, the residual flux density and the intrinsic coercivity of the magnet comes down. This process is a reversible process but only if the increase in temperature is not beyond a certain critical limit. If the machine gets heated up beyond the critical temperature, the magnets get permanently demagnetized. The critical temperature of the magnets is a function of the type of magnet and the operating load line of the magnet. The effect of a rise in the operating temperature, is a decrease in the motor efficiency. Since as the temperature increases the resistance of the armature increases, the increase in temperature also causes the motor back emf to fall. Both of these factors contribute to a reduced motor efficiency[7].

In the BDCM the average torque falls as the rotor speed is increased towards the base speed and the motor which meets the specified average torque for a given application will frequently be found to have insufficient torque at higher speeds[8]. In a normal DC motor the machine can be operated above the base speed by reducing the field excitation. Since in a BDCM the field excitation is provided by permanent magnets this is not directly possible. The BDCM can be operated above the base speed by using the methods of indirect field weakening control or extended conduction angle control. Although these methods allow the maximization of torque at high speeds, they are not simple and have certain limitations[9]. Apart from increasing the conduction losses, these methods produce a risk of permanent demagnetization of the field magnets. The power converter capability imposes additional limiting factors to the flux weakening operation and hence, to the speed range of a permanent magnet machine[10].

### *1.3. Switched Reluctance Motor Drive:*

Switched Reluctance Machines (SRM) have been known for a long time. These motors are a class of variable reluctance stepping motors designed for efficient energy conversion. The SRM has a concentrated stator winding, but there is no magnet or winding on the rotor. Hence the rotor is brushless. The SRM is doubly salient with an unequal number of rotor and stator poles. The machine is simple and economical. A reluctance motor is an electric motor in which the torque is produced by the tendency of its moveable part to move to a position where the inductance of the excited winding is maximized. In other words the rotor poles tend to align with the poles of the excited stator phase. The stator winding comprises a set of coils, each of which is wound on a pole. The SRM has a simple construction.

Fig. 4. shows the simplified diagram of a SRM. For motoring action, a stator phase must be excited when a pair of opposite rotor poles is approaching its poles and must be turned off before rotor and stator poles actually come into alignment. Continuous rotation of the rotor is obtained by exciting the stator phases sequentially; the rotor stepping around in a direction opposite to that of stator phase excitation [11].

The SRM operates in a series of strokes or transients and does not have a steady-state in which all its state variables are constant. The jerky motion of the field does not allow smooth torque and good operation, particularly in the low speed operation range. The flux and current of the SRM appear to be constant in no reference frame. This is quite unlike the Induction Motor and BDCM, where system parameters can be linearized or taken to be constant about certain operating points. The SRM is not compatible with the stators and controllers of other ac motor drives.

The phase excitation pulses of the SRM need to be properly synchronized with the rotor position for effective control of speed, torque and torque pulsations; therefore, the rotor position information is essential as a feedback for the control section. A shaft position transducer like a high precision encoder, is usually employed to determine the shaft position. These add to the complexity and cost of the system and makes it less reliable. In aerospace applications these discrete sensors are quite undesirable[12]. Several indirect position sensing schemes have been reported in the literature but their effectiveness and satisfactory performance in field applications has yet to be amply demonstrated, as it is still in the research stage.

The efficiency of SRM is lower than the efficiency of BDCM but as high as the Induction Motor. They are quite reliable and small in size. The motor cost is not very high when compared to the other two types of AC machines, however the maximum motor speed is very high. The converter cost is also lower than the Induction Motor Drive converter.

Among the disadvantages of the SRM drive are a high torque ripple and low overload motor capacity. The pulsating torque together with acoustic noise are serious problems. Multiple machine operation with a single converter is also not possible. Judging from these drawbacks it doesn't seem that the SRM would pose a serious threat to the Induction Motor Drive systems for the industrial applications.

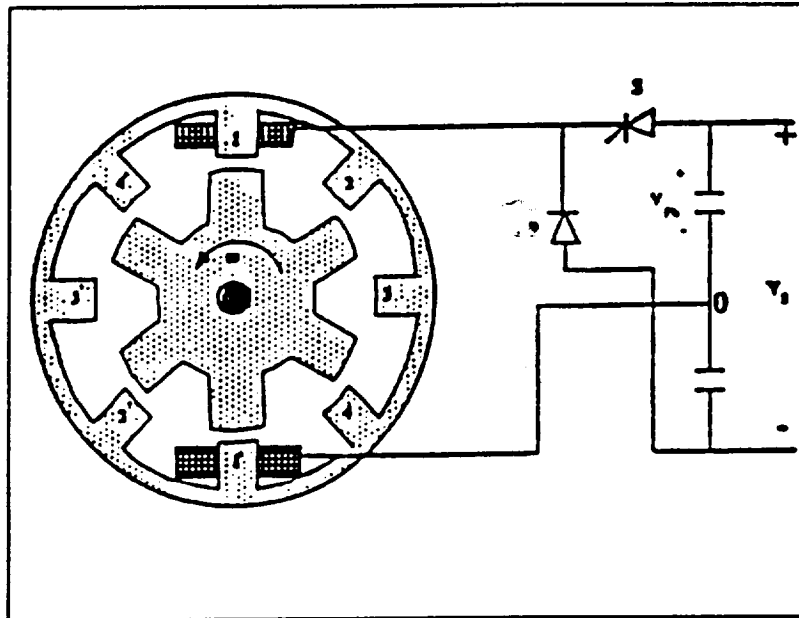

Figure 4. Simplified Diagram of the SRM Drive

## 2. SUITABILITY FOR AEROSPACE APPLICATION

### *Introduction:*

Before discussing the suitability of each of the drive systems for use in an aerospace solar photovoltaic (PV) heat pump for a lunar base, an outline of the requirements for the particular application is presented. Figures 5 & 6 show the proposed layouts of the Lunar Based Power and Thermal Systems. These figures have been provided by JSC-Houston.

In the first case (Fig 5), where the heat pump is powered by the system power, the electrical power input to the drive system is quality power. This power is fed to the converter by an SPDA through the RPCM. In this case the same PV array is feeding the drive system and the other electrical loads. The obvious advantage of this proposed case is that refined power, free from noise and fluctuations is fed to the converter. In this case the drive system may even be operated in the open loop and preset speed command can be given to the converter to make the motor run at a certain desired speed. In addition to stability problem, which is inherent in open loop systems, the other undesirable effect can be an injection of harmonics on the supply side. These harmonics can effect other sensitive loads connected to the particular SPDA.

In the second case (Fig 6), the heat pump is powered by a separate PV array, this PV array may be physically or electrically isolated from the main array. In this scheme the line side harmonics will not effect any other load connected to the electrical system and here a considerable reduction in the required rating of the power conditioning equipment and hence its mass can be affected. The PV arrays will need to be optimally designed to prevent an increase in the array size and mass which would offset the advantage of reduced power conditioning requirements. The problem with such an arrangement is that of low reliability. This is due to the absence of a backup power supply for the heat pump. The solution to this problem is discussed in section 2.3.

Section I of this report presents a general understanding of the three ac drive systems, with a brief reference to the advantages and drawbacks of each. As is obvious, the choice of the motor drive system for a particular application would depend on, first the nature of the application and second on the degree of expected performance, e.g. efficiency, harmonics (supply side and load side), reliability, economy of the system (installation and running costs) etc. The nature of application would include the environment in which the drive system has to operate, the nature of input power supply, the duration for which it has to operate, type of cooling, allowable maximum temperature rise, allowable size and weight of the system and most important the nature and requirements of the load to be driven, which would include the power, the speed and torque requirements of the load.

Each of the aforementioned criteria are important and should be considered before making the selection of the drive system. Following the normal selection and design procedure, priorities should be set and then the necessary tradeoffs between conflicting criteria done, this would enable the selection of the best drive

system keeping in view both the nature of the application and the degree of expected performance.

### *2.1 Case I. Heat Pump Powered by the System Power:*

In this case the other electrical installations in the lunar base are fed from the same PV array as the heat pump. This arrangement is shown in Fig 5. Since there are more than one (three) PV arrays connected in the ring system, the system will be reliable. Even in the case of failure of two PV arrays, the system will continue to run on the third system, although at a reduced capacity.

The drawback with this is due to the fact that Adjustable Speed Drives (ASD) tend to inject heavy harmonics into the line system. These harmonics may adversely affect the performance of other electrical and electronic equipment connected in the system. This will be very serious in particular for any precision measuring instruments, which are highly sensitive to harmonics and noise.

The other disadvantage with this case is that the drive system will receive refined quality power. This is quite unnecessary, as very high drive performance can be obtained just by feeding raw power from the PV array and operating the system in closed loop. Feeding refined power to the drive system increases the overall weight of the system. This is because more switching, isolating and power refining blocks will be required. Since the system weight is an important constraint, this arrangement would be undesirable from that point of view.

### *2.2. Case II. Heat Pump Powered from an Independent PV Array:*

In this case the heat pump will be fed from an independent PV array. The obvious advantage of this system is isolation of noise and harmonics producing elements from the noise and harmonics sensitive elements of the system. The fact that raw power will be fed to the system will decrease the hardware requirement and hence reduce the weight of the system. The disadvantage with this arrangement will be of low reliability. The problem and its proposed solution are discussed in the next section 2.3.

### *2.3. Case UF I. Heat Pump Powered from an Independent PV Array with Enhanced Reliability:*

As already stated the drawback of having an independent PV array supply power to the heat pump is the decreased reliability of the system. This is because of the absence of a backup power supply for the heat pump. In the event of a failure of the PV array supplying the heat pump, the heat from the system will not be pumped out. This will lead to an increase in the system temperature above safe limits which will eventually cause the whole system to fail. This problem of low reliability can be solved by employing the system layout as shown in the block diagram of Fig 7.

The system can be implemented by using speed and temperature sensors. The speed sensor will sense the speed of (the motor driving) the heat pump and this speed signal after some processing will be fed to a digital computer. The heat sensors will be distributed at selected points in the whole system. These signals after processing will be fed to the computer either individually or after averaging. The two signals will be used by the digital computer to determine the state of the heat pump and the condition of the overall

system. Using a predetermined logic the computer will then generate control signals to control the speed of the Adjustable Speed Drive (ASD) and/or the electronically controlled switch.

Let us consider a scenario in which the PV array supplying the heat pump fails. This will cause the heat pump to stop functioning, this condition will be detected by the speed sensor and reported to the computer. An increase in the overall system temperature, as a consequence of heat pump failure, will be detected by the temperature sensors. This condition will also be reported to the digital computer. The computer will now, sensing a failure of PV array and a consequent increase in system temperature, generate a control signal and send it out to the electronically controlled switch. The switch will be closed and the Fuel Cell will now be supplying the heat pump. In this way the heat pump will be able to operate even in the event of PV array failure. It is important to note that in this system if the heat pump fails but due to some reason the system temperature does not increase above a predetermined level, the switch will stay open.

Using the speed and temperature signals the digital computer will also be able to generate control signals for the ASD, thereby automatically controlling the heat pump speed. Fig 8. shows a primitive circuit for temperature signal processing.

# LUNAR BASE POWER AND THERMAL SYSTEMS

## Case I - Heat pump powered by system power

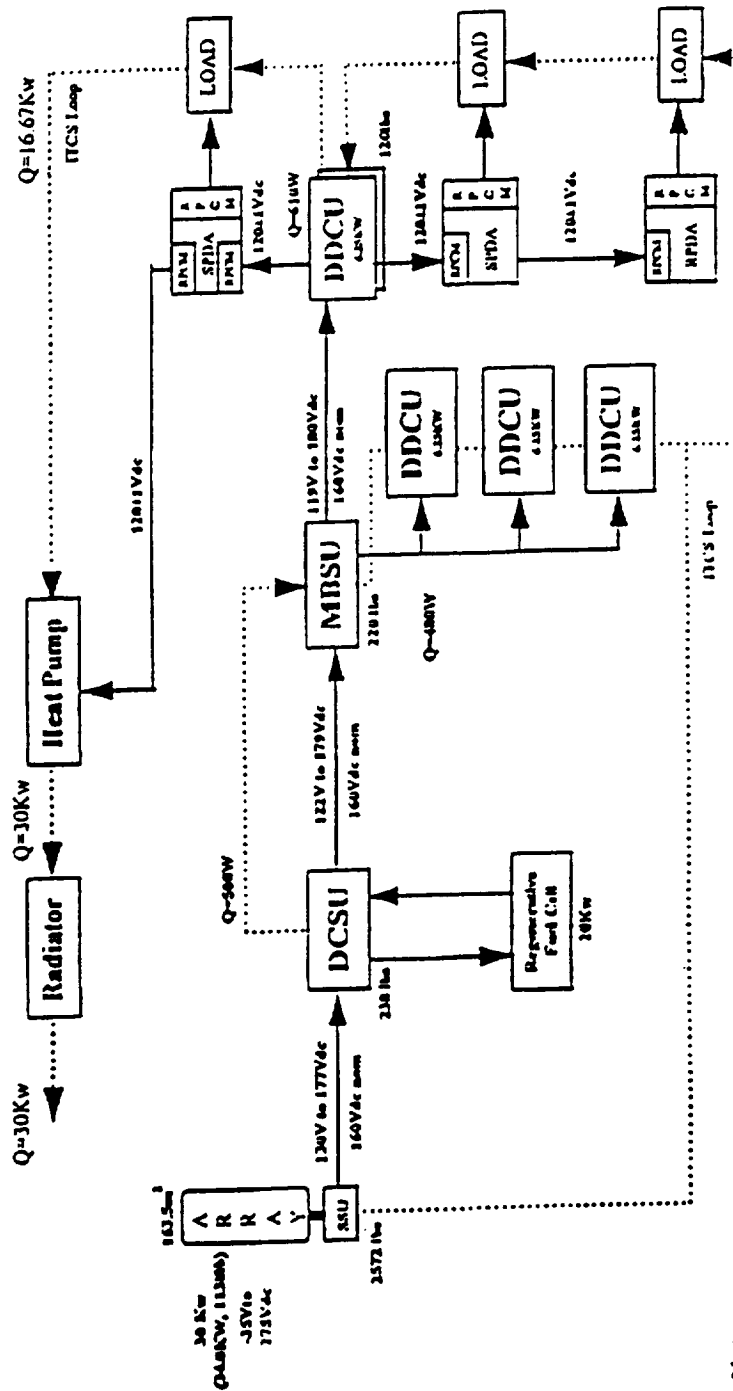

- Notes:**
1. This picture represents the power system architecture for one of three parallel strings.
  2. 34.0 KW represents the solar array size needed to deliver 30KW to the loads based on about 4KW of loss in the system. One string consists of as many as 5 DDUCU's at 6.25KW each.

**ACRONYMS:**  
 DC:SU DC SWITCHING UNIT  
 DC TO DC DC TO DC CONVERTER UNIT  
 MBSU MAIN BUS SWITCHING UNIT  
 RPDA REMOTE POWER DISTRIBUTION ASSEMBLY  
 RPCM REMOTE POWER CONTROLLER MODULE  
 SPDA SECONDARY POWER DISTRIBUTION ASSEMBLY  
 SSU SEQUENTIAL SHUNT UNIT  
 HEAT HEAT

7/19/76

Figure 5.



# LUNAR BASE POWER AND THERMAL SYSTEMS

## Case II - Stand alone PV array for the heat pump

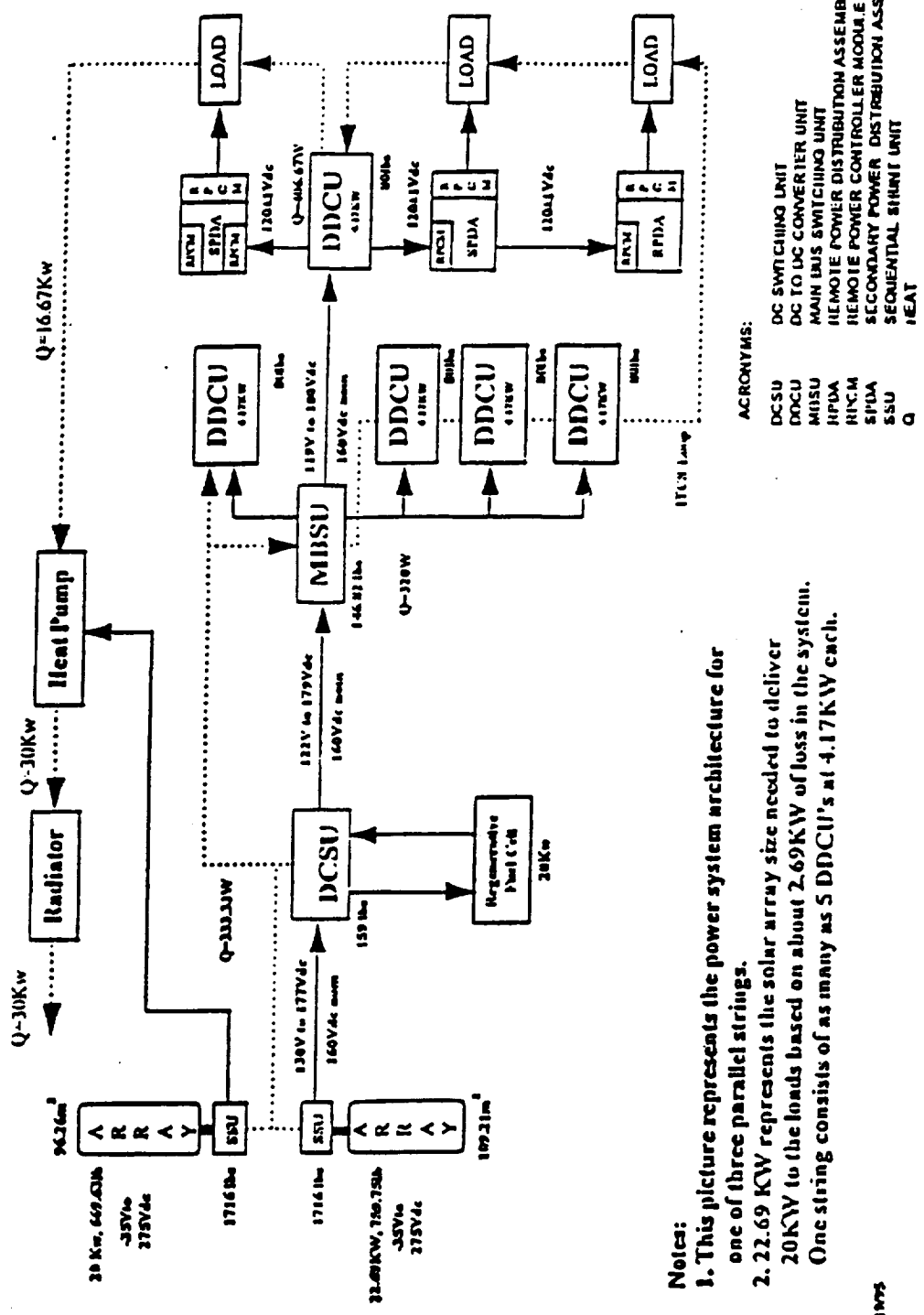

- Notes:
1. This picture represents the power system architecture for one of three parallel strings.
  2. 22.69 KW represents the solar array size needed to deliver 20KW to the loads based on about 2.69KW of loss in the system. One string consists of as many as 5 DDCU's at 4.17KW each.

ACRONYMS:

- DCSU DC SWITCHING UNIT
- DDCU DC TO DC CONVERTER UNIT
- MBSU MAIN BUS SWITCHING UNIT
- RPDA REMOTE POWER DISTRIBUTION ASSEMBLY
- SPDA SECONDARY POWER DISTRIBUTION ASSEMBLY
- SSU SEQUENTIAL POWER DISTRIBUTION ASSEMBLY
- HEAT HEAT

7/19/75

Figure 6.

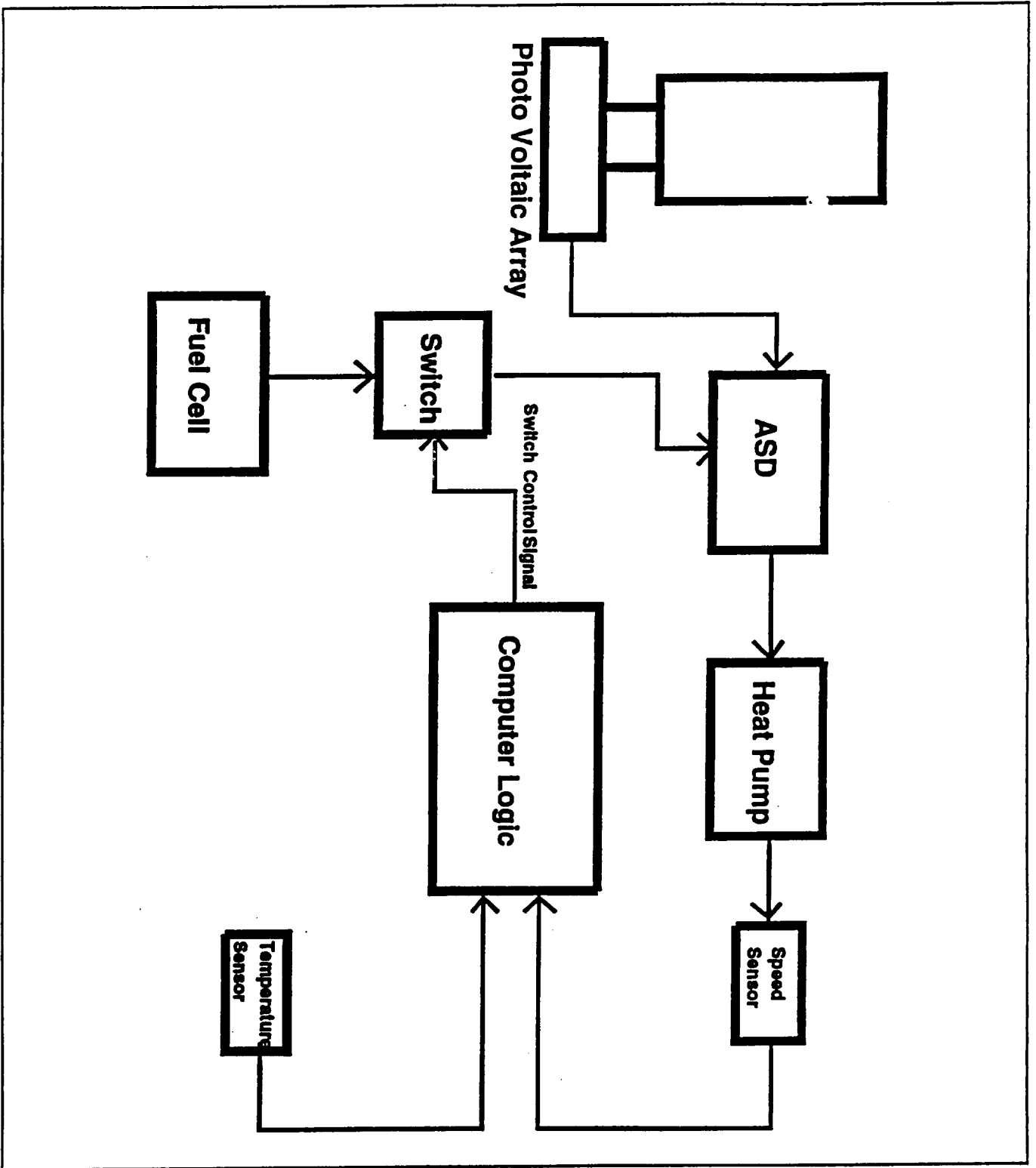

Figure 7. Case UF I; Enhanced Reliability Independent PV Array Driven Heat Pump.

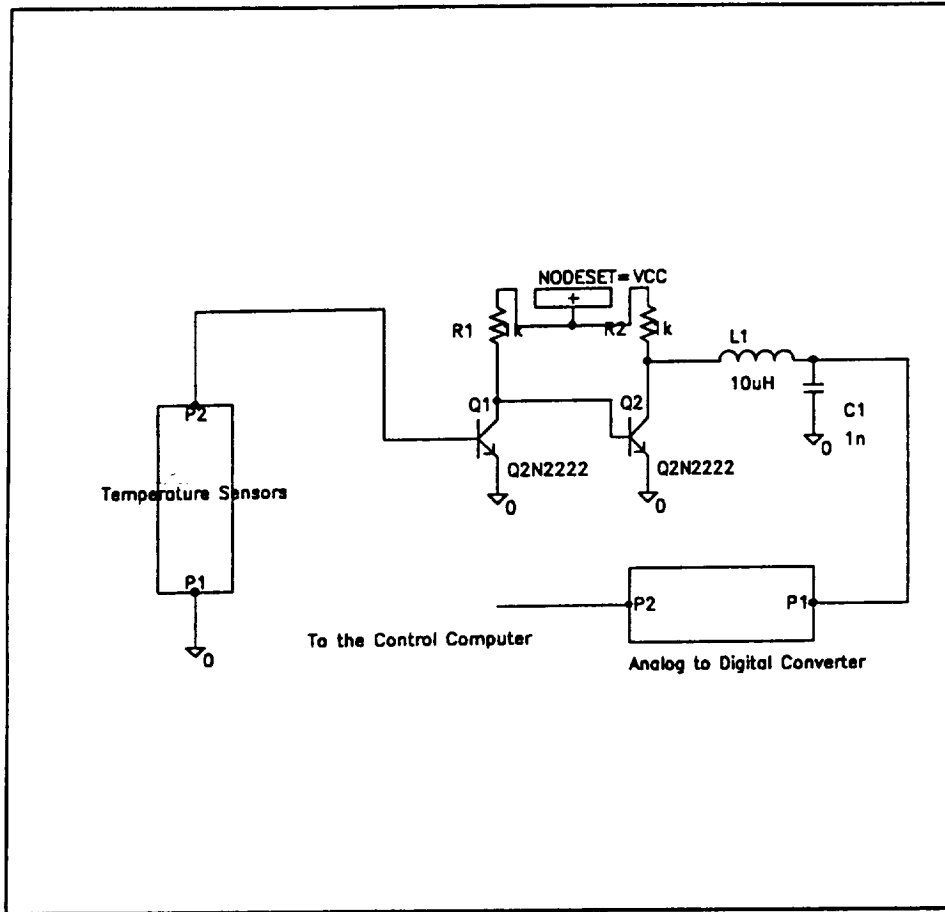

Figure 8. Temperature Sensing Circuit for Use in Case UF I.

*2.4. Requirements of the Aerospace Application:*

For the aerospace PV heat pump for a lunar base habitat, superior performance of the system is of prime importance and factors like economy become less important. Since the system is to be installed in space, weight and size become very important constraints and efforts should be made to select and develop a drive system with minimum weight and size. Reliability is another very important consideration. In this application the drive system would be required to maintain life support by cooling the equipment installed in the lunar base. The reliability of the drive system hence is important to the reliability of the whole lunar base system. The drive system should have a near zero failure rate and on top of that there should be the necessary emergency back up. A near zero failure performance can be made possible partly by using a simple and thoroughly tested hardware and software. Minimizing the hardware requirement and incorporating most of the features in the software can enhance the reliability of the system. The efficiency of the system would be a factor for the size of the PV array. The drive system is to be driven by a Photovoltaic Array. The drive system which is expected to perform well under this supply condition should be selected. The PV array driving the drive system, may also be driving other loads which may be highly sensitive to harmonics. This would necessitate a drive system which injects minimum harmonics in the supply side. The motor output torque needs to be smooth, so the load side harmonics should be minimized.

*2.5. Comparison of the three ac drive systems :*

Considering the aforementioned requirements of the Aerospace application, the relative merits and demerits of the three drive systems are presented in Table 2. For 1.5 hp rating, the size of each of the three motor types, as a function of base speed, is shown in Table 1.

This study is based on the most recent literature published in the well known journals of electric power applications. Looking at the available literature and judging from experience, the induction motor drive has an edge over the other two drive systems as far as performance, reliability and efficiency are concerned. The most serious drawback of the BDCM being that of irreversible demagnetization while the most serious drawback for the switched reluctance motor (SRM) is the presence of high torque ripple.

	HP	Syn. Speed	App.Wt(lbs)
Permanent Magnet Motor (Totally Enclosed)	1.5	3600	36
		1800	37
Switched Reluctance Motor	1.5	1800	31
Induction Motor (Totally Enclosed)	1.5	3600	32
		1800	36
		1200	110

Table 1. The weights of the three types of Reliance electric 1.5 hp motors as a function of speed. (source Reliance electric)

Induction motor Drive	Brushless DC Motor Drive	Switched Reluctance Drive
<b>Advantages</b>		
<ol style="list-style-type: none"> <li>1.Simple motor construction.</li> <li>2. High efficiency.</li> <li>3.High Reliability.</li> <li>4.Small size and weight.</li> <li>5. Rugged and robust.</li> <li>6.Very little maintenance.</li> <li>8.High overload capacity.</li> <li>9.High Maximum speed.</li> <li>10.High power ratings.</li> <li>11. Low motor cost.</li> </ol>	<ol style="list-style-type: none"> <li>1.Simple motor structure.</li> <li>2.High motor efficiency</li> <li>3.Moderate reliability.</li> <li>4.Small motor size and weight.</li> <li>6.Low maintenance cost.</li> <li>7.Efficient motor cooling.</li> </ol>	<ol style="list-style-type: none"> <li>1.Simple motor construction.</li> <li>2.High motor efficiency.</li> <li>3.High reliability.</li> <li>4.Small motor size and weight.</li> <li>9.Very high maximum motor speed.</li> <li>11.Low motor cost.</li> </ol>
<b>Drawbacks</b>		
<ol style="list-style-type: none"> <li>1. High converter cost.</li> <li>2. Complex control.</li> </ol>	<ol style="list-style-type: none"> <li>1.High converter cost.</li> <li>2.Complex control.</li> <li>3.Moderate overload capacity.</li> <li>4.Not very high maximum speed.</li> <li>5.High motor cost.</li> <li>6.Irreversible demagnetization.</li> </ol>	<ol style="list-style-type: none"> <li>1.High converter cost.</li> <li>2.Complex Control.</li> <li>3.Moderate overload capacity.</li> <li>7. A converter for each machine.</li> <li>8. Very high torque ripple.</li> <li>9.Acoustic noise problem.</li> </ol>

**Table 2. Comparative evaluation of the three drive systems, based on literature survey**

### **3. INDUCTION MOTOR DRIVE FED FROM A PV ENERGY SOURCE - Application and Performance**

Solar energy has proven to be an economical source of energy in many applications. One application area where photovoltaic energy has been established is aerospace applications. The attractiveness of using the photovoltaic energy source with machine drives is enhanced by increased reliability and reduced cost of photovoltaic cells. An experimental and operational pumping scheme exists which is driven by voltage-source inverter fed induction motors connected to the photovoltaic sources through converters. This scheme provides efficiency improvement as well as diversity of control strategies. The essential elements of the PV driven motor pump system are a PV array, a power conditioner circuit, an inverter and an induction motor driven pump. The input power required by the motor depends on the load, excitation voltage and frequency. Generally, in variable-speed drives the input voltage to supply line frequency (v/f) ratio is kept constant so that the motor can deliver a constant torque. However, in the case of this pump load, a constant torque output from the motor is not required. Therefore it is worthwhile to find the voltage-frequency relationship for the motor control, which minimizes the motor losses. More over, in order to achieve maximum adjustable speed performance the induction motor can be designed using a square laminated frame replacing the typical cast iron frame. This approach of design results in the following advantages:

1. Larger horsepower ratings in smaller frame sizes than NEMA cast iron without compromise in performance or motor life.
2. 20:1 constant torque range below base speed and 2:1 constant horse power above base speed are standard on TEAO ( Totally Enclosed Air Over-Blower Cooled) and TENV (Totally Enclosed Non-Ventilated) enclosures.
3. Motor feet located on cast iron brackets provide a rigid, vibration resistant mechanical assembly with maximum bearing support to improve structural dynamics at low and high speeds.
4. Machined mounting surfaces make it easy to mount feedback devices.
5. Quiet operation on variable frequency power due to constant speed blower and laminated construction.

Such kinds of motors have been successfully applied on many demanding applications: paper machines, machine tools, extruders, and vector controlled products. In fact these motors provide the ideal drive solution for the toughest industrial variable speed requirements.

In the case of voltage source Inverter fed induction motor, the motor characteristics can be optimized to reduce the peak currents from the inverter as well as to minimize the motor losses. Also to ensure successful operation on inverter waveshapes, including steep voltage wavefronts the insulation system should be carefully designed.

Computer simulations provide a powerful tool for a better understanding and accurate analysis of power electronic circuits including ASDs. To get an idea of the performance of an induction motor drive, computer simulations using SABER were run. The PV array was modelled as a current controlled voltage source. These simulations were run to get a better insight into the operation of induction motor drives, the

simulation and the analysis is of a preliminary nature rather than detailed and extensive. Some of the simulation results are included in this chapter.

The 5 hp induction motor and its pulse width modulated voltage source inverter ASD, were analyzed using computer simulations. The analysis was performed with the ASD output frequency set to 60 Hz. simulated circuit is shown in Fig.9 . The three phases of the inverter and motor circuits simulated were symmetrical. For the sake of clarity only single-phase waveforms have been included.

In order to accurately simulate the Induction Motor-ASD set, the motor needs to be simulated first without the ASD. This was done by applying pure sinusoidal and symmetrical voltages to the input nodes of the motor model. Figs.10 and 11 give the induction motor currents at full-load and no-load. In order to obtain accurate Fast Fourier Transform (FFT) analysis results, the analysis was performed at steady-state condition. From the FFT analysis of this current, Fig.13 , one can see that the induction motor model does not introduce any harmonics at its input nodes. From Figs.14, 15, 16 and 17, it is found that the simulated motor model can be used as a "black box" which resembles the 5 hp induction motor used in laboratory testing.

In pulse width modulated three-phase inverters, the harmonic content of the inverter output line voltages depends on two factors. The first is the modulating frequency used in the control of the inverter switches (triangular waveform frequency/sinusoidal waveform frequency) and the second is the modulating amplitude of the inverter switches (sinusoidal waveform amplitude/triangular waveform amplitude). By choosing a switching pattern the harmonics in the drive output can be controlled. The harmonics can be minimized and only the least harmful harmonics can be allowed to exist in the output waveform.

Using computer simulations, the voltage source inverter was modeled, and the PV array was modeled as a current controlled voltage source. This was done with the help of available models in the SABER library. Fig 15, obtained using computer simulations, shows the current and voltage waveforms of the induction motor when used with an ASD. The frequency of the inverter output voltage is equal to the frequency of the sinusoidal input of the comparator that produces the gate pulses of the inverter switches, and the inverter voltage RMS value is controlled by the modulating amplitude of the comparator inputs.

The simulation results reconfirm the reliability and high performance of induction motor drives - an already established fact.

The facts and arguments given in the preceding sections of this report supported by the discussion of Chapter 3, amply demonstrate the suitability of Induction Motor Drive and its advantages over other two drive systems, for use in the lunar based heat pump.

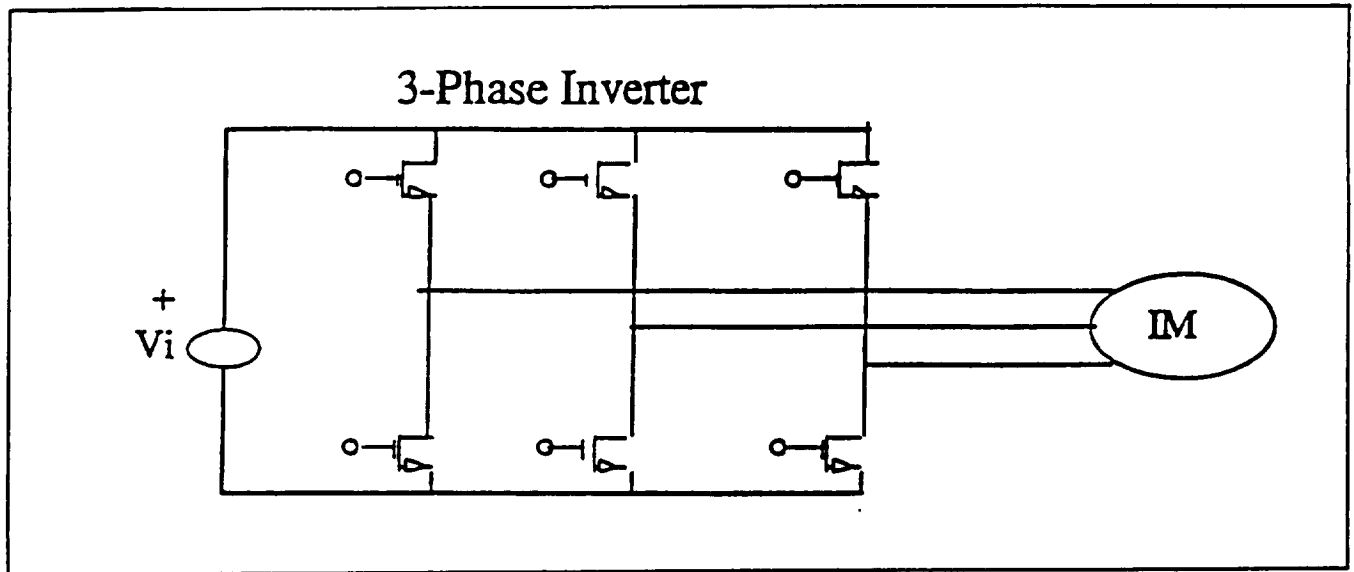

Figure 9. VSI-PWM Based IM-ASD Set.

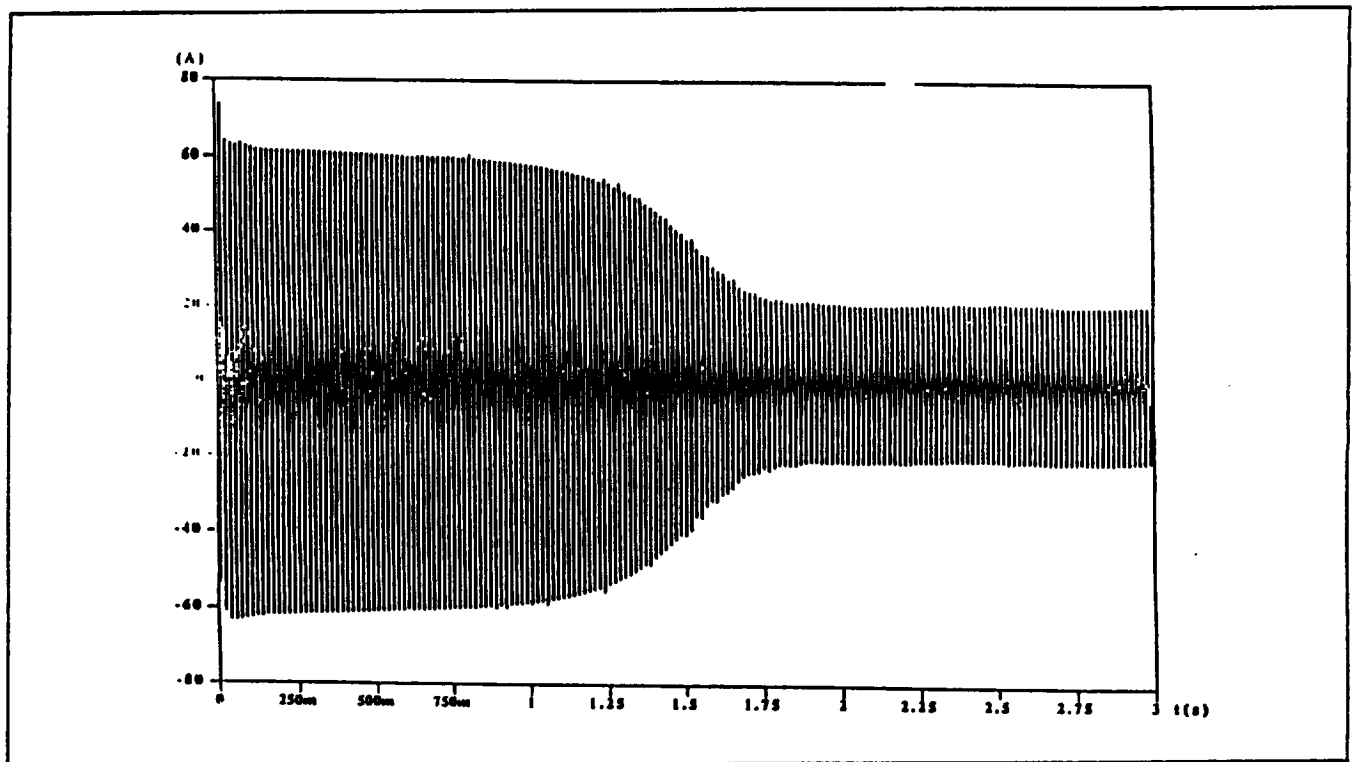

Figure 10. A 5 hp IM Current at Full-Load Without ASD.



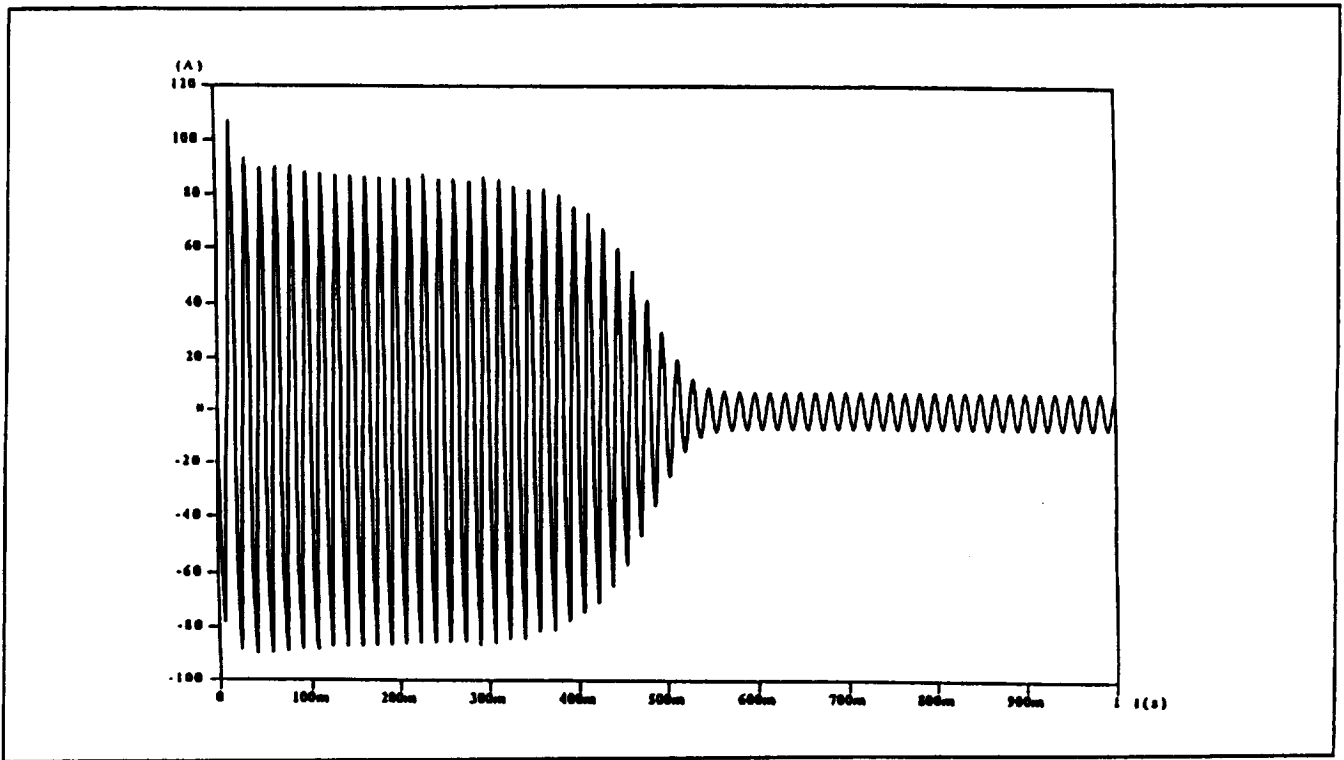

Figure 11. A 5 hp IM Current at No-Load Without ASD.

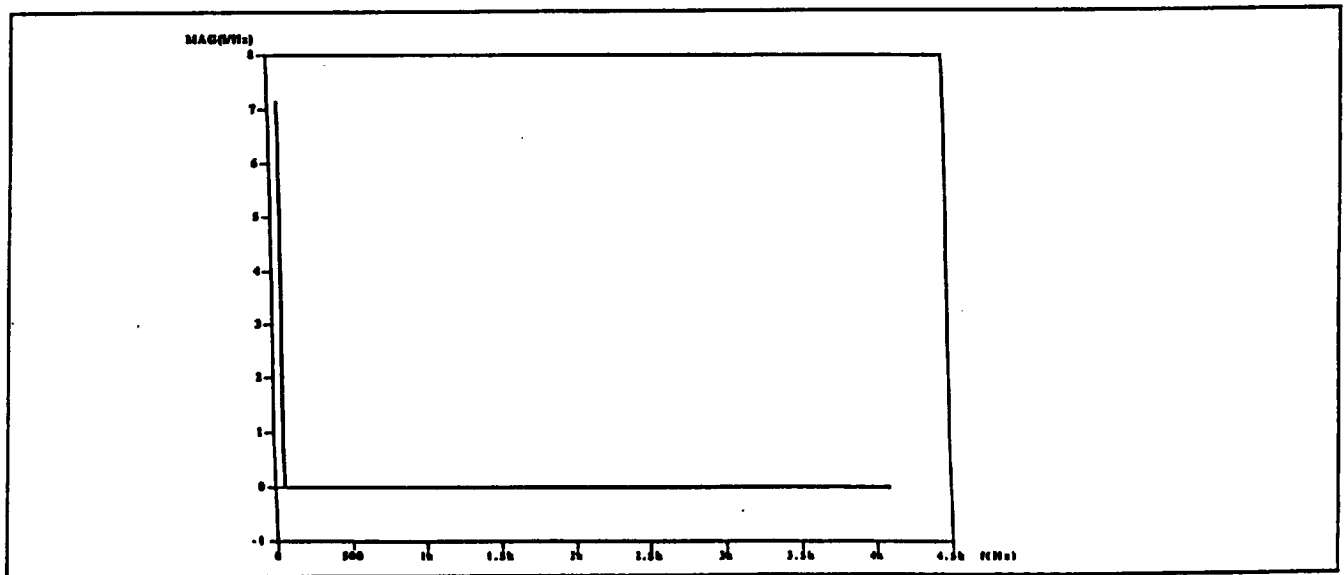

Figure 12. FFT Analysis of IM Current at No-Load.

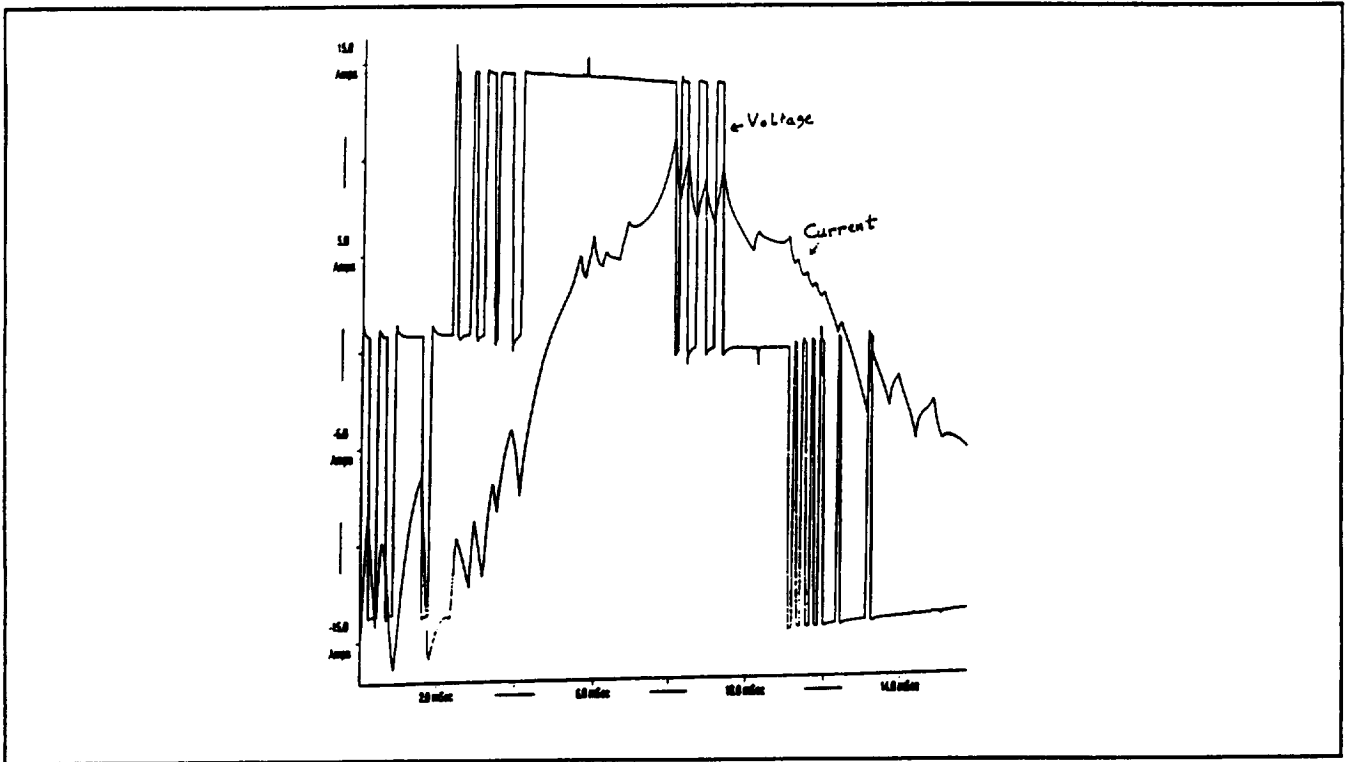

Figure 13. Laboratory Acquired IM Waveforms with ASD.

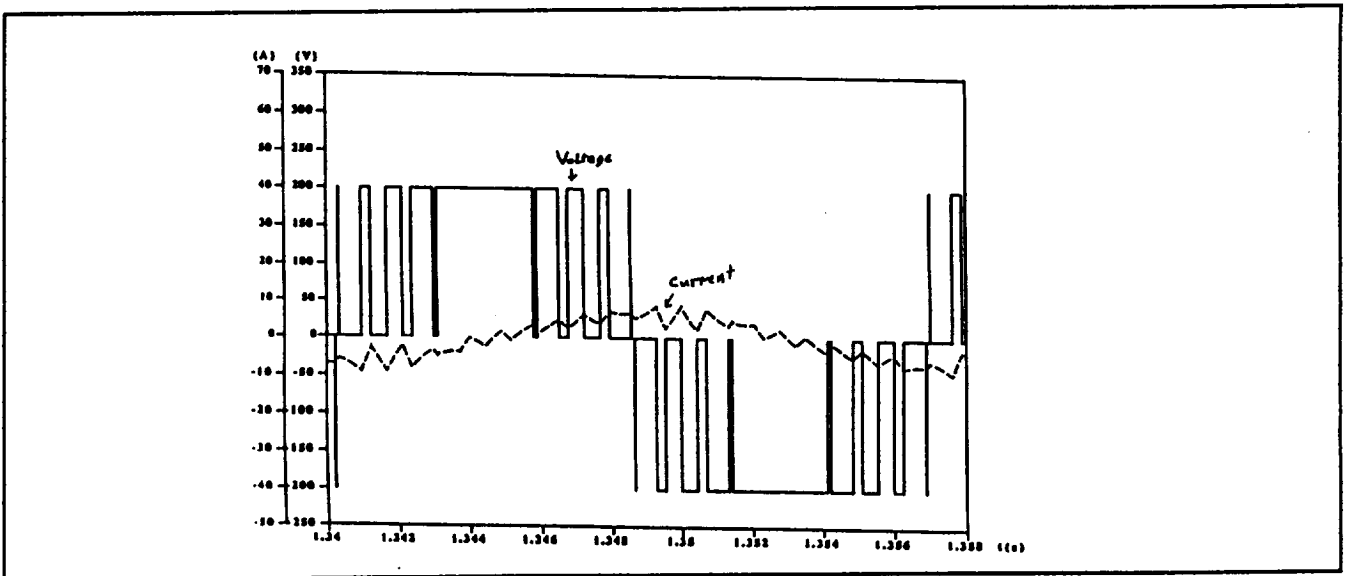

Figure 14. IM Waveforms Obtained Using IM - ASD Computer Simulations.

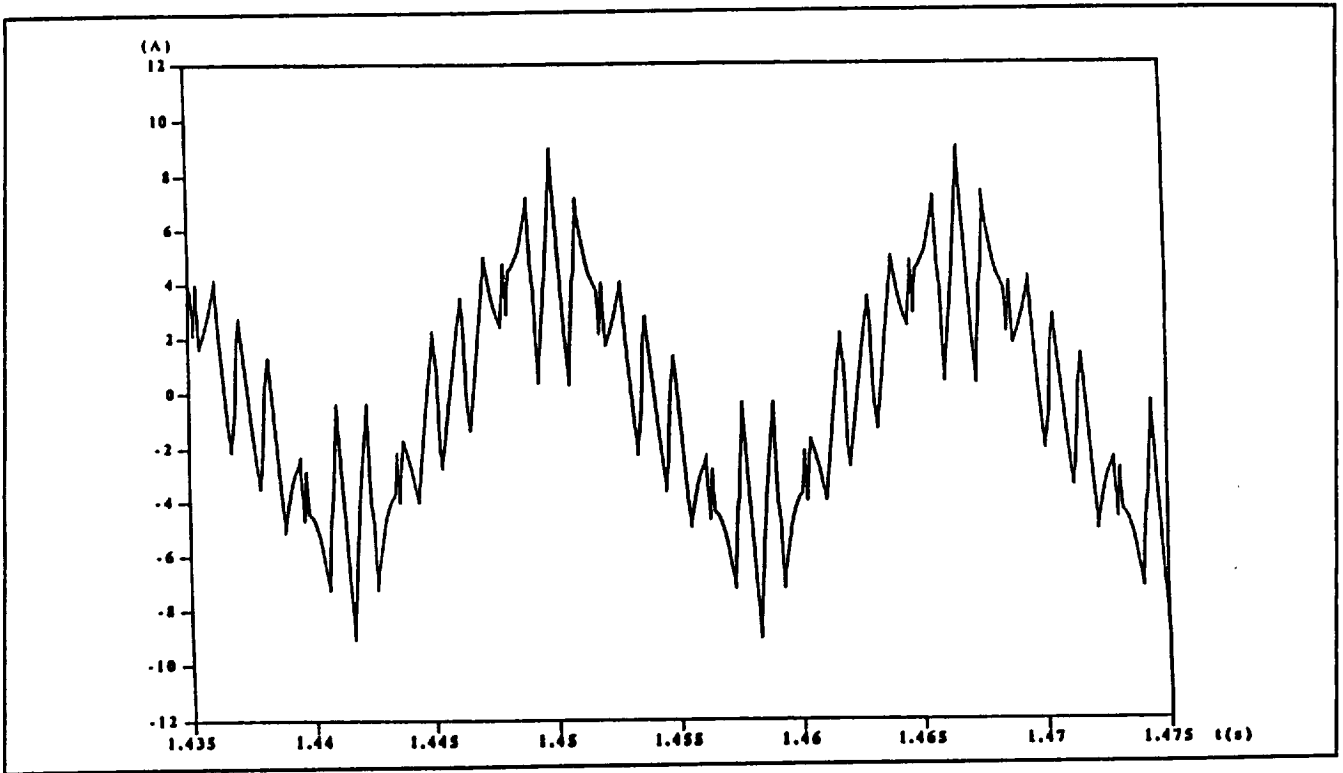

Figure 15. IM Current Obtained by Simulating PWM IM-ASD System.

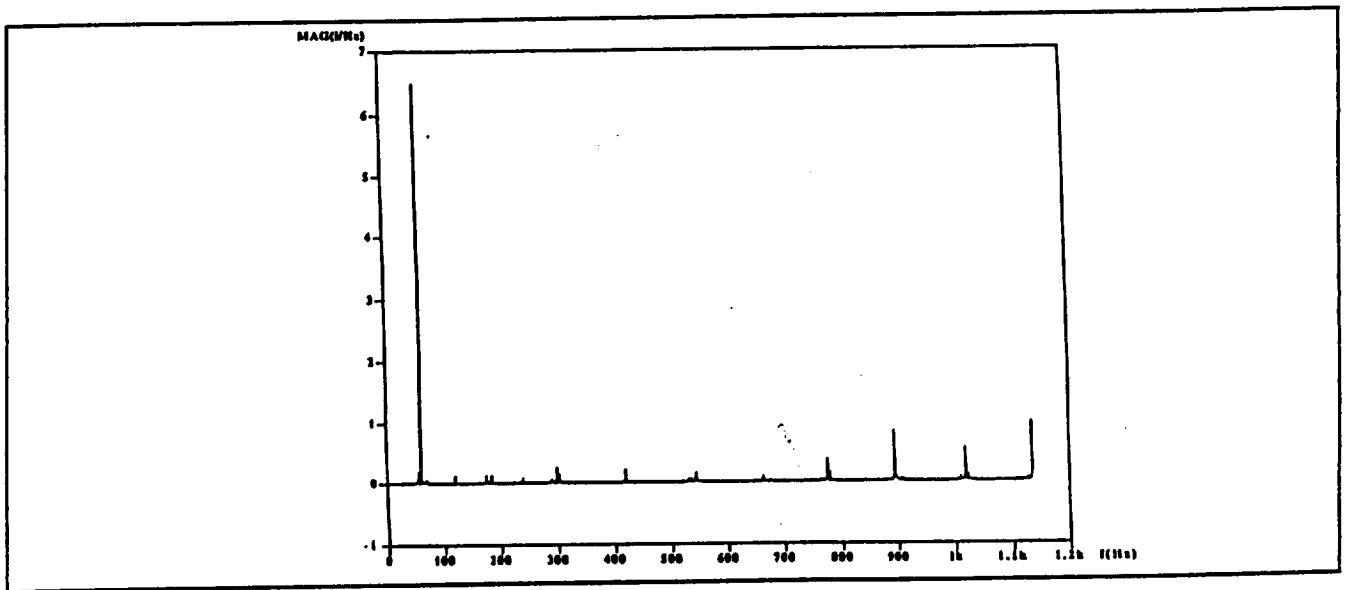

Figure 16. FFT Analysis of IM Current of Fig 16.

## 4. CONTROL OF INDUCTION MACHINES

The control of an ac machine is considerably more complex than that of the dc machine and this complexity increases if stringent performance specifications are demanded. The chief reason behind the complexity of controlling the induction motor drive is the nonlinear dynamics involved in the mathematical model of the induction motor. More over, the machine parameters may vary with saturation, temperature and skin effect, which adds further nonlinearity to the system. Several techniques have been suggested and adopted by researchers, to control such a nonlinear system. Some of these approaches have been outlined in the following sections.

### 4.1. Linear Feedback Methods

These methods, such as root-locus, pole-placement, etc., can be applied to induction motor drive system, if the system model is linearized on a small-signal perturbation basis, at a particular operating point. For example a PI controller can be designed based on the linearized model in order to achieve a volt/hertz speed control scheme with slip regulation as shown in Fig 19. However, if the operating point changes, the poles, zeros and gain of the linearized model will also change, mandating a new set of controller parameters.

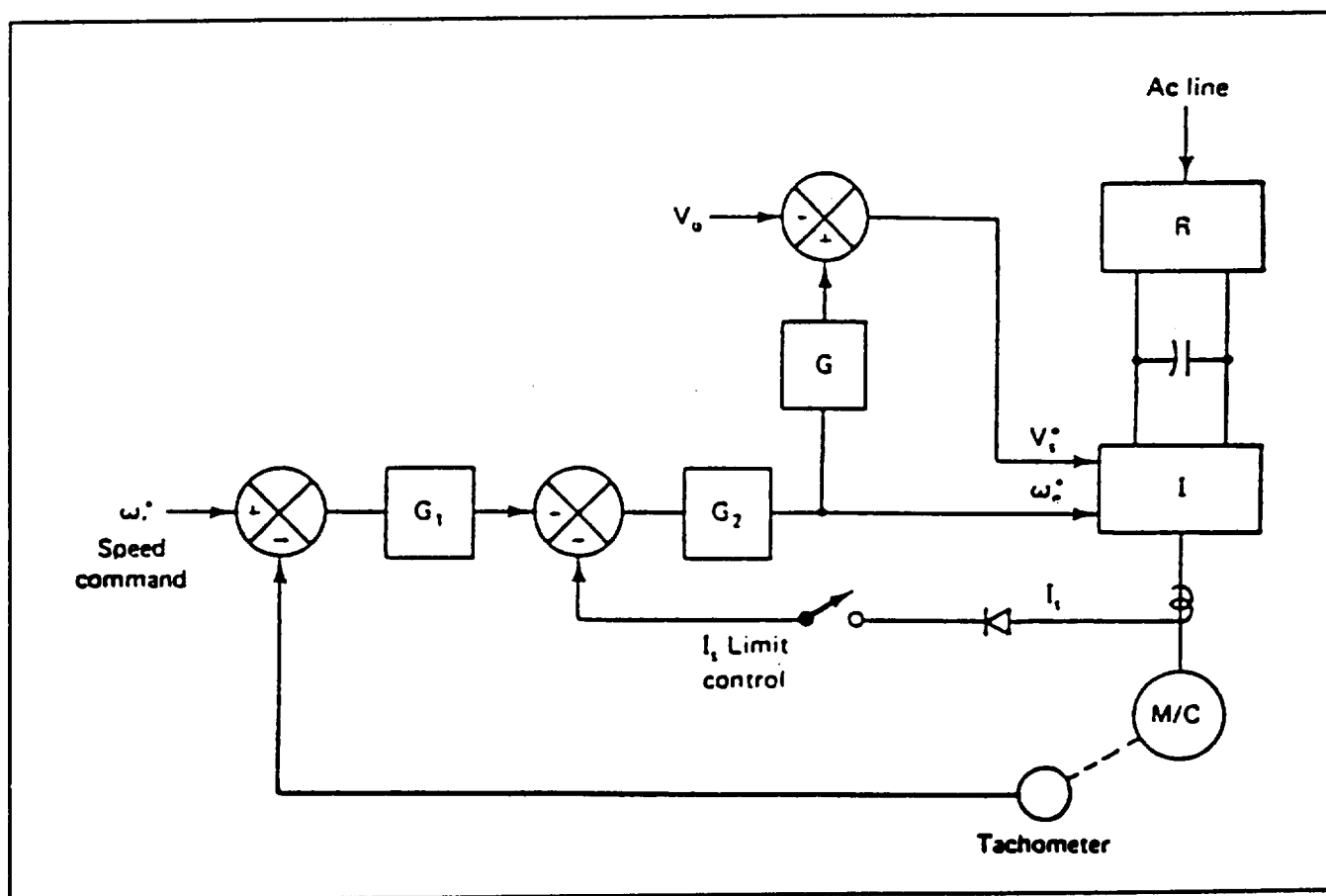

**Figure 17. Closed Loop Volts/Hertz Speed Control**

## 4.2 Nonlinear Control Technique

In recent years, a wide range of nonlinear methods for feedback control and state estimation schemes have emerged to satisfy the significant challenges in the research for improved control system designs in the presence of system nonlinearity and parameter variation [13]. Some of the most common control designs for ac machine drives, for applications requiring high performance, are based on forms of exact linearization [14].

The design concept for induction motors, using exact linearization techniques, is reflected by the two-loop structure of the controller. In the first design step, nonlinear compensation is sought which explicitly cancels the nonlinearities present in the motor (without regard to any specific control objective), and this nonlinear compensation is implemented as an inner feedback loop. In the second design step, linear compensation is derived, based on the resulting linearized dynamics of the pre-compensated motor, to achieve particular control objectives. This linear compensation is implemented as an outer feedback loop [15][16].

## 4.3 Vector Control Technique

Prior to the development of a formal theory for exact linearization design, closely related nonlinear feedback control schemes had already been developed for induction motors. The classical field oriented control or vector control technique[17] involves the transformation of electrical variables into a frame of reference which rotates with the rotor flux vector (the d-q frame). This reference frame transformation, together with a nonlinear feedback, serves to reduce the complexity of the dynamic equations, provided that the rotor flux is not identically zero. Under this one restriction, the rotor flux amplitude dynamics are made linear and decoupled, more over if the rotor flux amplitude is regulated to a constant value, the speed dynamics will also become linear and decoupled. Provided that the rotor flux amplitude may be kept constant, the field-oriented control can achieve an asymptotic linearization and decoupling, where the d-axis voltage controls the rotor flux amplitude and the q-axis voltage controls the motor speed[18]. With this type of decoupling control, the dynamics of induction motor drives is similar to that of dc drives. Although the vector control approach for induction motors has found wide acceptance in industrial applications[19], the formal use of exact linearization design mentioned in the previous section can provide alternative nonlinear control systems of comparable complexity, but achieving true (as opposed to asymptotic) linearization and decoupling of flux and torque or speed.

## 4.4 Fuzzy Logic Control.

Fuzzy logic is recently finding wide popularity in various applications that include management, economics, medicine and control systems. The application of fuzzy logic to control machine drives is almost entirely new. It is also well known that fuzzy control has been implemented in home appliances, cars, chemical processes, etc. A fuzzy control system is a real-time expert system, implementing a part of a human operator's or process engineer's expertise which can not be easily expressed in PID parameters or differential equations but rather in situation/action rules. The advantages of using fuzzy logic control usually fall into one of the following [20]:

- (i) Implementing expert knowledge for a higher degree of automation:

The knowledge of an operator about the plant under control is usually based on experience which can not be expressed in mathematical forms. This experience is often rather of the type " *if the situation is such and such I should do the following.*" In this case, fuzzy control offers a method for representing and implementing such experience.

- (ii) Robust nonlinear control.

A well designed classical PID controller can achieve the control system objectives in the vicinity of a steady-state operating point. However, substantial parameter changes or major external disturbances lead to a sharp decrease in system performance. In the presence of such a disturbance, a PID controller is faced with a trade-off between fast response with significant overshoot or smooth but sluggish response, or even worse it may be unable to stabilize the overall system. In this case, fuzzy logic control offers a better alternative to implement simple but robust solutions that cover a wide range of system parameters and cope with major disturbances.

- (iii) Reduction of development and maintenance time.

Recently [21] two idle speed controllers for an experimental car have been developed, one is a conventional PID and the other is a fuzzy logic controller. The major control goal was to keep a constant idle-speed of 800 rpm, irrespective of disturbances imposed by different road conditions or additional power consumption such as power steering and air conditioning. Practically no difference could be observed concerning the system behavior, but while almost two man-years were spent in the development of the conventional PID controller, the development time of a fuzzy controller was only about six months.

- (iv) Marketing.

In Japan "fuzzy" has become one of the most popular words. In 1990, Japanese manufacturers reported sales of fuzzy - controlled home appliances in the range of several billion US dollars.

#### 4.5. Fuzzy Logic Control for A.C. Motor Drives.

Generally, the requirements for a high performance motor drive system are :

- (i) fast tracking of set point changes without overshoot.
- (ii) the maximum speed dip and the restore time due to step lead change must be as small as possible.
- (iii) the steady state errors both in the command tracking and load regulation cases must be zero.

In order to achieve these requirements, in the case of an unknown or ill-defined dynamic model, nonlinear multidimensional system with parameter variations (such as induction motor), fuzzy logic control provides a good approach to meet the high performance drive requirements. It has been reported that fuzzy logic controllers is a good approach to meet the high performance drive requirements. It has been reported that fuzzy logic controllers have been successfully applied to dc as well as ac drives [22], [23],[24], [25], [26]. The basic configuration of a Fuzzy Logic Controller (FLC) is shown in Fig 20. It comprises four

principal components : a fuzzification interface, a knowledge base, decision-making logic and a defuzzification interface.

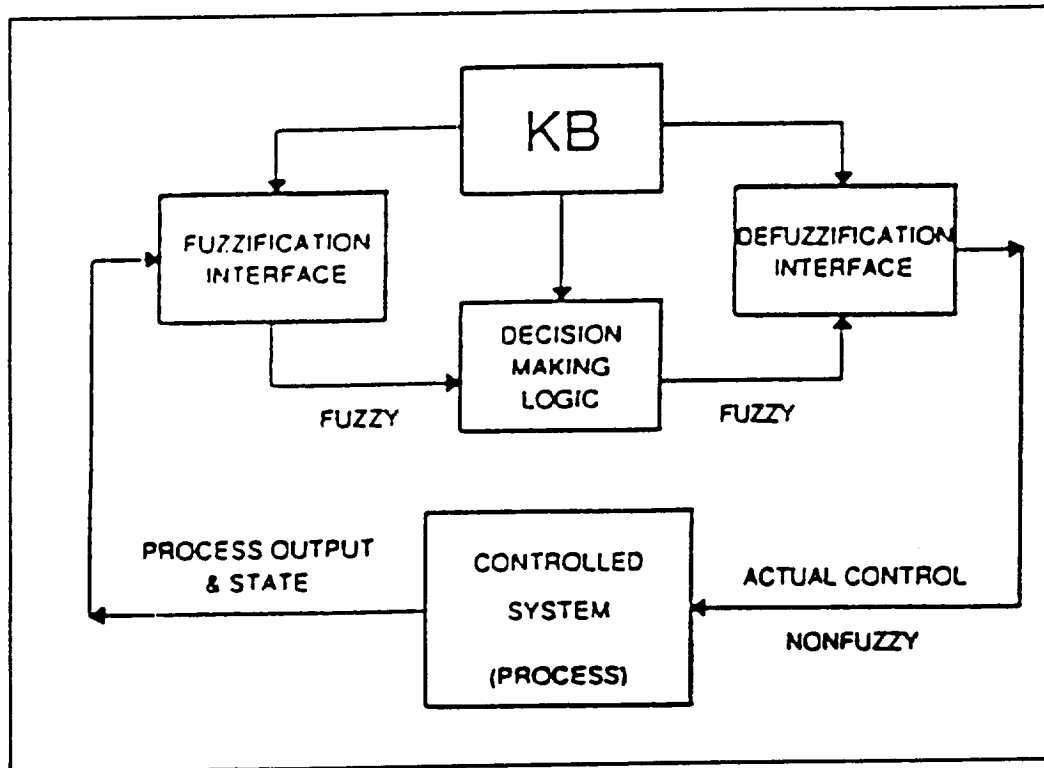

Figure 18. Basic Configuration of Fuzzy Logic Controller (FLC)

#### 4.6. Conclusion

One of the most important features of the aerospace PV heat pump driven by an adjustable speed drive system is the superior performance of the system under different operating conditions. In this respect we think that fuzzy logic control provides an efficient control scheme which is capable of satisfying the system performance requirements. From a practical point of view, the engineers who are on the front line of designing products for consumers and industrial applications, tend to use the control design approaches which are simple, efficient and easy to understand; fuzzy logic control is such an approach. As far as implementation is concerned, fuzzy logic is simple to implement. Many fuzzy VLSI chips have been developed which make the implementation of fuzzy controllers simple and fast. Furthermore, there are software tools available for designing fuzzy controllers.

Fuzzy controllers are supposed to work in situations where there is a large uncertainty or unknown variation in plant parameters and structures. Generally, the basic objective of adaptive control is to maintain consistent performance of a system in the presence of these uncertainties. Therefore, for the aerospace applications, an adaptive fuzzy logic control needs more than just a serious consideration. The most important advantage of adaptive fuzzy control over conventional adaptive control is that the adaptive fuzzy controllers are capable of utilizing linguistic fuzzy information from human operators. This is

especially important for systems with a high degree of uncertainty, such as the aerospace system. In this system, the sources of uncertainty are motor parameters, heat pump behavior, power electronic circuit operation conditions, etc. therefore it is very important to do more research work towards the development and design of a reliable and efficient fuzzy logic controller for PV array driven-induction motor drive.



## 5. POWER CIRCUIT HARDWARE

### *Introduction.*

The system hardware shall mainly comprise of the power circuit or the converter circuit, which consists of a matrix of power electronics semiconductor devices. In addition to the power circuit, an efficient triggering circuit will be needed to control the power devices of the converter. This circuit can be a signal processing circuit which would make the triggering pulses generated by the microcomputer, suitable for application to the power devices. If necessary the system hardware will also include some protection circuitry, e.g. a snubber circuit for voltage surge suppression, di/dt protection circuitry, over voltage and over current protection circuits. Lastly there will be sensing circuits for speed, current and current direction, voltage, position etc. Depending on the overall scheme none or all of the mentioned sensing circuitry will be used. For an aerospace application, very special attention must be paid to the minimization of weight and to also keeping the reliability high so schemes with minimum hardware requirements must be employed.

First of all, the choice of the most suitable power device for the power converter will be made. Here the experience of the researchers and published literature along with the requirements of the application, will be taken as the basis for the selection. Power semiconductor devices that constitute the heart of modern power electronics have been undergoing dynamic evolution in recent years [27]. The evolution of power semiconductor devices started with the Silicon Controlled Rectifiers (SCR) followed by devices like Triacs, Gate Turn Off Thyristors (GTO), Bipolar Transistors (BJT) and power MOSFETS. The more recent addition to this list are the modern power semiconductor devices such as the Insulated Gate Bipolar Transistor (IGBT), the Static Induction Transistor (SIT), the Static Induction Thyristor (SITH) and the MOS Controlled Thyristor (MCT). This section includes a review of the characteristics and features of some of the more popular of these devices. The trend in industry and research show that the IGBTs on one hand are way ahead of the older devices like SCR, GTO and BJT in terms of reliability and overall performance and on the other hand they have been successfully tested and tried more widely and thoroughly than the comparatively less popular SIT, SITH and MCT. A power semiconductor device is indeed the most complex, delicate and fragile element in a converter. A power electronics engineer needs to have a thorough understanding of the device operation and performance, for a reliable and efficient design of a power converter.

The power electronic devices used in the converter should ideally be a switching device with:

- (i) large voltage and current ratings.
- (ii) zero conduction drop.
- (iii) zero leakage current in blocking condition.
- (iv) high temperature and radiation withstand capability.
- (v) high mean time between failures (MTBF).
- (vi) near zero turn ON and turn OFF times.

The researchers in solid-state electronics have worked relentlessly to improve device fabrication techniques and come up with a close to ideal device. A device with the above mentioned ideal features may be impossible to achieve but technology has moved step by step towards the realization of a device which

is close to ideal. Two of the very important device parameters especially for computer and aerospace applications are low conduction drop and small leakage currents. Low conduction drop and small leakage current contribute to the high efficiency of the converter, and thus the cooling requirement is small. This consideration particularly in the aerospace application is more important than the energy saving aspect. Aerospace application always look for high temperature power and signal electronics, as the higher junction temperature reduces the heat sink size and therefore contributes to lower size and cost of the converter.

### *5.1. Power Semiconductor Devices*

A very brief introduction to some of the power semiconductor devices is given below:

#### *5.1.1. Thyristor*

Introduction of this device more than three decades ago started the modern age of power electronics. For the first two decades it reigned almost supreme. A thyristor is basically a three junction, four layer device having three terminals. The device is a controlled switch which can be put into conduction by forward biasing it and then applying a small triggering pulse at the gate terminal. Once the device goes into conduction the gate loses control and the removal of the gate pulse does not turn off the device. This is the biggest disadvantage of the device because it necessitates the use of sometimes bulky and less reliable commutation circuits to turn off the device, particularly in inverter operation. Also the turn ON and turn OFF times are not low enough to make the device suitable for high frequency operation. Thyristors are available up to 6000 Volt and 3500 Amp ratings.

#### *5.1.2. Gate Turn Off Thyristor (GTO)*

As the name suggests the GTO is a thyristor which like a conventional thyristor, can be turned ON by applying a positive pulse at the Gate terminal, but unlike it can be turned OFF by the application of a negative pulse at the gate. The disadvantages of the device are a poor turn OFF current gain (typically 4 or 5), so a 2000 Amp peak device may need as high as 500 Amp negative gate current pulse to turn it OFF. This can sometimes lead to hot spots or localized heating, which can damage the device. The device has high switching losses and this restricts the frequency of device operation to 1 to 2 KHz. The GTOs are available up to 4500 Volts and 3000 Amp ratings.

#### *5.1.3. Power MOSFET*

One of the other disadvantages of the thyristor and the GTO is that these devices are current control devices, this makes the device slow and reduces the device efficiency. As opposed to being current controlled the Power MOSFET is a voltage controlled device. A power MOSFET is a unipolar, majority carrier, "zero junction," voltage controlled device. Since it is a voltage controlled device, the gate circuit impedance is very high. There is no inherent delay and storage switching time and hence these devices can be operated at very high frequencies. The high switching speed causes low switching loss, and therefore it does not require a heavy snubber circuit and causes a considerable decrease in the overall weight of the power circuit hardware. A Power MOSFET has a high ON resistance which increases with the voltage rating, this makes the device very lossy at high currents. Power MOSFETs are used in high frequency switching applications within the ratings of a few watts to a few kilowatts. The state of the art

modules are available with 500 V, 140 Amp ratings.

#### 5.1.4. Insulate Gate Bipolar Transistor (IGBT)

An IGBT is a hybrid MOS-gated turn ON/OFF bipolar transistor that combines the attributes of a MOSFET, BJT and thyristor. The device is also known as a metal oxide semiconductor insulated gate transistor (MOSIGT). An IGBT has high input impedance, like MOSFETs, and low on state conduction losses like BJTs. The three terminals are base, gate and emitter. Fig 21 shows the symbol and circuit of an IGBT. The device can be turned ON by a 10 - 15 Volts base drive, it can be turned OFF by zero base drive or in other words just by withdrawing the base voltage. The device has a higher current density compared to BJT and MOSFET. The device turns ON and OFF very fast and the phenomenon is similar to MOSFET. The important property of IGBT compared to MOSFET is the significant reduction of input capacitance. The device also does not show any second breakdown phenomena. Although IGBT is more expensive than Power MOSFET and BJT, lower gate drive requirements, along with smaller snubber and lower switching loss, make the IGBT inverter more efficient with less size and weight. In aerospace applications the reduction in the hardware mass along with reliability is one of the biggest attractions. An IGBT converter can use integrated gate drive circuits which are commercially available. IGBTs with the voltage ratings up to 1200 Volts and current ratings up to 500 Amps are available. With IGBTs link frequencies of 30 to 90 KHz are practical at power levels up to 200 KW. [28]

#### 5.2. Conclusion:

Of all the power semiconductor devices available, the IGBT has a distinct edge over its competitors viz. Power MOSFET, BJT and Thyristors. The advantages of IGBT are:

1. It is a voltage controlled device, unlike the thyristors and BJT, this reduces the gate losses in the device.
2. It has low input capacitance. This makes high frequency operation possible.
3. It does not exhibit second breakdown phenomena and hence provides more reliable switching.
4. The conduction losses are low, this causes less heating of the device and reduces the size of the heat sink.
5. The snubber circuit (for  $dv/dt$  protection) size is small. This causes a significant reduction in the size and mass of the converter.

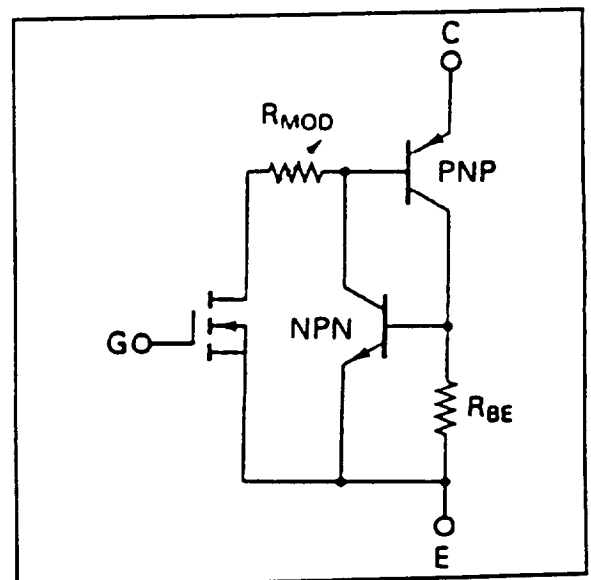

Figure 19. Equivalent Circuit of an IGBT.

## 6. CONCLUSION

The aim of this research is to select the most suitable PV driven motor drive system for an aerospace application. Of the three drive systems, namely the induction motor, switched reluctance motor and the brushless dc motor, it was found that the induction motor drive system holds maximum promise. There is a trend of using "energy efficient" motors for special applications where efficiency is one of the major criteria for selection. These motors which are known as "energy efficient motors" are the three phase squirrel cage induction motors. The other very important feature of these motors is that they are reliable, because of their robust structure. These motors can be made to run at very high speeds and thus can significantly reduce the motor mass. By choosing an appropriate modulation technique for a PWM induction motor drive, the load side and the supply side harmonics can be selectively eliminated or reduced. The induction motor characteristics can be linearized around the range of normal operation, thereby making it possible to simplify the control algorithm. Based on the published literature and manufacturers' experience, the advantages of using the induction motor drive for aerospace applications seem to be overwhelming, particularly in light of the shortcomings of the other two types of ac motors. The main disadvantages of the permanent magnet machine being the phenomenon of permanent demagnetization, necessity of position and speed sensors, and difficulty in running the motor at speeds much higher than the base speed. The switched reluctance motor has the problem of very high torque ripple and the presence of acoustic noise.

Depending on the overall design of the electrical system and the nature of the electrical load on the system, in terms of sensitivity to harmonics different ASDs may be used for the application. Two possible systems for a lunar based heat pump were shown in Fig 5 and Fig 6. Fig 7 shows a new proposed layout named "UF I - enhanced reliability design". Here by using the speed and temperature signals, along with a predetermined computer logic the reliability of the system is enhanced by putting the heat pump on the fuel cell in case of the PV array failure. A detailed discussion on this has already been included in chapter 2.

### *6.1. Scope for Further Research*

The later phases of the research project would consist of development and design of the induction motor drive system and testing its performance experimentally in the power laboratory and running simulations on the computer. A thorough analysis of the final drive system under transient and steady state will be carried out. Reliability and efficiency tests under adverse operating conditions will be conducted. Load side and supply side harmonic analysis and means of harmonic reduction will be performed.

An important part of the future research can be the development and design of a reliable and efficient fuzzy logic controller for the PV array driven-induction motor drive. Fuzzy logic control techniques have been tested and found to work very well for systems where there is a large uncertainty or unknown variations in system parameters. These controllers have the ability of utilizing linguistic information from human operators. In the fuzzy logic system, the operator has the possibility of interfering with the automatic control strategy. His interference is not a necessity, but when he interferes, it is done in a well defined way that has been decided through the definition of special operator-activated control objectives. In Japan, fuzzy logic techniques have already been used in home appliances, camcorders and cameras and represent an overall business of several billion dollars. The possibility of using other classical control techniques independently or in conjunction with fuzzy control will also be investigated.

## 6.2. Industrial Applications

From the industrial application point of view, induction motor drives equipped with efficient microcomputer based controllers have an excellent potential for many commercial applications like:

- \* PV Driven Refrigeration.
- \* Heating Ventilating and Air Conditioning (HVAC).
- \* PV Driven Electric Vehicles
- \* Other Motor Applications.

One of the applications of solar energy driven induction motor drives is PV array driven refrigerators. These refrigerators can be used, to name a few, for medical applications, normal and remote terrestrial applications and aerospace applications. The PV driven refrigerators can be used in manned space stations, for preserving soil or other samples, chemicals and medicines and many other items that need to be stored at a low temperature, in order to preserve them. For the aerospace application the most economical and convenient source of energy is the solar energy. Hence photovoltaic driven devices are very popular for such applications. These devices need to be cost effective, energy efficient, highly reliable, precisely controlled and environmentally benign. In addition these devices should need minimum maintenance.

A PV array driven motor drive system can be designed to operate in a refrigeration system. The system can be fully controlled using control techniques like fuzzy logic control. As already stated in section 4.5 of this report, the fuzzy logic control schemes are robust and highly reliable with features like high flexibility of control and simplicity of implementation. These drives can be operated in closed loop, using temperature sensing schemes and control philosophies similar to those described in chapter 3.

Depending on the performance criteria, various other schemes like vector control or Pulse Width Modulated (PWM) control can be designed and implemented. Being a computer control scheme, a lot of software features can be incorporated with ease and simplicity. This can be for example, a constant temperature monitoring and alarm feature. The system will generate an alarm signal if the temperature were to rise above a certain predefined safe level. The PV array driven refrigerators has a very good potential of being a subject of detailed research. A significant input can be given to the research and development of such systems. A cost effective and suitable scheme can be designed and implemented. It will be expected to be highly reliable and energy efficient. A prototype can be developed and put together in the laboratory. This could be put to rigorous laboratory testing to obtain its performance level, in terms of efficiency and reliability. These data could be backed up and verified by running computer simulations of the system. Computer simulations can also be used to do destructive testing of the system. One of the other features of the PV array driven systems is their characteristic of being environmentally safe.

## *References*

- [1]. Paice, D.A., " Speed Control of Large induction motors by Thyristor Converters. IEEE Trans on Ind Gen Application, Vol. IGA-5, Sep/Oct 1969.
- [2]. Bose, B.K., " Adjustable Speed ac drives - A Technology Status Review. " IEEE Proc, Vol 70, No.2, 1983.
- [3]. Bowes, S.R. and Davis, T., " Microprocessor based Development System for PWM Variable Speed Drivers." IEE Proc, Vol. 32, Pt. B, No. 1, Jan 1985.
- [4]. Boast, M.A. and Ziogas, P.D., " State of Art Carrier PWM Techniques: A Critical Evaluation." IEEE Trans on IA Vol. 24, No. 2, March/April 1988.
- [5]. Matsui, N., and Shigyo, M., " Brushless dc Motor Control without Position and Speed Sensors." IEEE Trans. on Industrial Application., Vol. 28, No. 1, Jan/Feb 1992. pp. 120-127.
- [6]. Sebastian, T., " Temperature Effects on Torque Production and Efficiency of PM Motors Using NdFeB Magnets." IEEE Trans. on IA Vol. 31, No.2, Mar/Apr 1995. pp. 353-357.
- [7]. Bose, B.K., "Power Electronics and Motion Control - Technology Status and Recent Trends." IEEE Trans on Industrial Applications, Vol. 29, NO. 5, Sep/Oct 1993. pp 902 - 909.
- [8]. Safi.S.K., Acarnley.P.P., and Jack.A.G., "Analysis and Simulation of the high-speed torque Performance of Brushless DC Motor drives." IEE Proc. Electr. Power Appl., Vol 142, No. 3, May 1995. pp. 191-200.
- [9]. Morimoto, S., Sanada, M., and Takeda, Y., " Effects and Compensation of Magnetic Saturation in Flux-Weakening Controlled Permanent Magnet Synchronous Motor Drives." IEEE Trans. on Industrial Applications, Vol. 30, No. 6, Nov/Dec 1994. pp. 1632-1637.
- [10]. Xu, L., Ye, L., Zhen, L., and El-Antably, A., " A New Design Concept of Permanent Magnet Machine for Flux Weakening Operation." IEEE Trans. on IA, vol. 31, No. 2, Mar/Apr 1995. pp. 373-378.
- [11]. Moallem, M. and Ong, C., " Predicting the Steady State Performance of a Switched Reluctance Machine." IEEE Trans. on IA, Vol. 27, No. 6, Nov/Dec 1991. pp. 1087-1097.
- [12]. Hussain, I., and Ehsani, M., " Rotor Position Sensing in Switched Reluctance Motor Drives by Measuring Mutually Induced Voltages." IEEE Trans. on Industrial Applications, Vol. 30, No. 3, May/Jun 1994. pp. 665-672.
- [13]. Taylor, D.G., " Nonlinear Control of Electric Machines: An Overview." Control System Magazine, Vol. 14, No. 6, Dec 1994. pp 41 - 51.

- [14]. Isidori, A., " Nonlinear Control Systems, 2nd ed., New York, NY: Springer -  
Verlage, 1989.
- [15]. De Luca, A. and Ulivi, G., " Design of an exact nonlinear controller for  
induction motors." IEEE Trans. on Automatic Control, Vol. 34, No. 2, pp 1304  
- 1307.
- [16]. Krzeminski, Z., " Nonlinear Control of Induction Motor." Proceedings of the  
10th IFAC World Congress, Munich Germany, pp 349 - 354, 1987.
- [17]. Blaschke, F., " The Principle of Field Orientation Applied to the New Trans  
Vector Closed-Loop Control System for Rotating Field Machines." Siemens'  
Review, Vol. 39, pp 217- 220, 1992.
- [18]. Vas, P., " Vector Control of ac Machines." Oxford, Clarendon Press, 1990.
- [19]. Bose, B.K., " Power Electronics and Motion Control - Technology Status and  
Recent Trends." IEEE Trans. on Industrial Applications, Vol. 29, No. 5,  
Sep/Oct 1993. pp 902 -909.
- [20]. Driankov, D., Hellendoorn, H., and Reinfrank, M., " An Introduction to Fuzzy  
Control." New York, NY: Springer - Verlag, 1993.
- [21]. Driankov, D., Hellendoorn, H., and Reinfrank, M., " An Introduction to Fuzzy  
Control." New York, NY: Springer - Verlag, 1993.
- [22]. Sousa, G.C. and Bose, B.K., " A Fuzzy Set Theory Based Control of a Phase -  
Controlled Converter DC Machine." IEEE Tran. IA Vol. 30, No. 1, Jan/Feb  
1994, pp 34-44.
- [23]. Liaw, C.M. and Wang, J.B., " Design and Implementation of a Fuzzy  
Controller for a High Performance Induction Motor Drive." IEEE Tran.  
Systems, Man and Cybernetics, Vol. 21, No. 4, Jul/Aug 1991, pp 921-929.
- [24]. Kung, Y.S. and Lian, C.M., " A Fuzzy Controller Improving a Linear Model  
Following Controller for Motor Drives." IEEE Trans. Fuzzy Systems, Vol. 2,  
No. 3, Aug 1994, pp 194-202.
- [25]. Mir, S.A., Zinger, D.S. and Elbuluk, M.E., " Fuzzy Controller for Inverter fed  
Induction Machine." IEEE Trans. Ind. Appl., Vol. 30, No. 1, Jan/Feb 1994, pp  
78-84.
- [26]. Lian, C.M. and Cheng, S.Y., " Fuzzy Two Degree of Freedom Speed  
Controller for Motor Drives." IEEE Trans. Industrial Electronics, Vol. 42, No.  
2, April 1995, pp 209-216.
- [27]. Bose, B.K., " Evaluation of Modern Power Semiconductor Devices and Future  
Trends of Converters." IEEE Trans. on Industrial Applications, Vol. 28, No. 2,  
Mar/Apr 1992, pp. 403-413.

- [28]. Kurnia, A., Hassan, C., and Divan, D.M., " Impact of IGBT Behavior on Design Optimization of Soft Switching Inverter Topologies." IEEE Trans. on Industrial Applications, Vol. 31, NO. 2, Mar/Apr 1995, pp. 280-286.