

NASA / CR-1998 207436

FR-1005

19 February 1998

IN-15CR
068509

FINAL REPORT

BANTAM SYSTEM TECHNOLOGY PROJECT

Contract NAS8-97319

Prepared by:

J.M. Moon

J. R. Beveridge

Prepared for:

National Aeronautics and Space Administration

George C. Marshall Space Flight Center

Marshall Space Flight Center, Alabama 35812

Table of Contents

- 1.0 Introduction**
 - 1.1 Purpose**
 - 1.2 Scope**
- 2.0 Applicable Documents**
- 3.0 Utilization of Study Results**
 - 3.1 Principles**
 - 3.2 Procedures and Methods**
- 4.0 Requirements Summary**
 - 4.1 Overall**
 - 4.2 Data and Command System**
- 5.0 Operations Concept and Plan Summary**
 - 5.1 Overall**
 - 5.2 Data and Command System**
- 6.0 Data System Architecture**
 - 6.1 Overall**
 - 6.2 Data and Command System**
- 7.0 Market Survey**
 - 7.1 Approach**
 - 7.2 Systems Surveyed**
 - 7.3 Rank Ordering**
- 8.0 Test Plan**
 - 8.1 Overall**
 - 8.2 Data and Command System**
- 9.0 Communications**
- 10.0 Conclusions**
- 11.0 Recommendations**
 - 11.1 Overall**
 - 11.2 Data and Command System**

1.0 Introduction

The Low Cost Booster Project (LCBP), also known as Bantam, is an element of the Advanced Space Transportation Program focused on Low Cost Booster Technologies. During FY 00 flight demonstrations are planned to demonstrate the feasibility of producing a booster capable of inserting a 150 kg payload into low earth orbit. The ground support system is an element of the full launch system. The ground support system includes the Data and Command System (DCS), mission planning system and simulation system. This report focuses on the DCS which provides for integration of the payload with the launch vehicle, preparation of the vehicle for launch (including maintenance, integration and test of the vehicle flight software), monitor and control of the launch sequence, range safety during launch, and collection of telemetry during the flight up to payload release. The ground support system is intended to make the maximum possible use of Government Off-the-Shelf (GOTS) or Commercial Off-the-Shelf (COTS) hardware and software to obtain the best value in terms of development operations support and ultimate life cycle cost for the launch system.

1.1 PURPOSE

The purpose of this document is to provide an analysis of existing off the shelf products for the Bantam DCS. This constitutes the final report under Contract NAS8-97319. The information in this document has been collected with the goal of assisting the launch vehicle contractors with concepts which can be useful in structuring their ground systems, and data concerning potential off the shelf products which can be used to implement these systems. A typical system architecture is provided for reference and to establish a basis for configuration of the proposed vendor systems to make comparisons more consistent. This document contains high level summaries of the requirements document and operations concept produced earlier. Additionally, low cost communications concepts are discussed. The rankings of the products are provided to establish a context for discussion of the systems. In selecting these or other systems for use in their launches the contractors may weight evaluation criteria differently, depending on the needs of their own vehicle, and may consider other criteria in evaluating these products.

1.2 SCOPE

The elements covered in this document are the DCS hardware and software required to perform the direct launch support activities for the Bantam development vehicle. Personnel requirements are not directly addressed, although the selection of a ground support system could have a significant impact if it requires greater or lesser manpower to operate and/or maintain. This is factored in as a part of the evaluation criteria for the systems. It was also a fundamental consideration in identifying the system architecture which directly affects the costing of proposed systems.

2.0 Applicable Documents

LCBT-PP	LCBT Program Plan
MSFC-RQMT-2674A	Low Cost Booster Program (LCBP) Propulsion Test Article (PTA1) Systems Requirements Document
MSFC-SPEC-2675	LCBT Fastrac 60K Engine Specification
MSFC-DOC-2678	LCBT Fastrac 60K Engine Interface Definition Document
NTI TR-1018	Bantam System Technology Project, Ground System Requirements
NTI TR-1019	Bantam System Technology Project, Ground System Operations Concept and Plan
W-7-NA-71011	Candidate Bantam System Operations Concept, Universal Space Lines, Inc.
W-7-NA-71011	Bantam NRA 8-15 November 1997 Report, Universal Space Lines, Inc.
	Discovery Mission Operations Handbook, NASA Jet Propulsion Laboratory, April 1994
	Low Cost Mission Operations Workshop; NASA Jet Propulsion Laboratory, April 1994
	Satellite Operations: Determining a Path to the Future; United States Air Force, Office of the Department of Defense Space Architect, September 1997
	New TDRSS Communications Options for Small Satellites; NASA Goddard Space Flight Center, 1996

3.0 Utilization of Study Results

This study was intended for use as a tool in the analysis of candidate off the shelf systems for possible use as the basis for a Bantam Launch Control System. Every attempt was made to make the survey as complete as possible, but there may be other viable candidates available for such a system. Complete contact information is provided for each of the vendors surveyed. Although a ranking is presented we would expect that the prime contractors would choose a vendor based on their own unique needs and capabilities.

3.1 PRINCIPLES

The fundamental principle of this study is to determine a DCS which represents the *best value* for the Bantam Program. The best value system is considered as that which delivers the required functionality in a reliable manner at the lowest overall life cycle cost.

Low overall cost is emphasized by:

- limiting the DCS requirements to those needed as opposed to those nice to have
- acquiring a functional system as opposed to developing a system
- minimizing the work required to integrate the system components internally and externally
- ensuring that the system acquired will easily integrate within the overall ground system
- ensuring that the system is easy to set up and operate
- ensuring that the system provides for high operator productivity and effectivity
- ensuring that the system is stable and can function without frequent updates/upgrades

Reliability is emphasized by:

- ensuring that the acquired system has been proven
- ensuring that the system is based on components which are proven and stable
- ensuring that system suppliers are well established and likely to be around if/when the system requires maintenance and/or upgrade.

3.2 PROCEDURES AND METHODS

Several steps led to this report. First the fundamental requirements for the ground system were identified through analysis and discussions with spaceports, payload sponsors and vehicle manufacturers. Next an operations concept was defined based on these inputs to provide insight into the probable implementation of the ground system. From these a candidate DCS architecture was defined which would meet these requirements. Finally a market survey was performed to identify potential products which could meet the requirements, using the proposed architecture as a basis to ensure that we were comparing relatively compatible versions of the vendor products.

4.0 Requirements Summary

A proposed set of system requirements is presented as a guide for use in definition of the ground support system. For a detailed set of requirements see NTI-TR-1018.

4.1 OVERALL

Ground system requirements are defined to accept a payload with a detailed definition of its planned mission which is processed by the mission planning system to generate mission specific parameters for the flight software. These are checked and optimized through the mission simulator. When the payload is ready for launch it will be shipped to the launch site where the ground operations team will integrate the payload with its launch vehicle, prepare the vehicle for launch, control all aspects of the actual launch and collect telemetry as necessary to assess vehicle performance.

4.2 DATA AND COMMAND SYSTEM

The fundamental requirements are for the DCS system to monitor and control vehicle preparation for launch, interface to the vehicle for final flight software upload and launch release, monitor telemetry during the flight, provide appropriate support for the range safety function, and retain a detailed data archive of all activities and telemetry collected during the prelaunch and launch phases. The DCS provides the specific service required to control launch operations and collect associated data. The fundamental requirement is that the control center is able to monitor all required operations and the associated data at all times during the launch sequence. The data itself is archived and maintained so that it can be analyzed during post flight operations with the purpose of improving operations and assessing the root causes of any mission failures.

5.0 Operations Concept and Plan Summary

The operations concept and plan provide a framework for alternative methodologies for implementation of the system requirements. They provide a viewpoint which aids in assessment of proposed implementations using off the shelf components to accomplish the ground support mission.

5.1 OVERALL

The central concept of the Operations Plan is to achieve a low recurring cost through the optimal use of automated systems. The integrated ground system consists of three primary segments, the Mission Planning System, the Simulation System and the DCS. The Mission Planning System takes inputs from the payload sponsor and uses them to determine the parameters for the flight software to use for the launch. The Simulation System is used during the mission design phase to help define and test the flight software, and later during operations is closely coupled with the Mission Planning System to evaluate the generated parameters. The Data and Command System provides for monitoring and control of the vehicle during the prelaunch and launch processes. It uses the output from the mission planning system as an input to the vehicle during final flight software upload.

5.2 DATA AND COMMAND SYSTEM

To meet the Bantam objectives for efficiency and reliability the DCS is conceived as a highly automated, data driven system, capable of supporting multiple vehicles and short turnaround times with a small core cadre of operations personnel. The DCS also has additional functionality as a test monitor during vehicle production. This provides efficiency in developing only a single, consistent set of tests for system and subsystem checkout from manufacturing all the way through launch. It also ensures that built in and DCS controlled tests are fully checked out well before the first launch.

The project launch support crew is projected to be two to three controllers, each with an independent workstation. Launch processing is automated and includes appropriate displays to keep the operators fully informed on the progress of the launch activities and on caution and warning systems to detect and display problems. Complete data archiving is provided to ensure that anomalies can be resolved and to provide the basis for simulation updates and launch crew training. Positive control of the launch process will be maintained through procedural holds and the capability for manual aborts at any time.

Data is collected and displayed during the flight phase, but except for range safety destruct mechanisms no commands are sent to the vehicle. All telemetry is logged and archived. The primary mechanism for anomaly resolution is postflight analysis of this data, so although it may be displayed in real time, the display is for information only except for any data provided to the range safety function.

6.0 Data System Architecture

The overall Ground System Architecture and the DCS Architecture were developed to satisfy the requirements in the Ground System Requirements document, based on the concepts in the Operations Concept and Plan. Additionally they are in concert with the concepts presented in the Uni-

versal Space Lines documents.

6.1 OVERALL

The Ground System as a whole consists of three primary components, the Mission Planning System (MPS), the Simulation (SIM), and the Launch Control Center which is facilitated/automated by the DCS. These are illustrated in Exhibit 6.1-1. The MPS and SIM are closely coupled, as the simulation is an integral part of the process of mission analysis. The primary reason they are considered separate is that the simulation will almost certainly be developed as an independent system and it has significant uses outside of the mission planner. The Data and Command System is that portion of the ground system which actually controls the test, prelaunch and launch processes. The DCS architecture is required to interface with and facilitate the overall Ground System.

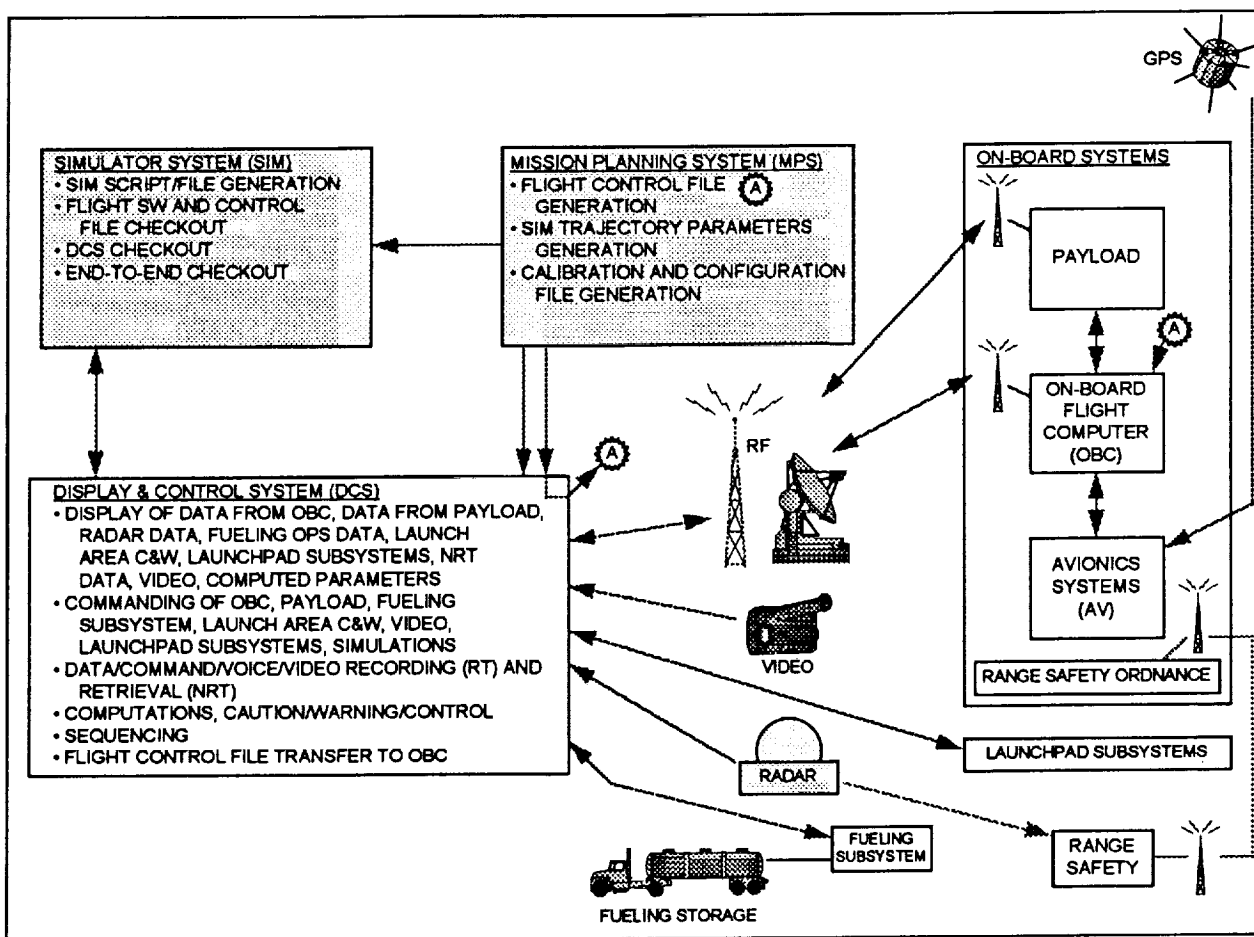

Exhibit 6.1-1 Ground System Overview

6.2 DATA AND COMMAND SYSTEM

The data and command system is concerned with two primary functions, first to monitor and

control the events leading up to the launch of the vehicle, and second, to receive, display and record telemetry data from the vehicle in flight. The DCS may also provide interfaces for remote monitoring of launchsite activities. Typically it consists of hardware interfaces to the vehicle and ground support equipment on the pad, and a radio frequency (RF) telemetry link with the vehicle for collection of in flight data, as illustrated in Exhibit 6.1-1. The data collected from either the ground or flight instrumentation is time tagged and recorded by the DCS for post flight analysis.

7.0 Market Survey

7.1 APPROACH

To conduct the market survey, we contacted multiple organizations identified with spacecraft and launch command and control. In addition, we took an extensive look at companies providing telemetry products. The most fruitful search methodology proved to be use of the Internet to find companies advertising their wares. All of the major players have web sites, and these were often informative.

The data contained in our Requirements and Operations Concept documents was used to define the basis for analysis of the proposed systems from the various vendors. Criteria used for evaluation were of two different types, pass-fail requirements and subjective criteria. Finally cost rankings were generated for the surveyed products.

7.1.1 Pass-Fail Criteria

The following table (Exhibit 7.1-1) identifies the individual requirements which each product was evaluated against. It should be noted that some of these requirements are met by elements outside of the normal function of the products evaluated. For example, the range safety function is outside of the normal launch control system area of direct responsibility. Configuration management is normally provided by a separate product. All of these were included because some of the systems evaluated had notable contributions in these areas, and we wanted to ensure completeness of our requirements evaluation.

Requirement
Generic <ul style="list-style-type: none"> • Configurable to support any Bantam vehicle • Adaptable to all spaceports
Monitor and display status of all physical interfaces
Monitor and display status of flight software

Provide positive management and control of mission specific software/data	Configuration Management must be handled by the ground system, but not necessarily directly by the DCS application
Verify correct upload of mission specific software/data	
<p>Launch sequence monitor and control of:</p> <ul style="list-style-type: none"> • Ground equipment (interface units, sensors, voice and video, electrical systems, fire suppression, weather) • All prelaunch vehicle servicing (cryo, propellants, gasses, etc) • Launch vehicle health and status (built in test initiation and monitoring) • Launch vehicle internal sensors (built in test) • OBC checkout and monitor • Software/data upload verification • RF downlink interfaces for payload and vehicle • Payload health and status 	
<p>Launch sequence manual control must provide</p> <ul style="list-style-type: none"> • Preplanned holds • Manual abort at any time (with checks to ensure proper safing etc.) • Final launch initiation • Appropriate range safety interfaces for prelaunch phase 	
Recording of all vehicle to ground system information passed, with time tags	
Capability to archive and retrieve recorded data	
Interface to telemetry collection for launch data	

Support for range safety function

Range safety typically is an independent function, apart from our DCS system, though they should communicate

Exhibit 7.1-1 - Pass-Fail Criteria

7.1.2 Subjective Criteria

The subjective criteria below were used to provide differentiation among the products based on factors other than the ability to meet the system requirements. These take into account value added aspects of the products such as the degree of automation of the system, and risk factors such as supplier stability and product maturity.

- Supplier stability - ability to provide ongoing level of maintenance for life of program

This is an important criterion, but one which has some conflicting issues. It is possible that the lowest cost solution could come from a startup company which is hungry for the business and willing to go an extra mile to get it. Innovative solutions are certainly likely from these small companies. It should be noted that all of the commercial players in this evaluation are small companies. The dominant factor in the ranking as presented is the risk associated with supporting the product over a long life cycle.

level 1 - Startup company with low capitalization and no viable work beyond this contract

level 2 - New company with other work, but little track record

level 3 - Established company with multiple other related contracts

level 4 - Established company with multiple product lines and contracts

level 5 - Major corporation with multiple product lines and contracts

- Maturity - degree to which proposed system has been tested, used and/or exercised

Until recently the launch control function remained with the government or the vehicle manufacturer, and there were no off the shelf products. The majority of the off the shelf products which have emerged had their origins in test control, satellite control or both. Actual launch vehicle control experience is very limited. Therefore this is a strong discriminator. There is an open question to a certain extent whether a product based on an existing launch control technology but with no operational experience should be rated higher than one with demonstrated success in a different field.

level 1 - Custom product

level 2 - New product in first release

- level 3 - New product based on existing system with successful history
- level 4 - Off the shelf product with demonstrated success in related applications
- level 5 - Off the shelf product with demonstrated success in the same application

- **Configurability - ease of adapting to different missions**

The inherent needs of the field dictate a similar approach to configurability among the contenders. In order to be a viable product it is necessary to provide certain core capabilities, thus a modular design is the most common. Preference is shown toward an open systems approach, since the use of COTS products from other vendors to enhance the system provides an easy upgrade path when better capabilities come onto the market. More importantly, this eases the integration of the DCS with the other elements of the Ground Operations System.

- level 1 - Custom design for each mission
- level 2 - Component design adapted for each mission
- level 3 - Component design with strong Applications Program Interfaces (APIs) and tools provided
- level 4 - Generic with APIs and existing interfaces to commonly required COTS products

- **Adaptability - support of different launch vehicles**

This is an area where there is little difference among the viable contenders. All of the proposed solutions use a component design, and all will require some degree of development to adapt to the specific vehicles. Each includes tools to aid in this development.

- level 1 - Custom design for each vehicle
- level 2 - Component design adapted for each vehicle
- level 3 - Component design with APIs and tools for adapting to vehicles
- level 4 - Component design with existing tools for most vehicles

- **Expandability - ability to extend capabilities as required**

The fact that each of the proposed solutions is already modular indicates that this is an inherent capability for all of them. Some may have a greater flexibility, and possibly more proven interfaces. CORBA compliance extends computability with other software packages, possibly at the cost of performance. This criteria should be questioned by the raters as to its applicability to their design.

- level 1 - Custom software
- level 2 - Some components available for common functions
- level 3 - Multiple components with APIs available
- level 4 - Multiple components, multiple existing COTS interfaces, well documented APIs
- level 5 - All potential needs can be met from single source, with COTS interfaces pre

done and fully functional. CORBA compliant

- **Ease of use - clear user interfaces, intuitive displays and configurable output**

This is not just an appearance issue. In order to allow operation of the system with a small core of operators it is necessary to provide intuitive, easily understood user interfaces. The operator must be presented with information as clearly as possible to enable adequate control.

level 1 - Required displays provided through custom interface

level 2 - Multiple standard displays provided covering basic functionality

level 3 - Multiple displays with APIs for third party user interface

level 4 - Multiple displays, APIs and very adaptable displays

level 5 - Full set of predefined displays, capability for operator to customize for his own applications

- **Automation - usable by small cadre of console operators**

This evaluation factor is one of the most important discriminators. Our emphasis is on reducing recurring costs for the operational phase of the program, and one of the primary ways of accomplishing this is to perform our launches with the minimum manpower level. This requires automated systems which reduce the workload and increase the handling capacity for the operators. Approaches which have been proposed include scripting capabilities for the system, active limit sensing and handling, and artificial intelligence approaches.

level 1 - Primarily manual monitor and control

level 2 - Efficient setup to ease operator load, still a level of manual control

level 3 - System procedurally automated

level 4 - Automated procedures, limits and sensing, system aids operator in visualizing and handling anomalies

level 5 - Fully automated system, operator intervention only at preplanned points

- **Integration - single provider has full range of hardware and software solutions**

A fully integrated system has the benefit of allowing the developer to concentrate on vehicle specific development and not worry about integrating hardware and software.

level 1 - Hardware or software only

level 2 - Hardware or software with cooperative agreements for integration

level 3 - Produces most equipment and software, some external

level 4 - Produces most required ground support equipment with custom integration required

level 5 - Turnkey operation, all hardware and software fully integrated

- **Platform availability - availability on variety of computational platforms**

level 1 - Single platform dependent

level 2 - Cross platform, single operating system (non UNIX)

level 3 - Cross platform, UNIX

level 4 - Multiple platform, UNIX and Windows NT

Once a ranking against the factors presented is accomplished the scores must be normalized, since the scales are not equal. This is accomplished by defining a scaled score which is essentially the raw score as a percentage of the maximum possible score. Finally a weighting factor must be assigned to each of the factors since they are simply not equally important.

7.1.3 Weighting of Subjective Criteria

Each of the criteria above, except cost, was assigned a weight. The sum of the weights is 100 so that each may be considered to be a percentage assigned to the criterion. When the weights are multiplied times the scaled scores, the result is a weighted score. The maximum possible score per criteria is 4 or 5, depending on the criteria. The weighted score is determined by the following formulas:

Scaled Score = (Raw Score / Maximum Possible Score) expressed as a percent

Weighted Score = Scaled Score * Weight

The following table defines the weights we assigned to each of the factors:

Evaluation Criteria	Weight	Rationale
Supplier stability	10	This is given a moderate weight as we felt that it is important to ensure ongoing support for our system through the operational phase
Product Maturity	15	This was highly rated to reflect the belief that a mature system is more likely to support the short development schedule of Bantam, and will be more stable as a product. It also should increase overall reliability over the long term.
Configurability	5	This reflects the component nature of the product and the ability to add on other components. This is a fairly important factor, but not a significant discriminator among the evaluated systems
Adaptability	15	This feature captures the ease of system development contained within the product.
Expandability	5	We expect the DCS to remain stable after the initial development, and do not expect there will be a significant need to expand the capabilities
Ease of use	15	This is largely related to the operator friendly features of the system, and was rated high as anything

		which reduces operator workload and increases
Automation	15	This feature is important to allow the DCS to function with a minimal crew and to allow operations without the use of highly specialized personnel
Integration	15	The emphasis here is on the ability to minimize the effort to integrate the system internally and externally
Platform availability	5	Availability over a variety of hardware platforms provides flexibility in implementation

7.2 SYSTEMS SURVEYED

The following companies were interviewed and product demonstrations viewed:

Altair Aerospace Corporation, Bowie MD

Command and Control Technologies Corporation, Titusville, FL

Integral Systems, Inc, Lanham, MD

L3 Communications, San Diego, CA

Storm Integration, Inc, Herndon, VA

Software Technology, Inc, Melbourne, FL

Veda Systems, Inc, California, MD

In addition government organizations were contacted for data on the possibility of using government off the shelf items. It should be noted that at least one of the products above was a government system being sold under a technology license from NASA.

7.2.1 Commercial Off the Shelf Systems

In order to provide a valid comparison among the various systems under consideration a common configuration was defined to represent the standard ground system. This configuration is for a single stream of telemetry data, required workstations and software to provide support to a three operator ground station, and appropriate hardware. In the final cost rankings only the software was quoted, except as noted, as each of the systems is capable of supporting any telemetry acquisition system. The ability of several of the vendors to provide a turnkey system is desirable, and this is captured in the integration score in the performance rating section.

All prices given are list prices for off the shelf items, and none of the estimates include costs for mission unique development. To a certain extent this cost is considered in the subjective evalua-

tion. Those systems with high ratings for configurability, ease of use and automation could be expected to have lower costs associated with the mission unique development.

7.2.1.1 Altair Aerospace Corporation

Altair is a small company, currently with about 35 employees, experiencing rapid growth. They are well established, with multiple significant contracts currently active, and have an experienced and effective engineering organization. They have the capability to provide a completely turnkey system, and have done so for some satellite ground stations. They are among the few vendors with actual launch control experience with their system, having used it to support the Connestoga launch.

Criteria	Met	Comments
<p>Generic</p> <ul style="list-style-type: none"> • Configurable to support any Bantam vehicle • Adaptable to all spaceports 	<p>✓</p> <p>✓</p>	<p>Altair has a very open architecture, with powerful modeling tools for adapting to multiple vehicle support. They are currently involved with ground system setups at Florida and Akjuit space ports</p>
<p>Monitor and display status of all physical interfaces</p> <p>Monitor and display status of flight software</p> <p>Provide positive management and control of mission specific software/data</p> <p>Verify correct upload of mission specific software/data</p> <p>Launch sequence monitor and control of:</p> <ul style="list-style-type: none"> • Ground equipment (interface units, sensors, voice and video, electrical 	<p>✓</p> <p>✓</p> <p>✓</p> <p>✓</p>	<p>No built in CM tools, expect user to supply this function</p> <p>Specific support for mission software management</p>

<p>systems, fire suppression, weather)</p> <ul style="list-style-type: none"> • All prelaunch vehicle servicing (cryo, propellants, gasses, etc) ✓ • Launch vehicle health and status (built in test initiation and monitoring) ✓ • Launch vehicle internal sensors (built in test) ✓ • OBC checkout and monitor ✓ • Software/data upload verification ✓ • RF downlink interfaces for payload and vehicle ✓ • Payload health and status ✓ <p>Launch sequence manual control must provide</p> <ul style="list-style-type: none"> • Preplanned holds ✓ • Manual abort at any time (with checks to ensure proper safing etc.) ✓ • Final launch initiation ✓ • Appropriate range safety interfaces for prelaunch phase ✓ <p>Recording of all vehicle to ground system information passed, with time tags ✓</p> <p>Capability to archive and retrieve recorded data ✓</p> <p>Interface to telemetry collection for launch data ✓</p> <p>Support for range safety function ✓</p>		
		Multiple time types
		Provided direct range safety support on Conestoga

Evaluation Criteria	Raw Score	Scaled Score	Weighted Score	Comments
Supplier stability	3	60	6	
Product maturity	5	100	15	This is one of the most mature products in the survey, having been used on multiple existing systems and in an actual launch system application
Configurability	4	100	5	
Adaptability	3	75	11.25	
Expandability	4	80	4	
Ease of use	4	80	12	
Automation	5	100	15	The basis of the automation of the system is in the use of operational models which incorporate state recognition and state transition functions to monitor and control activities. This is a significant difference from other vendors approaches.
Integration	5	100	15	Altair has the capability to deliver a fully integrated turnkey system
Platform availability	4	100	5	Multiple platforms, Unix and NT
Total Score			88.25	
Cost		S/W 70,000		

7.2.1.2 Command and Control Technologies Corporation

Command and Control Technologies is a startup company which has licensed an existing NASA tool and enhanced and expanded on its capabilities. The principals of the company are very experienced in the launch control field, with direct experience applying the capabilities they are marketing to launch operations. They have several other technology contracts with NASA in the field of launch support, not directly involved with this tool, and they continue to cooperate with the NASA engineers in developing their system. Another factor is that they are focused solely on launch systems, which ensures that they clearly understand exactly what is required for this specific application.

The first release of their product is not due till this summer, so it is untried. Since it is based on existing technology the element of risk is significantly reduced, but the full system is has never been actually implemented. The system has been used for launch control, so in that aspect it has some significant advantages over systems which are primarily from other areas and adapted for launch control. The first product which they are marketing is the core module of the system, and many capabilities would be required from other COTS software, for example the user interface. The demonstration included direct examples of interfaces with G2, an artificial intelligence engine, and Dataviews, which is widely used to provide GUI capabilities in this field.

Criteria	Met	Comments
Generic <ul style="list-style-type: none"> • Configurable to support any Bantam vehicle • Adaptable to all spaceports 	✓ ✓	
Monitor and display status of all physical interfaces	✓	
Monitor and display status of flight software	✓	
Provide positive management and control of mission specific software/data		No CM support, user to supply CM functions

Verify correct upload of mission specific software/data	✓	
Launch sequence monitor and control of:		
• Ground equipment (interface units, sensors, voice and video, electrical systems, fire suppression, weather)	✓	
• All prelaunch vehicle servicing (cryo, propellants, gasses, etc)	✓	
• Launch vehicle health and status (built in test initiation and monitoring)	✓	
• Launch vehicle internal sensors (built in test)	✓	
• OBC checkout and monitor	✓	
• Software/data upload verification	✓	
• RF downlink interfaces for payload and vehicle	✓	
• Payload health and status	✓	
Launch sequence manual control must provide		
• Preplanned holds	✓	
• Manual abort at any time (with checks to ensure proper safing etc.)	✓	
• Final launch initiation	✓	
• Appropriate range safety interfaces for prelaunch phase	✓	
Recording of all vehicle to ground system information passed, with time tags	✓	
Capability to archive and retrieve recorded data	✓	

Interface to telemetry collection for launch data	✓	
Support for range safety function	✓	

Evaluation Criteria	Raw Score	Scaled Score	Weighted Score	Comments
Supplier stability	2	40	4	Startup with very experienced people, many from Delta Clipper
Product Maturity	4	80	12	System is licensed from NASA, has been used for launch control in past, major enhancements being made. Score was enhanced to reflect that the product has been used in launch applications, not just related field
Configurability	3	75	3.75	
Adaptability	3	75	11.25	
Expandability	3	60	3	
Ease of use	3	60	9	
Automation	3	60	9	
Integration	1	20	3	
Platform availability	4	100	5	NT port due at end of summer
Total Score			60	
Cost				Specific costing depends on final configuration, exact figures were not available. Costs are estimated to be in line with the average cost for these types of systems.

7.2.1.3 Integral Systems, Inc

Integral Systems is a solidly established company providing satellite ground control stations for a variety of foreign and domestic satellite systems. Their system is mature and stable and has demonstrated reliability.

Criteria	Met	Comments
<p>Generic</p> <ul style="list-style-type: none"> • Configurable to support any Bantam vehicle • Adaptable to all spaceports 	<p>✓</p> <p>✓</p>	
<p>Monitor and display status of all physical interfaces</p> <p>Monitor and display status of flight software</p> <p>Provide positive management and control of mission specific software/data</p> <p>Verify correct upload of mission specific software/data</p> <p>Launch sequence monitor and control of:</p> <ul style="list-style-type: none"> • Ground equipment (interface units, sensors, voice and video, electrical systems, fire suppression, weather) • All prelaunch vehicle servicing (cryo, propellants, gasses, etc) • Launch vehicle health and status (built in test initiation and monitoring) • Launch vehicle internal sensors (built in test) 	<p>✓</p> <p>✓</p> <p>✓</p> <p>✓</p> <p>✓</p> <p>✓</p> <p>✓</p> <p>✓</p>	

<ul style="list-style-type: none"> • OBC checkout and monitor • Software/data upload verification • RF downlink interfaces for payload and vehicle • Payload health and status 	<ul style="list-style-type: none"> ✓ ✓ ✓ ✓ 	
<p>Launch sequence manual control must provide</p> <ul style="list-style-type: none"> • Preplanned holds • Manual abort at any time (with checks to ensure proper safing etc.) • Final launch initiation • Appropriate range safety interfaces for prelaunch phase 	<ul style="list-style-type: none"> ✓ ✓ ✓ ✓ 	
Recording of all vehicle to ground system information passed, with time tags	✓	
Capability to archive and retrieve recorded data	✓	
Interface to telemetry collection for launch data	✓	
Support for range safety function		

Evaluation Criteria	Score	caled Score	Weighted Score	Comments
Supplier stability	4	80	8	
Product maturity	4	80	12	
Configurability	3	75	3.75	
Adaptability	3	75	11.25	
Expandability	4	80	4	

Ease of use	5	100	15	
Automation	4	80	12	
Integration	5	60	9	
Platform availability	3	75	3.75	
Total Score			78.75	
Cost		S/W 115,000		This price is based on a three workstation configuration at 35000 per workstation (hardware and software)

7.2.1.4 L3 Communications

L3 Communications is primarily a supplier of hardware systems applicable to the ground control system function. For system software they normally team with Storm Control Systems to provide a total solution. Since most of the criteria in this evaluation are based on the functions of the software in the system we will defer this evaluation to the Storm section.

7.2.1.5 Storm Integration

Storm provides a solution strongly oriented toward intelligent automation of the system. The core of their automation suite is the G2 package, which is integrated into their system to provide intelligent monitor and control of the launch sequence

Criteria	Met	Comments
Generic <ul style="list-style-type: none"> • Configurable to support any Bantam vehicle • Adaptable to all spaceports 	✓ ✓	
Monitor and display status of all physical interfaces	✓	
Monitor and display status of flight software	✓	
Provide positive management and control of mission specific software/data		
Verify correct upload of mission specific software/data	✓	
Launch sequence monitor and control of: <ul style="list-style-type: none"> • Ground equipment (interface units, 	✓	

sensors, voice and video, electrical systems, fire suppression, weather)		
• All prelaunch vehicle servicing (cryo, propellants, gasses, etc)	✓	
• Launch vehicle health and status (built in test initiation and monitoring)	✓	
• Launch vehicle internal sensors (built in test)	✓	
• OBC checkout and monitor	✓	
• Software/data upload verification	✓	
• RF downlink interfaces for payload and vehicle	✓	
• Payload health and status	✓	
Launch sequence manual control must provide		
• Preplanned holds	✓	
• Manual abort at any time (with checks to ensure proper safing etc.)	✓	
• Final launch initiation	✓	
• Appropriate range safety interfaces for prelaunch phase	✓	
Recording of all vehicle to ground system information passed, with time tags	✓	
Capability to archive and retrieve recorded data	✓	
Interface to telemetry collection for launch data	✓	
Support for range safety function		

	Raw Score	Scaled Score	Weighted Score	Comments
Supplier stability	3	60	6	
Maturity	4	80	12	
Configurability	4	100	5	
Adaptability	3	75	11.25	
Expandability	4	80	4	
Ease of use	4	80	12	
Automation	5	100	15	
Integration	4	80	12	Considered as combination of L3 and Storm
Platform availability	3	75	3.75	
Total Score			81	
Cost		S/W 113,235		

7.2.1.6 Software Technology

STI is well established, with over 15 years of experience in satellite command/control and telemetry system experience. Their product is based on an automated test environment (as are several others in the field) which lends emphasis to integration of the ground system software into the factory test of the launch vehicle.

Criteria	Met	Comments
Generic <ul style="list-style-type: none"> • Configurable to support any Bantam vehicle • Adaptable to all spaceports 	✓ ✓	
Monitor and display status of all physical interfaces Monitor and display status of flight software Provide positive management and control of mission specific software/data Verify correct upload of mission specific software/data Launch sequence monitor and control of: <ul style="list-style-type: none"> • Ground equipment (interface units, sensors, voice and video, electrical systems, fire suppression, weather) • All prelaunch vehicle servicing (cryo, propellants, gasses, etc) • Launch vehicle health and status (built in test initiation and monitoring) 	✓ ✓ ✓ ✓ ✓ ✓ ✓	

<ul style="list-style-type: none"> • Launch vehicle internal sensors (built in test) ✓ • OBC checkout and monitor ✓ • Software/data upload verification ✓ • RF downlink interfaces for payload and vehicle ✓ • Payload health and status ✓ 	
<p>Launch sequence manual control must provide</p> <ul style="list-style-type: none"> • Preplanned holds ✓ • Manual abort at any time (with checks to ensure proper safing etc.) ✓ • Final launch initiation ✓ • Appropriate range safety interfaces for prelaunch phase ✓ 	
<p>Recording of all vehicle to ground system information passed, with time tags ✓</p>	
<p>Capability to archive and retrieve recorded data ✓</p>	
<p>Interface to telemetry collection for launch data ✓</p>	
<p>Support for range safety function</p>	

	Raw Score	Scaled Score	Weighted Score	Comments
Supplier stability	3	60	6	
Maturity	4	80	12	
Configurability	4	100	5	

Adaptability	3	75	11.25	
Expandability	4	80	4	
Ease of use	5	100	15	
Automation	4	80	12	
Integration	1	20	3	
Platform availability	4	100	5	
Total Score			73.25	
Cost		S/W 80,250		

7.2.1.7 Veda Systems

Veda Systems is the most established company in this field. They have build telemetry systems for aircraft, spacecraft and multiple other applications for many years. Their product line is fully featured, including both the hardware and software needed to integrate the ground control system. They have provided portions of systems as well as turnkey solutions in the launch control area. In addition to launch control they also provide systems used in range safety, which gives them additional credibility in this arena.

Criteria	Met	Comments
Generic <ul style="list-style-type: none"> • Configurable to support any Bantam vehicle • Adaptable to all spaceports 	✓ ✓	
Monitor and display status of all physical interfaces Monitor and display status of flight software Provide positive management and control of mission specific software/data Verify correct upload of mission specific software/data Launch sequence monitor and control of: <ul style="list-style-type: none"> • Ground equipment (interface units, sensors, voice and video, electrical systems, fire suppression, weather) • All prelaunch vehicle servicing (cryo, propellants, gasses, etc) • Launch vehicle health and status (built 	✓ ✓ ✓ ✓ ✓ ✓	

<p>in test initiation and monitoring)</p> <ul style="list-style-type: none"> • Launch vehicle internal sensors (built in test) ✓ • OBC checkout and monitor ✓ • Software/data upload verification ✓ • RF downlink interfaces for payload and vehicle ✓ • Payload health and status ✓ <p>Launch sequence manual control must provide</p> <ul style="list-style-type: none"> • Preplanned holds ✓ • Manual abort at any time (with checks to ensure proper safing etc.) ✓ • Final launch initiation ✓ • Appropriate range safety interfaces for prelaunch phase ✓ <p>Recording of all vehicle to ground system information passed, with time tags ✓</p> <p>Capability to archive and retrieve recorded data ✓</p> <p>Interface to telemetry collection for launch data ✓</p> <p>Support for range safety function ✓</p>	<p>Veda is particularly capable in this area as several range safety functions already use some of their system</p>
--	---

Evaluation Criteria	Raw Score	Scaled Score	Weighted Score	Comments
Supplier stability	4	80	4	Veda is one of the best established

				players in this field with significant experience in multiple types of systems.
Product maturity	5	100	15	Well established system, being used on other launch vehicles and in multiple other applications
Configurability	4	100	5	Exceptionally robust telemetry and calibration tools
Adaptability	3	75	11.25	
Expandability	4	80	4	
Ease of use	4	80	12	
Automation	2	40	6	Automation features would have to be added on using other COTS tools
Integration	5	100	15	Veda has the strongest set of existing off the shelf interfaces and products. Their products would be strong candidates for the hardware interfaces even if another vendor supplied the software.
Platform availability	4	100	5	
Total Score			77.25	
Cost			48,000	This cost figure includes a significant portion of the telemetry hardware, based on an NT server.

7.2.2 Government Off the Shelf Systems

7.2.2.1 Enhanced HOSE System (EHS)

The EHS is an updated version of the SpaceLab payload control system, intended to provide payload control for Space Station experiments. It is also being used as the ground control system for the Advanced X-Ray Astrophysical Facility (AXAF), and will be deployed to several other sites for Space Station control, including Kennedy and Langley Space Centers. This is an exceptionally capable system, designed for high data rates and handling large quantities of data. It is completely data driven, designed to be easily reconfigurable. The system has not been actually used for mission support, however it has been tested with real world telemetry. This system will be used to support Space Station, so it should be maintained for the life of that program, providing added stability.

The major question mark with this system is how easily it can be scaled down to be useable in the Bantam environment. Also a system this flexible can require a steeper learning curve for operations personnel.

Criteria	Met	Comments
<p>Generic</p> <ul style="list-style-type: none"> • Configurable to support any Bantam vehicle • Adaptable to all spaceports 	<p>✓</p> <p>✓</p>	
<p>Monitor and display status of all physical interfaces</p> <p>Monitor and display status of flight software</p> <p>Provide positive management and control of mission specific software/data</p> <p>Verify correct upload of mission specific software/data</p> <p>Launch sequence monitor and control of:</p> <ul style="list-style-type: none"> • Ground equipment (interface units, sensors, voice and video, electrical systems, fire suppression, weather) • All prelaunch vehicle servicing (cryo, propellants, gasses, etc) • Launch vehicle health and status (built in test initiation and monitoring) • Launch vehicle internal sensors (built in test) • OBC checkout and monitor 	<p>✓</p> <p>✓</p> <p>✓</p> <p>✓</p> <p>✓</p> <p>✓</p> <p>✓</p> <p>✓</p> <p>✓</p>	<p>The EHS system is much more capable with its internal CM capabilities than any of the commercial offered systems</p>

<ul style="list-style-type: none"> • Software/data upload verification ✓ • RF downlink interfaces for payload and vehicle ✓ • Payload health and status ✓ 	
<p>Launch sequence manual control must provide</p> <ul style="list-style-type: none"> • Preplanned holds ✓ • Manual abort at any time (with checks to ensure proper safing etc.) ✓ • Final launch initiation ✓ • Appropriate range safety interfaces for prelaunch phase ✓ 	
Recording of all vehicle to ground system information passed, with time tags ✓	
Capability to archive and retrieve recorded data ✓	
Interface to telemetry collection for launch data ✓	
Support for range safety function	

Evaluation Criteria	Raw Score	Scaled Score	Weighted Score	Comments
Supplier stability	5	100	10	Government
Product maturity	3	60	9	
Configurability	4	100	5	The system is more custom than any of the commercial systems, however the built in configurability is exceptionally robust
Adaptability	3	75	11.25	

Expandability	4	80	4	The EHS system is designed to handle significantly larger and more complex tasks than envisioned for Bantam, so expandability should not be an issue
Ease of use	5	100	15	The system provides an exceptionally well defined, consistent user interface, and easy to use operator configurability
Automation	4	80	12	
Integration	5	100	15	This system would require integration with one of the off the shelf hardware front ends.
Platform availability	3	75	3.75	
Total Score			85	
Cost			500,000	This cost includes all hardware, software, installation and training for operators. It does not include vehicle specific configurations.

7.2.2.2 U. S. Army Systems

We contacted several branches within the Aviation and Missile Command - Missile Research and Development Center to investigate possibilities for technology transfers from Army ground support and fire control systems to the Bantam ground support system. We found that their work on such systems is limited and invariably peculiar to a specific weapon system. In general, Research and Development (R&D) versions of their ground support systems are of a prototype nature, while "production" systems are highly optimized for producibility and use of the specific weapon system in the field. Whereas R&D versions of missiles may be extensively instrumented, these instruments are monitored by ground systems which are test range support oriented and which include capabilities in excess of those required for the Bantam Program.

The Army's general approach to weapon systems development is worthy of note. During the R&D flight phase, comprehensive data is collected to monitor system and subsystem performance. These data are analyzed and modifications are made to the weapon system based on the data collected. Once the point is reached where the weapon system is pronounced ready for fielding, the volume of data collected for "analysis" virtually goes to zero (along with the cost associated with collecting/analyzing the data). The weapon system is produced in relatively large quantities according to the as-built design resulting from the R&D activity. The resulting system provides enough operational data to ensure the soldier in the field that the weapon is in a state of readiness

for launch/utilization. It also provides enough data for problem diagnosis. The control subsystem is, in most cases, extremely straightforward and extensive enough to get the job done reliably.

It is suggested that this Army approach to development and operations be seriously considered for Bantam development and operations. That is, engineer the overall Bantam system (rocket, ground support system, all of it) with the idea in mind that after it proves itself during a reasonably short R&D period, it will truly become an "operational" space flight vehicle. Once operational, it will simply be used to do the job for which it was intended. It will not be constantly monitored, tinkered with and optimized as these activities would almost certainly preclude the possibility of achieving the \$1.5 M per launch cost goal.

7.3 RANK ORDERING

7.3.1 Ranking by Evaluation Criteria

What is most striking about this ranking is that in general the vendor scores were quite similar. The functionality of the products is similar, but there are some variances in the execution. In general, however, all of these systems are capable of providing the basis for a fully featured DCS.

Vendor	Score
Altair Aerospace Corporation	88.25
EHS	85
L3 Communications/ Storm Integration	81
Integral Systems	78.75
Veda Systems	77.25
Software Technology	73.25
Command and Control Technologies	60

7.3.2 Ranking by Cost

Cost rankings for these systems are based on the commercial list prices given by the vendors. In all cases they clearly indicated that the prices given do not reflect any kind of negotiated discounts, and the final price for an operational system could vary quite substantially from this list. Additionally, several assumptions were made in trying to make these costs as comparable as possible, and these could significantly change the expected costs. With the exceptions noted in the comments the costing is based on software only costs. The reason for this is that all of the commercial systems can function with essentially any appropriate hardware configuration. This open system aspect of the solutions presented is very attractive, and allows the customer to mix and

match hardware solutions.

It should be noted that the expected hardware and software costs for the DCS fit well within the cost goals stated in the Ground System Requirements Document. One exception to this is in the area of maintenance. It appears that the maintenance costs are likely to be lower in most cases than was earlier estimated. As might be expected the lowest cost solutions presented will probably take more effort to develop vehicle unique applications, and the higher cost products will generally provide a much easier development environment. Each of the vendors offers a range of services to assist the customer in integration of the products into final form, but they are all committed to developing the expertise in the customer organization rather than building up a dependent relationship.

The technical expertise of the personnel at each of the evaluated organizations was impressive. In all cases these are the kind of small, highly competent organizations which are very responsive to requests for technical assistance. When you call the help line you will talk directly to one of the developers who is very familiar with the product.

Vendor	Cost	Comments
Veda Systems	48,000	This cost includes a significant portion of the telemetry hardware, based on an NT platform
Altair Aerospace Corporation	70,000	Software only
Software Technology	70,250	Software only
L3 Communications/ Storm Integration	113,235	Software only (includes G2)
Integral Systems	115,000	Software only
Command and Control Technologies	Less than 100,000	Costing is an estimate only, commercial price list not currently available
EHS	500,000	This is a fully installed cost including hardware, software and training.

8.0 Test Plan

This test plan presents a top level description of what will be tested in verifying and certifying the Data and Commanding System, and it includes a description of the internal and external interfaces that will be exercised. This activity is considered as critical to Bantam mission success since the majority of Bantam systems, both ground systems and flight systems, will be monitored and controlled via the DCS. This plan focuses on the processes involved and emphasizes consistency with the Program goal of defining an overall Bantam launch system which can be efficiently operated while delivering high reliability.

In the following sections we first briefly discuss the overall approach to testing including the organizational and configuration management aspects. This discussion is intended to establish a management framework within which the overall Bantam Program goals are supported by quality assurance/testing. Next an overall view of the various automated systems which support the Bantam launch vehicle and payload operations is introduced. This discussion emphasizes the need for compatibility among the component functional systems as a means of facilitating their testing and ultimate effective and efficient operation. This is followed by a discussion which focuses on DCS testing within the framework of the overall environment. Finally, we briefly describe using the DCS as a tool for facilitating end-to-end testing.

8.1 OVERALL

It is assumed that the launch vehicle developer/operator will define an organization which will facilitate developing and then operating the Bantam vehicle in a highly efficient and reliable manner. This organization will include quality/reliability assurance features which provide at least virtual separation between elements which physically develop or change configurations and the element which operates the vehicle and supporting systems. Reference Exhibit 8.1-1. This separation enables an ongoing check and balance environment wherein developers are required to document their work and train the operations personnel well enough for operations people to be able to operate and maintain what is developed. This provides insurance

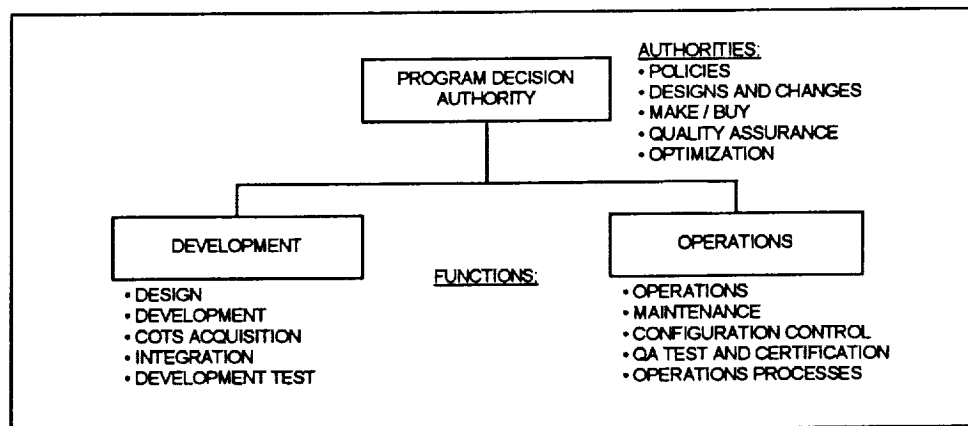

Exhibit 8.1-1 - Organization

that the developers will not evolve as the single points of failure for both the development *and* the operations functions. It provides a natural structure for implementing effective configuration management discipline by requiring a handover of what is developed from the development element to the operations element. It separates the development function from the test function, thus

enabling meaningful certification of mission readiness. And, it separates the developers from the operational system, thus curtailing the tendency to engineer and re-engineer the systems for an extended period. Finally, it provides management with a mechanism to control the ultimate cost of the systems developed; when the requirements are satisfied, development stops.

Note 1. Since the knowledgeable launch crew is assumed to be small, the untimely loss of even one person from it could present a risk to the overall capability to reliably launch on schedule. By ensuring adequate configuration/procedure documentation, effective configuration management and training/cross-training, the risk of attrition can be substantially mitigated.

Note 2. Computer systems are highly susceptible to extended periods of "re-engineering" since the technology changes rapidly and few developers prefer to work with "old technology". The tendency is to try to update/upgrade at a pace which keeps up with the latest and greatest. Considering the cost constraints imposed by the Bantam goals, such extended "development" is simply not affordable.

An overall view of the various automated systems which support the Bantam launch vehicle and payload operations is illustrated in Exhibit 8.1-2. In short: the Mission Planning System (MPS) sets up the DCS and the flight computer for the mission; the Simulator (SIM) provides the ability to test the flight computer/systems and the DCS in an off-line fashion; the on-board flight computer (OBC) provides vehicle guidance, navigation and control; and the DCS provides the launch crew with the ability to test, monitor and control operations throughout the mission life cycle.

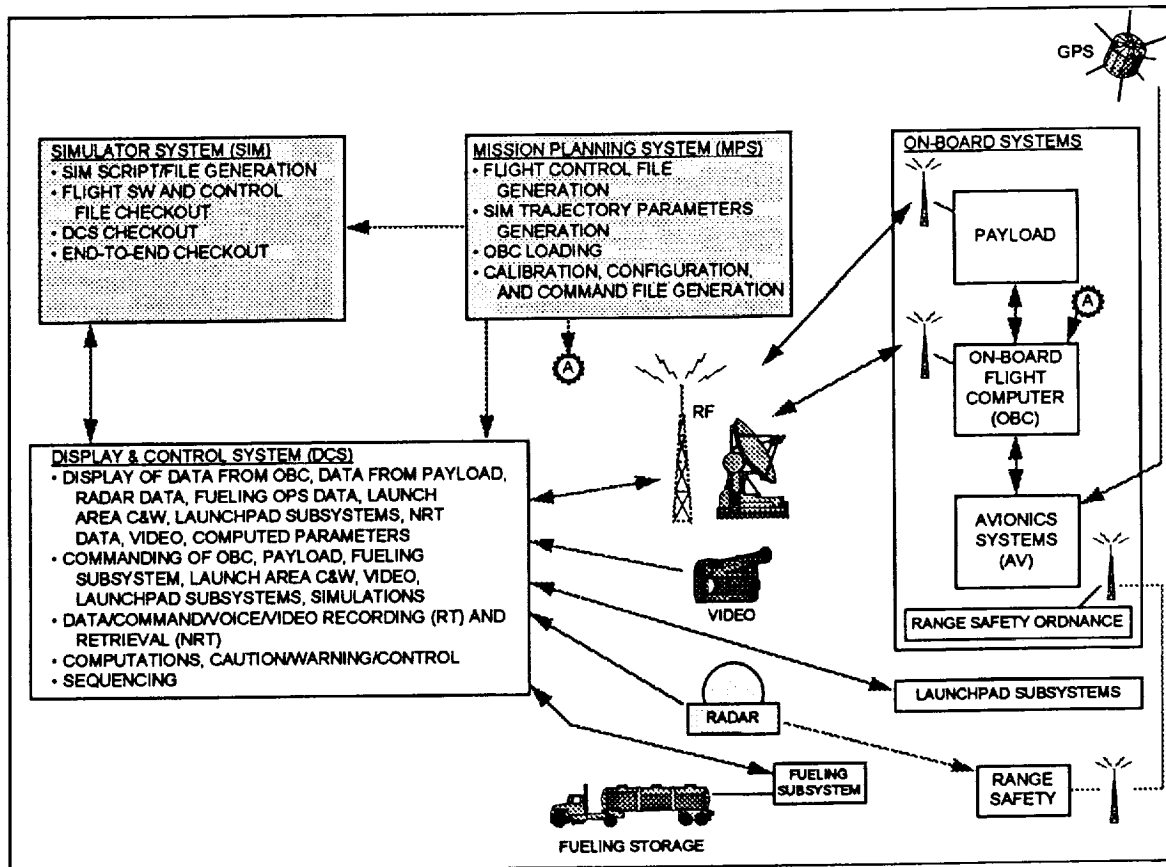

Exhibit 8.1-2 - Automated Systems Overview

The various functions of major Bantam data/commanding components are also shown in this exhibit. (Note, the functions related to building of the transducer calibration database, telemetry configuration database and command/script database are shown as within the Mission Planning System. Depending on the DCS selected, these functions may be included in the DCS.)

These systems include a diversity of real-time and non-real-time processing, processing which can be accomplished with off-the-shelf hardware/software, processing which is unique to the vehicle and the potential for the use of a wide variety of communications media. Some systems are directly involved launch support (unshaded), and some are involved only during launch preparation (shaded). This diversity coupled with the overarching requirements for low overall cost and high reliability provide an imperative for a sound system engineering approach to overall system design and selection. This approach must be implemented as early as possible in the process of designing/selecting the automated support systems to ensure that the component systems will perform their designated functions as well as smoothly interact with other component systems. Some objectives of this approach are to achieve:

- simplicity of overall design,
- minimum diversity of internal and external interface types, (the optimum would be one type of interface, ex., TCP/IP)
- maximum use of interoperable off-the-shelf hardware and software,
- low overall cost, *Note, a solution for the DCS component which represents the least DCS cost may not lead to the least overall cost. If the DCS solution does not interface well with the other components, large expenditures may be required to integrate the total system.*
- allocation of functions among systems geared toward simplicity of operations.

All of these design/engineering objectives contribute to enhance overall system reliability, interoperability, maintainability and affordability, in addition to enhancing the testability of the overall system (including the DCS), as well.

8.2 DATA AND COMMAND SYSTEM

The organization of the personnel responsible for the DCS follows the fundamental groundrules of the overall organization which was discussed above. That is, the development and configuration change functions are separated from the operations functions to mitigate the risks involved in lack of configuration management discipline. The overall organization is headed by an individual with the designated authority to approve or disapprove configuration changes. This DCS organization is as illustrated in Exhibit 8.2-1.

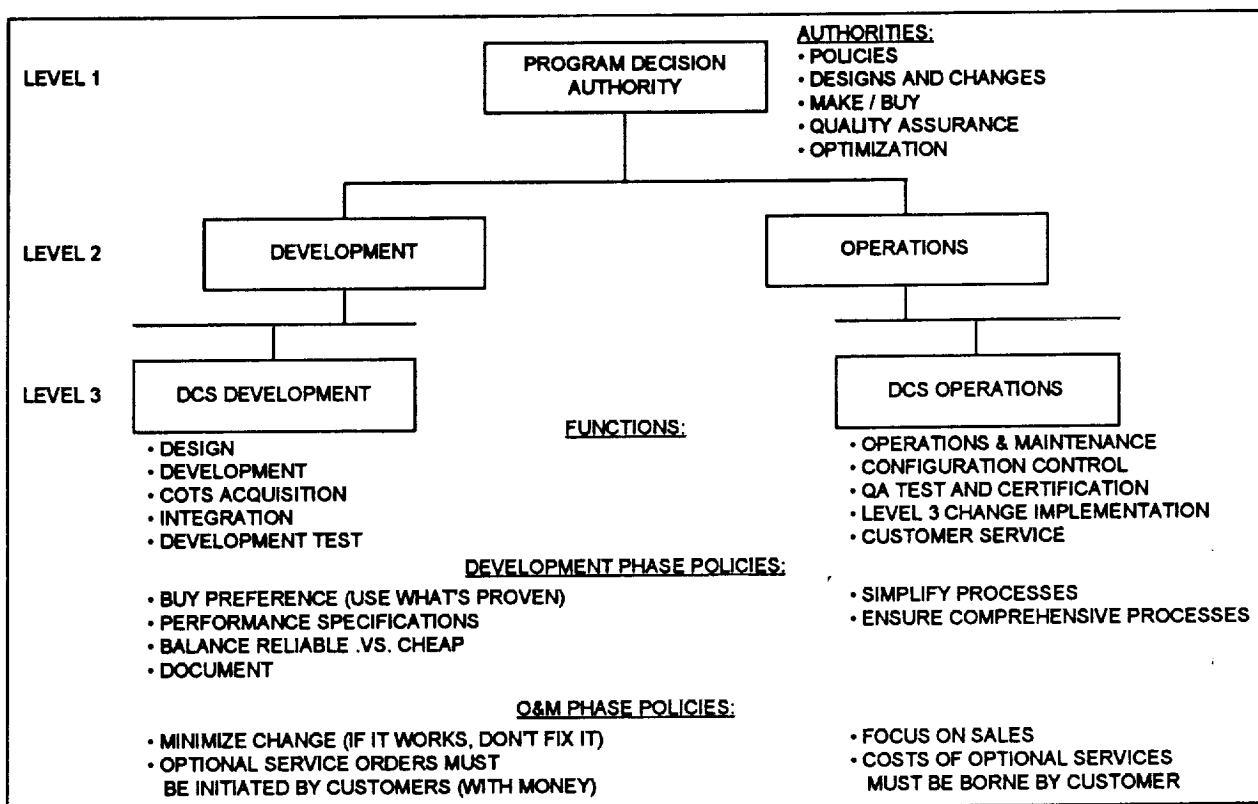

Exhibit 8.2-1 - DCS Organization

During the Bantam development phase it is likely that developers will perform in the role of DCS operators for functions such as using the DCS as a monitor and control device for vehicle systems tests on the factory floor. Such utilization is natural and assists in debugging and optimizing the DCS and providing valuable training on DCS utilization as well. However, it should be considered that good developers normally tend to stay in the development professions. It is rare that a good developer will transition into an operations job wherein his/her development skills will fade quickly. Thus, it is recommended that personnel who will perform the long term operations functions be assigned to operate the DCS at the earliest practical time in the development phase. This early assignment will also facilitate the production of DCS process/utilization documentation which will be needed for eventual system testing and certification. Such documentation is not really needed by developers (since they built it, they certainly know how to operate it), but it is essential to operators (they did not build it, but get stuck with operating it reliably).

In the real world the DCS development and operational phases will tend to overlap. The DCS will evolve through several versions prior to its first utilization for flight support. Hardware, op-

erating system and application software changes will be executed with only cursory management visibility. The developers will be empowered to do what has to be done to achieve a system which meets those requirements which are documented for the DCS and associated operational procedures. This activity will inherently include the DCS internal testing which will ultimately result in DCS functionality. At some point in this evolution, formalized testing of the DCS must be initiated and the system must be placed under configuration management (CM) control. Once placed under CM control, changes to the DCS should be curtailed to only those approved by the Program Decision Authority of Exhibit 8.2-1. Once placed under CM control, the entire testing process described in the following paragraphs should be required after each DCS change. *Note, this is probably the only way to stabilize the DCS and to stem its cost. It is certainly the only way for management to be assured that the DCS is ready for support.*

The process for formally testing the DCS and placing/maintaining it under CM control is illustrated in Exhibit 8.2-2.

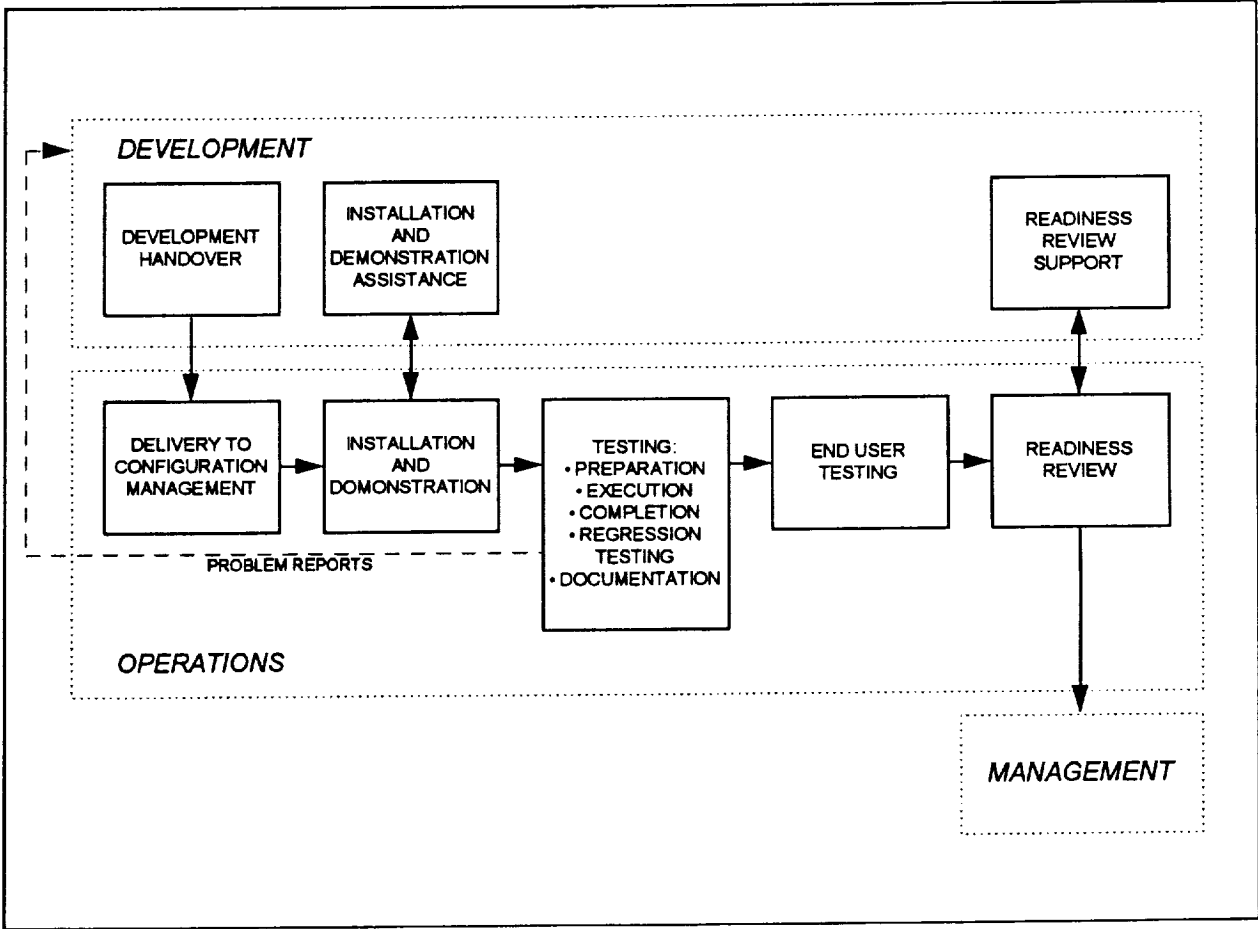

Exhibit 8.2-2 - DCS Test Process

The following paragraphs discuss the steps of this process.

8.2.1 Delivery to Configuration Management

Prior to the use of the DCS to support any substantial vehicle component, vehicle or payload test, the DCS itself should be tested and certified as operationally accurate and reliable. The first step in this testing process is to compile a comprehensive set of the as-built system and procedure documentation and transfer "ownership" of this documentation to operations. In addition, it is necessary for the developers to recognize that any contemplated changes to the system subsequent to this point shall be subject to authorization by the Program Decision Authority. In addition, all changes should be documented/rationalized in the Ground System Requirements Document and/or the Operations Concept and Plan. An individual within the operations organization, who is recognized as the controller of the configuration, should receive and retain this documentation. This "operations controller" should ensure thereafter that only authorized changes are made to the physical DCS configuration, that all changes are adequately reflected in the documentation and that a log of the changes be maintained.

The documentation to be controlled includes: the Ground System Requirements Document, the Operations Concept and Plan, operating system revision level descriptions; application revision level descriptions; hardware models/versions descriptions; interface and connectivity layouts; maintenance procedures; operations procedures and calibration, configuration and command file version descriptions. *The objective of this documentation and of keeping a record of changes to it is to ensure that any specific configuration can be reconstructed in case of an anomaly.*

The physical system to be controlled includes: all DCS hardware components, all internal interfaces and connections, all DCS software components, calibration files, telemetry configuration files, command files and test scripts. *Note, in the real world last minute low level changes may occur which require minor changes to the DCS. (For example, a last minute change-out of an on-board transducer could require a change to the calibrations database file.) In these cases, good sense dictates that the change must be made for expediency's sake and potentially without the benefit of exhaustive system retesting. The important point is that all such changes be brought to the attention of someone who realizes the potential ramifications of the change, prior to making the change, and that this person decides on any retesting requirements prior to continuation of the activity at hand. Referencing Exhibit 8.2-1, Level 2 leadership should agree on the handling of all changes, while Level 1 leadership should authorize any last minute change which could conceivably compromise property, safety, etc.*

8.2.2 Installation

The operations controller is responsible for DCS hardware and software installation - in accordance with the specific configuration documentation. He/she (and other operations personnel) may accomplish this by watching/assisting the developer(s) actually to perform the installation. *The operations controller is delegated this installation responsibility to ensure that someone other than the developers knows how to do it. This mitigates the risk of dependence on the developer as a single point of failure.*

8.2.3 Testing

This testing is to ensure that the DCS itself and the operational procedures perform as needed and that they are reliable for the conduct of vehicle component, vehicle and payload testing and mis-

sion operations. Testing is in “black box mode”. That is, testing is against the functional requirements of the system and procedures, not the internal designs thereof.

Testing is done by the operations team which may be comprised of multiple entities (ex. developers and operators) under the direction and leadership of the operations controller.

The objectives of the testing are:

- To validate that the requirements of the Bantam System Technology - Ground System Requirements Document have been implemented successfully *Note, each of the capabilities of the DCS and procedures should be directly traceable to the requirements document and/or the operations concept and plan. The paradigm should be that if there is no documented requirement, the capability is unneeded and unaffordable.*
- To validate that the requirements of the Bantam System Technology - Operations Concept and Plan have been implemented successfully
- To validate that the DCS internal and external interfaces are functional
- To validate and certify correct implementation of the documented hardware and software configurations.

The elements involved in testing/certifying that the DCS internal processes function as required are illustrated in Exhibit 8.2-3.

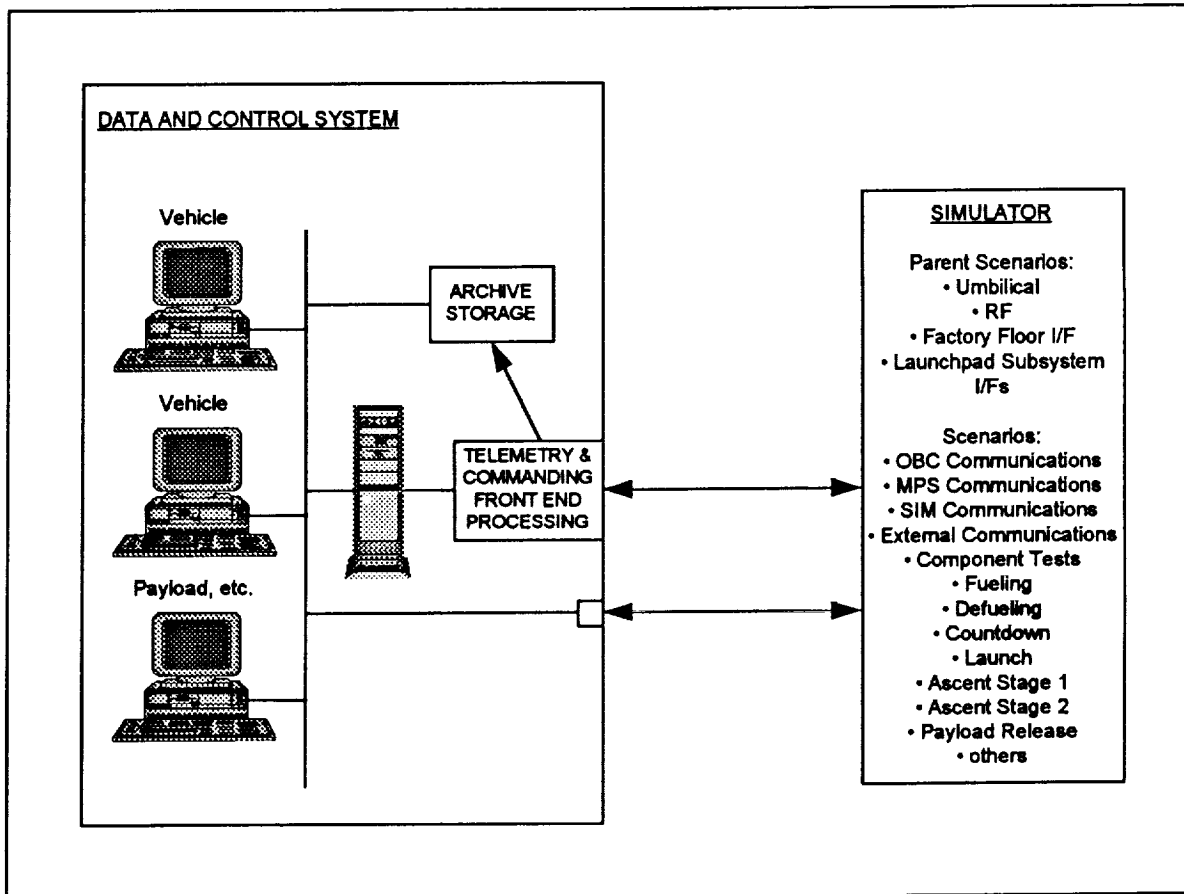

Exhibit 8.2-3 - DCS Test Configuration

Note, the simulator shown in this exhibit is a subset of the “simulation” discussed elsewhere in this document. The simulator used for DCS testing/certification is a data stream generator which produces known values for all of the data parameters passed over all of the interfaces into the DCS. In addition, this simulator provides the capability to ensure accurate receipt and analysis of DCS-generated commands. It is highly advisable to ensure that the DCS is capable of performing all of its functions in this isolated/off-line environment prior to testing the DCS with other ground system components. *Since simulators are quite expensive to develop, this is an important reason to acquire a DCS which is proven and off-the-shelf and which has a proven simulator package available.*

The ultimate DCS test configuration is shown in Exhibit 8.2-4 wherein all of the external interfaces are exercised.

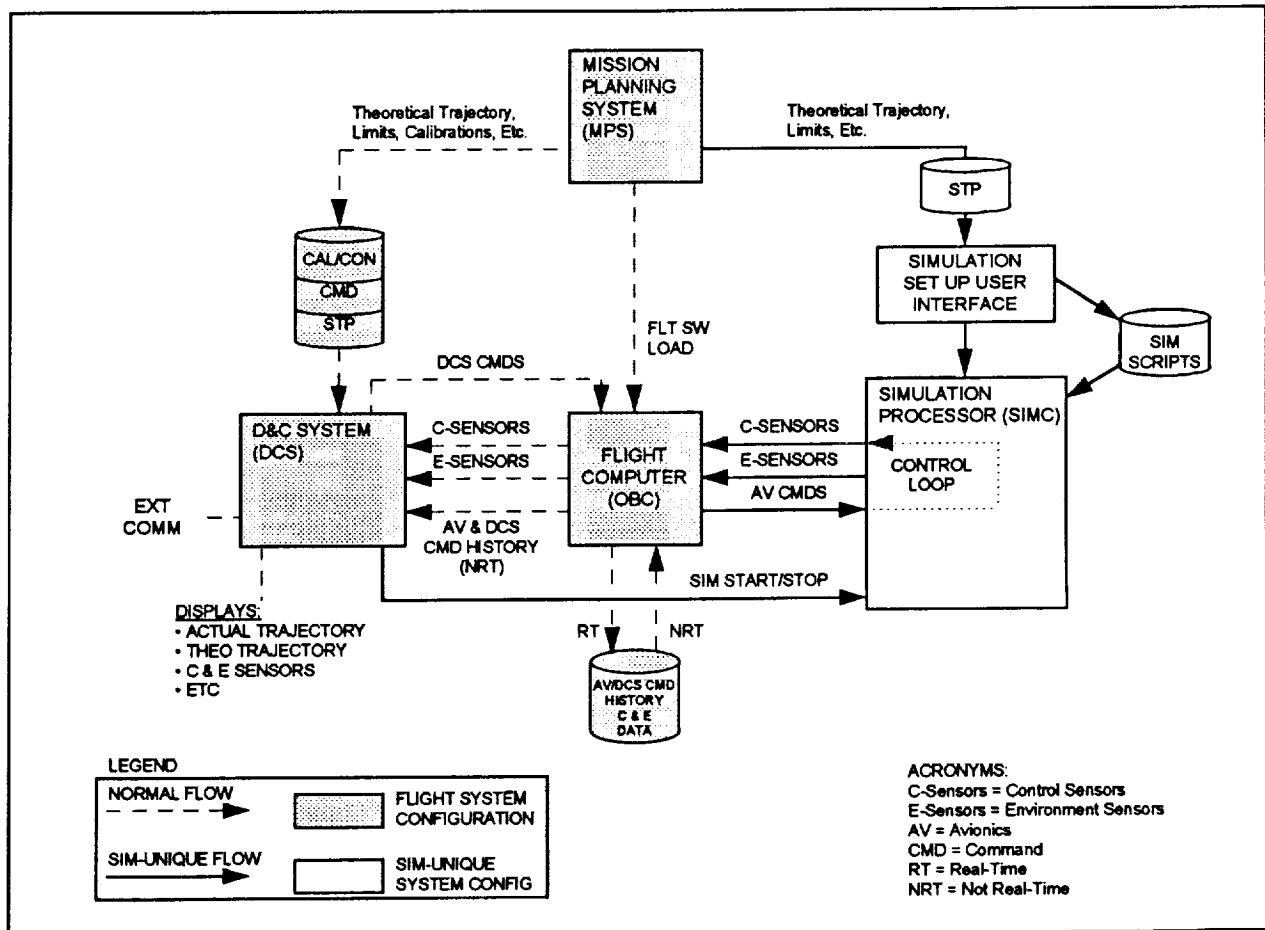

Exhibit 8.2-4 - Integrated Test Configuration

This configuration defines the setup of a typical *simulation* as defined elsewhere in this document, and it reflects the flight/mission support configuration as well. This configuration provides opportunities for testing of all of the DCS and procedure capabilities. *Note that by including the actual flight computer as part of the simulation component of the Ground System, it removes the guesswork from testing/simulating the DCS-OBC interface. This is as opposed to emulating the OBC within the simulation.*

8.2.3.1 Preparation

The testing is conducted using scripts developed to ensure that each requirement of the Bantam System Technology - Ground System Requirements Document have been implemented successfully. In addition, these scripts are to ensure that the DCS functionalities required in the Bantam System Technology Project, Ground System Operations Concept and Plan have been implemented. These scripts are developed, reviewed, and baselined prior to the test phase. (Test script formats are available in HOSE-SYS-121.) Test scripts tend to evolve more fully during the actual testing. A review of test scripts prior to the actual testing should ensure that all appropriate scenarios are tested, in addition to validating that script steps are correct.

The operations controller is responsible for verifying that the physical configuration of the hardware, software, databases, simulator, test scripts and communications matches the documented configuration. This can be practically accomplished during installation.

Having verified that the physical and documented configurations are the same, the operations controller certifies the configuration in writing. (Forms for this certification are available in HOSE-SYS-121.)

8.2.3.2 Execution

The testing involves the target DCS hardware and software. (Target-like hardware and/or software can be used for demonstrations, but not for DCS certification.) Input data for validation of the functionality of the DCS is generated by the Simulator. Calibration, telemetry configuration and command database information originates from either a test database or an actual mission database.

The test team executes tests according to the appropriate scripts, testing as many steps as possible for each script even when problems are encountered. Problems are documented on Problem Reports which are reviewed by all appropriate management. Management retains the authority to determine whether a problem must be fixed or if a work-around will be adopted.

As each test script is executed, the test results are recorded in a test log. (Test log format is available in HOSE-SYS-121.) In general, this documentation includes test results such as screen dumps and reports, support documentation/comments and problem reports. These data are retained for future reference.

8.2.3.3 Completion

A review should be conducted to mark the end of a logical set of tests. The purpose of this review is to ensure that the test results are visible to the appropriate management, development personnel and operations personnel.

8.2.3.4 Regression Testing

When testing is the result of configuration changes which were triggered by Problem Reports, regression testing must be performed according to the criteria of Section 8.2.3.2. In this case, it is necessary also to ensure that all documentation is kept up-to-date by the methods described in Section 8.2.3.1.

8.2.3.5 Documentation

The aggregate of the documentation described in Sections 8.2.3.1 through 8.2.3.4 should be compiled and filed for future reference for each configuration tested. (This documentation constitutes the basis for DCS system certification.)

8.2.4 End User Testing

The testing described above is intended to ensure that the DCS meets or exceeds the requirements for primarily the monitoring and control of the launch vehicle. It is probable that Bantam customers (payload developers) may also have requirements for using the DCS to monitor and control some aspects of the payload. For this reason, it is recommended that a practical number of payload developers be invited to test the DCS as early as possible in the DCS development process. Such interaction with payload developers may well define additional DCS requirements as well as be a valuable marketing tool for Bantam launch services.

8.2.5 Readiness Review

A review should be conducted to mark the end of testing and to provide visibility of the readiness of the DCS to provide support for vehicle component, vehicle and payload test/mission activities. The purpose of this review is to ensure that the appropriate management, development personnel and operations personnel are aware of the successful conclusion of DCS testing as well as any work-arounds which have been implemented in response to problems encountered during testing. In addition, this review serves to reinforce the stability of the system by ensuring that all parties are aware that the system is in a fixed state of configuration control pending approval of the Program Decision Authority for any change.

9.0 Communications

The communications needed for conducting mission preparation and operations can be a substantial cost driver. However, by exploiting modern technology and by designing operational procedures to accommodate this technology, these costs can be held to an adequate minimum. This section presents a framework for designing/specifying the ground systems (as well as flight systems) to accomplish efficient communications throughout the mission life cycle. Alternatives are presented for specific implementation cost / performance optimization.

Typical activities which drive communications requirements for the various phases of the mission life cycle are shown in Exhibit 9.0-1. This exhibit also presents suggested communication media for accommodating the stated requirements as well as approximate costs which can be anticipated for the suggested approaches. The following paragraphs expand on these suggestions.

MISSION PHASE	TYPICAL ACTIVITY	COMM MEDIA	COST / COMMENT
MISSION PLANNING	<ul style="list-style-type: none"> • TRIAL RUNS OF MPS (FROM USER SITE) TO ENSURE BANTAM VEHICLE SUITED FOR PAYLOAD • ALL MISSION PLANNING AND SCHEDULING "PAPERWORK" 	INTERNET	<ul style="list-style-type: none"> • INTERNET COST NEGLIGIBLE • MPS INCLUDED IN BANTAM VEHICLE OPERATOR'S WEBSITE • "PAPERWORK" ALL VIA WEBSITE ELECTRONIC DATA EXCHANGE
INTEGRATION	<ul style="list-style-type: none"> • REMOTELY VIEW PHYSICAL INTEGRATION (VIDEO) • REMOTELY VIEW/ANALYZE PHYSICAL INTEGRATION DATA FROM DCS 	INTERNET OR DEDICATED CIRCUIT	<ul style="list-style-type: none"> • INTERNET DATA/VOICE/VIDEO INSTALLATION COSTS APPROX. \$1K • INTERNET OPERATIONS COST NEGLIGIBLE (STD BANDWIDTH) • DEDICATED CIRCUIT DATA, VOICE, VIDEO INSTALLATION COSTS ROM \$30K FOR FRAC T-1 • DEDICATED CIRCUIT COST APPROX \$1-2K PER MONTH FOR FRAC T-1
COUNTDOWN, LAUNCH AND ASCENT	<ul style="list-style-type: none"> • REMOTELY VIEW/ANALYZE PERFORMANCE DATA FROM DCS • REMOTELY VIEW OPERATIONS (VIDEO/VOICE) 		
ON-ORBIT OPERATIONS	<ul style="list-style-type: none"> • REMOTELY VIEW/ANALYZE PERFORMANCE DATA FROM SPACECRAFT • REMOTELY COMMAND SPACECRAFT 	TDRSS OR PRIVATE DISH FOR SPACE TO GROUND LINKS	<ul style="list-style-type: none"> • TDRSS: INSTALLATION ROM \$0, DOWNLINK APPROX \$13/MIN, UPLINK APPROX \$26-39/MIN • PRIVATE DISH: INSTALLATION ROM \$10K AND NEAR \$0 PER MONTH
	<ul style="list-style-type: none"> • DISTRIBUTE DATA TO/FROM REMOTE SITES • COMPILE COMMANDS FOR UPLINK 	INTERNET FOR GROUND TO GROUND LINKS	<ul style="list-style-type: none"> • INTERNET INSTALLATION AND OPERATIONS COSTS NEGLIGIBLE (STD BANDWIDTH)

Exhibit 9.0-1 - Mission Life Cycle Communications

Mission Planning Phase - The primary activities of this phase are: (1) assuring the prospective payload customer that the Bantam vehicle is suitable for his/her payload and (2) exchanging technical and management information relative to scheduling, interfacing, cost, constraints, spaceports and the like. The vast majority of this information is suitable for exchange via the Internet - with proper security precaution. For example, the vehicle operator's website would do well to include information which provides guidance on how the prospective customer can engage the vehicle operator for providing launch services. The Mission Planning System module for calculating/displaying vehicle performance based on payload and orbital parameters could be accessible via the website to allow customers to satisfy themselves of Bantam suitability without intensive vehicle operator personnel involvement. All of the necessary forms ("paperwork") associated with launch permits, analytical integration, etc. should be completed in the paperless on-line environment. Since virtually every prospective Bantam customer will have Internet access, the implementation cost for the customer is considered to be zero. The cost for the vehicle operator to implement the website capabilities described is estimated at around \$10K.

Integration Phase - The primary activities of this phase are: (1) transport of the payload to the launch site, (2) physical integration of the payload and vehicle, (3) testing to ensure that interfaces (mechanical, electrical and electronic) are functional and (4) testing to ensure the launch readiness

of the vehicle and payload. Transport of the payload can be facilitated/tracked using the information exchange capabilities of the Internet. Physical integration is often video monitored and recorded. Should the payload developer or some key personnel of the vehicle developer be located at a site remote from the integration site but wish to "witness" the integration or help in troubleshooting, video could be made available at the remote site. Internet-based video can be implemented for under \$2K. If full motion video is desired, the equipment needed can be purchased for around \$20K; this same equipment could be rented/leased for a small fraction of this cost. In addition, full motion dedicated circuit costs can be expected to include approximately \$4K for circuit setup (both ends) and up to \$2K per month if continuous service is desired.

Integration testing frequently involves data acquisition at the integration site - performed by the DCS. If this data is required to be monitored in real-time by personnel at a remote site(s), both Internet-based and dedicated circuit communications solutions are readily available. The majority of the DCS systems surveyed support this remote monitoring via the Internet for an additional DCS cost of around \$2K. In this case communications costs are negligible. If data refresh rate and/or data timeliness is a substantial issue, dedicated circuit services may be acquired. In the worst case (considering that both full motion video and data are desired), additional equipment purchase costs of around \$10K can be expected. (This \$10K cost can be avoided if video or other multiple channel requirements do not exist.) Dedicated data circuit setup costs (without video) are about \$1K with recurring costs of about \$300 per month (continuous service). Standard telephone service is suggested for remote voice requirements.

Countdown, Launch and Ascent Phase - The primary activities of this phase are: (1) prelaunch testing of the integrated vehicle and payload, (2) preparing the vehicle for launch (fueling, etc.), (3) monitoring preparations for launch via the DCS, voice and video, (4) initiating the launch sequence via the DCS and (5) monitoring ascent via the DCS and video. Launch site communications are considered to be self contained within the launch site systems. If the DCS data monitoring activities or video monitoring activities are desired to be observed from a site remote from the launch site, the remote communications options discussed above apply. Standard telephone service is suggested for remote voice requirements.

On-Orbit Operations Phase - The primary activities of this phase are highly payload dependent. However, if there are requirements for data (or video) downlink and/or command/data uplink, several options are available currently and more options may be available in the future. NASA can provide downlink and uplink services using the Tracking and Data Relay Satellite System (TDRSS) for the prices shown in Exhibit 9.0-1. These services are managed using a demand access approach wherein the communications must be precoordinated and the TDRSS capabilities are utilized on a first come first served basis. Single access services may be available through the TDRSS for costs of \$90 - \$180 per minute. This approach requires substantial upfront planning during the payload design and development phases and close coordination with the NASA Goddard Space Flight Center during these phases is suggested.

Private downlink/uplink communications can be established using equipment costing from \$10K and up. This includes use of a private dish and an operations procedure wherein the orbiting payload dumps/uploads data as it passes over the dish. Again, this approach requires substantial upfront planning during the payload design and development phases but its recurring communications costs can be nearly zero.

Although commercial, space-based communications service providers are currently focused on the terrestrial communications market, satellite to satellite relay services are maturing and should be available from a larger number of sources in the future. Most of the technologies needed for such services exist and activities are in motion to mitigate current regulatory restrictions.

The communications ground segments of most on-orbit payload operations scenarios can be accomplished utilizing the current Internet. And, since the Internet is so universally established and since tools for its usage are so extensive (and inexpensive), it is recommended that all payloads and ground support schemes be designed to exploit Internet usage. In the future, the bandwidth capability of the Internet will be upgraded with the introduction of the Internet II, and Internet II will most likely be made available for science support as a priority. In those cases where data rates practically exceed the effective standard Internet capability, dedicated circuits can be obtained for costs as estimated above. (Note, cost is directly proportional to bandwidth.)

10.0 Conclusions

The following conclusions were drawn in the conduct of this study.

1. A fully functional Bantam DCS can be acquired from off-the-shelf products; expensive DCS development is unnecessary.
2. The cost goals of the Ground System Requirements Document relative to the development phase can be achieved. The cost goals relative to the operations phase can be easily achieved.
3. All of the systems surveyed can meet the pass-fail criteria described in Section 7.1.1.

11.0 Recommendations

This section presents recommendations derived in conducting the study. The “overall” recommendations are most appropriately considered as suggestions to NASA, while the “DCS” recommendations are primarily to the vehicle developers.

11.1 OVERALL

Recommendations relative to the overall Bantam Program are:

1. Consider developing a standard development flight instrumentation payload as a specification for the Bantam Cycle 2 competition. This may simplify the physical and electronic interfaces to which the launch vehicle developers are to build their vehicles, and it may in turn result in an overall Bantam Program cost avoidance.
2. Consider defining a standard DCS as a specification for the Bantam Cycle 2 competition. This may also simplify the interfaces to which the launch vehicle developers are to build their vehicles, it will reduce the redundancy of each vehicle working on his own DCS, and it may in turn also result in an overall Bantam Program cost avoidance.
3. Consider establishing a working group of representatives from the various Bantam contractors. The purpose of the working group would be to establish Bantam areas where design commonality can benefit all participants. For example, they should discuss a common basic vehicle to payload interface for the demonstration phase. This may result in an overall Ban-

tam Program cost avoidance by eliminating redundant work on such interfaces. A common interface for the operational phase may enhance the value of the vehicle to potential customers, since it allows them to develop payloads to a single standard without having to worry about what carrier they will be using. (This can also serve to spur price competition among the carriers.)

11.2 DATA AND COMMAND SYSTEM

Recommendations relative to the Bantam DCS are:

1. The vehicle developers should move quickly to select a ground system supplier/integrator and involve them in the preliminary design process. Many decisions which are made early in the design process could significantly lower ground system costs without significant effects on the final cost of the vehicle. It is clear that several off the shelf systems exist which can be implemented easily and will allow the operational goals of the ground system to be achieved.
2. The vehicle developers should adopt the paradigms suggested in the Principles Section (Section 3.1) of this document.

REPORT DOCUMENTATION PAGE

Form Approved
OMB No. 0704-0188

Public reporting burden for this collection of information is estimated to average 1 hour per response, including the time for reviewing instructions, searching existing data sources, gathering and maintaining the data needed, and completing and reviewing the collection of information. Send comments regarding this burden estimate or any other aspect of this collection of information, including suggestions for reducing this burden, to Washington Headquarters Services, Directorate for Information Operations and Reports, 1215 Jefferson Davis Highway, Suite 1204, Arlington, Va 22202-4302, and to the Office of Management and Budget, Paperwork Reduction Project (0704-0188), Washington, DC 20503.

1. AGENCY USE ONLY (Leave Blank)		2. REPORT DATE 19 February 1998	3. REPORT TYPE AND DATES COVERED Final: 19 Aug. 1997 to 19 Feb. 1998
4. TITLE AND SUBTITLE Bantam System Technology Project Final Report		5. FUNDING NUMBERS C-NAS8-97319	
6. AUTHOR(S) Jesse M. Moon James R. Beveridge			
7. PERFORMING ORGANIZATION NAME(S) AND ADDRESS(ES) New Technology, Inc. 700 Boulevard South, Suite 401 Huntsville, AL 35802-2176		8. PERFORMING ORGANIZATION REPORT NUMBERS FR1005	
8. SPONSORING/MONITORING AGENCY NAME(S) AND ADDRESS(ES) NASA/George C. Marshall Space Flight Center Advanced Space Transportation Program Office Marshall Space Flight Center, AL 35812		10. SPONSORING/MONITORING AGENCY REPORT NUMBER	
11. SUPPLEMENTARY NOTES			
12a. DISTRIBUTION/AVAILABILITY STATEMENT		12b. DISTRIBUTION CODE	
13. ABSTRACT (Maximum 200 words) This report focuses on determining a best value, low risk, low cost and highly reliable Data and Command System for support of the launch of low cost vehicles which are to carry small payloads into low earth orbit. The ground-based DCS is considered as a component of the overall ground and flight support system which includes the DCS, flight computer, mission planning system and simulator. Interfaces between the DCS and these other component systems are considered. Consideration is also given to the operational aspects of the mission and of the DCS selected. This project involved: defining requirements, defining an efficient operations concept, defining a DCS architecture which satisfies the requirements and concept, conducting a market survey of commercial and government off-the-shelf DCS candidate systems and rating the candidate systems against the requirements/concept. The primary conclusions are that several low cost, off-the-shelf DCS solutions exist and these can be employed to provide for very low cost operations and low recurring maintenance cost. The primary recommendation is that the DCS design/specification should be integrated within the ground and flight support system design as early as possible to ensure ease of interoperability and efficient allocation of automation functions among the component systems.			
14. SUBJECT TERMS Low Cost Booster Technology, Bantam, Launch System Operations Concept, Ground Support System		15. NUMBER OF PAGES 53	16. PRICE CODE N/A
17. SECURITY CLASSIFICATION UNCLASSIFIED	18. SECURITY CLASSIFICATION OF THIS PAGE UNCLASSIFIED	19. SECURITY CLASSIFICATION OF ABSTRACT UNCLASSIFIED	20. LIMITATION OF ABSTRACT UL