

NASA/CR- 95- 207566

COMPLETED
078031

OPTIMAL FULL INFORMATION SYNTHESIS FOR FLEXIBLE STRUCTURES IMPLEMENTED ON CRAY SUPERCOMPUTERS

Rick Lind¹
NASA - Dryden Flight Center

Gary J. Balas²
University of Minnesota

Abstract

This paper considers an algorithm for synthesis of optimal controllers for full information feedback. The synthesis procedure reduces to a single linear matrix inequality which may be solved via established convex optimization algorithms. The computational cost of the optimization is investigated. It is demonstrated the problem dimension and corresponding matrices can become large for practical engineering problems. This algorithm represents a process that is impractical for standard workstations for large order systems. A flexible structure is presented as a design example. Control synthesis requires several days on a workstation but may be solved in a reasonable amount of time using a Cray supercomputer.

Introduction

Flexible structures present interesting and difficult problems to control engineers. Lightweight structural elements give rise to lightly damped, often closely spaced natural frequencies. Linear, time-invariant mathematical models of these structures do not accurately represent the true system. Uncertainty is included to represent unmodeled dynamics and high frequency modes. Parametric uncertainty may also be included to represent unknown coefficients in the state-space models such as natural frequency and damping coefficients.

There are many control design techniques for synthesis of output feedback controllers of flexible structures. Controllers for the Middeck Active Control Experiment have been based on LQG and \mathcal{H}_2 theory along with an approach to maximum robustness to real uncertainty using

¹NRC PostDoctoral Research Fellow, Controls and Dynamics Branch, MS 4840D/RC, Edwards, CA 93523-0273, lind@xrd.drc.nasa.gov, Member AIAA

²Assistant Professor, Department of Aerospace Engineering, Minneapolis, MN 55455, balas@aem.umn.edu, Member AIAA

⁰Copyright ©1995 by the American Institute of Aeronautics and Astronautics, Inc. All rights reserved.

Popov multipliers [12]. \mathcal{H}_∞ and μ controllers are synthesized for the NASA - Langley Minimast Structure [4]. An approach to attenuate modal vibrations is researched using eigenstructure assignment to control the eigenvectors that determine mode shape [26].

Full information feedback is an optimal feedback configuration that provides direct measurements of all states and disturbances to the controller. Packard *et al* demonstrate optimal full information controllers may be computed to minimize a μ upper bound for systems with complex uncertainty [21, 22]. These results are extended to compute optimal full information controllers that directly account for additional information provided by purely real uncertainty in the synthesis algorithm [3].

The synthesis procedure involves the solution to a linear matrix inequality (LMI). LMI's have received a great deal of attention in recent systems and controls literature [1, 7, 8]. LMI minimization problems may be solved using standard convex optimization techniques. The Ellipsoid Method and the Method of Centers are readily suited to LMI optimization [7].

This paper considers the LMI minimization for synthesis of optimal full information controllers of a high order flexible structure. There are two main results presented.

- A globally optimal μ controller is synthesized for a flexible structure.
- Large dimension LMI optimization is solved on a Cray supercomputer.

Vibration attenuating controllers are computed for a flexible structure. It is desired to attenuate the response at 11 natural frequencies between 0 and 70 (*rad/sec*). The controllers must be robust to parametric uncertainty in the modal damping coefficients and input multiplicative uncertainty. A globally optimal full information controller is compared to an output feedback controller computed using *D-K* iteration. Standard workstations are impractical for the optimal controller synthesis for the full order model due to the large computational cost. A Cray supercomputer is able to compute the optimal controller in considerably less time using a vectorized algorithm.

Robustness with Real/Complex Uncertainty

Define $x \in \mathbb{R}^{n_s}$ as the vector of states, $z \in \mathbb{R}^{n_e}$ as the vector of errors, $y \in \mathbb{R}^{n_y}$ as the vector of measurements, $d \in \mathbb{R}^{n_d}$ as the vector of disturbances and $u \in \mathbb{R}^{n_u}$ as the vector of control inputs. The state-space description of a linear time-invariant plant can be represented as

$$\begin{bmatrix} \dot{x} \\ z \\ y \end{bmatrix} = \begin{bmatrix} A & B_1 & B_2 \\ C_1 & E_{11} & E_{12} \\ C_2 & E_{21} & E_{22} \end{bmatrix} \begin{bmatrix} x \\ d \\ u \end{bmatrix}$$

where $A \in \mathbb{R}^{n_s \times n_s}$, $B_1 \in \mathbb{R}^{n_s \times n_u}$, $B_2 \in \mathbb{R}^{n_s \times n_d}$, $C_1 \in \mathbb{R}^{n_e \times n_s}$, $C_2 \in \mathbb{R}^{n_y \times n_s}$, and the E matrices of appropriate dimensions.

Define P as the Laplace transform of this system,

$$P(s) = \begin{bmatrix} P_{11}(s) & P_{12}(s) \\ P_{21}(s) & P_{22}(s) \end{bmatrix} = \begin{bmatrix} E_{11} & E_{12} \\ E_{21} & E_{22} \end{bmatrix} + \begin{bmatrix} C_1 \\ C_2 \end{bmatrix} (sI - A)^{-1} \begin{bmatrix} B_1 & B_2 \end{bmatrix}$$

Define $S(P)$ as the set of all real, rational, proper controllers, $K(s)$, which stabilize the closed-loop system. Introducing a controller into the system leads to the following linear fractional transformation (LFT).

$$F_l(P, K) = P_{11} + P_{12}K(I - P_{22}K)^{-1}P_{21}$$

This LFT represents the closed-loop transfer function with the lower loop of P closed with the controller K . Analyzing performance using the infinity norm leads to the following minimization problem.

$$\inf_{K \in S(P)} \|F_l(P, K)\|_\infty$$

This is an \mathcal{H}_∞ optimal controller synthesis problem which has been solved using state-space equations [9, 11].

The structured singular value, μ , can be used to determine robustness of the closed-loop system to structured modeling uncertainty and the achievable performance level in the presence of uncertainty. The uncertainty is allowed to include both complex and real parametric uncertainty.

The uncertainty description is structured with two types of blocks. The blocks are repeated scalar or full block matrices. Let integers m, n, p define the number of real scalar, complex scalar, and complex full blocks. Define integers R_1, \dots, R_m such that the i^{th} repeated scalar block of real parametric uncertainty is of dimension $R_i \times R_i$. Define similar integers C_1, \dots, C_n to denote the dimension of the complex repeated scalar blocks. The structured uncertainty description Δ is assumed to be norm bounded and belonging to the following set.

$$\Delta = \{ \text{diag} (\delta_1^R I_{R_1}, \dots, \delta_m^R I_{R_m}, \delta_1^C I_{C_1}, \dots, \delta_n^C I_{C_n}, \Delta_1, \dots, \Delta_p) : \delta_i^R \in \mathbb{R}, \delta_i^C \in \mathbb{C}, \Delta_i \in \mathbb{C}^{c_i \times c_i} \}$$

Real parametric uncertainty is allowed to enter the problem as scalar or repeated scalar blocks. Complex uncertainty enters the problem as scalar, repeated scalar or full blocks.

The function μ is defined as

$$\mu_\Delta(M) = \frac{1}{\min_{\Delta} \{ \bar{\sigma}(\Delta) : \det(I - M\Delta) = 0 \}}$$

The value of μ depends on the block structure of Δ . Upper and lower bounds for μ have been derived which utilize two sets of structured scaling matrices. These scaling matrices are similar in structure to the uncertainty block structure.

$$\mathcal{D} = \{ D = D^* = \text{diag} (D_1^R \dots D_m^R D_1^C \dots D_n^C d_1^c \dots d_p^c) : D_i^R \in \mathbb{C}^{R_i \times R_i}, D_i^C \in \mathbb{C}^{C_i \times C_i}, d_i \in \mathbb{C} \}$$

The set of scalings \mathcal{G} affect only the real parametric uncertainty blocks.

$$\mathcal{G} = \{ G = G^* = \text{diag} (G_1 \dots G_m 0 \dots 0) : G_i \in \mathbb{C}^{R_i \times R_i} \}$$

Define an upper bound for real/complex μ [10, 27].

$$\mu(M) \leq \inf_{\substack{D \in \mathcal{D} \\ G \in \mathcal{G}}} \bar{\sigma} \left((DM D^{-1} + jG) (I + G^2)^{\frac{1}{2}} \right)$$

The structured singular value provides a measure of robustness in the presence of the defined structured uncertainty. The \mathcal{D} and \mathcal{G} matrices are allowed to vary with frequency for linear, time-invariant (LTI) uncertainty. These scalings are restricted to be constant when computing robustness in the presence of linear time-varying (LTV) uncertainty [24].

The objective of control design is to maximize robust performance which corresponds to minimizing μ in this framework. An approach to output feedback control design which minimizes complex μ is called $D - K$ iteration. This technique is used to synthesize output feedback controllers for the flexible structure example. $D - K$ iteration tries to achieve the desired robust performance objectives by integrating \mathcal{H}_∞ control design with complex μ analysis [2, 9, 19]. $D - K$ iteration alternately minimizes the complex μ upper bound with respect to K or D holding the other variable constant. This technique has been applied with great success to a variety of aerospace applications despite a lack of guarantee to reach the global optimum [2, 14, 23]. A more detailed discussion of $D - K$ iteration can be found in References [2, 20]. An approach to minimizing the μ upper bound for the full information case is presented in the following section.

Optimal Full Information Controllers

An algorithm to compute the optimally scaled, \mathcal{H}_∞ full information (FI) controller for a system with linear, time-varying (LTV) uncertainty is presented by Packard *et al* [21, 22]. This algorithm considers the synthesis problem with constant \mathcal{D} scalings included to allow infinitely fast time variation in the complex uncertainty. This section outlines this synthesis procedure and presents the main theorem given in Reference [21].

The open-loop system considered is a continuous-time plant. The controller is provided with direct measurement of the states and disturbances and is called the full information plant. Define P_{fi} as the full information plant.

$$P_{fi} = \left[\begin{array}{c|cc} A & B_1 & B_2 \\ \hline C_1 & E_{11} & E_{12} \\ I & 0 & 0 \\ 0 & I & 0 \end{array} \right]$$

The closed-loop \mathcal{H}_∞ norm condition is shown to be equivalent to a maximum singular value condition involving the constant matrix form of the discretized full information plant. The following theorem demonstrates this equivalency [21].

Theorem 0.1 *Given the full information plant, $P_{fi}(s)$, and the constant matrix discrete-time plant, \hat{P}_{fi} , along with the set \mathcal{D} of scaling matrices, then the following are equivalent.*

1. There exists $D \in \mathcal{D}$ and stabilizing K such that

$$\|D^{\frac{1}{2}} F_l(P_{fi}(s), K) D^{-\frac{1}{2}}\|_\infty < 1$$

2. There exists $D \in \mathcal{D}$ and stabilizing K along with real $X = X^T > 0$ such that with $Z = \text{diag}(X, D)$.

$$\bar{\sigma} \left(Z^{\frac{1}{2}} F_l(\hat{P}_{fi}, K) Z^{-\frac{1}{2}} \right) < 1$$

The resulting constant matrix problem has two scaling matrices, D and X . D is the original constant matrix that scales the plant inputs and outputs. X is the symmetric positive definite solution matrix in the Riccati formulation of the \mathcal{H}_∞ problem. It scales the inputs and outputs of the discrete-time state equation. The X matrix is included in the singular value test to restrict the eigenvalues of the discrete-time state matrix to be less than one to guarantee stability.

Now perform a change of variables. Denote the entries of the discrete-time plant as $\{R, U, V, T\}$ and introduce Q to replace $K(I + TK)^{-1}$ in the closed-loop LFT for notational convenience.

$$F_l(\hat{P}_{fi}, K) = R + UK(I + TK)^{-1}V = R + UQV$$

A variant of Parrott's theorem is used to formulate two maximum eigenvalue conditions equivalent to the constant matrix singular value condition introduced in Theorem 0.1. The resulting eigenvalue condition is presented in Lemma 0.2.

Lemma 0.2 *Given the discrete-time plant, \hat{P}_{fi} , formulate the closed-loop LFT as $F_l(\hat{P}_{fi}, K) = R + UQV$ and define U_\perp such that $[U \ U_\perp]$ is invertible and $U^T U_\perp = 0$. Then*

$$\inf_{\substack{Q \in \mathcal{S}(\mathcal{P}) \\ Z \in \mathcal{Z}}} \bar{\sigma} \left(Z^{\frac{1}{2}} (R + UQV) Z^{-\frac{1}{2}} \right) < 1$$

if and only if there exists $Z \in \mathcal{Z}$ such that

$$\bar{\lambda} (U_\perp^T (RZ^{-1}R^T - Z^{-1})U_\perp) < 0$$

The proof follows directly from Parrott's theorem [16, 21]. There is an additional eigenvalue condition involving the matrix V and a perpendicular component V_\perp defined similar to U_\perp . The V matrix in the LFT of the closed-loop system with the full information plant is square and invertible so V_\perp is null. The maximum eigenvalue condition utilizing this variable is automatically satisfied. The remaining maximum eigenvalue condition is a linear matrix inequality (LMI) with the scaling matrix as the free parameter.

The \mathcal{H}_∞ synthesis problem for the continuous-time full information system is thus reduced to a single constant matrix maximum eigenvalue problem using elements of the discrete-time full information system. The following theorem summarizes the synthesis procedure for systems with infinitely fast varying LTV structured, complex uncertainty [21, 22].

Theorem 0.3 *Given n_s -state full information plant, P_{fi} , and the set \mathcal{D} , define the following.*

1. the augmented scaling matrices \mathcal{Z}

$$\mathcal{Z} = \left\{ \left[\begin{array}{cc} X & 0 \\ 0 & D \end{array} \right] : \begin{array}{l} X \in \mathbb{R}^{n_s \times n_s}, X = X^T > 0 \\ D \in \mathcal{D} \end{array} \right\}$$

2. matrices R, U

$$R = \left[\begin{array}{cc} (I + A)(I - A)^{-1} & \sqrt{2\alpha}(I - A)^{-1}B_1 \\ \sqrt{2}C_1(I - A)^{-1} & E_{11} + C_1(I - A)^{-1}B_1 \end{array} \right]$$

$$U = \left[\begin{array}{c} \sqrt{2}(I - A)^{-1}B_2 \\ E_{12} + C_1(I - A)^{-1}B_2 \end{array} \right]$$

3. matrix U_\perp such that $[U \ U_\perp]$ is orthogonal

Then, there exists a stabilizing controller matrix K and a constant $D \in \mathcal{D}$ such that

$$\|D^{\frac{1}{2}} F_l(P_{fi}, K) D^{-\frac{1}{2}}\|_\infty < \alpha$$

if and only if the following convex set is nonempty.

$$\{Z \in \mathcal{Z} : \lambda_{\max} [U_\perp^T (RZR^* - \alpha^2 Z) U_\perp] < 0\} \neq \{\emptyset\}$$

The optimal controller gains may be computed by scaling the continuous-time plant with the constant \mathcal{D} matrices and utilizing standard \mathcal{H}_∞ state-space algorithms given in Reference [9].

This synthesis algorithm assumes complex uncertainty for the system. These results are extended to directly account for real parametric uncertainty in the control process [3]. Accounting for real uncertainty may significantly increase the number of free parameters and consequently the required computation time for synthesis. The next section considers the cost of synthesizing optimal controllers with respect to complex uncertainty. The same arguments apply to the cost of synthesizing optimal controllers with respect to real uncertainty.

Implementation of LMI Synthesis

The previous section demonstrated optimal synthesis for full information feedback reduces to a single linear matrix inequality. LMI's may be solved using standard convex optimization methods. This section investigates implementation issues and computational cost associated with solving the optimal full information synthesis problem. The convergence characteristics of algorithms are not discussed but rather the cost at each iteration of the minimization is discussed.

There are many convex optimization algorithms that may be used to solve linear matrix inequalities. The Ellipsoid Method and the Method of Centers have received a great deal of attention in recent control literature. The Method of Centers is an interior point algorithm that has been shown to be very efficient for a variety of systems and control problems [1, 7, 8, 13, 18]. Computational experiments indicate this method suffers from the type of constraints introduced in the full information synthesis formulation. This paper will concentrate on the Ellipsoid Method.

The Ellipsoid Method utilizes a subgradient vector to compute an optimizing direction for the function to be minimized. The subgradient is defined as follows [25].

Definition 0.4 *The function $f : C^n \rightarrow C$ has the set of subgradients, S , at x .*

$$S = \{g : f(y) \geq f(x) + \langle g, y - x \rangle \forall y\}$$

The subgradient vector obeys rules similar to the gradient vector and is equivalent to the gradient at differentiable points of the function. The use of the subgradient allows the Ellipsoid algorithm to be applied to minimization problems involving nondifferentiable functions.

The Ellipsoid algorithm is most easily visualized in a geometric framework [5, 6, 7]. This algorithm operates on an n -dimensional space to minimize a function with n free parameters. An ellipsoid is defined in the n -dimensional space within which the optimal solution is assumed to

lie. Each iteration of the algorithm computes a new ellipsoid of decreasing volume. The center point of each ellipsoid is tested each iteration for optimality. A subgradient condition at the center point is used to eliminate a portion of the current ellipsoid that cannot contain the optimal point. A new ellipsoid is then computed such that its volume is the smallest possible while still containing the region of the old ellipsoid that may contain the minimizing point. The optimal solution, when found, is the center of the last computed ellipsoid.

The initial ellipsoid for the algorithm must, of course, be chosen such that it contains the optimal point. There is no known method to guarantee choosing an ellipsoid that contains this point. It has been shown in practice that selecting the initial ellipsoid to be a large ball centered at the origin is often a good choice.

Many factors, including numerical conditioning of the matrices and choice of initial ellipsoid, greatly affect the convergence properties of the Ellipsoid Method. It is difficult to formulate an upper bound that is not overly conservative on the number of iterations required. Problems of similar dimension have been shown in practice to require as few as several thousand or as many as several hundred thousand iterations for convergence. The computational cost of each iteration is more tractable for analysis.

Theorem 0.3 presented the LMI formulation for synthesis. This LMI involves minimizing the maximum singular value of a matrix function by searching over a set of allowable scaling matrices. Consider the set, \mathcal{Z} , of scaling matrices for a system with n_s states and associated uncertainty scaling matrices \mathcal{D} with dimension n_u .

$$\mathcal{Z} = \left\{ \begin{bmatrix} X & \emptyset \\ 0 & D \end{bmatrix} : \begin{array}{l} X \in \mathbb{R}^{n_s \times n_s}, X = X^T > 0 \\ D \in \mathcal{D} \in \mathbb{R}^{n_u \times n_u} \end{array} \right\}$$

Every $Z \in \mathcal{Z}$ is a block diagonal matrix whose blocks must be symmetric and positive definite. Symmetry is assured in the computation algorithm by only optimizing over the unique entries of each block. Restricting each block to be positive definite arises as a set of constraints of the LMI.

The actual optimization problem to be solved is presented below explicitly stating the constraints. Consider a system with n_s uncertainty blocks and associated n_u blocks in the \mathcal{D} scaling matrices. Define D_1, D_2, \dots, D_{n_u} as the blocks in the scaling matrices.

$$\begin{aligned} & \min_{Z \in \mathcal{Z}} \bar{\lambda}(U_{\perp}^* (RZR^* - \alpha^2 Z) U_{\perp}) \\ & \text{subject to} \quad \begin{array}{l} Z_0 = X > 0 \\ Z_1 = D_1 > 0 \\ \vdots \\ Z_{n_u} = D_{n_u} > 0 \end{array} \end{aligned}$$

The total number of free parameters for this calculation can be calculated using the number of states, n_s , and the parameters for the dimensions of each type of block, C_i , c_i and R_i . Consider there are $\frac{1}{2}n(n+1)$ free parameters for a real, symmetric matrix of dimension n . The total number of free parameters is given as N .

$$N = \frac{n_s(n_s + 1)}{2} + \sum_{i=1}^m \frac{R_i(R_i + 1)}{2} + \sum_{i=1}^n \frac{C_i(C_i + 1)}{2} + p$$

The term involving the number of states, n_s , is the number of free parameters in the symmetric X scaling matrix. The first summation term computes the number of free parameters in the \mathcal{D} matrices for the real parametric uncertainty blocks. The second summation term computes the number of free parameters in the \mathcal{D} matrices for the complex parametric uncertainty blocks. The final term considers one free parameter for each scalar \mathcal{D} matrix to commute with the complex full block uncertainties.

The main cost of each iteration in the Ellipsoid Method is due to computing eigenvalues. The function to be minimized is a maximum eigenvalue that must be computed at each iteration. Additionally, the maximum eigenvalue of each constraint matrix must be computed at each iteration. The Ellipsoid Method computes a subgradient associated with the function that is the most violated, either the main function to be minimized or the constraint matrices.

The matrix dimensions can be calculated for each eigenvalue computation. Consider the dimensions of the R and U_{\perp} matrices presented in Theorem 0.3 for scalars n_s , the number of states, n_c , the number of control signals and n_u , the number of uncertainty signals.

$$R \in \mathbf{R}^{(n_s+n_u) \times (n_s+n_u)} \quad U_{\perp} \in \mathbf{R}^{(n_s+n_u) \times (n_s+n_u-n_c)}$$

The dimension of the function whose maximum eigenvalue is to be minimized can be computed.

$$U_{\perp}^* (RZR^* - \alpha^2 Z) U_{\perp} \in \mathbf{R}^{(n_s+n_u-n_c) \times (n_s+n_u-n_c)}$$

The dimension of the matrix in the first constraint function is the number of states, n_s , and the dimension of the matrix in the remaining constraint functions is simply the dimension of each block in the scaling matrix, C_i , c_i or R_i .

Computing the maximum eigenvalue for the minimization function is generally going to be the largest computational cost at each iteration. It is easy to see this dimension can become quite large for plant with a large number of states and many uncertainties. The polynomial or exponential nature of most algorithms indicates the computational cost for this eigenvalue problem makes this optimal synthesis impractical for high order systems on standard workstations.

The eigenvector associated with the maximum eigenvalue must also be computed. A subgradient may be formulated utilizing this vector. The following lemma demonstrates the subgradient calculation for the function to be minimized.

Lemma 0.5 Define the function $f(X) = \bar{\lambda}(A^*XA)$ for a given matrix $A \in \mathbf{C}^{n \times n}$ and matrix X in the set of Hermitian matrices $\mathcal{X} = \{X : X = X^* \in \mathbf{C}^{n \times n}\}$. Denote $v \in \mathbf{C}^n$ as an eigenvector corresponding to the maximum eigenvalue of $f(X)$. The following g is a suitable subgradient for $f(X)$ for some unit vector $\eta \in \mathbf{C}^n$.

$$g = Av\eta\eta^*v^*A^*$$

Proof Use standard linear algebra properties to show the following for $X, \bar{X} \in \mathcal{X}$ and the inner product defined as $\langle A, B \rangle = \text{Tr}(B^*A)$.

$$\begin{aligned} \bar{\lambda}(A^*(X + \bar{X})A) &= \max_{u^*u=1} u^*(A^*XA)u + u^*(A^*\bar{X}A)u \\ &\geq u^*(A^*XA)u + u^*(A^*\bar{X}A)u \\ &\geq \eta^*v^*(A^*XA)v\eta + \eta^*v^*(A^*\bar{X}A)v\eta \\ &\geq \bar{\lambda}(A^*XA) + (\eta^*v^*)(A^*\bar{X}A)(v\eta) \\ &\geq \bar{\lambda}(A^*XA) + \text{Tr}(\bar{X}(Av\eta\eta^*v^*A^*)) \\ &\geq \bar{\lambda}(A^*XA) + \langle g, \bar{X} \rangle \end{aligned}$$

Define $y = X + \bar{X}$ and $x = X$ to show

$$\bar{\lambda}(y) \geq \bar{\lambda}(x) + \langle g, y - x \rangle$$

which satisfies the definition of a subgradient. \square

Most of the common operations performed in the algorithm are standard matrix-vector and matrix-matrix computations. Several software packages and libraries implement these as Level 2 and Level 3 BLAS subroutines. These routines may be highly optimized for a particular architecture. The efficiency of Level 2 and Level 3 BLAS routines can often be enhanced by implementing vectorized code. Unlike most workstations, Cray supercomputers are designed for vectorized algorithms. The LAPACK package directly implements vectorized BLAS routines. This paper utilized the LINPACK, EISPACK and LAPACK packages for code generation.

Analysis of the matrices utilized in the synthesis algorithms demonstrates there is no apparent structure or sparsity that may be exploited. Previous LMI optimizations have been performed with thousands of free parameters on a standard workstation by exploiting significant structure in the computations. This algorithm will not demonstrate those qualities for a general engineering problem. The problem dimensions can become large enough that this algorithm is impractical for a standard workstation. This paper utilizes a Cray supercomputer for solving a large order synthesis problem.

Flexible Structure : Model

Controllers are designed for vibration attenuation of an experimental flexible structure. The flexible structure in this example is constructed at the *Dynamics and Controls Laboratory* in the Department of Aerospace Engineering and Mechanics at the University of Minnesota. The structure is designed to place 12 lightly damped modes between 0 and 100 rad/sec. The flexible structure is given in Figure 1.

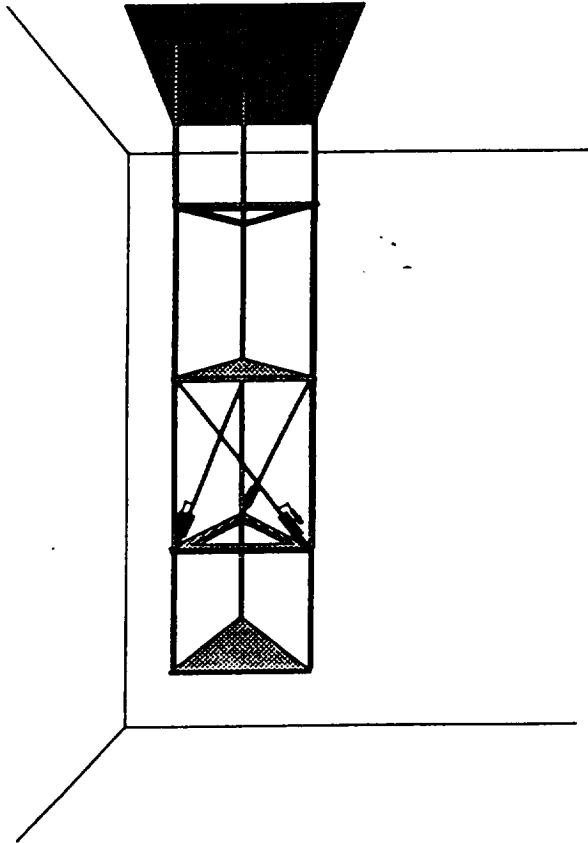

Figure 1: University of Minnesota Flexible Structure

The structure consists of a rigidly held fixed top plate and four hanging bays. Each bay contains an aluminum plate. The top four plates are spaced .62 m apart while the bottom plate is .47 m below the third bay. Plates in Bay 2 and Bay 4 are triangular frames while the other plates are solid. Each bay is connected by thin hollow rods at the corners of the plates. All components of the structure are aluminum.

Bay 3 contains sensors and actuators for control. Diagonal rods connect the top and bottom plates of this bay. Colocated linear force actuators and displacement sensors are placed along the diagonal rods. The force actuators are voice-coil type actuators produced by Northern Magnetics with a limit of ± 2 pounds of force. The displacement sensors are Trans-Tek 0242 sensors with a

linear working range of $\pm .5$ inch. Control elements of Bay 3 are given in Figure 2

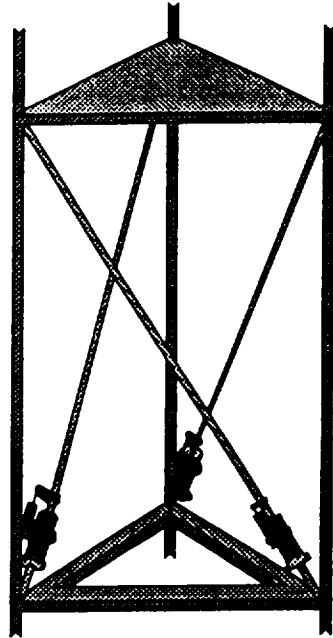

Figure 2: University of Minnesota Flexible Structure - Bay 3

Experimental transfer functions are formulated from the actuators to the displacements by commanding sinusoids of varying frequency to the actuators. System identification using curve fitting techniques and model reduction via balanced reduction computes a 22th order model [17]. Transfer functions for the model from actuators to the displacement sensors are given in Figures 3,4 and 5.

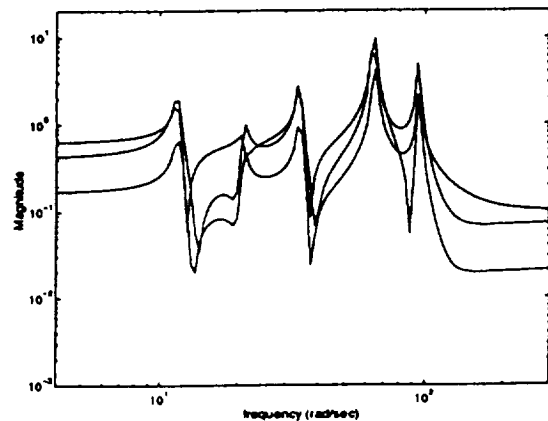

Figure 3: Transfer Function from Actuators to Displacement Sensor 1 for 22th Order Model

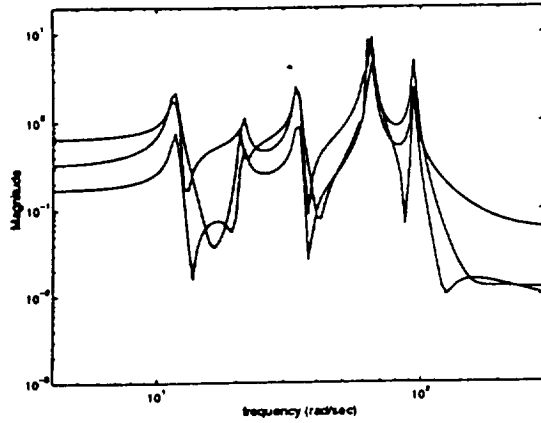

Figure 4: Transfer Function from Actuators to Displacement Sensor 2 for 22th Order Model

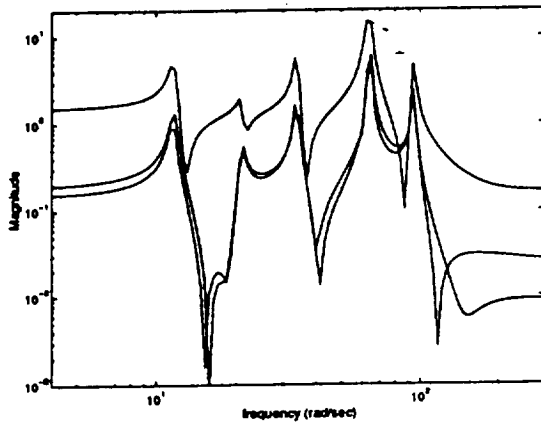

Figure 5: Transfer Function from Actuators to Displacement Sensor 3 for 22th Order Model

Flexible Structure : Control Objectives

It is desired to formulate controllers to attenuate vibrations and lower the peak gains of the open-loop system. The peak gains should be reduced approximately by a factor of 5 for modes less than 70 rad/sec. Performance weightings are included on the displacement measurements to account for the desired levels.

$$W_{perf}^1 = \frac{1}{1.2} \quad W_{perf}^2 = \frac{1}{1.2} \quad W_{perf}^3 = \frac{1}{2.0}$$

Input multiplicative uncertainty is included to account for unmodeled dynamics and neglected high frequency modes. A dynamic weighting, W_{mult} , is included on each actuator input channel.

$$W_{mult} = 10 \frac{(s+1)}{(s+1000)}$$

This weighting function puts 1.0% uncertainty at low frequency and 100% uncertainty at 100 rad/sec with 1000% uncertainty at high frequencies above 1000 rad/sec.

Parametric uncertainty is included in the plant model to account for inaccuracies in the modal damping coefficients provided by the system identification algorithm [4]. Consider the state space representation of a second order system.

$$\frac{1}{s^2 + s2\omega\zeta + \omega^2} = \left[\begin{array}{cc|c} 0 & 1 & 0 \\ -\omega^2 & -2\omega\zeta & 1 \\ \hline 1 & 0 & 0 \end{array} \right]$$

An additional input signal and output signal is included in the plant model to account for uncertainty in the damping coefficient ζ . A weighting W is included to scale the magnitude of the uncertainty parameter δ_ζ which is norm bounded by 1 in the μ framework.

$$\frac{1}{s^2 + s2\omega\zeta(1 + W\delta_\zeta) + \omega^2} = \left[\begin{array}{cc|cc} 0 & 1 & 0 & 0 \\ -\omega^2 & -2\omega\zeta & 1 & 1 \\ \hline 0 & -2\omega\zeta W & 0 & 0 \\ 1 & 0 & 0 & 0 \end{array} \right]$$

Damping uncertainty is only included on the modes near 60 rad/sec in the range of the performance weighing. These 4 modes have 50% uncertainty in the damping coefficient while the remaining low and high frequency modes have no damping uncertainty. The frequencies of the 11 modes and the range of damping coefficients are given in Table 1

frequency (rad/sec)	$\zeta_{nominal}$	ζ_{max}	ζ_{min}
11.6	.0293		
11.7	.0269		
12.1	.0021		
20.9	.0228		
33.7	.0159		
33.9	.0157		
61.4	.0084	.0126	.0042
63.4	.0142	.0213	.0071
64.2	.0152	.0228	.0076
64.4	.0116	.0174	.0058
94.4	.0101		

Table 1: Modal Frequency and Damping Values

The control signal is affected by a disturbance input. A constant weighting of $W_{dist} = .5$ is included to normalize the disturbance signal affecting each control channel. Sensor noise is also included in the system to affect the displacement sensor measurements. Constant weightings of $W_{noise} = .5$ is included to normalize the noise affecting each sensor measurement.

The magnitude of the control signal is included as a performance error to limit the amount of control actuation. A weighting of $W_{act} = .2$ is included to normalize the control measurement for each actuator.

The open-loop plant model with uncertainty blocks and weightings is given in Figure 6.

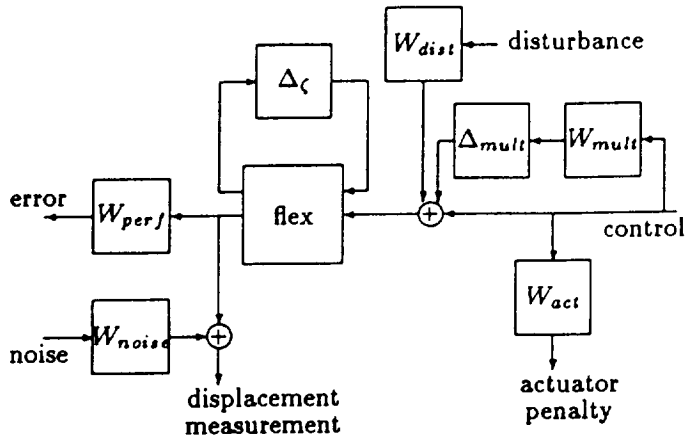

Figure 6: Open-Loop Flexible Structure Block Diagram

Flexible Structure : Control Design

The system given in Figure 6 contains two types of uncertainty. The parametric block representing uncertainty in the damping coefficients is given as Δ_{ζ} . The damping coefficients at each mode are independent of the other modes so this block is a scalar uncertainty block with four uncertainty parameters. The multiplicative uncertainty in the control signal, Δ_{mult} , is a full block uncertainty matrix with 3 inputs and 3 outputs. The uncertainty block structure is Δ .

$$\Delta = \text{diag}\{\delta_1, \delta_2, \delta_3, \delta_4, \Delta_{mult}\}$$

The modal damping coefficient uncertainty parameters, $\delta_1, \dots, \delta_4$, are real parameter variations. Varying the magnitude of δ_i between ± 1 implies the damping coefficient ζ_i for the i^{th} mode varies between the maximum and minimum values given in Table 1. They are treated in the synthesis procedure as complex variations but they are considered as real parameters in the analysis. The multiplicative input uncertainty contains magnitude and phase information and is treated as a complex linear, time-invariant uncertainty.

The uncertainty block structure is augmented with a performance block for computing robust performance. The performance block is a full block uncertainty matrix with 6 inputs (3 disturbance and 3 noise signals) and 6 outputs (3 errors and 3 actuator penalties). This block is always treated as a complex linear, time-invariant uncertainty.

An optimal full information controller is computed for this system. This controller, K_{FI} , is synthesized assuming all uncertainty parameters are complex, time-varying. A future project will provide computational

resources for synthesizing a controller that directly accounts for the additional phase information provided by the real uncertainty parameters.

An output feedback controller is also designed for this system using $D-K$ iteration. The feedback measurements to the controller are noisy signals from the displacement sensors. This controller, denoted K_{DK} , is of order 34 after a single $D-K$ iteration. K_{DK} assumes all uncertainty is complex time-invariant. The Bode plot of K_{DK} is given in Figure 7.

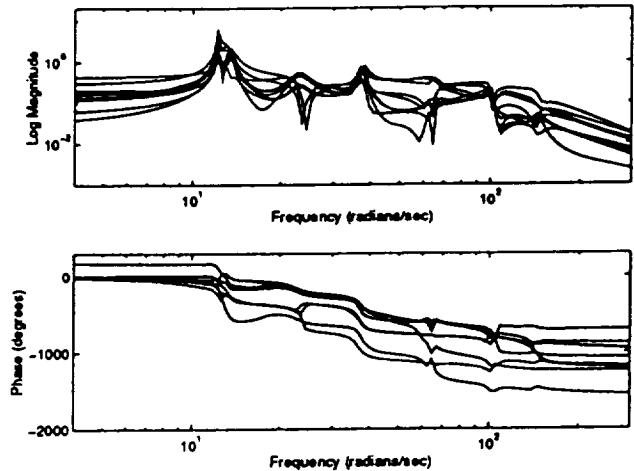

Figure 7: Bode plot of controller K_{DK}

The closed-loop transfer functions for the controllers are given in Figure 8. Each controller attenuates the response at the natural frequencies. The full information controller is an optimal controller and achieves better attenuation levels than the output feedback controller. The low frequency performance of K_{DK} is especially poor.

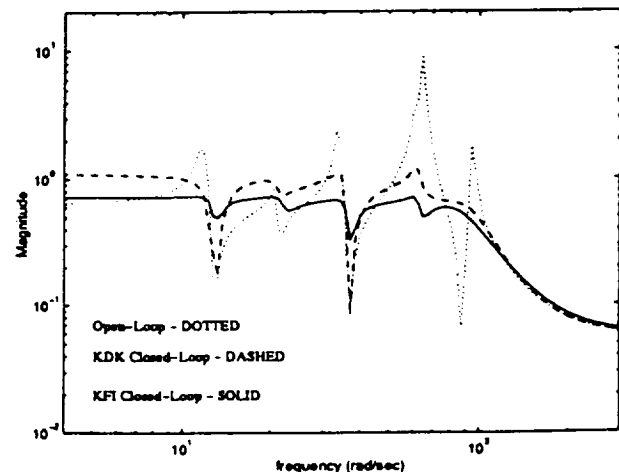

Figure 8: Closed-Loop Transfer Functions

Flexible Structure : Robustness Analysis

Robust stability with respect to time-invariant uncertainty may be analyzed for the linearized plant model for each controller using the μ -Analysis and Synthesis Toolbox [2]. The upper and lower bounds for robust stability μ with respect to real and complex uncertainty are given in Figure 9. The μ values achieved are .90 for K_{DK} and .93 for K_{FI} .

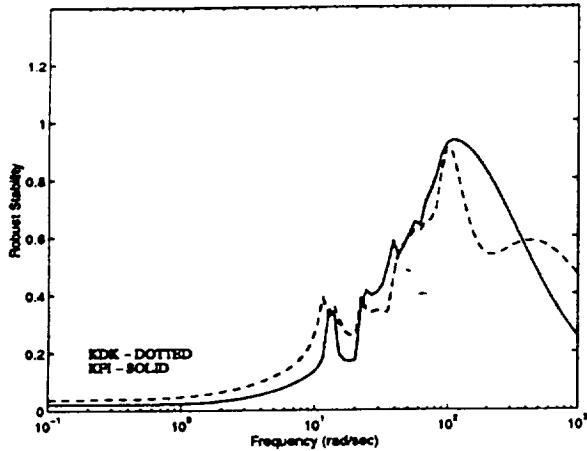

Figure 9: Real/Complex Robust Stability μ

The μ values for robust stability with respect to all complex uncertainty are similar to Figure 9. Treating the parametric damping uncertainty as complex does not decrease the robustness of either controller.

Robust stability for each controller is driven by the uncertainty at the higher modes. The peak μ values occur at frequencies of the modes which contain damping uncertainty and a significant amount of multiplicative uncertainty. Robust stability is achieved at low frequencies where the uncertainty is low and also at frequencies higher than the natural frequencies.

K_{DK} achieves a lower robust stability μ value than the optimal controller K_{FI} . This does not contradict the synthesis theory. K_{FI} is designed to minimize robust performance and does not directly consider robust stability.

Nominal performance is also computed for both controllers. The μ values achieved are 1.18 for K_{DK} and .46 for K_{FI} . The output feedback controller is unable to meet the performance specifications at low frequency while the full information controller achieves the desired performance goals over all frequencies. The nominal performance μ values agree with the poor low frequency performance shown in the closed-loop transfer function in Figure 8. The nominal performance μ values are given in Figure 10.

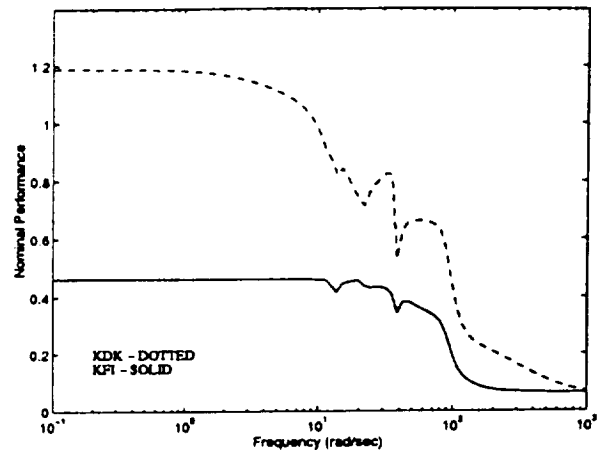

Figure 10: Nominal Performance μ

The robust performance μ for each controller is given in Figure 11 for mixed real and complex uncertainty. The robustness levels are not noticeably changed by considering the damping uncertainty as complex or real. The robust performance levels achieved are 1.23 for K_{DK} and 1.09 for K_{FI} .

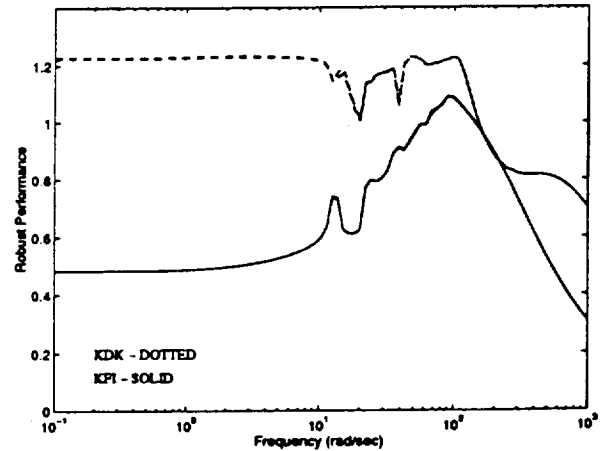

Figure 11: Real/Complex Robust Performance μ

Figure 11 shows the full information controller is able to achieve a robust performance μ value less than the output feedback controller. μ for K_{FI} is approximately 20% less than K_{DK} with complex and real uncertainty.

Neither controller is able to meet the desired robustness and performance specifications for the amount of included uncertainty. K_{FI} shows μ close to the desired levels and is only 9% from the desired goal. A reduction to $1/1.09$ or 92% of the amount of input uncertainty results in K_{FI} achieving robust performance.

Robust performance for each controller is not affected by restricting the damping uncertainty values to be purely real. The output feedback controller, K_{DK} , is driven by the additive noise which affects the achievable perfor-

mance at low frequency. The full information controller, K_{FI} , is driven by the input multiplicative uncertainty at the high frequency modes. The additional damping uncertainty increases the level of difficulty in designing a controller but restricting that uncertainty to be real does not increase robustness for the controller. It is unclear that including real uncertainty in the synthesis algorithm would lead to more robust controllers.

Time simulations of the open-loop and closed-loop systems for each controller for the linearized plant model are given in Figure 12. The full information controller achieves the desired attenuation while the output feedback controller shows slightly less attenuation.

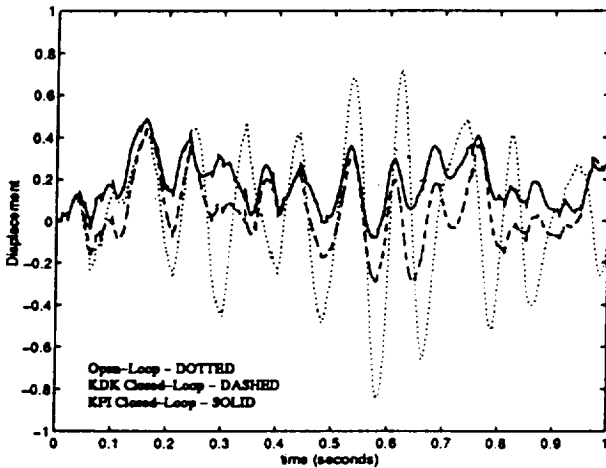

Figure 12: Time Simulations

Flexible Structure : Computational Cost

The computational cost of computing the optimal full information controller is dependent of the number of free parameters in the optimization. This number is determined by the number of states and the uncertainty structure in the set \mathcal{Z} in Theorem 0.3.

The open-loop system given in Figure 6 shows the block diagram for control synthesis. This system contains 25 states from the flexible structure and weighting matrices. The uncertainty block structure contains 4 scalar blocks to represent the parametric uncertainty and a full block for the multiplicative uncertainty. The total number of free parameters is N .

$$N = \frac{1}{2}25(25 + 1) + 4 + 1 = 330$$

Each iteration of the optimization algorithm computes several eigenvalues and eigenvectors. The largest matrix used for the eigenspace computation is the matrix function of dimension 38 given in Theorem 0.3.

$$U_1^* (RZR^* - \alpha^2 Z) U_1 \in \mathbb{R}^{38 \times 38}$$

A single processor Cray-XMP supercomputer is used to compute the optimal controller in this paper. The algorithm implements a bisection search for the lowest achievable μ upper bound. The number of iterations required for each μ level are shown below.

μ level	iterations	result
1.10	330261	controller exists
0.75	335701	no controller exists
0.92	394868	no controller exists

Standard workstations were initially utilized for controller synthesis since the eigenspace dimension is not extreme. The algorithm was terminated after *several days* without reaching an optimal controller. Each iteration with the eigenspace computation took only 1 second approximately but this implies 11 days are required to compute the million iterations needed for the controller synthesis.

The Cray supercomputer is able to directly utilize vectorized loops in the eigenspace computation to significantly reduce the execution time for each iteration of the optimization. The execution time to compute the optimal controller was approximately 6 hours.

Conclusion

This paper considers a computational algorithm for optimal controller synthesis. The formulation of a globally optimal controller for full information feedback is shown to reduce to an LMI optimization. Implementation of this optimization using the Ellipsoid Method requires many expensive eigenvalue and eigenvector computations. A flexible structure is presented as an example to synthesize controllers for vibration attenuation. The resulting problem formulation is of large enough dimension with no apparent sparsity or structure that a standard workstation requires several days for the computation. A vectorizing Cray supercomputer is used for synthesis.

Acknowledgements

The authors wish to acknowledge the generous financial support from NSF (ECS-9110254), NASA Langley (NAG-1-821), Johns Hopkins University Applied Physics Laboratory (BPO-2229), Naval Weapons Center (N60530-91-C-0218) and the University of Minnesota McKnight Land Grant Professorship. Volkan Nalbantoglu and Peter Thomson provided the flexible structure model. Supercomputer resources were provided by the Minnesota Supercomputer Institute and Cray Research.

References

- [1] V. Balakrishnan, E. Feron, S. Boyd and L. El Ghaoui, "Computing Bounds for the Structured-Singular Value via an Interior Point Algorithm," *Proceedings of 1992 American Control Conference*, Chicago IL, June 1992, pp. 2195-2196.
- [2] G. Balas, J. Doyle, K. Glover, A. Packard, and R. Smith, *μ -Analysis and Synthesis Toolbox : Users Guide*, MUSYN and The Mathworks, Natick, MA, Dec. 1990.
- [3] G. Balas, R. Lind and A. Packard, "Optimally Scaled \mathcal{H}_∞ Full Information Control Synthesis with Real Uncertainty : Theory and Applications," accepted for publication in *AIAA Journal of Guidance, Control, and Dynamics*, April 1995.
- [4] G. Balas and P. Young, "Control Design for Variations in Structural Natural Frequencies," *AIAA Journal of Guidance, Control and Dynamics*, Vol. 18, No.2, March 1995, pp. 325-332.
- [5] R. Bland, D. Goldfarb, and M. Todd, "The Ellipsoid Method : A Survey," *Operations Research*, vol. 18, no. 6, Nov-Dec 1980, pp. 1039-1091.
- [6] S. Boyd and C. Barratt, *Linear Controller Design : Limits of Performance*, Prentice Hall, New Jersey, 1991.
- [7] S. Boyd, L. El Ghaoui, E. Feron, V. Balakrishnan, *Linear Matrix Inequalities in System and Control Theory*, SIAM Studies in Applied Mathematics, SIAM, Philadelphia, 1994.
- [8] S. Boyd and L. El Ghaoui, "Method of Centers for Minimizing Generalized Eigenvalues," *Linear Algebra and Applications, special issue on Numerical Linear Algebra Methods in Control*, July 1993, pp. 63-112.
- [9] J.C. Doyle, K. Glover, P.P. Khargonekar, and B.A. Francis, "State-Space Solutions to Standard \mathcal{H}_2 and \mathcal{H}_∞ Control Problems," *IEEE Transactions on Automatic Control*, vol. 34, no. 8, August 1989, pp. 831-847.
- [10] M. K. Fan, A. L. Tits, and J. Doyle, "Robustness in the Presence of Mixed Parametric Uncertainty and Unmodeled Dynamics," *IEEE Transactions on Automatic Control*, Vol. 36, January 1991, pp. 25-38.
- [11] K. Glover and J.C. Doyle, "State-Space Formulae for all Stabilizing Controllers that Satisfy an H_∞ -norm Bound and Relations to Risk Sensitivity," *Systems & Control Letters*, vol. 11, 1989, pp. 167-172.
- [12] J. How, R. Glaese, S. Grocott and D. Miller, "Finite Element Model Based Robust Controllers for the MIT Middeck Active Control Experiment (MACE)," *Proceedings of the 1994 American Control Conference*, Baltimore, MD, June 1994, pp. 272-277.
- [13] F. Jarre, "An Interior-Point Method for Minimizing the Maximum Eigenvalue of a Linear Combination of Matrices," *Linear Algebra for Large Scale and Real-Time Applications*, M. Moonen et al editors, Kluwer Academic Publishers, The Netherlands, 1993, pp. 395-396.
- [14] R. Lind, G. Balas and A. Packard, "Evaluating D-K Iteration for Control Design," *Proceedings of the 1994 American Control Conference*, Baltimore, MD, June 1994, pp. 2792-2797.
- [15] R. Lind, G. Balas and A. Packard, "Robustness Analysis with Linear Time-Invariant and Time-Varying Real Uncertainty," *1995 AIAA Guidance, Navigation and Control Conference*, July 1995, pp. 132-140.
- [16] J. Ly, M. Safonov and F. Ahmad, "Positive Real Parrott Theorem with Application to LMI Controller Synthesis," *Proceedings of the 1994 American Control Conference*, Baltimore, MD, June 1994, pp. 50-52.
- [17] V. Nalbantoglu, G. Balas and P. Thomson, "Performance Criteria Selection in the Control of Flexible Structures," submitted to *1996 AIAA Guidance Navigation and Control Conference*.
- [18] Y. Nesterov and A. Nemirovsky, *Interior-Point Polynomial Methods in Convex Programming*, SIAM Studies in Applied Mathematics, SIAM, Philadelphia, 1994.
- [19] A. Packard and J. Doyle, "The Complex Structured Singular Value," *Automatica*, vol. 29, no. 1, June, 1993, pp. 71-109.
- [20] A. Packard, J. Doyle, and G. Balas, "Linear, Multivariable Robust Control with a μ Perspective," *ASME Journal of Dynamics, Measurements and Control : Special Edition on Control*, vol. 115, no. 2(B), June 1993, pp. 426-438.
- [21] A. Packard, K. Zhou, P. Pandey, J. Leonhardson and G. Balas, "Optimal Constant I/O Similarity Scaling for Full Information and State Feedback Control Problems," *Systems & Control Letters*, vol 19, 1992, pp. 271-280.
- [22] A. Packard, K. Zhou, P. Pandey, and G. Becker, "A Collection of Robust Control Problems Leading to LMI's," in *Proceedings of the IEEE Conf. on Decision and Control*, Brighton, England, December 1991, pp. 1245-1250.
- [23] R.T. Reichert, "Robust Autopilot Design Using μ -Synthesis," *Proceedings of the 1990 American Control Conference*, San Diego, CA, June 1990, pp. 2368-2373.
- [24] J. Shamma, "Robust Stability with Time-Varying Structured Uncertainty," *IEEE Transactions on Automatic Control*, vol. 39, no. 4, April 1994, pp. 714-724.
- [25] N. Shor, *Minimization Methods for NonDifferentiable Functions*, Springer-Verlag, Berlin, 1985.
- [26] B. Song and S. Jayasuriya, "Active Vibration Control Using Eigenvector Assignment for Mode Localization," *Proceedings of the 1993 American Control Conference*, San Fransisco, CA, June 1993, pp. 1020-1024.
- [27] P. Young, M. Newlin, and J. Doyle, " μ Analysis with Real Parametric Uncertainty," *Proceedings of the IEEE 30th Conference on Decision and Control*, Brighton, England, December 1991, pp. 1251-1256.