



1N-29-TM

067603

NASA/TM-94- 207297

AIAA 94-0334

**CRYSTAL GROWTH FURNACE SYSTEM
CONFIGURATION AND PLANNED
EXPERIMENTS ON THE SECOND UNITED
STATES MICROGRAVITY LABORATORY
MISSION**

R. Srinivas, G. Hambright, M. Ainsworth, M. Fiske,
Teledyne Brown Engineering, Huntsville, Alabama, USA

D. Schaefer, NASA Marshall Space Flight Center,
Alabama, USA

**32nd Aerospace Sciences
Meeting & Exhibit**
January 10-13, 1994 / Reno, NV

CRYSTAL GROWTH FURNACE SYSTEM CONFIGURATION AND PLANNED EXPERIMENTS ON THE SECOND UNITED STATES MICROGRAVITY LABORATORY MISSION

R. Srinivas*, G. Hambright†, M. Ainsworth‡, M. Fiske§, Teledyne Brown Engineering, Huntsville, Alabama 35807
D. Schaefer¶, NASA, Marshall Space Flight Center, Alabama 35812

Abstract

The Crystal Growth Furnace (CGF) is currently undergoing modifications and refurbishment and is manifested to re-fly on the Second United States Microgravity Laboratory (USML-2) mission scheduled for launch in September 1995. The CGF was developed for the National Aeronautics and Space Administration (NASA) under the Microgravity Science and Applications Division (MSAD) programs at NASA Headquarters. The refurbishment and re-flight program is being managed by the Marshall Space Flight Center (MSFC) in Huntsville, Alabama. Funding and program support for the CGF project is provided to MSFC by the office of Life and Microgravity Sciences and Applications at NASA Headquarters. This paper presents an overview of the CGF system configuration for the USML-2 mission, and provides a brief description of the planned on-orbit experiment operation.

Introduction

The CGF successfully completed its maiden flight in June/July 1992 on the First United States Microgravity Laboratory (USML-1) mission. The system performed successfully in all aspects, and all the mission objectives were met. Seven samples were successfully processed yielding valuable results. During the mission, a number of system capabilities were exercised, including demonstration of the crew interaction with the experiment hardware using the Flexible Glovebox (FGBX) for sample insertion and retrieval. The Principal Investigator (PI) was allowed interaction with the experiment operation by means of real-time ground commanding to control the initiation of crystal growth. The flight hardware was returned to the contractor facility in September 1992 for postflight checkout which was completed in December 1992. At the same time, postflight ground truth science testing in the Ground Control Experiment Laboratory (GCEL) unit for all the four USML-1 PIs was also performed and concluded in February 1993. Since then, the CGF system has been undergoing refurbishment and modification to upgrade the system capabilities to accommodate additional science requirements and enhance the system reliability for flight on the USML-2 mission. The key upgrades to the system are as follows: (1) The addition of the Current Pulse Interface Demarcation (CPID) capability, (2) the development of a new Sample Ampoule/Cartridge Assembly (SACA) to provide the necessary interface for current pulsing through the sample via the CPID system, and (3) modification to the Control and Data Acquisition System (CDAS) to incorporate an 80486 Control Processing Unit (CPU) and a new Remote Acquisition Unit (RAU) Interface. The refurbishment and modification of the GCEL unit has been completed and is currently supporting the ground-based science development testing for the reflight of the four USML-2 peer-selected experiments along with an additional Interface Demarcation Flight Test (IDFT). The flight unit refurbishment and modification activities are progressing well to support the launch schedule of September 1995. The hardware delivery to the Kennedy Space Center (KSC) for mission integration is scheduled for September 1994.

In this paper, a brief description of the various modifications to the CGF system is presented, and an overview of the system configuration for the USML-2 mission is given. A brief description of the planned on-orbit experiments is also presented.

CGF System Configuration

The CGF USML-1 baseline configuration is described in reference 1. Only modifications/additions to this baseline system configuration are described here briefly.

CGF System Modifications

Modifications to the CGF system for the USML-2 mission have been based upon the following:

- Lessons learned from USML-1
- PI and mission-specific requirements
- Upgrades to system

The following changes have been incorporated into the system design as a part of lessons learned from USML-1:

- RAU interface board in the CDAS has been redesigned, and the flight software has been modified to prevent "skip" condition and Dedicated Experiment Processor (DEP) load problems.
- Onboard crew displays on the Spacelab Data Display System (DDS) have been streamlined and are being updated to provide additional system data and to include command protection for certain critical, crew-initiated commands.
- Onboard-generated error messages have been updated.
- Changes resulting from PI and mission-specific science requirements include the following:
 - Addition of the CPID capability to send current pulses into the sample being processed to mark and locate the crystal growth interface (by means of Peltier effect)
 - Development of the SACA to provide interface for CPID
 - Upgrades to science data and graphics displays for PI use on the ground
- Upgrades to the system consists of the following:
 - CPID system
 - CPID SACA
 - Modifications and upgrades to the Integrated Furnace Experiment Assembly (IFEA)

- Modified Ampoule Support Plate Drive Assembly and Trunion Assembly to prevent overtravel
- Redesigned upper support plate to allow easier disassembly
- CPID Mate/Demate Wiper Assembly to allow easy installation of CPID SACAs
- Relocation of thermocouple reference junction to allow more flexibility in SACA location within the Sample Exchange Mechanism (SEM) and to accommodate late changes to sample thermocouple selection
- Addition of lights inside the IFEA to enhance visibility of the SACAs through the viewport

* Program Scientist, Senior Member AIAA

† Program Manager; ‡ Lead Systems Engineer; § Lead Engineer SACA Development, Member AIAA

¶ Project Manager

- CDAS upgrade to incorporate 80486 CPU and redesigned RAU/communications interface
- Replacement of power module feedthrough capacitors to increase electrical stress margin
- Replacement of the Remote Controlled Circuit Breakers (RCCBs) in the Power Distribution System (PDS) with newly designed and fabricated units.
- Upgrades to the flight software to accommodate new requirements and provide additional capabilities and flexibility
- Modification to the Mechanical Ground Support Equipment (MGSE)

- New Environmental Control System (ECS) panel to enable better verification of interfaces and control functions

A summary of the modifications/enhancements to the CGF system is given in Table I. In addition, a new flight RFM has been built to the same configuration as flown on the USML-1 mission. The USML-1 flight RFM has been installed in the GCEL IFEA and is currently supporting the ground-based science development testing. A detailed description of the CPID system and the CPID SACA is given below.

Table I. Summary of Modifications/Enhancements to the CGF System.

MODIFICATION/ENHANCEMENT	BASIS/OBJECTIVE
CPID SYSTEM	PROVIDES CONTROLLED CURRENT PULSE TO INTRODUCE INTERFACE DEMARICATION IN SAMPLE <ul style="list-style-type: none"> - CDAS UPGRADE TO 80846 CPU - PELTIER CURRENT DRIVE - MODIFIED ARCHITECTURE TO INCREASE REDUNDANCY IN PCS
CPID SACA	PROVIDES CONTAINMENT FOR GaAs:Se AND Ge:Ga SAMPLES AND SUPPORTS CURRENT DELIVERY TO SAMPLE
IFEA MODS <ul style="list-style-type: none"> • RFM TRUNNION ASSY • AMPOULE SUPPORT PLATE DRIVE ASSY • UPPER SUPPORT PLATE • CPID MATE/DEMATE • T/C REFERENCE JUNCTION RELOCATION • LIGHTING 	<ul style="list-style-type: none"> - DESIGN UPGRADE - DESIGN UPGRADE - REDESIGNED TO ALLOW EASIER DISASSEMBLY - DESIGNED TO ALLOW EASY INSTALLATION OF CPID SACAs - ALLOWS MORE FLEXIBILITY IN SAMPLE LOCATION, LATE CHANGES TO T/C SELECTION - TO ENHANCE VISIBILITY INSIDE THE IFEA THROUGH THE VIEWPORT
RAU COMMUNICATIONS INTERFACE	HW & SW REDESIGN TO IMPROVE COMMUNICATIONS INTERFACE
POWER MODULE FEEDTHROUGH CAPACITORS	REPLACE COMPONENTS TO INCREASE ELECTRICAL STRESS MARGIN
RCCB	REPLACE EXISTING RCCBs IN THE PDS WITH NEWLY DESIGNED AND FABRICATED RCCBs
RACK 7 HARDWARE FABRICATION	HARDWARE FOR VIBRATION TESTING OF AVIONICS COMPONENTS
MGSE MODIFICATIONS <ul style="list-style-type: none"> • AIR SERVICER BLOWER • FLOW MEASUREMENT ON WATER SERVICER • ECS PANEL REPLACEMENT 	<ul style="list-style-type: none"> - PROPER FLOW BALANCING IN AVIONICS BOXES DURING GROUND TESTING - PROVIDE INFORMATION ON PRESSURE DROP VS FLOW RATE FOR VERIFICATION - BETTER VERIFICATION OF CGF CONTROL FUNCTIONS AND INTERFACES
RFM	NEW UNIT FABRICATED
GRADIENT ZONE	FABRICATION OF OPTIONAL GRADIENT ZONES TO ACCOMMODATE SCIENCE REQUIREMENTS
FLIGHT SOFTWARE	UPGRADE TO ACCOMMODATE NEW REQUIREMENTS AND PROVIDE ADDITIONAL CAPABILITIES AND FLEXIBILITY

Sample Interface Demarcation System (SIDS) Design

The Sample Interface Demarcation System (SIDS) provides the capability to mark the shape and location of the crystal growth interface in the experiment sample during processing operations. The SIDS capabilities are divided into two main functions, Mechanical Pulse Interface Demarcation (MPID) and Electrical Pulse Interface Demarcation (EPID). The mechanical portion of the SIDS capabilities is available for all SACAs which meet certain interface definition criteria, while the CPID functions are available only for those experiment samples contained in a CPID SACA.

All SIDS functions operate under the control of the CDAS software. The software controls the SIDS functions in accordance with a user-defined timeline, where system parameters such as the amplitude, width, timing, and polarity of each pulse may be specified. The software monitors SIDS system performance to prevent damage to the hardware and to reconfigure the system in an effort to continue operations in the event of a failure.

The major SIDS requirements are defined as follows:

- Mechanical pulsing: Mechanically impact the SACA with a variable intensity acceleration of up to 1 g.

- Electrical pulsing (CPID): Force a pulse of current to flow through the CPID SACA.
 - Pulse amplitude: 10 to 57 A; the maximum current available is dependent upon the electrical resistance of the CPID connections inside the SACA (see Figure 1); the amplitude is user selectable in 1-A increments, and is accurate to $\pm 3\%$ of the pulse amplitude setting.
 - Pulse width: 25 to 100 msec; the width is user selectable in 1-msec increments and is accurate to $\pm 5\%$ of the pulse width setting.
 - Pulse period (time between pulses): ≥ 1 sec; the period is user selectable in 10-msec increments.
 - Pulse polarity: User selectable.
 - Pulse transition (rise, fall) time: ≤ 5 msec.
 - Data available to user (CPID only): Peak current and voltage measurements; accurate to $\pm 1.5\%$ of full scale; monitored once per pulse.

A functional block diagram of the CGF SIDS is shown in Figure 2. The two SIDS functions (MPID and EPID) CGF system to minimize the overhead associated with each.

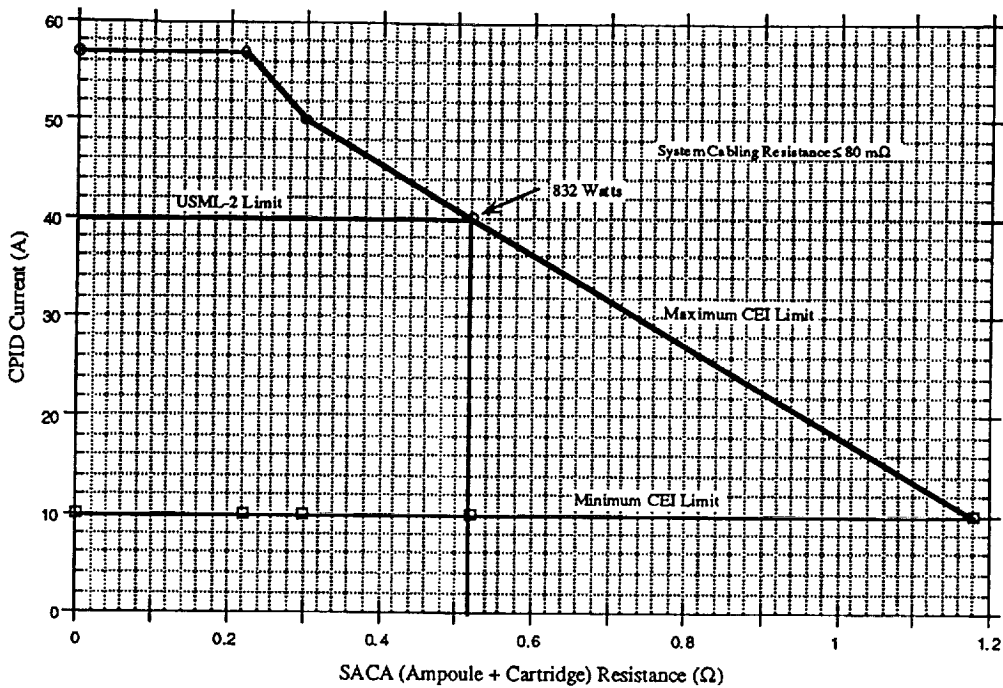

Fig. 1. CPID Current versus SACA Resistance.

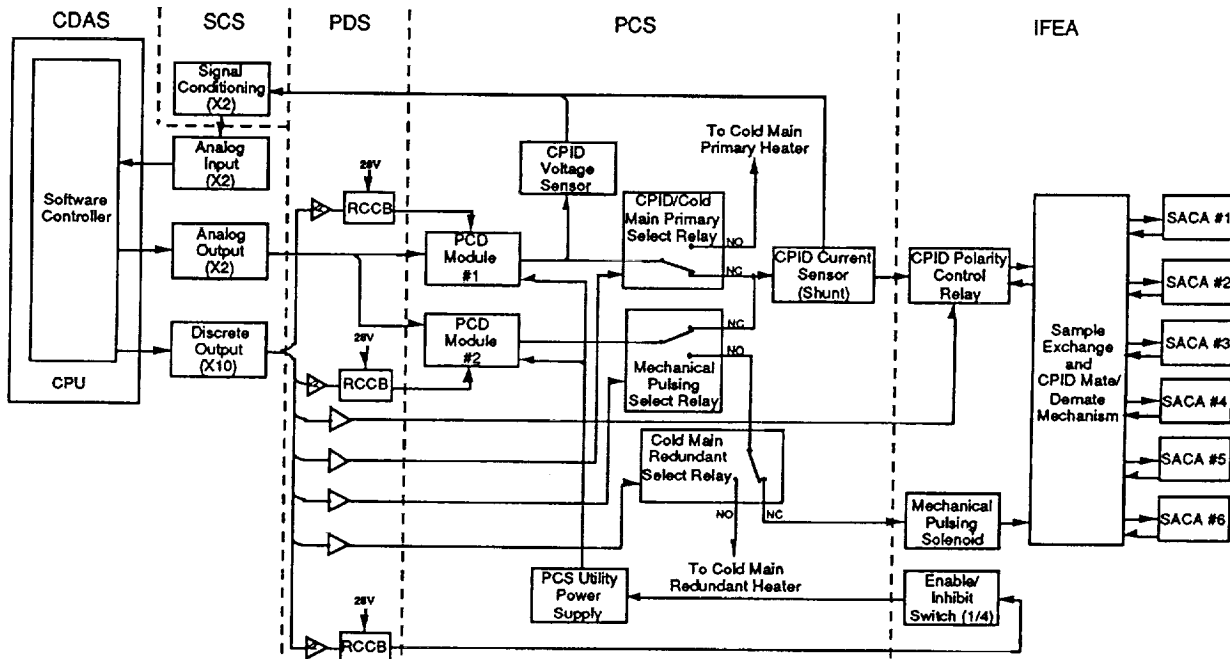

Fig. 2. CGF Sample Interface Demarcation System Block Diagram.

As indicated in Figure 2, the SIDS Software Controller resides within the CDAS computer on the CPU board. After retrieving the appropriate SIDS timeline data base, the software commands an analog output voltage from the CDAS which represents the desired current pulse waveform and timing. This waveform provides the control input to the two Peltier Current Drive (PCD) modules located in the Power Conditioning System (PCS). These amplifiers provide an output current which is proportional to the input control voltage. Depending upon the configuration of the three relays in the PCS, this current is routed either to the mechanical

pulsing solenoid or to the CPID mate/demate mechanism (both located within the IFEA), where (for CPID operations) it is transmitted across the SEM and into the SACA. This mechanism performs a multiplexing function, such that only the SACA which is located in the processing position receives the electrical or mechanical pulse. A relay in the IFEA, operated under SIDS software control, enables the system to reverse the polarity of the CPID current flowing into the SACA. A switch located in the IFEA allows the crewmember to inhibit SIDS operations during the manual sample exchange process to eliminate the possibility of electrical shock.

Several features have been designed into the CGF SIDS to improve the system operations and to provide additional support of the science requirements. These are as follows:

- Real-time commands will be available to enable the user to modify the existing or any future timeline segments, to hold and restart the timeline at any point, and to transmit a "pulse now" command.
- The PCDs are current sources, where the output current is the controlled parameter. This results in superior current amplitude control performance over a wide range of SACA resistances when compared to the use of traditional voltage sources.
- The PCDs enable the delivery of high peak currents into a wide range of SACA resistances. Each PCD is capable of providing a peak output power of up to 500 W, with a peak compliance voltage exceeding 26 V at full load.
- The SIDS protects itself from damage due to electrical faults. The PCDs will recover from operation into either an open- or a short-circuit without damage. In addition, the software controller monitors the power provided by the PCDs. If this power exceeds the rated value, the current pulse is terminated.
- In the event of a CGF hardware failure, the CGF software may reconfigure the PCS relays to enable the SIDS PCDs to be used in support of furnace temperature control. SIDS capabilities will be reduced accordingly in this event.

CPID SACA Design

The development of a SACA to support the processing of gallium arsenide (GaAs:Se) and gallium-doped germanium (Ge:Ga) using CPID has posed a significant design challenge. Chemical compatibility among a cartridge material, the sample material (in the event of an ampoule failure), other internal SACA components, and the furnace environment is a serious issue that requires a detailed understanding of the high temperature reactions involved. The first problem is that a single cartridge material may not be suitable for all applications, unless a properly designed coating can be developed. In addition, thermocouples and CPID conductors must survive in the internal SACA environment. Choices with respect to sheathed versus unsheathed thermocouples, ampoule failure detection sensors, ampoule feedthrough design for CPID samples, and insulation pre-treatment must all be addressed to ensure a proper thermochemical balance within the confines of a SACA at elevated temperatures. This balance is driven by potential platinum/alumina gas rings that are driven by low oxygen partial pressures in the gas environment between platinum and alumina components, outgassing of various components within the SACA, and diffusion of thermocouple elemental material, causing thermocouple decalibration. These requirements become even more significant when coupled with the geometric constraints imposed by the CGF system and PIs, including a maximum cartridge diameter of 1.009 inches on a 24-inch-long tube closed on one end and with a 0.030-inch wall thickness.

Over the past 3 years, the CGF team has expended significant effort to develop SACAs for the USML-1 and for the upcoming USML-2 flight of the CGF. Various cartridge materials have been evaluated including alumina, pyrolytic boron nitride, graphite, molybdenum, TZM, various carbides, and rhenium, in addition to the two materials that flew on USML-1: WC-103 (Nb/Hf/Ti alloy) with silicide coating and Inconel. For the USML-2 flight of the CGF, the new design efforts are mainly directed towards the production of flight SACAs for the GaAs:Se sample, and the IDFT (Ge:Ga) both of which utilize the CPID capability. This effort has led to the requirement for the development of new cartridge material/ fabrication methods and/or a coating on the

interior of the cartridge. The coating must not only contain liquid sample materials and possible decomposition products, but it must be able to be applied uniformly down the length of the tube with a large aspect ratio. In addition, it must be compatible with the cartridge material and all internal SACA components.

Materials compatibility testing on various cartridge materials/coatings and possible chemical reactions with Ga, As, or GaAs have been performed.

The CPID SACA design is essentially similar to the SACA design flown on USML-1, with the exception of provisions made to incorporate components required to support electrical pulsing through the sample material. These components include both input and output electrical conductors, means to attach these conductors to the ampoule, and an additional connector devoted to CPID power delivery. A typical CPID SACA design configuration is depicted in Figure 3.

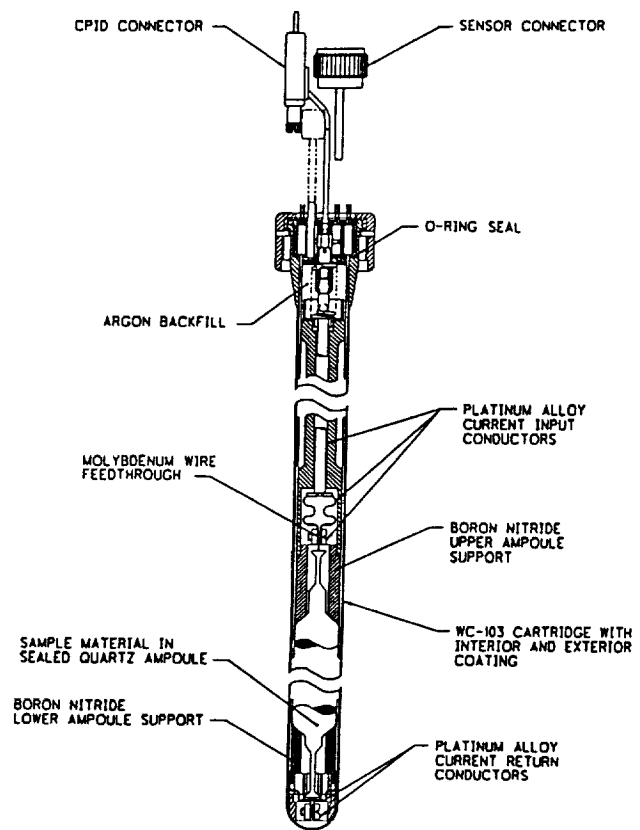

Fig. 3. Typical CPID SACA Design Configuration.

The PI-provided CPID ampoule is delivered with molybdenum feedthroughs attached on each end. These feedthroughs terminate in wire loops which are attached to platinum lugs using a platinum screw/nut/washer combination on each end. At the top of the ampoule, six platinum wires are welded to the lugs and also welded to a platinum input electrode which is located in the center of the SACA and terminates at the top of the SACA in a lead wire. The six wires allow for differential thermal expansion of internal SACA components during thermal cycling. At the bottom of

the ampoule, the same configuration is used, but the six return conductors are enclosed in single-hole alumina insulators, located circumferentially around the ampoule, and routed back up to the top of the SACA where they are welded to a common bus which also terminates in a lead wire. Six bare wire S-type thermocouples are provided for active temperature monitoring of sample temperatures. These thermocouples are housed in double-hole alumina insulators which are also located circumferentially around the ampoule but spaced between the return conductor insulators. Lastly, a two-pin connector has been added to the CPID SACA to transfer electrical pulses from the CGF SEM to the SACA.

CGF USML-2 Configuration

The CGF system configuration layout and the Spacelab-CGF interfaces for the USML-2 mission are shown in Figures 4 through 6.

The IFEA is mounted in a special CGF support structure provided as Mission-Peculiar Equipment (MPE). The special support structure replaces a standard Spacelab double rack (rack 9) and interfaces with the Spacelab module using the same hard point locations as the double rack. The interface of the IFEA to the special support structure is by means of an interface adapter plate to which the IFEA base ring attaches. To provide a better operational envelope, the IFEA is canted forward by 12 degrees. All resource interfaces are at the base of the IFEA. Argon is provided as a standard resource from a special onboard MPE storage tank. A bleed accumulator in the water cooling loop is also provided as MPE. Both the argon tank and the accumulator are mounted under the module floor directly beneath the IFEA. Some of the ECS components are mounted underfloor and some on the support structure.

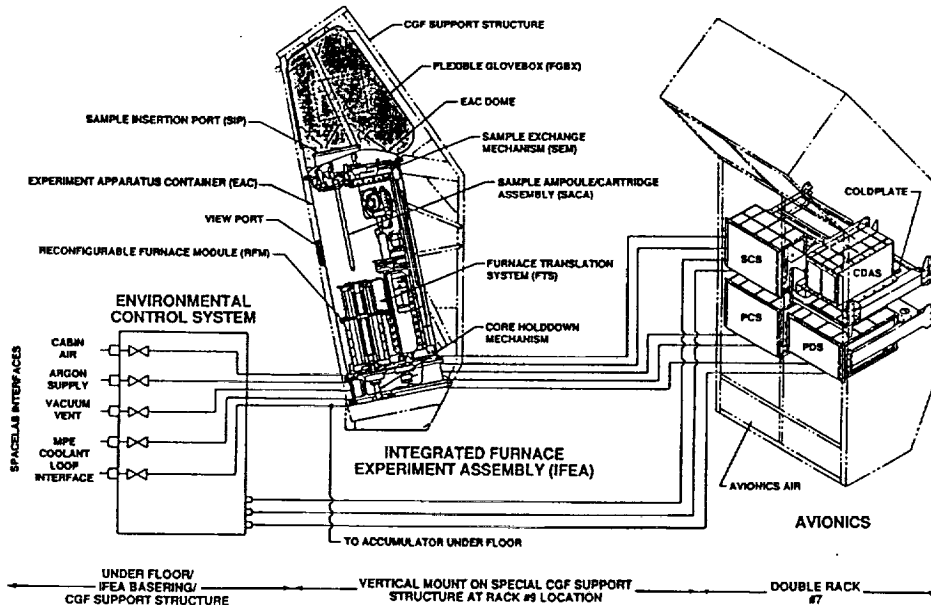
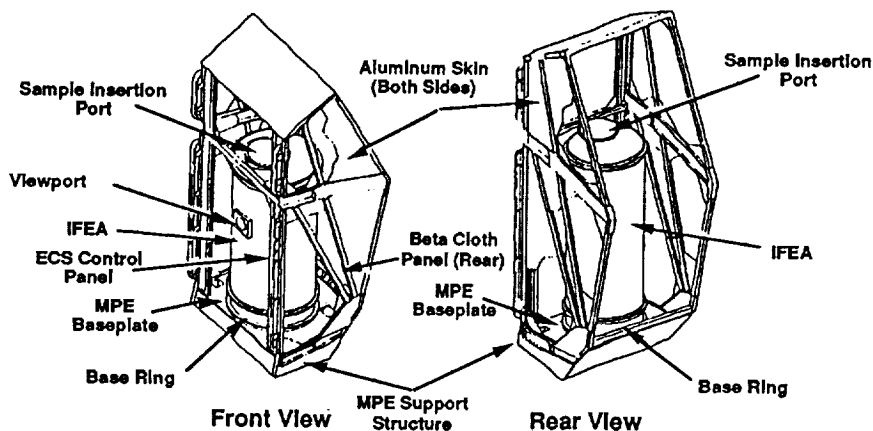

Fig. 4. CGF System Configuration for USML-2.



Note: Glovebox, selected aluminum skin panels, and rear crossbrace not shown for clarity.

Fig. 5. IFEA Mounting in CGF Support Structure.

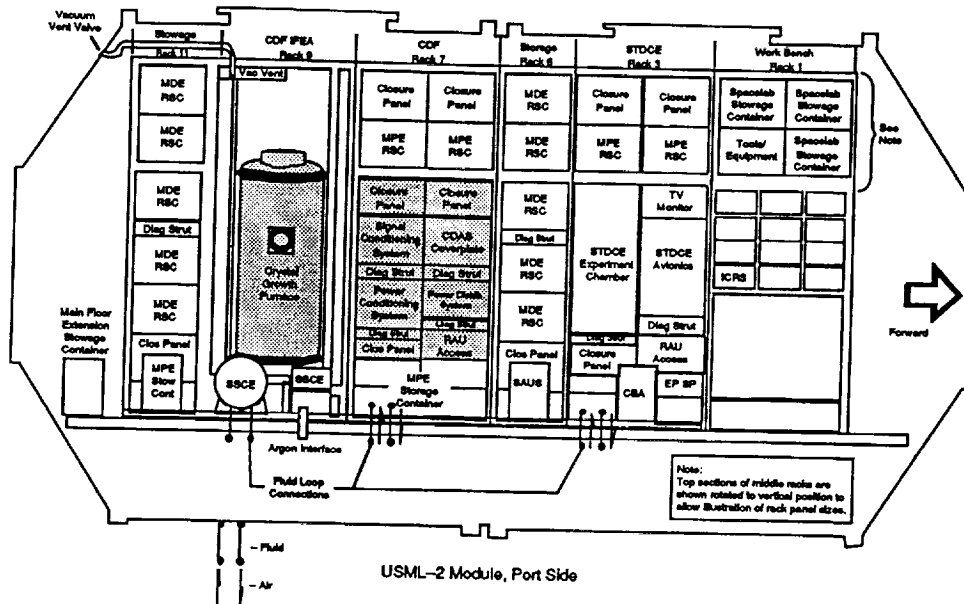

Fig. 6. CGF System Layout in the Spacelab Module.

The avionics boxes are mounted in a standard Spacelab double rack (rack 7), which is located next to the special IFEA support structure (rack 9).

To accommodate the processing requirements of the four multidiscipline crystal growth experiments and an IDFT experiment, the following RFM configuration is used for the USML-2 mission:

- 2.0-cm-thick gradient zone
- 0.025-cm-thick Pt10%Rh heat extraction plate
- S-type thermocouples for heater control.

Table II summarizes the system capabilities.

Table II. CGF System Capabilities.

Reconfigurable Furnace Module	
Hot Zone Temperature	150-1600 °C
Cold Zone Temperature	150-1300 °C
Booster Heater Temperature	150-1700 °C
Gradient Zone Length	0.5-7.0 cm (Inside diameter may vary.)
	Optional heat extraction plate or thermal control plate
Sample Size	Up to 2-cm diameter, 20-cm length
Heating Rate	Up to 300°C/h
Absolute Control Set Point Accuracy/Stability	±4 - 9 °C (depending on the selected temperature range)
	±0.5 °C
Furnace Translation Rate	0.0024 - 8.30 mm/min (directional solidification) 1200 mm/min (rapid translation)
Induced Acceleration in the Sample	<10 ⁻⁴ g
Sample Interface Demarcation	Mechanical Pulsing: Up to 1.0 g Current Pulsing: - In accordance with the capability defined in Figure 1 - Both ± polarity
Processing Atmosphere	Argon
Number of Sample Thermocouples	Up to six per sample (type B, K, or S; can be mixed)
Sample Exchange Mechanism	Capability to hold up to six samples
Crew Interaction for Manual Exchange of Samples	Provision of Flexible Glovebox
Safety Features	Sufficient levels of containment provided to be able to process toxic samples
Real-Time Interaction via POCC	By means of uplink commands

Planned Experiments for USML-2

All the four USML-1 experiments (reference 1) have been chosen for reflight on the USML-2 mission. In addition, an IDFT will be performed to assess the feasibility of interface demarcation in a µg environment and to identify

the effects on interface shape which may be caused by low-level accelerations. The experiment titles and the Investigator teams for the respective experiment are given in Table III.

For USML-2, the experiment processing time will require approximately 360 hours, and the maximum processing temperature will be 1260 °C.

Table III. CGF USML-2 Investigator Teams and Experiments.

INVESTIGATORS	EXPERIMENT
Prof. Herbert Wiedemeier (PI) Rensselaer Polytechnic Institute Troy, NY	Epitaxial Growth of Hg _{0.8} Cd _{0.2} Te on <100> Oriented CdTe Substrate
Dr. Sandor L. Lehoczky (PI) Dr. Frank R. Szofran (Co-I) Dr. Ching-Hua Su (Co-I, USRA) NASA Marshall Space Flight Center Huntsville, AL Prof. Rosalia N. Andrews (Co-I) University of Alabama at Birmingham Birmingham, AL Ms. Lucia Bubulac (Industrial Guest Investigator) Rockwell International Science Center Thousand Oaks, CA	Unseeded Melt-Growth of (Hg,Zn)Te by Directional Solidification
Dr. David J. Larson, Jr. (PI) Dr. Alvin Levy (Co-I) Grumman Corporate Research Center Bethpage, NY Dr. Donald C. Gillies (Co-I) NASA Marshall Space Flight Center Huntsville, AL Dr. R. R. Neugaonkar (Co-I) Rockwell International Science Center Thousand Oaks, CA Dr. Fred Carlson (Co-I) Clarkson University Potsdam, NY Dr. Iwan J. D. Alexander (Co-I) University of Alabama in Huntsville Huntsville, AL	Seeded Bridgman Growth of Zinc-Doped CdTe by Using Bridgman-Stockbarger Method
Dr. David H. Matthiesen (PI) Case Western Reserve University Microgravity Materials Science Laboratory NASA Lewis Research Center Cleveland, OH Mr. Dale Watring (Co-I) NASA Marshall Space Flight Center Huntsville, AL Mr. James Kafalas (Co-I) Viable Systems, Inc. Medfield, MA	The Study of Dopant Segregation Behavior During the Growth of Selenium-Doped GaAs in Microgravity

Interface Demarcation Flight Test

INVESTIGATION COORDINATORS	EXPERIMENT
Dr. Manfred Lichtensteiger (USRA) Dr. Frank Szofran (MSFC) CGF Project Scientist	Interface Demarcation Flight Test (IDFT) - Single Crystal Growth of Gallium-Doped Germanium (Ge:Ga) by Directional Solidification

A brief description of the planned experiments is given below:

Epitaxial Growth of Hg_{0.8}Cd_{0.2}Te on <100> Oriented CdTe Substrate

Objectives: The experiment is designed to study the transient phenomenon that occurs following the initial nucleation through the attainment of steady state. Such transient experiments are of fundamental scientific importance for crystal growth. The expected results of this experiment, which would be a direct follow-up of the USML-1 experiments, include the following:

- Quantitative determination of the effects of microgravity on the growth rate and the composition profile of the

layers as a function of time and average composition of the surface.

- Observation of the effects of microgravity on the surface morphology during the initial growth periods as a function of time.
- Observation of the degree of "mis-orientation" of the epitaxial layer (as a result of lattice mismatch relative to the substrate) as a function of transport time (layer thickness).
- Information on the influence of "off-orientation" of the substrate (e.g., from <100>) on surface morphology (waviness) as a function of layer thickness could be obtained.

As indicated above, the proposed transport experiment is very basic and is expected to provide valuable information for the time dependence of mass transport and growth phenomena during the early stages of growth. A quantitative comparison of several of the above properties for ground control and space crystals will delineate the effects of residual convective contributions on these properties. Combined with the USML-1 experiments for growth times of 6 and 8 hours, the results of the planned USML-2 experiment for 2 to 4 hours' growth period will yield functional relationships (trends) for all the above properties. This will considerably enhance the reliability of these observations.

SACA Configuration: The ampoule is made of fused silica (quartz). The sample consists of HgCdTe source material, and the substrates is $\langle 100 \rangle$ oriented CdTe single crystal wafer. Mercury iodide (HgI₂) is used as the transport agent. There are six K-type thermocouples placed to monitor the temperature of the source, the substrate, and the temperature at other points along the ampoule. The ampoule is placed inside an Inconel cartridge, and the cartridge is sealed.

Unseeded Melt-Growth of (Hg,Zn)Te by Directional Solidification

Objectives: The planned experiment is nearly identical to the experiment that was prematurely terminated on USML-1. Some of the experimental parameters are being fine-tuned based on the partial results from the USML-1 experiment and additional ground-based optimization studies. The experiment consists of melting Hg_{0.84}Zn_{0.16}Te alloy and growing a portion of the total length of the sample on the ground (either in the GCEL unit or at MSFC facilities) by the Bridgman method and quenching the sample. This preprocessed sample will become the flight sample to be processed in the μ g environment. On orbit, the sample will be back-melted to the original interface, and the next portion of the crystal will be grown for a duration allocated for the on-orbit experiment. The specific objectives for the USML-2 phase of the investigation are as follows:

- To back-melt a preprocessed Hg_{0.84}Zn_{0.16}Te solid solution alloy ingot and grow a 2.0-cm alloy crystal under nearly diffusion-limited and stabilizing gravity conditions using a modified Bridgman growth method.
- To reaffirm that preprocessed HgZnTe alloy crystals can be successfully quenched, back-melted, and regrown maintaining nearly steady-state compositions.
- To freeze in the diffusion boundary layer under controlled solidification conditions and from analysis of the boundary layer composition verify the value for the HgTe-ZnTe interdiffusion coefficient for the $x = 0.16$ alloy composition.
- To use the quenched interface shape data, the measured radial variations in composition, and the measured diffusion coefficient to assess the extent of residual fluid flow effects.
- To perform detailed microstructural, electrical, and optical characterization on both the ground-grown and space-grown portions of the crystal, and obtain assessment of reduced gravity effects for the USML-2 crystal growth conditions.
- To perform detailed characterization of the rapidly frozen portions of the ingot to assess the potential benefits of the reduced gravity environment for obtaining homogeneous alloy castings.

SACA Configuration: The ampoule is made of fused silica (quartz). The sample material, Hg_{0.84}Zn_{0.16}Te, is enclosed inside the ampoule and supported at the bottom by quartz wool. Six K-type thermocouples are used to monitor the sample temperatures. The ampoule is placed in an Inconel cartridge and sealed.

Seeded Growth of (Cd,Zn)Te by Directional Solidification

Objectives: The planned experiment is nearly identical to the experiments that were performed on USML-1. Two different ampoule configurations will be used for the USML-2 experiment development. The specific objectives for the USML-2 phase of the investigation are as follows:

- To quantify the effects of the μ g environment on the mechanical strain and defect distribution within the (Cd,Zn)Te crystal. The approach involves the development of a model of the quasi-steady-state thermomechanical stress field and the comparison of the predicted stress fields with quantitative measurements from well-characterized one-g and μ g samples.
- To empirically and analytically investigate the dislocation and defect content of one-g and μ g processed crystals and to relate the defects to growth conditions.
- To quantitatively examine the transport conditions using numerical models. These models focus on the prediction of the μ g transport conditions in order to assess the sensitivity of the experiment to the acceleration environment and the effect of thermal and gravitational asymmetry on one-g and μ g transport.

SACA Configuration: The (Cd, Zn)Te sample consists of a high quality (111) seed crystal which is in contact with a (Cd, Zn)Te bulk. The sample (seed and bulk material) is enclosed in an evacuated, fused silica ampoule that has internal carbon nonwetting coating. The ampoule is instrumented with six K-type thermocouples and integrated into a WC-103 cartridge coated inside and outside with chrome-iron silicide and sealed.

Seeded Crystal Growth of Selenium-doped Gallium Arsenide (GaAs:Se) by Directional Solidification

Objectives: The experiment is designed to specifically characterize and controllably modify the melt-solid interface shape during the growth to achieve uniform radial segregation of the dopant in the solid. This experiment will be a direct follow-up of the USML-1 experiments which focused on obtaining axial dopant uniformity. In the planned experiments, the booster heater and the gradient zone configuration of the RFM will be used to achieve a planar or near-planar interface shape in order to minimize radial dopant variation. Since control of the interface shape during the growth is the principal goal of the USML-2 experiments, it is necessary to measure the interface shape during growth. The technique of interface demarcation by current pulsing (Peltier pulsing) will be extensively used. This technique has been used successfully to determine the segregation behavior of semiconductors on a microscale. Thus, these experiments are expected to provide new and important experimental data for the continuation and upgrading of heat transfer and fluid-flow models on a commercially important semiconductor material system. The current requirement for the pulses will be based on obtaining the necessary current density in a 1.50-cm diameter sample to establish the interface demarcation.

SACA Configuration: The ampoule is made of fused silica (quartz). The growth boule (sample material), selenium-doped gallium arsenide, is enclosed inside a pyrolytic boron nitride (PBN) sleeve. The PBN sleeve is closed at one end by means of a graphite pedestal, and the other end has a graphite chamber in which a graphite plunger is provided to support a PBN leaf spring to allow expansion of the boule volume. The graphite contacts have molybdenum wire contacts attached to them. This assembly is hermetically sealed by sealing the ampoule around the molybdenum foil of the feedthrough. These feedthroughs terminate in a loop where the interface demarcation current leads are attached. The sample ampoule is integrated into the specially configured CPID SACA. The SACA is backfilled with argon to a desired pressure and sealed. Six S-type thermocouples are located inside the SACA to monitor experiment processing.

IDFT: Growth of Ge:Ga by Directional Solidification

Objectives: This flight test is designed to assess the feasibility of interface demarcation in a microgravity environment and to identify the effects on interface shape which may be caused by low-level accelerations. Since control of the interface shape during growth is a significant goal of three of the USML-2 experiments, it is necessary to measure the interface shape during growth. This test is designed to characterize the melt-solid interface shape during the growth process. For the USML-2 mission, current pulsing (Peltier pulsing) will be the technique of interface demarcation. The current requirement for the pulses will be based on obtaining the required current density in a 1.40-cm diameter sample.

SACA Configuration: The ampoule is made of Ge#214 fused silica (quartz). The growth boule (sample material), Ge:Ga, is enclosed inside this ampoule between two graphite cups. These cups serve as current contacts for interface demarcation. The graphite cups have platinum wire contacts which are spot-welded to molybdenum foil. Each molybdenum foil forms a hermetic seal where it passes through the end of the quartz ampoule. Spot-welded to the molybdenum foil outside the ampoule is another platinum wire which terminates in a loop where the interface demarcation current leads are attached. The sample ampoule is integrated into the specially configured CPID SACA and sealed. Six S-type thermocouples are located inside the SACA to monitor experiment processing.

Experiment Processing Scenario for USML-1

The experiment processing scenario for the USML-2 mission is defined below:

- Twelve (SACAs) samples will be carried on board as stowed items.
- Six selected samples will be manually loaded into the SEM by a crewmember following CGF activation and preparation for manual sample exchange.
- Processing of the samples in the predefined sequence will then be performed automatically, and five samples will be nominally processed.
- Upon completion of processing, the processed SACAs will be retrieved by a crewmember and restowed for the return flight.

Summary

The Crystal Growth Furnace was designed and developed to support the United States Microgravity Laboratory (USML) and Microgravity Science Laboratory (MSL) flight opportunities for microgravity research and performed flawlessly on its maiden flight on the USML-1 mission. The flight and prototype ground systems have undergone extensive modifications and enhancements in order to provide better operational flexibility in achieving scientific objectives and to increase programmatic confidence. The CGF has demonstrated the capability for supporting needed research and development in a microgravity environment on various important electronic and photonic materials of interest. This sophisticated second generation high temperature processing facility is providing the means for furthering the understanding of the complex phenomena inherent with both diffusion controlled and vapor transport growth and will lead to significant improvement of processes and materials for future applications.

The important CPID upgrade for the USML-2 mission will enable the investigator to mark the growth interface during processing in order to determine more precisely growth rates and interface shape within the melt, and will increase the science yield from the flight. In addition, the information provided by the CPID experiment and flight test

will not only serve to characterize the melt-solid interface shape during the growth process, but will also denote the effects on interface shape caused by low level accelerations imposed by various Orbiter attitudes during processing.

The four reflight experiments are proposed from both private industry and leading research institutions. They were selected from a peer review process and represent the leading flight research programs in this country. The experiment and investigation teams have been working diligently and tirelessly in analyzing the previous flight results and in conducting ground-based testing in an attempt to carry their scientific investigations to the highest level.

The requirements of materials technology development continues to provide the impetus for the continually improving furnace facilities to be utilized in a microgravity environment. The evolution of furnace facilities such as the CGF with its current enhancements and upgrades, while currently an R&D development, offers new and expanded options for the characterization, development, and exploitation of new materials to meet future commercial and industrial needs. Understanding these processes that occur in microgravity will greatly enhance the technology base for the development of important electronic and photonic semiconductor materials.

Significant research findings have resulted from directional solidification growth experiments conducted in a microgravity environment and compared to terrestrially grown crystals. Crystals grown by chemical vapor transport in a microgravity environment have also demonstrated improved crystal morphology, lower defect densities, and higher growth rates than demonstrated in ground-based processing.

The planned series of USML and MSL flights require the transportation of the processing facility into Earth orbit on each mission. With the concept of free-flyers or Space Station furnace facilities, longer processing time will be available which will greatly expand the technology base for accommodating materials research. This will afford the opportunity for processing a greater number of different samples and for processing new materials requiring much slower growth rates with more precisely controlled timelines.

The CGF furnace, as it has evolved, is currently manifested as a primary payload on the USML-2 mission scheduled for launch in mid-September 1995. In addition, the facility has also been recently manifested as part of the payload complement on the MSL-1 flight now scheduled for launch in early 1997. A derivative of this design capability is currently being developed to fly on the Space Station and will provide a valuable resource and a long-term and continuing capability for the United States for materials research and development well into the next century.

Acknowledgment

The authors wish to acknowledge the PIs and the MSFC Project Scientist for their help. Special thanks are extended to Ms. Kay Parker, Ms. Nancy McMahon, and Ms. Becky Taylor for preparing the manuscript.

References

1. Srinivas, R., and Schaefer, D.A., "Crystal Growth Furnace: An Overview of the System Configuration and Planned Experiments on the First United States Microgravity Laboratory Mission," *Acta Astronautica*, Vol. 28, pp 227-238, 1992.
2. Fiske, M. R., and Stark, J. D., "Materials Compatibility Issues in the Development of a Cartridge for Microgravity Processing of Gallium Arsenide," 7th Alabama Materials Research Conference, Huntsville, Alabama, September 1993.