

NASA/CR - 1998- 208171

1N-46-CR

137217

---

**ROCKET/RADAR INVESTIGATION OF LOWER IONOSPHERIC  
ELECTRODYNAMICS ASSOCIATED WITH INTENSE MID-  
LATITUDE SPORADIC-E LAYERS**

---

## **A Grant Renewal Progress Report**

**Submitted to:**

**NASA/Wallops Flight Facility  
Building F6  
Wallops Island, VA 23337**

**By:**

**The University of Texas at Dallas  
William B. Hanson Center for Space Sciences  
P.O. Box 830688, M/S FO2.2  
Richardson, Texas 75083-0688  
(972) 883-2851**

**Employer's Identification Number: 75-1305566  
Congressional District: Third**

**Principal Investigator:**



**Dr. R. A. Heelis  
Director, William B. Hanson Center for Space Sciences  
The University of Texas at Dallas  
(972) 883-2822**

**MAY 1998**

# **ROCKET/RADAR INVESTIGATION OF LOWER IONOSPHERE ELECTRODYNAMICS ASSOCIATED WITH INTENSE MID-LATITUDE SPORADIC-E LAYERS**

## **Background**

Sporadic layers, which appear in the region from 100 km to 120 km are thought to be formed by convergent Pedersen drifts induced by altitude gradients in the zonal neutral wind. In this altitude region NO<sup>+</sup> and O<sub>2</sub><sup>+</sup> are the major ions produced by photoionization and charge exchange of atmospheric and ionospheric species. The relative composition of atmospheric ions and meteoric ions in sporadic layers is important in determining their persistence, the time scales for formation, and the electrical conductivity of the layers. This rocket investigation will include a diagnosis of the neutral wind field and the electric field distribution. Coupled with ion composition measurements we will be able to expose the relevant formation mechanisms and the electrodynamic consequences of their existence. A rocket trajectory has been chosen to provide substantial horizontal sampling of the layer properties and knowledge of the horizontal gradients in composition and density are essential to determine the polarization electric fields that may be associated with ionospheric layers. The University of Texas at Dallas (UTD) is responsible for designing, building, and operating the ion mass spectrometers included on these rockets. The following provides a summary of the UTD accomplishments in the second year of the project as well as a description of the plans for the third year's activities. The UTD mass spectrometer acronym has been coined as PRIMS for Puerto Rico Ion Mass Spectrometer.

## **Progress During Reporting Period**

Electrical, mechanical package, mass spectrometer, vacuum system, and ground support equipment detailed designs were completed. The balance of all parts and materials were ordered and received. This enabled fabrication and assembly of the systems to be completed within the schedule requirements. Figure 1 shows the PRIMS instrument in flight configuration. The Critical Design Review (CDR) was held June 18, 1997 at WFF. UTD prepared summary documents to well-define the payload and ground support requirements needed to support PRIMS. This included access doors (both fixed and flight opened), pyro circuits and monitors, power requirements, mass definition, timing events, telemetry requirements, timing signals, deployment events, access requirements, ground support, environmental testing, and launch pad support. Also mechanical drawings of the PRIMS package and payload accommodation were included. Figure 2 shows PRIMS mounted into the payload and Figure 3 shows the installation configuration utilized to place PRIMS into the payload. There were no action times imposed on the UTD/PRIMS team as a result of the review.

Later in this period UTD successfully performed all of the PRIMS level pre-environmental testing on the flight instruments and associated ground support systems. The required environmental testing of the instruments was performed at WFF with attending UTD personnel. The PRIMS opening device (See Figures 4 & 5.) with associated squibs had some problems that were successfully solved. The Memorandum dated February 24, 1998 and attached to this report summarizes those problems and the solutions as worked out with WFF personnel. PRIMS was successfully integrated into the payload and completed all system level testing. The payloads and associated equipment were shipped to the Tortuguero Range in Puerto Rico. Payload #21.115 was successfully launched on March 25, 1998 with attending UTD personnel supporting the PRIMS instrument.

### **Plans For Next Reporting Period**

The quicklook data from the 21.115 PRIMS flight indicate very successful operation. The payload door deployed, the PRIMS cover opened, the PRIMS high voltage came on, and data was received on the three science channels. The attached sample quicklook data record (Figure 6) shows the PRIMS High Mass data channel (S2-1, AMU56), Mid Mass (S2-2, AMU30 and 32), and Low Mass (S2-3, AMU24) with the expected roll modulation. The data shown were taken as the downleg E-layer was encountered. The Mid Mass (MM) channel measures AMU30 most of the time, but switches to AMU32 for 32 samples about every 8 seconds. (Every 8000 samples, sample rate = 1041.5 samples/sec). To allow for settling time and to flag the event, the MM data is set to all bits high (1023) for four samples before and for four samples following the AMU32 measurement. The switch between masses can also be seen in the analyzer high voltage monitor.

As can be seen in the data record, the counters for HM and MM overflowed at times during the flight. This effect can easily be removed from the data by adding a multiple of 1023 counts to make the spin modulation of the data a continuous function. Of course, during the third year of this grant, we plan to reduce the data to geophysical parameters, coordinate with the Principal Investigator and other experimenters, and to publish the results.

It appears that the presence of demonstrators combined with a small science window have stopped the opportunity to launch payload 21.116 from Puerto Rico. The plans for the subsequent launch of 21.116 will be determined by NASA Headquarters personnel and the Principal Investigator, Dr. Rob Pfaff of GSFC.



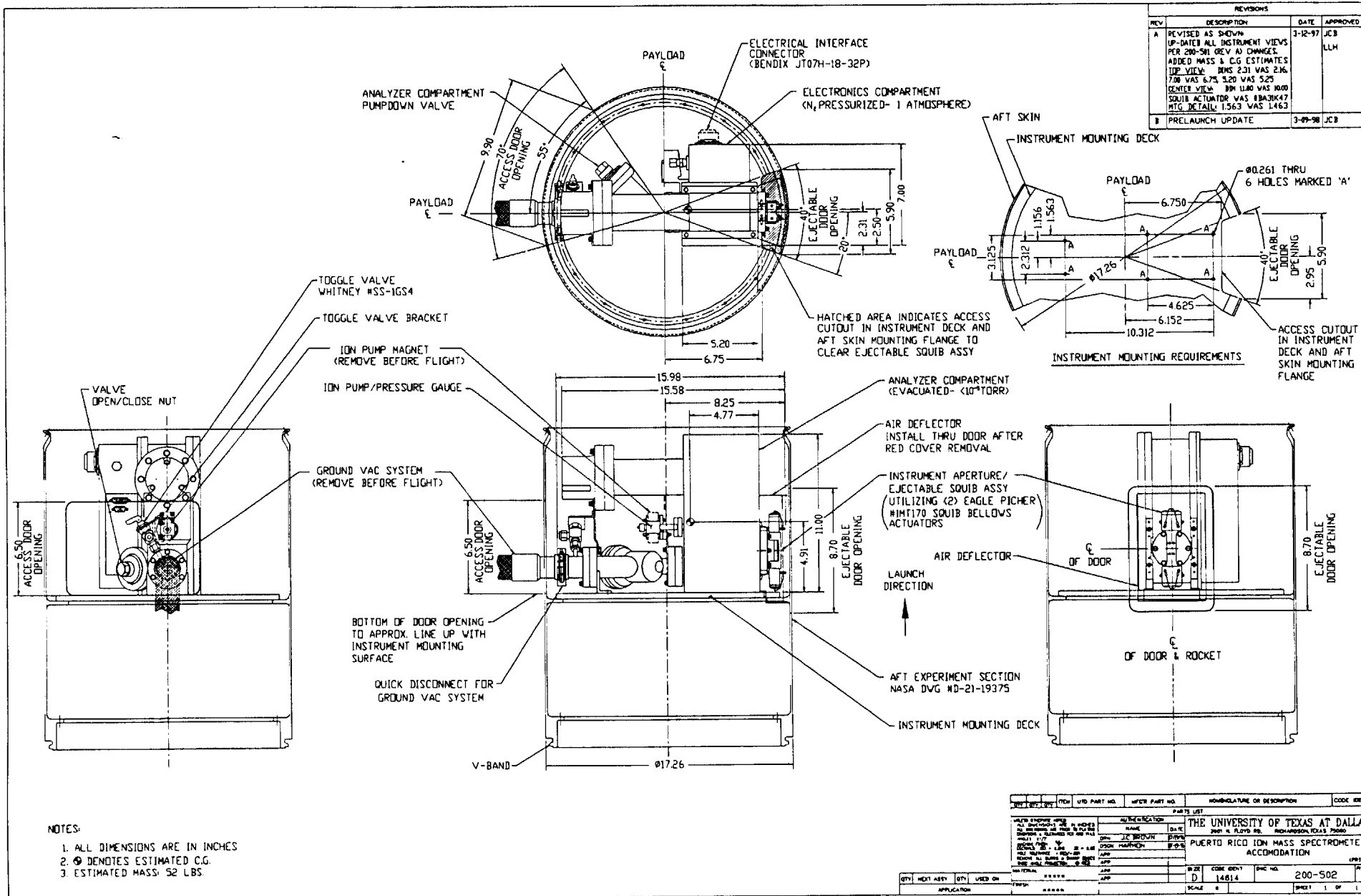
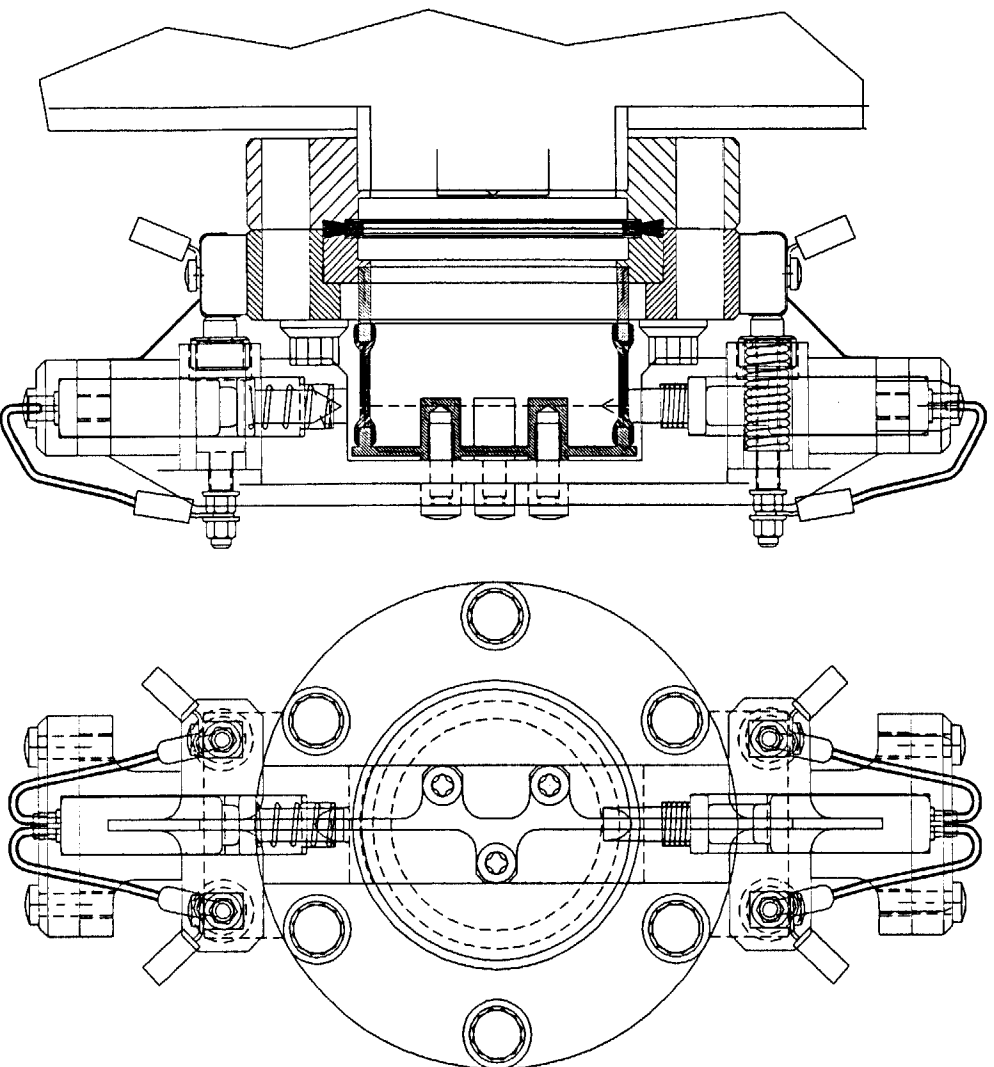
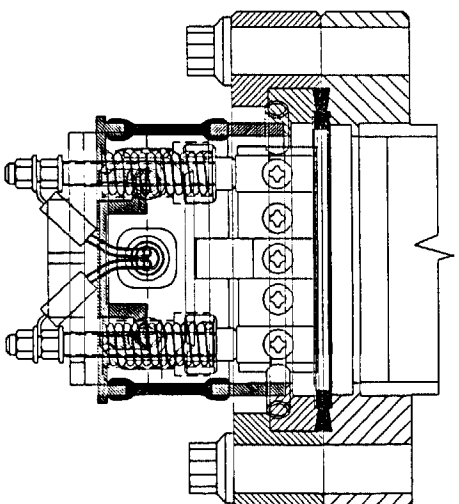

FIGURE 2





PRIMS OPENER ASSY

FIGURE 4

1.00 in  
SCALE



SQB-ASSY

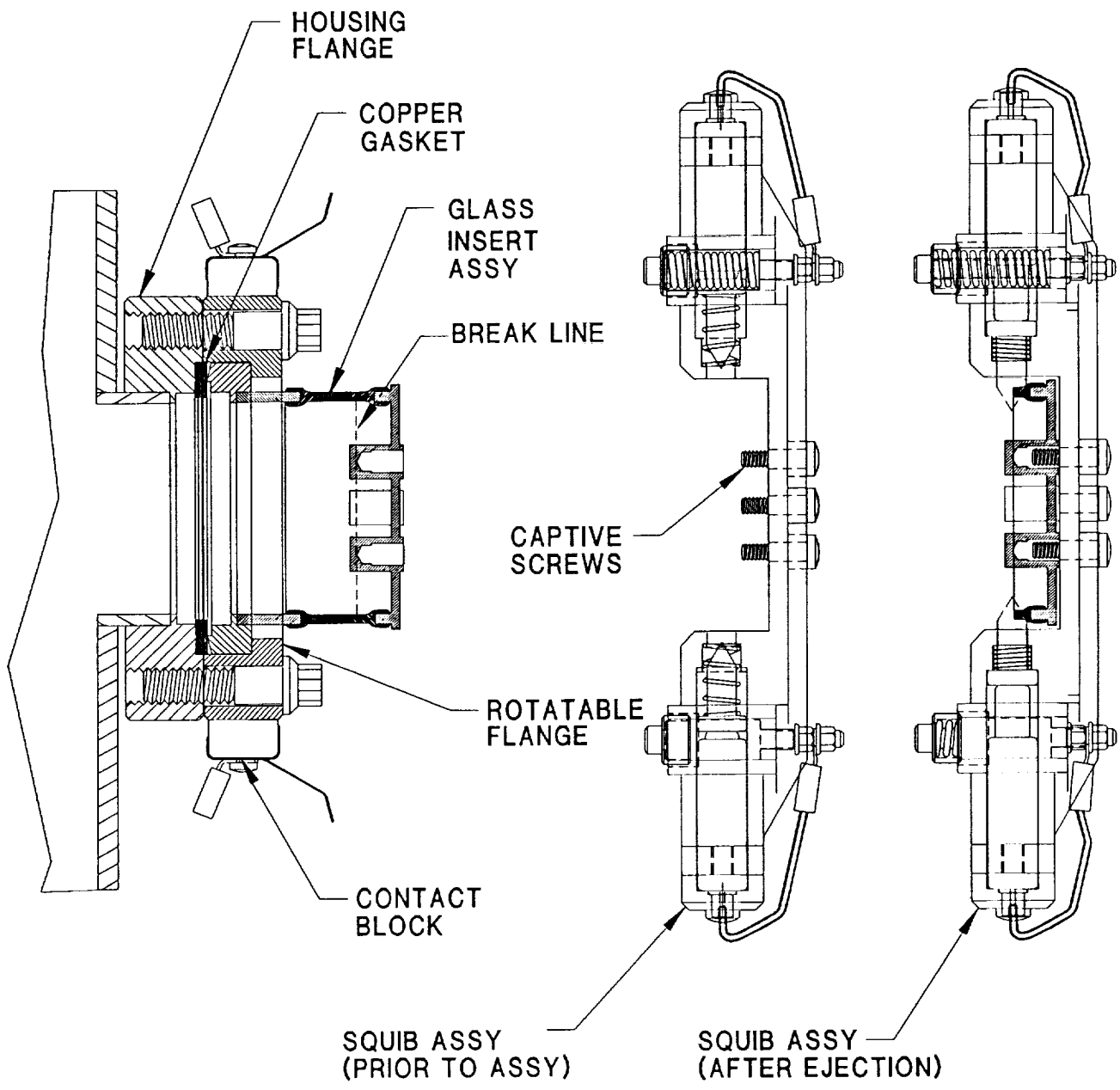

PRIMS OPENER ASSY

FIGURE 5



1.00 in  
SCALE



h Voltage

A38 Analyzer High Voltage

A39 BaroSwtich

ature Monitor

A40 Getter Temperature Monitor

ectrometer 1

S2-1 Ion Mass Spectrometer 1

250

 Astro-Med, Inc.

MT-95000 MULTI-TASK RECORDER

ectrometer 2

S2-2 Ion Mass Spectrometer 2

ectrometer 3

S2-3 Ion Mass Spectrometer 3

Monitor

PD4-8 PRIMS Door Monitor

PRIMS Quick-Look Data Sample

PRIMS Door Deploy

Figure 6

A129 Squib #1 PRIMS Door Deploy



## THE UNIVERSITY OF TEXAS AT DALLAS

WILLIAM B. HANSON CENTER FOR SPACE SCIENCES  
BOX 830688 MS FO22 RICHARDSON, TEXAS 75083-0688  
2601 N. FLOYD ROAD, RICHARDSON, TEXAS 75080  
(972) 883-2851 FAX (972) 883-2761  
INTERNET - [cssmail@utdcss.utdallas.edu](mailto:cssmail@utdcss.utdallas.edu)

### Memorandum

DATE: February 24, 1998

TO: Dr. Robert Pfaff  
Goddard Space Flight Center

FROM: Larry Harmon *LH*  
PRIMS Mechanical Engineer

SUBJECT: *PRIMS VACUUM OPENER TESTING AND QUALIFICATION*

The PRIMS Vacuum Opener consists of a glass vacuum seal over the entrance to the PRIMS instrument that is broken (opened) and ejected by a dual, explosive bellows actuator/chisel mechanism during flight. (See Figures 1, 2, & 3.) Qualification units of this opener have been subjected to various tests to demonstrate its flight readiness. A brief summary of those tests, along with notations of problems encountered and corrective actions taken, are listed below. more detailed discussions of some of the items are contained in the failure analysis that I sent to Rod Heelis and Greg Earle 28 Jan 98 and that Greg sent on to you on 2 Feb 98.

1. Static bench test firing of a single pyro and successfully opening and deploying of the PRIMS vacuum cover two separate times.
2. Successful vibration testing at WFF of two Qual Units with dummy pyros (demonstrated ability of glass seal to survive launch).
3. Vibration and spin deployment testing at WFF (vibration successful, spin deployment failed). See the failure analysis for details.
4. Successful static deployment of "thick" glass seal that had failed to break during WFF spin deployment test. (New, hardened chisels used.)
5. Retest vibration and spin deployment of Qual Model at WFF. Successful vibration and spin deployment. However, one pyro failed to fire.
6. Discovered our pyros from a bad lot. Acquired new pyros from a new improved design lot from Eagle-Picher. Had x-rayed.
7. Successful vibration and static deployment of Qual Model with new pyros at WFF. First pyro broke glass & deployed cover. Second pyro fired to build confidence in vibration survivability.

We feel that, after much discussion with the pyro manufacturer, Eagle-Picher, and with the WFF contract x-ray facility at the Naval Weapons Station in Yorktown, VA, we completely understand the problems that we have encountered during the qualification of the PRIMS Vacuum Openers. These conversations and the many tests conducted were very enlightening. We are grateful for the timely cooperation of Eagle-Picher, the Naval Weapons Station and Wallops Flight Facility (Ted Gass in particular) for helping us to arrive at the point where we have a high degree of confidence that the openers will operate as required in flight. We plan to use only pyros from the new lot for flight. X-rays of all of these pyros have been delivered to WFF by the NAVWEPS Station. The pyros have also been 100% x-rayed, inspected and tested by Eagle-Picher.

## Attachments

cc: Rod Heelis - UTD  
Greg Earle - UTD  
Ron Lippincott - UTD  
Ben Holt - UTD  
J. C. Brown - UTD  
Steve Skees - WFF  
Ted Gass - WFF

YEARLY BUDGET SUMMARY

THIRD YEAR BUDGET AND PERSONNEL SUMMARY BREAKDOWN

TITLE: Rocket/Radar Investigation of Lower Ionospheric Electrodynamics Associated with Intense Mid-Latitude Sporadic-E Layers

PRINCIPAL INVESTIGATOR & INSTITUTION: Roderick A. Heelis; The University of Texas at Dallas

SUMMARY OF THIRD YEAR PROPOSED COSTS: (nearest \$K)

1.	SALARIES AND WAGES .....	\$ 5
2.	SUPPLIES AND MATERIALS .....	0
3.	EQUIPMENT PURCHASES .....	0
4.	COMPUTER TIME (paid with PI funds) .....	0
5.	SERVICES .....	0
6.	PUBLICATIONS AND COMMUNICATIONS .....	0
7.	TRAVEL .....	4
8.	OTHER (INCLUDING BENEFITS AND OVERHEAD) .....	6
9.	TOTAL FULL DURATION BUDGET .....	\$ 15

SUMMARY OF STAFFING REQUEST (NEAREST \$K, NEAREST 0.1 MANYEAR)

1.	SENIOR PERSONNEL: Heelis, Hoffman, Coley	.0 my	\$ 3
2.	POSTDOCTORATE ASSOCIATE: 1	.1 my	2
3.	STUDENTS: 0	.0 my	0
4.	TECHNICAL SUPPORT:	.0 my	0
5.	OTHER	.0 my	0
6.	TOTALS	1 my	\$ 5

EXPECTED SUPER COMPUTER USAGE

1. LOCATION AND TYPE FOR EACH COMPUTER: N/A
2. ESTIMATED NUMBER OF COMPUTING UNITS: 0
3. IF GSFC/NASA NCCS IS PROPOSED, LIST ESTIMATED NUMBER OF CU'S: 0