

NASA/CR. - 76. - 207574

NCC3-502

IN-80-CR  
077913



NASA-ASEE



AMERICAN SOCIETY FOR ENGINEERING EDUCATION

1996  
SUMMER FACULTY  
FELLOWSHIP  
PROGRAM  
AT  
NASA LEWIS  
RESEARCH CENTER

FINAL REPORT



NASA-ASEE SUMMER FACULTY FELLOWSHIP  
PROGRAM  
AT  
NASA LEWIS RESEARCH CENTER  
Cleveland, Ohio

PREPARED BY THE CODIRECTORS:

JOSEPH M. PRAHL  
PROFESSOR AND CHAIR,  
DEPARTMENT OF MECHANICAL AND AEROSPACE ENGINEERING  
CASE WESTERN RESERVE UNIVERSITY

THEO G. KEITH, JR.  
VICE PRESIDENT, WORKFORCE ENHANCEMENT  
OHIO AEROSPACE INSTITUTE

FRANCIS J. MONTEGANI  
CHIEF, OFFICE OF UNIVERSITY PROGRAMS  
NASA LEWIS RESEARCH CENTER



## Contents

Introduction	3
Appendix A 1996 Seminar Series	7
Appendix B Summary of Participants' Research	11
Agrawal, Om P.	13
Bever, Steven J.	15
Boyd, Darwin L.	17
Cala, Martin	19
Cheung, Harry M.	23
Choi, Mun Young	25
Jensen, Kirk A. (Accompanying student of Professor Choi)	27
Cios, Krzysztof	29
Crane, David L.	31
Donovan, Richard P.	33
Elbuluk, Malik E.	37
Emrich, Carol L.	39
Flanagan, Patrick M.	41
Gruhlke, Russell W.	43
Hampton, Roy D.	45
Heminger, John A.	47
Hubbard, Danny E.	49
Ibrahim, Mounir B.	51
Izen, Steven H.	53
Jadaan, Osama M.	55
Jeng, San-Mou	57
Opalski, Anthony B. (Accompanying student of Professor Jeng)	59
Johnson, Andrea L.	61
Johnson, Roger H.	63
Jones, Kenneth M.	65
Kaufman, Miron	67
Lau, Sai C.	71
Lin, Paul P.	73
Lin, Yueh-Jaw	75
Lock, James A.	77
Mann, Jr., Adin	79
Naraghi, Mohammad H.	81
Parang, Masood	85
Parker, Robert G.	87
Dziech, Aaron N. (Accompanying student of Professor Parker)	89
Qammar, Helen K.	91
Rashidi, Majid	93
Rooke, Steven P.	97
Ruff, Gary A.	99
Shih, Tom I.	101
Stephens, Mark A. (Accompanying student of Professor Shih)	105
Tanner, Stephen P.	107
Taylor, Thomas W.	109
Tenerelli, Jr., Joseph P.	111
Wayman, Thomas R.	113
Appendix C Evaluation Questionnaire	115

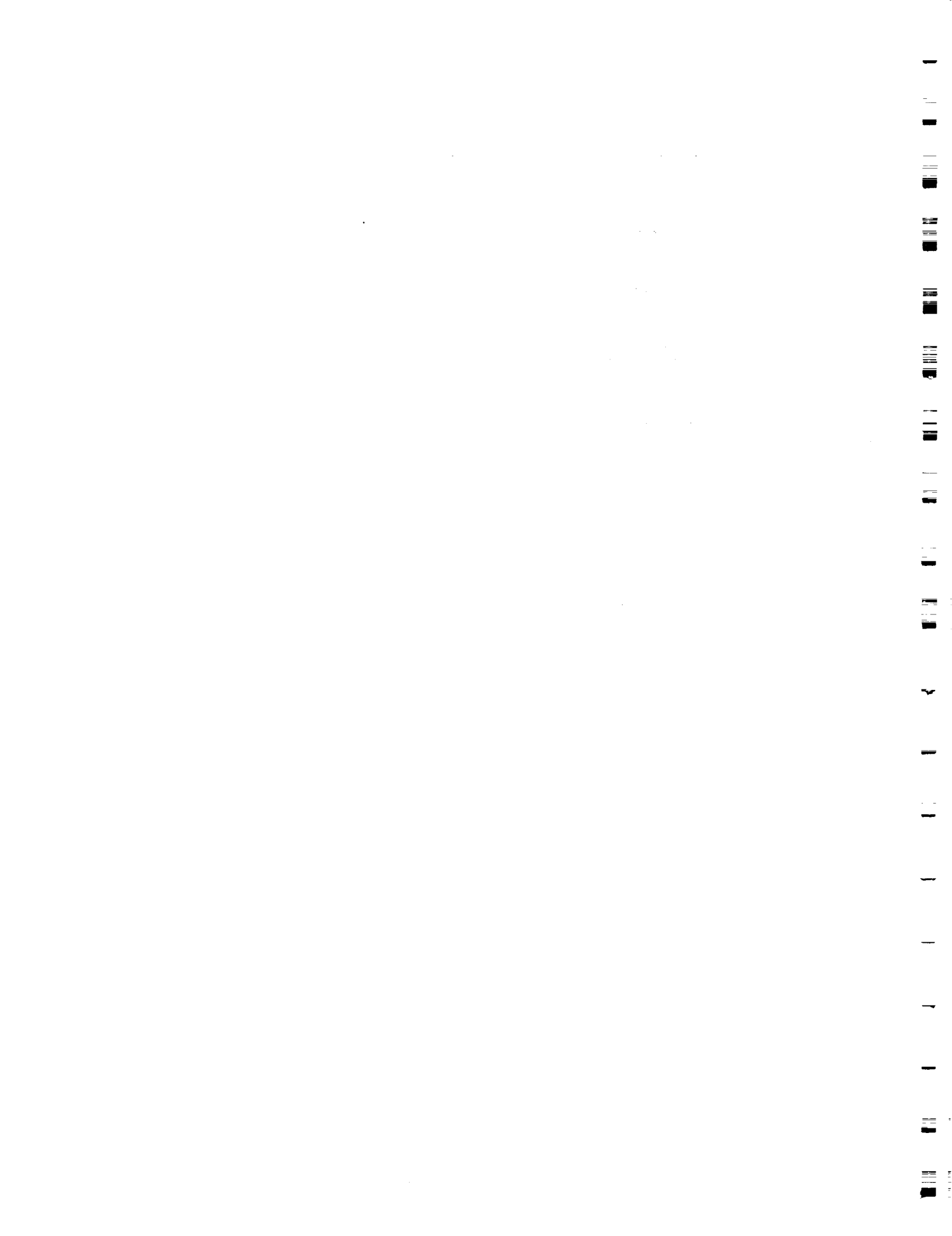

## INTRODUCTION

During the summer of 1996, a ten-week Summer Faculty Fellowship Program was conducted at the NASA Lewis Research Center (LeRC) in collaboration with Case Western Reserve University (CWRU), and the Ohio Aerospace Institute (OAI). This is the thirty-third summer of this program at Lewis. It was one of nine summer programs sponsored by NASA in 1996, at various field centers under the auspices of the American Society for Engineering Education (ASEE).

The objectives of the program are:

- (1) to further the professional knowledge of qualified engineering and science educators,
- (2) to stimulate an exchange of ideas between participants and NASA,
- (3) to enrich and refresh the research activities of participants' institutions.
- (4) to contribute to the research objectives of LeRC

Fellowships are awarded to qualified Faculty members at institutions that are not extensively engaged in aerospace research. Fellows spend ten weeks at LeRC working on research problems under the supervision of Lewis personnel. They also attend lectures and seminars organized by CWRU and OAI. Fellows ordinarily participate in the program for two consecutive summers. The 1996 program began officially on June 3 and continued through August 9, 1996. However, several Fellows actually had program dates which differed from the nominal dates because university schedules vary considerably and because some of the summer research projects warranted a time extension beyond the ten weeks for satisfactory completion of the work.

This report is intended to recapitulate the activities comprising the 1996 Lewis Summer Faculty Fellowship Program, to summarize evaluations by the participants, and to make recommendations regarding future programs.

## ORGANIZATION OF THE PROGRAM

The program was organized and managed by the three Codirectors representing LeRC, CWRU and OAI.

Suitable research tasks for the Faculty Fellows are identified at Lewis by the Lewis Codirector. These tasks are established by consulting with the research supervisors so as to obtain projects that will be challenging to the Fellows, match his or her background and interests, and allow at least a portion of the work to be completed during the summer. Assignments sought are either for participation in an established ongoing program or for a substantial task of limited scope that will pose no equipment problems.

A series of eight lectures were organized for the Fellows by the Codirectors from CWRU and OAI. The list of speakers, dates, and titles of the lectures is included in Appendix A.

## RECRUITING AND SELECTION OF THE FELLOWS

The 1996 Summer Faculty Fellowship Program was announced by ASEE through advertisements in the Journal of Engineering Education. More detailed brochures describing all the programs and application forms were sent out by ASEE Headquarters to those who requested them and to engineering colleges, deans, department heads, etc. LeRC, CWRU and OAI circulated a number of brochures. A number of applications were requested through the OAI Web site. A common application form is used for the programs at all NASA Centers. Applicants are asked to limit their choices to two centers and to indicate their first choice. Applications for the LeRC Program were returned to the CWRU Codirector.

Of the 91 completed applications received, 87 indicated the Lewis program as first choice. The applications were reviewed by the Lewis Codirector who considered the applicant's interests and qualifications as well as the potential value of participation in the program for their institution (supporting letters from deans or department chairs were requested). Selection was made by the Codirectors after screening the applications and then circulating them to the appropriate research supervisors at Lewis for their expressions of interest. Offer letters were sent to 52 selected Faculty explaining each person's research project and identifying the person's colleague. Forty-one first and second year Fellows and four accompanying graduate students accepted for a total of 45 1996 participants as indicated in the table below.

All of the Lewis colleagues were asked to phone or write their Fellow as soon as possible to ensure proper matching of the Fellow to the research project, and to encourage the first-year Fellows to make a visit to Lewis if this appeared beneficial to the project. This early contact has proved very successful in the past. The stipend paid to the Fellows was \$1000 dollars per week and a relocation allowance of \$1000 was paid to those living outside a 50 mile radius of the Center.

A complete list of the Fellows together with their backgrounds, institutions, and research areas is included in Appendix B. Of the 41 1996 Fellows, 39 hold a Ph.D. Of the 28 Engineering Faculty, the breakdown of disciplines is as follows: 20 Mechanical and Aerospace Engineers, 2 Electrical Engineers, 1 Biomedical Engineer, 1 Industrial Engineer, and 1 General Engineer, and 3 Chemical Engineers. Of the 9 Natural Science Faculty, the breakdown is: 5 Physicists, 2 Chemists, and 2 Mathematician/Mathematical Scientists. The distribution of the academic ranks is as follows: 9 Full Professors, 16 Associate Professors, and 12 Assistant Professors.

## HOUSING

Many of the 1996 Fellows found suitable housing for themselves and their families with assistance from a housing list provided by the Ohio Aerospace Institute. The list contains 384 entries (apartments, dormitories, hotels, houses, and rooms) and information concerning distance from LeRC, costs, privileges, etc.



## **SPECIAL EVENTS**

A reception was held at Lewis at the beginning of the second week to enable the Faculty Fellows to with the other Faculty Fellows and their Lewis Colleagues. During the second week of July a family picnic was held for the Fellows and Lewis Colleagues at the Lewis picnic grounds, and at the end of the Program, a dinner was held for the Fellows and Lewis Colleagues aboard the Nautica Queen in downtown Cleveland. These special events helped the group develop a strong identity as Lewis Fellows.

## **EVALUATION**

At the end of the ten-week Program, the Faculty Fellows were asked to critique the program using the questionnaire form shown in Appendix C. An overall evaluation of the program, based on the forms received from Fellows, was performed by the Codirectors. The general impression from the evaluations and from conversations with the Faculty Fellows and their research Colleagues is one of enthusiasm for the program. From their response it appears that the Program has been quite successful in two of its objectives: (1) to further the professional knowledge of qualified engineering and science teachers, and (2) to stimulate an exchange of ideas between participants and NASA.

The third and perhaps most important objective is to enrich and refresh the research activities of the participants' institutions. The reports from this and past years evaluations cited numerous instances where participation in the NASA-ASEE summer programs has led to new courses, new research projects, new laboratory experiments, and grants from NASA to continue the work initiated in the Program at Lewis. Many of the Fellows mentioned amplifying material both in undergraduate and graduate courses based on the summer experience at Lewis. Several mentioned research proposals and grants that grew out of their summer work and anticipate continuing projects at their home institutions on work related to their summer research. A number of 1996 Fellows indicated that proposals to NASA will grow out of their summer research projects. In addition, some journal articles and NASA publications will result from this past summer's activities. Fellows from past summers continue to send reprints of articles that resulted from work initiated at Lewis.

## **RESEARCH SUMMARIES**

Brief summaries of the Fellows' research assignments are also included in Appendix B. As is clear from the reports, some of the work is of sufficient importance and content to warrant reporting in the technical literature.

## **RECOMMENDATIONS**

The following recommendations are based on the above evaluation and on the judgement of the Codirectors:

1. The Program should be continued for another summer.
2. The balance of time between research and other activities, such as lectures, seminars, and laboratory tours should remain approximately 90%-10%.
3. The lecture series should be continued, This years lectures were very interesting and well received. It is proposed to continue the short tours of the Lewis facility.
4. Experience has shown that the pre-summer contact between the Fellows and their Colleagues is an important factor in the success of the program. It is recommended that the early communication be continued with a visit by the first-year Fellows to LeRC prior to the beginning of the Fellowship.

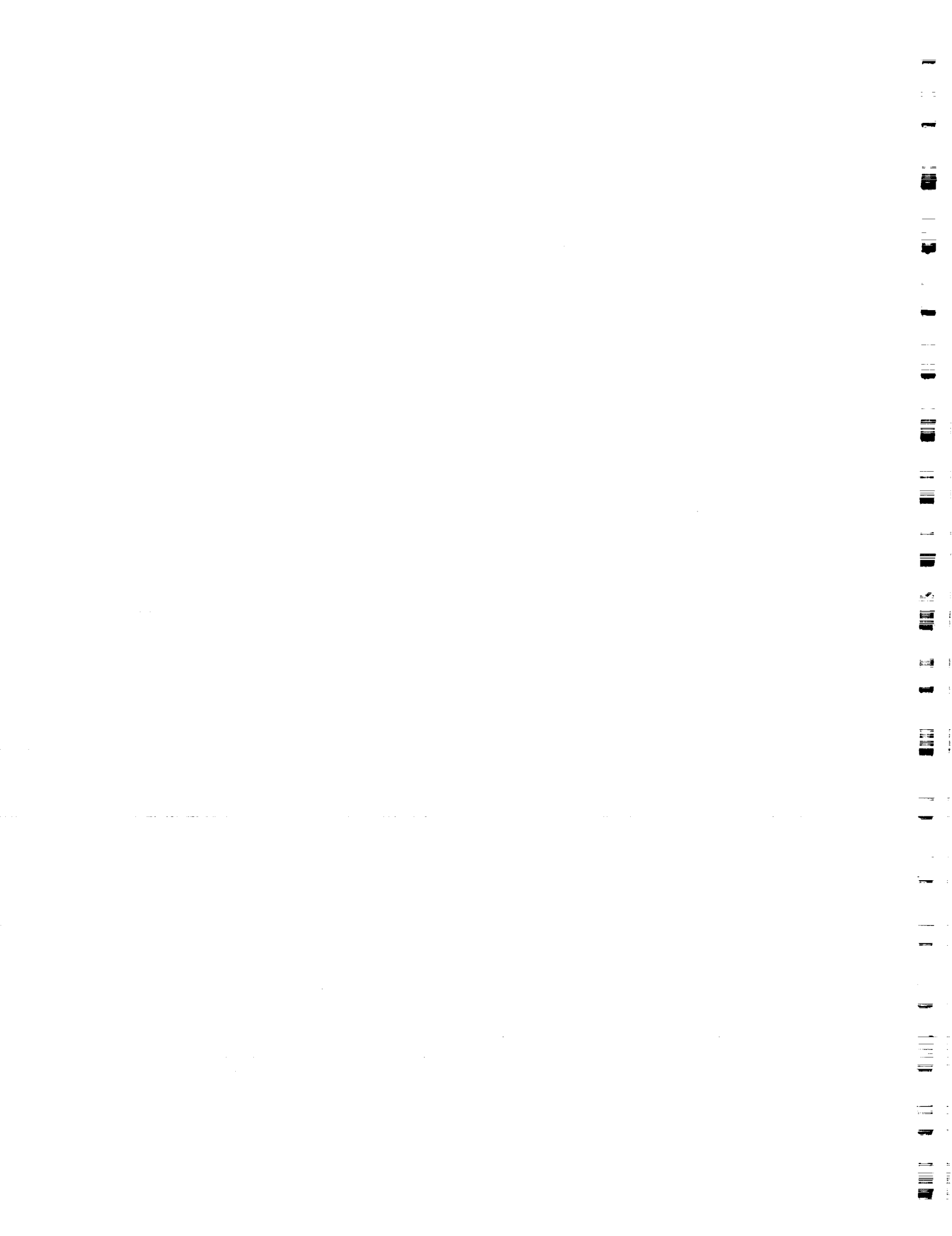

APPENDIX A

1996 SEMINAR SERIES

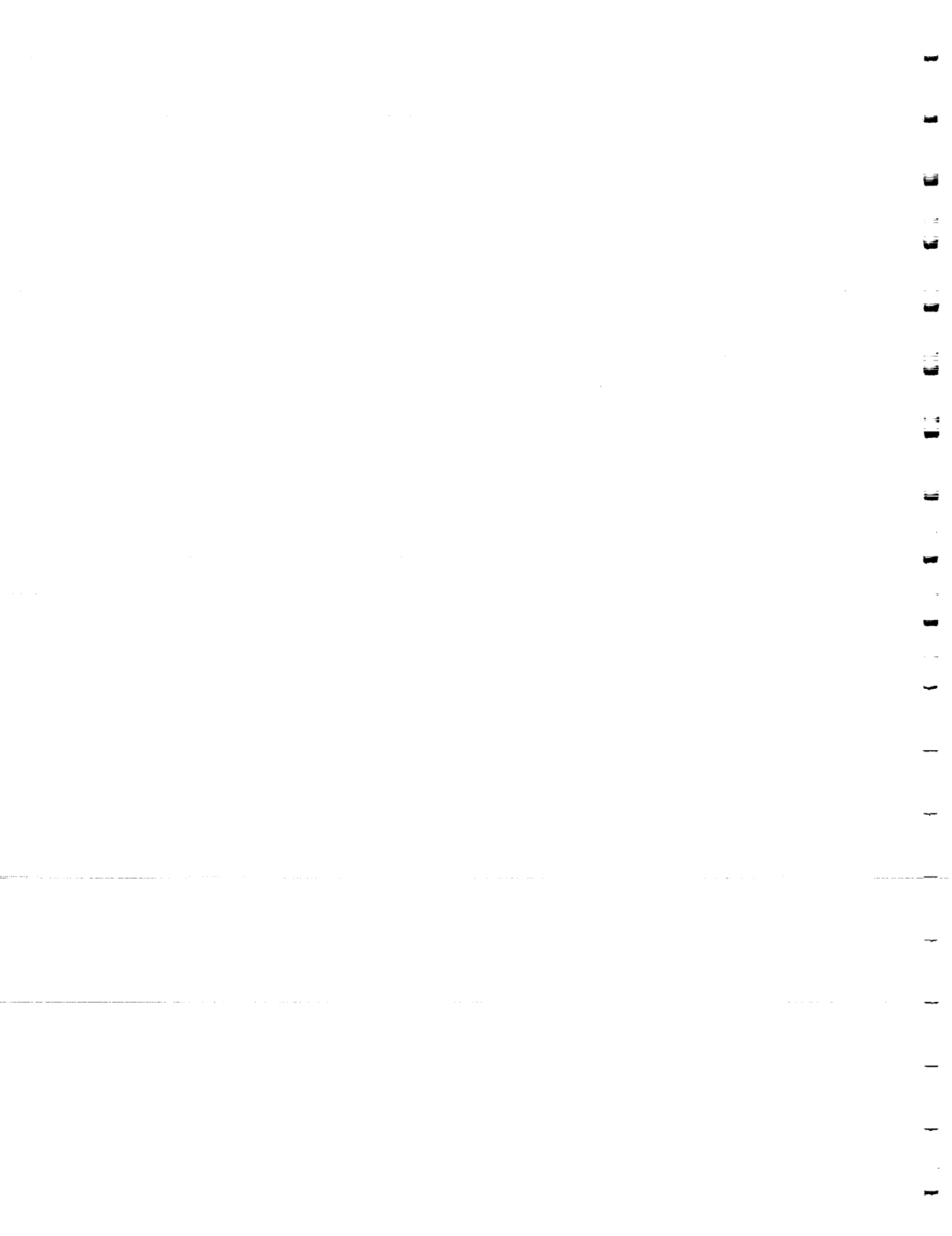

## 1996 SEMINAR SERIES

June 7th

“Professional Responsibility and Solving Ethical Problems”

**Michael J. Rabins, Professor**

Department of Mechanical Engineering  
Director, Engineering Ethics and Professionalism Program  
The Texas A & M University System

June 14th

“Laboratory Experiments in a Weightless Environment:  
Why Do We Go There and What Do We Get?”

**Joseph M. Prahl, Professor and Chair**

Department of Mechanical & Aerospace Engineering  
Case Western Reserve University, Cleveland, Ohio

June 21st

“Light Scattering in Space: NASA Lewis Challenges in  
Extending the Frontiers of Condensed Matter Physics”

**Anthony E. Smart, Professor**

NASA Space Station Group at NASA Lewis, Consultant  
NASA Lewis Research Center, Cleveland, Ohio

June 28th

“ACTS’ Legacy: The Ka-Band Explosion”

**Ronald J. Schertler, Chief**

ACTS Experiments Office  
NASA Lewis Research Center, Cleveland, Ohio

July 12th

“Recent Discoveries from the Hubble Space Telescope”

**Ray Villard, News & Information Manager**

Space Telescope Science Institute  
Johns Hopkins University, Baltimore, Maryland

July 19th

“Materials Science in Space”

**Thomas K. Glasgow, Chief**

Processing Science and Technology Branch  
NASA Lewis Research Center, Cleveland, Ohio

July 26th  
"Preparing Engineers for Practice in the 21st Century"  
**Thomas P. Kicher, Dean**  
The Case School of Engineering  
Case Western Reserve University, Cleveland, Ohio

August 2nd  
"NASA's Map Mission Looks at the Origin of the Universe"  
**David T. Wilkinson, Professor**  
Cyrus Fogg Brackett Professor of Physics  
Princeton University, Princeton New Jersey

## APPENDIX B

### SUMMARY OF PARTICIPANTS' RESEARCH

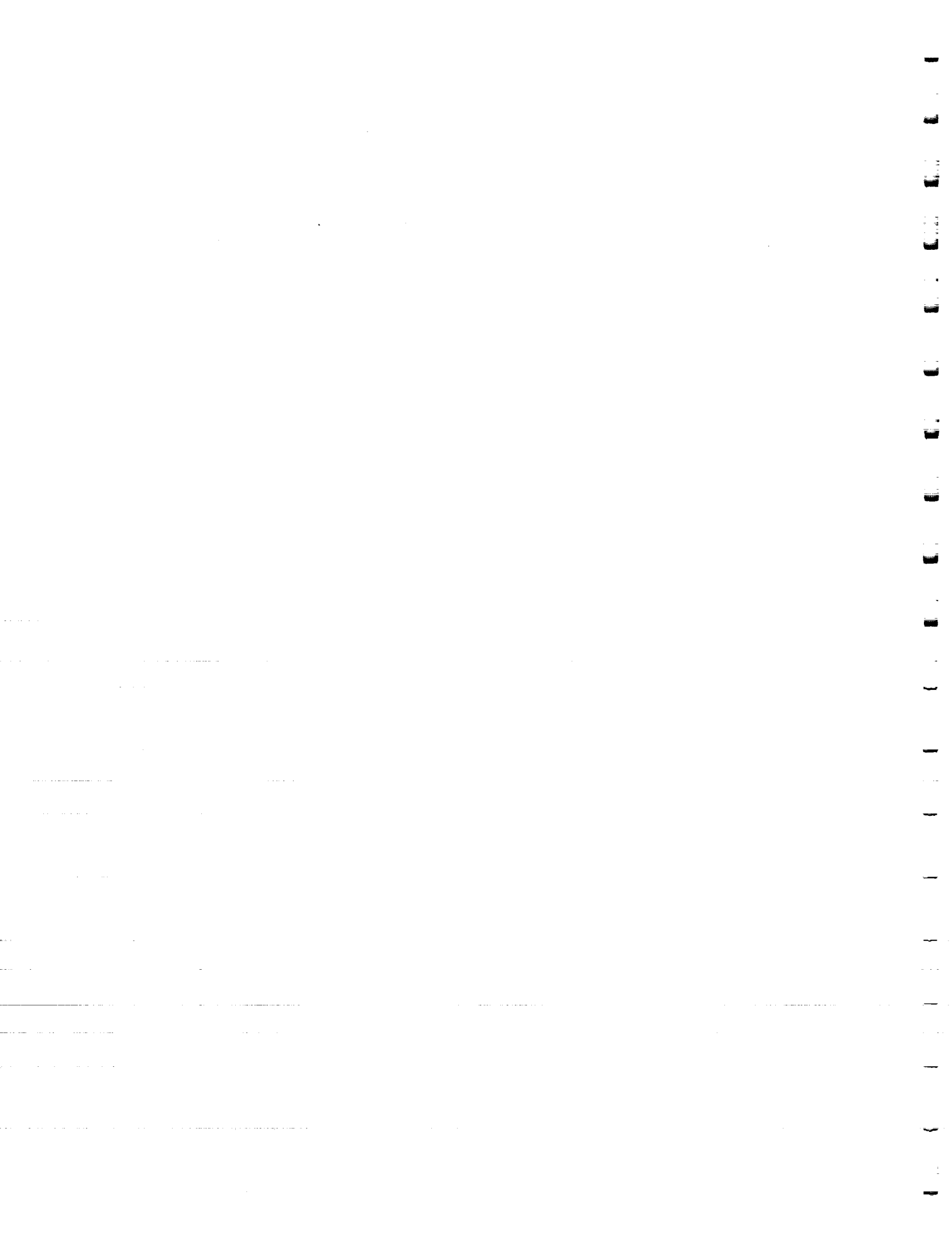



Name: Om P. Agrawal  
Education: Ph.D., Mechanical Engineering  
University of Illinois at Chicago

Permanent Position: Associate Professor, Mechanical Engineering  
Southern Illinois University

Host Organization: Structures Division  
Colleague: Shantaram S. Pai

Assignment:

This research will develop a wavelet based approach to obtain the probabilistic characteristics of structural systems. In this approach, the correlation functions describing the stochastic variations in the material and geometric properties of the system will be represented as a sum of eigenfunctions with uncorrelated random coefficients. The integral eigenvalue problems associated with the stochastic processes will be solved using wavelet bases, which will also be used to generate various stochastic matrices. A numerical technique based on the Neumann expansion will be developed to compute probabilistic characteristics for the displacements and the stresses in the structures. A set of selected problems will be solved to demonstrate the effectiveness of the approach. Whenever possible, general purpose subroutines will be developed for use with other existing programs. Feasibility of coupling the resulting code to an existing computer code at NASA will be examined, and depending upon the architecture of the code at NASA, the coupling of the two codes will be performed either during or after the fellowship period.

---

### **Wavelet Based Model for Stochastic Analysis of Structures**

The major accomplishments for this summer are as follows:

1. Developed efficient numerical techniques for 1- and 2-dimensional wavelet transform of functions and for the solution of integral eigenvalue problems associated with random processes. Validated the techniques by solving two examples and comparing the results obtained using these techniques with those obtained using analytical techniques.
2. Developed wavelet based model for stochastic analysis of structures. Validated the model by solving four examples and comparing the results obtained using this model with those obtained using semi-analytical and numerical techniques.

Papers describing the above techniques and the results have been submitted to two journals for publication.

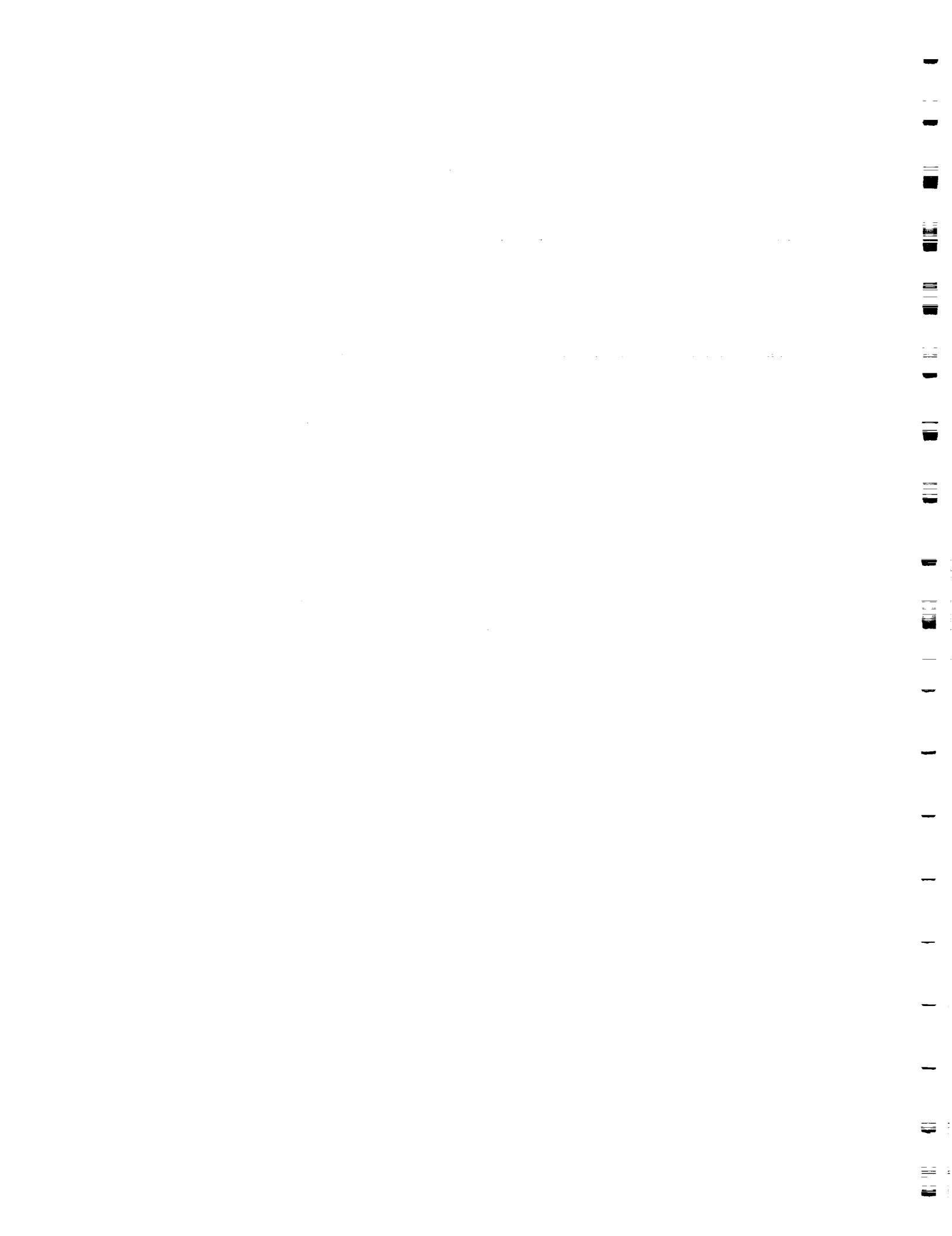

Name: Steven J. Bever  
Education: Ph.D., Electrical Engineering  
Purdue University

Permanent Position: Associate Professor, Physics  
Wabash College

Host Organization: Instrumentation and Control Technology Division  
Colleague: Robert C. Anderson

Assignment:

Measurement of liquid droplet size and velocity in clouds using the Phase Doppler Particle Analyzer (PDPA) is of interest in aircraft icing research and in combustion research where fuel injector spray characterization is required. A new technique for verifying the operation and calibration of the PDPA has been developed. The new method consists of placing a microlens in the sensing volume of the instrument thus simulating a water-droplet. The objective of this research effort is to evaluate both theoretically and experimentally the efficacy of the technique using microlenses. Specifically, the research involves characterizing microlenses physically using a profilometer, measurement of light scattering from microlenses, preparing a theoretical model of the instrument response to the microlenses, and comparing the theoretical instrument response with the actual response.

### **Evaluation of Microlenses for Calibration of the Phase Doppler Particle Analyzer**

Measurement of liquid droplet size and velocity in clouds using the Phase Doppler Particle Analyzer (PDPA) is of interest in aircraft icing research. In addition, the PDPA is used in combustion research where fuel injector spray characterization is required. A new technique for verifying the operation of the PDPA has been developed. The new method consists of aligning a microlens in the sensing volume of the PDPA. Since the scattered light from a microlens is similar to that from a water droplet, the PDPA registers the presence of a water droplet and measures the characteristics of the microlens in the sensing volume.

The microlenses investigated this summer were polymer plano-convex lenses attached to optical flats. The diameter of the microlenses was  $60.3 \mu\text{m}$  and the thickness of the microlenses was  $10.6 \mu\text{m}$ . A numerical simulation of the scattered field for a microlens in the probe volume of the PDPA was developed. The simulation traces rays from the flat surface of the lens to the plane which is tangent to the lens and contains the second vertex. The farfield intensity pattern is determined by numerically evaluating Kirchoff's integral for the field resulting from the raytracing procedure.

Tests with two PDPAs and three microlenses of the same diameter and thickness are summarized in Table 1. Since we wished to test for effects of deviations in curvature of the microlenses, each lens was rotated in increments of  $45^\circ$  while in the probe volume of each PDPA. Certain orientations of the lenses produced smaller ranges of readings than others. Since  $2 \mu\text{m}$  corresponded to the resolution limit of the instrument, the variation in readings for four of the positions were acceptable.

A new technique for verifying the operation of the PDPA has been developed. The new method consists of aligning a microlens in the sensing volume of the PDPA. Based on experimental results, we conclude that microlenses are viable calibration reticles for the PDPA.

**Table 1. Summary of experimental results using three microlens calibration reticles with two PDPAs.**

<b>Rotational Orientation (Degrees)</b>	<b>Range of PDP A Results</b>
0	$75 \pm 2$
45	$76 \pm 2$
90	$73 \pm 4$
135	$73 \pm 4$
180	$72 \pm 2$
225	$73 \pm 2$
270	$74 \pm 3$
315	$75 \pm 3$

Name: Darwin L. Boyd  
Education: Ph.D., Physics  
Kent State University

Permanent Position: Part-time Instructor, School of Technology  
Kent State University

Host Organization: Materials Division  
Colleague: Jeffrey I. Eldridge

Assignment:

New experimental methods will be applied to investigating the response of the fiber/matrix interface to stresses developed within fiber-reinforced composite materials. The crackdeflecting ability of the fiber/matrix interface will be investigated by monitoring crack propagation during a 4-point flexure test. In particular, the behavior of a matrix crack approaching the fiber/matrix will be examined. The tensile strength of the interface will also be evaluated by transverse compression and 4-point flexure tests. The results will be analyzed to aid in the selection of appropriate fiber coatings to provide optimum composite performance.

---

### **Experimental Investigation of the Fiber/Matrix Interface in FiberReinforced Composites**

I used several methods to experimentally investigate the fiber/matrix interface in metal matrix and ceramic matrix composites. These methods included transverse compression tests, push-out flexure tests, displacement flexure tests, and crack-deflection flexure tests. Results of the displacement flexure and the crack-deflection flexure tests were particularly interesting.

#### **Displacement Flexure Test**

The displacement flexure test utilized a recently observed phenomenon in metal matrix composites. Namely, tensile stresses that occur when metal matrix composite samples are tested in a bending configuration tend to debond the fibers. The fibers then elongate relative to the matrix in order to relieve residual stresses.

I tested metal matrix composites in a four point bend geometry. This testing geometry subjects the bottom of the sample to tension and the top to compression. The neutral plane in the center of the sample is subjected to neither tension nor compression.

As might be expected, the tests revealed increasing fiber elongation toward the bottom of the sample where the tensile stress is greatest. At low loads the fiber elongation increased with increasing number of cycles up to 10 cycles but showed no further increase between 10 and 100 cycles. At high loads the samples exhibited much greater elongation with the elongation again increasing toward the bottom of the samples. This time the fibers continued to elongate with increasing number of cycles even past 100 cycles but the elongation seemed to be approaching a limit near 200 cycles. Tests at increasing loads showed increasing fiber elongation.

Two important composite parameters can potentially be derived from these results. The first is fiber bond strength. The strength of the bond between the fiber and the matrix is very important to composite behavior. Second, this experiment provides a method of measuring the residual stresses in these materials. Simplistic calculations indicate that the maximum elongation seen during these tests approaches the maximum expected if the fibers completely debonded and relieved all residual stress.

## Crack-Deflection Flexure Test

The crack-deflection flexure test, though not very quantitative, can provide striking confirmation or refutation of assumed composite behavior. I used this test on several brittle ceramic or glass matrix composites.

The samples for this test were similar to that for the displacement flexure tests except the fiber direction was along the long axis of the sample. Each sample had a notch cut across the bottom to initiate the crack. Again the testing geometry was a four point bend configuration with the sample viewed from the side with the video microscope.

Results varied widely between the different materials tested. Some samples failed in a brittle manner with no crack deflection at the fiber matrix interfaces. Other materials showed much better composite type behavior with the cracks deflecting and branching at the interfaces. The best composite behavior was seen with a sample that had relatively small SiC fibers with a BN coating in a BSAS matrix.

Name: Martin Cala  
Education: Ph.D., Industrial Engineering  
State University of New York at Binghamton

Permanent Position: Assistant Professor, Industrial and Systems Engineering  
Youngstown State University

Host Organization: Workgroup Hardware and Software Lead Center Office  
Colleague: Steven M. Sidik

Assignment:

To conduct an analysis of NASA-wide standards for computer aided engineering, design, and manufacturing software tools. In particular, investigate applicability of the software capability maturity model related to testing and product selection in support of the NASA Workgroup Hardware and Software Lead Center Office.

---

### **Selection Criteria Modeling for CAE/D/M Software**

#### **PURPOSE:**

To develop a framework for decision-making processes within the scope of the Workgroup Hardware/Software (WHS) Lead Center (LC). To demonstrate possible decision-making behaviors based upon representative inputs. To identify possible problem-solving intermediate "values" and final outputs. To compliment the stated goals and objectives of the WHS LC with a template for integration into an Agency-wide network. And, ultimately, to identify the CAE/D/M hardware/ software performance measures that support meaningful decision-making behaviors. To determine rate of phase-out on CADAM and phase-in of future products by Center and work-mix areas within Centers.

#### **SCOPE:**

The project to develop a Management Information Module with the purpose indicated shall be limited to the CAE/D/M domain. The CAE/D/M domain will be considered all those objectives, resources, and issues related to the definition of the Expert Center-CAE/D/M. Relevant inputs for the purpose of developing the prototype module as described will be limited to four main areas:

1. Project Requirements
2. Product Specifications
3. Agency Installations Status
4. WHS Lead Center Goals and Objectives

This definition of scope is intended to serve a viable module validation process while demonstrating problem solving behaviors using relatively ill-defined, and a relatively large number of inputs.

### **VIRTUAL ENVIRONMENT**

#### **I. PROJECT REQUIREMENTS**

Project requirements for CAE/D/M hardware and software may be to serve the needs of no less than three distinct parties:

1. Operators/Designers
2. Engineers/Developers
3. Project and Line Managers

Requirements may include feature availability/usability at one extreme or interoperability/cost effectiveness at the other extreme. Ultimately, project requirements will be chosen for the prototype module that will represent the spectrum of possible inputs. The prototype inputs representing project requirements shall be input through a user interface by query sessions or by file transfer, and these inputs shall reside collectively as the requirements node. The requirements node shall be input to a "Planning Module".

## II. PROJECT SPECIFICATIONS

Project specifications for hardware and software shall be input by query or by file transfer to the product node. This node shall represent any relevant CAE/D/M hardware or software products, their capabilities, and performance measures, if known. These will be COTS offerings.

## III. INSTALLATIONS NODE

Limiting the definition of the installed base for Agency-wide CAE/D/M to commercial-off-the-shelf (COTS) applications, a relevant set of products now in use will be input to the installation node. The installation node shall be enhanced and augmented with relevant features of the inuse products. The installation node shall be input to the analysis module.

## IV. MANAGEMENT INTERFACE CONSOLE

The Management Interface Console has the dual purpose of allowing input of WHS-LC objectives together with pertinent session criteria, constraints, and other session specific parameters. From this node in the virtual environment all other interface activities will be directed and monitored; sessions will be initiated, monitored, and facilitated, when necessary to closure; no reports will be specified and generated. Output from this will be used as input to the control module.

## **PROBLEM SOLVING MODULES**

### I. PLANNING MODULE

The Planning Module receives input from the requirements and products nodes. According to pre-selected specifications issued from the Management Interface Console, these inputs are processed (filtered) to establish a broad, relatively unrestricted plan for CAE/D/M Hardware/Software acquisitions. This stage of planning in the hierarchical decision process is dependent on requirements and availabilities under assumed performance levels, and without recognition of the economy of the installed base. It's output is input to the analysis module. It's output is a planning list.

### II. ANALYSIS MODULE

The Analysis Module receives the unrestricted output of the Planning Module together with the descriptive information representing the installed base. These inputs are processed according to the pre-selected criteria set through the Management Console. This analysis stage in the hierarchical decision making process is carried out under presumed performance levels with recognition, however, of the economy of the installed base. Analysis Module output is a detailed rational list.

### III. CONTROL MODULE

The Control Module receives the limited output of the analysis module together with the session specific criteria from the management interface console to arrive at a control strategy with expected performance measurement parameters. Depending on the specifics of a session these parameters may take various forms. In general, measures of performance will be provided for hardware effectiveness, software capability maturity, and interoperability performance. Custom indexes of any or all performance measures would be desirable for generating performance overtime types of reports (line graphs).



# CAE/D/M STRATEGIC MANAGEMENT MODULE

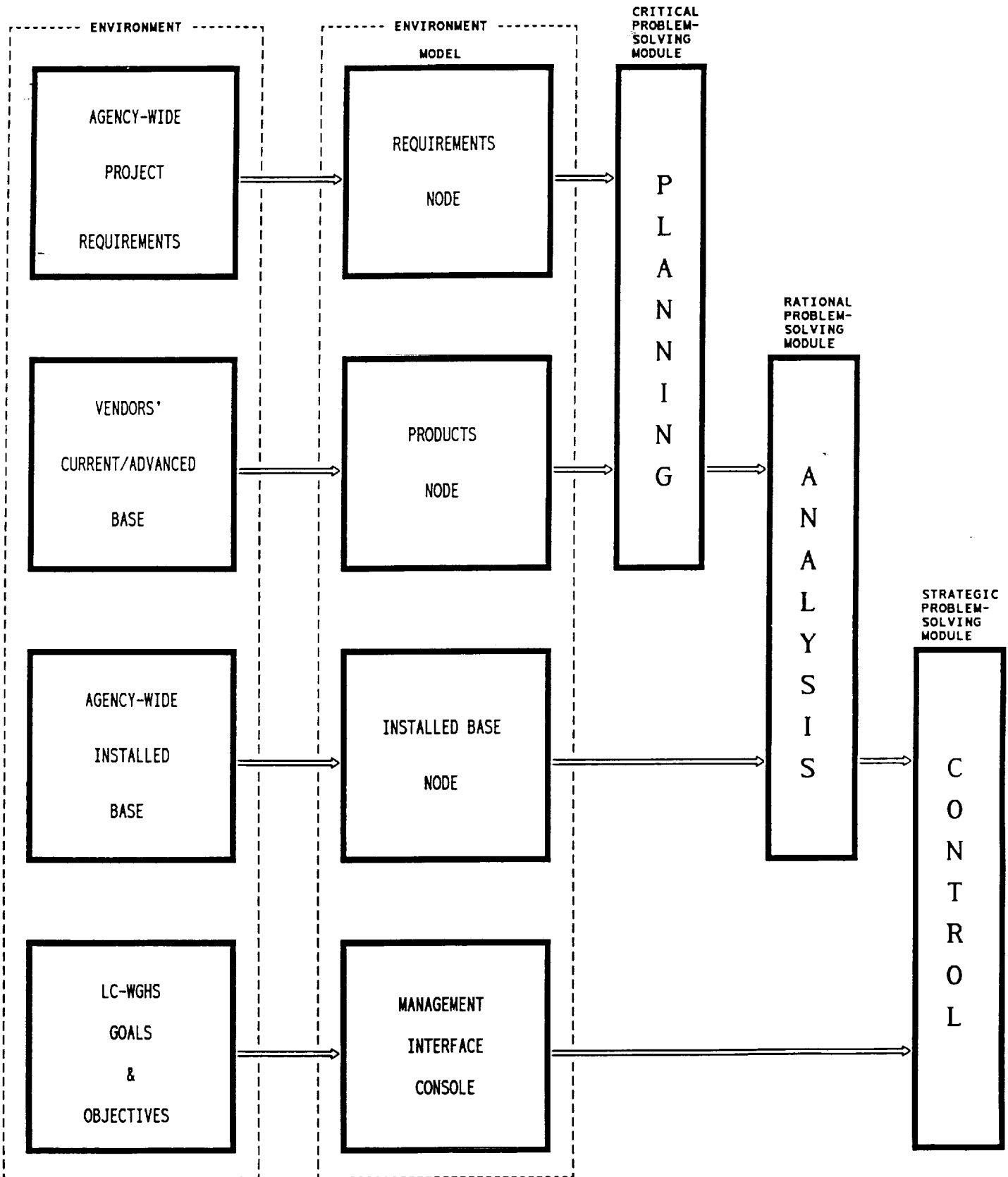

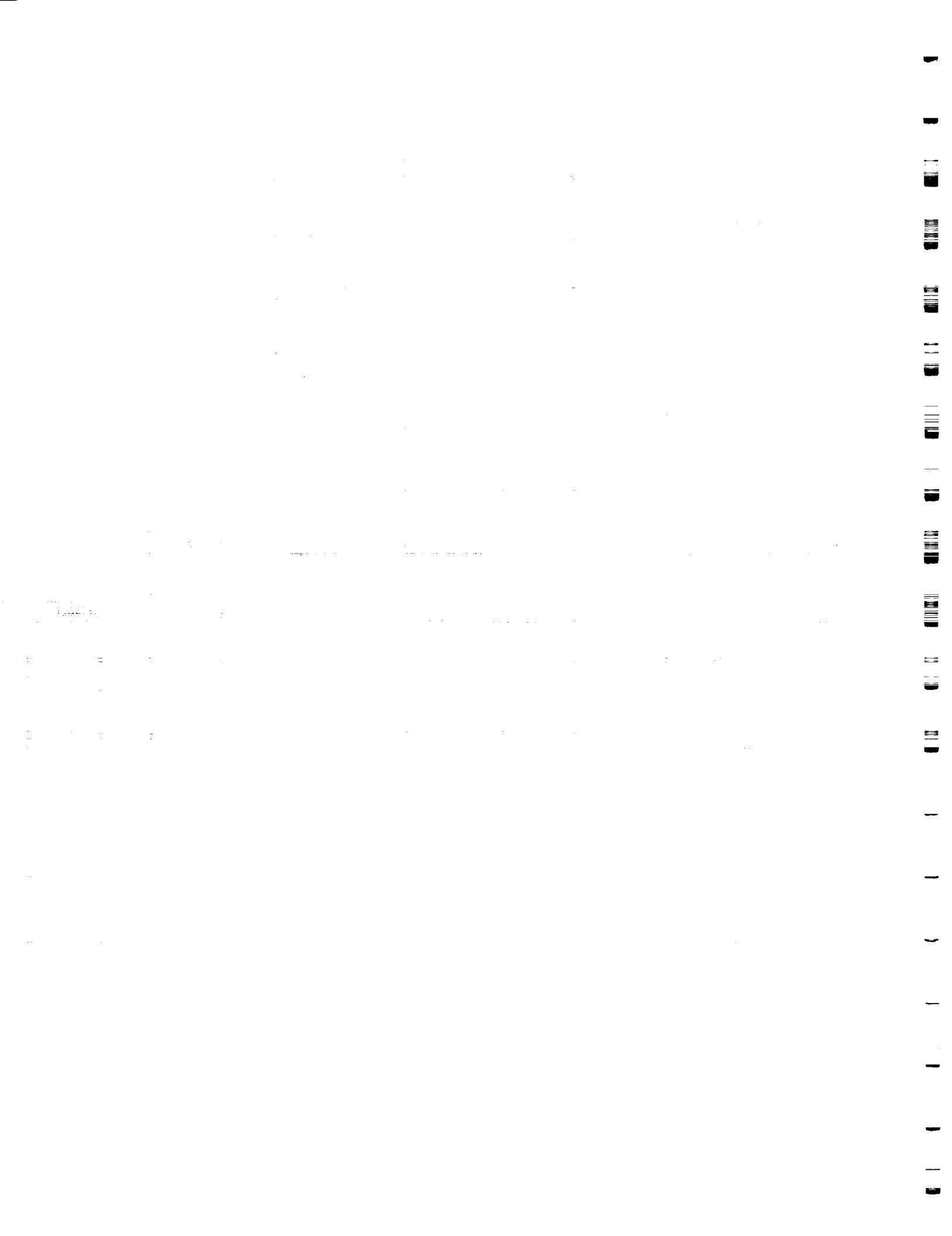

Name: H. Michael Cheung  
Education: Ph.D., Chemical Engineering  
Case Western Reserve University

Permanent Position: Associate Professor, Chemical Engineering  
University of Akron

Host Organization: Materials Division  
Colleague: Thomas K. Glasgow

Assignment:

The area of research to be involved in is the development, both hardware and software, and proof of principal demonstration of a compact, fiber optic interferometer. This would have considerable potential for application in microgravity materials study, especially for interfaces.

---

### **Development of Laser Vibrometry Hardware and Software**

During my summer faculty fellowship this year I was mainly concerned with the development of laser vibrometry tools, both hardware and software. The hardware effort was targeted at the development of a fiber optic based laser vibrometer. This instrument has potential applications in a number of experiments of interest to the division. After screening several optical designs a Mach-Zender interferometer was settled upon for the initial implementation. This instrument has been designed and the fiber optic components obtained. Final construction and testing will be conducted shortly. As presently envisioned, this instrument will represent not only a fiber implementation of the current state of the art, but also a platform for improving upon the state of the art via the use of advanced signal detection and multiple laser lines. I will remain involved as part of continuing collaboration between myself and the division.

The software effort was part of a continuing effort to develop in house Windows 95 software capabilities for support of optical hardware developed in the division. I served mainly as a resource to that effort. As a researcher with experience with this type of instrumentation, I provided feedback to the programmers on the capabilities required and the "look and feel" of the user interface. My programming skills were also tapped in the hardware interfacing and debugging phases of the software project.

Another effort I also served as a resource for was the protein crystal growth project. Specifically I contributed to the preliminary design of a second generation experiment for studying the surface tension of protein crystal growth media during crystallization.

1. The first part of the document discusses the importance of maintaining accurate records of all transactions.

2. It then goes on to describe the various methods used to collect and analyze data.

3. The next section details the results of the study and the conclusions drawn from the data.

4. Finally, the document provides a summary of the findings and offers suggestions for future research.

5. The following table shows the distribution of data across different categories.

6. The data indicates that there is a significant correlation between the variables studied.

7. This suggests that the factors being investigated are closely related to each other.

8. The results of the study are consistent with previous research in this field.

9. However, there are some limitations to the study that should be noted.

10. These limitations include the sample size and the potential for bias in the data collection process.

11. Despite these limitations, the study provides valuable insights into the relationship between the variables.

12. The findings have important implications for the field and should be taken into account in future studies.

13. In conclusion, the study has shown that there is a strong link between the variables being examined.

14. This relationship is supported by the data and is consistent with theoretical expectations.

15. The study also highlights the need for further research to explore the underlying mechanisms of this relationship.

16. Overall, the research contributes to the understanding of the complex interactions between the variables.

17. The results are presented in the following table, which shows the distribution of data across different categories.

18. The data indicates that there is a significant correlation between the variables studied.

19. This suggests that the factors being investigated are closely related to each other.

20. The results of the study are consistent with previous research in this field.

Name: Mun Young Choi  
Education: Ph.D., Mechanical and Aerospace Engineering  
Princeton University

Permanent Position: Assistant Professor, Mechanical Engineering  
University of Illinois at Chicago

Host Organization: Space Experiments Division  
Colleague: DeVon W. Griffin

Assignment:

For the summer of 1996, Professor Choi's assignments will be: (1) Study the effects of morphology on the signal intensity in LII. (2) Study the effects of primary soot particle size on the decay of LII signals. (3) Study the effect of laser heating on soot structure. Accompanying student: Kirk A. Jensen.

---

## Measurement of Soot Using Laser-Induced Incandescence [LII].

### Introduction

Major accomplishments during my third summer appointment at NASA-Lewis included completing projects related to measurement of soot using laser-induced incandescence [LII]. The experiments were performed in collaboration with Dr. Randall Vander Wal in his optical diagnostics laboratory.

LII has emerged as a viable non-intrusive technique for measuring soot concentrations in flames. Incandescence of soot occurs when laser light heats the particles to the incandescent temperature (which is typically ~ 4000 K). It has been predicted that the resulting radiant emission intensity is proportional to the soot concentration. Vander Wal, Zhou and Choi [1996] compared the LII intensities to gravimetrically-measured soot concentrations and found good correspondence (which was used to determine the calibration factor). Although, a recent investigation by Vander Wal, Choi and Lee [1995] indicated a significant change in the morphology of the soot as a result of the rapid heating by the laser, a new study suggests that the LII intensity (and therefore the soot volume fraction deduced from the emission) are not affected [Vander Wal and Choi, 1996].

### LII Correction Technique

There are many practical benefits for using LII for soot concentration measurements. This technique is more accurate than the conventional light extinction method since it is expected to be less sensitive to light scattering by soot particles and absorption by large PAH molecules. In previous applications of LII for both laminar droplet and gaseous diffusion flames, calibrations of the incandescence signal were compared to light extinction measurements of soot volume fractions at specific locations (either point or limited spatial regions) within the sooting region of the flame. In this traditional method of calibration, inherent assumptions were made that the level of attenuation through the soot layer separating the incandescing soot particles and the detection optics was negligible. Therefore, the measured intensity distribution (attenuated) was deemed proportional to the radial distribution of the soot concentrations. Serious discrepancies between actual and calibrated soot distributions can exist for conditions producing sootier conditions or for larger extent of the sooting region. Furthermore, traditional calibration techniques require multiple line of sight light extinction measurements and subsequent tomographic inversions to determine the soot concentrations at various locations within the flame. Thus, the motivation was to develop an alternative technique for soot concentrations for axisymmetric flames using the projected (attenuated) intensity distributions. The unique aspect

of this technique is that only a single line of sight light extinction measurement is required for calibration of LII. The predicted soot concentrations using the projected intensities and a single line light extinction calculated using the hypothetical soot distribution) provided excellent agreement with the hypothetical soot distribution. [This work is in review for publication in *Combustion and Flame*].

### Effects of Laser Heating On Soot

Experiments and analysis were also performed to determine the effects of laser heating on soot particles. In these experiments, soot particles captured on sampling grids were analyzed (using transmission electron microscopy technique) before and after being ablated to determine the degree of vaporization and mass loss.

I've gained valuable experience by being able to work with Dr. Vander Wal and other members of the SED diagnostics group. My accompanying summer student, Kirk Jensen, has also benefitted from the extensive involvement in the laboratory and through enlightening discussions related to research. His involvement in the accompanying student program was instrumental in identifying the important topics for his successful proposal for the **NASA Graduate Researcher Fellowship**. He will continue to work closely with Dr. Vander Wal on topics of mutual interests including LII and Wavelength Modulation Spectroscopy.

### Journal Publications Related to Work Performed During Appointment as NASA-ASEE Fellow

1. Vander Wal, R.L., Zhou, Z. and Choi, M.Y., "Spatially-Resolved Spectral and Temporal Characterization and Gravimetric Sampling Calibration of Laser-Induced Incandescence", *Combustion and Flame*, 105:462- 470 (1996).
2. Vander Wal, R.L., Choi, M.Y. and Lee, K.O., *Combust. Flame*, 102:200-204 (1995).
3. Vander Wal, R.L. and Choi, M.Y., "Pulsed Laser Heating of Soot: Morphological Changes", submitted to *Applied Optics*, (1996).
4. Vander Wal, R.L., Jensen, K.A. and Choi, K.A., "Simultaneous Laser-Induced Emission of Soot and Polycyclic Aromatic Hydrocarbons Within a Gas-Jet Diffusion Flame", accepted for publication in *Combustion and Flame*, 1996.
5. Choi, M.Y. and Jensen, K.A., "Some Further Considerations for the Calibration of Laser Induced Incandescence for Soot Volume Fraction Measurements", *Combustion and Flame*, in review, 1996.

Name: Kirk A. Jensen  
Education: University of Illinois at Chicago

Permanent Position: Student  
University of Illinois at Chicago

Host Organization: Space Experiments Division  
Colleague: DeVon W. Griffin

Assignment:

Accompanying student under the direction of Professor Mun Young Choi.

---

### **Introduction**

During my appointment at NASA, we accomplished several tasks that were beneficial to both my NASA colleague and progress toward the completion of my Ph.D. We performed numerous experiment that lead toward a better characterization of the Laser Induced Incandescence (LII) measurement technique for measuring the soot concentration in flames. Several of our experiments focused on using two laser pulses to measure the soot concentrations in a flame, and by comparing measurements from each pulse we were able to show how the laser does, in fact, alter the soot. Several of our experiments were aimed at verifying the results of our work last summer at LeRC using the two-pulse set up.

In addition to experiments involving the measurement of soot concentration with the LII method, we also performed numerous "sampling" experiments and Transmission Electron Micrograph (TEM) analyses to actually see how the soot morphology is altered by the LII measurement. As a result of our TEM and LII experiments performed this summer, we are submitting a paper to the Combustion Institute for presentation this Fall.

We also managed to perform experiments that involve the laser induced incandescence technique and simultaneous light extinction measurements. These results are being used to verify a new calibration technique proposed by my thesis advisor, Dr. Mun Y. Choi from the University of Illinois at Chicago.

As an Accompanying Student, the ASEE program has greatly accelerated my progress as not only a Ph.D. student, but also as a researcher. Dr. Vander Wal is a remarkable scientist and the experience of working with him through this program has taught me many important skills that I will use in the future. In addition, the program has provided the opportunity for me to become acquainted with other microgravity researchers and programs at LeRC.

1. The first part of the document discusses the importance of maintaining accurate records of all transactions. This is essential for ensuring the integrity of the financial data and for facilitating the audit process. It is recommended that all transactions be recorded in a timely and accurate manner, and that the records be kept for a sufficient period of time to allow for a complete audit.

2. The second part of the document discusses the importance of maintaining accurate records of all assets and liabilities. This is essential for ensuring the accuracy of the financial statements and for facilitating the audit process. It is recommended that all assets and liabilities be recorded in a timely and accurate manner, and that the records be kept for a sufficient period of time to allow for a complete audit.

3. The third part of the document discusses the importance of maintaining accurate records of all income and expenses. This is essential for ensuring the accuracy of the financial statements and for facilitating the audit process. It is recommended that all income and expenses be recorded in a timely and accurate manner, and that the records be kept for a sufficient period of time to allow for a complete audit.

4. The fourth part of the document discusses the importance of maintaining accurate records of all tax payments and deductions. This is essential for ensuring the accuracy of the financial statements and for facilitating the audit process. It is recommended that all tax payments and deductions be recorded in a timely and accurate manner, and that the records be kept for a sufficient period of time to allow for a complete audit.

5. The fifth part of the document discusses the importance of maintaining accurate records of all bank statements and other financial documents. This is essential for ensuring the accuracy of the financial statements and for facilitating the audit process. It is recommended that all bank statements and other financial documents be recorded in a timely and accurate manner, and that the records be kept for a sufficient period of time to allow for a complete audit.

6. The sixth part of the document discusses the importance of maintaining accurate records of all other financial information. This is essential for ensuring the accuracy of the financial statements and for facilitating the audit process. It is recommended that all other financial information be recorded in a timely and accurate manner, and that the records be kept for a sufficient period of time to allow for a complete audit.



Name: Krzysztof J. Cios  
Education: Ph.D., Computer Science  
AGH Technical University, Poland

Permanent Position: Associate Professor, Electrical Engineering and Computer Science  
University of Toledo

Host Organization: Structures Division  
Colleague: George Y. Baaklini

Assignment:

Professor Cios is expected to assist at Lewis Research Center (LeRC) in the neural network/acoustic emission analysis of impact damaged kevlar/epoxy and/or graphite/epoxy pressure vessels. This work will also help ongoing efforts between Marshall Space Flight Center and LeRC in studying NDE of impact damage of pressure vessels. In specific, Professor Cios will be applying multiparametric acoustic emission (AE) study where radial basis functions and fuzzy logic networks can be applied and compared. Methods for quantitatively proof testing impact damage composite pressure vessels at subcritical loads via neural network analysis of AE parameters distribution data will be established. This study will reduce in-service problems that plague composite industries in general.

---

### **Neuro-Fuzzy Analysis of Impact Damaged Graphite/Epoxy Pressure Vessels**

The goal of the project was to analyze the acoustic emission data collected on impact damage, inert propellant filled, filament wound pressure vessels, and possibly correlate it with burst pressure. The data was made available to us by Marshall Space Flight Center, and consisted of 11 and 9 files corresponding to unfilled and filled kevlar/epoxy vessels, respectively. Five parameters were measured: amplitude, energy, duration, risetime, and pressure, measured on four channels.

The preprocessing was done by thresholding the amplitude under 60dB and taking the data from the first pressurization ramp and hold through 800 psig. Two neural network types were used for analysis, radial basis functions (RBF) and backpropagation (BP), and a fuzzy logic system. The input to the networks was the distribution of amplitudes obtained as a histogram over the range from 60 to 100 dB. The output was the burst pressure.

For the fuzzy system because of high dimensionality (41 for one channel) of the input, the antecedent part of the fuzzy rules was obtained by fuzzy-classifying the testing data points among the training data classes. The fuzzy output was formed from fuzzy sets with peak values at the burst pressure of the training set. To obtain crisp values of the burst pressure first the minmax inference of the rules and centroid method of defuzzification were used. The results, from using all four channels, and just one channel, show that a reliable prediction cannot be made of the burst pressure of the bottles studied, since the individual errors of prediction could be very large (and thus calculating average error does not make sense).

Possibly one way of improving the results of prediction would be to consider collecting a large (around 1000) number of amplitude measurements at 800 psig (this would give a better approximation of the distribution) and to increase the number of bottles.

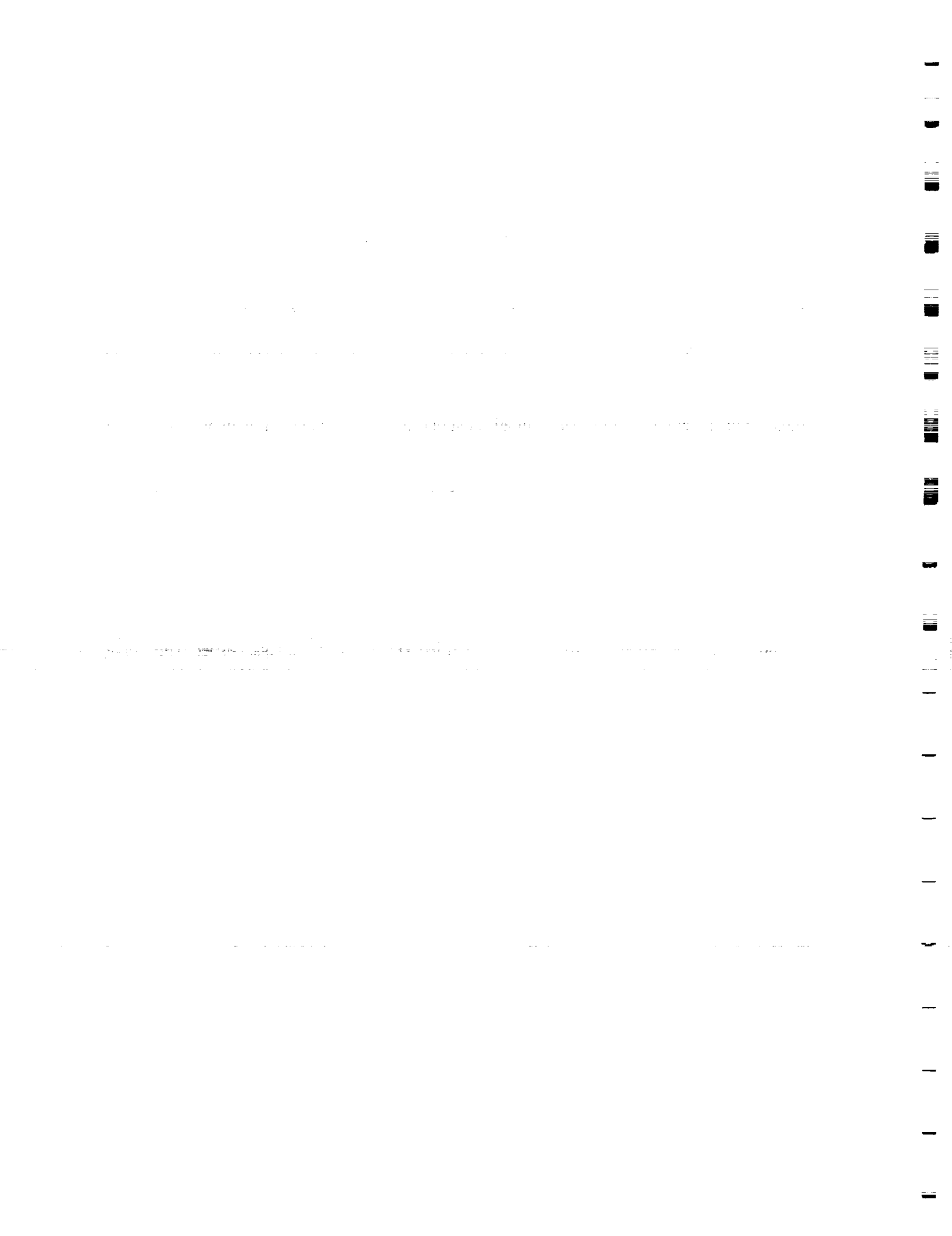

Name: David L. Crane  
Education: Ph.D., Mechanical Engineering  
Texas A&M University

Permanent Position: Assistant Professor, Mechanical Engineering  
University of Texas at San Antonio

Host Organization: Structures Division  
Colleague: Steven M. Arnold

Assignment:

Dr. Crane will be participating in the implementation of a coupled deformation and continuum damage mechanics algorithm (for fatigue of unidirectional MMCs) into the finite element code ABAQUS. Applications of this algorithm to a 35% circumferentially reinforced volume fraction SCS-6Ti-6-4 TMC ring insert will be made. Results will directly impact ongoing experimental and analytical work being conducted within our MMC Life Prediction Consortium.

---

### **Deformation/Damage Approach to Fatigue in Gas Turbin/Compressor Disks**

The NASA-ASEE faculty fellow program has presented the opportunity to participate in state-of-the-art research. The Summer of '96 is the second time I (David Crane) have had an extended visit at NASA Lewis Research Center and have had an opportunity to work with Dr. Steve Arnold in the Structures group. My first visit was during the Summer of '95 when I was associated with a NASA IRA grant awarded to The University of Texas at San Antonio. As a result of administrative problems and uncertainties with the grant, I was encouraged to apply and was accepted for the NASA-ASEE program.

During the two Summer visits to NASA Lewis, I have had the opportunity to focus my attention on a combined deformation/damage approach to fatigue in gas turbin/compressor disks. The ultimate goal of the project is to be able to predict the extent of life in transversely isotropic engine components taking into account the effects of load redistribution resulting from cycle dependent damage. As a first attempt, the damage was considered to be a scalar internal state variable. Dr. Arnold previously spent a sabbatical in France formulating this approach for transversely isotropic materials. The evolution law for the scalar damage parameter is a first order nonlinear ordinary differential equation. The increment of damage with respect to number of fatigue cycles is related to the normalized stress amplitude, static fracture surface, and the fatigue limit surface. The damage parameter is updated after each complete fatigue cycle.

In order to make this versatile, the theory was coded in an user subroutine for the commercial finite element packages MARC and ABAQUS. A majority of the subroutine development for MARC was completed prior to the Summer of '95. During my first Summer visit 90% of the subroutine for ABAQUS was completed and verified. A continuation of the work in the Summer of '96 included the use of the newly developed program to analyze a SiC circumferentially reinforced titanium metal matrix rotating disk. This Summers work some of which to be completed upon return to The University of Texas at San Antonio involves a study comparing fatigue lives of disks subjected to a wide range of angular frequencies. Several configurations will be compared including an internally pressurized disk, an angularly rotating disk, an angularly rotating disk with the effect of blades smeared uniformly around the outside circumference, and a 2.94% portion of a 3-D disk containing a discrete blade. Except for the 3D work, the majority of the computer runs for this project were completed during my stay at NASA Lewis this Summer.

NASA is currently involved in testing several SiC reinforced titanium metal matrix disks for ultimate properties as well as fatigue behavior. As a side project, I embarked on determining the limiting angular frequency for these disks based on plastic overload combined with the ultimate strain in the SiC fibers. The experimental work currently being completed will provide a valuable verification of the theoretical methodologies.

Name: Richard P. Donovan  
Education: Ph.D., Mechanical Engineering  
University of Wyoming

Permanent Position: Assistant Professor, Mechanical and Civil Engineering  
University of Evansville

Host Organization: Structures Division  
Colleague: Steven M. Arnold

Assignment:

One method for overcoming the CTE mismatch in MMCs is to decrease the CTE of the matrix material by introducing particulates of another material. Dr. Donovan will conduct analytical studies using the generalized method of cells to examine the influence of inclusion (particulate) aspect ratio and plasticity on the effective thermal and mechanical properties of the hybrid matrix material. Results will be compared to experimental observations.

---

### **Effects of Local Architectures on Microcomposite Global Properties**

The purpose of this investigation is to determine the effect that local microstructural architectures have on the global mechanical properties of microcomposites. One such microcomposite consists of BS50 ceramic particles bound together with a polyamide, LaRC Si, that is being developed at NASA Langley. During the summer of 1995 a series of tensile tests were performed on standard dogbone specimens made from a microcomposite consisting of BS50 ceramic particles at 90% volume fraction bound with LaRC Si. The tests results indicated that one side of the specimen had a significantly higher modulus than the other. A study of SEM micrographs indicated that relatively large (on the order of 10-20 microns) particles formed from the ceramic particles (on the order of 1-2 microns). By applying a point counting technique it was determined that the volume fraction of conglomerate particles varied from .34 to .28. The generalized method of cells, GMC, was used to analyze the tensile specimen by first determining the material properties of the conglomerate structures. This was done using an eight celled representative volume element (RVE). One of the cells was assigned material properties associated with the ceramic and made to fill 95% of the volume of the RVE. The remaining cells were assigned material properties associated with LaRC Si. The overall properties of the microcomposite were determined from an RVE that consisted of One "conglomerate" particle and a number of smaller particles that were assumed to consist of 100% ceramic ( see figure 1). the results of the analysis revealed that the as the volume fraction of conglomerates increased the modulus of elasticity also increased. In this study the volume fraction of the ceramic also increase as the volume fraction of the conglomerate increased, qualitatively matching the results of the tensile test.

Another study was performed using a similar two particle RVE and maintaining a constant volume fraction of ceramic. This study indicated that the volume fraction of the conglomerates had little effect on the modulus of elasticity. However a substantial decrease in the coefficient of thermal expansion was observed (see figure 2). This indicates that local microstructural architectures play a vital role in determining global structural properties.

Another study was performed on a microcomposite consisting of Mo(Si)<sub>2</sub> as the matrix and (Si)<sub>3</sub>(N)<sub>4</sub> as the inclusion phase. In this study an eight celled RVE was used with one cell assigned for the inclusion phase and the remaining cells assigned matrix properties. For this study the aspect ratio of the inclusion phase was varied from one to fifteen while keeping the volume fraction of inclusion constant. The results indicated that the aspect ratio had little

effect on the modulus of elasticity. However, the coefficient of thermal expansion in the longitudinal direction increased with increasing aspect ratio and the transverse CTE decreased with increasing volume fraction (see figure 3 and 4).

In addition to these studies the analytic foundation for including piezoelectric effects in generalized method of cells. The preliminary results indicate that local microstructures will have a significant effect on the piezoelectric response of these microcomposites. Also, it appears that the overall mechanical properties of the microcomposites will be effected by the presence of an electric field.

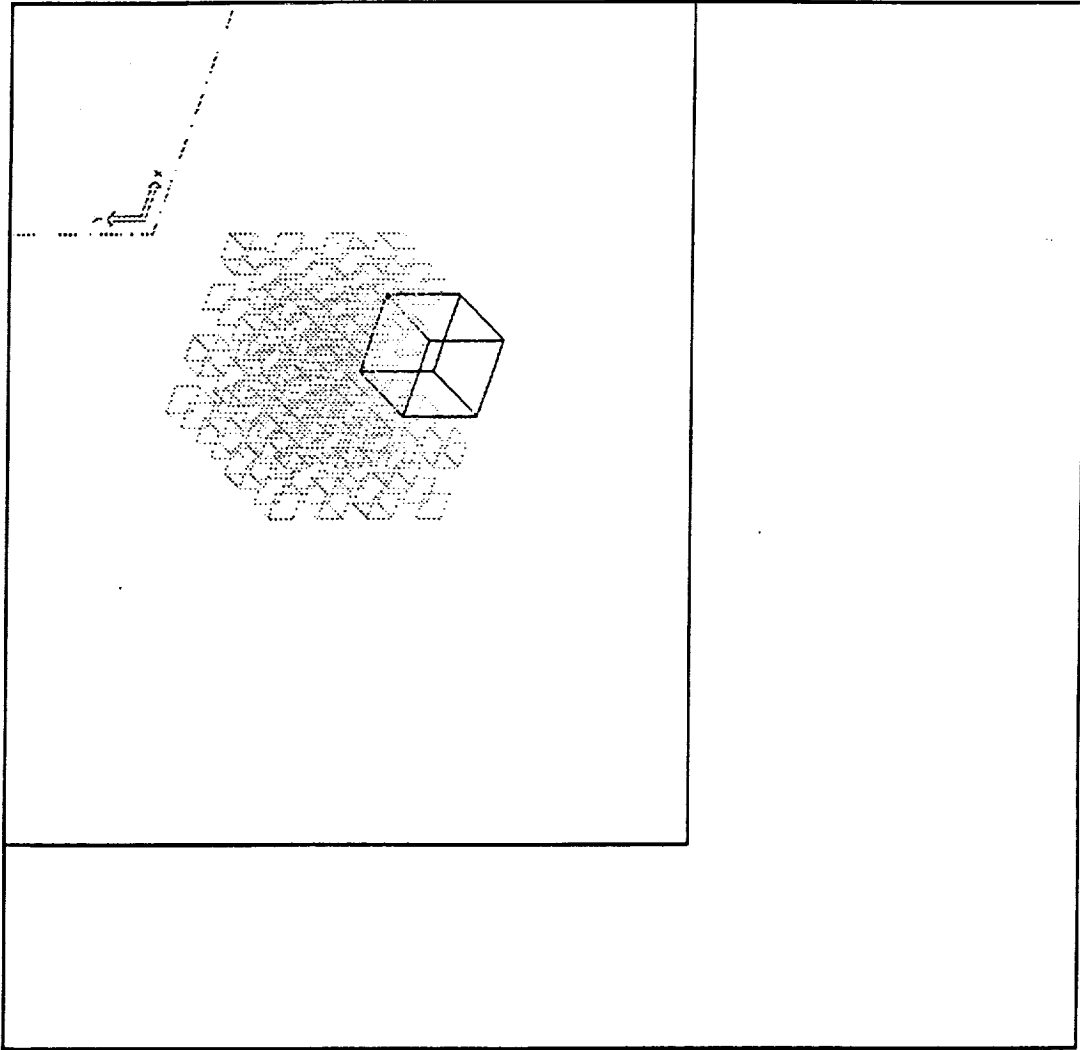

Figure 1

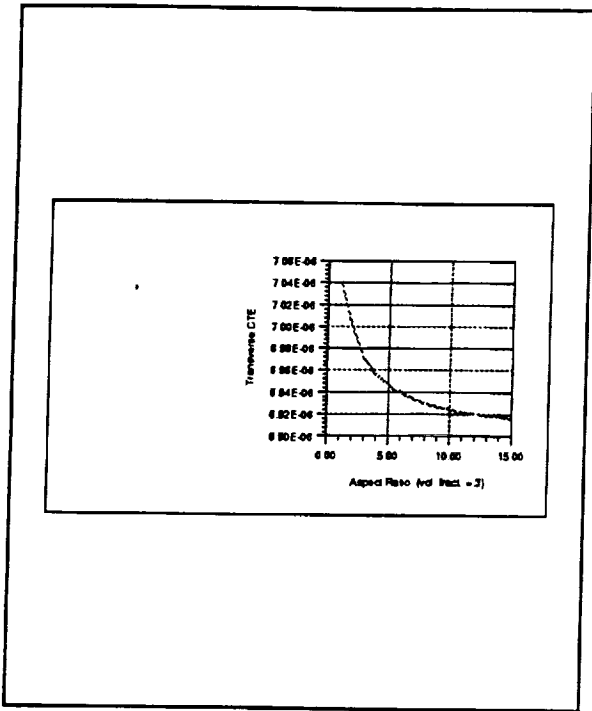

Figure 2

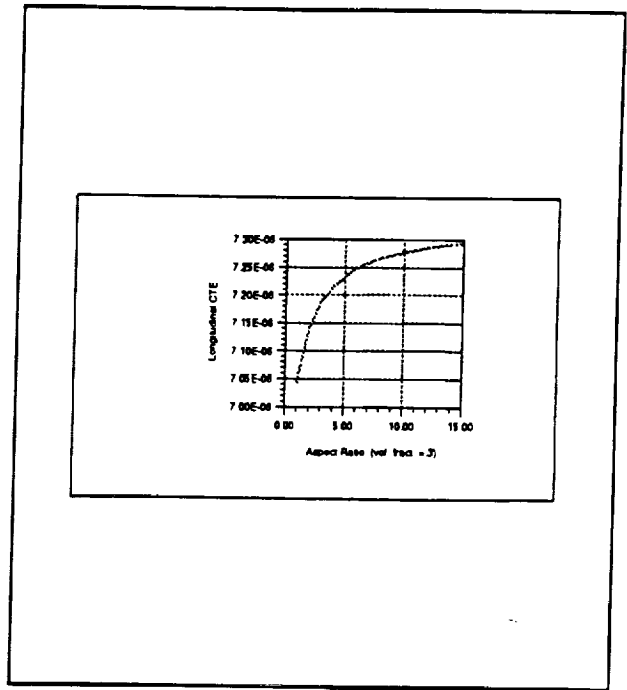

Figure 3

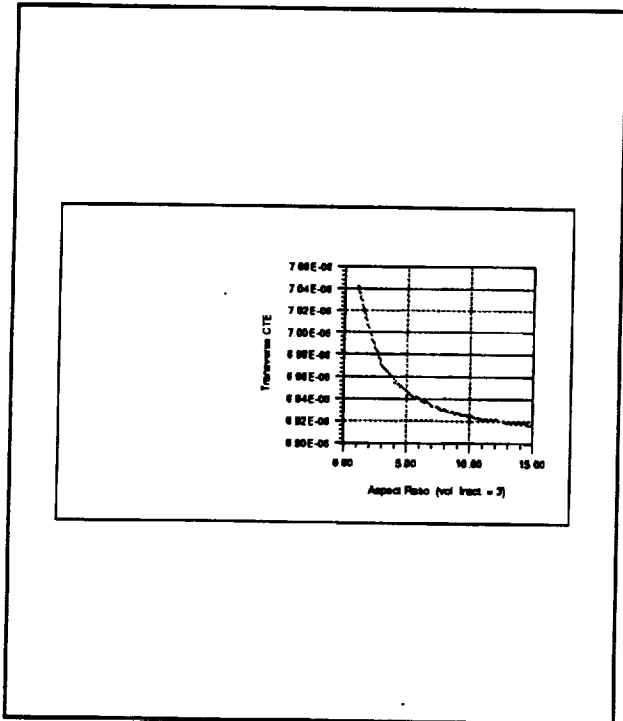
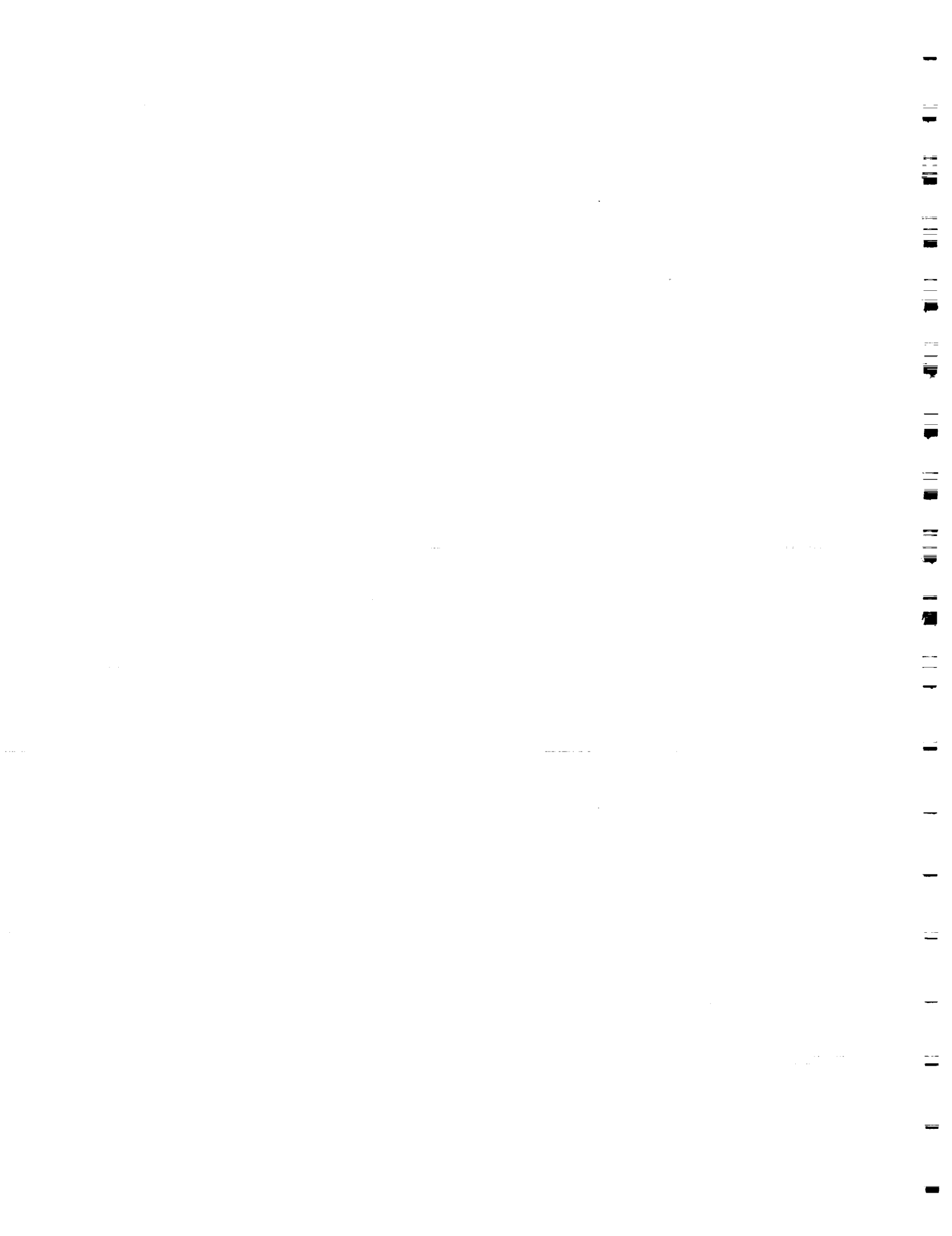

Figure 4





Name: Malik E. Elbuluk  
Education: D.Sc., Electrical Engineering  
Massachusetts Institute of Technology

Permanent Position: Associate Professor, Electrical Engineering  
University of Akron

Host Organization: Power Technology Division  
Colleague: M. David Kankam

Assignment:

Perform comparative study of sensorless control of AC machine drives: Evaluate available techniques for novel technology; recommend a sensorless approach for implementation in field-oriented control of AC machine drives, with particular emphasis on space, aerospace and ground applications. Document study in a final report.

---

## **Identification Schemes for Speed Sensorless Control of Induction Motors**

### **Summary**

The induction motor has been the workhorse of the industry for many years. In particular, the squirrel cage motor is one of the most important ac machines because of its low cost, high reliability, low inertia and high transient torque capacity. Significant advances in power electronics have permitted the implementation of sophisticated methods for control of induction motors, using field-oriented control (FOC) which allows decoupling and separate control of the torque and flux components of the stator currents. Two types of field-oriented control are available. One is the direct field-oriented control which regulates the rotor flux using direct measurements of rotor flux magnitude and position. The other is the indirect field-orientation in which the rotor flux is regulated by the slip frequency, the stator currents and the rotor speed.

There are a number of trends and tradeoffs involved in implementing the different variations of field-oriented control. First, most of the field orientation methods require precise estimation of either the rotor position or speed. This implies the need for speed and position sensors such as shaft-mounted tacho-generators, resolvers or digital shaft position encoders. These speed sensors lower the system reliability, especially in defective environment and, also, require special attention to measurement noise. Second, the direct field-oriented scheme requires the rotor flux which is measured by using sensors such as Hall effect sensors or search coils. These sensors degrade the performance and reliability of the drive system. Third, although the indirect field-oriented control scheme is simple and preferred, its performance is highly dependent on the machine parameters. Finally, the implementation of direct field orientation has an open-loop integration that give problems at low speeds.

The research in induction motor drives, for the past fifteen years, has focused in improving the different field oriented schemes to remedy some of the above problems. In particular, much work has been developed in decreasing the sensitivity of the control system to motor parameters, and estimating rather than measuring the rotor flux or speed from the terminal voltages and currents. Thus, eliminating the flux and speed sensors and achieving sensorless control. These estimators are, also, known as observers. A third control scheme, known as direct self control (DSC) requires only stator parameters, and has been developed as an alternative sensor-less drive.

Fig 1 shows a general sensorless drive. Measurements of the terminal voltages and currents are fed to observers for estimating the rotor flux magnitude, angle and speed. The estimated quantities are compared with their respective command values. The errors are fed into the controllers to the power electronic converters.

A number of approaches for flux and speed observers have been developed in the literature. In the past two years the University of Akron, in cooperation with the Power Technology Division at NASA Lewis Research Center, has been investigating and developing an induction motor drive system for aerospace applications. The motor drive system implemented uses a direct field orientation. A rotor flux observer has been developed to overcome problems encountered in other flux observers found in the literature. However, the observer requires the induction motor rotor speed and a shaft encoder for speed sensing.

The research done under the 1996 summer Fellowship is an extension to eliminate the speed sensor. The work has focused investigating the available literature on sensorless techniques for induction motor drives. More than thirty approaches have been studied and assessed. A followup of the study is to adopt either one of the studied techniques or combine the attributes of many techniques to obtain a better sensorless drive.

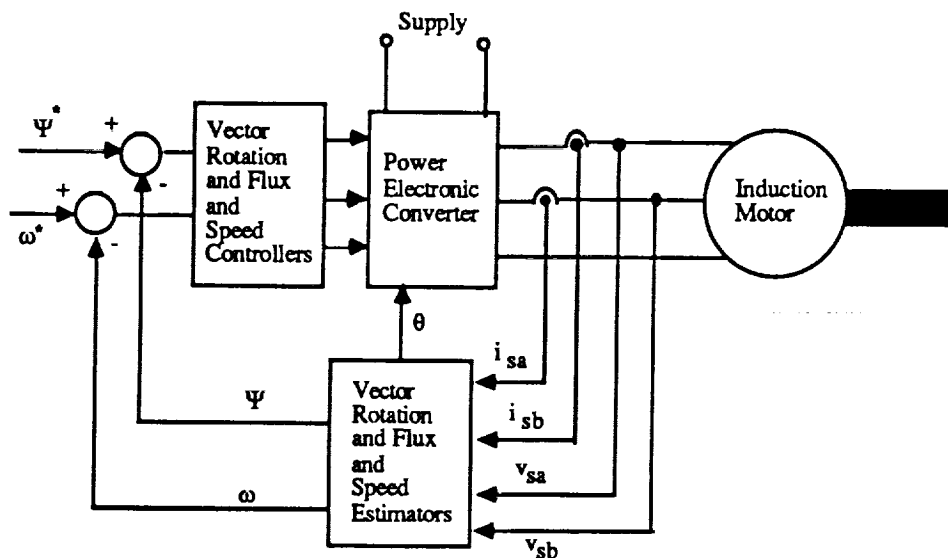

Fig. 1 Speed Sensor-less Field oriented Control System

Name: Carol L. Emrich  
Education: MS, Electrical Engineering  
University of Central Florida

Permanent Position: Senior Research Engineer, Electrical Engineering  
University of Central Florida

Host Organization: ACTS Project Office  
Colleague: Ronald J. Schertler

Assignment:

The ACTS Project Office has developed an ultra small aperture transceiver which is being tested with ACTS. Applications such as ISDN and compressed video are being tested. Fellow will assist in testing and characterizing the performance of these applications as well as participate with project engineers in implementing and testing new applications. Fellow will investigate the adaptation of the USAT to monitoring photovoltaic power system in a SCADA type arrangement. The goal will be to develop a system concept for operations with ACTS as well as a detailed system design for a USAT which incorporates elements of the current ACTS USAT terminal.

---

My major accomplishment was to develop a method for analyzing ACTS beacon data collected at 150 msec intervals. The sampling rate resulted in large files in excess of 60 Mbytes for one week of data. This precluded analysis in a PC/Windows environment. The next logical place was to use the SUN computer. The SUN computer did not have a statistics package, but it did have a C compiler so I could create my own.

Sampling at 150 msec intervals results in 57600 samples/day or 4032000 samples/week. Originally I wrote my programs to expect these numbers of lines of data. However, I found that the sampling period varied and there were portions of missing data. So I modified the programs to check for 24 hours, to determine where the next day began. I also wrote to additional programs; one to go through the data files and check for missing data and the other to print the first and last lines of data, and the number of samples in the file.

I wrote three statistics programs. One to calculate the daily sample number, minimum, maximum, and average.. Another program used the output from the first and calculated the weekly sample number, minimum, maximum, and average. The third program used the number of samples and averages from the first two and calculated the daily and weekly standard deviations.

Run times were a problem. The first program took over three hours to process one week of data. The second program took seconds and the third over three hours. This was mainly due to the large size of the data file and the fact that I could only create an array large enough to hold one day at a time. Therefore, I had to do a separate access of the data file for each day. The decision was made to try using the CRAY computer to minimize the run times.

My C programs compiled nicely on the CRAY but had to be submitted as batch jobs because they were CPU time intensive and exceeded the interactive limits. My mentor also suggested that the three programs be combined into one to simplify the analysis procedure.

I discovered that the CRAY would allow me to create an array that would hold an entire week of data, thereby eliminating the multiple dutiful accesses, which are costly time-wise. So I wrote a new program that would hold a week of data in a two dimensional array and perform the calculations sequentially. This worked well, running in about 48 minutes and using less than 1000 seconds of CPU time. Because of the large array and long run time the program has to be submitted as a batch job. For the same reasons it is given a low priority and is run during the night.

The program outputs the results to a formatted report file. To test the results of the calculations, I ran my program on a data set small enough to be handled by MATLAB. The results generated by my program were consistent with those of MATLAB.

At my mentor's request I gave a presentation of the program to interested colleagues in the ACTS program. I prepared view graphs and handouts for the attendees. The presentation, including questions, lasted about an hour and was well received. I also prepared a more detailed packet for my mentors Roberto Acosta and Ron Schertler.

My second project for this summer was to outline an experimental plan to test the ultra small aperture terminals (USATs) in a supervisory control and data acquisition (SCADA) network using the ACTS Ka band. Roberto Acosta and I spent a significant amount of time discussing the best way to proceed with this. We decided the first step should be to characterize the network of two USATs located within the fixed Tampa/Orlando beam, with emphasis on rainfade.

Florida provides an excellent climate for testing rainfade because of the intense rainfall during the rainy season. The plan includes locating two USATs in Florida for about six weeks during the rainy season or possibly two six week periods, one during the rainy season and one during the dry season. The proposal is still in outline form and will be expanded after I return to Florida.

The second phase will be to set up a full scale SCADA network at Savannah State, a historically black college. The network would supervise stand-alone photovoltaic systems, monitoring various system parameters, and exercising control by shedding loads, etc. Salary money had been added to an existing contract between NASA Lewis Research Center, Florida Solar Energy Center, and Savannah State to provide for my time to continue to work on this project while in Florida.

This experience as a summer faculty fellow has been a very positive one for me. NASA Lewis Research Center provided an excellent working environment in my opinion. Ron Schertler assigned Roberto Acosta to work with me this summer, because of his technical expertise in my chosen area. Roberto was an excellent mentor, always available for questions and providing sufficient direction without hampering creativity. I also found all the ACTS staff members I encountered to be very talented, professional, and helpful. I look forward to returning next summer.

Name: Patrick M. Flanagan  
 Education: Ph.D., Mechanical Engineering  
 University of Cincinnati

Permanent Position: Associate Professor, Mechanical Engineering  
 Cleveland State University

Host Organization: Space Propulsion Technology Division  
 Colleague: George C. Madzsar

Assignment:

During this summer program, Professor Flanagan will complete laboratory testing of the breadboard self-diagnostic, self-compensating (SDSC) accelerometer system. Self-compensating parameters evaluated during this program will include: (1) detecting and adjusting output acceleration data due to a change in ambient temperature that shifts accelerometer sensitivity; and (2) detecting and correcting the accelerometer's output signal due to thermal shock. Target system self-compensation software will be developed and tested for accuracy and reliability using breadboard SDSC test facility. Final tests will evaluate both self-diagnostic and self-compensation performance of the target system.

### Development and Testing of a Dedicated Self-Diagnostic, Self-Compensating (SDSC) Accelerometer System

This work included the development and testing of a dedicated Self-Diagnostic, Self-Compensating (SDSC) accelerometer system. The SDSC system consists of a portable PC interfaced to RTD 3400 high speed data acquisition and control card. The SDSC electronics unit interfaces the SDSC accelerometer with the RTD 3400. This system generates an adjustable, self-windowing, periodic chirp function to drive the piezoelectric element. The drive function is loaded into a 4096 word FIFO with gain control. A diagram of the SDSC system operation is shown in Figure 1.

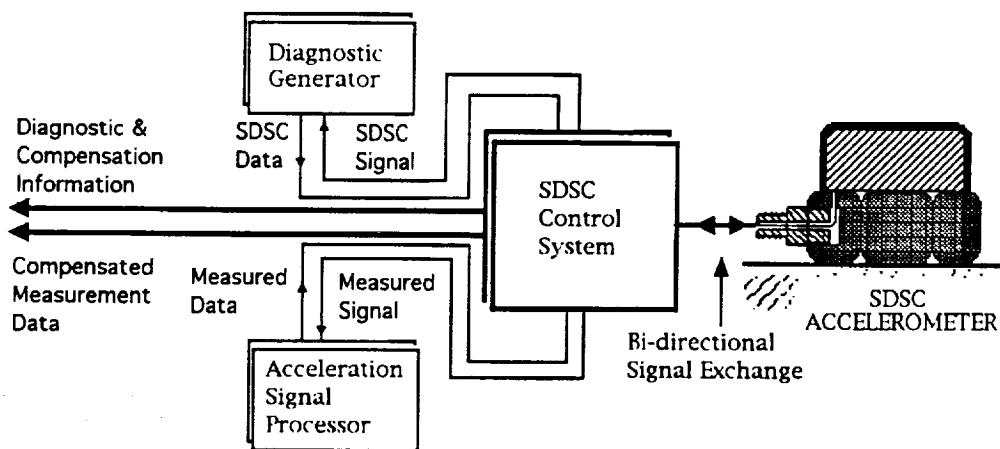

Figure 1, Schematic of SDSC control system for detecting soft failures, identifying sensor conditions that affect the accuracy of acceleration data, issue warnings related to soft failures and correct acceleration data when possible.

SDSC technology is designed to help verify piezoelectric accelerometer operation and, in certain cases, compensate for soft failures. The dedicated SDSC piezoelectric accelerometer system is able to detect both soft and hard failures, issuing specific warnings and when possible correct the sensor's output signal. Self-compensating parameters evaluated included: (1) measuring the change in accelerometer sensitivity due to a change in ambient temperature; (2) compensating output acceleration data due to a change in ambient temperature; and (3) detecting and correcting the accelerometer's output signal due to thermal shock. Test results using a piezoelectric element show that both ambient temperature (Figure 2) and the effects of thermal shock on the piezoelectric output signal can be predicted using SDSC data.

An SDSC function to measure changes in sensitivity as a function of ambient temperature was developed for a SD (Self-Diagnostic) compression-mode accelerometer. Back-to-back calibration technique in a temperature controlled environment was used to calculate this SDSC function. SDSC data was processed to develop a relationship between temperature and percent deviation in accelerometer sensitivity. SDSC function relating the resonances of the SDSC data to the percent deviation in accelerometer sensitivity due to a shift in ambient temperature is shown in Figure 3. This work was presented, in part, at the AIAA/ASME/SAE/ASEE 32th Joint Propulsion Conference, July 1-3. The paper, *Design of a Self-Compensation System for Piezoelectric Accelerometers* [AIAA-96-2935], discussed the two data processing techniques studied during this research program.

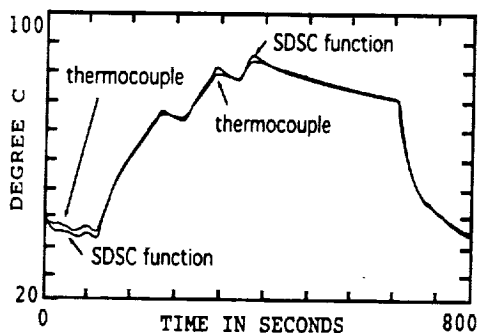

Figure 2, Typical test results using a SDSC Function to measure ambient temperature. In this test, SDSC function data from a small piezoelectric element was compared to a thermocouple in a temperature controlled oven. Results show the potential of measuring temperature while collecting acceleration data.

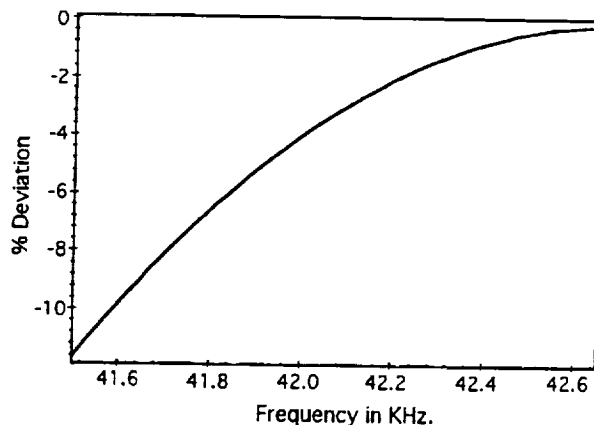

Figure 3, change in the resonant frequencies of the autocalibration function versus percent deviation in accelerometer sensitivity.

Name: Russell W. Gruhlke  
Education: Ph.D., Optics  
University of Rochester

Permanent Position: Associate Professor, Physics  
Mount Vernon College

Host Organization: Instrumentation and Control Technology Division  
Colleague: Margaret L. Tuma

Assignment:

Complete a literature search on experimental optical NO<sub>x</sub> sensors that have been fabricated. From information obtained, determine a viable NO<sub>x</sub> optical sensor concept that can be fabricated at NASA Lewis and implemented in an engine outlet.

---

### No<sub>x</sub> Emission Sensors

#### Summary

My participation in the Summer Faculty Program at Lewis was spent familiarizing myself with No<sub>x</sub> emission sensors, determining a strategy for future No<sub>x</sub> sensor research/development, and designing a No<sub>x</sub> sensor.

A literature search was undertaken to familiarize myself with emissions sensor technology. In general, such sensors are either electronic or fluorescence based. Electronic based sensors detect emissions with good sensitivity but poorly discriminate one species of emissions pollutant from another. Fluorescence based sensors exhibit good discrimination of emissions species but suffer from low signal to noise ratio.

Based on this assignment, I pursued a strategy of combining the best of both sensor technologies into a single sensor. The result is an integrated thin film fluorescent sensor. This device retains the good discrimination properties of the fluorescent based sensors while optimizing the signal to noise ratio. Furthermore, the invention integrates optics and electronics in a thin film geometry compatible with VLSI technology. An attached patent disclosure describes this invention in further detail.

I am in the process of submitting a proposal, jointly with my NASA sponsor Dr. Margaret Tuma, to further investigate this hybrid sensor technology.

1. The first part of the document is a list of names and their corresponding addresses.

2. The second part of the document is a list of names and their corresponding addresses.

3. The third part of the document is a list of names and their corresponding addresses.

4. The fourth part of the document is a list of names and their corresponding addresses.

5. The fifth part of the document is a list of names and their corresponding addresses.

6. The sixth part of the document is a list of names and their corresponding addresses.

7. The seventh part of the document is a list of names and their corresponding addresses.

8. The eighth part of the document is a list of names and their corresponding addresses.

9. The ninth part of the document is a list of names and their corresponding addresses.

10. The tenth part of the document is a list of names and their corresponding addresses.

11. The eleventh part of the document is a list of names and their corresponding addresses.

12. The twelfth part of the document is a list of names and their corresponding addresses.

13. The thirteenth part of the document is a list of names and their corresponding addresses.

14. The fourteenth part of the document is a list of names and their corresponding addresses.

15. The fifteenth part of the document is a list of names and their corresponding addresses.

16. The sixteenth part of the document is a list of names and their corresponding addresses.

17. The seventeenth part of the document is a list of names and their corresponding addresses.

18. The eighteenth part of the document is a list of names and their corresponding addresses.

19. The nineteenth part of the document is a list of names and their corresponding addresses.

20. The twentieth part of the document is a list of names and their corresponding addresses.

21. The twenty-first part of the document is a list of names and their corresponding addresses.

22. The twenty-second part of the document is a list of names and their corresponding addresses.

23. The twenty-third part of the document is a list of names and their corresponding addresses.

24. The twenty-fourth part of the document is a list of names and their corresponding addresses.

25. The twenty-fifth part of the document is a list of names and their corresponding addresses.

26. The twenty-sixth part of the document is a list of names and their corresponding addresses.

27. The twenty-seventh part of the document is a list of names and their corresponding addresses.

28. The twenty-eighth part of the document is a list of names and their corresponding addresses.

29. The twenty-ninth part of the document is a list of names and their corresponding addresses.

30. The thirtieth part of the document is a list of names and their corresponding addresses.



Name: R. David Hampton  
Education: Ph.D., Mechanical Aerospace Engineering  
University of Virginia

Permanent Position: Assistant Professor, Mechanical Engineering  
McNeese State University

Host Organization: Space Experiments Division  
Colleague: William O. Wagar

Assignment:

The Microgravity Measurement and Analysis Branch has been assigned the responsibility to assess the capability and performance of the Active Rack Isolation System (ARIS), an integral part of the International Standard Payload Rack (ISPR) planned for installation within the International Space Station (ISS) United States Lab Module. The primary purpose of the ARIS is to isolate microgravity payloads from vibratory and rigid-body accelerations. The purpose of the ARIS summer faculty fellowship is to develop a mathematical model of the Active Rack Isolation System (ARIS). This model will be used by NASA to analyze potential ARIS state-space controllers and to help assess the overall performance of the ARIS. The development of the ARIS model entails deriving the mathematical relationships between the ARIS, the ISPR and payloads. Detailed specifications of the ARIS will be acquired from Boeing, the builders of ARIS, and incorporated into the model. If time permits, the summer faculty fellow will devise state-space controllers for the ARIS math model and perform preliminary analysis of these controllers.

---

**Enhanced Dynamic Modeling of ARIS (Active Rack Isolation System)  
and Optimal Centralized Control of MIM (Microgravity Isolation Mount)**

Dr. Hampton pursued two objectives during his summer fellowship:

- (1) The development of an enhanced dynamic model of NASA's Active Rack Isolation System (ARIS).
- (2) The development of an optimal centralized controller for the Microgravity Isolation Mount (MIM) developed by the Canadian Space Agency (CSA).

This research contributes to ongoing efforts under NASA Cooperative Agreement #NCC3471, "Support of ARIS and MIM for Isolation of Space Science Experiments: Dynamic Modeling, Optimal Controller Synthesis, and Data Processing and Analysis" (May 1, 1996 through April 30, 1997). The controller design work for MIM was begun under NASA Lewis Cooperative Agreement #NCC3-365, "Optimal Controller Synthesis for Isolation of Space Science Experiments by the Microgravity Isolation Mount" (October 12, 1994 through April 30, 1996).

For his primary effort of the summer, Dr. Hampton developed a linearize dynamical model of ARIS, in algebraic state-space form, using "Kane's Dynamics." This method produces relatively simple equations of motion for complicated dynamical systems, with the automatic elimination of "noncontributing" (i.e., nonworking) forces and moments. Each of ARIS's eight actuators was modeled using five generalized coordinates, resulting in a mathematical representation of the system with forty generalized coordinates. The model employs forty generalized speeds, viz., the time derivatives of the generalized coordinates. It consists of forty dynamical and forty kinematical equations, in a state-space form which can be used for straightforward optimal controller design by the methods being used to isolate MIM.

Dr. Hampton also developed six optimal controllers for MIM, using extended H2 synthesis methods to produce controllers with a frequency-tailored form of acceleration feedback. These state-space controllers were sent to CSA for final testing against their high-fidelity, nonlinear MIM simulation, and use on Mir in microgravity science experiment isolation.

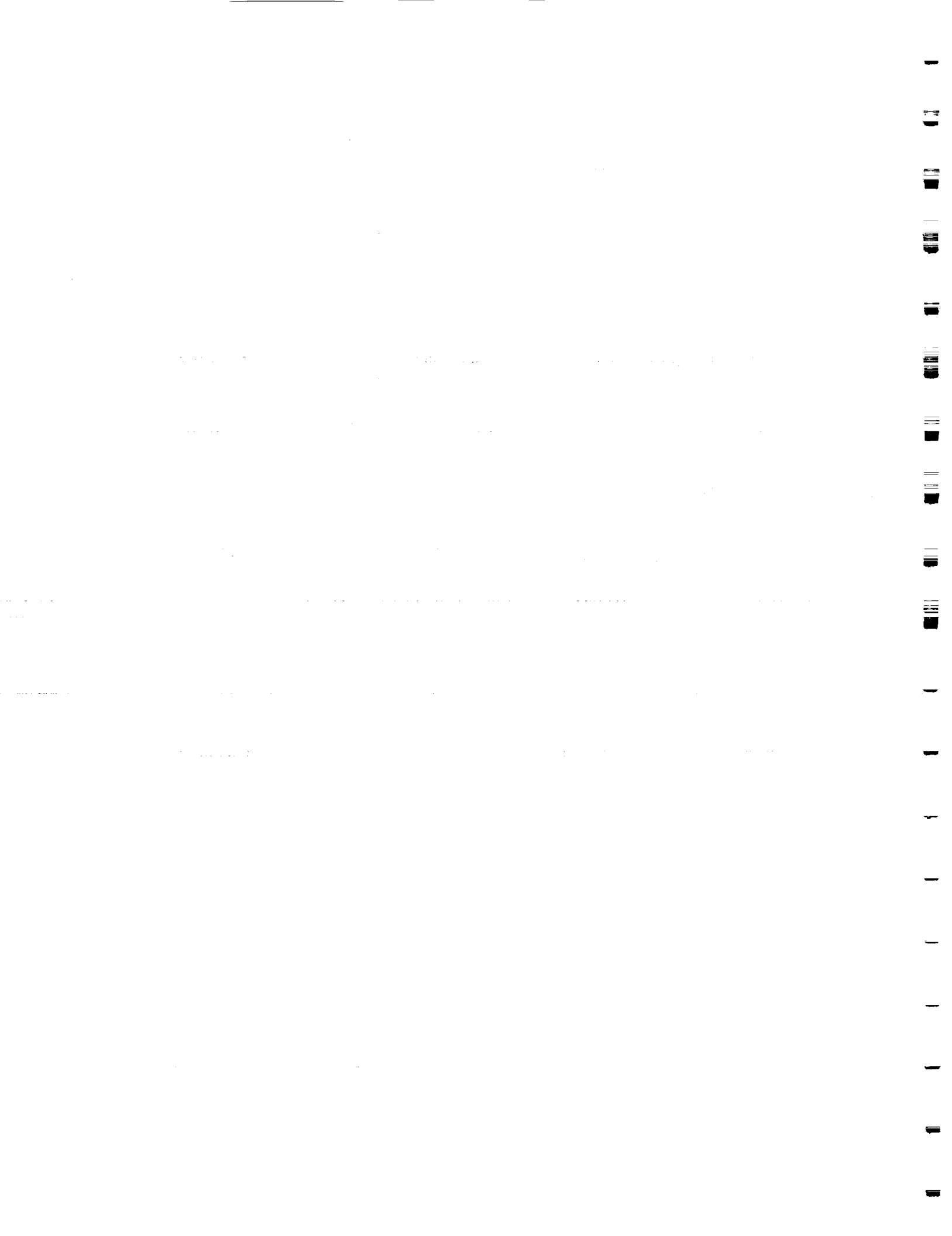

Name: John A. Heminger  
Education: Ph.D., Mathematics  
Purdue University

Permanent Position: Assistant Professor, Mathematical Sciences  
University of Akron

Host Organization: Internal Fluid Mechanics Division  
Colleague: David A. Jacqmin

Assignment:

Research will be in the area of surface-tension/free-surface flow. Work will be directed towards computing low Reynolds number fiber coating flows. The free surface as well as the flow field of these flows must be found. The procedure to find this surface will most likely be iterative iteration steps. The stability of computed steady flows will be investigated. A time-dependent flow code will be developed for investigating steady flow breakdown and bubble formation.

---

### Investigation of Flow within a Cylindrical Tube for Several Capillary Numbers

We considered a cylindrical container open at the top and filled to a given level with an incompressible liquid. Along the axis of the tube is a solid cylindrical rod of infinite length which is being moved along the axis in the direction of the fluid. The rod reaches to the bottom of the container and passes through it. The motion of the rod drives a flow within the fluid and, in combination with the surface tension and viscosity, shapes the surface of the liquid. This models a process used to coat wires.

We investigated the flow and the surface shape for several capillary numbers. The capillary number, denoted by  $Ca$ , is defined as  $Ca = uV/s$ , where  $u$  is the viscosity,  $V$  is the fluid speed, and  $s$  is the surface tension. Large values of  $Ca$  mean that viscous effects dominate capillary effects.

We assumed the flow in the container was axisymmetric. Then we needed only consider a planar region with straight sides at the left, bottom, and right sides, and with the free surface at the top. We took the left side to be an edge of the descending rod. The continuity and conservation of linear momentum equations together with a kinematic condition for the position of the free surface were solved to determine the pressure and velocity of the liquid, and the position of the free surface.

The equations were solved numerically using the commercial software POLYFLOW. This employs the finite element method with continuous biquadratic elements for the velocity field, continuous bilinear elements for the pressure, and continuous quadratic elements for the free surface.

Initially the free surface was taken as a horizontal straight line. The end at the rod was expected to be drawn downward. Care was taken in designing a finite element mesh so that the elements maintained a reasonable shape during this deformation and still provided detail in the appropriate areas. Figure 1 shows the initial mesh and a sample deformation.

We took the normal velocities to be zero along all non-free surfaces. At the bottom and right sides the tangential velocities. The tangential velocity along the entire left side was gradually increased to 1.8 cm/sec (viscosity = 10 g/cm/sec, surface tension = 30 g/sec/sec, density = 1 g/cm/cm/cm) which corresponds to  $Ca = .6$ . The resulting stream function is shown in Figure 2.

Next, the velocity along the left side was gradually stepped upward with increasing depth. Several such trials were made. Figure 3 shows the stream function for a stepped linear velocity profile of 0 cm/sec at the top and 40 cm/sec at the bottom ( $Ca = 13.33$ ).

In all cases tried, it was found that a point in time was reached beyond which it was extremely difficult to progress due to the time steps tending to zero. The stream functions in figures 2 and 3 show that this occurred before the freesurface reached a steady state.



Figure 1. Sample mesh and deformed mesh.



Figure 2. Stream function for velocity = 1.8 cm/sec.

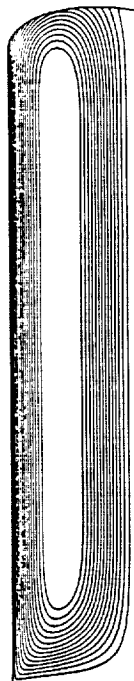

Figure 3. Stream function for linear velocity profile

Name: Danny E. Hubbard  
Education: Ph.D., Chemistry  
Clark Atlanta University

Permanent Position: Assistant Professor, Chemistry  
Grambling State University

Host Organization: Materials Division  
Colleague: Michael A. Meador

Assignment:

The proposed project involves the synthesis and processing of new polyimides for aircraft engine applications. This is a continuation of the research that Dr. Hubbard started last summer. The objective is to develop new polyimide formulations that replace PMR-15, a high temperature polyimide developed at Lewis in the early 1970s. PMR-15 is made from a mutagenic diamine and has limited options in terms of processing. We are looking to develop new polyimides which are not prepared from carcinogenic or mutagenic monomers and which can be processed by cost effective techniques, e.g., resin transfer molding.

---

### **Polymerizable Monomer Reactants Synthesis of Aryl Ethers 1996**

#### **Summary**

As part of our investigation on forming modified polyimides for high temperature applications, we were able to complete the synthesis and characterization of two important monomers. We prepared both 2,2'-Bis(p-aminophenoxy)-1,1'-biphenyl and 2,2'-Bis(p-aminophenoxy)-1,1'-binaphthyl. In addition to the synthesis of these compounds we outlined an efficient procedure to scale up the production of the monomers to at least a fifty gram quantity. Once these compounds were prepared and characterized we prepared a polymer from the reaction of 2,2'-Bis(p-aminophenoxy)-1,1'-biphenyl, 3,3',4,4'-Benzophenonetetracarboxylic dimethyl ester (BTDE), and Nadic ester. The resulting polyimide was studied thermomechanically using differential scanning calorimetry (DSC), thermal gravimetric analysis (TGA), and thermal mechanical analysis (TMA).

The results of the thermomechanical data show that modified polyimides made with bulky aryl ethers (e.g., aryl ethers from this study) are comparable to similar data on NASA's PMR-15 polyimide. Upon post cure of this material we have observed a glass transition of 342 °C. Based on the experimental data obtained to date we expect that the polyimide materials from this study will have application in the range of 600 °F to 700 °F. At this time we have been able to prepare neat resin disks for polymer molecular weights of 1500, with n=2; using 2,2'-Bis(p-aminophenoxy)-1,1'-biphenyl (BPAB) and Nadic ester (NE) end caps.

We conclude that these polymers have properties similar to that of PMR polyimides. Also, a significant contribution to the aeropropulsion industry can be realized using these polymer materials if further studies are done.

1. The first part of the document discusses the importance of maintaining accurate records of all transactions.

2. It then goes on to describe the various methods used to collect and analyze data.

3. The next section covers the different types of data that can be collected and how they are used.

4. Finally, the document concludes with a summary of the key findings and recommendations.

5. The following table provides a detailed breakdown of the data collected during the study.

Category	Sub-category	Value
Group A	Item 1	100
	Item 2	200
	Item 3	300
	Item 4	400
Group B	Item 1	150
	Item 2	250
	Item 3	350
	Item 4	450

6. The data shows a clear trend of increasing values over time, which is consistent with the hypothesis.

7. These findings have important implications for the field of research and should be taken into account.

8. Further research is needed to explore the underlying causes of these trends and to develop effective interventions.

9. The results of this study provide a solid foundation for future research and practical applications.

10. In conclusion, the study has successfully identified key trends and provided valuable insights into the phenomenon.

11. The findings are presented in the following table, which summarizes the key data points.

Year	Value
2010	100
2011	150
2012	200
2013	250
2014	300
2015	350
2016	400
2017	450
2018	500
2019	550
2020	600

Name: Mounir B. Ibrahim  
Education: Ph.D., Mechanical Engineering  
Bradford University (U.K.)

Permanent Position: Professor, Mechanical Engineering  
Cleveland State University

Host Organization: Propulsion Systems Division  
Colleague: Terry M. Sanders

Assignment:

The success of the HSR and AST programs are highly dependent upon developing a low emissions combustor. NO<sub>x</sub> emissions are directly affected by the fuel injection method and subsequent fuel-air mixing. Therefore, fuel spray research is essential in the development of low emissions combustors. The summer faculty's task will consist of performing a literature search on low NO<sub>x</sub> combustor research, reducing emissions and nonreacting spray data, correlating spray mass distribution with the reduced data, estimating appropriate similarity parameters between the reacting and nonreacting spray data, and, time permitting, designing an experiment to measure mass flux distribution in a nonreacting spray.

---

### Review of Experimental Data on Autoignition Characteristics of Hydrocarbon Fuels

The summer work has mainly focused on the autoignition characteristics of hydrocarbon fuels. In addition some time was spent at SE-5 cell in order to closely understand and perform accurate experiments on fuel injectors using the 2-D Phase Doppler Particle Analyzer (PDPA). Valuable first hand experiences were gained for adjusting the apparatus and running it to obtain repeatable and accurate results. Checks on the Doppler signal under different input parameters to the system (high voltage, threshold, velocity and droplet size ranges,...etc.) were some of the difficult exercises that should be conducted in order to obtain reliable PDPA data.

As for the autoignition characteristics of hydrocarbon fuels; the autoignition is defined as: "when a reactive mixture is formed, raised to a definite temperature and pressure, and then left alone, it may burst into flame after a certain time." At the onset of the autoignition the following is observed: 1) rapid rise in temperature, 2) emission of visible radiation and 3) rapid chemical reactions. The ignition delay time comprises a series of overlapping physical delay (droplet formation, heating, vaporization, diffusion, and mixing with air) and chemical delay (time elapsed from the instant a combustible mixture has been formed until the appearance of a hot flame). In homogenous mixture, the autoignition delay time is dependent upon temperature, pressure, fuel concentration, and oxygen concentration.

Differences among the experimental data gathered to date are due to:

- 1) definition of the autoignition delay time (particularly the end of this period),
- 2) the autoignition delay time is a path-dependent phenomena,
- 3) the great variety of equipment used to examine the phenomena:
  - a) Constant volume heated bombs,
  - b) Motored & fired reciprocating engines and rapid compression machines,

- c) Shock tubes,
- d) Continuous flow rig.

An illustration of the difficulty in measuring the autoignition delay time is the factor of two difference in the results of two researchers (Spadaccini, and Taback ). Both of them conducted experiments on JP-4 fuel and found that the time is inversely proportional to the pressure to the power 1.8 (Spadaccini) and 0.9 (Taback).

The autoignition time delay is correlated using the Arrhenius expression:

$$t = A (p^{-n})(\phi^{-m}) \text{EXP} (E/RT)$$

- where : t = ignition delay time (ms),  
 A, n, m = constants,  
 p = pressure (atm),  
 $\phi$  = equivalence ratio,  
 E = global activation energy (kcal/mole),  
 R = universal gas constant  
 T = mixture temperature (k)

Table below shows a summary of some of the data gathered:

Type of Fuel	Temperature °C	Pressure atm. (n)	Equi. Ratio (m)	Velocity (m/s)	E (kcal/-mol)
Acetylene	514 - 546	1 - 3 (0.66)	0.2 - 0.4 (0.75)	11 - 20	30.6
Cetane	627 - 930	10.1-30.5 (2.0) (1.0)	0.3 - 1.0	20.7 - 74.2	43.8 - 50.4
ERBS	686 - 997	10.2-30.4 (2.0) (1.0)	0.3 - 1.0	23.5 - 95.5	39.6 - 43.0
Ethylene	540 - 670	1 - 10 (0.75)	0.2 - 0.7 [0.27 @ 1 atm, 0.55 @ 5 atm.]	7 - 30	37.2
Jet-A	620 - 690	1 - 2 (0.98)	0.17 - 0.6 (0.37)	13 - 21	29.6
Jet-A	662 - 721	10.0-31.0 (2.0) (1.0)	0.3 - 0.7	22.2 - 103.3	35.1 - 37.8
JP-4	666 - 958	10.1-30.0 (2.0) (1.0)	0.3 - 1.0	23.2 - 78.2	36.7 - 43.0
No. 2 Diesel	417 - 670	10.2-30.1 (2.0) (1.0)	0.3 - 1.0	23.3 - 91.7	39.9 - 41.5
Methane	650 - 727	7 - 10 (0.99)	0.2 - 0.5 (0.19)	5 - 13	25.0
Methane	1063-1752	3.4-14.95 (0.72)	0.45-1.25	—	44.7
n-Heptane	636 - 707	1 - 2 (0.85)	0.2 - 0.6 (0.425)	12 - 24	37.8
Propane	560 - 727	1 - 10 (1.21)	0.2 - 0.7 (0.3)	7 - 27	38.2

Spadaccini, L and TeVelde, J. "Autoignition Characteristics of Aircraft-Type Fuels" NASA CR-159886, (1980). Combustion and Flame 46:283-300 (1982).

Taback, E.D., "The Autoignition Characteristics of JP-4 at High Temperature and Pressure", P&WA TDM-2284, 1971.



Name: Steven H. Izen  
Education: Ph.D., Mathematics  
Massachusetts Institute of Technology

Permanent Position: Associate Professor, Mathematics  
Case Western Reserve University

Host Organization: Space Experiments Division  
Colleague: Bhim S. Singh

Assignment:

During Professor Izen's summer faculty fellowship, he will conduct research in three areas which are closely related to his present primary research activities. These areas include: (1) tomography, (2) image reconstruction, and (3) application of wavelets. Specifically, Professor Izen will apply his expertise in these areas to develop techniques which will aid in the analysis of data obtained from current (and future) experiments which utilize optical diagnostic techniques. His research work will be applicable to various forms of interferometry and particle image velocimetry, both of which are currently being used in the Microgravity Fluids Branch. His contributions should lead to user-friendly methods which can be employed by a wide range of experimentalists in these areas.

---

### Partial Coherency in Forward Scattering Particle Image Velocimetry

The immediate objective of the Forward Scattering Particle Image Velocimetry (FSPIV) experiment is to determine the three-dimensional velocity profile in a fluid. (The ultimate objective is to understand the physics of a thin film in a microgravity environment).

A fluid is seeded with small spherical particles. The fluid is illuminated and the movement of the particles is observed with a microscope. A particle's transverse position is tracked over time to give a velocity profile in two of three dimensions. The velocity information in the third dimension is obtained by an analysis of the particle's image as this image will depend on its position with respect to optimal focus for the microscope system.

This image analysis problem is an inverse problem: The recovery of the position with respect to optimal focus from the image. The work performed this summer was the analysis of this inverse problem.

In order to attack the inverse problem, it was necessary to obtain a better understanding of the corresponding forward problem. The present model used in the computer software assumes coherent illumination, although the experiment itself uses partially coherent illumination.

This summer's contribution was to enhance the model to incorporate partial coherence. As a consequence of the techniques used to accomplish that, it became apparent how to extend the model to handle non-planar source illumination.

Because the scattering particles' size is on the same order of magnitude as the wavelength of the illuminating light, geometric optics cannot be used to compute the scattering. Instead, the analytic solution to the vector Helmholtz equation must be used. The current model is based on Mie theory, which is applicable to spherical scattering from a coherent plane wave source. In order to work with partially coherent light, one needs to compute the scattering due to point sources.

A decomposition of the incident plane wave into a superposition of appropriate point illuminated by such a point source was calculated. By taking a suitable double integral of this expression over the incident plane, one could compute the image of a partially coherently illuminated particle. Alternatively, by taking an integral over the illuminating plane with the addition of a phase term, the scattering from more general incident illumination profiles could be computed.

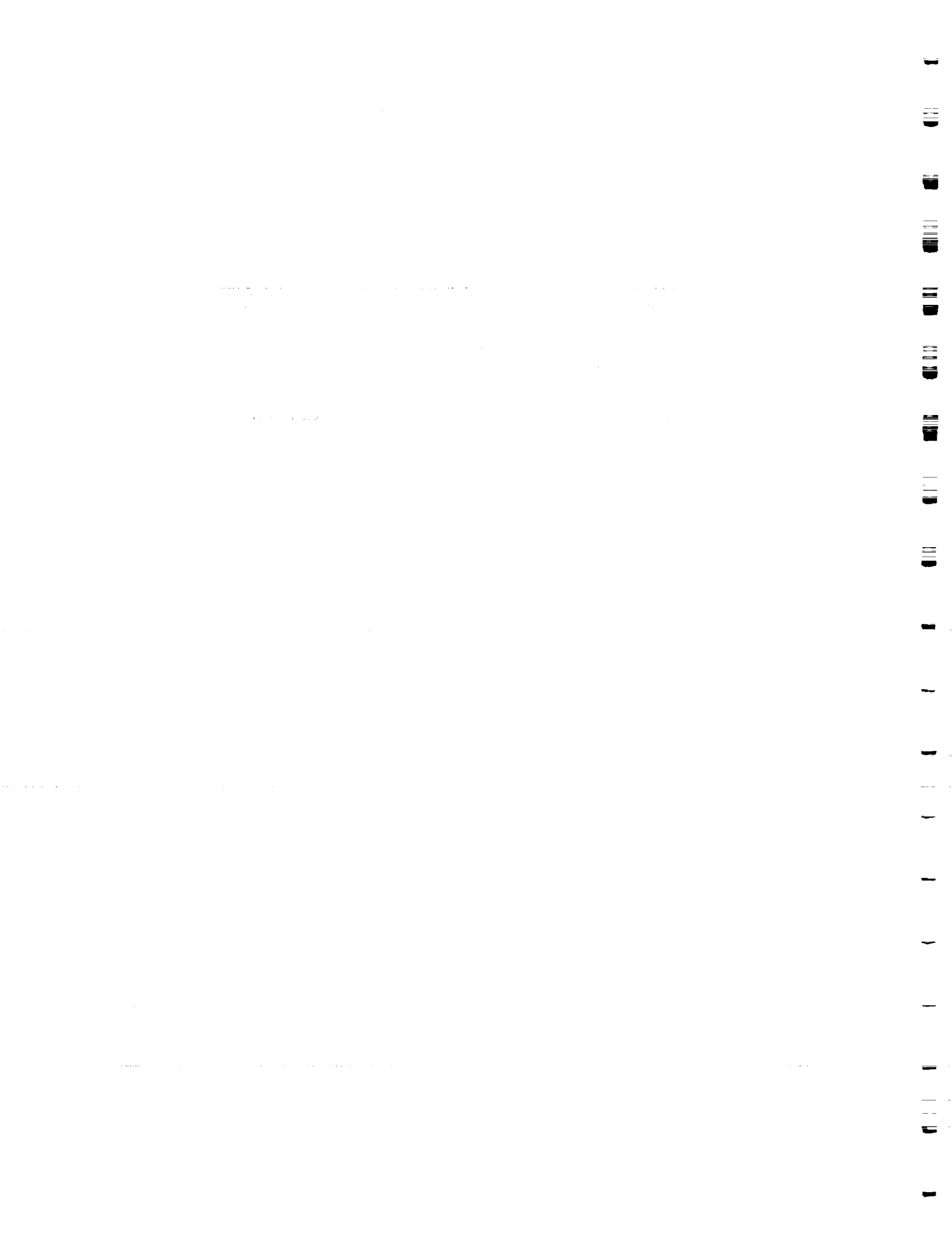

Name: Osama M. Jadaan  
Education: Ph.D., Engineering Mechanics  
Pennsylvania State University

Permanent Position: Associate Professor, General Engineering  
University of Wisconsin-Platteville

Host Organization: Structures Division  
Colleague: Noel N. Nemeth

Assignment:

Continue to enhance the CARES/CREEP program for creep of advanced ceramics, including benchmark problems and program debugging. Work on developing a users manual for CARES/CREEP. Investigate probabilistic creep mode and formulate approaches for estimating statistical based creep parameters. Coordinate this work with experimental verification in the LeRC ceramics fracture laboratory.

---

### **Probabilistic Creep Design Methodology for Ceramics**

Lewis personnel have developed the CARES/LIFE program for structural ceramic reliability analysis for use in high-temperature aerospace/terrestrial power and propulsion applications. Present capabilities of this program include the fast-fracture and subcritical crack growth failure mechanisms. These failure modes are typically active at high loadings and low to intermediate temperatures. However, the long design lives needed for APU's (Auxiliary Power Units) and aero-derivative turbine systems with hot-section ceramic components means that ceramic part's integrity is controlled by creep. As the next logical step in the development of ceramics life prediction software, a multiaxial creep failure prediction methodology would complement previous activities and be a major contributor in on-going national ceramic heat engine programs.

Currently, extremely limited multiaxial creep data for ceramic materials to be used in the design of ceramic structural components are available. The ceramic literature does not contain information on how to analyze and design components subjected to multiaxial creep load conditions. In addition, it is not even known whether creep analysis and design should be based on deterministic or probabilistic approaches. Finally, there is a need to develop a verifiable, integrated design code to be used as a postprocessor with commercially available finite element packages so that the lifetime of structural components subjected to creep rupture conditions can be predicted.

Therefore, the aim of this Summers research was to accomplish two objectives. These objectives are: 1) assessment of probabilistic creep design methodology for ceramics, and 2) Incorporating these developments into an enhanced version of the currently available NASA integrated design creep code CARES/CREEP.

The applicability of utilizing creep probabilistic approaches to predict the reliability (failure probability) of ceramic components was studied. Currently, most ceramic researchers utilize deterministic approaches to describe creep deformation (hence, creep parameters), and to even predict creep rupture lives. Ceramic creep deformation, and thus creep material parameters, display less stochastic and more deterministic behavior compared to fast fracture and slow crack growth failure data. An indication of that is the absence of the so called "size effect", which is a characteristic of the probabilistic behavior of brittle fracture in ceramics.

However, some ceramics tend to display significant scatter in the creep rupture data. The theoretical development for stochastically predicting the creep life of ceramic structures is not well developed and still is in its infancy. One theory is based on the premise that both SCG and creep failure modes are acting simultaneously. A second theory combines continuum damage mechanics and the Weibull distribution, assuming that the failure processes for SCG and creep are separable. Yet another theory is based on embedding the Monkman-grant creep rupture criterion into the Weibull distribution. All three approaches were investigated. Results indicate that the last two approaches have potential for determining the reliability of structural components subjected to creep rupture loading. Hence, these models will be further investigated to determine their capability in predicting the reliability of components subjected to complex multiaxial creep loading.

Name: San-Mou Jeng  
Education: Ph.D., Mechanical Engineering  
Pennsylvania State University

Permanent Position: Associate Professor, Aerospace Engineering  
University of Cincinnati

Host Organization: Propulsion Systems Division  
Colleague: Robert R. Tacina

Assignment:

This assignment will be an experimental effort to measure the flow field from a lean direct injection fuel-air subsystem. The fuel-air subsystem will consist of a fuel injector and an axial or radial air swirler. The emphasis will be on the radial air swirler with the axial swirler used as a baseline. The hardware will be designed and fabricated under another contract with General Electric. The measurements will consist of mapping the air and fuel flow fields under isothermal conditions and then if time permits measurements will be taken in a reacting environment. Accompanying student: Anthony B. Opalski.

---

### Design and Experiment of Radial Swirler

Swirlers are commonly used in gas turbine combustors in order to control the fuel/air mixing process and to improve flame stabilization. Different axial swirlers have been studied in the High Speed Research (HSR) program at NASA Lewis Research Center with applications to fuel lean burning primary zones in order to lower NO(x) emissions. Correlations between the axial swirler design and the NO(x) emission index have been successfully established during the HSR program and advanced axial swirlers have been tested at NASA LeRC on different HSR combustor concepts.. Combustors using Lean Direct Fuel Injection (LDI) have been proved to produce stable combustion with low emissions. In order to advance the LDI concept to the full combustor rig test and to take advantage of the newer and simpler manufacturing techniques, the radial swirlers fabricated by platelets are considered in the next phase study of HSR.

The goals of the summer research are to establish simple methods to guide the design of radial swirlers and to develop rapid turn-around experiments which can verify swirler performance for low NO(x) emissions. Previous experimental results have shown that the swirler number, a non-dimensioned properties based on the ratio of flux of the angular momentum and the axial thrust, produced by geometrically similar swirl generators can be used to establish the criterion of swirling jets. It was found that the pressure drop of the radial swirlers, which controls the fuel/air ratio of individual swirler of whole combustor, can be estimated based upon the previous studies conducted on cyclone generators and simplex fuel nozzles. For example, a simple equation, based on the dimensions shown in figure 1 and the swirler operating conditions has been successfully derived.

Several different approaches to establish a prototype experimental facility to study the aerodynamics of the radial swirlers have been explored. The concept of using water stimulant was adopted and demonstrated. The advantages to use a water stimulant are: (1) the experimental apparatus can be established with little effort and the tests can be conducted with minimum costs, (2) the velocity and time scale of water flow are 1/10 to 1/100 of those of air flow (the same Reynolds number, depending on the air pressure and temperature), which will lead to more accurate measurements, (3) water can be easily visualized with either dye or particles additions, and this makes the flow visualizations an excellent tool to identify the flow regions of swirlers and can lead to the findings of new flow physics.

To demonstrate the use of the water stimulant, a prototype swirler was build and tested. The pressure drop of the considered swirler cup is shown in figure 2. It was found that the pressure drop across a radial swirler is a weak function of the Reynolds number and is very sensitive to the swirler configurations. The flow visualization was conducted by either injecting dye mixed

with milk or particles (vegetable oil or soda). The vortex structures and recirculating zones were clearly identified at three swirler configurations under a wide range of operating conditions. At low Reynolds numbers, recirculating zones and fuel injection flows were found oscillatory, and the oscillatory frequency and flow velocity were apparently related. However mathematical relationship have not yet been established. At high Reynolds numbers, oscillatory fluid motions can not be detected due to the low framing rate of camera used in the experiments..

The use of water stimulant to study the swirler aerodynamics has proved very successful, although the measurements of detailed velocity distribution were not attempted due to the availability of equipment. It is concluded that the simulations based on water fluid can be used to screen the swirler cup design before the hot fired tests of the HSR and AST programs. In addition, water simulations can also provide other critical design information for advanced combustors. A simple water simulation based on the combustor sector can provide the flow distribution to different swirler cups, and the interactions among swirlers.

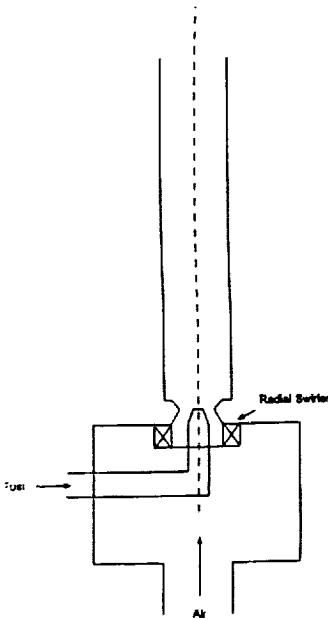

Figure 1. Radial Swirler

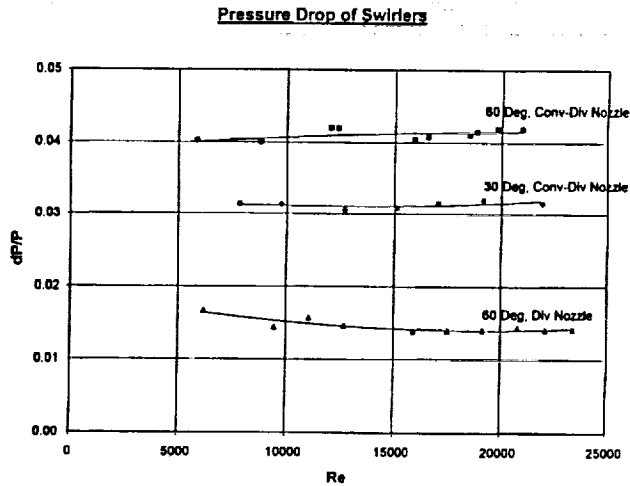

Figure 2. Pressure Drop vs. Reynolds Number

Education: Anthony B. Opalski  
University of Cincinnati

Permanent Postition: Student  
University of Cincinnati

Host Organization: Propulsion Systems Division  
Colleague: Robert R. Tacina

Assignment:

Accompanying student under the direction of Professor San-Mou Jeng.

---

In gas turbine combustors, swirlers are commonly used in order to improve and control the fuel/air mixing process, flame stability, emissions, and combustion efficiency. Until recently, though, most applications involved the axial type swirler only. Recent research involving radial swirlers used alone and in conjunction with the axial type has shown significant promise in achieving the goals set forth in the High Speed Research (HSR) and Advance Subsonic Transport (AST) programs at NASA Lewis Research Center. Two types of combustor concepts proposed utilizing these designs include the Lean Direct Fuel Injection (LDI) and the Lean, Pre-vaporized, Premixed (LPP) combustor. Both are being considered for future low NO(x) engines. These combustors, however, are highly susceptible to acoustic instabilities due to feedback between pressure fluctuations and combustion, causing damaging mechanical vibrations of the system, as well as degrading emissions characteristics and combustion efficiency. In such a lean flame, blowout can also readily occur. Thus it is apparent that significant effort must continue to be directed towards furthering our understanding of the flow physics and coupling (between heat release and pressure fluctuations) associated with these novel combustor concepts.

With the above in mind, the goals of my summer program as an accompanying student were two-fold. First, I was to assist Kevin Breisacher in his work involving an LPP combustor built for use as a full engine sector ignitor. Specifically, I was to advance the knowledge base concerning why low frequency axial acoustic modes were being excited during high temperature hot fired testing. Second, I was to assist my advisor, San-Mou Jeng, along with his mentor, Robert Tacina, in their work involving LDI. Here, I was to perform actual data collection to establish a database to verify that computational results obtained to date at NASA matched the actual experimental findings.

Reviewing first my LPP work, it is clear that this instability could not be attributed solely to one cause. With combustion chamber acoustics becoming a problem when the coupling between pressure and heat release fluctuations exceeds the chamber damping and wall transmission losses (hence, an amplification of acoustic energy), the specific factors affecting these fluctuations must be determined. These include: (1) fluctuations in the fuel delivery system (own dynamics or coupled with chamber pressure), (2) variations in atomization and vaporization of the fuel and in fuel/air mixing, (3) variations in chemical kinetic reaction rates, and (4) combustor geometry. My task began with item (3).

Based on Kevin's prior findings, computed ignition (induction) times did not agree with the experimental fluctuations observed. These computational results were obtained using LSENS, a NASA code utilized for determining reaction chemical kinetics. In this code, propane was used as the fuel due to its widely published reaction mechanism scheme. However, it was suspected that this would produce a low induction time, and hence a different heat release rate than that produced using Jet A propellant as the fuel. Thus after learning the basics of LSENS, I obtained recent mechanism schemes for Jet A propellant and began to re-run all of the previous

propane test cases. This involved varying inlet temperature to the combustor, fuel/air ratios, and chamber pressures over a wide enough range of values to compare with the actual hot fired tests. Following my completion of this, I next had to learn to use TECPLOT ver. 6 in order to display the results in a more user friendly way. Then, induction times were visually determined and the results compared with the experimental data. Here it was found that the new computations produced unexpected results, leading us to believe that an improper reaction mechanism scheme was chosen. Using several other schemes obtained from outside channels, again unexpected results were obtained. This forced us to move onto analyzing the next factor.

Here, we combined factors (1) and (4) above into a single task. I was to model the actual fuel delivery system and injector array leading into the radial swirler area and determine the frequency response of the combustor operating under oscillatory input functions. Following an extensive literature review, a program obtained from COSMIC known as FLAPR2 was employed. This program accomplished a complete analysis of the above mentioned system with minor input required. However, due to the unavailability of the plotting program associated with this FORTRAN code, significant modifications of the main subroutines were required. A lack of time remaining at the center prevented the completion of this task. So, though the problem associated with this combustor has remained unsolved in the ideal sense of the word, the extensive analyses performed this summer have greatly assisted Kevin in his understanding of the flow dynamics of the system and significantly reduced the number of variables needed for future analysis of the same topic.

Reviewing the LDI work, following the manufacture of a scale model injector with various swirler angles and inter-changable nozzle designs, high flow rate tests were conducted in order to compare CFD results with that which would be obtained in a real combustor operating under hostile conditions. Water was used in place of air in order to achieve similar Reynold's numbers between flows without requiring the expenses associated with high airflow rate handling problems. This use of water greatly assisted the task of flow visualization which easily determined regions of re-circulation and flow separation associated with fluctuating fuel system flows. Results comparable to those obtained with the NASA code were obtained for several of the combustor configurations only, given a relative margin of error associated with the experimental setup. There was significant disagreement between a majority of the cases when considering total pressure drops across the swirler. This could be attributed mainly to the conditions immediately downstream of the combustor nozzle exit, in which an expansion occurs for the cfd code and does not occur or the experiment. Further studies would again be necessary to obtain empirical relations comparing the two cases. But once again advances have been made in which factors associated with this combustor concept can be ruled out as significant contributors to acoustic instabilities during future studies.

Further information regarding the tasks accomplished during my period of work with the LDI can be found by reviewing the summary paper submitted by my faculty advisor, Dr. San-Mou Jeng.



Name: Andrea L. Johnson  
Education: J. D., Telecommunications  
Harvard Law School

Permanent Position: Associate Professor, Law School  
California Western School of Law

Host Organization: Computer Services Division  
Colleague: Fredric N. Goldberg

**Assignment:**

Professor Johnson will be tasked to work with the staff of the Telecommunications and Networking Branch to help facilitate our providing a wide variety of services to the extended Lewis community. In this role she will do applied research into the impact, constraints, and opportunities that are inherent in the new telecommunication act. Two very specific areas of research will entail (1) the processes and procedures that Lewis and the entire NASA community should follow in our efforts in network consolidation, and (2) the legal and organizational process and procedures for Lewis to follow in advancing the POSTN concept of a unified Ohio networking strategy.

---

**PROBLEM:**

How to develop a multidisciplinary curriculum for grades 7-12 math and science teachers, and for CSD professional staff that does not presuppose prior knowledge or instruction in multiple subjects.

**GOALS:**

Establish a paradigm for integrated applied math and science curriculum that would be adaptable to an electronic format. The curriculum is to be designed to foster an interest in basic aeronautics and high performance network computing that will satisfy state and national standards in K-12.

Develop a curriculum for professional staff development on relevant legal issues affecting high performance computing and networking.

Provide critical link between basic legal, math and science principles and their and practical applications and problems.

**RESEARCH & SOLUTION:**

Paradigm developed involved four stages:

- 1) Modular approach to integrated curriculum which includes a fact pattern and series of tasks that reflect the principles taught. The tasks required resolution of applied problem solving involving multiple variables.
- 2) Tutorials to teach the basic concepts and principles. Tutorials focused on review and retention of substantive materials through a variety of interactive exercises.
- 3) Visual representations via role playing and simulations showing the consequence of errors in computing, converting and correlating mathematical and scientific formulas

- 4) Mathematical, scientific or legal problems, broken down into stages with hint and help tools, and then applied to resolve the problem.

**ACTIVITIES:**

- 1) Professional staff lectures for engineers, technicians and administrators on:
  - a) the legal and regulatory impact of the Telecommunications Act of 1996 as it relates to deployment of technology and negotiating contracts for high performance technology infrastructure.
  - b) computer network security issues in light of federal and state statutes governing computer fraud and abuse.
- 2) Lectures to middle and high school teachers and students on :
  - a) use of technology in the classroom to enhance understanding;
  - b) CD-ROM development and use; and
  - c) how to convert lesson plans to electronic format.

Name: Roger H. Johnson  
Education: Ph.D., Bioengineering  
University of Washington

Permanent Position: Assistant Professor, Biomedical Engineering and Radiology  
Ohio State University

Host Organization: Structures Division  
Colleague: George Y. Baaklini

**Assignment:**

Professor Johnson is expected to assist NASA Lewis in the x-ray tomography science and related imaging, algorithms, instrumentation, and data acquisition. Specifically, Professor Johnson will help extend our in-house capabilities to three-dimensional cone beam tomography, 3-D image reconstruction, and 3-D volume rendering. Image processing and image enhancement are also an integral part of this assignment. These improvements and extended capabilities will help Lewis in advancing the ceramic and composite management technology development programs such as ATTAP, HITEMP, and HSR.

---

**High-resolution Volumetric X-ray Imaging of Advanced Composites**

Our research effort has been directed toward the application of high-resolution x-ray imaging to understand the three-dimensional microstructure of advanced composite materials. Already available at NASA LeRC was a high-resolution, digital x-ray imaging system, called the SmartScan and manufactured by Scientific Measurement Systems. As manufactured, this system has the capability to perform two-dimensional, fanbeam microtomography (microCT, or very high-resolution CAT scanning). In this imaging mode, a plane through the object is illuminated by a collimated beam of x-rays and one-dimensional projections are acquired at a plurality of source positions surrounding the object. Data sets acquired using this geometry allow the reconstruction of selected image planes through the object. If a more complete appreciation of the microstructure is to be gained from three-dimensional information, a number of reconstructed image planes may be "stacked" in software.

Recently, a new method of tomographic imaging has been made possible by the emergence of a class of algorithms for conebeam tomography. In this imaging mode, a set of two dimensional transmitted x-ray projections are acquired at a number of positions surrounding the object, facilitating the direct reconstruction of a 3D object volume. Conebeam tomography is the most dose-efficient technique for image reconstruction, since the beam is not collimated at all, and a large number of "slices", or image planes through the object, may be acquired simultaneously during a single source rotation. In addition, the problem of inferior axial resolution (interslice spacing) compared to the in-plane resolution of fanbeam methods is overcome with the direct volumetric approach.

Our goal was to extend the capabilities of the NDE group in the Structural Integrity Branch to include direct 3D conebeam microtomography. I have previously applied an implementation of the Feldkamp conebeam reconstruction algorithm to biomedical problems, such as imaging bone microstructure and the guinea pig cochlea, and the acquisition of patient image volumes for 3D radiation treatment planning. As a starting point for a collaborative effort in 3D tomographic imaging, our task this summer was to port the necessary programs onto the local SPARCstation cluster at LeRC and modify them to accommodate data acquired using the SmartScan system.

Important accomplishments include 1) Successfully porting the code, which had previously been run on SGI and HP UNIX workstations, onto the local UNIX cluster and compiling executables. 2) Verifying the integrity and utility of the programs by generating simulated projections of mathematical phantoms. Projections calculated using a variety of source object-detector geometries were reconstructed using a number of preprocessing and filtering algorithms. 3) Adaptation of the data acquisition protocols for the SmartScan system to produce data sets suitable for reconstruction with the conebeam codes. This process entailed a substantial learning curve to precisely understand and learn to manipulate the system's geometry appropriately. While routine operation of the device is accomplished through turnkey scripts, conebeam data had to be acquired in a manual mode. 4) Acquisition of data sets from both well-characterized standard objects and

unknown, real structures including advanced composite material tensile coupons. 5) Reconstruction of images from the acquired data sets using the Feldkamp conebeam algorithm. 6) Investigation of software packages to facilitate visualization and understanding of the 3D image data.

Future plans include optimization of the data acquisition and image reconstruction parameters to obtain improved spatial and contrast resolution. X-ray source characteristics, system geometry, and specific parameters in the reconstruction algorithms will have to be fine tuned to accommodate the wide variety of composite materials specimens encountered. We intend to identify and implement appropriate data visualization tools in order to apply volumetric imaging to improve our understanding of composite materials process development and characterization of failure mechanisms.

Name: Kenneth M. Jones  
Education: Ph.D., Aerospace Engineering  
North Carolina State University

Permanent Position: Assistant Professor, Mechanical Engineering  
North Carolina A&T State University

Host Organization: Propulsion Systems Division  
Colleague: Charles J. Trefny

**Assignment:**

Lewis is currently involved in a cooperative program with Aerojet, Lockheed-Martin, and the USAF to develop an RBCC engine known as the "strutjet." Free-jet tests of a storable-fuel version of the strutjet are scheduled to commence in June of 1996 at the NASA Lewis Plum Brook Station Hypersonic Tunnel Facility (HTF). The summer faculty fellow will help define and implement an improved RBCC cycle analysis method. Accurate cycle analysis is required for trajectory optimization which allows the full potential of the RBCC concept to be realized. Recent data from inlet and combustor component tests is now available, as well as data from an ongoing CFD effort. With some innovation, this information should enable modeling of the complex mixing, combustion, and diffusion processes which occur simultaneously in the strutjet engine.

---

## Performance Analysis for RBCC "Strut-Jet" Engine

### Introduction

Hypersonic propulsion systems are gaining interest with the concept of single-stage to orbit vehicles. Such propulsion systems must operate efficiently throughout the flight regime from takeoff to hypersonic cruise. In order to accomplish this, combined cycle engines are being studied. Since different propulsion cycles operate more efficiently at different flight conditions; the integration of several propulsion cycles into a single system could produce a very efficient engine. One such system being developed at Lewis is the Rocket Based Combined Cycle Engine (RBCC). This engine integrates a high specific impulse low thrust-to-weight air breathing engine with a low specific impulse high thrust-to-weight rocket. From takeoff to Mach 2.5 the engine operates as an air-augmented rocket. At Mach 2.5 the rockets are turned off and the engine is transitioned to a dual-mode ramjet. Beyond Mach 8 the rocket would be turned back on.

The RBCC concept under development at Lewis is the "strut-jet". This engine contains two struts in the inlet to provide compression. The struts divide the flow into three separate flow paths. The rockets are embedded in the base of the struts. The fuel injectors required for the ramjet mode are also housed in the struts. At present a demonstrator RBCC "strut-jet" is being tested at Mach 6 and 7 flight conditions in Lewis' Hypersonic Tunnel Facility.

### Assignment

Support "strut-jet" demonstrator test by using APL's Ramjet Performance Analysis Code (PJPA) to model engine's performance at Mach 6 and Mach 7 test conditions. This includes setting up the software, developing input data sets for the "strut-jet" geometry, inlet conditions and fuel properties as well as making production runs at test conditions.

### Results

1. Setup data files for "strut-jet" geometry, inlet conditions and combustion chemistry for JP10 and SiH4.
2. Ran a baseline fuel-off case to calculate the internal force of the engine. For the Mach 6 case RJPA calculated an internal force of -82.1974 Ibs compared to -82.1992 Ibs from CFD solution 2.

3. Worked with APL personnel to develop method to simulate combustion efficiency. The code was written to freeze portions of the fuel to simulate inefficient combustion. This does not work for the complex fuel compounds, such as JP10.
4. Conducted parametric study to determine sensitivity of engine performance to combustion efficiency. Results are shown in Figure 1.

### References

1. Pandolfin, P.P. and Friedman, M.A., *Instructions For Using Ramjet Performance Analysis (RJPA)*, AL-92-P175, June 1992.
2. DeBonis, J.R. and Yungster, S., *Rocket-Based Combined Cycle Engine Technology Development~Inlet CFD Validation and Application*, AIAA Paper 96-3145, July 1996.

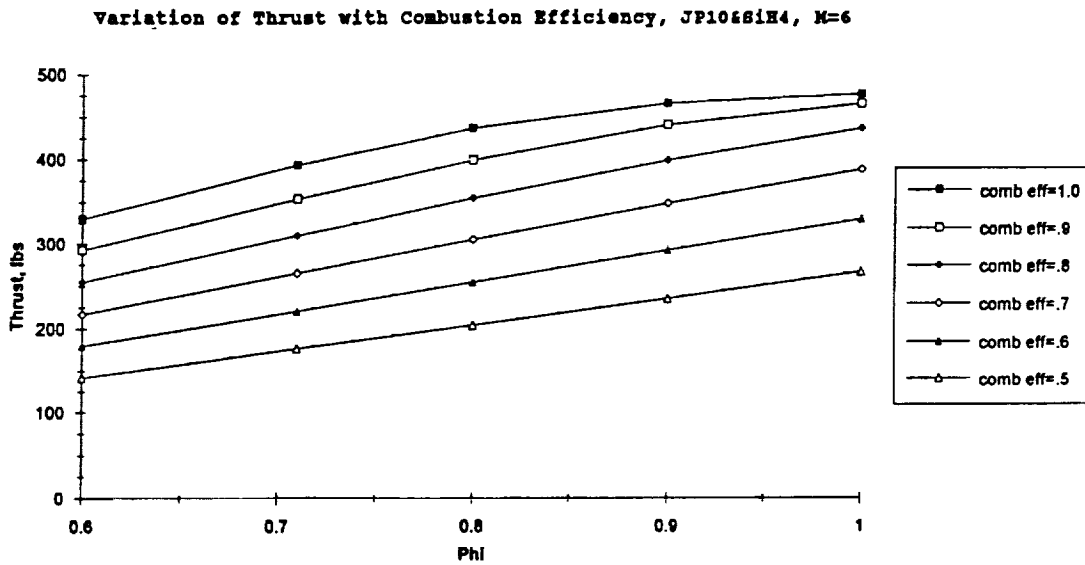

Name: Miron Kaufman  
Education: Ph.D., Physics  
Carnegie Mellon University

Permanent Position: Professor, Physics  
Cleveland State University

Host Organization: Lewis Research Academy  
Colleague: John Ferrante

Assignment:

The research assignment of Professor Kaufman will be to extend the previous theoretical examinations of the thermodynamic features of failure for bulk material using the equation of state of Ferrante et al. This extension will involve reformulating the previous studies for the more practical application of failure along interfaces which is the basis for fracture of materials. As part of this extension Professor Kaufman will investigate if the universal features found for bulk failure apply to this specific application.

---

### Statistical Mechanics Model of Solids with Defects

In collaboration with John Ferrante, I have extended the statistical model of mechanical failure. In our previous calculations we have used the realistic energy versus atomic distance formula developed by Ferrante and his collaborators. Furthermore, we have assumed the same strain  $\epsilon = (a - a_0)/a_0$  for all atoms. If the energy of a pair of atoms is larger than a threshold energy  $E_0$  the "spring" is assumed to fail. In the previous calculations we also have assumed that the "springs" fail independently of each other.

In the present work we improve the model by relaxing the limiting assumptions of "spring" failure independence and of uniform strain thus bringing the model closer to real solids. Simultaneously, to keep the model manageable, we assume the "springs" to obey the Hooke law.

The Hamiltonian is:

$$H = -E_c + \frac{K}{2a^2} \sum_{\langle i,j \rangle} [\bar{u} \cdot (\vec{r}_i - \vec{r}_j)]^2 + \frac{\lambda}{a^2} \sum_i (\vec{r}_i \times \bar{u})^2 \quad (1)$$

where  $E_c$  is the cohesion energy. The second contribution is the Hooke energy due to change in the distance between two atoms. The third term is shearing energy.  $\bar{u}$  is unit vector in the direction of the equilibrium bond. The partition function is:

$$Z = \sum_{conf} q^C Tr_{\{\bar{F}\}} \prod_{\langle i,j \rangle} w_{ij} \quad (2)$$

where the sum is over percolation configurations and the product is over the intact “springs”.

$w_{ij}$  is the Boltzmann weight:

$$w_{ij} = \exp[-(H_{ij} - E_0) / T] \quad (3)$$

$C$  is the number of clusters in a configuration and  $q$  is the “fugacity” controlling the number of clusters. The case  $q = 1$  corresponds to the absence of correlations between failing “springs”, i.e. random percolation. We now render the model more realistic by accounting for correlations: if  $q > 1$  larger clusters are favored, while if  $q < 1$  smaller clusters are favored.

To solve the model we employ a renormalization-group method. The basic idea of the renormalization-group approach to statistical mechanics is to perform the trace of degrees of freedom in the partition function, see eq. (2), in steps. After one step, we get an effective Hamiltonian  $H'$  which is a function of the original Hamiltonian  $H$ . After one more step we get  $H''$  which depends on  $H'$ . The process is continued until all degrees of freedom are summed up. Within the renormalization-group approach we get recursion equations for the thermodynamic fields: temperature, stress etc.. By following the flow of the recursion equations we can determine the phase diagram as different phases are governed by different fixed points of the recursion equations. The method also allows one to compute the free energy and thus to completely determine the thermodynamics of the system under study.

By using the Migdal-Kadanoff renormalization-group technique we find for a two-dimensional material two recursion equations involving the strength of the spring scaled by



temperature:  $K/T$  and a parameter proportional to the probability  $p$  for a “spring” to be intact:  $w = \exp[(E_c - E_0)/T] = p/(1-p)$ . Here  $E_c$  is the cohesive energy,  $E_0$  is the threshold energy where the “spring” fails, and  $p$  is the probability for a “spring” to be intact for  $K = 0$ . The recursion equations are:

$$w' = \frac{2w^2}{q\sqrt{\frac{K}{T\pi}} + 2\sqrt{2}w} + \frac{w^4}{\left(q\sqrt{\frac{K}{T\pi}} + 2\sqrt{2}w\right)^2} \quad (4)$$

$$\frac{K'}{T'} w' = \frac{K}{T} \left( \frac{w^2}{q\sqrt{\frac{K}{T\pi}} + 2\sqrt{2}w} + \frac{w^4}{\left(q\sqrt{\frac{K}{T\pi}} + 2\sqrt{2}w\right)^2} \right)$$

The free energy is computed by adding up contributions from each iteration step.

We plan to study these recursion equations and determine the phase diagram of the model. We also will compute the free energy and its derivatives such as the heat capacity. The recursion equations do exhibit an unstable fixed point at  $K/T = 0$ ,  $w = 2.34$  corresponding to the percolation threshold. We also plan to introduce in the model the stress. Finally it would be most interesting to examine this model with the realistic Ferrante at al energy replacing the Hooke energy.



Name: Sai C. Lau  
Education: Ph.D., Mechanical Engineering  
University of Minnesota

Permanent Position: Associate Professor, Mechanical Engineering  
Texas A&M University

Host Organization: Internal Fluid Mechanics Division  
Colleague: Steven A. Hippensteele

Assignment:

Professor Lau will plan and conduct liquid-crystal heat-transfer tests, reduce and analyze the data, and draft a paper on the multipass cooling model having film/bleed air geometries. As time permits, he will reduce, analyze, and report the liquid-crystal heat-transfer data from the High Reynolds Number Facility (ERB W5) on the film-cooled turbine-vane that was previously tested in the fall of 1994.

---

### Local Heat Transfer in Leading-Edge Cooling Channels in Turbine Blades

Various cooling methods have been developed over the years to keep turbine blade temperatures below critical levels and to achieve maximum heat removal while minimizing the coolant flow rate. One such method is to route cooling air through rib-roughened internal flow passages. The ribs interrupt boundary layer growth and cause flow separation and reattachment between consecutive ribs. They also increase the turbulent intensity in the flow and induce main flow-secondary flow mixing.

Transient experiments, using thermochromic liquid crystals, were conducted this summer in test cell SW6 in the Engine Research Building to study the heat transfer characteristics of turbulent flows in leading edge cooling channels in stator blades of gas turbines. The leading-edge cooling channels were modeled as two straight segmental channels (whose flow cross sections are two segments of a circle), and with transverse ribs on the curved wall of each channel. The ribs were square in cross section and the rib array had a pitch-to-height ratio of 10. Local heat transfer maps were obtained for two Reynolds numbers of about 20,000 and 45,000.

The test apparatus was an open flow loop. Hot air was forced through the flow loop with a centrifugal blower that was equipped with an electric heater. The hot air passed through a tee with a control valve, a calibrated orifice flow meter, a quick opening three-way valve, and then the test section. A second control valve was used to balance the pressure drops at the two exits of the three-way valve so that the flow rates were the same regardless of the set position of the valve at the beginning of an experiment.

Two segmental channels with inclusion angles of 165° and 180° were tested. Each of the two test sections consisted of two separate 9.53 cm long and 1.91 cm thick curved Delrin (E.I. Dupont®) segments joined together end to end with epoxy, and a flat wall made of clear acrylic. Transverse square ribs were machined on the inner surface of the curved wall of the test section. The rib pitch was equal to ten times the height of the ribs. The inner surface of the ribbed curved wall was sprayed with thin coats of flat black paint and thermochromic liquid crystals. These liquid crystals changed color at specific temperatures of about 38.0°C over a narrow temperature range of 0.6°C. They indicated isotherms of 38.0°C on the inner surface of the ribbed curved wall when they appeared yellow during an experiment. A video camera recorded the instantaneous locations of the yellow bands when the test section was heated as hot air was forced through the test section abruptly.

The local heat transfer coefficient along an isotherm indicated by the liquid crystals was determined using a finite-difference numerical method and a Microsoft EXCEL spreadsheet program. The solution took into consideration the measured variation of the local bulk mean air temperature with time, the actual inside diameter and outside diameter of the ribbed curved wall, and one-dimensional conduction in the radial direction in the ribbed curved wall. A guessed value of the heat transfer coefficient was used to determine the instantaneous one dimensional temperature distribution in the ribbed curved wall. The value was then systematically raised or lowered until the surface temperature reached 38.0°C at a time that was equal to the recorded time it took the liquid crystals to indicate a yellow band at a given location on the wall during an experiment. The final guessed heat transfer coefficient value was then the correct value.

The results of the experiments will be presented in a full length paper that will be submitted for publication in a major turbomachinery or heat transfer journal. The experimental results should enable a turbine designer to develop analytical or numerical models to optimize the rib configurations and the shapes of leading edge cooling channels in turbine blades for better thermal performance of gas turbine engines.

In addition to the completed turbine blade leading-edge channel heat transfer study, two additional experimental programs have been initiated. The first program is on the study of the effect of rotation on the heat transfer and film effectiveness distributions on turbine blades with film cooling. Most published film cooling heat transfer and film effectiveness data are for stationary test models. Coriolis and buoyancy forces, which are expected to significantly change the heat transfer and film effectiveness distributions on the surfaces downstream of film cooling holes, have not been considered. The second program is on the study of heat transfer distributions on the blades and the rotors of radial inflow turbines that are commonly used for propulsion of helicopters, military ground vehicles, and other systems that require compact power sources. The main component of the test apparatus for the second program will be a model of the rotor, the stator, and the volute of a radial inflow turbine. To accomplish the objectives of the two programs, innovative remote data acquisition techniques will be developed.

Name: Paul P. Lin  
Education: Ph.D., Mechanical Engineering and Applied Mechanics  
University of Rhode Island

Permanent Position: Associate Professor, Mechanical Engineering  
Cleveland State University

Host Organization: Aeropropulsion Analysis Office  
Colleague: Sasan C. Armand

Assignment:

(1) Develop methodology and computer program using Taguchi method for optimization and sensitivity studies of engineering problems. (2) Develop methodology and computer program using Artificial Intelligence method for optimization and sensitivity studies of engineering problems. (3) Document the methodology and programs in items (1) and (2) above. Present the methodology and programs to Mission Analysis Branch.

---

### **Robust System Parameter Design Using Taguchi Techniques and Neural Networks**

#### **Objective**

The main objective of this project was to develop a methodology for robust system parameter design. To verify the methodology, two engineering problems were investigated. The first problem has to do with the rotating disk design for a high-speed aircraft engine, whereas the second one is thermal system design for solar powered irrigation.

#### **Approach**

Taguchi's design of experiments (DOE) techniques were used to identify the significant factors and from which the global or nearly global optimum values can be found. In addition, one of artificial neural networks, called back propagation was used to learn the nonlinear mapping between input and output. In simulations problems were solved forward, that is, given a set of some parameter values, the output such as disk mass and minimum disk life are calculated. This is, indeed, the so-called analysis. However, in real design a designer always wishes to design the system parameters by specifying the system's performance such as mass and life. Thus, a useful mapping for design is to place the system's performance in the input domain and the system's parameters in the output domain.

#### **Major Accomplishment**

1. With the use of Taguchi techniques, significant factors or design variables can be identified, and the design region can then be reduced. More importantly, the designer will get to know how to tune the significant factors so as to obtain a more optimum design.
2. The employment of neural networks makes an instant design of a complicated problem possible.
3. The new system parameter design as a result of implementing the Taguchi techniques and neural networks shows 20 to 30 times improvement in increasing the minimum disk life compared to the designs resulting from running an optimization program.
4. A systematic robust design methodology has been developed, which provides a better way of finding the global optimum solutions without having to run time-consuming optimization program.
5. The developed design methodology will make concurrent design more possible when multiple disciplines are involved.

1. The first part of the document discusses the importance of maintaining accurate records of all transactions.

2. It is essential to ensure that all entries are supported by appropriate documentation.

3. Regular audits should be conducted to verify the accuracy of the records.

4. The second part of the document outlines the procedures for handling discrepancies.

5. Any errors identified during the audit process should be promptly investigated.

6. The findings of the audit should be reported to the appropriate authorities.

7. The third part of the document provides a detailed explanation of the accounting principles.

8. These principles are fundamental to the preparation of financial statements.

9. The fourth part of the document discusses the role of the auditor in the process.

10. The auditor's primary responsibility is to provide an independent opinion on the financial statements.

11. The fifth part of the document concludes with a summary of the key points.

12. It is hoped that this document will be helpful to all those involved in the accounting process.

13. The document is intended to provide a comprehensive overview of the subject.

14. The sixth part of the document discusses the importance of transparency in financial reporting.

15. Transparency is essential for building trust and confidence among stakeholders.

16. The seventh part of the document outlines the requirements for financial statements.

17. These requirements are designed to ensure the reliability and comparability of financial information.

18. The eighth part of the document discusses the role of the accounting profession.

19. The accounting profession plays a vital role in the economy and society.

Name: Yueh-Jaw Lin  
Education: Ph.D., Mechanical Engineering  
University of Illinois

Permanent Position: Associate Professor, Mechanical Engineering  
University of Akron

Host Organization: Structures Division  
Colleague: Ho-Jun Lee

Assignment:

Professor Lin will work towards the development of controller strategies for smart composite shell structures with embedded piezoelectric actuators and sensors. He will develop an admissible controller for the active displacement and vibration control of adaptive composite shells. The controller will use feedback from distributed sensors to regulate the electric voltage applied on piezoelectric actuators. Analytical models of the controller will be integrated and interfaced with existing in-house analytical models for piezoelectric composite shell structures. This work is an important step towards the development of adaptive casings for the blade tip clearance control in subsonic turbomachinery stages.

---

### **Vibration Control of Composite Shell Structures with Piezoelectric Sensors/Actuators**

In the past 12 weeks I have been working on a project entitled: "Vibration Control of Composite Structures with Piezoelectric Sensors/Actuators". My NASA colleagues are HoJun Lee and Dimitris A. Saravonos of the Structural Mechanics Branch at the Lewis Research Center.

Our goal of this project was to investigate the feasibility of reducing and/or eliminating undesirable vibrations/noises of turbine engine casing by using piezoelectric sensors and actuators through active control techniques. This is motivated by the fact that in turbine aircraft engine, the clearance between rotor blade tips and the engine casing is a critical factor in determining engine efficiency and longevity. Therefore, it is always desirable to keep the clearance to a minimum in order to maintain peak engine efficiency. This implies that any deformation of turbine engine casings may cause serious deterioration of the efficiency and life of the engines. To simulate the casing structures, the finite element mathematical model of a composite shell structure was formulated. This finite element model enables the comprehensive description of the dynamic behavior of the underlying structures when it is subjected to external disturbances such as impacts, forces, torques, etc. Dynamic analysis of the shell structure has been performed based on the formulated finite element model. The inputs which simulate different external disturbances include impulses, steps, sinusoidal, as well as random signals. It is found that deformations of the structure due to these disturbances are significant at times, especially when the shell structure is subjected to random interferences.

To reduce the deformation and vibrations due to external disturbances, several active control schemes such as PD, PID, Lead, Lag, and state feedback pole-placement techniques have been applied to the system. With careful tuning of the control parameters, a PI controller was adopted with a relatively high proportional gain. Further study on other control options shows that pole-placement state feedback control with five pairs of slightly offset complex conjugate poles provides the best results of vibration suppression and deformation reduction of the shell structure under study. By trying out a good number of cases, simulating a variety of external disturbances, the pole-placement method proves to be robust and provides a substantial increase of bandwidths and an improved damping.

Future research along the line will include ring structure composites as well as applying piezoceramic sensors and actuators.

1. The first part of the document discusses the importance of maintaining accurate records of all transactions and activities. It emphasizes that proper record-keeping is essential for ensuring transparency and accountability in financial reporting.

2. The second part of the document outlines the various methods and techniques used to collect and analyze data. It highlights the need for consistent and reliable data collection processes to ensure the validity of the results.

3. The third part of the document describes the different types of data that are collected and analyzed. It includes information on both quantitative and qualitative data, as well as the various sources from which the data is obtained.

4. The fourth part of the document discusses the various statistical methods and techniques used to analyze the data. It covers topics such as hypothesis testing, regression analysis, and correlation analysis, among others.

5. The fifth part of the document discusses the various ways in which the results of the analysis can be presented and communicated. It includes information on the use of tables, graphs, and charts, as well as the importance of clear and concise communication.



Name: James A. Lock  
Education: Ph.D., Physics  
Case Western Reserve University

Permanent Position: Professor, Physics  
Cleveland State University

Host Organization: Materials Division  
Colleague: Thomas K. Glasgow

Assignment:

- (1) Assist in the design of an anti-slosh optical system for correlated surface light scattering.
- (2) Analysis of cross-correlation optical systems for correlated bulk light scattering.
- (3) Derivation of formulas for multiple scattering corrections to correlated bulk light scattering.
- (4) Analysis of fiber optic systems for correlated surface and bulk light scattering. These topics represent either a continuation of the work Professor Lock did last year during his summer faculty fellowship in the Processing Science and Technology Branch or proposed research that the light scattering group in this branch is planning.

---

### Multiple Scattering Suppression in Photon Correlation Spectroscopy

During this Summer Faculty Fellowship in the Materials Division of the NASA Lewis Research Center, my project was the suppression of multiple scattering in cross-correlation photon correlation spectroscopy (PCS) applied to the study of small particles suspended in a liquid. PCS is the nonintrusive measuring technique of choice for determining the diffusion coefficients and particle sizes of suspensions, and for studying the properties of colloidal crystals and phase transitions in colloidal systems. When single scattering by the suspension particles dominates, the signature of the scattered light is simple to analyze. But when multiple scattering dominates, analysis of the scattered light signature becomes imprecise. Thus it is of importance to design instrumentation that suppresses the multiply scattered light signal so that concentrated suspensions may be analyzed with the same ease and accuracy that dilute suspensions are.

Current multiple scattering suppression instrumentation employs an Ar<sup>+</sup> laser in the multiline mode and two detectors equipped with absorption filters so that each detector records light of a different wavelength. The geometry that I examined on the other hand, employs a single wavelength laser and two adjacent fiber optic detectors. The basic idea behind the multiple scattering suppression for this geometry is that with suitable design parameters the single scattering spatial coherence length is larger than the separation between the two fibers while the multiple scattering spatial coherence length is smaller than the fiber separation. As a result, the single scattered light will be correlated while the double scattered light will not be correlated.

As a first step, I calculated the electric field and intensity cross-correlograms for single and double scattering. The evaluation of the double scattering cross-correlogram depended on the details of the incident laser beam and the field of view of the detectors. I modeled a focused Gaussian beam to be incident on a suspension in a cylindrical cell which was in turn enclosed in a larger index-matched cylindrical vat. I also modeled both narrow field of view and wide field of view detectors. The resulting multiple scattering suppression was found to be significantly larger for the wide field of view detectors because a wide field of view detector sees double scattering occurring over a larger region which produces a smaller spatial coherence area. The wide field of view detector can be realized by employing a monomode fiber at a wavelength below the monomode cutoff point.

The effects of the index matching cylindrical vat on the incident focused beam and the outgoing scattered light were also calculated. The vat causes the incident beam to focus astigmatically in the sample cell. The positions of the two focal lines and the diameter of the beam waist were calculated. In order to minimize the range of scattering angles recorded at the detectors, the detectors were considered to be at the paraxial focal point of the cylindrical vat. With this positioning, the range of scattering angles for both single scattering and double scattering was calculated and was found to be small. The effect of

the curvature of the vat surface on the single scattering spatial coherence length was also calculated. Parallel to the cylinder axis the coherence length decreased by only 6% and was still much larger than the fiber separation. But perpendicular to the cylinder axis it decreased by 33%. Thus each fiber overlaps two coherence areas side to side while being within the same coherence area top to bottom. While this reduces the signal to noise level somewhat, the signal is still robust enough to be easily detected. This instrumental geometry will thus be able to suppress multiple scattering to a large degree and extend the measurement range of cross-correlation PCS to dense suspensions.

Name: J. Adin Mann, Jr.  
Education: Ph.D. Physical Chemistry  
Iowa State University

Permanent Position: Professor, Chemical Engineering  
Case Western Reserve University

Host Organization: Materials Division  
Colleague: Thomas K. Glasgow

**Assignment:**

A set of studies of monolayers and multilayers of nCB liquid crystal molecules important in the liquid crystal display technology. Brewster angle microscopy and surface light scattering spectroscopy developed under contract with NASA Lewis and in collaboration with staff will be the principal tools for the experimental work. Observe the morphology of these monolayers along with their light scattering spectra and measure in detail the molecular tilt along with surface strain response which are expressed in terms of viscoelastic parameters. For the first time we expect to examine the liquid crystal surface anchoring problem from first principles experimentally. Observe the surface tension composition variation of liquid metals. Run experiments in a glove box that has been purged of oxygen and use certain cleaning procedures that will approach what can be done in ultra-high vacuum.

---

## Surface Laser Light Scattering Spectroscopy

### Introduction

The result of a number of years of research at CWRU joint with NASA Lewis has produced a number of new designs of compact instruments for recording subtle fluctuations at liquid/vapor and liquid/liquid interfaces of diverse types (surface light scattering spectroscopy (SLSS)). It useful to think of these fluctuations as a class of capillary waves. Of particular interest has been the surfaces of simple liquids, complex solutions of surface active materials, clean liquid metal surfaces, liquid metal surfaces with adsorbed layers, and complex melts of metal oxides at high temperatures. The spectrometers we have designed can operate in a low gravity environment and is non contact. The we have shown that the surface can be at elevated to temperature up to about 3000 Kelvin or more; black body radiation does not contribute to the signal. This measurement technique can be coupled with Brewster Angle Microscopy (BAM, a type of ellipsometry) to provide surface energy and other properties of adsorbed ultrathin films coherent with the morphology of the films. In addition volume phase viscosity can be estimated.

The surface fluctuations detected by these spectrometers are generated by tiny pressure pulses that are always found in liquids above zero Kelvin. The RMS amplitude is between 0.3nm and 1nm with a spectral range from a few hundred Hertz to very high frequencies above 1GHz. The spectrometers we have designed work between about 2KHz to about 50KHz and within this range is a rich set of phenomena to be explored both here on earth and under the low gravity of space.

### Experimental Projects

**Monolayers:** The purpose of this project is to correlate the morphology of monomolecular films as determined by surface pressure vs surface density and BAM with the capillary waves detected by SLSS. The trick has been to superpose the footprints (~1mm or smaller) of the BAM and SLSS laser beams. We accomplished the task of superposing the beams on exactly the same patch of monolayer spread on a specially designed Langmuir trough.

We have chosen to study monolayers of nCB (cyano-biphenyl molecules with a hydrocarbon tail of n carbon atoms) which is a class of liquid crystal molecules used in displays. The results are relevant to the understanding of the possible configurations these molecules have at an interface as well as the anchoring energy. The experiment was accomplished and data is being collected at this writing for publication. The technique will be applied to a series of polymer systems being studied at CWRU. A next step will be to attempt to use the same incident beam for both BAM and SLSS. It is possible to scan this system to observe gradients of structure in processes involving the Langmuir Blodgett technology being developed at CWRU.

**Volume Viscosity.** The theory and practice of SLSS show that both the surface tension and volume viscosity can be determined by a simple measurement with SLSS. This can be done with high temperature melts in principle. While we have shown that it is possible to make measurements over a large temperature, we need a body of data on systems of widely varying viscosity with essentially constant surface tension. Glycerol - water mixtures satisfy these conditions. The surface tension of water is 72 mN/m and glycerol is ~65 mN/m; the viscosity varies between 0.01 d-cm/sec and about 1000 d-cm/sec. The SLSS spectrum goes from being under damped to over damped in this range. This allows a very close check of both the theory and the function of the instrument. Data is being collected and analyzed for publication.

**Liquid Metals.** I expected to have a body of liquid metal data on mercury and gallium by this time. However, the Brookhaven Instruments correlator card, an essential part of the spectrometer, was not delivered in operating condition. The execution of this experiment is scheduled for early September. However, a theoretical study was carried out.

## THEORETICAL STUDIES

**Theory of surface fluctuations.** A substantial effort was put into preparing a paper on the theory of surface fluctuation spectra. The theory is formulated from first principles to include nonlinear response. This allows the analysis of coupling that appears as the surface amplitude to wavelength grows to unity. Special emphasis is put on the construction of the fundamental equations taking into account the principle result of surface thermodynamics of Hansen and Cahn; the phase rule must hold which means that two variables (e.g. volume per unit area and surface density of the solvent) can be eliminated. Simplification results when this principle is applied to the construction of the surface governing equations. This property is exploited in deriving a set of governing equations that includes also a new way to represent surface growth by adsorption. Emphasis was also focused on constructing constitutive equations for diverse applications that include next order nonlinear effects.

**Analysis software.** Programs for the analysis of SLSS were refined using windows technology and is the basis of the analysis of the auto correlation functions generated by the experimental projects. New programs were written to include the theory of surface viscoelastic properties of monolayers. Modeling calculations for oxide layers on liquid tin and now gallium nitride layers on liquid gallium. We hope to be in a position to do experimental work on these systems over the next year.

Name: Mohammad H. Naraghi  
 Education: Ph.D., Mechanical Engineering  
 University of Akron

Permanent Position: Professor, Mechanical Engineering  
 Manhattan College

Host Organization: Materials Division  
 Colleague: Thomas K. Glasgow

Assignment:

Dr. Naraghi will be working on code development for computation of radiation heat transfer in participating media with application in combustion and materials processes such as crystal growth and CVD. He will be fine tuning and extending the development of the methodology which was initiated during his tenure last summer.

---

### A Volume Radiation Model for Bridgman Crystal Growth Process with the Dome-Shaped Interface

In the previous works [1-3] it has been demonstrated that the radiative heat transfer plays an important role in crystal growth processes. The model for radiative heat transfer in Bridgman furnace only considers radiative exchange among surfaces [1], assuming the crystal is transparent. The objective of this work is to develop a volume radiative heat transfer model for the Bridgman crystal growth process.

The Discrete Exchange Factor (DEF) method has been used to model volume radiation heat transfer during the Bridgman crystal growth process. As shown in [4], the DEF method is very effective in analyzing combined radiative-convective heat transfer problems. The configuration of a typical Bridgman furnace is shown in Figure 1. In this setup, the ampoule, which encapsulates both the solid and melt, is made of an opaque material and the melt is also opaque. Therefore, the volumetric radiative heat transfer is only confined to the solid portion of the crystal which forms a cylindrical enclosure with a dome-shaped top and a flat bottom surface. The governing equation of heat conduction within the crystal is given by:

$$\nabla^2 \theta = \frac{N_r \tau_o}{(1 - \gamma)} \nabla \cdot q_r'' \quad (1)$$

where  $\theta = (T - T_c)/(T_h - T_c)$ ,  $\tau_o$  optical thickness,  $\gamma = T_c/T_h$  and  $N_r = n^2 \sigma T_h^3 / \tau_o k (1 - \gamma)$  radiation-conduction parameter. At the boundaries there is a balance between conduction and radiation as:

$$-N_r \nabla T = q_s'' \quad (2)$$

The divergence of radiative heat flux in equation (1) is given by:

$$\nabla \cdot q_r''(\mathbf{r}_i) = E_v(\mathbf{r}_i) - \int_S E_s(\mathbf{r}_j) \overline{DSV}(\mathbf{r}_j, \mathbf{r}_i) - \int_V E_v(\mathbf{r}_j) \overline{DVV}(\mathbf{r}_j, \mathbf{r}_i) \quad (3)$$

similarly, the radiative heat flux in equation (2) is given by:

$$q_s''(\mathbf{r}_i) = E_s(\mathbf{r}_i) - \int_S E_s(\mathbf{r}_j) \overline{DSS}(\mathbf{r}_j, \mathbf{r}_i) - \int_V E_v(\mathbf{r}_j) \overline{DVS}(\mathbf{r}_j, \mathbf{r}_i) \quad (4)$$

where the total exchange factors,  $\overline{DSS}$ ,  $\overline{DSV}$ ,  $\overline{DVS}$  and  $\overline{DVV}$ , are evaluated based on the formulations given in [5]. Extensive derivations were made to evaluate exchange factors between various surface and volume elements for a cylindrical system with dome-shaped top and the corresponding computer program was developed to solve the problem numerically. The program uses the same mesh that is generated by a finite element code (FIDAP). A typical mesh and the corresponding dimensionless temperature distribution within the crystal is shown in Figures 2a and 2b. The resulting divergence of heat flux for this condition is shown in Figure 2c which shows the maximum volumetric radiative heat transfer is at the centerline close to the upper and lower surfaces. The high flux area at the upper part of the crystal is due to the fact that the crystal temperature is highest at this region and it can see the cold surfaces while the crystal close to surface at this region is more exposed to the hot surfaces which are almost at the same temperature as the crystal.

## References

1. Kassemi, M., and Naraghi, M.H.N., "Combined Heat Transfer and Fluid Flow Analysis of Semi-Transparent Crystals in Low-G and 1-G Solidification," ASME publication HTD-Vol. 284, Transport Phenomena in Solidification, Editors: C. Beckermann et al., pp. 245-254, presented at the ASME Winter Annual Meeting, Chicago, Illinois, Nov. 13-18, 1994.
2. Kassemi, M., and Naraghi, M.H.N., "Radiative-Convective Interactions in a Solidification of Semitransparent Crystals," Proceedings of International Symposium on Radiative Heat Transfer, 1996 (in Press).
3. Kassemi, M., and Naraghi, M.H.N., "Application of Discrete Exchange Factor Method to Combined Heat Transfer Problems in Cylindrical Media," to be presented at the 1996 ASME Winter Annual Meeting.
4. Kassemi, M., and Naraghi, M.H.N., "Analysis of Radiation-Natural Convection Interactions in 1-G and Low-G Environments Using the Discrete Exchange Factor Method," International Journal of Heat and Mass Transfer, Vol. 36, No. 17, 1993.
5. Naraghi, M.H.N., and Kassemi, M., "Radiative Transfer in Rectangular Enclosures: A Discretized Exchange Factor Solution," Journal of Heat Transfer, Trans. ASME, Vol. 111, No. 4, pp. 1117-1119, 1989.

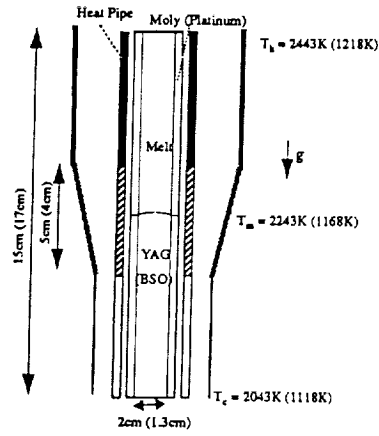

Fig. 1: Cross Sectional View of the Crucible in a Vertical Bridgman Furnace

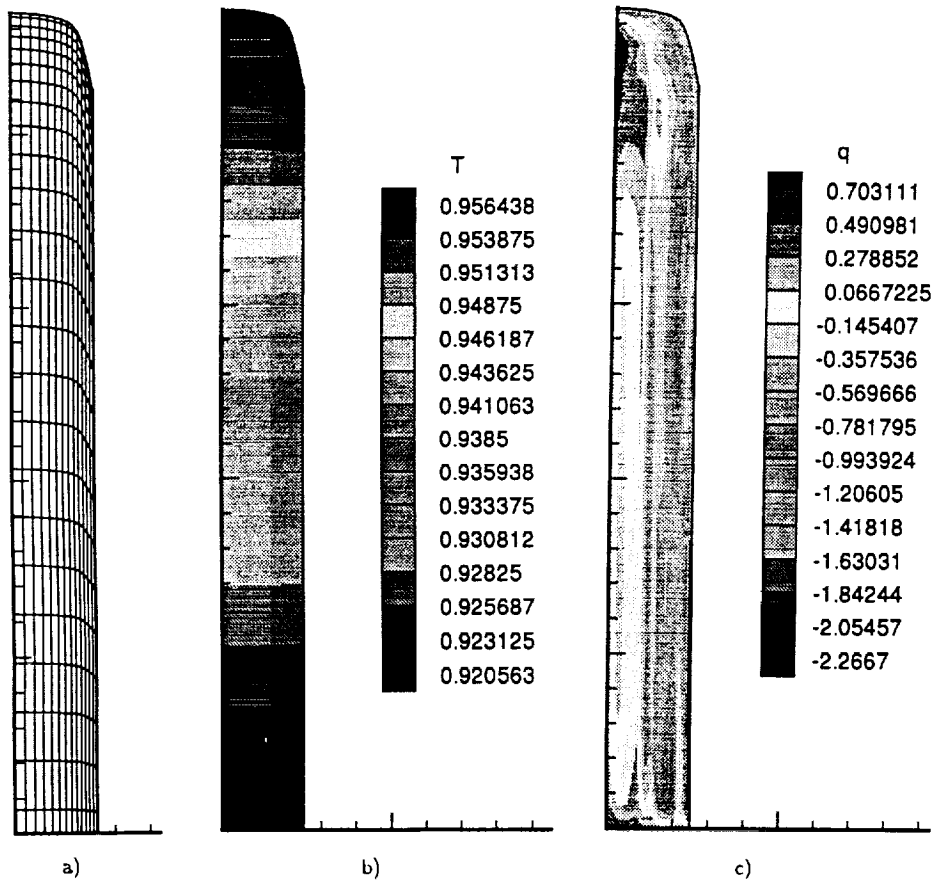

Fig. 2: a) Finite Element Mesh Used for the Radiative Heat Transfer model  
 b) Temperature Distribution Within the Crystal  
 c) Radiative Heat Flux Distribution

1. The first part of the document discusses the importance of maintaining accurate records of all transactions and activities. It emphasizes that this is crucial for ensuring transparency and accountability in the organization's operations.

2. The second part of the document outlines the various methods and tools used to collect and analyze data. It highlights the need for consistent data collection procedures and the use of advanced analytical techniques to derive meaningful insights from the data.

3. The third part of the document focuses on the role of technology in data management and analysis. It discusses how modern software solutions can streamline data collection, storage, and processing, thereby improving efficiency and accuracy.

4. The fourth part of the document addresses the challenges associated with data management, such as data quality, security, and privacy. It provides strategies to mitigate these risks and ensure that the data remains reliable and secure throughout its lifecycle.

5. The fifth part of the document concludes by summarizing the key findings and recommendations. It stresses the importance of ongoing monitoring and evaluation to ensure that the data management processes remain effective and aligned with the organization's goals.



Name: Masood Parang  
Education: Ph.D., Mechanical Engineering  
University of Oklahoma

Permanent Position: Professor, Mechanical Engineering  
University of Tennessee

Host Organization: Space Experiments Division  
Colleague: David F. Chao

Assignment:

Dr. Parang will continue to conduct research in two-phase flows in microgravity conditions that he began in 1995. During the 10-week duration of this research at LeRC, he will engage in (a) completing the review of the existing two-phase flow models using available published experimental data, (b) defining and suggesting the necessary analytical and experimental efforts required to help fill the gaps in the modeling of two phase flows under microgravity conditions, and submit a final report for his research effort.

---

### **Two-Phase Flow and Heat Transfer Under Microgravity Conditions**

During this research activity several objectives were accomplished. First, a literature review of two-phase flow mapping under normal gravity condition was completed and application and extension of flow maps based on mechanistic models to microgravity environment were considered. Next, a review of literature on the research activity over the last two decades in microgravity two-phase flow and heat transfer was completed. Finally, two-phase heat transfer models were reviewed and different approach for modeling heat transfer in microgravity two-phase slug and annular tube flows were considered.

The complexity in the physics of two-phase flow and heat transfer and wide range of activities in this area over the last forty years required a thorough and complete review before future research plans could be developed. This was accomplished successfully by completing this task in four parts: (a) adiabatic flows in normal gravity, (b) adiabatic flows in microgravity, (c) two-phase flows with heat transfer under gravity conditions, and (d) two-phase flow heat transfer under microgravity conditions. The Third Microgravity Fluid Physics Conference in Cleveland, a biannual event organized by the Microgravity Fluid Dynamics Discipline Working Group and hosted by NASA-LeRC, which was held this year from June 13 to 15 also provided a unique opportunity to meet other investigators in this area and provided a forum for very useful and up to date discussion of various ongoing research and projects with them.

An important result from this research was the development of a new map for the prediction of transition from bubbly to slug flow and from slug to annular flows. The recently available microgravity experimental data were used to map flow pattern transition in dimensionless variable forms based on a mechanistic model. The new map predicts flow transition for large range of flow rates in a more general and accurate way than those considered in the open microgravity literature. This effort has also pointed out the gaps in the experimental data which, when available, can be used to verify the new transition map in a more comprehensive fashion.

The recent investigations of heat transfer in two-component, two-phase tube flows remain very incomplete and the data too sparse for development of useful heat transfer models. Most investigators have attempted to extend available ground-based models to microgravity condition. The review of recent studies indicates that various potential benefits will result by further focusing research on flow patterns and their relation to heat transfer characteristics of the two-phase flows. In this research activity the ground work for the preparation of proposals for specific modeling effort, including numerical computation, and the definition of the necessary experiments to collect required data for validation of the model has been prepared. This effort is planned to be actively pursued for further development in the near future.

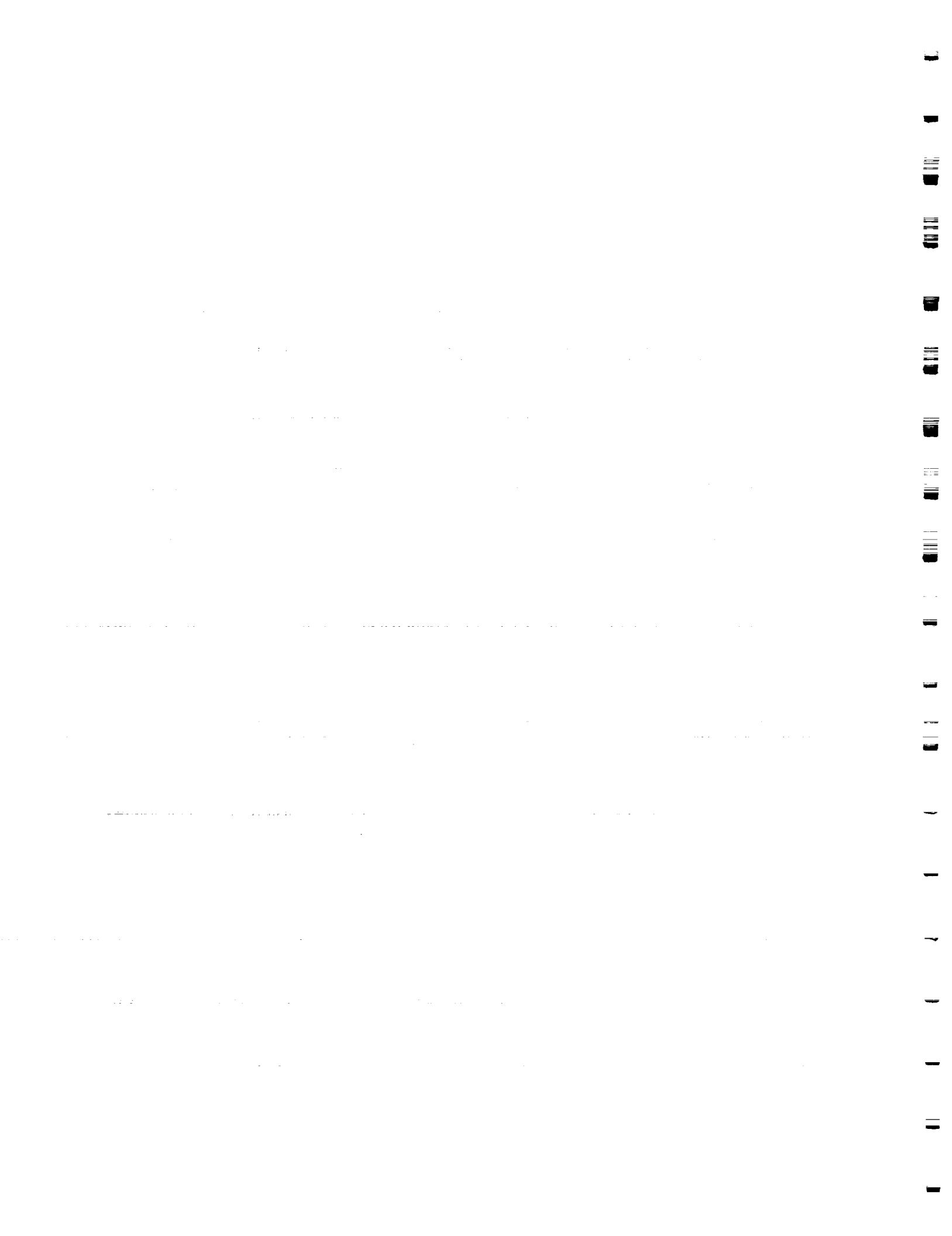

Name: Robert G. Parker  
Education: Ph.D., Mechanical Engineering  
University of California, Berkeley

Permanent Position: Assistant Professor, Mechanical Engineering  
Ohio State University

Host Organization: Propulsion Systems Division  
Colleague: Timothy L. Krantz

Assignment:

(1) Determine whether existing Lewis test rigs could be used to study the topic of vibration isolation for planetary gear systems. Develop a specification for rig modification and/or rig redesign so that needed experiments can be performed in the future. (2) Derive a discretized model for planetary gearsets to be used to study vibration isolation. The model should include the influences of mesh stiffness variation, elastic ring gear body vibration, gyroscopic effects, and small imperfections along with any other parameters the P.I. considers necessary. Accompanying Student: Aaron M. Dziech.

---

The purpose of my research this summer was to initiate collaborative work on the dynamics of planetary gears in helicopter transmissions. This is expected to be the initial phase of a continuing research program between Ohio State and NASA. Vibration and noise generated in the last stage planetary of helicopter transmissions is the primary source of cabin noise. With the overall goal of reducing cabin noise and increasing gear reliability, the intent of the project is to better understand the dynamics of the planetary gear as well as its coupling with the cabin.

My primary effort has been the development of an analytical model for the vibration of planetary gears. This is a lumped-parameter model that includes the gyroscopic effects associated with the rotations of the planet gears and carrier. Prior modeling has not included these gyroscopic effects, despite their potential impact on the response at high speeds. This model will permit investigation of other critical issues including gear mesh stiffness variations with either time or position, planet phasing to reduce vibration, and indexing of planets. These issues have proven critical in parallel axis gears, but they have not been thoroughly investigated for planetary gears. Derivation of the model is largely complete. Computational tools and experiments (see below) to benchmark the model have been identified.

A second task this summer has been discussions with Aaron Dziech, my accompanying OSU student on the program, regarding his research on vibration isolation techniques for the reduction of vibration energy transmitted from the helicopter transmission to the cabin. This is a second aspect of the cooperative OSU/NASA research. Aaron and I traveled with Tim Krantz, our NASA host, to Sikorsky Helicopter this summer to identify the important issues in industrial helicopter transmission vibration. This visit was highly beneficial for focusing the goals of the research. Tim will present ideas outlining our current experimental plans to Sikorsky on another visit this week. Sikorsky will likely support the helicopter transmission research through a research contract with OSU. This will provide a structure for the common involvement of government, industry, and university researchers.

Working at NASA Lewis for the summer allowed Aaron and I to identify experimental facilities at NASA that will be useful for the continuing efforts. The specialized test rigs available here will be used for at least two major experiments. Because of the proximity of NASA and Ohio State, these rigs will be essential tools during Aaron's Ph.D. research. Additional supporting experiments will be conducted simultaneously by Tim Krantz of NASA, so the overall project shows exceptional promise for synergistic cooperation.



Name: Aaron Dziech  
Education: Ohio State University  
Permanent Postion: Student  
Ohio State University  
Host Organozation: Propulsion Systems Division  
Colleague: Timothy L. Krantz  
Assignment:

Accompanying student under the direction of Professor Robeert G. Parker.

---

### **Future Research in Planetary Gearbox Vibration Isolation**

The primary objective of our summer Fellowship involved identification and investigation of potential areas for research in planetary gearbox dynamics. Utilizing the resources of both NASA and Ohio State, a substantial literature review has generated several topics of interest to this project. My efforts focused on vibration isolation of the ring gear as an effective means of reducing cabin noise and vibration in helicopters.

The first goal achieved this summer is an improved understanding of mechanical systems involving vibration isolation. A lumped parameter model (fig. 1) of a generalized system has provided insight into the factors governing the system response and isolator performance. Results of this analysis have generated ideas for future modeling improvements (fig. 2). More detailed modeling of the isolator and the driveline will improve the ability of analytical models to predict actual system dynamic response.

As a direct result of our experience at NASA, resources at the Lewis Research Center have been identified which have potential applications to this research project. Existing test facilities can be modified to obtain experimental measurements on a test gearbox. Experimental efforts will be a joint effort and are intended to provide data for comparison to analytical results.

Source

Isolator

Receiver

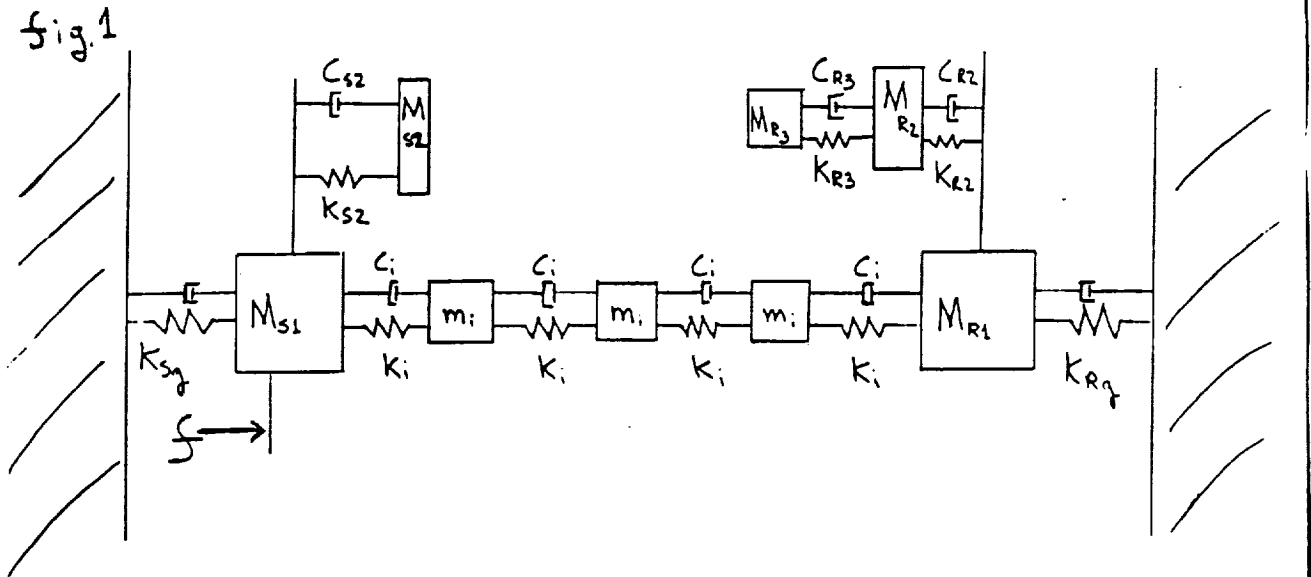

MULTIPLE DOF MODEL OF AN IDEALIZED ISOLATION SYSTEM

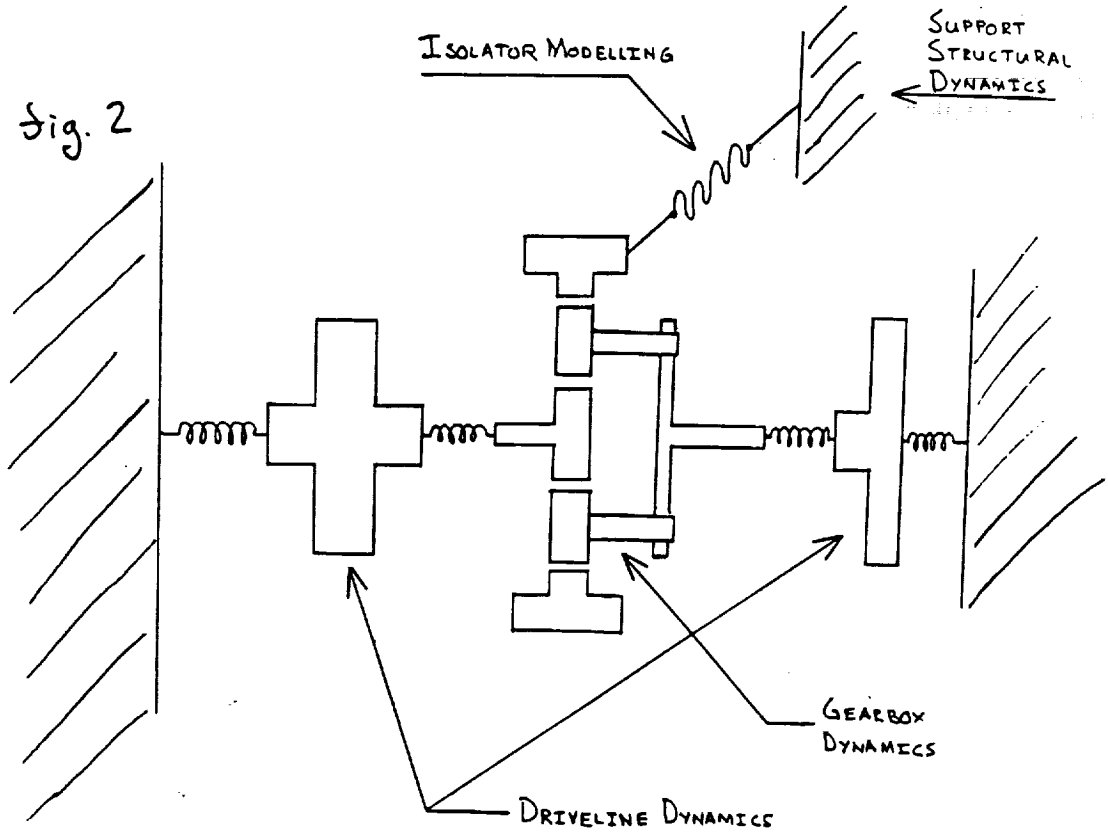

AREAS FOR POTENTIAL MODELLING IMPROVEMENT

Name: Helen K. Qammar  
Education: Ph.D., Chemical Engineering  
University of Virginia

Permanent Position: Assistant Professor, Chemical Engineering  
University of Akron

Host Organization: Instrumentation and Control Technology Division  
Colleague: Walter C. Merrill

Assignment:

Dr. Qammar will be responsible for creating a nonlinear time series analysis toolbox for chaotic dynamic systems. The software toolbox will be a MATLAB toolset for nonlinear filtering and chaotic analysis.

---

### **The Development of an Innovative Nonlinear Stall Detection Method for High Speed Compressors**

All commercial engine companies have on-going efforts to develop compressor stall warning or control schemes to enhance aero-engine performance. Last year we developed an innovative, nonlinear stall precursor identification method (CI method) which uses chaotic time series tools and consistently yields longer warning times than other methods. It detects nonlinear events 2-3000 rotor revolutions before stall in a region where the 'state-of-the-art'. Fourier-based, techniques do not detect changes. My research directive was to implement modifications to the CI method which would optimize the scheme and allow practical application as an on-line technique. The long range objectives of the proposed research are to enhance the existing CI method and to relate experimental observations from the method to changes in the physical flow phenomena in the compressor.

#### **Accomplishments:**

1. Developed a one year research plan in conjunction with NASA Lewis and General Electric Aircraft Engines to allow us to reach the long range objectives. Funding for this plan was obtained from Ohio Aerospace Institute, National Science Foundation, and the University of Akron. Key elements in the plan are the participation of international experts in compressor stall dynamics and CFD compressor models from NASA Lewis and MIT.
2. Presented results from our CI method at the International Gas Turbine Conference, Birmingham, UK. One outcome from this conference is the acquisition of a number of stall precursor data sets from both international and domestic aircraft companies. This acquisition will allow us to test the applicability of our method to a wide range of compressor configurations.





Name: Majid Rashidi  
Education: Ph.D., Mechanical Engineering  
Case Western Reserve University

Permanent Position: Associate Professor, Mechanical Engineering  
Cleveland State University

Host Organization: Aeropropulsion Analysis Office  
Colleague: Sasan C. Armand

Assignment:

(1) Develop methodology for predicting the transient events, such as landing loads, for the aircraft engine rotors. The methodology should use either mode-displacement method or mode-acceleration method. (2) Implement the methodology in the existing computer program used at LeRC, FEMAX. FEMAX computer program predicts complex eigenvalues and eigenvectors for the aircraft engine rotors. (3) Add local coordinate system capability for BEAM elements to FEMAX. BEAM elements in FEMAX currently use global coordinate system. (4) Add stress prediction capability to FEMAX. (5) Verify the additions made to FEMAX and write a report.

---

**Use of Left Eigenvectors for Modal Analysis of  
Vibratory Systems with Non-Symmetric Dynamic Properties**

**ABSTRACT:**

Dynamic responses of large-order linear systems are usually obtained by modal analysis in which the coupled equations of motion of the physical coordinates are uncoupled via a linear transformation that employs the mode shapes of the system. The uncoupled equations of motion, described in modal coordinates, can then be solved as independent single degrees of freedom units. Solutions to the uncoupled modal coordinates can easily be transferred back to the physical coordinates. Modal analysis can successfully be applied to dynamic systems having symmetric inertia, damping and stiffness properties. The constraint of symmetry on the system's dynamic properties restricts the application of the conventional modal analysis to rotor-systems that have non-symmetric stiffness and damping properties as the results of the force fields stemming from the bearing fluid films and gyroscopic effects. This work presents a variation to the conventional modal analysis in which a set of so called "left eigenvectors" are determined and used in conjunction with the conventional eigenvectors, or more properly termed "right eigenvectors", for uncoupling the equations of motion of systems with non-symmetric dynamic properties. The methodology has been applied to transient analysis of two (2) simple systems, one with non-symmetric coefficients and the other one with symmetric properties.

**INTRODUCTION:**

There are several approaches for modal analysis of rotor systems in which the dynamic properties (damping and stiffness matrices) are non-symmetric. The most common conventional approach is that of A.J. Dennis in which all of the non-symmetric portions of the dynamic coefficients and the symmetric damping are transferred to the right hand side of the equations of motion. This leaves an undamped symmetric systems on the left side of the equations of motion that has real modes (as oppose to complex conjugate modes). In this method, the equations of motion of the modified undamped symmetric system are uncoupled and all damping and gyroscopic damping and stiffnesses are treated as external forces. When the uncoupled equations of motion are being integrated in time by a numerical algorithm, the velocity information, needed for the right hand side of the equations of motion,

have to be brought from a previous time step of the integration. In other words, the force field stemmed from the damping and gyroscopic effects lag the other interacting forces by a time step of the numerical algorithm. This method produces acceptable accuracy for the results when the number of selected modes in the back transformation to the physical coordinates approaches the total number of degrees of freedom of the system.

A more rational approach, under represented in literature in terms of solved examples, is the use of "left eigenvectors" along with the "right eigenvectors" that rectifies the shortcoming of the standard modal analysis for uncoupling of equations of motion for the rotor-systems with non-symmetric properties. The reader is referred to "Matrix Computations", 2nd Edition, by Gene H. Golub and Charles F. Van Loan, for a detailed discussion on the concept of eigenproblem solutions for non-symmetric systems. The following are two examples for which the equations of motion are made uncoupled by the "left and right eigenvectors"

### Example 1:

Transient response of a 2 degree of freedom journal bearing system as a result of a half-sine-wave pulse:

System Properties (non-symmetric):

$$[m] = \begin{bmatrix} 5.5 & 0 \\ 0 & 5.5 \end{bmatrix}$$

$$[c] = \begin{bmatrix} 10 & 1.5 \\ 2.5 & 8.5 \end{bmatrix}$$

$$[K] = \begin{bmatrix} 1.5 & 5.5 \\ -4.5 & 2.5 \end{bmatrix}$$

$$\{f(t)\} = \begin{cases} 100 \sin t & 0 \leq t \leq 1.0 \\ 0 & t > 1.0 \end{cases}$$

Example 1:

Transient forced Analysis of a Journal Bearing:

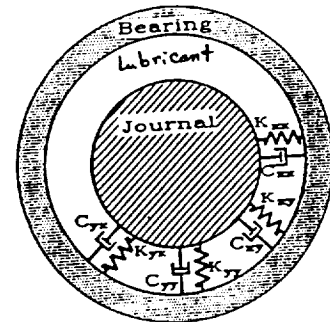
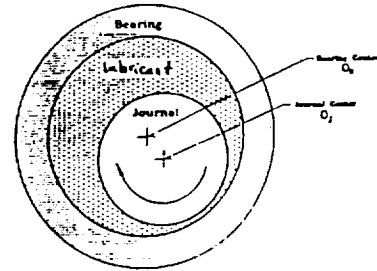

$$S = (R/c)^2 \frac{\mu N}{P} \quad \text{Sommerfeld number}$$

$$\begin{bmatrix} M & 0 \\ 0 & M \end{bmatrix} \begin{Bmatrix} X \\ Y \end{Bmatrix} + \begin{bmatrix} C_{xx} & C_{xy} \\ C_{yx} & C_{yy} \end{bmatrix} \begin{Bmatrix} \dot{X} \\ \dot{Y} \end{Bmatrix} + \begin{bmatrix} K_{xx} & K_{xy} \\ K_{yx} & K_{yy} \end{bmatrix} \begin{Bmatrix} X \\ Y \end{Bmatrix} = \begin{Bmatrix} f_x(t) \\ f_y(t) \end{Bmatrix}$$

1st Eigenvalue = .00029216, .550181181  
 2nd Eigenvalue = .00029216, -.550181181  
 3rd Eigenvalue = -1.68211035, .531972101  
 4th Eigenvalue = -1.68211035, -.531972101

here is the Left Eigen vector matrix

.4453	-.1508	.4453	.1508	-.5740	-3.2477	-.5740	3.2477
.0003	.5502	.0003	-.5502	-1.6821	.5320	-1.6821	-.5320
-1.2737	-.8095	-2.737	.8095	-.2449	1.8533	-.2449	-1.8533
1.0000	.0000	1.0000	.0000	1.0000	.0000	1.0000	.0000

here is the Right Eigen vector matrix

-.5519	-.0660	-.5519	.0660	-.2728	1.1215	-.2728	-1.1215
.0003	.5502	.0003	-.5502	-1.6821	.5320	-1.6821	-.5320
-.1204	1.0030	-.1204	-1.0030	.3391	-.5595	.3391	-.5595
1.0000	.0000	1.0000	.0000	1.0000	.0000	1.0000	.0000

Here is the ult\*a\*ur matrix

17.3141	10.6871	.0000	.0000	.0000	.0000	.0000	.0000
.0000	.0000	17.3141	-10.6871	.0000	.0000	.0000	.0000
.0000	.0000	.0000	.0000	-22.1125	6.3057	.0000	.0000
.0000	.0000	.0000	.0000	.0000	.0000	-22.1125	-6.3057

Here is the ult\*b\*ur matrix

5.8748	-9.5290	.0000	.0000	.0000	.0000	.0000	.0000
.0000	.0000	5.8748	9.5290	.0000	.0000	.0000	.0000
.0000	.0000	.0000	.0000	-33.8412	22.3701	.0000	.0000
.0000	.0000	.0000	.0000	.0000	.0000	-33.8412	-22.3701

Here is the urinv\*s\*ur matrix

.0003	.5502	.0000	.0000	.0000	.0000	.0000	.0000
.0000	.0000	.0003	-.5502	.0000	.0000	.0000	.0000
.0000	.0000	.0000	.0000	-1.6821	.5320	.0000	.0000
.0000	.0000	.0000	.0000	.0000	.0000	-1.6821	-.5320



Half sinwave pulse force on the journal  
 Duration of the pulse = 0.0 sec  
 Bearing Sommerfeld number,  $S = 2.0$   
 Maximum applied force, 100 Lbs.  
 $RPM = 5000$

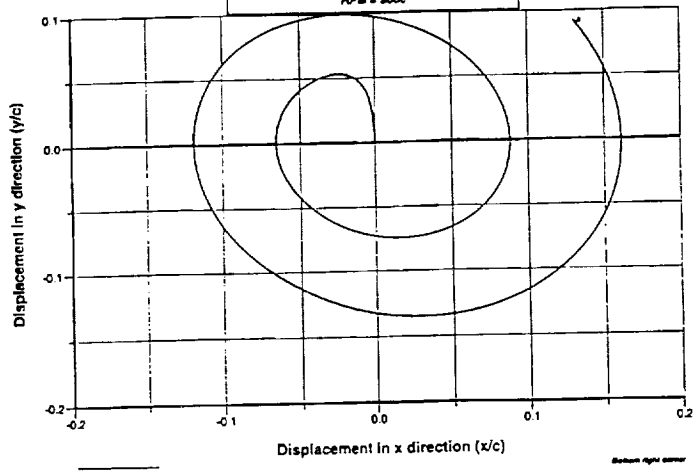

Runway Shape: Random, with  $y_0 = 0.1$  in.  
 Vel. Shock: sawtooth,  $t_1 = 0.125, t_2 = 0.1$  sec.  
 $v_{max1} = 100$  in/sec,  $v_{max2} = 50$  in/sec  
 $t_{per} = 1$  sec. Tire stiffness = 2000 lb/in  
 Landing gear stiffness = 850 lb/in  
 Weights (lbs):  $w_1 = w_3 = 500, w_2 = 2000, w_4 = 200$

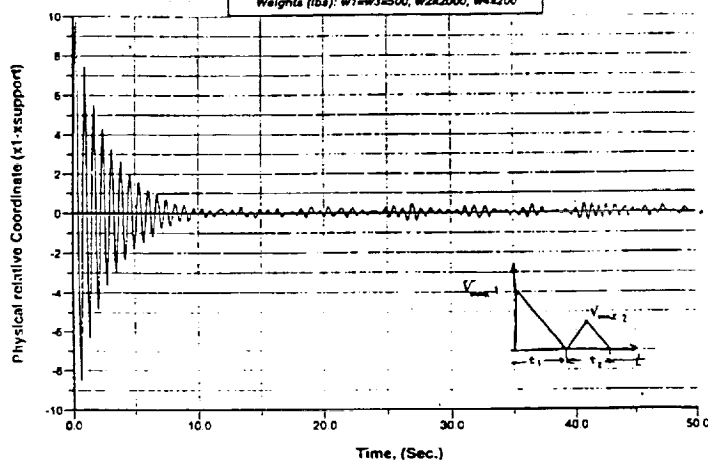

Runway Shape: Random, with  $y_0 = 0.1$  in.  
 Vel. Shock: sawtooth,  $t_1 = 0.125, t_2 = 0.1$  sec.  
 $v_{max1} = 100$  in/sec,  $v_{max2} = 50$  in/sec  
 $t_{per} = 1$  sec. Tire stiffness = 2000 lb/in  
 Landing gear stiffness = 850 lb/in  
 Weights (lbs):  $w_1 = w_3 = 500, w_2 = 2000, w_4 = 200$

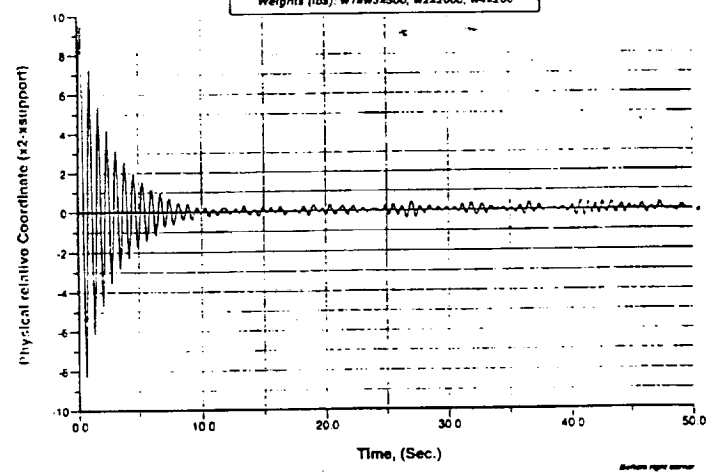

Runway Shape: Random, with  $y_0 = 0.1$  in.  
 Vel. Shock: sawtooth,  $t_1 = 0.125, t_2 = 0.1$  sec.  
 $v_{max1} = 100$  in/sec,  $v_{max2} = 50$  in/sec  
 $t_{per} = 1$  sec. Tire stiffness = 2000 lb/in  
 Landing gear stiffness = 850 lb/in  
 Weights (lbs):  $w_1 = w_3 = 500, w_2 = 2000, w_4 = 200$

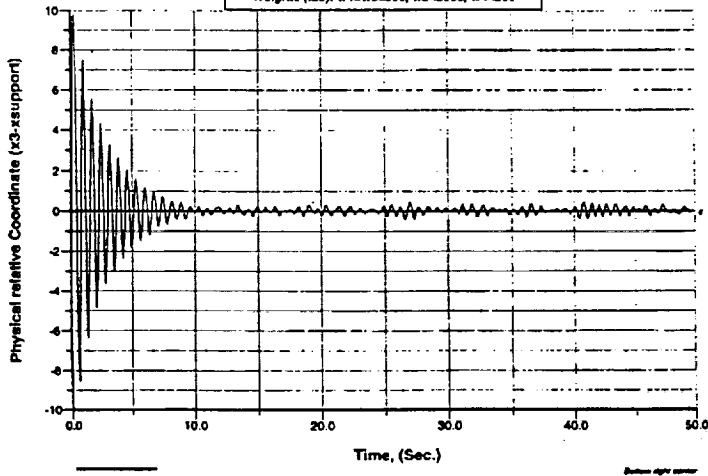

Runway Shape: Random, with  $y_0 = 0.1$  in.  
 Vel. Shock: sawtooth,  $t_1 = 0.125, t_2 = 0.1$  sec.  
 $v_{max1} = 100$  in/sec,  $v_{max2} = 50$  in/sec  
 $t_{per} = 1$  sec. Tire stiffness = 2000 lb/in  
 Landing gear stiffness = 850 lb/in  
 Weights (lbs):  $w_1 = w_3 = 500, w_2 = 2000, w_4 = 200$

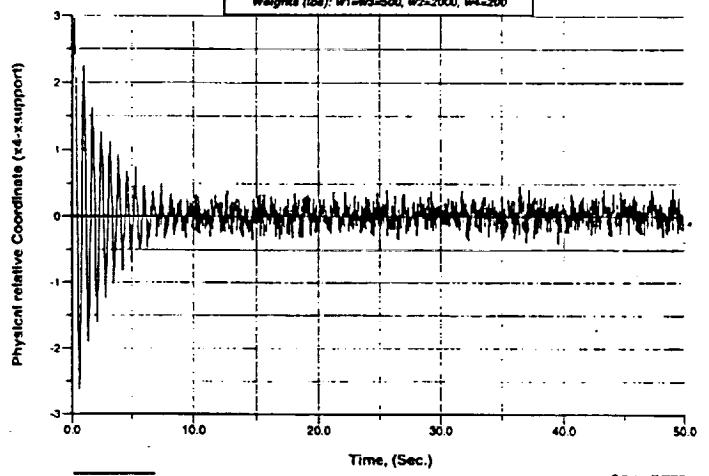

**Example 2:**

Landing of a 4 degrees of freedom airplane system

System Properties (symmetric):

$$[m] = \begin{bmatrix} 1.3 & 0 & 0 & 0 \\ 0 & 5.18 & 0 & 0 \\ 0 & 0 & 1.3 & 0 \\ 0 & 0 & 0 & .52 \end{bmatrix}$$

$$[c] = 10^{-2} \times [K]$$

$$[k] = \begin{bmatrix} 3400 & -3400 & 0 & 0 \\ -3400 & 7650 & -3400 & -850 \\ 0 & -3400 & 3400 & 0 \\ 0 & -850 & 0 & 2850 \end{bmatrix}$$

$\{f(t)\}$  = Velocity profile imposed to the landing gear (shown in Figure)

Transient Response of a plane landing:

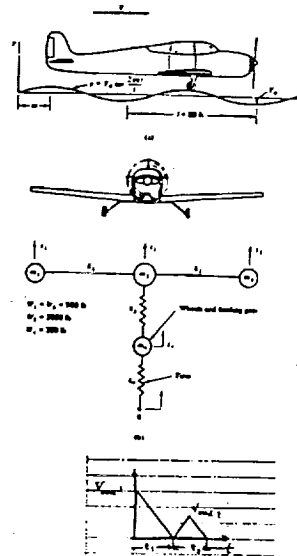

Potential Application and Usefulness of the Present Work:

Dynamic and vibration analysis of:

- High speed rotors that experience gyroscopic moments and centrifugal forces as the results of fast maneuvering (aircraft engines, helicopter engines, fuel pumps of rocket, etc.)
- Earthbound rotating machinery that may experience seismic support excitation.

Name: Steven P. Rooke  
Education: Ph.D., Mechanical Engineering  
Purdue University

Permanent Position: Assistant Professor, Mechanical Engineering  
University of Akron

Host Organization: Instrumentation and Control Technology Division  
Colleague: Gustave C. Fralick

Assignment:

Professor Rooke will be participating in both experimental and theoretical determination of the frequency and step response of various types of heat flux gauges. Heat flux is one of a number of quantities whose measurement is of interest to the aerospace community. It is desirable that the gauge respond to a change in heat flux as rapidly as possible. The calculations to be done will begin with a mathematical model under development at Lewis. Professor Rooke will contribute to its refinement. The calculations will be checked against the behavior of gauges responding to changes in heat flux.

---

### Heat transfer analyses

Heat transfer analyses were performed on two types of heat flux gages. A numerical model was developed to investigate the heat transfer in a plug-type heat flux gage under typical operation. Model results were compared with experimental results. Results of the model have extended the understanding of heat flow in this type of gage.

Development of a second heat transfer model consisted primarily of generating and post processing the model's output. Graphical display of output was developed and was used to make decisions about the future steps in the research.

A 73 page report has been written and is being prepared for submission as a technical paper and/or report.



Name: Gary A. Ruff  
Education: Ph.D., Aerospace Engineering  
University of Michigan

Permanent Position: Associate Professor, Mechanical Engineering and Mechanics  
Drexel University

Host Organization: Propulsion Systems Division  
Colleague: David N. Anderson

Assignment:

The faculty fellow will work with the NASA colleague to explore alternatives to existing icing scaling techniques. In particular, scaling methods for the testing of subscale rotorcraft will be explored, including the development of mathematical models to describe the physics of ice shedding from rotating components. In addition to forming the basis of a technique to scale icing tests of rotorcraft, these models would be suitable for incorporation into the NASA Lewis ice-accretion code, LEWICE. Some experimental rotorcraft icing data exists at Lewis, and analysis of these data may be needed to validate the models; assistance in this analysis may be provided by a summer intern student. Experiments will be planned to evaluate the resulting scaling technique(s) in an icing wind tunnel, and a technical paper will be written to document the technique.

---

### Evaluation of Current Icing Scaling Technology

The objective of the research conducted during this fellowship program was to review the current state of icing scaling technology and suggest additional experiments, theories, or analysis that would be helpful in bringing this test technique closer to universal acceptance in the icing community. Progress towards this objective was made which should lead to the definition of some standard procedures for this technique.

Icing scaling is a test technique to allow geometrically-similar ice accretions to be formed on geometrically-scaled test articles or on a full-scale test article but using different test conditions. Both size and test parameter scaling are applied to overcome the size or operational limitations of a test facility. There are two basic approaches for scaling icing test conditions: an exact scaling methodology based on the Buckingham- $\pi$  theorem and a phenomenological method developed from models of the ice accretion process. The phenomenological approach is the most popular with several versions existing in the literature. While most of these have been verified to some degree, none have received universal acceptance because either contradictory data has been obtained or the method is too restrictive to be applied in all facilities. The Buckingham- $\pi$  method requires no assumptions about the ice accretion process to be made. However, it is impossible to apply the exact scaling suggested by this method. Even when applying an approximate scaling based on maintaining the most important of the  $\pi$  parameters, contradictions arise because of the complex phenomena occurring in the ice accretion process. One of the accomplishments during this fellowship period was to evaluate the relationships between the phenomenological and exact scaling methodologies. It was found that, in general, they are not contradictory. The parameters used in the phenomenological approach can be obtained from the exact Buckingham- $\pi$  approach, although a physical model must be used to deduce the appropriate functional relationship.

Research has shown that for certain types of icing conditions, test parameter scaling can be applied to produce ice accretions that are scaled very well. When this same method is

applied on subscale models, the scaling is at times very good and at other times unsatisfactory. Current research is focusing on why these variations occur so that scaling test techniques can be used with greater confidence.

One feature that is lacking in the current model of ice accretion is a detailed understanding of the dynamics of liquid water on the surface of the initially clean airfoil and later on an ice substrate. Various phenomena can play a role including droplet splashing, beading and movement of water drops, formation and flowing of a thin liquid film, and formation of roughness elements. The importance of these phenomena were investigated during the fellowship period by examining existing literature and test results. It was determined that the beading and movement of water drops on the surface and the subsequent formation of roughness elements were likely to be the most significant for the ice accretion process. Both of these phenomena are lacking from the current scaling technology. Two models of the motion of liquid water on a clean or iced surface were developed and incorporated into scaling methodologies which will be evaluated during tests to be conducted in the Icing Research Tunnel at NASA Lewis and in the Icing Wind Tunnel at BFGoodrich Aerospace in Akron at the end of August 1996.

Several recommendations for future work in icing scaling technology were also developed. These are identified below:

1. The "goodness" of these scaling methods must be better quantified using a statistical analysis, probably based on ice accretion dimensions. In many respects, we know how to scale ice accretions fairly well but have not quantified how much better can be expected or is required. A plan for this work was developed during this fellowship period.

2. Data from tests conducted at NASA Lewis exist which could be used to identify how the size of roughness elements on an ice accretion scale with atmospheric and flight conditions and size of the test article. This information is required to ensure that the enhanced heat transfer from the rough ice surface is properly scaled.

Detailed results of the work accomplished during this fellowship period will be presented at the SAE AC-9C subcommittee meeting to be held this fall. The purpose of this meeting is to review icing scaling technology and determine whether standards for the test procedure can be developed. If not, gaps in our understanding of the ice accretion process that must be filled before such a standard can be written will be identified.



Name: Tom I-P. Shih  
Education: Ph.D., Mechanical Engineering  
University of Michigan

Permanent Position: Professor, Mechanical Engineering  
Carnegie Mellon University

Host Organization: Internal Fluid Mechanics Division  
Colleague: Brian P. Willis

Assignment:

Professor Shih's assignment will be in the area of inlet bleed boundary layer control. He will be involved with modifying a 3-D Navier Stokes solver, NPARC. This activity strongly supports efforts underway here at Lewis to develop a global model to handle CFD bleed boundary conditions. If time permits, Professor Shih will be converting/installing a grid generation package (developed by his graduate students for Ames) which local CFD researchers will be able to utilize in their efforts. Accompanying Student: Mark A. Stephens.

---

## Control of Shock-Wave/Boundary Layer Interactions by Bleed

### I. Introduction/Objectives

Shock-wave/boundary-layer interactions and their effective control play an important role in the operation of mixed-compression supersonic inlets. These inlets utilize shock waves to reduce the incoming air from supersonic to subsonic speeds for the compressor. But, the many reflected shock waves within the inlet thicken boundary layers and cause flow distortions. Also, if the shock waves are sufficiently strong, then boundary-layer separations take place which can lead to the unstart condition.

One widely used method for controlling detrimental effects of shock-wave/boundary-layer interactions is bleed. Control through bleed consists of placing holes or slots in vicinities where shock waves impinge on the boundary layer. These bleed holes, being connected to one or more plenums at lower pressures, remove the low momentum fluid next to the wall so that the remaining boundary layer, having higher momentum, can now withstand the adverse pressure gradient without separating. Although bleed is an effective method of control, it has associated penalties. In the case of supersonic mixed-compression inlets, removal of boundary layer fluid reduces mass flow for propulsion, decreases total pressure recovery, and increases drag because of the need to vent bled air into the freestream. Thus the designer must try to bring about the most effective control with the least amount of bleed.

The importance of bleed in controlling shock-wave/boundary-layer interactions has led a number of investigators to use both experimental and numerical methods to study this problem. Numerical studies of shock-wave/boundary-layer interactions with bleed fall into two groups. One group models the bleed process by using boundary conditions and/or a roughness model without resolving the flow through the bleed holes (e.g., Refs. 1-3). The advantage of this approach is that it is more efficient computationally which enables a complete inlet configuration to be simulated as was done in Refs. 1 and 3. The other group studies the bleed process by resolving the flow through each bleed hole (e.g., Refs. 4-9). The advantage of this approach is that it can reveal the nature of the flow governing the bleed process. The understanding gained by these studies can guide the construction of boundary conditions and roughness models used by the first group.

With the above backdrop, the objectives of our overall research effort in this area are twofold. First, investigate and explore the various flow physics created by bleed through CFD simulations

that resolve the flow through each individual bleed hole as a function of bleed-hole geometry, plenum back pressure, and profiles of the approaching boundary-layer flow. Second, from the understanding gained under the first objective, develop a "comprehensive bleed model" that can be used as a "bleed boundary condition" by CFD simulations of realistic inlets over the bleed zone without the need to resolve the flow through individual bleed holes.

## II. Accomplishments

During this summer steady progress was made towards accomplishing both of the aforementioned objectives. The progress made are divided into two groups - those with my accompanying student, Mark A. Stephens, and those by myself and my NASA colleague, Brian P. Willis. Efforts with Mark Stephens include the following:

1. Found a major limitation in OVERFLOW, a Navier-Stokes solver used in all of our previous studies (Refs. 6-9). That limitation is extremely slow convergence when flow in the entire plenum is of interest. This observation was made while using OVERFLOW to study the effects of plenum size on shock-wave/boundary-layer interactions with bleed in which flow through each bleed hole is resolved.

2. Decided to use a different code that has much faster convergence rate for flows in the plenum where the Mach number is generally quite small except near the bleed holes. The code selected is CFL3D. CFL3D is as good as OVERFLOW in being able to handle complex geometries via patched and overlapping grids, but is superior to OVERFLOW in having multigrid capability which greatly increases convergence rate.

3. Adapted CFL3D so that it can be used to study flows with bleed holes. This involved understanding and devising ways to circumvent idiosyncrasies built into CFL3D and two other codes, RONNIE and MAGGIE, that are needed when patched and overlapping grids are used. Issues resolved include ways to handle orphaned points and oscillations at patched boundaries.

4. Supervised Mark Stephen's efforts (with minimal efforts from me) to modify and improve a package called AUTOMAT (see Ref. 10). AUTOMAT is a preprocessor that was developed to generate grid, initial conditions, boundary conditions, and everything else needed to run the OVERFLOW code once a user specifies a specific problem within a class of problems involving shock-wave/boundary-layer interaction on a flat plate with bleed through rows of holes in which flow through each hole is resolved. Modifications made include all changes necessary to run CFL3D instead of OVERFLOW (e.g., grid generated must allow at least four levels of multigrid; grid generated are for cell-centered instead of vertex-centered finite-volume which has relevance to boundary conditions for symmetry planes). Improvements made include automatic generation of input files to run RONNIE and MAGGIE.

Other efforts include:

1. Reviewed and studied literature on shock-wave/boundary-layer interactions with bleed and bleed boundary conditions.

2. Discussed with NASA scientists (primarily Brian Willis and Dave Davis) about what is important and what is needed in the area of inlet research. These discussions are helping me formulate a more relevant research program that will be of greater interest to government and industry. Specifically, new directions and focus include bleed through microholes, optimal control of bleed via micro electro-mechanical systems (MEMS), effects of slant-hole misalignment on flow coefficients, and boundary-layer control by tangential blowing.

3. Developed a framework for a bleed boundary condition that can account for not only the mass removal through bleed holes as a function of bleed hole geometry, approaching boundary-layer profile, and pressure ratio across the bleed holes, but also barrier shocks above the bleed holes.

4. Procured the NPARC code where bleed boundary conditions will be tested, and performed preliminary computations.

## References

1. Chyu, W.J., Howe, G.W., and Shih, T.I-P., "Bleed Boundary Conditions for Numerically Simulated Mixed-Compression Supersonic Inlet Flows," AIAA J. of Propulsion and Power, Vol. 8, 1992, pp. 862-868.
2. Lee, J., Sloan, M.L., and Paynter, G.C., "A Lag Model for Turbulent Boundary Layers Developing over Rough Bleed Surfaces," AIAA J. of Propulsion and Power, Vol. 10, No. 4, 1994, pp. 562-568.
3. Harloff, G.J. and Smith, G.E., "On Supersonic-Inlet Boundary-Layer Bleed Flow," AIAA Paper 95-0038, January 1995.
4. Hahn, T.O., Shih, T.I-P., and Chyu, W.J., "Numerical Study of Shock-Wave / Boundary-Layer Interactions with Bleed," AIAA J., Vol. 31, No. 5, 1993, pp. 869-876.
5. Hamed, A. and Lehnig, T., "Effect of Bleed Configuration on Shock/Boundary Layer Interactions," AIAA J. of Propulsion and Power, Vol. 11, No. 1, 1995, pp. 42-48.
6. Shih, T.I-P., Rimlinger, M.J., and Chyu, W.J., "Three-Dimensional ShockWave/Boundary-Layer Interactions with Bleed," AIAA J., Vol. 31, No. 10, 1993, pp. 1819-1826.
7. Chyu, W.J., Rimlinger, M.J., and Shih, T.I-P., "Effects of Bleed-Hole Geometry and Plenum Pressure on Three-Dimensional Shock-Wave/Boundary-Layer/Bleed Interactions," AIAA J., Vol. 33, No. 7, 1995, pp. 1239-1247.
8. Rimlinger, M.J., Shih, T.I-P., and Chyu, W.J., "Three-Dimensional ShockWave/Boundary-Layer Interactions with Bleed through Multiple Holes," AIAA J. of Propulsion and Power, Vol. 12, No. 2, 1996, pp. 217-224.
9. Rimlinger, M.J., Shih, T.I-P., Chyu, W.J., Willis, B.P., and Davis, D.O., "Computations of Shock-Wave/Boundary-Layer Interactions with Bleed", AIAA Paper 960432, January 1996.
10. Chyu, W.J., Rimlinger, M.J., and Shih, T.I-P., "A Procedure for Automating CFD Simulations of an Inlet-Bleed Problem," NASA Workshop on Surface Modelling, Grid Generation, and Related Issues in CFD Solutions," NASA CP-3291, NASA - Lewis Research Center, May 1995, pp. 731-749.

11/11/2020 10:11:11 AM

11/11/2020 10:11:11 AM

11/11/2020 10:11:11 AM

1

Name: Mark A. Stephens  
Education: Carnegie Mellon University

Permenant Position: Student  
Carnegie Mellon University

Host Organization: Internal Fluids Mechanics Division  
Colleague: Brian P. Willis

Assignment:

Accompanying student under the direction of Professor Tom I-P. Shih.

---

## CFD TOOLS FOR INLET-BLEED STUDIES

### I. Introduction/Objectives

Shock-wave/boundary-layer interactions and their effective control through bleed play an important role in the operation of mixed-compression supersonic inlets. These inlets utilize shock waves to reduce the incoming air from supersonic to subsonic speeds for the compressor. But, the many reflected shock waves within the inlet thicken boundary layers and cause flow distortions. Also, if the shock waves are sufficiently strong, then boundary-layer separations take place which can lead to the unstart condition.

The importance of bleed in controlling shock-wave/boundary-layer interactions has led a number of investigators to use both experimental and numerical methods to study this problem. The objective of my research during this summer was to assist my advisor, Dr. Tom I-P. Shih, in developing CFD tools that can be used to study the flow physics associated with shock-wave/boundary-layer interactions with bleed in inlets and inlet-bleed systems.

### II. Accomplishments

Accomplishments made during this summer are divided into two groups - those with my advisor, Professor Shih, and those by myself under my advisor's supervision. Efforts with Professor Shih include the following:

1. Found a major limitation in OVERFLOW, a Navier-Stokes solver that was used in a previous studies by my advisor and his co-workers to investigate shock-wave/boundarylayer/bleed interactions (e.g., see Refs. 1 to 4). That limitation is extremely slow convergence when flow in the entire plenum is of interest. This observation was made while using OVERFLOW to study the effects of plenum size on shock-wave/boundarylayer interactions with bleed in which flow through each bleed hole is different.
2. Decided to use a different code that has much fster convergence rate for flows in the plenum where the Mach number is generally quite small except near the bleed holes. The code selected is CFL3D. CFL3D is as good as OVERFLOW in being able to handle complex geometries via patched and overlapping grids, but is superior to OVERFLOW in having multigrid capability which greatly increses convergence rate.
3. Adapted CFL3D so that it can be used to study flows with bleed holes. This involved understanding and devising ways to circumvent idiosyncrasies built into CFL3D and two other codes, RONNIE and MAGGIE, that are needed when patched and overlapping grids are used. Issues resolved include ways to handle "orphaned points" and oscillations at patched boundaries.

Efforts by myself under my advisor's supervision involved modifying and improving a code called AUTOMAT (see Refs. 5 and 6). AUTOMAT is a preprocessor that was developed to generate grid, initial conditions, boundary conditions, and everything else needed to run the OVERFLOW code once a user specifies a specific problem within a class of problems involving shock-wave/boundary-layer interaction with bleed. That class of problems is shock-wave/boundary-layer interactions on a flat plate with bleed through rows of holes in which flow through each hole need to be resolved.

Modifications made by me to AUTOMAT were so that it will provide all files needed to run CFL3D instead of OVERFLOW. The most significant modification was in the grid generation program. This includes modifications to ensure that grids generated will allow at least four levels of multigrid. Also, grid generated are for cell-centered instead of vertexcentered finite-volume which has relevance to boundary conditions for symmetry planes.

Improvements made by me to AUTOMAT include the following:

1. Developed a program in AUTOMAT to automatically generate input files to run RONNIE and MAGGIE. This is a very important addition to AUTOMAT since RONNIE and MAGGIE are not easy to run and require complicated input files.
2. Generalized AUTOMAT to run on multiple platforms (e.g., Cray, Iris, HP).
3. Optimized the programming of AUTOMAT so that it will run more efficiently.
4. Optimized and improved the grid generation program in AUTOMAT to give better quality grids.
5. Made AUTOMAT more user friendly with regard to input.
6. Provided routines to allow post-processing of data from CFL3D and OVERFLOW by using Tecplot in addition to PLOT3D and FAST.
7. Added Huang/Bradshaw boundary-layer profile as inflow boundary conditions.

## References

1. Shih, T. I-P., Rimlinger, M.J., and Chyu, W.J., "Three-Dimensional ShockWave/Boundary-Layer Interactions with Bleed," AIAA J., Vol. 31, No. 10, 1993, pp.1819-1826.
2. Chyu, W.J., Rimlinger, M.J., and Shih, T.I-P., "Effects of Bleed-Hole Geometry and Plenum Pressure on Three-Dimensional Shock-Wave/Boundary-Layer/Bleed Interactions," AIAA J., Vol. 33, No. 7, 1995, pp. 1239-1247.
3. Rimlinger, M.J., Shih, T.I-P., and Chyu, W.J., "Three-Dimensional Shock-Wave/Boundary-Layer Interactions with Bleed through Multiple Holes," AIAAJ. Of Propulsion and Power, Vol. 12, No. 2, 1996, pp. 217-224.
4. Rimlinger, M.J., Shih, T.I-P. Chyu, W.J., Willis, B.P., and Davis, D. O., "Computations of Shock-Wave/Boundary-Layer Interactions with Bleed," AIAA Paper 96-0432, January 1996.
5. Rimlinger, M.J., Chyu, W.J., and Shih, T.I-P., "AUTOMAT — A Preprocessor for CFD Parametric Studies of Inlet-Bleed Systems," Final Technical Report, NASA-Ames University Consortium, 1994.
6. Chyu, W.J., Rimlinger, M.J., and Shih, T.I-P., "A Procedure for Automating CFD Simulations of an Inlet-Bleed Problem," NASA Workshop on Surface Modelling, Grid Generation, and Related Issues in CFD Solutions," NASA CP-3291, NASA-Lewis Research Center, May 1995, pp. 731-749.

Name: Stephen P. Tanner  
Education: Ph.D, Chemistry  
University of Manchester, United Kingdom

Permanent Position: Chairman, Department of Chemistry  
University of West Florida

Host Organization: Chemical Sampling and Analysis Office  
Colleague: Kenneth W. Street

Assignment:

The fellowship program outlined for Dr. Tanner consists of two projects. The first is the finish of a project initiated by him and me several years ago and the second consists of a project that was initiated by him and Ms. Priscilla Mobley last year. (1) Final evaluation of a lead in drinking water test kit. A home use test kit for testing the lead content in drinking water was developed in conjunction with funding received by LeRC from the US Army, Corps of Engineers. The kit developed needs optimization of flow rate, alcohol content then field testing. Many of these experiments require periods of immediate attention followed by prolonged periods of intermittent attention. This project would dovetail nicely with another project placing a similar time constraint on the researcher. (2) Optimization of microwave digestion of oil sample for mercury analysis. A microwave procedure was devised last summer for the determination of mercury in pump oil which requires disposal. The crude procedure devised in the past summer needs optimization with respect to the amounts of digestion reagents and microwave time required versus number of samples treated. The procedure further requires a study of the efficacy of this treatment for silicon based oils. This project will require short periods of immediate attention and prolonged periods where no attention is required.

---

#### **Analysis of Mercury in Silicone Oil and Studies on NASA Ion Exchange Material**

The analysis of mercury in silicone oil is of major importance to Lewis Research Center and to the Environmental Sampling and Analysis Laboratory. The use of silicone oil and mercury in high vacuum pumps creates a waste disposal problem. If the oil contains more than 0.2ppm of mercury it is considered hazardous and must be disposed of accordingly. The Environmental Analysis Laboratory is called upon to analyze the silicone oil for mercury at these concentration levels and to determine the appropriate disposal procedure.

The normal digestion methods used to release mercury from organic oils and most solid samples are not successful for silicone oil. The difficulty in oxidation and the tendency of silicones to further polymerize, lead to erratic results and low recoveries. This summer a method has been developed which gives consistent results and recoveries in the range 70-95%. The method involves multiple heatings in a teflon digestion bomb in a microwave oven with oxidizing acid mixtures and with hydrofluoric acid. The latter step is necessary to dissolve the solid polymeric material produced by the reaction of acids with silicone and which is believed to trap mercury in the matrix of the solid. Studies have been conducted on oil samples containing 0.1 to 10ppm of mercury. After microwave digestion, the resulting solutions of mercury(II) are analyzed by flow injection cold vapor atomic absorption spectroscopy.

The Office of Environmental Programs is also involved in two pilot scale projects using the NASA Ion Exchange Material(IEM). One of these projects concerns the remediation of lead contaminated soil using IEM beads, and the other is the treatment of waste water from electroplating companies, using IEM film. I have determined the kinetics of metal ion uptake and the capacity of both forms of the IEM and also assisted with the evaluation of the a pilot plant size ion exchange rig which uses 1000 ft rolls of fiberglass supported IEM films.

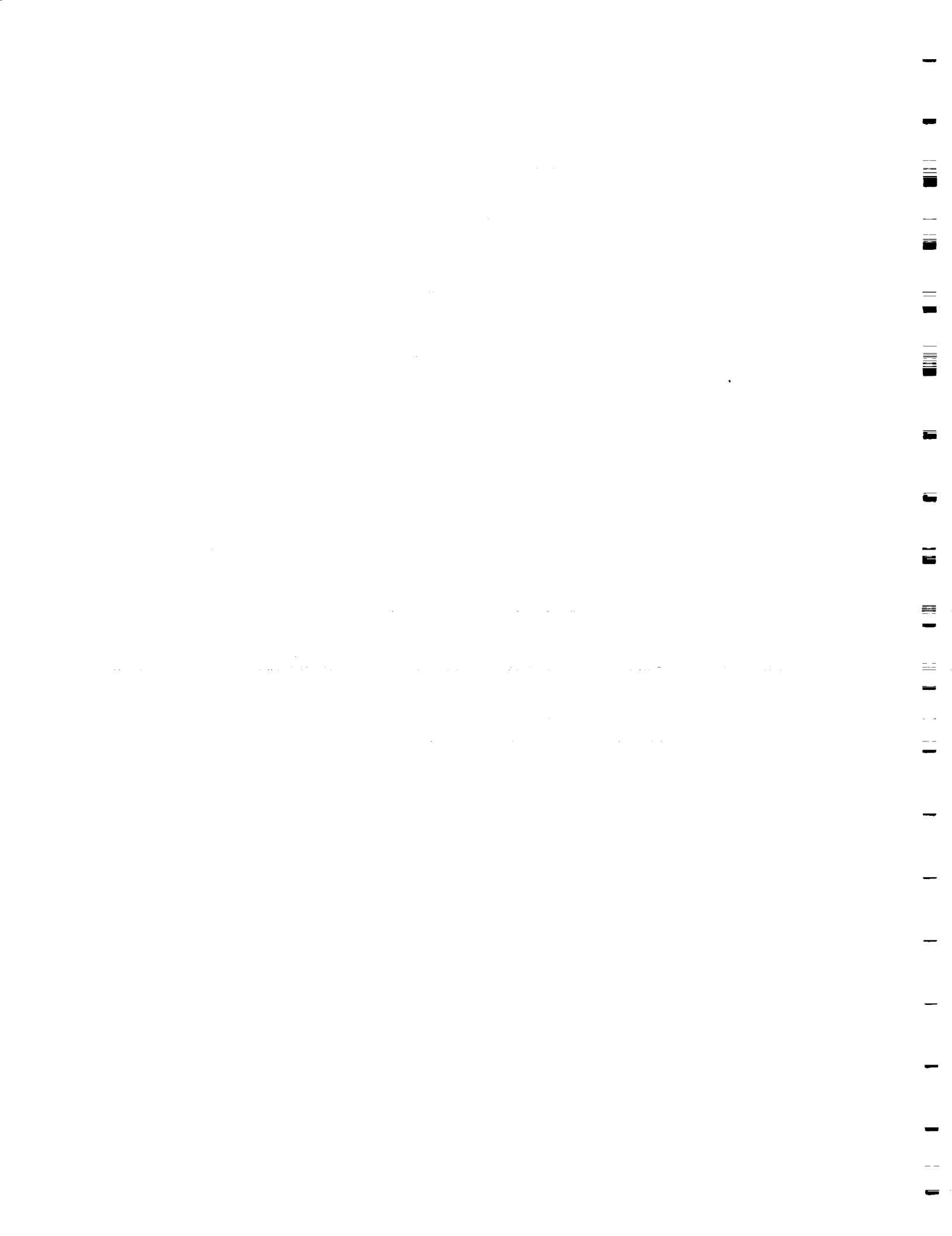



Name: Thomas W. Taylor  
Education: Ph.D., Physics  
Oklahoma State University

Permanent Position: Associate Professor, Physics  
Cleveland State University

Host Organization: Materials Division  
Colleague: Thomas K. Glasgow

Assignment:

Extend work on cross-correlation with bulk light scattering to suppress multiple scattering. This will consist of adding grid lenses to fibers to collimate or focus detected portion of beam. Build 180 degree backscatter probe with local oscillator with variable position beam absorber.

---

**Cross Correlation Dynamic Light Scattering  
to Determine Particulate Sizes in Dense Suspensions of Polystyrene Sphere Aqueous  
Suspensions**

My project for the summer was to work with fiber optic arrays to investigate dense suspensions of polystyrene spheres in water. In dense suspensions multiple scattering of the light, scattering from more than one particle before exiting the suspension, is extremely likely and a problem. All information on particulate size is carried in the light that scatters from a single particle before exiting the sample and impinging on the detector. Several techniques to solve this problem have been developed in recent years but they involve the use of two colors of light and delicate optical alignment. I investigated a new technique developed at NASA Lewis Research Center that alleviates the problem. This technique involves using a fiber optic array and two detectors. The signal from the detectors is crosscorrelated and the correlogram is analyzed to determine the particle size. The signal from the detectors is only correlated if the light is scattered a single time from a particle. If the light happens to have scattered more than once, the signal at the two detectors is uncorrelated and only adds to the background noise.

The fiber optic array was used to measure the intensity fluctuations in a particulate suspension that ranged from 1.76 E-3 to 5.0 volume %. The auto-correlation function of the scattered light was measured from each of the two fibers in the probe and the cross-correlation function between the two separate probes was also measured. The suspensions contained polystyrene particles with a nominal diameter of either 40 nm or 98 nm particles. The angular dependence was also measured. The suspensions varied in appearance from almost transparent to milky in appearance. The auto-correlation sizes changed by a factor of ten, while the cross-correlation sizes remained the same through most of the concentrations. There was a small reduction in the measured size of the of the particulates for concentrations in the 1 - 5 volume % range. The signal to noise ratio was around 70 % for the autocorrelation at modest concentrations and about 20 - 30 % for the most concentrated solutions. For cross correlation the signal to noise ratio was angularly and concentration dependent. It ranged from a high of 40 % for dense suspensions at 90° to 0.1 % at the higher concentrations.

All autocorrelation data was accumulated for 1 minute at all concentrations and angles, but the data for the cross-correlation was accumulated for varying time depending on the signal to noise ratio. The longest accumulation time was for 20 minutes when the signal to noise ratio was 0.1 %. In addition the laser power was varied between 250 mW and 1.00 W to keep the photon count rate between 100 and 4000 kilocounts/second. A sample of the results are shown in the following graphs. It is apparent that the cross correlation technique is extremely effective for determining particulate sizes in dense colloidal suspensions.

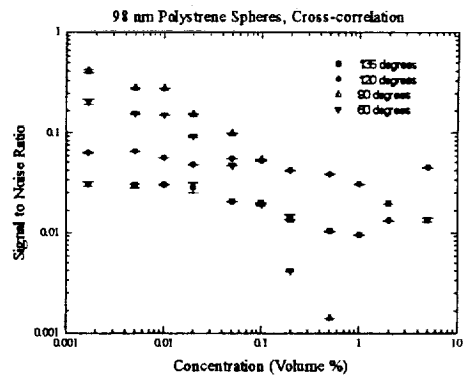
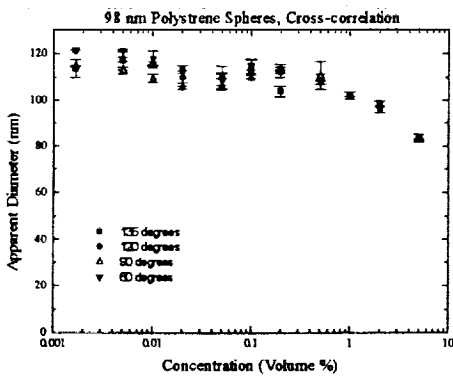
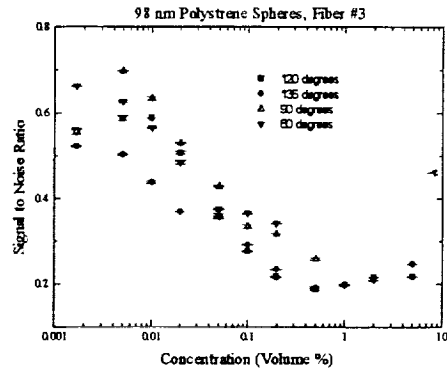
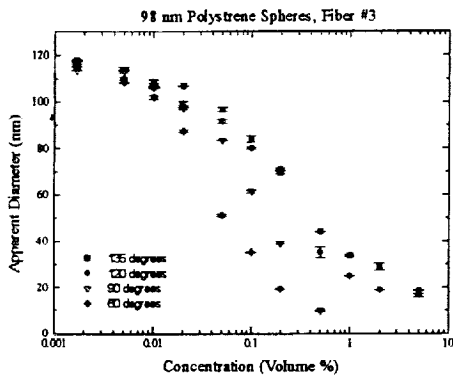
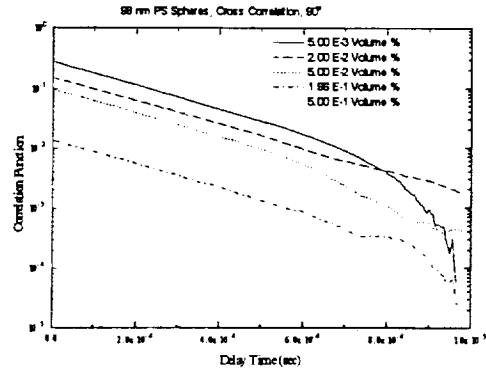
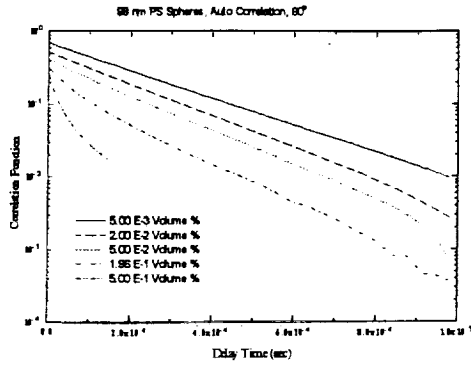

Name: Joseph P. Tenerelli, Jr.  
Education: Ph.D., Mass Communication  
University of Iowa

Permanent Position: Associate Professor, Communication  
Indiana State University

Host Organization: ACTS Project Office  
Colleague: Ronald J. Schertler

**Assignment:**

The ACTS Project Office has a need to develop a series of Video New Releases to highlight the success of the ACTS Program. Fellow will review the videos and video footage currently on hand in the ACTS Project Office and make recommendation on how such footage could be repackaged into a series of videos for both nontechnical and technical audience. If time permits, fellow will oversee the reediting of this footage. In addition, the fellow will develop the storyline for a new  $\leq 10$  minute video targeted for network and cable TV audiences. Details of the new storyline are to be developed as time permits.

---

**Research Assignment**

The ACTS Research Office has a need to develop a series of video new releases to highlight the success of the ACTS Program. Fellow would review the videos and video footage currently on-hand in the ACTS Project Office and make recommendation on how such footage could be repackaged into a series of videos for both non-technical and technical audiences. If time permits fellow can oversee the re-editing of this footage. In addition, the fellow is to develop the storyline for a new +/- 10 minute video targeted for network and cable TV audiences. Details of the new storyline are to be developed as time permits.

**Summary**

As is often the case with media audit/analysis-based work, the focus of this project changed somewhat after the fellow's initial analysis of resources was completed. Additionally, several immediate media related needs arose during the fellow's tenure a LeRC. Pre-arrival consensus was the felt need for a series of Video News Release (VNR) which could be targeted to local, regional and, possibly, national audiences. However, media use analysis and on-site interviews of project participants, indicated the existence of needs greater than the creation of VNR's.

Media require that its needs be fulfilled in a timely and responsive fashion. The NBC network was involved with the ACTS Project as an experimenter. The ACTS was being used by NBC in its coverage of the Olympic Torch as it traveled throughout the country. In anticipation of the Torch's arrival in Cleveland, media coverage and narrative of the NASA LeRC connection needed to be created. Strategies were mapped and storylines developed with the Media Relations Office.

Other pressing needs were the creation of new media to be used at Industry, Trade and other types of venues. Fellow participated in team planning, execution and production of materials which were used at the SUPERCOMM '96 trade show in Dallas, TX. Additionally, these materials will also be used at the SCEC, the Lewis Business Expo and the Cleveland Airshow.

A third intervening media-related need was the re-design of the ACTS Demonstration and Visitors room. Although the physical design and information requirements have been created by the ACTS Demo Room Team, fellow has acted in a consultant capacity to those responsible

for the creation of message design and media platforms within the room. Fellow acted in a resource capacity to project members in the areas of media suitability for reuse applications.

Much of the reorientation of the project's initial thrust resulted because of a report prepared by the fellow. The report analyzed Video News Releases from Content, Production, Distribution and Use perspectives. Discussions with the NASA Partner revealed that the creation of VNR's were more complex and required more coordination than the partner had anticipated. Energies were reoriented to uses and applications of video in areas such as the ACTS Demonstration and Visitor's Center as well as the LeRC Visitor's and Information Center. In each of the aforementioned areas the video's are targeted to non-technical, general public audiences.

Fellow had developed an initial storyline [preliminary script and storyboard], The Impact of The Advanced Communications Technology Satellite, which has been distributed to project members for comment. It is anticipated that the project will continue with grant funding and companion as well as ancillary materials will continue to be developed. NASA Partner has indicated a desire that Fellow return Summer, 1997 to continue to develop materials and act in a consultant capacity. Finally, media contacts initiated by Fellow may result in a high data rate/ ISDN experiment and demonstration project for the ACTS Program. This demonstration would showcase the graphics industry and its business applications and needs for ACTS type Ka band satellite communications.

Name: Thomas R. Wayman  
Education: M.S., Aerospace Engineering  
Wichita State University

Permanent Position: Teaching Fellow, Aerospace Engineering  
Wichita State University

Host Organization: Aeropropulsion Analysis Office  
Colleague: Kenol Jules

Assignment:

The modeling of the unsteady flow in a filling/firing/detonating combustor to determine the pulse detonation engine performance will be performed. An analytical model of such process will be constructed using the shock tube theory approach. The following tasks will be performed. A 1-D flow analyses (with area variation) with conservative estimates of engine components performance. A consistent force accounting methodology to determine the implications of airbreathing pulse detonation engine operation and design strategies. An analysis of the implications of utilizing multiple or single chamber designs for various on design/off design flight conditions. An attempt will be made at exploring the concept of zones (each zone is a set of combustors operating synchronously in a multiple tube PDE).

---

### **Pulse Detonation Engine**

As part of the NASA Summer Faculty Fellowship in Aeronautics and Space Research Program I have designed and developed a pulse detonation engine performance program for use a preliminary design tool. A pulse detonation engine is an unsteady propulsion system using detonation or supersonic combustion to produce large, transient pressure and temperature within an open ended tube. On the basis of the Humphrey or constant volume cycle this type of combustion offers improved fuel consumption compared with traditional turbojet engines. In addition, this type of engine is mechanically simple and offers a compact configuration. This type of engine was first developed in the late 1950's but due to misinterpreted experimental results and a limited understanding of intermittent supersonic combustion the development programs were discontinued. Fortunately within the last decade a handful of scientists have begun developing possible configurations for pulse detonation engines.

As a result of these investigations there has become the need to develop a computational design tool for identifying pulse detonation engine performance parameters and applications. Therefore, an analytical engine deck was developed to characterize the filling, firing, and venting of a single pulse detonation engine cycle. This engine deck was developed for a configuration of four engine components: an inlet, an ideal mixer, a combustor, and a nozzle. The program uses portions of two other programs, the NASA Engine Performance Program (NEPP) and the Chemical Equilibrium and Application (CEA) program, to help build the engine deck. From NEPP, the code borrows routines for the inlet and nozzle, which are used to determine ambient conditions, the fill time, and the thrust. From CEA, the code borrows routines for Chapman-Jouguet detonations, which are used to determine the thermodynamic conditions in the unburned and burned gas. Additionally, a combustor venting model was develop using several experimental studies, while the mixer is assumed to be ideal. Finally, The program is configured such that the engine can be operated as either an air-breathing engine or as a rocket engine.

Inputs to the program include flight conditions, the fuel and oxidizer, combustor and nozzle geometry, and constants. From these parameters the code predicts the engines cycle time for single and multiple tube operation, thrust based on the thrust wall or the nozzle, specific thrust, specific fuel consumption, specific impulse, and thrust per unit area.

1. The first part of the document discusses the importance of maintaining accurate records of all transactions and activities. It emphasizes that this is crucial for ensuring transparency and accountability in the organization's operations.

2. The second part of the document outlines the various methods and tools used to collect and analyze data. It highlights the need for consistent data collection procedures and the use of advanced analytical techniques to derive meaningful insights from the data.

3. The third part of the document focuses on the role of technology in data management and analysis. It discusses how modern software solutions can streamline data collection, storage, and processing, thereby improving efficiency and accuracy.

4. The fourth part of the document addresses the challenges associated with data management, such as data quality, security, and privacy. It provides strategies to mitigate these risks and ensure that the data remains reliable and secure throughout its lifecycle.

5. The fifth part of the document concludes by summarizing the key findings and recommendations. It stresses the importance of a data-driven approach in decision-making and the need for continuous monitoring and improvement of data management practices.

6. The sixth part of the document provides a detailed overview of the data collection process, including the identification of data sources, the design of data collection instruments, and the implementation of data collection protocols.

7. The seventh part of the document discusses the various methods used for data analysis, such as descriptive statistics, inferential statistics, and regression analysis. It explains how these methods are applied to interpret the data and identify trends and patterns.

8. The eighth part of the document provides a comprehensive review of the data management system, including the hardware, software, and personnel involved. It also discusses the system's performance and the steps taken to optimize its efficiency.

APPENDIX C

EVALUATION QUESTIONNAIRE

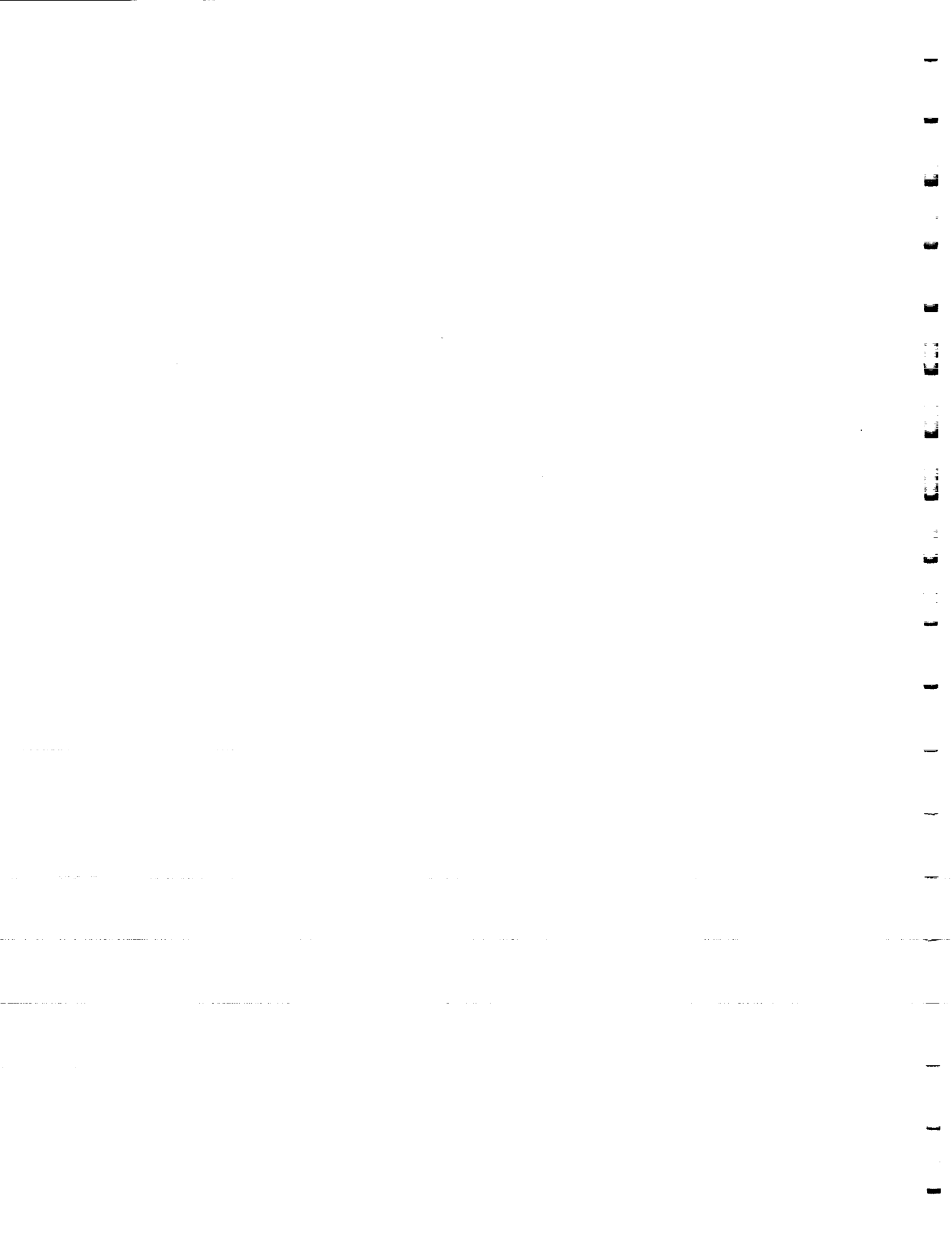



**AMERICAN SOCIETY FOR ENGINEERING EDUCATION**

**NASA/ASEE Summer Faculty Fellowship Program**

**Evaluation Questionnaire**

(Faculty Fellows should respond to the following questions)

Name: \_\_\_\_\_

Birthdate: \_\_\_\_\_

Social Security Number: \_\_\_\_\_

Permanent Mailing Address: \_\_\_\_\_

\_\_\_\_\_

\_\_\_\_\_

\_\_\_\_\_

Home Institution: \_\_\_\_\_

NASA Center and (Laboratory) Division: \_\_\_\_\_

\_\_\_\_\_

Name of Research Associate: \_\_\_\_\_

Brief Descriptive Title of Research Topic: \_\_\_\_\_

\_\_\_\_\_

## A. PROGRAM OBJECTIVES

1. Are you thoroughly familiar with the research objectives of the research (laboratory) division you worked with this summer?

Yes \_\_\_\_\_

No \_\_\_\_\_

2. Do you feel that you were engaged in research of importance to your Center and to NASA?

Yes \_\_\_\_\_

No \_\_\_\_\_

3. Is it probable that you will have a continuing research relationship with the research (laboratory) division that you worked with this summer?

Yes \_\_\_\_\_

No \_\_\_\_\_

Uncertain \_\_\_\_\_

4. My research colleague and I have discussed follow-up work including preparation of a proposal to support future studies at my home institution, or at a NASA laboratory.

Yes \_\_\_\_\_

No \_\_\_\_\_

5. Are you interested in maintaining a continuing research relationship with the research (laboratory) division that you worked with this summer?

Yes \_\_\_\_\_ No \_\_\_\_\_

## B. PERSONAL PROFESSIONAL DEVELOPMENT

1. To what extent do you think your research interests and capabilities have been affected by this summer's experience? (You may check more than one)

Reinvigorated \_\_\_\_\_

Redirected \_\_\_\_\_

Advanced \_\_\_\_\_

Barely maintained \_\_\_\_\_

Unaffected \_\_\_\_\_

2. How strongly would you recommend this program to your faculty colleagues as a favorable means of advancing their personal professional development as researchers and teachers?

Positively \_\_\_\_\_

Not at all \_\_\_\_\_

3. How will this experience affect your teaching in ways that will be valuable to your students? (You may check more than one)

By integrating new information into courses \_\_\_\_\_

By starting new courses \_\_\_\_\_

By sharing research experiences \_\_\_\_\_

By revealing opportunities for future employment in government agencies \_\_\_\_\_

By deepening your own grasp and enthusiasm \_\_\_\_\_

Will affect my teaching little, if at all \_\_\_\_\_

4. Do you have reason to believe that those in your institution who make decisions on promotion and tenure will give you credit for selection and participation in this highly competitive national program?

Yes \_\_\_\_\_

No \_\_\_\_\_

### C. ADMINISTRATION

1. How did you learn about the Program? (Please check appropriate response)

Received announcement in the mail.

Read about it in a professional publication.

Heard about it from a colleague.

Other (explain). \_\_\_\_\_  
\_\_\_\_\_  
\_\_\_\_\_

2. Did you also apply to other summer faculty programs?

Yes                       No

DOE

Another NASA Center

Air Force

Army

Navy

3. Did you receive an additional offer of appointment from one or more of the above?  
If so, please indicate from which.    Yes     No

\_\_\_\_\_

4. Did you develop new areas of research interest as a result of your interaction with your Center and laboratory colleagues?

Many

A few

None

5. Would the amount of the stipend (\$1,000 per week) be a factor in your returning as an ASEE Fellow next summer?

Yes \_\_\_\_\_

No \_\_\_\_\_

If not, why? \_\_\_\_\_  
\_\_\_\_\_

6. Did you receive any informal or formal instructions about submission of research proposals to continue your research at your home institution?

Yes \_\_\_\_\_

No \_\_\_\_\_

7. Was the housing and programmatic information supplied prior to the start of this summer's program adequate for your needs?

Yes \_\_\_\_\_

No \_\_\_\_\_

8. Was the contact with your research colleague prior to the start of the program adequate?

Yes \_\_\_\_\_

No \_\_\_\_\_

9. How do you rate the seminar program?

\_\_\_\_\_ Excellent

\_\_\_\_\_ Good

\_\_\_\_\_ Fair

\_\_\_\_\_ Poor

10. In terms of the activities that were related to your research assignment, how would you describe them on the following scale?

Check one per activity	Time Was:
------------------------	-----------

Activity	Adequate	Too Brief	Excessive	Ideal
Research				
Lectures				
Tours				
Social/Rec.				
Meetings				

11. What is your overall evaluation of the program?

- Excellent
- Fair
- Poor

12. If you can, please identify one or two significant steps to improve the program.

---



---



---

13. For second-year Fellows only. Please use this space for suggestions on improving the second year.

---



---

#### D. STIPENDS

1. To assist us in planning for appropriate stipends in the future would you indicate your salary at your home institution.

\$ \_\_\_\_\_ per Academic year \_\_\_\_\_ or Full year \_\_\_\_\_. (check one)

2. Is the amount of the stipend a primary motivator to your participation in the ASEE Summer Faculty Fellowship Program?

Yes \_\_\_\_\_ No \_\_\_\_\_ In part \_\_\_\_\_

3. What, in your opinion, is an adequate stipend for the ten-week program during the summer of 1995?

\$ \_\_\_\_\_

#### E. AMERICAN SOCIETY FOR ENGINEERING EDUCATION (ASEE) MEMBERSHIP INFORMATION

1. Are you currently a member of the American Society for Engineering Education?

Yes \_\_\_\_\_ No \_\_\_\_\_

2. Would you like to receive information pertaining to membership in the ASEE?

Yes \_\_\_\_\_ No \_\_\_\_\_

