

Final

IN-20-CR  
085102

NASA/CR-1998- 207731

"Antiproton Trapping for Advanced Space Propulsion Applications"

Summary of Research

Gerald A. Smith (Principal Investigator)

Grant Period: Feb. 1, 1997-Jan. 31, 1998

Laboratory for Elementary Particle Science  
Department of Physics  
303 Osmond Laboratory  
Pennsylvania State University  
University Park, PA 16802

Grant # ~~NAG8-1321~~

Grants Officer: Mark R. Stiles

Technical Officer: Dr. William Emrich, Jr.  
Marshall Space Flight Center, AL 35812

## Summary of Research

The Summary of Research parallels the Statement of Work (Appendix I) submitted with the proposal, and funded effective Feb. 1, 1997 for one year.

### I. ATHENA Experiment (CERN, Geneva, Switzerland)

A proposal was submitted to CERN in October, 1996 to carry out an experiment on the synthesis and study of fundamental properties of atomic antihydrogen. Since confined atomic antihydrogen is potentially the most powerful and elegant source of propulsion energy known, its confinement and properties are of great interest to the space propulsion community. Appendix II includes an article published in the technical magazine Compressed Air, June 1997, which describes CERN antiproton facilities, and ATHENA (see p.52, The Next Step) specifically.

During the period of this grant, Prof. Michael Holzschneider served as spokesman for ATHENA and, in collaboration with Prof. Gerald Smith, worked on the development of the antiproton confinement trap, which is an important part of the ATHENA experiment. Appendix III includes a progress report submitted to CERN on March 12, 1997 concerning development of the ATHENA detector. Section 4.1 reviews technical responsibilities within the ATHENA collaboration, including the Antiproton System, headed by Prof. Holzschneider.

The collaboration was advised (see Appendix IV) on June 13, 1997 that the CERN Research Board had approved ATHENA for operation at the new Antiproton Decelerator (AD), presently under construction. First antiproton beams are expected to be delivered to experiments in about one year.

Progress toward assembly of the ATHENA detector and initial testing expected in 1999 has been excellent. Appendix V includes a copy of the minutes of the most recently documented collaboration meeting held at CERN of October 24, 1997, which provides more information on development of systems, including the antiproton trapping apparatus.

On February 10, 1998 Prof. Smith gave a 3 hour lecture on the Physics of Antimatter, as part of the Physics for the Third Millennium Lecture Series held at MSFC. Included in Appendix VI are notes and graphs presented on the ATHENA experiment.

## II. Portable Antiproton Trap

A portable antiproton trap has been under development at Penn State since 1996. Serious testing has taken place since mid-1997. The goal of this project is to store and transport antiprotons from a production site, such as Fermilab near Chicago, to a distant site, such as Huntsville, AL, thus demonstrating the portability of antiprotons.

Detailed information on results from testing may be found in Appendix VI. Summarizing, based on electron and hydrogen ion trapping, we have concluded that the vacuum in the inner trap is currently  $10^{-10}$  torr. Based on our data from CERN experiment PS200 (precursor to ATHENA) and recently published theoretical cross sections for antiproton annihilation on cold residual gas, we estimate that this vacuum could support antiproton lifetimes of about 14 hours.

In the next few months, we expect to extent the vacuum downward by about a factor of 5, thus increasing lifetimes to about 70 hours, or 3 days, which meets design criteria. We also plan to inject large numbers of hydrogen ions into the inner trap, in order to test space charge limits, which are expected to be about  $10^9$ /cc. Since the trap volume is 10 cc, the design specification for a full load of antiprotons is  $10^{10}$ .

Once the trap has been filled to near-capacity with hydrogen ions, we will carry out a portability test, first around the Penn State campus and then to a more remote site by motor vehicle. This test requires the integration of stand-alone DC generating batteries into the electrical system of the trap.

If all of the above tests are successful, we will start preparing for a fill of antiprotons at Fermilab. A NASA SBIR Phase I project recently approved for Synergistic Technologies, Inc. of Los Alamos, NM will design an antiproton degrader and accumulator for this purpose. A successful Phase II activity would plan to have antiprotons ready for transfer to the portable trap in late 1999 or early 2000.

## Appendix I

## I. STATEMENT OF WORK FOR THE PERIOD FEB.1,1997-JAN.31,1998

We propose to carry out a detailed and comprehensive program of research in trapping of antiprotons at CERN in Geneva, Switzerland, and Pennsylvania State University in University Park, PA. The grantee, through partial support of Professor Michael H. Holzschneider and Senior Scientist Raymond A. Lewis, will engage in the following tasks during the period Feb.1, 1997-Jan.31, 1998:

1. Design and fabricate an antiproton trap for the Apparatus for High precision Experiments on Neutral Antimatter (ATHENA) experiment at CERN, Geneva, Switzerland. The antiproton trap in ATHENA includes a cryogenic magnetic coil, conventional and cryogenic vacuum pumping apparatus, HV sources and controls, detection circuitry, electronic readout and computer controls.

Funds for equipment, supplies and other resources will be provided by CERN and/or other funding agencies. Including positron traps and their delivery systems, which will be provided by collaborators at the University of California, San Diego, ATHENA will produce approximately  $10^4$  neutral atomic antihydrogen atoms every 10 minutes, using antiprotons from the new Antiproton Decelerator (AD) facility at CERN.

ATHENA will serve as a prototype for a scaled-up version capable of producing and confining many orders of magnitude more antihydrogen atoms for space propulsion applications. This work will be done largely by Prof. Holzschneider and Dr. Lewis at CERN.

2. Continue tests of the portable antiproton trap at Penn State University, University Park, PA. This includes optimization of  $H^+$  stored yields and lifetimes to predicted values, e.g. at least  $10^4$   $H^+$  stored for at least 4 days. When these specifications are achieved, we will transport a load of  $H^+$  to a distant site by motor vehicle, in order to demonstrate portability, which is key to future space propulsion applications. This work will be done largely by Dr. Lewis, under the direction of Principal Investigator Prof. Gerald A. Smith, in University Park.

3. Prepare detailed written reports for MSFC as mutually agreed upon by the MSFC and the grantee, and travel to professional meetings to present such reports as needed.

During this period this work will received overall direction from Prof. Gerald A. Smith.

**Appendix II**

# Capturing Antimatter

by Jerome M. Rosen



**P**hysicists have embarked on an odyssey into the looking-glass universe of antimatter, where the particles that compose the universe still exist, except their charges are reversed. In such a backwards-charged realm, the antielectron carries a positive instead of negative charge.

In a fleeting debut lasting only a few billionths of a second, atoms of antihydrogen—the simplest antimatter atom—were painstakingly synthesized at a European laboratory in September 1995. Antihydrogen then put in a repeat appearance at a U.S. lab in November 1996.

And now that physicists have shown that they can synthesize antimatter, they are preparing devices to capture it the next time it winks into existence. If antihydrogen can be trapped and studied, it will give physicists a tool with which to test the fundamental assumptions about our physical world—tests that could shake the foundations of modern physics. Antihydrogen also could be a tool for exploring the possibility that our universe may include entire antigalaxies consisting of antimatter worlds. Trapping antimatter may even lead to the development of a powerful new energy source, one that could fuel humanity's exploration of the stars.

## What's Antimatter?

Physicists have been smashing atomic particles together with increasing amounts of energy for decades. In the wreckage of these collisions, they have observed hundreds of previously unknown elementary particles. These ele-

**Scientists around the world are busy designing elaborate traps.**

**Their quarry?**

**Elusive antimatter.**

mentary particles are the building blocks of matter. Half of these new particles belong to the very special realm of antimatter, where all the physical properties *appear* to be the same, except the charges of the particles are reversed.

A fundamental rule of modern physics says that for every type of elementary particle in nature there is a corresponding antiparticle—the exception being the photon, which is its own antiparticle. Matter and antimatter are antagonists and cannot coexist at close range for more than a small fraction of a second. When they meet, their charges cancel and their masses are converted into pure radiant energy—either in a single step or a cascade of steps—and both are annihilated. Because antimatter annihilates so readily here on Earth, it is seen only when it is artificially generated in high-energy particle accelerators, such as those at CERN, the European center for particle physics in Geneva, Switzerland, or at Fermilab (Fermi National Accelerator Laboratory) in Batavia, IL. Naturally occurring antimatter has

## Low-Energy Antiproton Ring (LEAR)

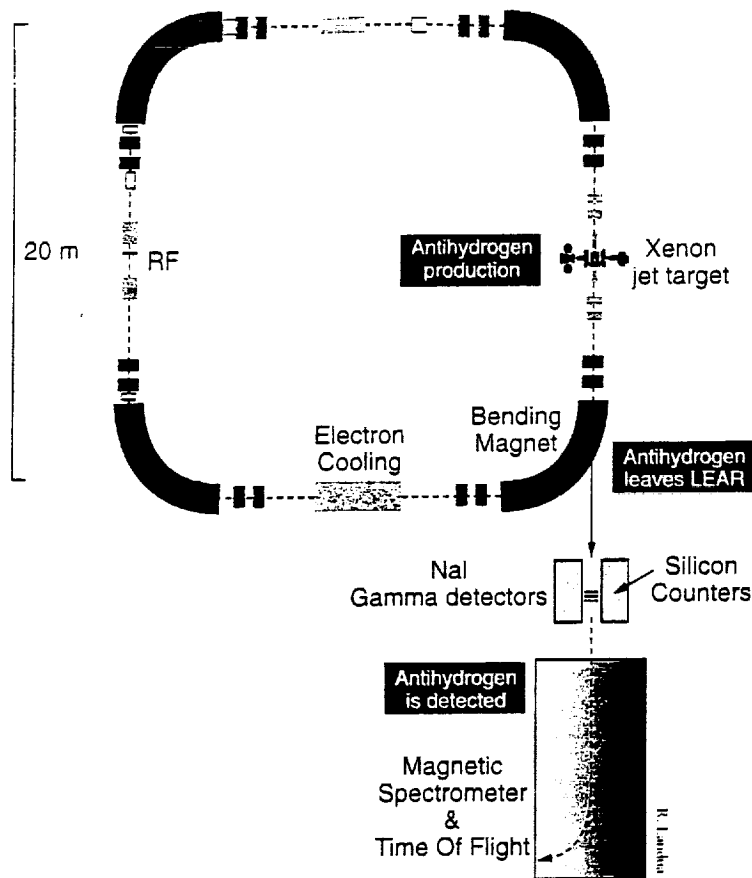

The production and detection scheme for the first CERN experiment that produced antihydrogen.

been observed in collisions between cosmic rays and atoms within Earth's atmosphere, and its presence was discovered in this way in 1932.

### The First Step: CERN and Fermilab Experiments

As in ordinary atoms, where electrons are captured in orbit around an atomic nucleus, the recipe for antihydrogen is very simple: take 1 antiproton and bring 1 antielectron close enough so that it can be put into orbit around the antiproton. But making antiprotons is an extremely slow and very expensive process. In the accelerator smashings that produce antiparticles, only about one antiparticle in a million is an antiproton.

In September 1995, a team of German, Italian, and Swiss physicists used the Low-Energy Antiproton Ring (LEAR) at CERN to synthesize antihydrogen. For some 15 hours, the physicists fired a jet of xenon atoms across

LEAR's antiproton beam. Most of the antiprotons passed through the jet unaffected. On rare occasions, an antiproton interacted with a xenon nucleus and created an antielectron, also called a positron, in the strong electric field of the nucleus. In even rarer cases, the created positron was moving in exactly the right direction and with just the right speed to be captured by a passing antiproton, forming an atom of antihydrogen.

Once formed, the antihydrogen had no net charge and was free of the grip of LEAR's powerful bending magnets. The antihydrogen then traveled 10 meters from the interaction region before colliding with a detector that stripped down its component antiparticles, which subsequently vanished in a telltale burst of energy. At CERN, antihydrogen's debut lasted 38 nanoseconds (billionths of a second). Of the 300,000 particles that hit the detector, 11 had the signature expected of antihydrogen.



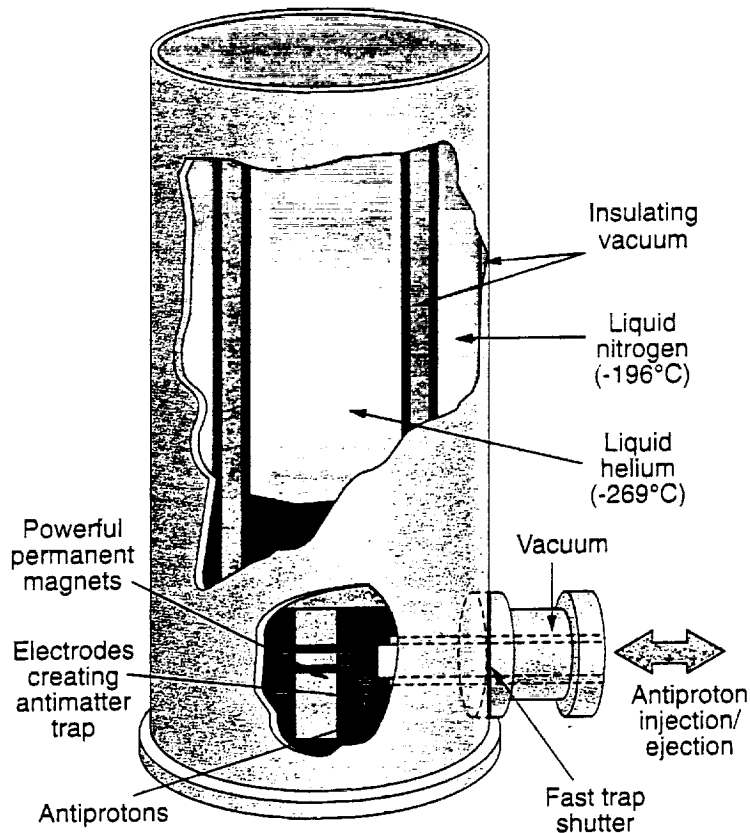

G.A. Smith, The Pennsylvania State University

Scientists at Penn State have designed a portable antimatter trap, which they think could confine antiparticles for up to 10 days. The trap will have a very high vacuum—only 100 air molecules per cubic centimeter. Liquid helium insulation in the walls of the trap will maintain an interior temperature only a few degrees above absolute zero. Magnetic and electric fields will keep antiparticles away from the walls, confining them in a circular orbit within the container.

About a year later, a team of Fermilab and University of California, at Irvine, physicists successfully repeated the CERN experiment.

### The Next Step

Initially, there was a flash of excitement about the production of antihydrogen. But physicists quickly concluded that the method used by CERN and Fermilab to make antihydrogen has serious flaws. Michael Holzschteier, a physicist at Los Alamos National Laboratory, Los Alamos, NM, and The Pennsylvania State University, University Park, PA, describes the flaws of the production method: "It is not only inefficient, but makes antihydrogen in the wrong environment for precision measurements or further applications, because they [the antiatoms] are moving so fast and annihilate in a few nanoseconds."

To remedy these problems, two research collaborations—one called ATHENA (Apparatus for High precision Experiments on Neutral Antimatter) and the other ATRAP (Anti-

hydrogen TRAP)—propose a difficult and ambitious undertaking: They will attempt to make antihydrogen at low velocities at CERN. To control the constituent particles and antihydrogen atoms, they propose to use a combination of electric and magnetic forces to form a "magnetic bottle." They then plan to use cryogenics to supercool the bottles to slow down the antihydrogen atoms they hope to trap inside.

At present, Fermilab is not suited for trapping antihydrogen. As Gerald Smith, a member of the ATHENA team and a professor of physics and director of the Laboratory for Elementary Particle Science at The Pennsylvania State University, explains, "Fermilab doesn't have anything like the Low-Energy Antiproton Ring, which essentially decelerates antiprotons to an energy where they can be put into our traps easily. We're working on Fermilab to do that."

The main difference between the two approaches is the process used for combining the antiparticles. ATRAP will accumulate a

cloud of antiprotons in one part of an electromagnetic trap, known as a Penning trap, and a cloud of positrons in another part of the trap. The clouds then will be brought together in the middle, where they will combine by collisions to make a shower of antihydrogen atoms. An advantage of the ATRAP design is that it can very precisely control the motion of the charged particles. Just before the end of last year, the ATRAP team was able to use LEAR to put antiprotons and positrons together in the same trap for the first time.

"It's a significant step," says Gerald Gabrielse, a professor of physics at Harvard University, Cambridge, MA, and the spokesperson for ATRAP. "We didn't make any antihydrogen, but we did discover some new challenges that we have to solve."

In ATHENA, the philosophy is to separate the stages of antiproton and positron accumu-

lation into separate traps. The collected antiprotons and positrons then would be injected from opposite sides into the middle of a superconducting magnet. The particles would be combined through manipulation of adjustable fields in the middle of the magnetic bottle. Theoretical calculations indicate that as many as 10,000 antihydrogen atoms may be formed within seconds. However, the trick of how to hold on to both the antiprotons and positrons, and then the newly formed antihydrogens, is still being worked out by the ATHENA team.

Both approaches are expected to be approved. CERN looks positively on having two competing groups, because it increases the number of bases covered, and because the competition increases the intensity of the work.

A major problem facing both teams is that LEAR has been shut down for budgetary rea-

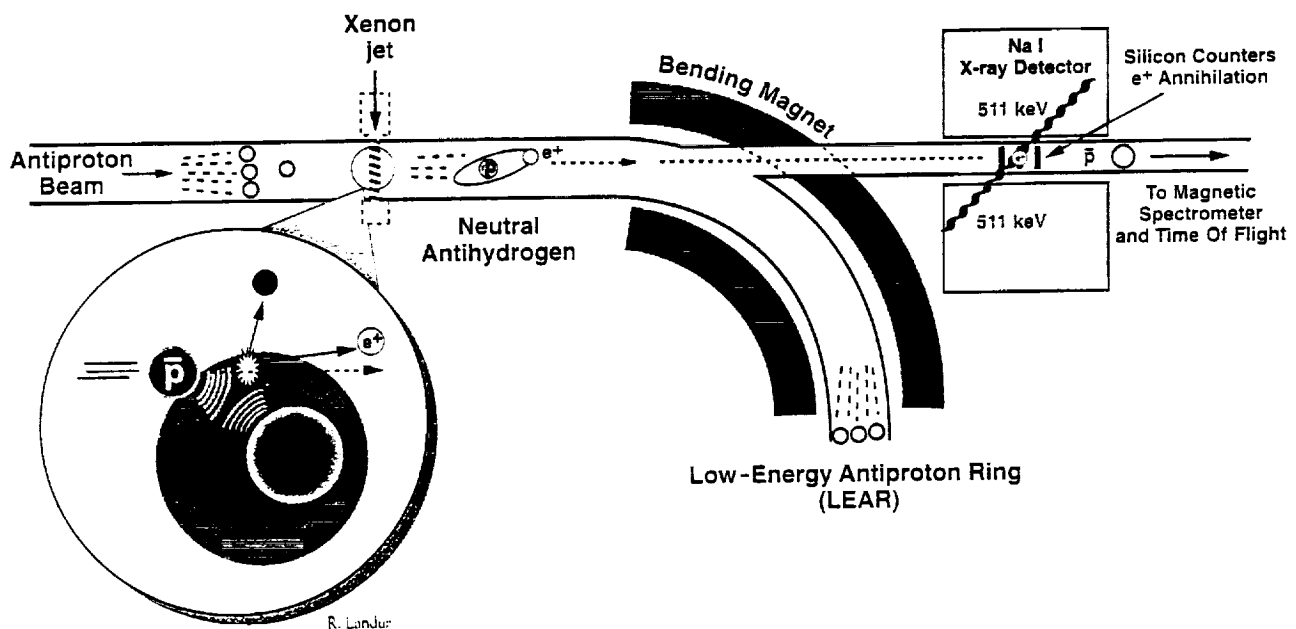

To produce antihydrogen in flight, a jet of xenon atoms is fired across LEAR's antiproton beam. The short-lived antihydrogen formed in the collisions are free of LEAR's bending magnet and crash into detectors, which note the resulting byproducts of the destroyed antihydrogen.



## Antimatter and Cosmology

One of the most important and formidable questions in natural science is, "How did the universe begin?" Many attempts have been made to investigate the importance of antimatter in the cosmological problems of understanding the creation and constitution of the universe.

In the Big Bang model of creation, energy converted into particles and antiparticles in the early universe; and there should have been just as much antimatter as matter. If the laws of physics apply to the universe in general, then the symmetry of antimatter-matter forces us to consider the existence of antiworlds and antigalaxies. In the book *World's-Antiworlds: Antimatter in Cosmology*, the recently deceased Swedish astrophysicist and Nobel laureate Hannes Alfvén suggested: "It is even possible that every second star in our own galaxy may be an

antistar." And if there are antistars, there also may be antiplanets with antibeings on them.

No present understanding of the evolution of the universe adequately explains the unmixing of matter and antimatter that occurred. Because of the scarcity of observed antiparticles, a number of scientists believe there was an imbalance in their relative amounts in the early universe, which ultimately favored particles at the expense of antiparticles. They attribute the imbalance to a very slight difference in the decay properties of matter and antimatter, which has been noted in experiments at CERN and Fermilab. As the universe aged and cooled, the very slight excess of matter over antimatter—about one part in a billion—became significant. Otherwise, had the opposing amounts balanced, everything would have annihilated right at the beginning.

There also is the possibility that a slight difference in gravity caused particles of matter and antimatter to behave differently, which caused them to migrate to different regions in the universe or even to different universes.

With current technology, we are able to directly observe only a very small percentage of the total mass of the universe. In the search for extraterrestrial antimatter, distinct signatures have yet to be found.

Because the existence of antiprotons and positrons in and above the Earth's atmosphere are a natural result of the violent collisions between cosmic background radiation and atmospheric interstellar particles, these antiparticles are not conclusive evidence of the existence of antimatter from antisolar systems. Taking another approach, astronomers have looked for 20 years in space for a boundary of matter and antimatter, because it might show a characteristic radiation produced by matter and antimatter annihilating each other. But they have found nothing so far.

Recently, Nobel laureate physicist Samuel Ting, of the Massachusetts Institute of Technology, Cambridge, MA, initiated a hunt for antielements, such as antioxygen and anticarbon, that only can be produced by an antisolar system either inside or outside our galaxy. In May 1998, a space shuttle is scheduled to place into orbit an antimatter detector designed by an international team of scientists. The device, called the alpha magnetic spectrometer, or AMS, consists of a giant permanent magnet that would deflect charged particles to detectors. If AMS detects the heavier antimatter elements, it will be indisputable evidence that antimatter exists outside our galaxy or somewhere within our galaxy.

sons. (LEAR was a complicated machine to operate, and required three other machines to do the four different functions of collecting, cooling, decelerating, and extracting antiprotons. Maintenance alone took 45 man-years each year.) CERN has closed down nearly all its programs in order to get the financial and manpower resources in place for the \$2.25 billion

Large Hadron Collider program, which is to be ready by 2005. After all, the main mission of CERN and Fermilab is not antihydrogen production, but to probe as deeply as possible the recesses of how particles are put together. The ATHENA and ATRAP teams requested that a portion of LEAR's antiproton source be converted, at a cost of \$5 million, into a combined

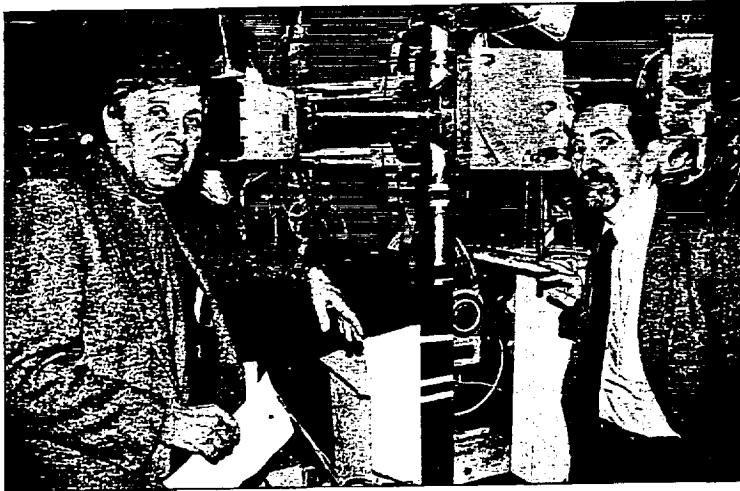

Team leader Walter Oelert (right), of the 22-member CERN group that produced the first handful of antihydrogen atoms, stands beside the antihydrogen detector. On the left is team member Mario Macri.

antiproton production and decelerator machine useful for antihydrogen production and spectroscopy.

Recently, funding for the conversion was obtained, and in early 1999 the Antiproton Decelerator will be ready at CERN. By mid-1999, there should be enough cold antimatter at hand to make measurements. Until then, the ATHENA and ATRAP teams will test their equipment on matter particles, given that matter and antimatter are very much alike in properties.

### Checking the Foundations of Modern Physics

When the ATHENA and ATRAP teams measure the cold antimatter they have collected, they also will be testing our understanding of the laws of nature. Los Alamos' Holzscheiter, who also is the spokesperson for ATHENA, says, "If you get a clear measurement, you can start disproving theories, or give guidance on what theories hold up and which should be looked at more carefully."

Many physicists believe we do understand the fundamentals of physics and the universe through a model known as the Standard Model. One consequence of the Standard Model is that

each law of nature is automatically symmetrical (the same) if the charge, the parity (a type of mirror image in which the particle direction is reversed), and the arrow of time are simultaneously inverted. This very fundamental symmetry is known as CPT (charge, parity, time), and it requires that matter and antimatter *must* have the same properties.

The CPT symmetry has proven true—so far. "But," says Holzscheiter, "there is something uneasy about the whole thing, because gravity just doesn't fit in with the other forces—the electromagnetic strong and weak forces. And when people try to unify everything into the Grand Unification theory, there are a lot of unanswered questions."

To shed light on CPT symmetry beyond the current level of precision, a neutral particle is needed to do precision spectroscopy. Physicists see antihydrogen as the simplest system, and the very best way to test CPT symmetry. Another benefit of testing antihydrogen is that its matter counterpart, hydrogen, has been tested very precisely already. The goal is to study single antihydrogen atoms and compare them to single hydrogen atoms, to see if they are equal. If a positron is attracted by the antiproton with exactly the same force that an electron is

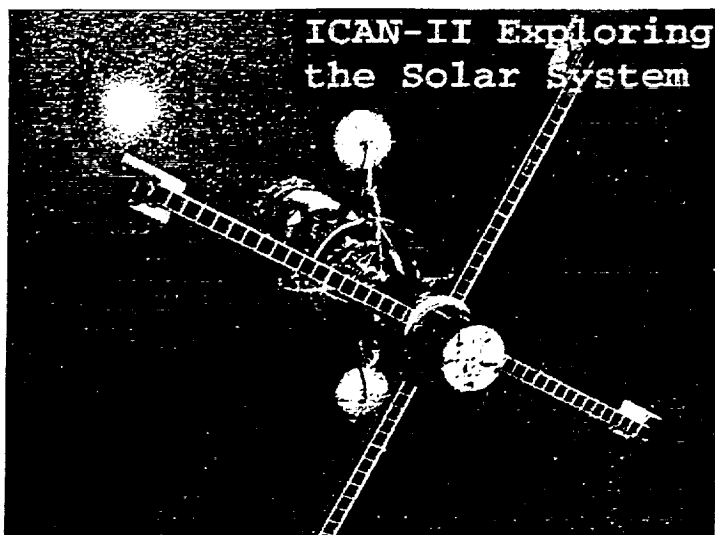

The Pennsylvania State University

Artist's conception of the ACMF (antiproton catalyzed microfission/fusion) powered spacecraft named ICAN-II (Ion Compressed Antimatter Nuclear).

attracted by a proton, then the positron should orbit the antiproton in a manner similar to how an electron orbits a proton. Therefore, a shift from one orbital state to another by the antihydrogen should emit the very same spectral line as that of ordinary hydrogen. "If the experiments we'll do at CERN to make antihydrogen work," says Smith of Penn State, "we will hit these atoms with lasers, excite them, and watch them decay."

If it turns out that the spectra produced by this event are different, Holzscheiter says, "It would be proof that one has to go beyond the current theory with new ideas of how the universe would be built. It really touches on the very foundation of our current understanding of physics. It would be a growing process, just like Einstein's relativity expanded on Newton's laws, and Newton on Galileo, and back to the beginning of scientific time. It just gives a clearer view of what's going on at the smallest level."

### Antimatter as a Power Source

Besides being used as tools to check the validity of current theories, antiprotons and antihydrogen also could be used for other applications. Because of the 100 percent conversion into energy when matter and antimatter meet, very small amounts of antimatter could produce very large amounts of energy.

Conceivably, an antimatter fueled power source could be very compact, and very powerful. However, Holzscheiter does not see this happening with our current technology or understanding of physics. "What is needed are fundamentally new ideas on how to handle it [antimatter], how to convert it into energy, how to use it," he says.

However, plans already are being formulated to use antiprotons in space propulsion systems. One of the early U.S. space shuttle astronauts, Ernst Messerschmidt of the Space Research Institute in Stuttgart, Germany, is pursuing the use of antiprotons as a heating agent for a plasma drive. Antiprotons would be injected into a cloud of charged particles (a plasma) confined by a magnetic field. The interaction between the antimatter and matter would generate an increased temperature, which converts to an output of energy for space applications. Messerschmidt is ready to set up a small experiment at CERN, as soon as the antiproton beam becomes available, to see how efficiently the process works.

Another propulsion scheme, antiproton catalyzed microfission/fusion (ACMF), has been proposed by Smith of Penn State, and others. ACMF involves putting short bursts of antiprotons into a fissionable material (e.g., uranium). The induced temperature increase would be high enough to induce ignition of a hydrogen fusion burn within a microcapsule. (A microcapsule is about the size of a BB, and contains hydrogen as a high-pressure gas or liquid. Microcapsules are used in fusion research.) For a 130-day round trip to Mars—with a 30-day stay—Smith figures ACMF would require about a microgram of antiprotons or antihydrogen—about a year's production of antiprotons at Fermilab. The cost of the antimatter would be about \$50 million, he says. A spacecraft has

been designed around an ACMF engine, and a demonstration of ACMF is planned.

The key question for any application dreamed up by scientists is what amount of antimatter will be needed? According to Rolf Landua, a physicist at CERN and a member of the ATHENA team, "It is quite absurd right now to talk about macroscopic applications, because all the antimatter that has been produced in the past 10 years at CERN is about one nanogram [a billionth of a gram]." He estimates that to produce a milligram with CERN's present technology would take about a million years and cost about \$100 trillion (without inflation). However, Smith of Penn State points out that with new technology, producing a milligram of antimatter would take "about 10 years and cost \$1 to \$2 billion."

## **Expect the Unexpected**

"It is always difficult to predict what will happen at a frontier just beginning to be explored," says Gabrielse of Harvard University. "Often in the pursuit of basic physics goals, just learning how things are put together, we push reality and technology so hard that unexpected things pop out." In this particular odyssey, the next few years of research into antimatter may unveil the need for rethinking how the universe is built and our place in it.

### **For More Information**

To learn more about antimatter, visit this article on the *Compressed Air* home page: <http://www.ingersoll-rand.com/compair> CA

**Appendix III**

CERN / SPSLC 97-9  
SPSLC/M597  
March 12, 1997

Memorandum to the SPSLC

Progress report on the design  
of the ATHENA apparatus

The ATHENA Collaboration



# 1 Introduction

The following memorandum describes specific design choices which have been made by our collaboration. These choices address all questions and comments of the referee which were sent to the ATHENA collaboration on 27 November 1996.

## 2 Overview

The goal of the first stage of the ATHENA experiment is to produce and to trap antihydrogen atoms, and to perform a laser-spectroscopic measurement of the energy difference between the atomic 1S-2S level, with a precision comparable to the present accuracy for hydrogen atoms. For that purpose, we have chosen the most promising and straightforward technologies from the present point of view. Alternative routes to antihydrogen exist, but will not be pursued unless the need arises. In brief, the main design choices are the following:

- Independent high-rate accumulation of antiprotons and positrons:
  - 1) Two separate, optimized accumulation schemes allow accumulation and cooling of  $10^7$  antiprotons and  $10^{10}$  positrons per hour, which is several orders of magnitude higher than alternative schemes.
  - 2) Independent accumulation of antiprotons and positrons does not interfere with the recombination and spectroscopy part of the experiment.
- New Positron Accumulator:

The positron accumulator will be based on the buffer gas moderation scheme pioneered by Cliff Surko and coworkers. A new improved apparatus will be built, and become part of the ATHENA apparatus until the completion of the experiment.

- Spontaneous Radiative Recombination Scheme:

The antihydrogen recombination scheme is based on overlapping plasmas of antiprotons and positrons in nested Penning traps. Spontaneous radiative recombination at cryogenic temperature is expected to produce thousands of antihydrogen atoms per second in low- $n$  states, assuming fully overlapping clouds of  $10^7$  antiprotons and  $10^8$  positrons. These rates are derived from proton-electron recombination measurements in cooled proton storage rings. The rate for three-body recombination (simultaneous collision of one antiproton and two positrons) is potentially even higher, but has the disadvantage of producing antihydrogen in very high- $n$  Rydberg states, which are likely to re-ionise before reaching a stable low- $n$  level. Laser-stimulation can be used to enhance the rate by about two orders of magnitude, but is not considered necessary at this stage of the experiment.

- Integrated Magnet Design:

A new, custom-designed superconducting magnet will be used. It will accommodate two solenoid regions (for the antiproton and positron capture and cooling traps) and one central quadrupole region, producing the magnetic confinement field for neutral antihydrogen atoms. The all-in-one design offers the advantage of trap-to-trap transfer in a continuous magnetic field arrangement and within the same ultra-high vacuum and cryogenic environment. The quadrupole field will allow trapping antihydrogen atoms with kinetic energies below 350 mK. Even with a small number of trapped antihydrogen atoms, spectroscopic measurements will be possible.

- Dilution Refrigerator Cooling:

A cooling system connected to a He-3 dilution refrigerator will allow cooling of the positron, the antiproton, and the recombination section to 100 mK temperature. In the first stage of the experiment, for the purpose of investigating production rates and testing the antihydrogen detector, a simpler operation mode using only the He-4 cooling of the dilution refrigerator is envisaged.

- Laser Spectroscopy:

Two-photon spectroscopy of antihydrogen will be done using a 100 mW, 243 nm laser system. The recombination trap will be situated between two mirrors, located at the respective positron and antiproton sides of the apparatus (see Fig. 1). The laser system will be located on a vibration-free support in order to achieve a line width of a few kHz. The windows will absorb less than 10% of the laser power. We do not presently foresee the use of 121 nm laser cooling, nor of an infrared laser system to stimulate antihydrogen recombination.

- Measurement of 1S-2S Transition:

We recall that only antihydrogen atoms of a given spin direction with respect to the quadrupole field orientation are trapped by a magnetic bottle. When the laser is adjusted to the resonance, antihydrogen is excited to the long-lived (121 ms) 2S state. By using a short electric pulse of e.g. 1 ms length, a 2S-2P transition is induced, from where the atom rapidly (1 ns) de-excites back to the 1S level. However, during this process the spin orientation of half the antihydrogen sample is flipped. These 'high-field seeking' atoms are accelerated towards the quadrupole coils, annihilating at the wall of the recombination trap within less than 1 ms. Therefore, the antihydrogen 1S-2S resonance line is obtained by counting the number of annihilations within a few millisecond time interval after the quench pulse. This method should provide a practically background-free signal with a very high detection efficiency.

## 3 Description of the ATHENA Apparatus

### 3.1 Positron Accumulator

The overall aim is to produce a versatile source of low-energy positrons capable of providing ATHENA with positrons at a rate of  $10^{10}$  per hour, either in a single burst once per hour or in multiple bursts as required. The system is based upon proven low-energy positron beam technology and the trapping techniques developed by the UCSD group.

A fraction of the positrons emitted from a 150mCi (5.6GBq)  $^{22}\text{Na}$  source is slowed to kinetic energies of a few electron volts and emitted into vacuum using a solid neon moderator arrangement [1]. This system was developed at UCSD specifically for use with the positron accumulator and optimised to work in that environment. The overall efficiency of moderation is  $\sim 0.7\%$ , which results in a slow positron beam of approximately  $2.5 \times 10^7 e^+ s^{-1}$ . This beam is transported to the trapping region, illustrated in Fig. 1 of the original proposal, using a 2 m long, narrow-bore, bent solenoid. This arrangement serves two purposes:

- to remove the trap and the rest of the ATHENA apparatus from direct line-of-sight of the radioactive source, allowing efficient shielding of the antihydrogen detector from the  $\gamma$  radiation from the positron source, and
- to ensure, by virtue of the narrow interconnecting bore and the pumping provided, that the moderator is unaffected by the presence of the buffer gas in the accumulation region.

Positrons are accumulated in a Penning trap type arrangement using energy loss in a buffer gas. As described in Ref. [2], the trap has three stages created in a specially designed electrode structure. Each stage has successively lower gas pressure, created by differential pumping, and successively lower electrostatic potential. Positrons entering the trap lose energy by collisions with the buffer gas, and they become trapped and cooled in the lowest pressure region (i.e.,  $5 \times 10^{-7}$  torr) in less than one second. As shown in Fig. 2, in the present trap,  $10^8$  positrons can be accumulated from a 60 mCi source in a period of around 100 s [2].

The expected performance of the positron accumulator for the ATHENA experiment is summarized in Table 3.1. The radioactive source will be at least a factor of two more efficient (per unit source strength) in producing positrons and it will be about a factor of 2.5 stronger, so that the number of positrons per accumulation cycle will be a factor of five larger. The lifetime of the positrons in the present trap is approximately two hours when the nitrogen buffer gas pressure is reduced to  $5 \times 10^{-10}$  torr at the end of the accumulation cycle.

In order to reach the ATHENA design goal of  $10^{10}$  positrons accumulated per hour, an additional ultra-high vacuum (UHV) storage stage (pressure  $\sim 10^{-11}$  torr) will be added in which the positron lifetime is expected to be in excess of one day [3]. This UHV stage will be isolated from the positron trap and the antiproton and recombination traps by fast-acting gate valves. Every three minutes  $5 \times 10^8$  positrons can be shuttled into the UHV trap, resulting in an accumulation of  $1 \times 10^{10}$  positrons

accumulated per hour. The confining magnetic field, both in the UHV trap and in the accumulation trap, will be around 0.1 T and will be provided by conventional copper solenoids. Thus, there are no special cryogenic requirements for the magnets used by the positron apparatus.

As required, positrons at a temperature of 300 K in the UHV positron trap will be shuttled to the internal storage trap, which is at a field of 2.5 T and cryogenic temperature. This will be done by raising the potential of the UHV stage electrodes and by applying appropriate voltages on a series of electrodes between the two stages. Magnetic mirroring will not present a problem, since the initial perpendicular energy of the particles is small (i.e.,  $E_{\perp} \sim k_B T$ , where  $T = 300$  K). This method to transfer electrons from low magnetic field to high field has been tested successfully in two different experiments at UCSD [4].

Table 1: Current and expected positron accumulation parameters.

Parameter	Present	Expected
Source strength (mCi)	65	150
Source efficiency	20%	40% <sup>a</sup>
Positrons per cycle	$1 \times 10^8$	$5 \times 10^8$
Cycles per hour	20	20
Positrons per hour	$2 \times 10^9$	$1 \times 10^{10}$
Pressure (torr)	$3 \times 10^{-10}$	$< 5 \times 10^{-11}$
Density ( $\text{cm}^{-3}$ )	$\sim 2 \times 10^6$ <sup>b</sup>	$> 1 \times 10^9$ <sup>c</sup>

<sup>a</sup>Dupont Pharma reports current source efficiencies of 70%.

<sup>b</sup>One cycle in a 0.1 tesla field.

<sup>c</sup>One hour accumulation in a 3 tesla field.

## 3.2 Main Magnet System

The main magnet system contains the antiproton capture and cooling trap, the final positron storage trap, the recombination trap - superimposed by the neutral trap, and the detector for antihydrogen annihilation.

### 3.2.1 Charged particle traps

Antiprotons will be captured in a cylindrical Penning trap ( $L = 500$  mm,  $d = 20$  mm) situated in a homogeneous 2.5 T solenoid field with  $\Delta B/B = 1 \times 10^{-3}$ . A 200 ns long bunch of antiprotons with 5.8 MeV kinetic energy traverses a beam monitoring system and enters the trap structure through a variable pressure gas cell and a degrading foil of about 130 micron thickness. This foil will act at the same time as one of the high voltage electrodes of the trap. From simulations and experience gained in LEAR experiment PS200, a trapping efficiency of about 1 % is expected for a trapping voltage of  $\sim 15$  kV.

To rapidly cool the antiprotons with energies in the few keV range,  $\geq 10^8$  electrons must be loaded into the central part of the trap. Through synchrotron radiation these electrons rapidly cool to the ambient temperature and coalesce in the central well. The antiprotons oscillate through the cold electron cloud and lose their energy by Coulomb interaction. In ATHENA, electrons will be loaded into the trap using a field emission point, from which an electron beam will impinge onto the inside of the degrading foil. This beam releases atoms from this foil, which are ionized by subsequent electrons. These secondary electrons are captured in the trap, while the positive ions leave the trap rapidly.

Cold positrons are transferred from the second UHV stage of the positron accumulator to the final storage trap for positrons ( $L = 200$  mm,  $d = 20$  mm) located within the main magnet system. The UHV transport system will be isolated from the vacuum in the central trap system by a series of fast acting valves, thus reducing the gas load onto the extreme high vacuum ( $p \leq 10^{-12}$  torr) inside the cryogenic bore.

In the center between these two Penning traps a third trap ( $L = 150$  mm,  $d = 25$  mm) will be placed, consisting of a sequence of nine or more cylindrical electrodes forming an electrical potential along the axis capable of storing both cold positrons and cold antiprotons in close proximity. By manipulating the voltages on the different electrodes, the two clouds can be merged at low relative energy, allowing the antiprotons and positrons to recombine into antihydrogen. Due to the low kinetic energy ( $\sim$  milli-eV) of the particles, the requirements on the magnetic field strength in this region are much less stringent and the axial field value has been chosen to be 0.3 Tesla.

### 3.2.2 Particle Manipulations

Both the antiproton and the positron trap will consist of a sequence of cylindrical electrodes with lengths, and length-to-diameter ratios, optimized to form a harmonic trap potential over a subsection of the total trap length. These harmonic wells will be used to collect cold particles and to radially move and compress the stored particle clouds in preparation for the merging of the two species.

The particle clouds will be monitored and manipulated non-destructively using passive tuned circuits consisting of an inductive pick-up coil connected in parallel with the trap electrodes. This method avoids any heating stemming from an FET-based detection scheme.

The circuits will serve two main purposes:

(a) Detection of the total number and the average temperature of the particles.

The harmonic motion of the charged particles will induce currents in the trap electrodes. The amplitude of these currents is proportional to the number and the temperature of the particles. Resistive damping of these induced currents will enable cooling of the particle motion. A tank circuit formed by an inductor (connected from one end-cap to ground) and the end-cap capacitance, is tuned such that  $\omega_z^2 = 1/LC_{trap}$ . The current induced by the ion motion in the trap will be dropped across the enhanced impedance  $Z_{tank} = Q\omega L$ , generating significant signal amplitudes. On resonance, the impedance  $Z_{tank}$  becomes real and therefore damps the ion motion. Since we will be operating with large numbers of charged particles ( $\geq 10^6$ ), the need for extreme high Q circuits, requiring superconducting technologies, will not be

essential. It was shown by the PS200 collaboration that this technique works well for the detection of large number of particles. In this case the pre-amplifiers can be mounted externally to the 0.1 K environment, reducing the heat load onto the refrigerator.

(b) Provision of a good overlap between antiproton and positron clouds.

Only if the center of mass motion of the two clouds is centered along the same magnetic field line of the atom trap, a good overlap between the two plasma clouds is ensured. Centering will be achieved by compressing the magnetron motion of the particles, which is a slow collective motion around the central axis of the Penning trap due to the presence of ExB fields. The method of "sideband cooling" (exciting the axial motion by driving the particle motion at the sum of the cyclotron and the magnetron frequency) will reduce the magnetron radius as it will increase the axial amplitude. The increased axial energy will then be damped resistively through the tuned circuit. The rate of magnetron cooling will be limited only by the axial damping rate and the detuning from the resonance. In case that the axes of symmetry in the antiproton and positron sections do not coincide due to patch or asymmetric contact potentials the clouds can be moved in the radial direction (across the magnetic field lines) by applying an asymmetric voltage across opposing segments of the ring electrode split into four quadrants.

### 3.2.3 Transfer section

The design of the main magnet allows the trap-to-trap transfer to occur within a continuous magnetic field, avoiding problems with the adiabatic growth of the transverse size of the plasma clouds. Before the transfer, the particles will be centered in the traps so that they can follow the central magnet field line. This avoids significant magnetron orbital expansion or a magnet mirror effect leading to a growth of the longitudinal emittance during the transfer. The particles will be transferred between traps at energies well above typical patch-effect voltages that may occur on the extremely cold surfaces. To minimize heating of the particle during the transfer and re-capture process, a series of drift tubes and einzel lenses will be implemented. The inter-trap transfer of particles between traps was studied by PS200, and the experience gained will be incorporated into the ATHENA project.

### 3.2.4 Neutral atom trap

The confinement of neutral atoms is effected through the interaction of the atom's magnetic moment and the magnetic gradient. Because of the two possible directions of the magnetic moment in relation to the direction of the magnetic field, the produced atoms will separate into "low-field seeking" and "high-field seeking" species. The "low-field seeking" atoms can be confined in a magnetic field configuration with a field minimum at the center. (A zero magnetic field must be avoided since the atoms would undergo Majorana spin flips and change from trapped "low-field seekers" into unconfined "high-field seekers".)

The motion of the atoms in the magnetic field must be adiabatic (i.e. slow compared to the Larmor precession of the magnetic moment around the magnetic field

vector), otherwise spin flips would occur. Since this is the case for the ATHENA parameters, the magnetic moment will always be aligned with the total magnetic field vector and therefore the trap depth is given by the difference in total magnetic energy between the center of the recombination trap (where antiprotons and positrons are initially confined) and the boundary of the neutral trap, which is defined by the magnetic contour line (in the r-z plane)  $B_{max}$  which lies entirely inside all physical trap electrodes on which the antihydrogen atom could annihilate. The well depth of the trap is then given by the relation:

$$E_{kin} \leq \mu \times (B_{center} - B_{max}); \text{ where } B = B_{total} = \sqrt{B_r^2 + B_z^2}.$$

For one Bohr magnetron the well depth is about 0.7 Kelvin per Tesla, requiring a difference in total magnetic field strength of 0.5 Tesla to trap antihydrogen atoms at an initial energy of 350 mK ( $\sim 35 \mu\text{eV}$ ). The design of the central magnet will provide a well depth of at least 350 mK, using standard cryogenic methods (4.2 Kelvin liquid helium bath) and materials (NbTi superconductors).

### 3.2.5 Magnet design

The central magnet system has to match the following requirements:

Two sections of about 500 mm length with a homogeneous axial (solenoid) field of 2.5 T are needed for antiproton and positron capture and cooling. To confine the neutral antihydrogen atoms we need a central section with a radial magnetic well depth of least 0.5 T over the radial extend (12.5 mm) of the recombination trap and over an axial length of less than 400 mm. The minimum axial field at the center shall be 0.3 T to avoid spontaneous spin-flips by Majorana transitions. All magnet coils shall be constructed using standard NbTi superconducting wire and shall be housed in a common cryogenic system at 4.2 K. The cryogenic system must have a cold bore with an inner diameter sufficient to house the three trap structures, the dilution refrigerator cooling structure, the tuned circuits and pickup coils, and the antihydrogen detector,

These specifications can be met, as a study by commercial magnet suppliers has shown, with a system as follows:

- The axial fields for the antiproton and positron trap (2.5 T,  $\Delta B/B < 10^{-3}$  over a length of 500 mm inside a diameter of 10 mm) can be produced by two solenoids of about 600 mm length and 165 mm inner diameter, separated by a distance of  $\approx 800$  mm. This distance is sufficiently large to obtain a minimum central field of 0.3 T. Additional shim and compensation coils are used to shape the axial field profile, to minimize the distance between the solenoid coils, and to achieve the homogeneity requirements for the central (0.3 T) region.
- The radial field gradient in the central section, necessary for neutral atom confinement, can be generated by four race-track-type coils inserted between the two solenoids. Due to the large ratio of the inner diameter of the racetrack coils

(given by the bore diameter of 160 mm) to the diameter of the recombination trap (25 mm), this configuration provides a sufficiently harmonic field in the region of interest. The maximum straight side length of the coils is 280 mm. To obtain the required 0.74 T at  $r = 12.5$  mm (giving 0.8 T when adding the axial field in quadrature needed for a 350 mK well), the peak field at the winding of the quadrupole coils is 4.76 T. This is well within the standard operating range of NbTi at 4.2 K, even if the field of the solenoids at the race-track position is added in. The 0.8 T axial field position is at  $\pm 200$  mm.

- The inner diameter of the bore is 160 mm. This is a compromise between the need to place the quadrupole coils as closely as possible to the center in order to achieve the maximum field gradient, and the space needed for the traps, tuned circuits, cooling structures, and the antihydrogen annihilation detector.
- The total magnet length is 1950 mm, giving a cryostat length of approximately 2250 mm.

Figure 3 shows (a) the total magnetic field on the axis over the entire length of the magnet system, and (b) the contour map in the  $r$ - $z$  plane for the central region indicating the size of the neutral atom trap.

### 3.3 Dilution refrigerator

Antihydrogen formation and capture is favoured at low temperature: The rate of spontaneous recombination into low- $n$  levels is approximately  $\sim T^{-1/2}$ . More importantly, the kinetic energy of antihydrogen atoms at formation is determined by the 'temperature' of the antiprotons. To maximize the number of trapped antihydrogen atoms in a magnetic well of 350 mK depth, it is important to cool the antiproton plasma to temperatures in the 1 K range or below. For this purpose, a separate cooling system will be attached to the cryostat of the magnet. We intend to modify the dilution refrigerator constructed for the EMC experiment at CERN, which has become available to ATHENA. The EMC dilution refrigerator is a horizontally designed system for a maximum  $^3\text{He}$  circulation speed of 0.5 mol/s. A simplified diagram of the refrigerator is shown in figure 4. The dilution refrigerator will be connected to one end of the horizontal cryostat of the central magnet dewar discussed in the previous section.

The main modification to the dilution refrigerator will be the construction of the cold-finger, which will house the central antiproton-, positron- and recombination-trap. Since we have specified the central magnet for compatibility with the dilution refrigerator, (the bore of the central magnet has the same dimension as the EMC magnet), the internal parts of the EMC refrigerator and the coupling of the cryogenic shields will not have to be redesigned. According to the requirements of the different stages of the experiments, the cooling system can operated in different modes, reaching different final temperatures, as described below.

In the first stage of the experiment, we will study antihydrogen formation. Since the spontaneous recombination rates only vary proportional to  $T^{-1/2}$ , the production of antihydrogen at very low energies (and their subsequent annihilation on the trap



walls) can be studied at temperatures above 1 K. This can be achieved by filling the reservoir of the dilution refrigerator with liquid  $^4\text{He}$ , and then reducing the vapour pressure above the liquid by appropriate pumps. For a temperature of 1.8 K a pressure of  $\approx 10$  torr will be required. This mode of operation is simpler than the standard ( $\text{He-3/He-4}$ ) mode, and allows faster access time to the central parts of the apparatus in the initial stages of the experiment. Although at a temperature of 1.8 K a much smaller fraction of antihydrogen will be captured, the recombination dynamics can be studied, and valuable information about the energy distribution of antihydrogen can be obtained.

In the second stage, the focus of the experiment will be on maximizing the number of trapped antihydrogen atoms. This will require the use of the dilution refrigerator using a  $\text{He-3/He-4}$  mixture to reach temperatures down to 0.1 K. A cascaded system of 8 roots-blower pumps with a pumping speed of 2000-3000  $\text{m}^3/\text{h}$ , which is available to ATHENA at CERN, will allow to reach a cooling power of about 100 mW.

### 3.4 Detector

The performance of the antihydrogen detector of ATHENA has been simulated using a full GEANT Monte Carlo including all components of the central trapping system. The detector consists of five planes of silicon pad detectors (SPD's) with pixel dimensions  $1.25 \times 2.5 \text{ mm}^2$ , arranged in four towers, and of 120 CsI crystals of length 30 mm, arranged between the SPD towers. Due to the limited space available, the calorimetry and the position measurement are performed in alternating segments at similar radial position than sequentially with increasing radius. The total active length of the simulated detector is 130 mm (CsI) and 80 mm (SPD), respectively. The resulting performance is as follows:

- detection probability for a single track : 18 %
- fraction of events with reconstructible vertex : 16 % (assuming four charged particles per event)
- radial vertex resolution : 4.2 mm
- vertex resolution along the magnet axis : 8 mm
- detection probability for a single 511 keV gamma : 12 %
- detection probability for an antihydrogen annihilation : 80 %

The plots in figure 5 show an event as simulated with GEANT, and the reconstructed vertex distribution in the transverse plane, as a function of the radius and along the magnet axis. All annihilations are simulated at a radius of 12.5 mm, corresponding to the inner diameter of the trapping electrodes, and at a z-coordinate corresponding to the center of the detector.

## 3.5 Laser System

### 3.5.1 The 243 nm light source

The main goal of our experimental program, the high precision spectroscopy of anti-hydrogen, require the construction of an intense, stable, narrow band light source at 243 nm. Figure 6 shows the schematic lay-out of the system used by members of our collaboration in previous experiments on trapped hydrogen [5]. A Krypton-Ion laser pumped ring dye laser is stabilized to an external optical

resonator via a radio-frequency sideband modulation technique. The stability of this reference cavity is crucial for the experiment, and much care must be taken to achieve the highest possible finesse and the best possible mechanical isolation from the surroundings. Currently the best stability achieved is about 1 kHz at 486 nm. The light output from the ring dye laser is then doubled in a nonlinear BBO crystal, and a few tens of milliwatt output power at 243 nm is generated using a standing wave resonator. As an indication, 100 mW of circulating power and a beam waist radius of 0.4 mm will yield the necessary light intensity for reaching the initial goals of our experiment. It is our intention to build and improve upon this experience. It is anticipated to build up a new laser system along the described lines in the laser laboratory of the University of Aarhus, in close collaboration with C. Cesar from Brazil.

The aarhus group as a high level of specialized expertise of running sensitive lasers in the typically harsh environment of an accelerator laboratory. This expertise, together with the detailed knowledge of the MIT system by C. Cesar will give us the capability to generating a system adapted to the AD environment.

### 3.5.2 1S-2S Spectroscopy: a simplified detection technique

Usually, spectroscopic detection of hydrogen relies on doppler free two photon excitation of the atoms from the 1S ground state to the 2S metastable state and the subsequent detection of a Lyman $_{\alpha}$  ( $L_{\alpha}$ ) photon, which is emitted when the atom in the 2S - state is subjected to an electric quench field. Two processes lead to the loss of trapped atoms and inhibit us from cycling through these transitions indefinitely, limiting the signal-to-noise ratio for a specific number of atoms. These loss mechanism are: (a) photoionization from the 2S state and (b) decay to an untrapped hyperfine state of the 1S ground state.

For the initial phase of the antihydrogen study, we propose to adopt a simplified detection technique based on one of these loss mechanism. With this simplification we avoid the need for large detectors, apertures, optical elements, and windows for  $L_{\alpha}$  radiation during the initial phase of the experiment.

#### (a) Detection by spin-flip

After exciting the atoms to the 2S state and turning off the laser, an electric quench field ( $> 7V/cm$ ) is applied, causing a fast ( $\tau = [475(V/cm)/E_q]^2 \times 1.6ns$ ) decay of the 2S state by mixing with the 2P state. Between 20 and 40% of the decays will bring the atoms into a "high-field seeking" state, depending on the relative direction between electric and magnetic field [6]. Those atoms decaying into these non-trapped

state are accelerated towards the wall where they annihilate. A detailed analysis of the dynamic of this process shows, that all annihilations will occur in a 30  $\mu$ sec time window after excitation.

Preliminary estimates show that this detection scheme is sensitive to about 50 antihydrogens produced per minute at temperature below 350 mK. Therefore it will be sufficient for the tasks of identifying the trapped antihydrogen atoms and of performing initial spectroscopic studies on antihydrogen.

### 3.5.3 Absorption of laser light in the windows

One possible problem concerning the injection of the 243 nm laser light into the cryogenic vacuum system is the optical absorption in the windows to the vacuum environment. Under normal conditions of the hydrogen experiment at MIT [7] the absorption reached a value of up to 10% in a double passage of the laser beam.

This group performed an extensive series of studies of this problem, and the following list of conclusions summarizes their findings about the window's absorption:

- Under typical conditions at MIT, 8-10% double-pass absorption was observed.
- The absorption, on the good substrates and coatings, was due to surface contamination and not bulk effects (like color centers).
- The surface contamination would quickly develop under not-so-clean vacuum conditions and in the presence of 243 nm radiation, but with care and clean vacuum, absorptions as low as 1% were measured.

To account for this effect, we will incorporate in the ATHENA design a heat load of 10% of the 243 nm laser power at each window. For the proposed power of 100 mW and at the anticipated duty-cycle of 50 % for the 243 nm laser this is equivalent to 10 mW of CW power deposited in both windows. This power dissipation is within the cooling power of the dilution refrigerator.

## 4 Appendices

### 4.1 ATHENA - Technical Responsibilities

- **Technical Coordinator and Central Magnet Design**  
G. Rouleau, Stockholm/CERN
- **Cryogenic System, He-3 pumping**  
R. Landua, CERN
- **Antiproton System**  
M. Holzscheiter, Los Alamos-PSU
- **Positron System**  
C. Surko, UCSD; M. Charlton, UCL
- **Recombination (Nested Traps, plasma manipulation and control, amplifiers, etc.)**  
G. Rouleau, Stockholm/CERN
- **Laser Spectroscopy**  
C. Cesar, Fortaleza; J. Hangst, Aarhus
- **Detector**  
Mechanical Design: M. Doser, CERN  
Si Pad detector and read-out: E. Lodi-Rizzini, Brescia  
CsI crystals, Photodiodes: A. Rotondi, Pavia
- **Slow Control + DAQ system**  
R. Landua, CERN

## 4.2 Budget

A detailed break down of the cost for the individual components of the experiment is given below. For many of the smaller items these numbers are estimates based on the experience of members of the collaboration in similar experiments. For larger items, i.e. main laser components, magnet system, etc., we have obtained preliminary quotations from possible vendors.

<b>Antiproton Catching Trap</b>		
#	description	price estimate
1	High voltage pulser and feed throughs	40.0
2	Fabrication of trap structure	30.0
3	Slow-control system (Labview or equivalent)	50.0
6	Miscellaneous electronics (power supplies, NIM electronics, etc.)	60.0
7	Beam monitor plus read-out electronics	70.0
	<b>sub-total</b>	<b>250.0</b>
<b>Positron Accumulator</b>		
1	Three stage positron trap	140.0
2	UHV stage	50.0
3	Source chamber	50.0
4	Beam lines	15.0
5	Sealed $^{22}\text{Na}$ source	65.0
6	Electronics, computer control, interfaces vacuum gauges, etc.	30.0
	<b>sub-total</b>	<b>350.0</b>
<b>General Purpose Equipment</b>		
1	Leak detector	25.0
2	Turbo pump systems and controls	50.0
3	Desk-top Computers for simulations and data analysis	50.0
	<b>sub-total</b>	<b>125.0</b>

<b>Superconducting Magnet and Cryostat</b>		
<b>#</b>	<b>description</b>	<b>price estimate</b>
1	Magnet system (2 solenoids, 1 quadrupole) including the cryostat and all control- and monitoring instruments according to a preliminary estimate by Oxford Instr. Inc.	1,000.0
	<b>sub-total</b>	<b>1,000.0</b>
<b>Modifications to EMC refrigerator</b>		
1	Construction of new mixing chamber, rebuilding existing system, adaptation of system to new magnet, etc.	300.0
	<b>sub-total</b>	<b>300.0</b>
<b>Antihydrogen Detector</b>		
<b>(a) Charged particles</b>		
1	120 detectors	30.0
2	120 preamplifiers	30.0
3	120 preamps/drivers	20.0
4	ADC's (back plane read-out	10.0
5	C-RAMS	15.0
6	Discriminator (trigger)	10.0
7	VME-CPU for DAQ	10.0
8	VME & NIM crates	10.0
9	Mechanical mounting	15.0
10	cabeling and miscellaneous	20.0
	<b>sub-total</b>	<b>175.0</b>
<b>(b) Gamma detection</b>		
1	Crystals (raw material)	10.0
2	Crystals (cutting and polishing)	10.0
3	Crystals (mounting wrapping/glueing)	5.0
4	wave length shifters	10.0
5	Photodiodes (100)	10.0
6	Preamplifiers (100 channels)	30.0
7	Discriminator (trigger)	5.0
8	VME-CPU for DAQ	10.0
9	VME/NIM crates	10.0
10	mechanics	20.0
11	miscellaneous	20.0
	<b>sub-total</b>	<b>140.0</b>

<b>Laser System and Optics for 1S-2S Spectroscopy</b>		
1	Laser Table 3x2m	20.0
2	Coherent Kr <sup>+</sup> Laser	150.0
3	Coherent Dye laser 899	130.0
4	Reference Cavity (machining, optics and parts including Ion Pump and Temperature controller)	20.0
5	8 Modulators (Electro-Optics and Acousto-Optics) including driving electronics	12.0
6	Frequency Synthesizer with computer interface	10.0
7	Te <sub>2</sub> cell, oven and temperature controller	5.0
8	486nm optics and mounts	10.0
9	Frequency Doubler cavity and crystal	12.0
10	243nm optics and mounts	10.0
11	Servo-loop Electronics	6.0
	<b>sub-total</b>	<b>345.0</b>
<b>Hydrogen Reference System</b>		
1	Dewar	10.0
2	Magnets	20.0
3	Current Supplies	10.0
4	Machining and Electronics	10.0
5	Vacuum pumps and gas handling system	20.0
	<b>sub-total</b>	<b>70.0</b>
	<b>TOTAL</b>	<b>2,205.0</b>

## 4.3 Test Experiments

### 4.3.1 Proton-electron recombination

Some of the experimental techniques can be tested in laboratory experiments before the commissioning of the AD. In particular, we shall study the charged-conjugate reaction, namely the recombination of protons and electrons in a nested trap setup similar to the ATHENA design. Proton and electron clouds will be loaded, cooled to 4.2 K, compressed, and then merged while observing the decrease in the number of protons or electrons. For clouds of e.g.  $10^6$  protons and  $10^8$  electrons at a temperature of 4.2 K, and assuming an overlap of 20 expected. This should lead to a disappearance of about 10 within 100 sec, which is observable by standard diagnostic methods.

### 4.3.2 Cleaning of particle clouds

To eliminate any possibility of contaminants interfering with the recombination, or creating false signals, During the recombination process, the antiproton and positron clouds should be free of electron or positive ion contamination, respectively. Here the external production of positrons in the ATHENA design is a clear advantage, avoiding ion contamination due to the injection of high energy positrons into the recombination trap. Nevertheless, contaminant ions could arise and ATHENA will incorporate a cleaning procedure using resonance rf-driving and lowering of trap voltages to rid the clouds of these. In order to avoid magnetron and axial excitation of the antiprotons or positrons by the rf-drive fields, proper filtering will be required. These cleaning procedures can and will be tested with protons and electrons.

### 4.3.3 Magnetron cooling, centering and merging of the clouds

An efficient recombination scheme requires small antiproton and positron clouds, which can be achieved cooling the particles in their cyclotron, axial, and magnetron motions. In the case of the cyclotron and axial motions, the positrons will cool by synchrotron radiation ( $\approx 0.6$  s at 2.5 T); antiprotons will be cooled either by electron cooling or using a tuned circuit. Cooling time constants achieved are typically around several tens of seconds.

Much of the work on trapped ions and electrons in the past has been done on single particles or small clouds. With the parameters of total number and density of the clouds anticipated in ATHENA many of the results have to be reinterpreted. A broad experience in working with dense clouds of stored, charged particles (non-neutral plasmas) exists in the groups of C. Surko and F. Driscoll at the University of California in San Diego.

## References

- [1] R.G. Greaves and C.M. Surko, *Can. J. Phys.*, **74** (1996) 407
- [2] T.J. Murphy and C.M. Surko, *Phys. Rev. A* **46** (1992) 5696



- [3] C.M. Surko, R.G. Greaves and M. Charlton, "Stored positrons for antihydrogen production", to be published in *Hyperfine Interactions*, 1997.
- [4] See for example B.P. Cluggish, Ph.D. thesis, University of California, San Diego, 1995.
- [5] C. L. Cesar, D. Fried, T. Killian, A. Polcyn, J. Sandberg, I. A. Yu, T. J. Greytak, D. Kleppner, and J. M. Doyle; *Phys. Rev. Lett.* 77 (1996) 255
- [6] Jon Sandberg, MIT PhD thesis, unpublished (1994)
- [7] H. F. Hess, G. P. Kochanski, J. M. Doyle, N. Masuhara, D. Kleppner, and T. J. Greytak; *Phys. Rev. Lett.* 59 (1987) 672

Figure 1: Overview of the central section of the ATHENA apparatus

Figure 2: (a) Filling of positrons from a 65 mCi  $^{22}\text{Na}$  source. (b) storage of positrons at (●)  $5 \times 10^{-7}$  torr and (○)  $5 \times 10^{-10}$  torr.

Figure 3: (a) Total magnetic field along the axis of the ATHENA magnet system; (b) contours of constant total field strength in the r-z plane (from 0.3 to 1 T in increments of 0.1 T)

Figure 4: Schematic of EMC dilution refrigerator system

Figure 5: (a) Simulated event, and (b) reconstructed vertex distribution in the transverse plane

Figure 6: Schematic lay-out of 243 nm laser system

**Appendix IV**

From: LEPS5::"Rolf.Landua@MACMAIL.CERN.CH" 13-JUN-1997 01:32:25.99  
To: "Giorgio Bendiscioli" <LEPS5::"bendiscioli@vxcern.cern.ch">,  
"Antonio Bertin" <LEPS5::"bertin@bo.infn.it">,  
"Georg Bollen" <LEPS5::"Georg.Bollen@cern.ch">,  
"Marco Bruschi" <LEPS5::"Bruschi@bo.infn.it">,  
"Michael Charlton" <LEPS5::"ucapp6t@ucl.ac.uk">,  
"Maurizio Corradini" <LEPS5::"corradini@bsfis2.bs.infn.it">,  
"Daniele DePedis" <LEPS5::"depedis@vxcern.cern.ch">,  
"Michael Doser" <LEPS5::"Michael.Doser@cern.ch">,  
"John Eades" <LEPS5::"John.Eades@cern.ch">,  
"Renato Fedele"

CC:  
Subj: ATHENA Research Board Appro

Dear Collaborators,  
I have been informed that ATHENA (and ATRAP) has been approved  
by the Research Board, with the usual clause 'conditional to  
funding'. Time to open a bottle of champagne!

Rolf Landua.

**Appendix V**

Dear Friends and Collaborators,

1997 has been a very exciting year for myself and for the ATHENA collaboration.

The hard work all of you have put into preparing the proposal has paid off with the final approval of our experiment ATHENA (AD-1). We have made important design choices already and progress on all fronts is evident from meeting to meeting.

Rolf and I would like to thank you for your efforts and support.

We wish you a relaxing holiday season and a good start in a successful new year 1998 (AD-2 for AD-1 on the new tie scale of low energy antiprotons at CERN).

Michael

\*\*\*\*\*  
Below is a text version of the minutes from our last Collaboration Meeting. For those of you who can decipher it, I also attach a Word97 file. Please take note of the attached listing of all collaborators and check the entry for yourself and your close colleagues.

#### ATHENA Collaboration meeting # 9

Minutes of the Meeting of Friday, October 24, 1997  
Michael H. Holzscheiter

Present: C. Amsler, G. Bollen, M. Charlton, A. Fontana, G. Gorini, C. Hajdu, D. Horvath, M. Holzscheiter, W. Joffrain, R. Landua, E. Lodi-Rizzini, M. Macri, C. Regenfus, A. Rotondi, G. Rouleau, H. Pruys, P. Salvini, R. Schuch, C. Scoglio, G. Testera, G. Torelli,

#### 1. Approval of Minutes

Minutes from the last meeting and agenda for the present meeting were accepted without changes

#### 2. News

A new list of active collaborators has been accumulated by M. Holzscheiter. This list will be used as a basis for the entry in the Grey Book at CERN and shall also be used as a basis of collecting the common fund distribution from the individual institutions. The final list generated from this process is attached to the end of these minutes. Please double check the correctness of all entries and send update information to Michael Holzscheiter (mhh@lanl.gov).

A group from the Saratov State University and from JINR has expressed interest in joining the ATHENA collaboration. We have received a short proposal from this group (consisting of L. A. Melnikov, I. M. Umanskii, V. L. Derbov, S. I. Vinitsky, F. M. Pen'kov and I. V. Puzynin) on generating a broad band laser pulse for stimulated recombination using ultra-short pulses. While the idea sounds interesting, more studies from our sides are necessary to evaluate this method. It is proposed to invite one or two representatives from this group to a future collaboration meeting.

The AD development is on time. Installation of first experimental equipment is foreseen for May 1998, but it must be noted that the hall will be inaccessible during the commissioning time from September through December of 1998. Therefore ATHENA does not foresee to move major experimental equipment onto the AD floor before the end of 1998. Exceptions may be the

preparation of infrastructure. Immediate development work on the ATHENA apparatus will take place in the South-Hall in the zone S4. We also have two laboratories for electronic tests and small assembly work, the former Crystal Barrel laboratory and the former Obelix Development laboratory, both in Building 15 (right angle to building 23 and 22). We also have about 100 m<sup>2</sup> of storage area in the old ISR building for long term storage (i.e. the pumps for the dilution refrigerator, etc.). A constant update of the AD progress is provided on the web under the address:

[http://nicewww.cern.ch/~jyh/gp\\_ad.htm](http://nicewww.cern.ch/~jyh/gp_ad.htm)

(I had slowly improving success accessing this site from outside CERN!)

The next meeting dates were proposed as:

1. Meeting on Monday, March 23, 1997, a day before the SPSC meeting
2. Meeting somewhere mid summer, but before the general vacation time
3. Meeting in early September, when the AD commissioning starts

### 3. Report from Working Group on Traps

Michael Holzscheiter summarized the discussion of the previous day.

The following trap sectors were identified:

- (a) The positron accumulator
- (b) The positron UHV stage
- (c) The final positron storage trap
- (d) The antiproton catching trap
- (e) The recombination/nested trap

The recommendations to the collaboration were:

(a) The positron accumulator shall be assigned in its entirety to Mike Charlton at UCL. He is in close contact with Cliff Surko and has the funding and the infrastructure to deliver this equipment to ATHENA in time. Due to the funding shortfall in San Diego Cliff's participation will be on the consulting level only and the demand on Mike will be strong enough to preclude any other activity from his side for the next year. Therefore:

(b) The positron UHV storage section in itself is a relatively straight forward trap design and is ideally suited for groups wishing to gain experience in trap operation. It therefore shall be build by students from both Zuerich and Stockholm under the direct supervision of Gary Rouleau at CERN. The goal of this trap is to be able to hold up to 10<sup>10</sup> positrons for  $t > 10$  hours and accept successive bunches from the accumulator. For more details see the copies of the transparencies from the meeting.

(c) The final storage trap inside the main ATHENA system can be a copy of the first trap Gary is currently constructing for the PS200 magnet. The main purpose of this trap is to provide a long term storage capability and give the necessary control to compress and center the positron plasma in preparation for the injection into the recombination trap.

(d) The design of the ATHENA catching trap will be done by M. Holzscheiter, based on his experience with the PS200 trap. It has been decided to adapt the PS200 magnet for this task by either modifying the EMC refrigerator to be used with the PS200 magnet or by purchasing a new 1 K insert for the PS200 magnet. Discussions with Oxford Instruments on this topic are in progress and a final recommendation will be given no later than the March meeting.

(e) The recombination trap is the most demanding section in terms of physics and the different groups need to work closely together on this topic. To avoid duplication of effort it was in broad terms decided that G. Rouleau will concentrate on work with electrons, both in terms of radial compression as well as in terms of axial transfer and mixing. He presented a brief outline of the current multi-ring trap design. He plans to build

this trap and test it in the vertical magnet from Los Alamos. This magnet is currently at Oxford Instr. For repair and is retrofitted with a 1.8 K Lambda point cooler and is expected to arrive at CERN early 1998. The work on proton/antiproton cooling and compression has been taken on by the group in Genoa. They will modify an existing, horizontal bore, superconducting magnet to accept a cryo-insert for operation at 4 K to perform first tests on compressing a proton plasma. This magnet could possibly be used at a later stage for the UHV positron storage, or could remain at Genoa for future tests. A decision on this question should be taken no later than next summer.

Vittorio Lagomarsino summarized their plans on cooling and compression tests in Genoa. The detailed numbers on trap parameters are given on the transparencies. The essential goal of the work is to (1) continuously monitor the number of antiprotons (at a 10% precision), (2) to continuously monitor the radius of the plasma, and (3) to control the radial extent (compress) of the cloud. It was noted that the working point is well outside the plasma regime and standard techniques from earlier trap work can be used.

The fundamental idea is to use the cyclotron motion to monitor the particle number by coherently exciting the motion with a dipole field across the ring electrode and then monitoring the image charge. Using a quadrupole field configuration instead, the cyclotron radius will increase proportional the initial magnetron radius, allowing monitoring of the bunch dimensions. Finally, the second procedure can be used to compress the bunch by first pumping the magnetron radius into the cyclotron energy and then cool the cyclotron energy stochastically before reversing the role of cyclotron and magnetron radius again.

The collaboration welcomes the initiative taken by the group from Genoa and is looking forward to a first update at the next meeting in March.

4. G. Torelli gave a report on his work studying the influence on the Antihydrogen Formation rate due to the limiting parameters in the trap. Copies of his transparencies and a copy of a preprint describing these calculations were distributed. An updated and corrected version of this paper will be distributed by Gabriele as soon as it is finished. The most important message is that even for favorable cross sections the actual dynamics of the trapped particles (i.e. rotational energy and well depth of the neutral trap) may severely lower the useful rate. These considerations have to be carefully studied before the final design of the central apparatus can be done.

5. Reinhold Schuch introduced his group in Stockholm and gave a summary of the work at his institute. He described in detail the work on merged electron-ion beams for studying radiative and stimulated recombination. He clearly demonstrated that the relevant phase space (in the co-moving reference frame) is very similar to what is expected in traps and that many of his studies are directly applicable to our problems. He also described some of the experiment on laser induced recombination of  $D^+ + e^- \rightarrow D(2l)$  showing an enhancement factor of about 30. Many of the detailed mechanism are still unclear and he wants the collaboration from accepting naïve calculations at face value. The physics here is much more complicated and he has a strong interest in pursuing this area further, which clearly will benefit the ATHENA collaboration.

6. Rolf Landua reported from the Detector Working Group meeting. The essential result of the discussions were a completely new detector design which was agreed upon. Instead of consisting of individual quadrants the design is now fully concentric. The necessary room for this design was made available through the use of thin silicon micro-strips instead of the 4 layers of Si-Pads in the earlier design. The performance of the new detector is equal or better to the previous design. The only drawback is



the loss of modularity (i.e. to insert a Lyman-alpha detector in place of one of the quadrants - but this may not be of relevance for many years to come.

The detection of the 511 keV gammas is now planned with long CsI crystals readout from either end instead from the back. This simplifies the system and allows for a longer area of coverage. Also, the new design allows a full 2pi coverage.

The responsibilities for the detector design were assigned as follows:

Pavia: Crystals (with help from Zuerich)

Zuerich: Silicon Analog (include. Front End Read-out)

Brescia: Silicon Digital Processing

7. The next meeting will be held approximately on March 23, 1997. At this time we expect detailed progress reports from the different activities on trap design, magnet modification, and detector development. The final agenda will be send out in preparation for this meeting at the end of February.

NEW ATHENA COLLABORATION MEMBER LIST: PLEASE CHECK ALL ENTRIES AND SEND CORRECTIONS TO MICHAEL H. HOLZSCHEITER

Georg Bollen CERN/PPE CH1211 Geneva Switzerland  
+41-22-767-5825  
+41-22-767-8990 georg.bollen@cern.ch

Michael Doser CERN/PPE Bldg 23-1-003 CH 1211 Geneva Switzerland  
+41-22-767-6552 +41-22-767-8955 michael.doser@cern.ch

John Eades CERN/PPE Bldg. 3-1-027 CH1211 Geneva Switzerland  
+41-22-767-4273  
john.eades@cern.ch

Rolf Landua CERN/PPE Bldg. 23-1-007 CH 1211 Geneva Italy  
+41-22-767-2051  
+41-22-767-8955 rolf.landua@cern.ch

Gary Rouleau CERN/PPE Bldg 23-1-019 CH 1211 Geneva Switzerland  
+41-22-767-2098 +41-22-767-8955 gary.rouleau@cern.ch

Gianluca Gemme INFN Genova Via Dodecaneso 33 Genova  
Italy

Vittorio Lagomarsino INFN Genova Via Dodecaneso 33  
Genova Italy  
+39-10-3536433 +39-10-313358 lagomarsino@infnge.ge.infn.it

Mario Macri INFN Genova Via Dodecaneso 33 Genova Italy  
+39-10-353-6328  
+39-10-310075 macri@infnge.ge.infn.it

Giulio Manuzio INFN Genova Via Dodecaneso 33 Genova Italy  
+39-10-353-6231  
+39-10-313358 manuzio@genova.infn.it

Gemma Testera INFN Genova Via Dodecaneso 33 Genova Italy  
+39-10-3536433  
+39-10-313358 testera@infnge.ge.infn.it

Renato Fedele INFN Naples Naples Italy

Andrea Cantone INFN/Univ. Brescia Brescia Italy

Evandro Lodi-Rizzini INFN/Univ. Brescia Brescia Italy  
+39-303-715710  
Lodirizz@vxcem.cern.ch

Lucca Venturelli INFN/Univ. Brescia Brescia Italy  
+39-303-715701  
+39-302-091271 venturelli@axpbs1.bs.infn.it

Andrea Fontana INFN/Univ. Pavia Pavia Italy  
+39-382-507424  
fontana@pv.infn.it

Alberto Rotondi INFN/Univ. Pavia Pavia Italy  
+39-382-507423  
rotondi@pv.infn.it

Paola Salvini INFN/Univ. Pavia Pavia Italy  
+39-382-507630  
salvini@pv.infn.it

Claudia Scoglio INFN/Univ. Pavia Pavia Italy  
+39-382-507424  
claudia.scoglio@pv.infn.it

Claudio L. Cesar Instituto de Fisica - UFRJ CT A318 Ilha do  
Fundao Rio de  
Janeiro Brazil, RJ 21945-0970 +55-86-986-3408 + 55-21-280-7693  
lenz@if.ufrj.br

Terrence Goldman Los Alamos Nat. Lab. T-5, MS B283 Los Alamos,  
NM 87454 USA  
+1-505-667-4835 t.goldman@lanl.gov

Michael Holzscheiter Los Alamos Nat. Lab. P-23, MS H803 Los Alamos,  
NM  
87545 USA +1-505-665-0491 +1-505-665-4121 holzscheiter@lanl.gov

Richard Hughes Los Alamos Nat. Lab. P-23, MS H803 Los Alamos, NM 87545  
USA  
+1-505-667-3876 +1-505-665-4121 hughes@lanl.gov

Nicholas King Los Alamos Nat. Lab. P-23, MS H803 Los Alamos,  
NM 87545 USA  
+1-505-667-6306 +1-505-665-4121 king@lanl.gov

George Morgan Los Alamos Nat. Lab. P-23, MS H803 Los Alamos, NM 87545  
USA  
+1-505- +1-505-665-4121 glmorgan@lanl.gov

Michael M. Nieto Los Alamos Nat. Lab. T-8, MS B285 Los Alamos,  
NM 87545 USA  
+1-505-667-6127 +1-505-665-3003 mmn@pion.lanl.gov

Ray Lewis Pennsylvania State Univ. 303 Osmond Laboratory  
University Park,  
PA 16802 USA +1-814-863-3342 +1-814-863-3297  
rxl@leps.phys.psu.edu

Gerald A. Smith Pennsylvania State Univ. 303 Osmond  
Laboratory University  
Park, PA 16802 USA +1-814-863-3076 +1-814-863-3297  
smith@leps3.phys.psu.edu

Csaba Hajdu RIPNP Budapest H-1525 Hungary Switzerland  
+41-22-767-8774  
csaba.hajdu@cern.ch

Deszo Horvath RIPNP Budapest H-1525 Budapest Hungary +36-1-395  
9220  
+36-1-395-9151 horvath@rmki.hfki.hu

Dino Zanello Rome University "La Sapienza" Rome Italy  
+39-4991-4832

Toshimitsu Yamazaki Tokyo Univ./Japan Soc. for Prom. Science  
Tokyo Japan  
+81-3-32631721 +81-3-3237-8238 yamazaki@tkyvax.phys.s.u-tokyo.ac.jp

Ryugo Hayano Tokyo University Dept. of Physics Tokyo  
Japan +81-3-568-97343  
+81-3-381-10960 hayano@phys.s.u-tokyo.ac.jp

Yasunori Yamazaki Tokyo University Institute of Physics  
Tokyo Japan  
+81-3-5454-6521 yasunori@phys.c.u-tokyo.ac.jp

Clifford Surko UCSD Dept. of Physics La Jolla, CA USA  
+1-619-534-6880  
+1-619-534-0173 csurko@ucsd.edu

Giampaolo Gorini Universita di Pisa Piazza Toricelli 2  
56100 Pisa Italy  
+39-50-911205 +39-50-48277 gorini@mailbox.difi.unipi.it

Gabriele Torelli Universita di Pisa Piazza Torricelli 2  
56100 Pisa Italy  
torelli@pi.infn.it

Claude Amsler Universität Zürich CERN, Bldg 22-1-020 CH 1211  
Geneva  
Switzerland +41-22-767-2914 +41-22-767-8955 amsler@cern.ch

E. Hermes Universität Zürich Zürich Switzerland

Farid Ould-Saada Universität Zürich Zürich  
Switzerland

Henk Pruis Universität Zürich Zuerich Switzerland  
+41-56-3103646  
pruis@physik.unizh.ch

Christian Regenfus Universität Zürich CH 1211  
Geneva Switzerland  
+41-22-767-2047 +41-22-767-8955 regenfus@cern.ch

Mike Charlton University College London Dept. of Physics &  
Astr. London UK  
+44-171-419-3472 +44-171-380-7145 m.charlton@ucl.ac.uk

Matthew J. T. Collier University College London London

Jeff Hangst University of Aarhus Inst. for Physics & Astronomy  
DK-8000  
Aarhus C Denmark +45-89-423-751 +45-86-120740 hangst@dfi.aau.dk

Jon Merrison University of Aarhus Institut for Physics & Astr.  
DK 8000  
Aarhus C Denmark +45-89-423-765 +45-86-120740  
merrison@dfi.aau.dk

Erik Uggerhoj University of Aarhus Institute of Physics & Astr.  
DK 8000  
Aarhus Denmark +45-89-423705 +45-86-120740 ugh@dfi.aau.dk

Conny B. A. Carlberg University of Stockholm Stockholm  
Sweden

Nils Ekloew University of Stockholm Stockholm Sweden

Reinhold Schuch University of Stockholm Stockholm  
Sweden +46-8-161046  
+46-8-157986 schuch@msi.se

**Appendix VI**

# PHYSICS OF ANTIMATTER

Gerald A. Smith  
Penn State University

Physics for the Third Millennium  
Lecture Series

Marshall Space Flight Center  
February 9-12, 1998

<http://antimatter.phys.psu.edu>

[Smith@leps3.phys.psu.edu](mailto:Smith@leps3.phys.psu.edu)

## **AGENDA**

- 1. Introduction: early history and fundamentals**
- 2. Production of antiprotons**
- 3. Antiproton trapping**
- 4. Antihydrogen physics**
- 5. Antimatter gravity**
- 6. Propulsion applications**
- 7. Medical applications**

# **INTRODUCTION TO ANTIMATTER**

## **History and Fundamentals**



OCTOBER 27, 1898]

NATURE

### Potential Matter.

ALLOW me to refer once more to the subject of my letter of August 18, in order to draw attention to two previous investigations with which, at the time of writing, I was unacquainted. Prof. Karl Pearson has, under the title of "Ether Squirts" (*American Journal of Mathematics*, vol. xiii. No. 4), worked out mathematically the theory of matter considered as sources and sinks of fluid, and draws attention to the fact that this theory implies the existence of "negative matter," which may exist outside the solar system. More recently A. Föppl, in a communication to the Munich Academy, dated February 1, 1897 (*Sitzungsber. der k. b. Akad. d. Wiss.*, 1897, i. p. 93), has published a short paper under the title, "Ueber eine mögliche Erweiterung des Newton'schen Gravitations-Gesetzes." Starting from the idea that there is a difference in kind between the electrical and magnetic fields of force on the one hand, and the gravitational field on the other, because the flux of force through a sphere converges towards zero with increasing radius of the sphere for the electric and magnetic fields, but not, as usually defined, for the gravitational field, Föppl gives the necessary extension to Newtonian law of gravitation in order to remove the distinction. This, of course, implies "negative matter." There is a marked difference between the expression for the energy of the gravitational field on Föppl's hypothesis with that which is derived from the ether squirt theory; but it is not necessary to enter into this question.

There are some points in my former communication, to which previous writers on the subject have, however, not, as far as I know, drawn attention. Among them is the insufficiency of the ordinary hypothesis to account for the rotational momentum of our solar system which cannot be self-generated, the possibility of having evidence of anti-matter in comet tails and coronal streamers, and the idea of potential matter.

ARTHUR SCHUSTER

# DISCOVERY OF ANTIMATTER (1933)

The Positive Electron

CARL D. ANDERSON, *California Institute of Technology, Pasadena, California*

(Received February 28, 1933)

## NOBEL PRIZE (1936)

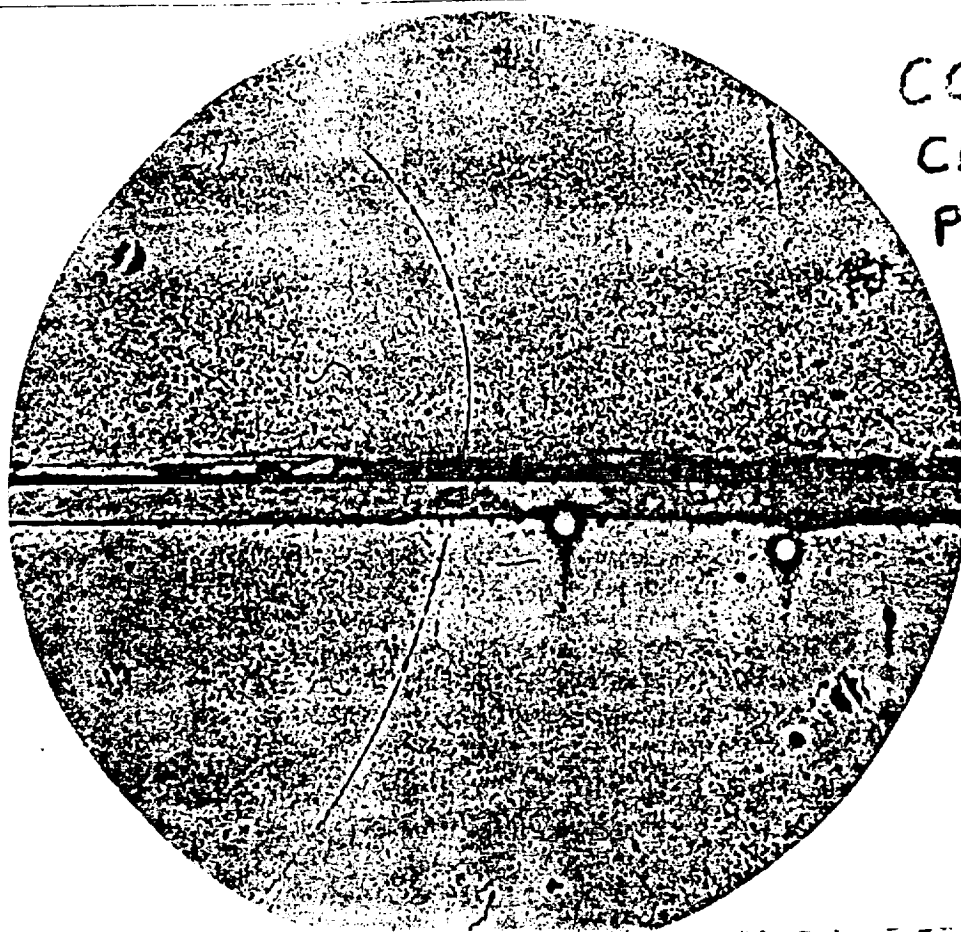

COSMIC RAYS:  
CLOUD CHAMBER  
PHOTOGRAPH

FIG. 1. A 63 million volt positron ( $H_p = 2.1 \times 10^4$  gauss-cm) passing through a 6 mm-lead plate and emerging as a 23 million volt positron ( $H_p = 7.5 \times 10^4$  gauss-cm). The length of this latter path is at least ten times greater than the possible length of a proton path of this curvature.

CONFIRMED PREDICTION OF P. DIRAC (1929)  
QUANTUM FIELD THEORY

THAT PARTICLES ELEVATED FROM THE SEA OF "NEGATIVE ENERGY STATES LEAVE BEHIND HOLES" WHICH CORRESPOND TO PHYSICAL ANTIPARTICLES

# Theory of the Positron

by P. A. M. Dirac.

## NOBEL PRIZE (1933)

The recent discovery of the positively charged electron or positron has revived interest in a theory about the range states of negative kinetic energy of an electron, as the experimental results that have been obtained so far are in agreement with the predictions of the theory.

The question of negative kinetic energies arises as soon as we consider the motion of a particle according to the principle of restricted relativity. In non-relativistic theory the energy  $W$  of a particle is given in terms of its velocity  $v$  or its momentum  $p$  by

$$W = \frac{1}{2}mv^2 = \frac{1}{2m}p^2,$$

which makes  $W$  always positive, but in relativistic theory this formula must be replaced by

$$W^2 = m^2c^4 + c^2p^2$$

or

$$W = c\sqrt{m^2c^2 + p^2},$$

which allows  $W$  to be either positive or negative.

One usually makes the extra assumption that  $W$  must always be positive. This assumption is permissible in the classical theory, where variables always vary continuously, since  $W$  can then never change from one of its positive values, which must be  $\geq mc^2$ , to one of its negative values, which must be  $\leq -mc^2$ . In the quantum theory, however, discontinuous changes of a variable may take place, so that  $W$  may change from a positive to a negative value. It has not been found to be possible to set up a

# Seetee

Jack Williamson

1949-51

## ANTIMATTER UNLEASHED!

It happened. A sudden glare of blinding light, silent, yet startling as a scream. It burned all the color from the glass fronts of the warehouses, and splashed the leaning ships with hot blue fire, and cast shadows like frozen ink. He didn't look toward it, but he knew what it was.

Seetee—reacting with something terrene. Attracted atoms crashing into unlike atoms and ceasing to be atoms. Mass shattered into untamed and pitiless energy, with a thousand times the fury of fissioning plutonium. He ducked his head and ran.

He didn't look back.

THE PHYSICS OF

STAR TREK

LAWRENCE M. KRAUSS

WITH A FOREWORD BY  
STEPHEN HAWKING



BasicBooks

*A Division of HarperCollinsPublishers*



■ **Left: *Emilio Segrè*. Right: *Owen Chamberlain*. Segrè and Chamberlain received the Nobel Prize in physics in 1959 for their research leading to the discovery of the antiproton.**

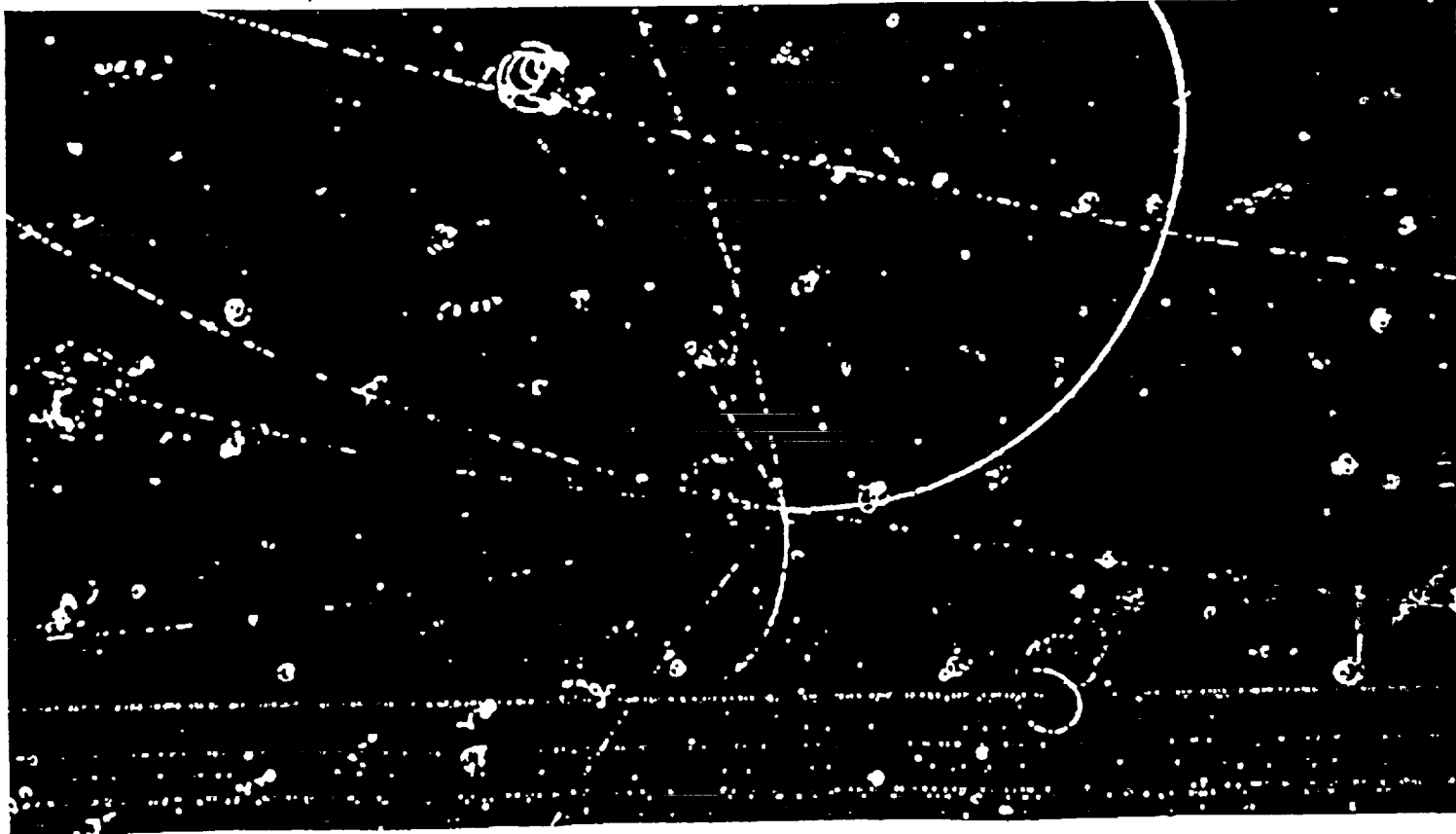

# PROTON-ANTIPROTON ANNIHILATION

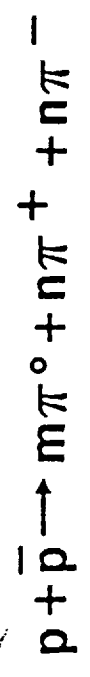
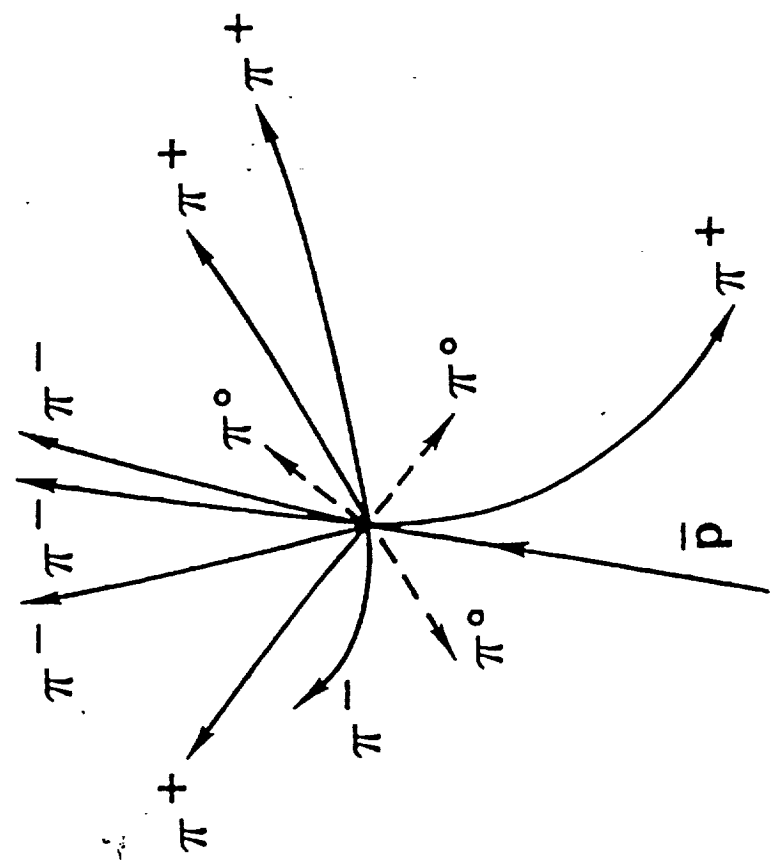

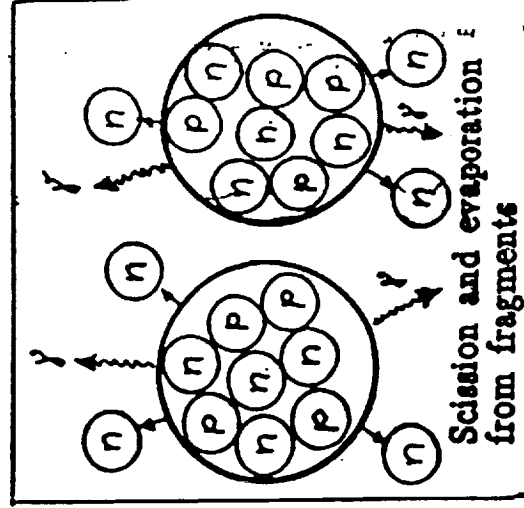
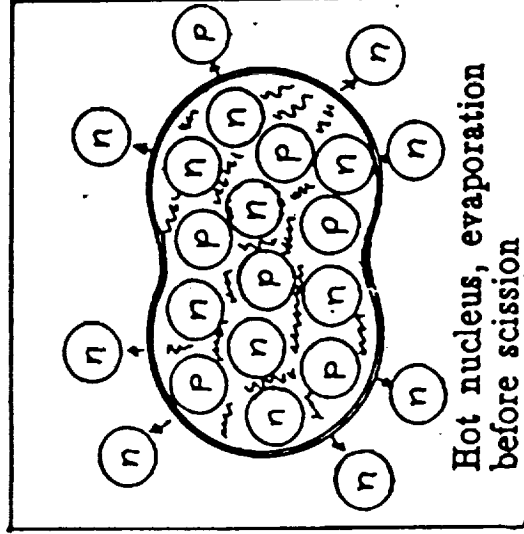
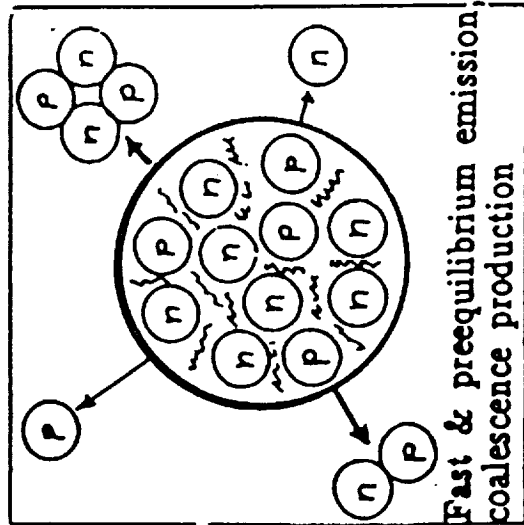
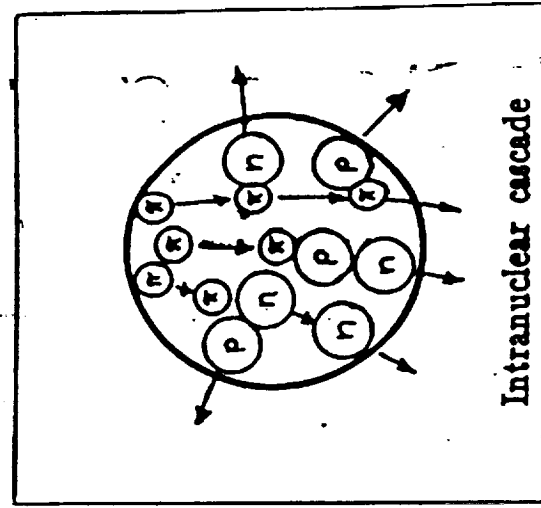
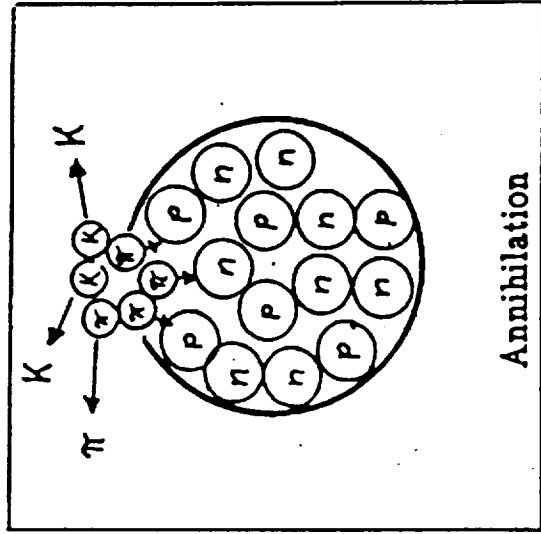
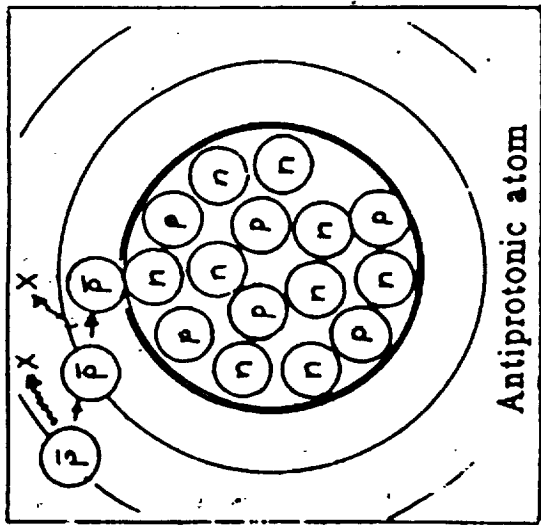

Figure 1. Reactions taking place when an antiproton is stopped in matter and annihilates at a nucleus leading to fission.



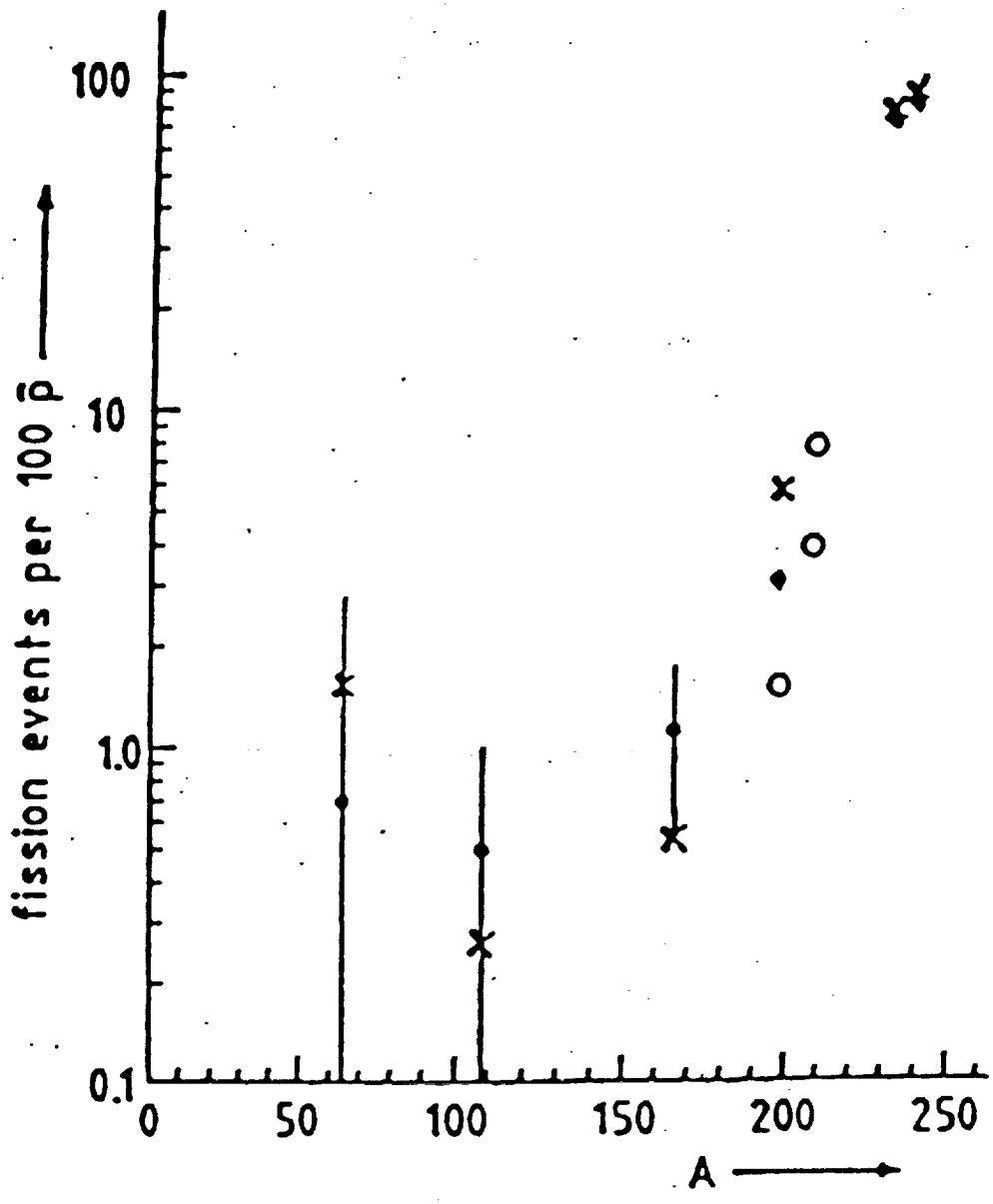
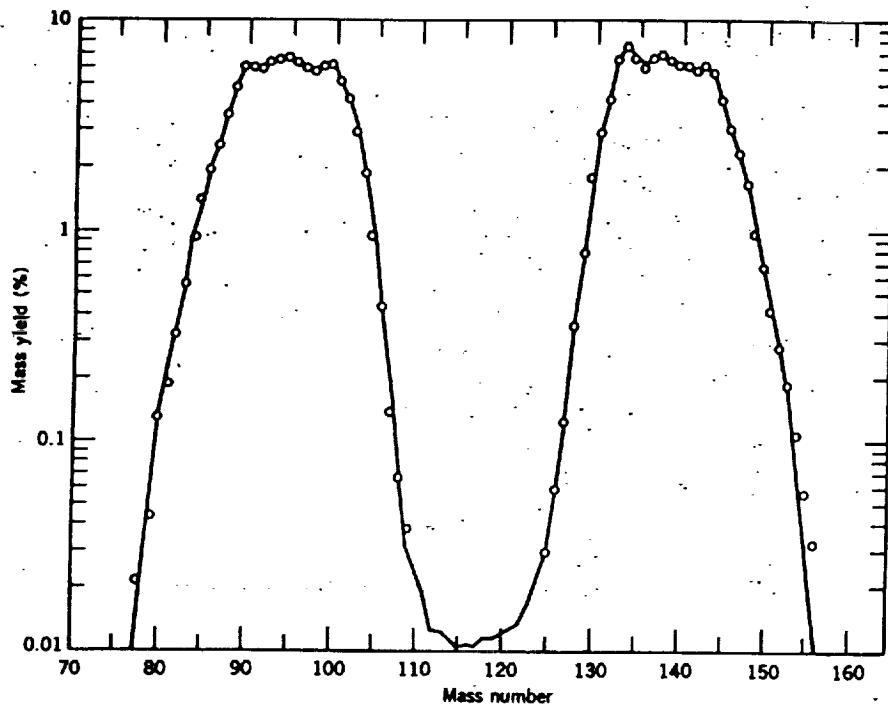
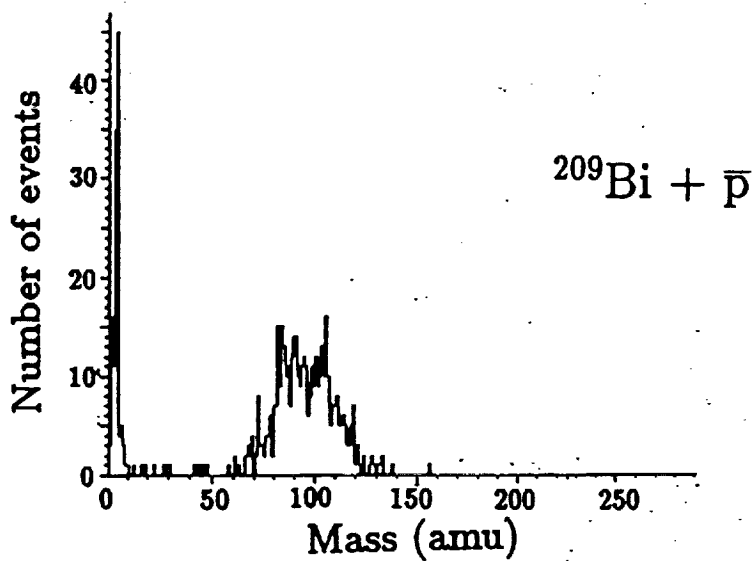
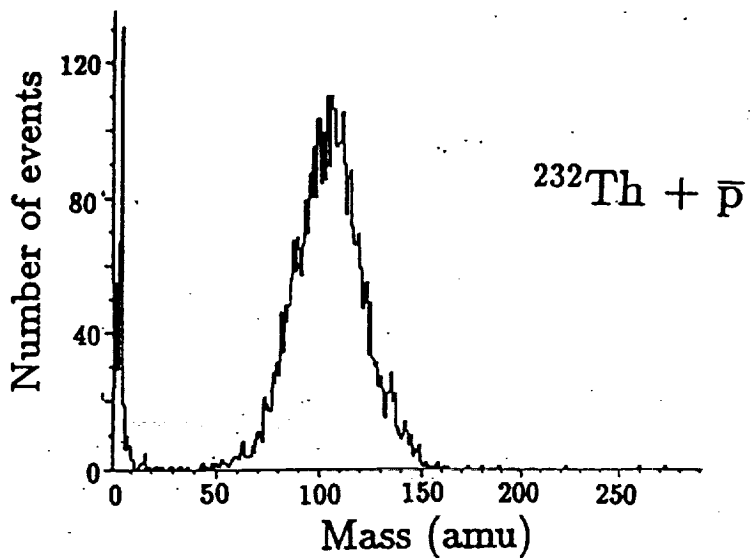
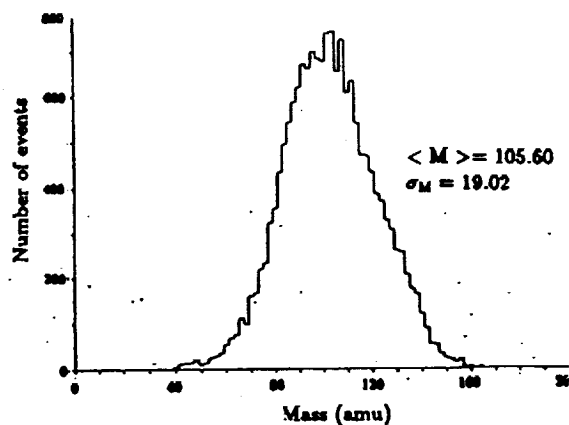

Fig. 3. Absolute fission probabilities for Cu, Ag, Ho, Au,  $^{208}\text{Pb}$ , Bi, Th and U targets [6].



**Figure 13.6** Mass distribution of fission fragments from thermal fission of  $^{235}\text{U}$ . Note the symmetry of the heavy and light distributions, even in the small variations near the maxima. From G. J. Dilorio, *Direct Physical Measurement of Mass Yields in Thermal Fission of Uranium 235* (New York: Garland, 1979).

Mass Distribution  $^{238}\text{U}(p,f)$



# Fission fragment distribution following antiproton absorption at rest on $^{238}\text{U}^*$

H. Machner<sup>1</sup>, Sa Jun<sup>1, \*\*</sup>, G. Riepe<sup>1</sup>, D. Protic<sup>1</sup>, H. Daniel<sup>2</sup>, T. von Egidy<sup>2</sup>, F.J. Hartmann<sup>2</sup>, W. Kanert<sup>2</sup>, W. Markiel<sup>2</sup>, H.S. Plendl<sup>2, \*\*\*</sup>, K. Ziock<sup>3</sup>, R. Marshall<sup>3</sup>, and J.J. Reidy<sup>4</sup>

<sup>1</sup>Institut für Kernphysik, Forschungszentrum Jülich, Postfach 1913, W-5170 Jülich, Federal Republic of Germany

<sup>2</sup>Physik-Department, Technische Universität München, James-Franck-Strasse, W-8046 Garching, Federal Republic of Germany

<sup>3</sup>University of Virginia, Charlottesville, VA 22901, USA

<sup>4</sup>University of Mississippi, University, MI 38677, USA

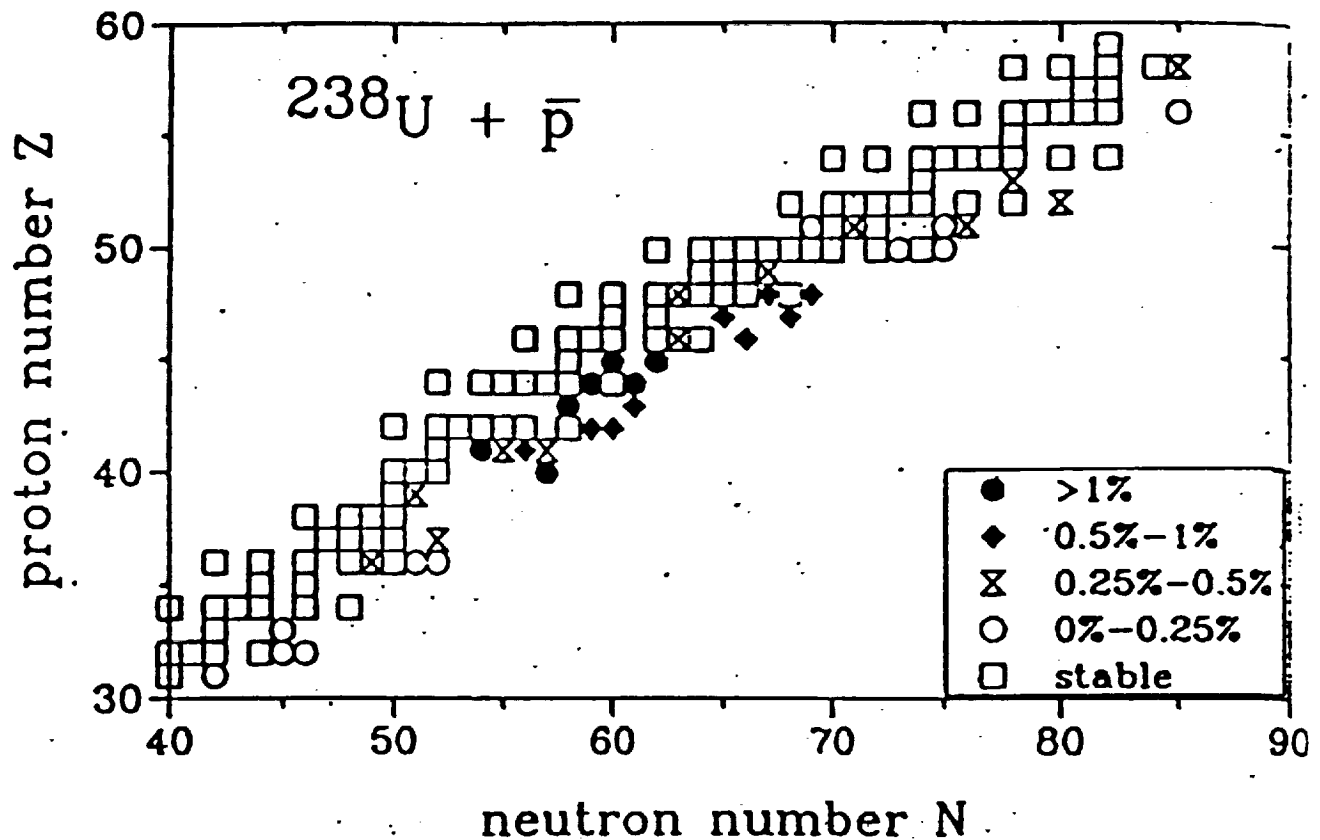

Fig. 2. Section of the chart of nuclides. The measured nuclides are shown with different symbols according to their intensity per 100 incident  $\bar{p}$ 's. Also shown are the stable isotopes

# NUCLEAR REACTIONS IN HEAVY ELEMENTS

## Fission Fragment Yields

A Data Handbook

V. M. Gorbachev

Y. S. Zamyatnin

A. A. Lbov



PERGAMON PRESS

OXFORD · NEW YORK · TORONTO · SYDNEY · PARIS · FRANKFURT

●  $n_{th} + U^{235}$   
○  $\bar{p} + U^{238}$

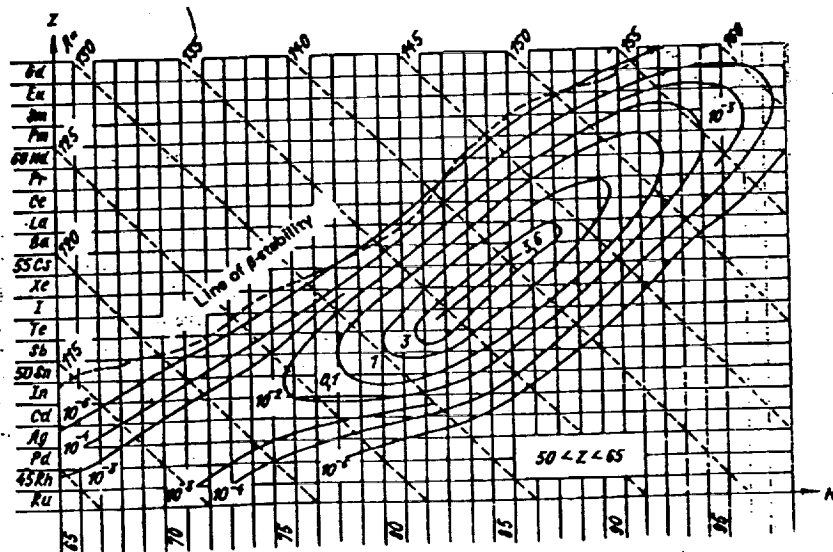
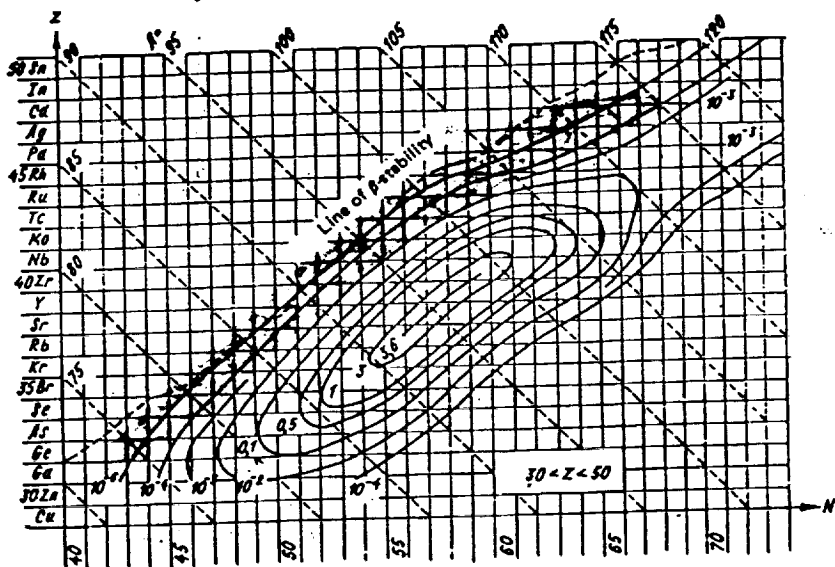

Fig. 6.23. Absolute independent fragment yields (%) for fission of  $^{235}\text{U}$  by thermal neutrons [439].

# CERN COURIER

INTERNATIONAL JOURNAL OF HIGH ENERGY PHYSICS

VOLUME 36

2

MARCH 1996

## One hundred years to the day

The recent discovery at CERN of antihydrogen caught the attention of the media more than any other physics development in recent years. The CERN press release which started the bandwagon rolling went out on 4 January. Broadcast over the Internet via the World Wide Web, it made prime time TV and headlines all over the world the following day. Curiously, one hundred years previously, Wilhelm Röntgen in Würzburg mailed the news of his dramatic new X-ray discovery on 1 January. With no Internet, the first press report was carried in the Wiener Presse of 5 January 1896. By 16 January, the news had crossed the Atlantic to reach the New York Times. The news of a mysterious 'all revealing radiation' went on to produce about a thousand newspaper reports that year.

# Physicists Succeed in Creating Atoms Out of Antimatter

By MALCOLM W. BROWNE

Physicists at the European Laboratory for Particle Physics announced yesterday that they had created, for forty-billionths of a second, the first complete atoms of antimatter ever made by human beings or seen in nature.

In an antiatom, the antimatter equivalent of an ordinary atom, the electrical charges of all the component particles are reversed; while an ordinary atom has a positively charged nucleus with one or more negatively charged electrons orbiting it, the antimatter atom has a negatively charged nucleus with positively charged orbiting electrons. An ordinary atomic nucleus contains positively charged protons, while its antimatter counterpart contains negatively charged antiprotons.

Unless an antimatter atom is kept from coming into contact with an ordinary atom, the two atoms annihilate each other in a violent flash of energy — a fact that may explain the apparent absence of antimatter in the natural universe. Antiprotons are routinely made in physics laboratories, as are antielectrons, which are also called positrons. But no one had heretofore succeeded in nudging a positron into orbit around an antiproton, making an atom of antimatter. The announcement yesterday by the European laboratory near Geneva, known by its former acronym, CERN, establishes that this bizarre kind of atom can actually exist.

Physicists hope one day to make comparative measurements of the properties of atoms and antiatoms in terms of their gravitational attraction, their interactions with light, and other features. Subtle differences between atoms and their antimatter counterparts may shed light on the origin and evolution of the universe and help solve the puzzle as to why we are made of matter instead of antimatter.

Although most physicists discount the idea that antihydrogen might one day be developed as a very high potency fuel for interstellar rockets or superbombs, some scientists have not abandoned the dream of exploiting antimatter as a propellant. When combined with ordinary matter it annihilates, converting mass to energy far more efficiently than does a nuclear bomb.

Dr. Walter Oelert of the Jülich Institute for Nuclear Physics Research in Germany and his German and Italian colleagues reported that they created the 11 atoms of antihydrogen during a three-week experiment at CERN last September, but withheld the news until they and independent experts had thoroughly

## A CLOSER LOOK

### Not Since the Beginning of the Universe . . .

Physicists announced yesterday that they had created the first atoms of antimatter. Here is how they did it:

**Antiprotons pass through . . .** A beam of antiprotons (negatively charged protons) is shot into xenon gas.

**... Xenon gas, creating antielectrons which can combine with . . .** Some pass through unaffected while others interact with the xenon to form antielectrons (positively charged electrons). They normally exit the gas in separate paths.

**... Antiprotons, to create antimatter.** In very rare instances, the antielectrons are attracted to, and begin to orbit, the antiprotons, creating antihydrogen.

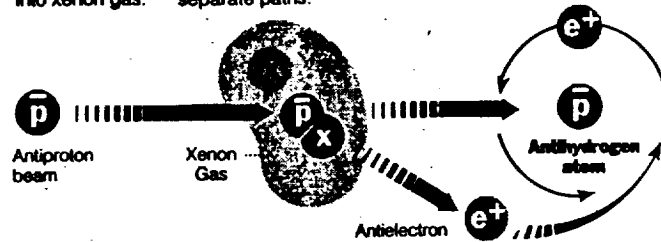

The New York Times

checked their results, which will be published in a forthcoming issue of the journal *Physical Review B*.

"We're absolutely sure now," he said in an interview, "and the experiment shows without doubt that antihydrogen can exist. No one really doubted it, but it's nice to have the experimental proof."

The antihydrogen atoms created in the experiment were moving at nearly the speed of light and survived only some forty-billionths of a second before colliding with atoms of ordinary matter and annihilating themselves. But from the pattern and types of debris created by these collisions, the scientists were able to establish the identity of the projectiles as antihydrogen atoms.

Dr. John Eades, the British coordinator of experiments at CERN, said that the real challenge had been in producing enough of the right kind of collisions between ordinary particles to create a few antihydrogen atoms. To do this, antiprotons from one of CERN's accelerators were boosted to very high energy and hurled into a target of xenon atoms, each atom containing a nucleus with 54 protons and about 77 neutrons.

Some of the antiprotons survived and passed through, while others collided with xenon nuclei, converting part of their collision energy into the creation of antielectrons (also called positrons). In a few very rare cases, the speeds and directions of the newly born antielectrons and the surviving antiprotons coincided enough

## A bizarre atom may shed light on the nature of universe.

that the antielectrons were captured into orbits around the antiprotons, thus forming antihydrogen atoms. These atoms, like ordinary hydrogen atoms, are electrically neutral, since the charges of their components cancel each other.

But the neutrality of antihydrogen, like that of ordinary hydrogen, renders it impossible to contain or manipulate using magnetic fields. Moreover, an antiatom cannot be contained in an ordinary vessel, since the slightest contact with the container's wall causes it to annihilate. Consequently, other groups are developing enormously sophisticated methods, including interacting lasers, to manipulate and secure anti-particles inside vacuum chambers.

Dr. Oelert acknowledges that the antihydrogen atoms his group made cannot be used as the basis of far-reaching experiments in the fundamental interactions of physics, including such cosmological questions as to why the universe seems to consist entirely of matter rather than antimatter.

"We just wanted to have fun and see if you could make antihydrogen," he said. "It maybe is not such a great scientific achievement in itself, be-

cause our antihydrogen atoms are moving around much too fast to study in detail before they annihilate."

Meanwhile, physicists at Harvard University, Pennsylvania State University, Los Alamos National Laboratory and other groups are attempting to create, capture and control antihydrogen in a more useful form. Their efforts focus on "cooling" antiprotons and antielectrons using lasers and other tools, and assembling atoms not by violent collisions but by manipulation. Such atoms, when they are eventually made, will be held almost motionless in their chambers, isolated from contact with ordinary matter while their gravitational, spectral, charge-conjugation, parity and other characteristics are measured.

"Everyone makes shrewd guesses about the probable behavior of antihydrogen and other antiatoms," Dr. Eades said, "and we don't really expect a big surprise — that an atom of antimatter would fall up instead of down, for instance. But there may be subtle differences of great importance. For instance, an atom and an antiatom might fall at slightly different speeds toward a gravitating object like the sun. Our orbit around the sun is elliptical, so the sun's gravitational pull on the earth varies slightly over a year, and by observing its effect on an antihydrogen atom, we might learn interesting things."

In principle, scientists believe that atoms larger than antihydrogen — the simplest possible atomic form of antimatter — might be created. But each increase in the size and complexity of an atom complicates the assembly problem. Antihelium, the most complicated atom after hydrogen, would have a nucleus of two antiprotons and two antineutrons, with two orbiting antielectrons.

"We're especially interested in hydrogen and antihydrogen," Dr. Eades said, "not only because of their structural simplicity, but because 90 percent of the mass of the universe is hydrogen. Even slight differences in the properties of hydrogen and antihydrogen could help explain why the universe, as we know it, consists entirely of matter rather than antimatter."

Dr. Gerald Gabrielse of Harvard University, whose research group is working to slow down particles of antimatter contained in special traps, commented that the CERN synthesis of antihydrogen "is an important experiment demonstrating that it can be done. The payoff will be down the road, when one is eventually able to study the properties of these atoms."

# DER SPIEGEL

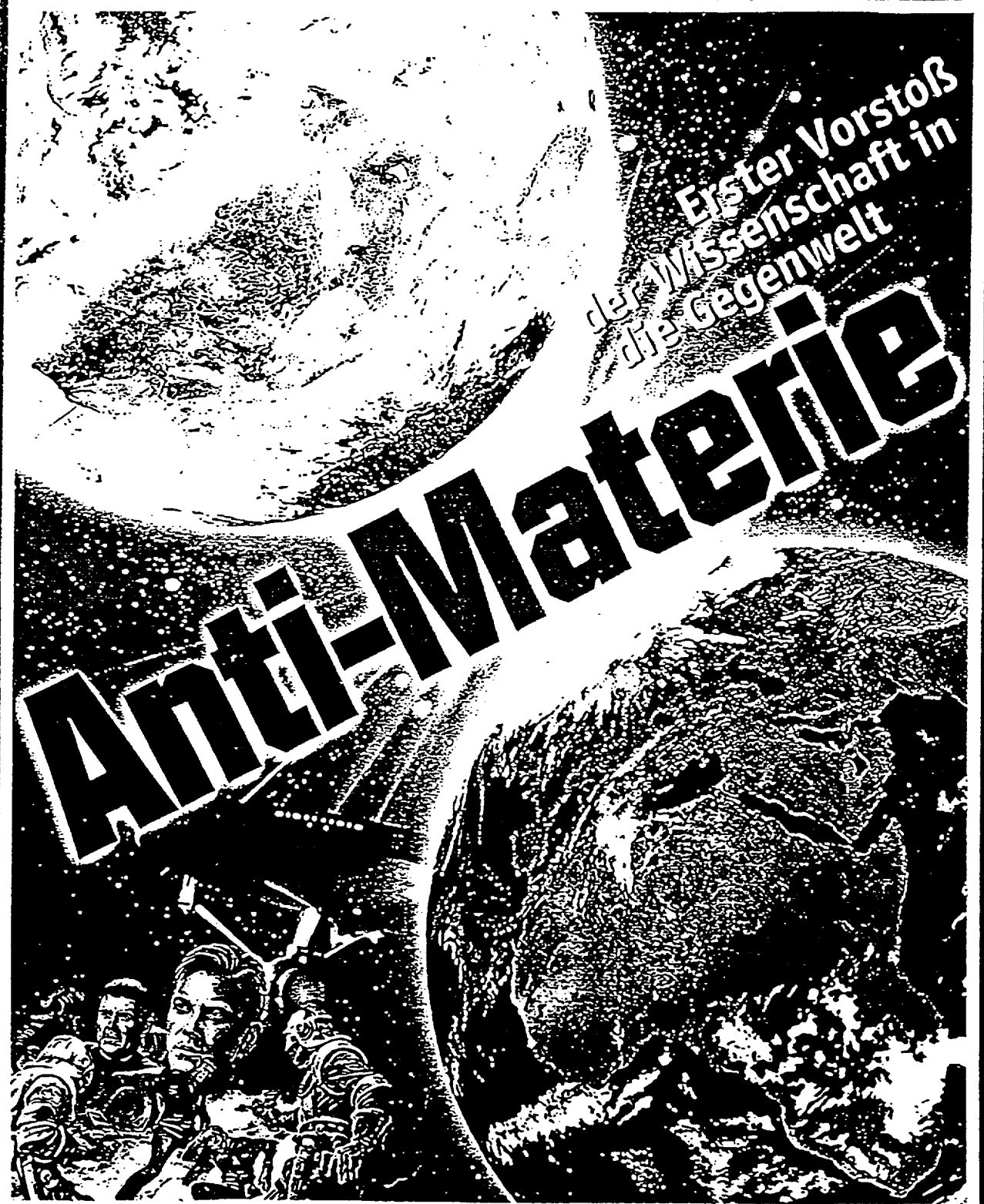

Erster Vorstoß  
der Wissenschaft in  
die Gegenwelt

# Anti-Materie



# Liberation

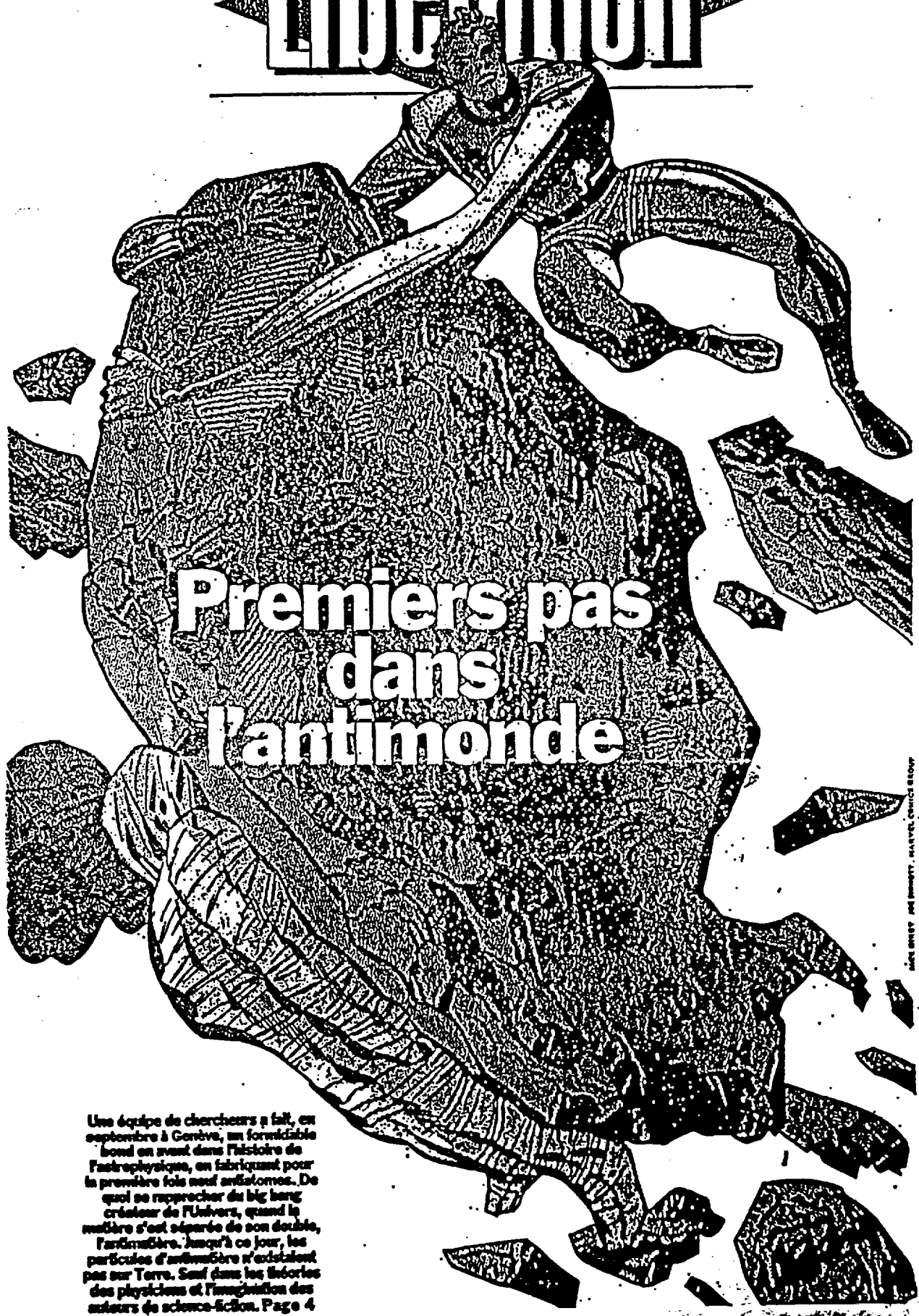

## Premiers pas dans l'antimonde

Une équipe de chercheurs a fait, en septembre à Genève, un formidable bond en avant dans l'histoire de l'astrophysique, en fabriquant pour la première fois neuf antiprotons. De quoi se rapprocher du big bang créateur de l'Univers, quand la matière s'est séparée de son double, l'antimatière. Jusqu'à ce jour, les particules d'antimatière n'existaient pas sur Terre. Seul dans les théories des physiciens et l'imagination des auteurs de science-fiction. Page 4

# LETTERS TO THE EDITOR

The Financial Times

January 20-21, 1996

## Antimatter bombs devastating, but very unlikely ever to be produced

From Mr John Eades.

Sir, I fully agree with all Professor Joseph Rotblat's remarks about the social accountability of scientists (Private View, January 13/14), but the one about antimatter bombs thousands of times more devastating than the fission bomb really needs to be put in context.

First, no antimatter is available on, in, or near the earth, nor in our galaxy or its neighbours. It has to be produced in the laboratory, at ruinous cost for anything but the ludicrously small quantity needed for basic research. At currently practical production rates, it would take ten thousand times the age of the universe to accumulate the explosive power of a single large nuclear bomb.

When this is said, the legitimate argument is usually made: "Ah yes, but you haven't taken future

improvements into account".

Indeed, a hundred billion-fold improvement *would* bring the figure down to something a little less than the period of recorded history.

Can such enormous

"improvements" be ruled out for ever and ever? No, but as the physicist Richard Feynman once said, "it is scientific only to say what is more and what is less likely, and not to be always trying to prove the possible and the impossible". Prof Rotblat is quite correct in saying that a scientist can see earlier than the public what his work might lead to, but then he can also see what it very, very probably won't lead to.

John Eades,  
5 Chemin Ed. Rochat,  
1217 Meyrin,  
Geneva, Switzerland

**S**CIENTISTS ANNOUNCE THE DISCOVERY OF ANOTHER FORM  
OF MATTER/ANTI-MATTER...

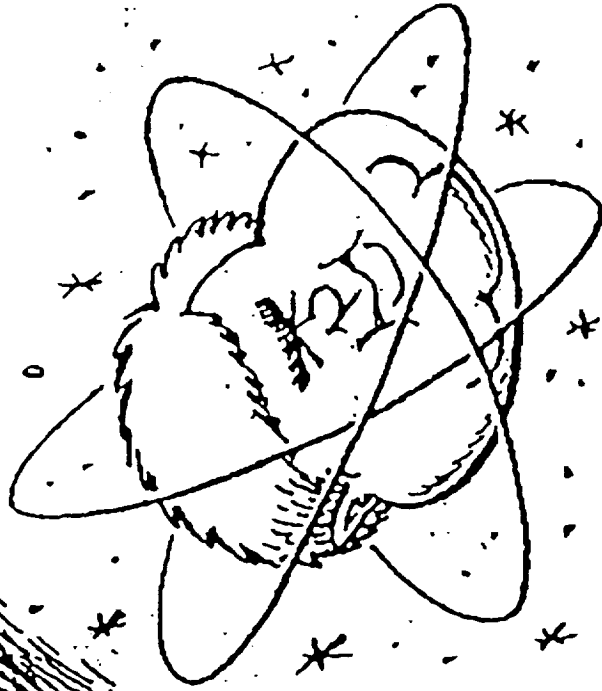

THE NEWTRINO

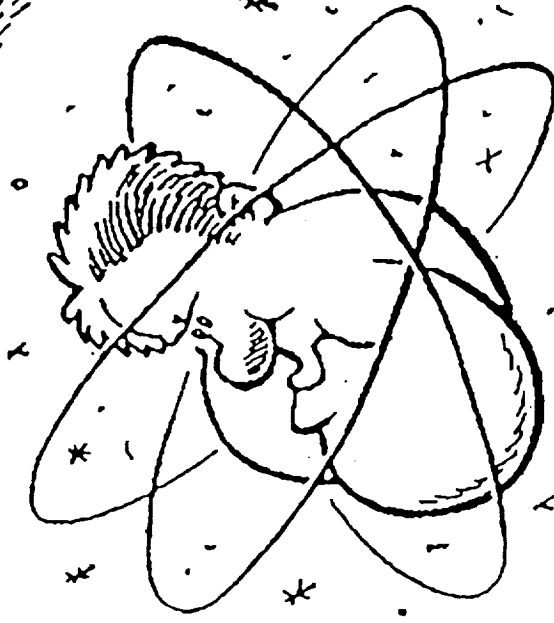

THE CLINTRON

...WHICH, WHEN COMBINED, PRODUCES ABSOLUTELY NO ENERGY.

# Scientists Find Antimatter Fountain Gushing From Center of Milky Way

By Kathy Sawyer  
Washington Post Staff Writer  
Tuesday, April 29, 1997; Page A06

## THE HEART OF THE MATTER

Scientists have detected emissions of gamma rays indicating the presence of a huge fountain of antimatter shooting out from the center of our galaxy. An illustration of the fountain is shown below on the portion of the Milky Way containing the galactic center.

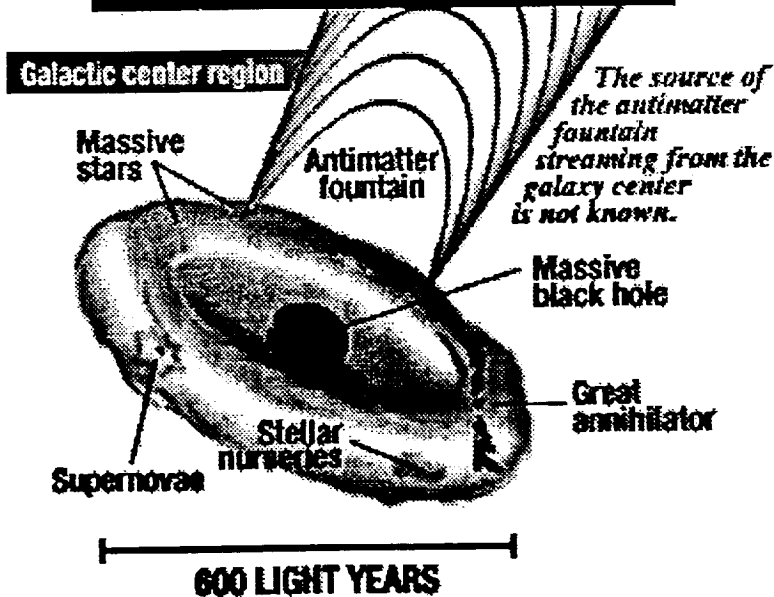
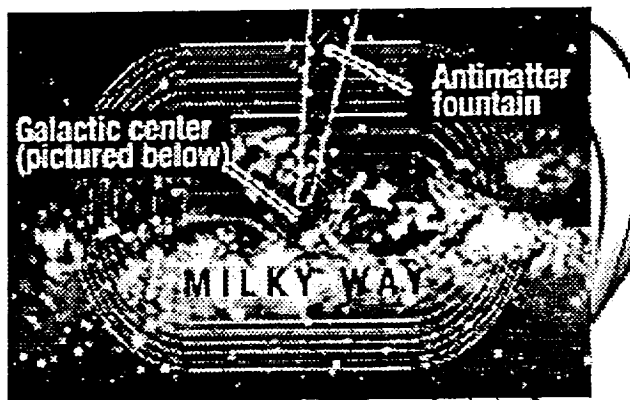

(Richard Furno/The Washington Post)

# What is Antimatter?

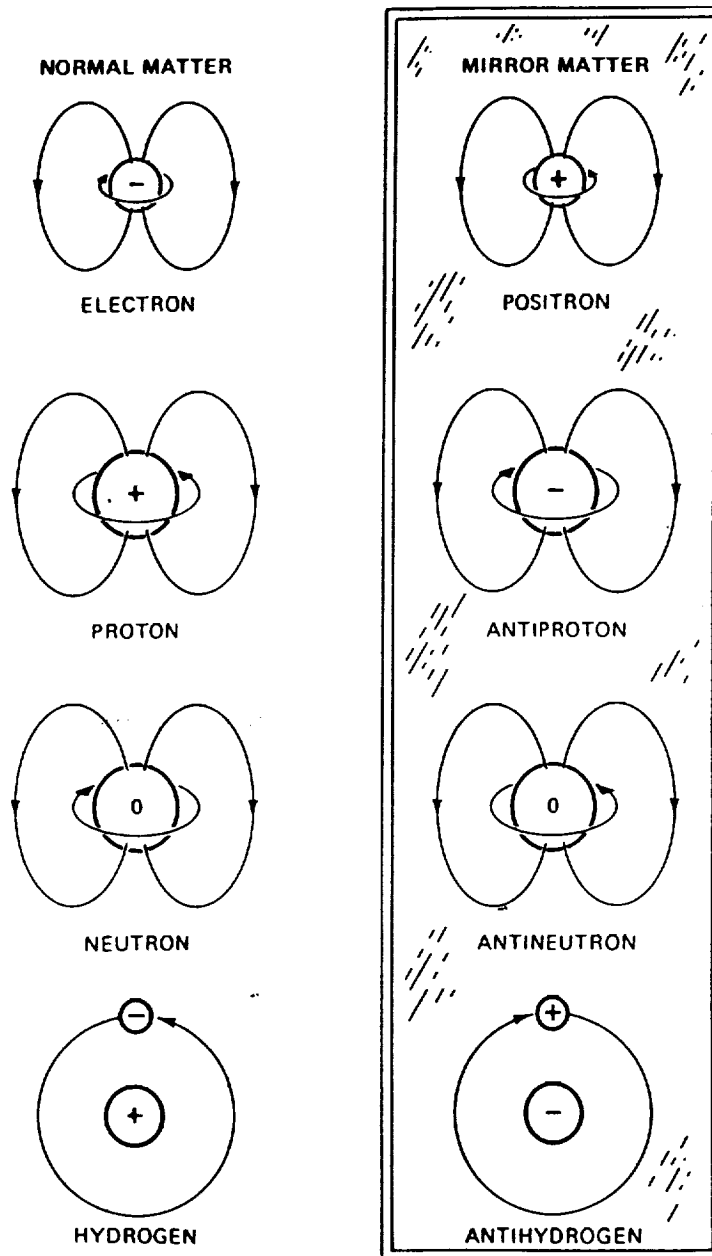

**Figure 1-1** An imaginary "magic mirror" shows the difference between normal matter and antimatter (or "mirror matter"). Charge and "handedness" or parity are reversed for positrons and antiprotons. Handedness is reversed for antineutrons. An antihydrogen antiatom would be made of a positron orbiting an antiproton.

QUARKS } STANDARD  
 + MODEL  
 LEPTONS }

TABLE 1.1 Quarks

Quarks		Antiquarks	
$Q/ e  = +\frac{2}{3}$	$u, c, \dots, t$	$Q/ e  = -\frac{2}{3}$	$\bar{u}, \bar{c}, \dots, \bar{t}$
$Q/ e  = -\frac{1}{3}$	$d, s, b$	$Q/ e  = +\frac{1}{3}$	$\bar{d}, \bar{s}, \bar{b}$

$u = \text{"up" quark}$ $d = \text{"down" quark}$	$\left. \vphantom{\begin{matrix} u \\ d \end{matrix}} \right\} I = \frac{1}{2} \text{ doublet}$	$m_u \simeq m_d \simeq 350 \text{ MeV}/c^2$ $m_s \simeq 550 \text{ MeV}/c^2$ $m_c \simeq 1800 \text{ MeV}/c^2$ $m_b \simeq 4500 \text{ MeV}/c^2$ $m_t \simeq 182,000 \text{ MeV}/c^2$
$s = \text{"strange"} (S = -1),$ $c = \text{"charmed"} (C = +1)$ $b = \text{"bottom"} (B = -1)$ $t = \text{"top"} (T = +1)$		

TABLE 1.2 Leptons

Leptons				Antileptons			
$Q/ e  = -1$	$e^-$	$\mu^-$	$\tau^-$	$Q/ e  = +1$	$e^+$	$\mu^+$	$\tau^+$
$Q/ e  = 0$	$\nu_e$	$\nu_\mu$	$\nu_\tau$	$Q/ e  = 0$	$\bar{\nu}_e$	$\bar{\nu}_\mu$	$\bar{\nu}_\tau$

$m_e =$	0.511 MeV/c <sup>2</sup>
$m_\mu =$	105.6 MeV/c <sup>2</sup>
$m_\tau =$	1870 MeV/c <sup>2</sup>

# PRODUCTION OF ANTIPROTONS

# How is Antimatter Confined?



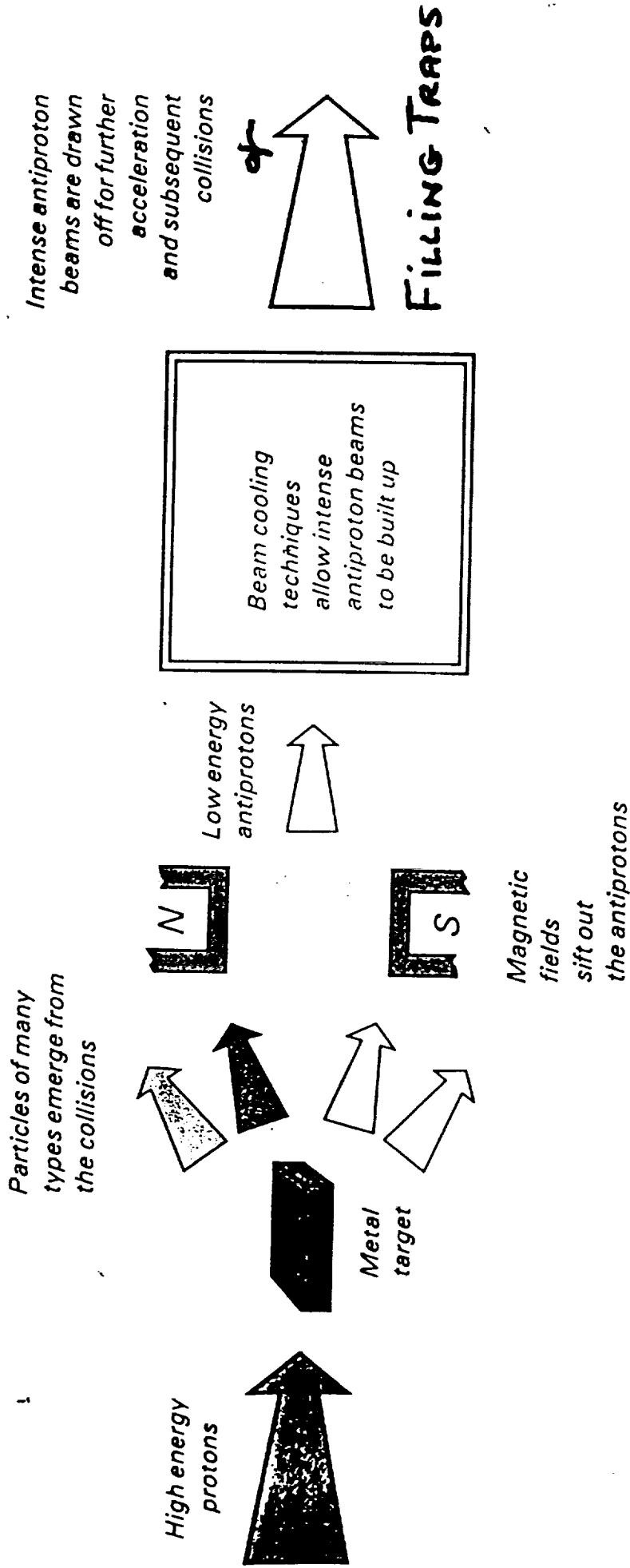

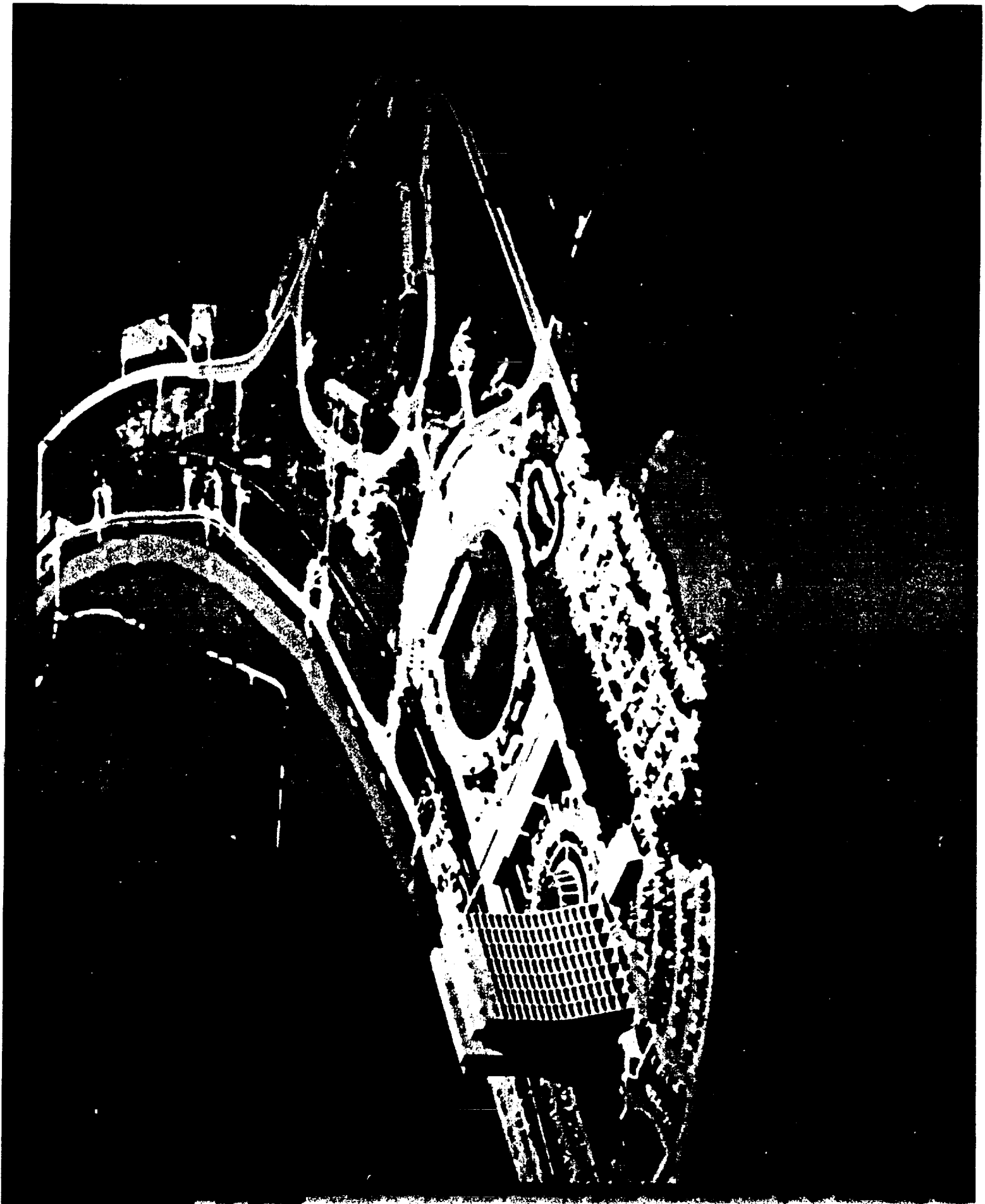

# ANTIPROTON PRODUCTION (FERMILAB)

10

1996:  $6 \times 10$  /hr. stacked in the Accumulator;  
-----> 0.87 ng/yr.

1998: With completion of the Main Injector;  
-----> 15 ng/yr.

2000: New Accumulator planned;  
-----> 150 ng/yr.

Beyond: New (unproven) technologies, e.g.  
plasma mirror concept--> 1500 ng/yr.

# TRAPPING OF ANTIPROTONS

PROPOSAL TO THE CERN SPSL COMMITTEE

**CAPTURE, ELECTRON-COOLING, AND COMPRESSION  
OF ANTIPROTONS IN A LARGE PENNING TRAP  
AND PHYSICS EXPERIMENTS  
WITH AN ULTRA-LOW ENERGY EXTRACTED ANTIPROTON BEAM.**

M. H. Holzscheiter<sup>1\*</sup>, M. Charlton<sup>2</sup>, T. W. Darling<sup>1</sup>, X. Feng<sup>3</sup>, T. Goldman<sup>1</sup>,  
D. Hajdukovic<sup>4</sup>, G. Laricchia<sup>2</sup>, V. Lagomarsino<sup>5</sup>, N. S. P. King<sup>1</sup>, R. A. Lewis<sup>6</sup>,  
G. Manuzio<sup>5</sup>, J. Merrison<sup>3</sup>, G. L. Morgan<sup>1</sup>, M. M. Nieto<sup>1</sup>, R. Ristinen<sup>7</sup>, J. Rochet<sup>6</sup>,  
M. M. Schauer<sup>1</sup>, G. A. Smith<sup>6</sup>, G. Testera<sup>5</sup>, F. C. Witteborn<sup>8</sup>, Y. Yamazaki<sup>9</sup>

# PS200

\*) Spokesperson for the PS200 Collaboration

- 
- 1) Los Alamos National Laboratory, Los Alamos, NM 87545, USA
  - 2) Dep. of Phys.& Astr., University College London, Gower Street, London WC1E 6BT, UK
  - 3) University Aarhus, Det Fysik Institut, DK-8000 Aarhus-C, Denmark
  - 4) CERN, Division PPE, CH-1211 Geneva, Switzerland
  - 5) INFN Genova, Via Dodecaneso 33, I-16146 Genova, Italy
  - 6) Penn State University, University Park, PA 16802, USA
  - 7) University of Colorado, Boulder, CO 80309, USA
  - 8) NASA-AMES Research Center, Moffett Field, CA 94035, USA
  - 9) University of Tokyo, Tokyo, JAPAN 153

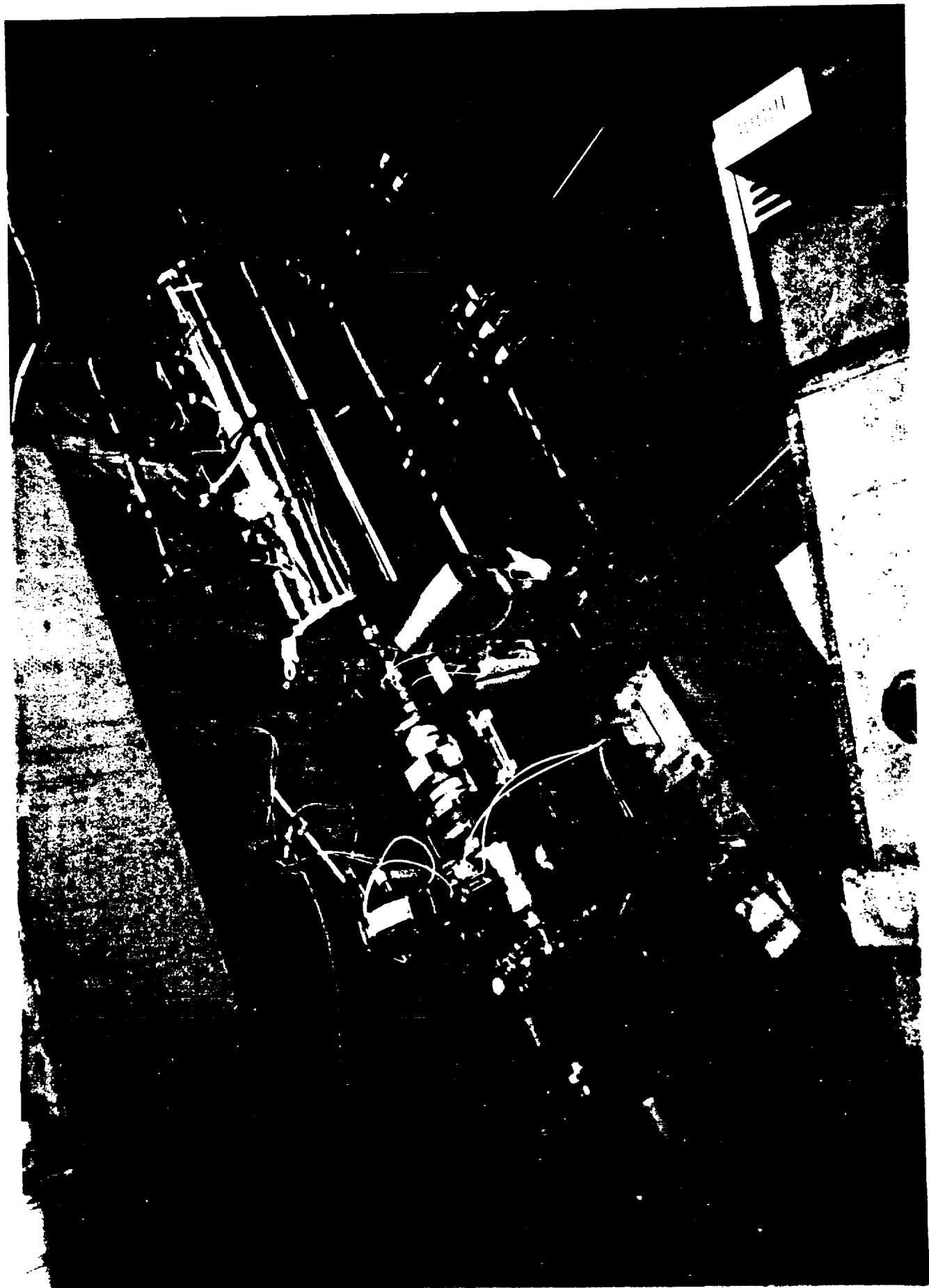

# Catching and Cooling Antiprotons In a Penning Trap

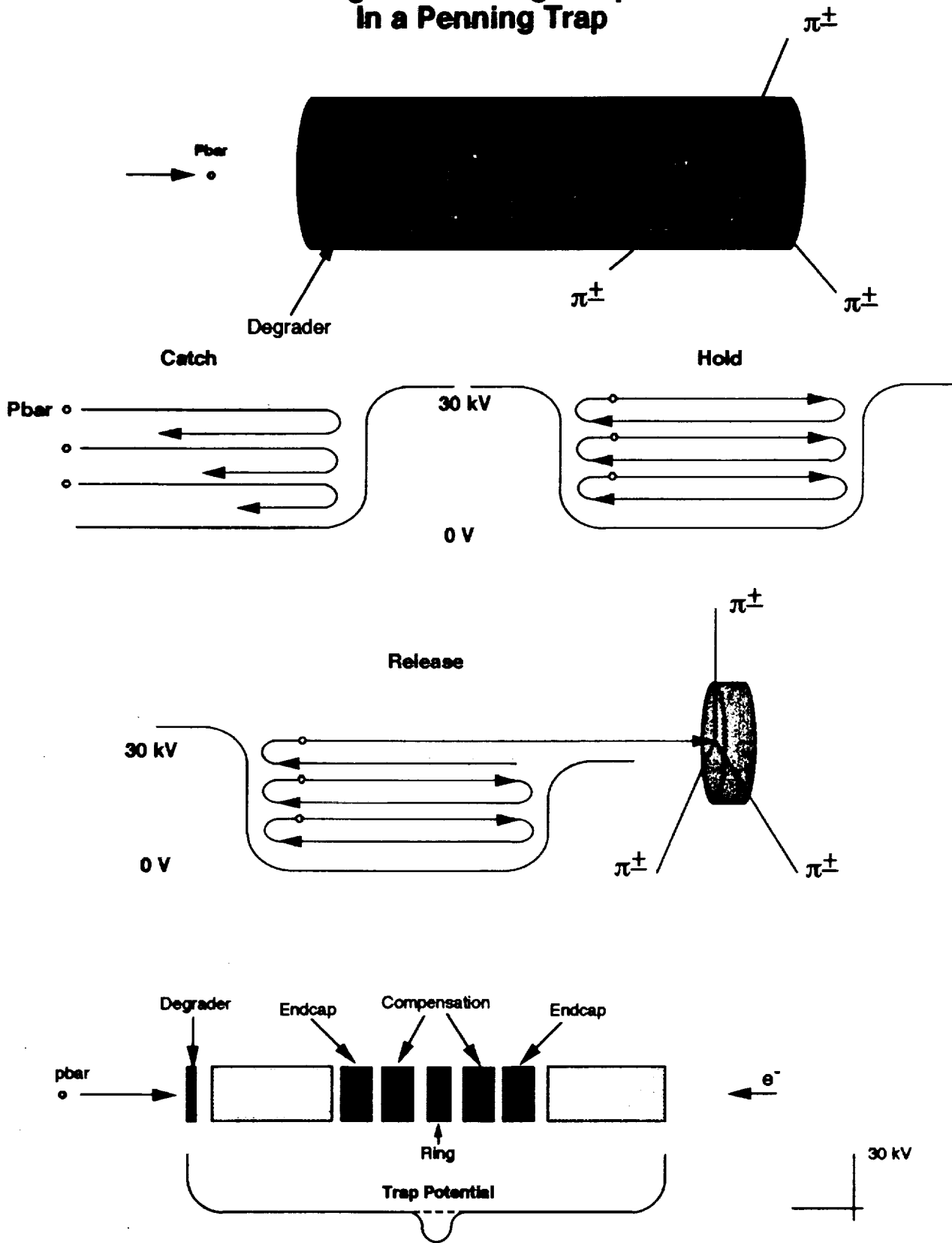

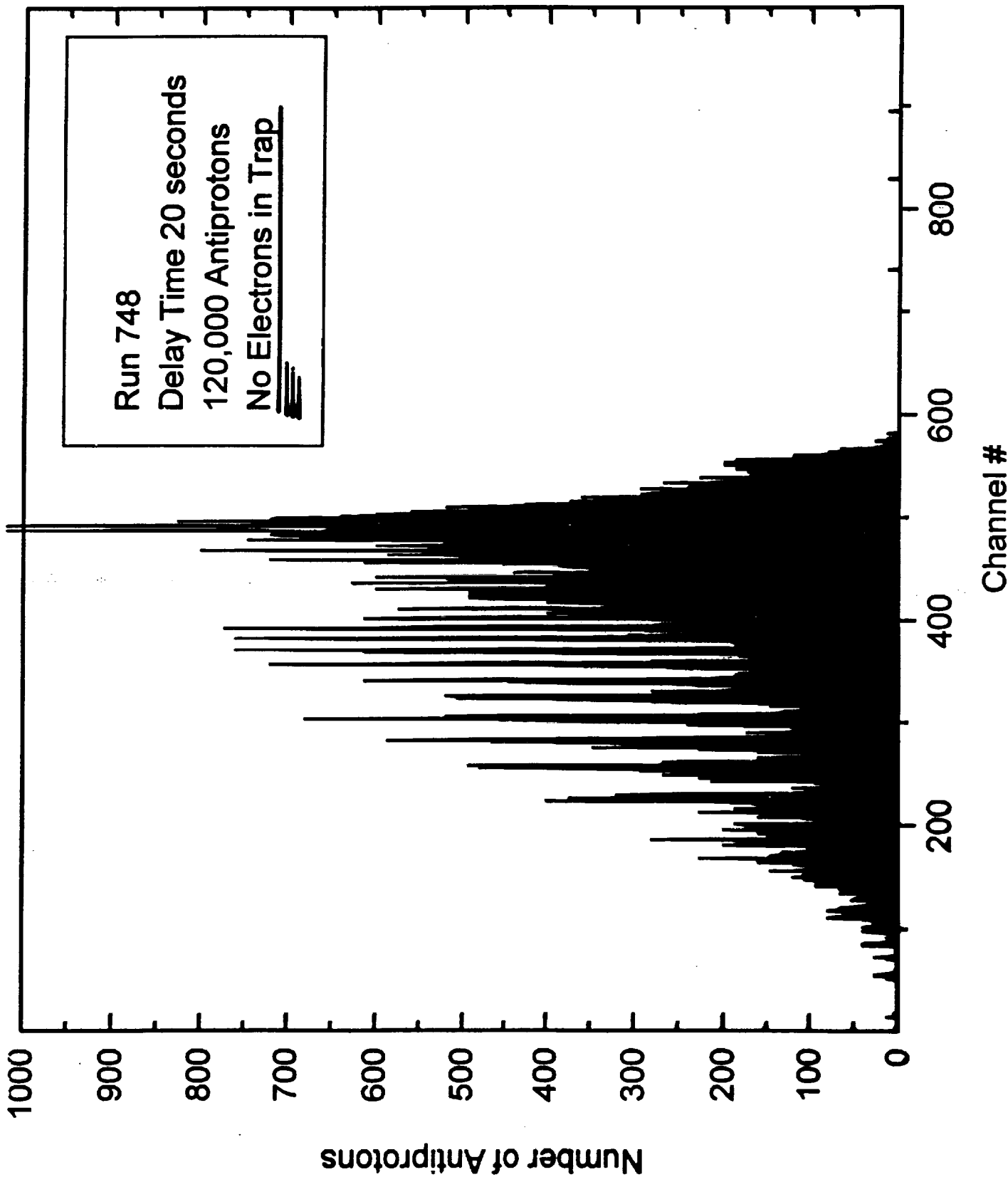

Run 748  
Delay Time 20 seconds  
120,000 Antiprotons  
No Electrons in Trap

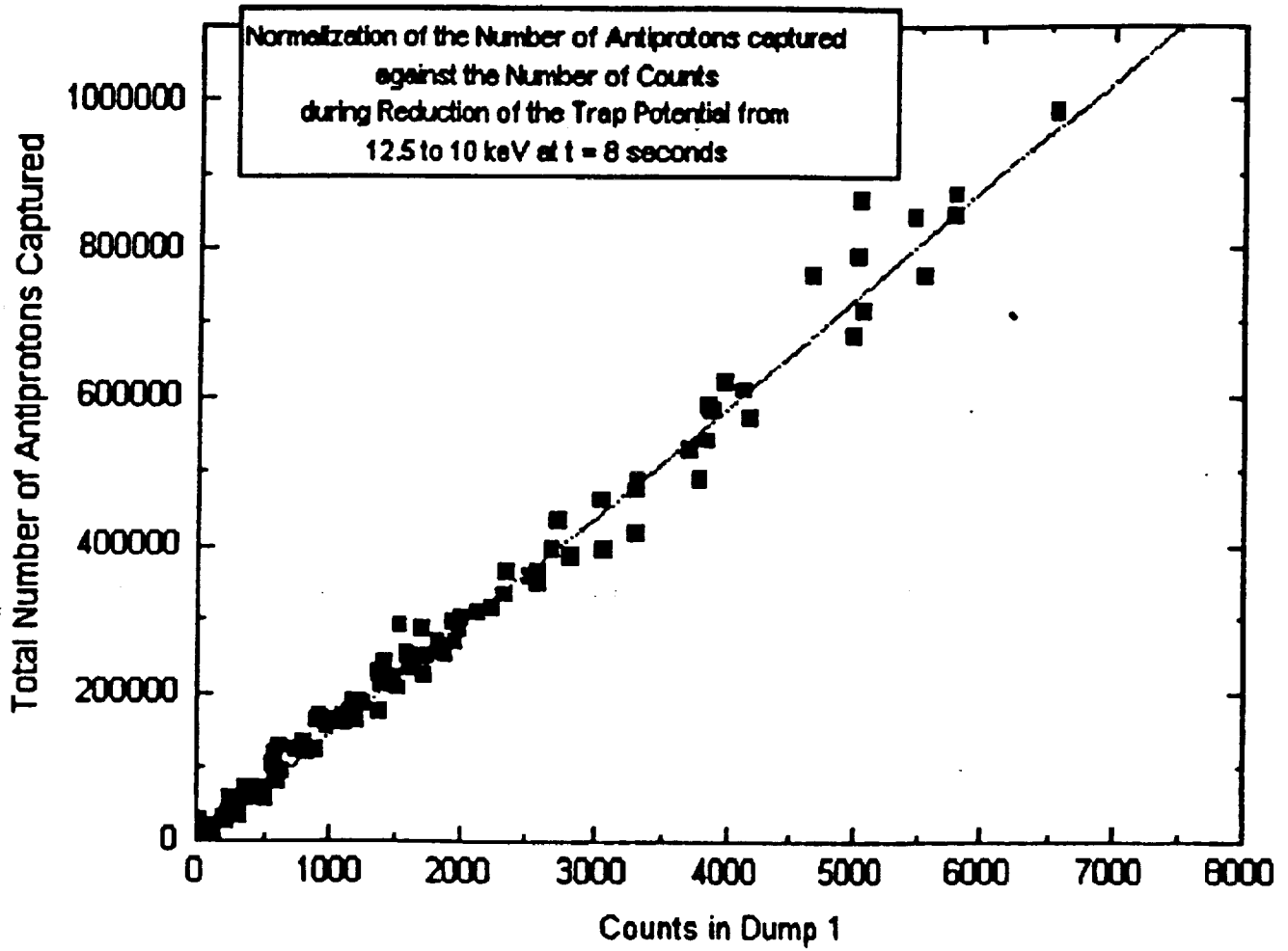
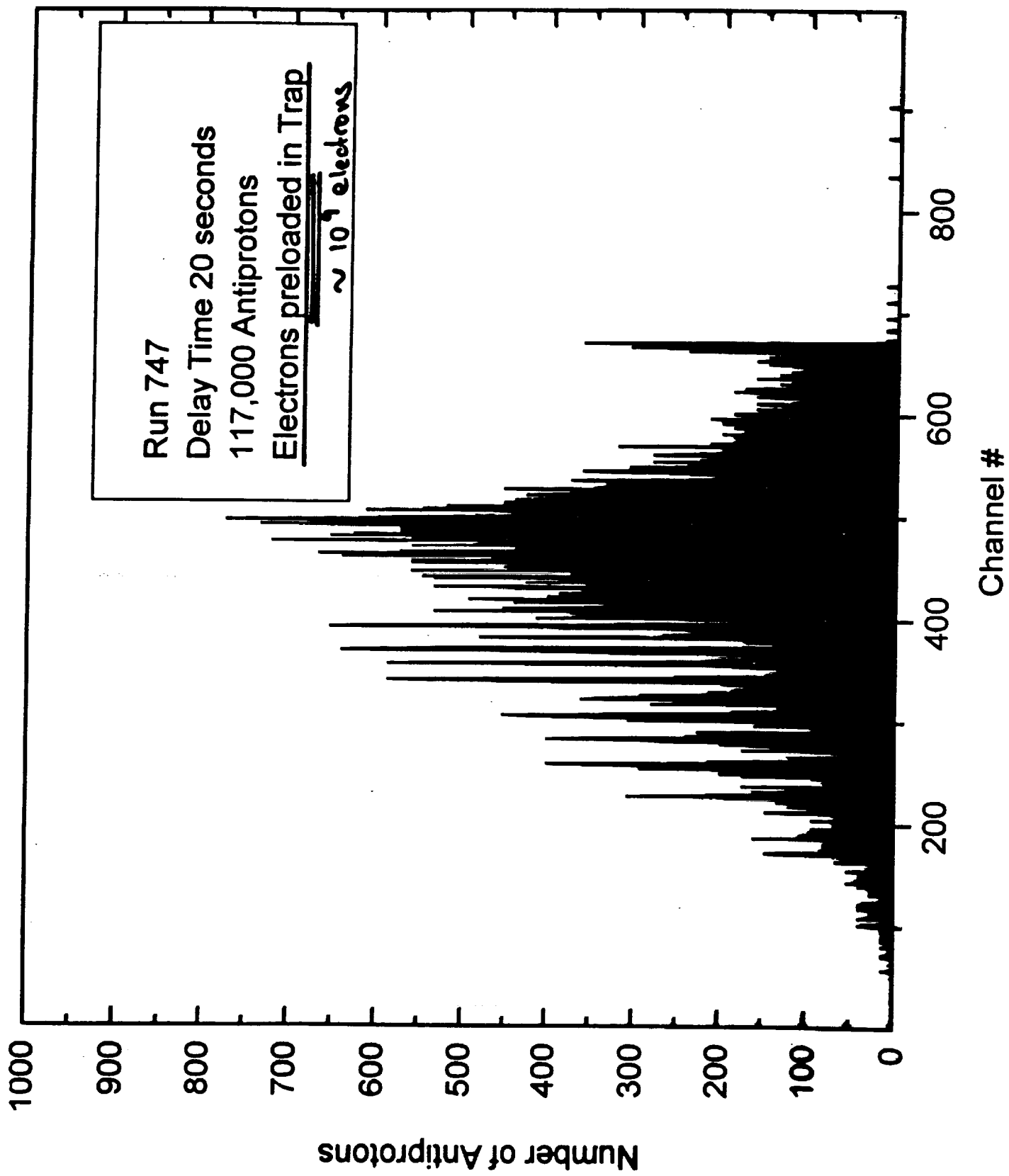

Fig. 2: Normalization of the total number of antiprotons captured.





Run 747

Delay Time 20 seconds

117,000 Antiprotons

Electrons preloaded in Trap  
~ 10<sup>9</sup> electrons

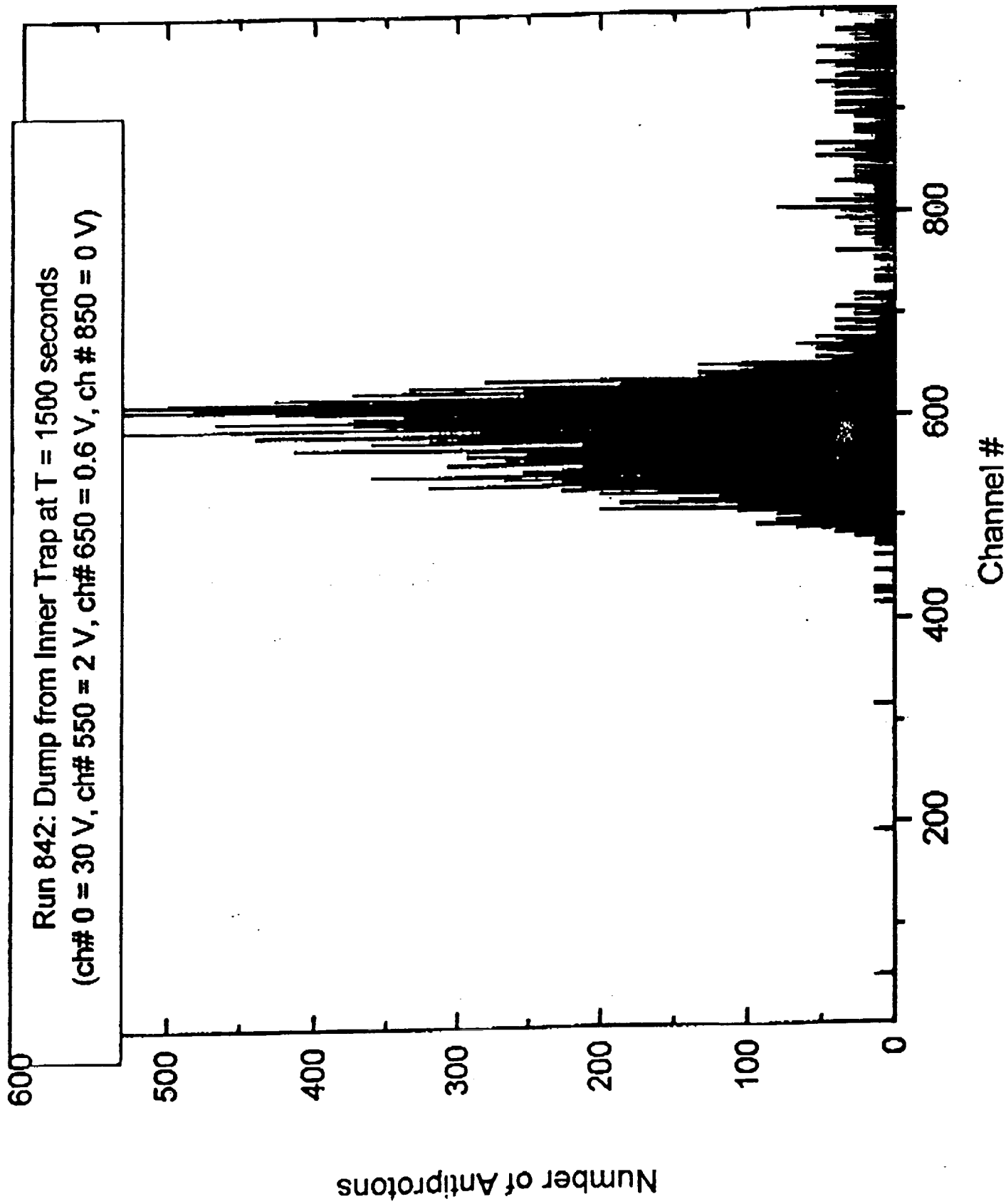

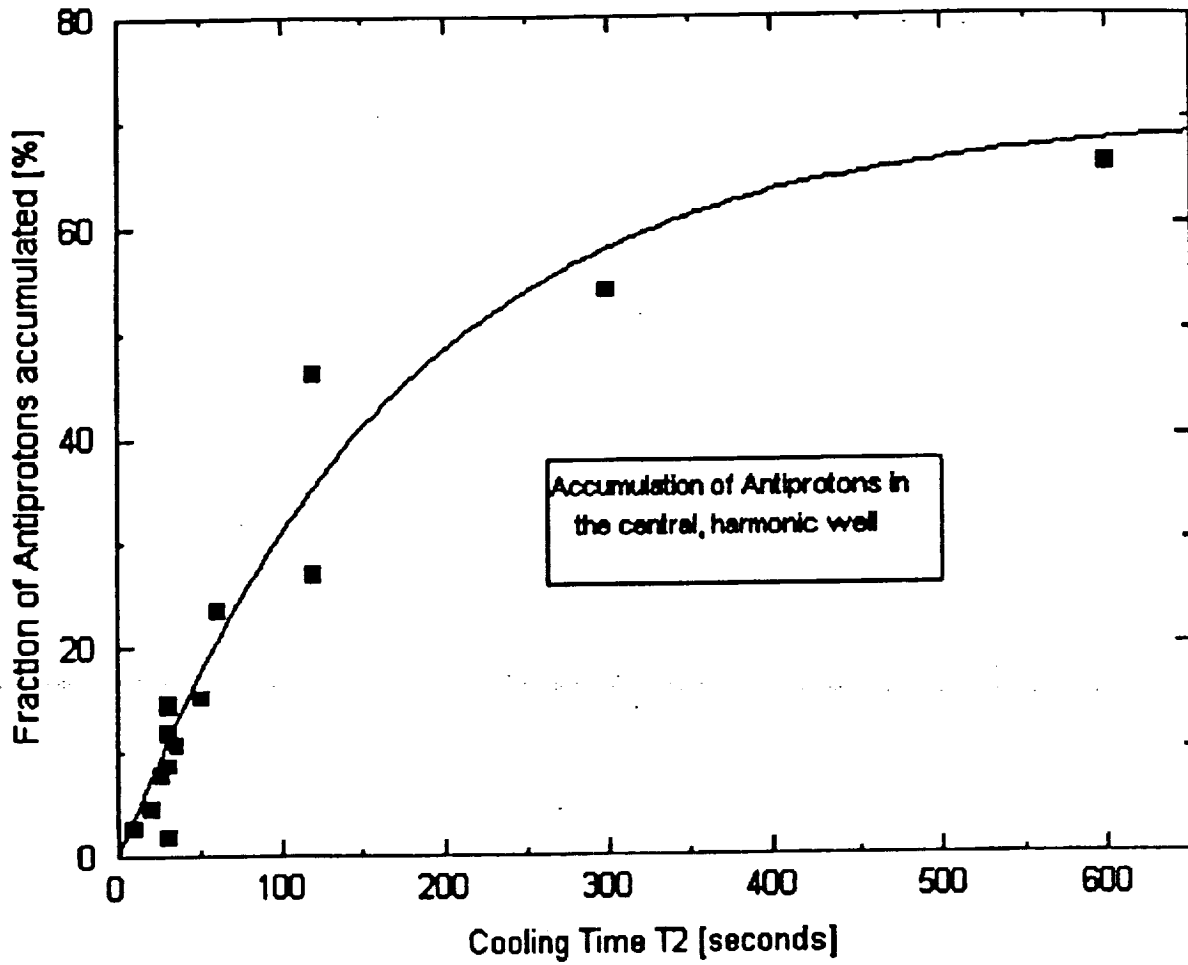

Figure 4: Accumulation of antiprotons in the central well. The solid line is calculated for a time constant of 175 seconds and a maximum accumulation of 70 %

# PHYSICS LETTERS A

---

Physics Letters A 214 (1996) 279–284

## Are antiprotons forever?

M.H. Holzscheiter<sup>a,1</sup>, X. Feng<sup>b,2</sup>, T. Goldman<sup>c,3</sup>, N.S.P. King<sup>a,4</sup>, R.A. Lewis<sup>d,5</sup>,  
M.M. Nieto<sup>c,e,6</sup>, G.A. Smith<sup>d,7</sup>

<sup>a</sup> *Physics Division, Los Alamos National Laboratory, Los Alamos, NM 87545, USA*

<sup>b</sup> *Institute for Physics and Astronomy, University of Aarhus, 8000 Aarhus-C, Denmark*

<sup>c</sup> *Theoretical Division, Los Alamos National Laboratory, Los Alamos, NM 87545, USA*

<sup>d</sup> *Pennsylvania State University, University Park, PA 16802, USA*

<sup>e</sup> *Abteilung für Quantenphysik, Universität Ulm, D-89069 Ulm, Germany*

Received 10 October 1995; revised manuscript received 15 February 1996; accepted for publication 16 February 1996

Communicated by B. Fricke



ELSEVIER

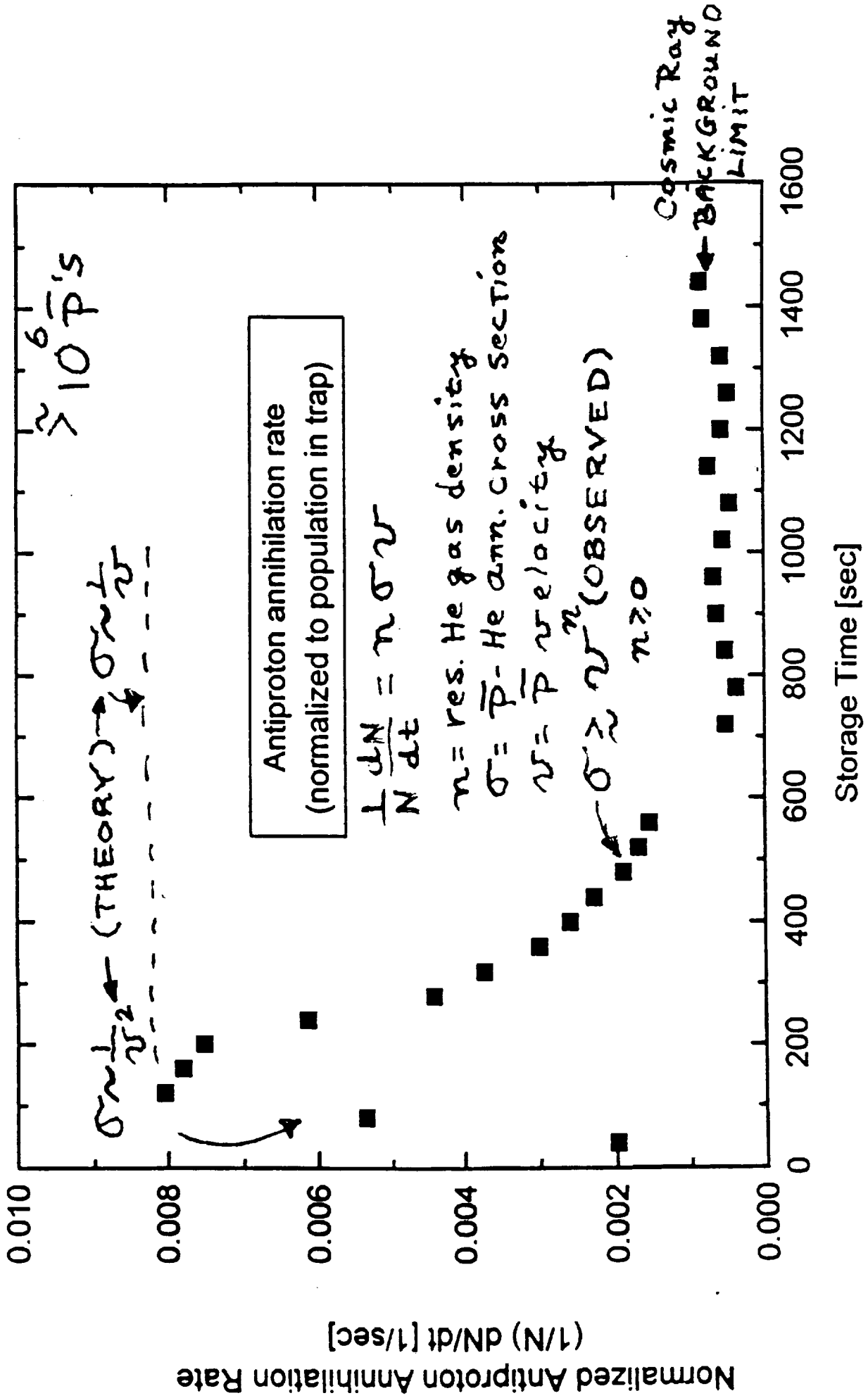

Figure 4

INNER VACUUM PRESSURE DETERMINED FROM  
PS200 ANTIPROTON LIFETIME MEASUREMENTS

$\text{novt} = 1$  (exponential loss)

1.  $\tau > 1500$  sec. (Are Antiprotons Forever, PL A214, 279, 1996).
2.  $\sigma_{\text{neutral helium}} = 10^{-16}$  cm<sup>2</sup> (H. Bethe, private communication; W.R. Gibbs, Phys. Rev. A 56, 3553, 1997).
3.  $v = 1.4 \times 10^6$  cm/sec ( $E_{\text{pbar}} = 1$  eV).

----->  $n < 4.8 \times 10^8$  cm<sup>-3</sup>

----->  $p < 2 \times 10^{-10}$  torr @ 4.5 K

## Low-energy antiproton interaction with helium

W. R. Gibbs

New Mexico State University, Las Cruces, New Mexico 88003

(Received 24 March 1997; revised manuscript received 10 June 1997)

An *ab initio* potential for the interaction of the neutral helium atom with antiprotons and protons is calculated using the Born-Oppenheimer approximation. Using this potential, the annihilation cross section for antiprotons in the energy range  $0.01 \mu\text{eV}$  to  $1 \text{ eV}$  is calculated. [S1050-2947(97)00311-9]

PACS number(s): 36.10.Dr, 34.10.+x

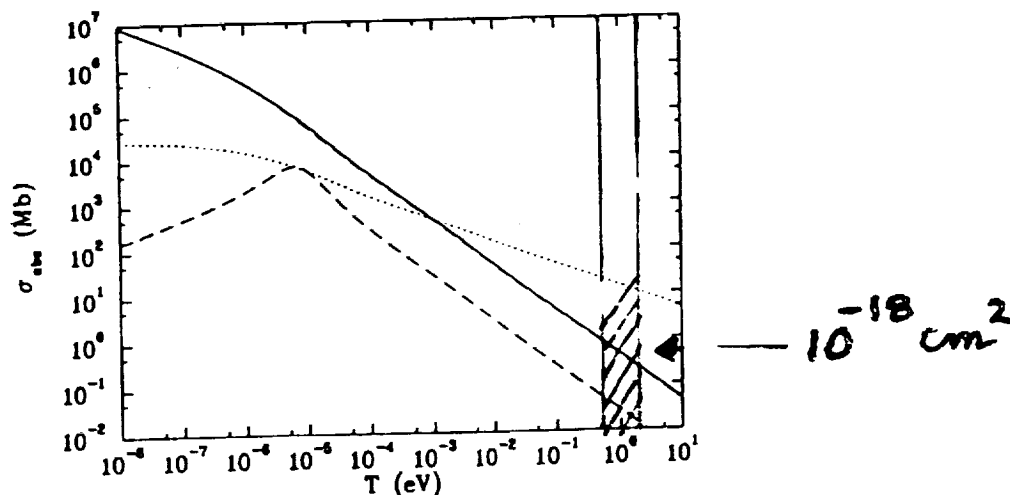

FIG. 7. Annihilation cross section for antiprotons incident on neutral helium atoms. The solid curve gives the result due to the sum of all partial waves while the separate dashed curve gives the  $p$ -wave contribution. The dashed curve almost coincident with the solid curve represents the  $s$ -wave contribution alone. The dotted curve gives the product of the velocity and the cross section normalized to the cross section (proportional to the annihilation rate) at  $1 \text{ meV}$ .

## Trapped antimatter holds on to life

THE antiworld may not be so fragile after all. Conventional wisdom says that antimatter and matter should rapidly annihilate each other, releasing a burst of energy. But physicists from the US and Denmark have now found that antiprotons can survive for much longer than expected in the presence of ordinary atoms.

The new discovery should make it much easier to study "bottled" antiprotons. "[We] require some mechanism of collection and storage of antimatter," says Michael Holzschneider of the Los Alamos National Laboratory in New Mexico, who led the new research. But if antimatter does not always annihilate readily, designing propulsion systems based on its annihilation may not be as straightforward as some science fiction writers suggest.

Antiprotons, the antimatter partners of protons, are produced in a machine called the Low Energy Antiproton Ring (LEAR) at CERN, the European centre for particle physics in Geneva. LEAR has already been used to create the first antiatoms (This

Week, 6 January), and physicists are now working on an experiment called PS-200 to store antiatoms, and to test a theory of Albert Einstein's called the equivalence principle. This states that gravity should have exactly the same effect on antimatter as on matter.

To measure the effects of the Earth's gravity on antiprotons, the PS-200 team needs to slow them down from the near-light speeds at which they circle LEAR. To this end Holzschneider's team has developed a trap that confines antiprotons using electric and magnetic fields.

The researchers first slow LEAR's antiprotons by some 95 per cent by passing them through a thin piece of foil at the entrance to the trap. Once they are inside, an electric field switches on, closing the trap. The trapped antiprotons mix with a gas of slow-moving electrons, and after successive collisions with them finish up with speeds of just a few tens or hundreds of metres per second.

A single brief burst of antiprotons from LEAR yielded up to a million slow-moving

antiprotons confined in the volume of a thimble. But the trap also contained a few atoms of helium, with which the antiprotons should have collided and annihilated. Initially, this annihilation proceeded as predicted. But after two and a half minutes, the rate unexpectedly began to decrease.

Eventually, the annihilation rate dropped so low that it could not be separated from the natural background radiation recorded by the team's detectors. In a paper that will appear in the journal *Physics Letters A*, the researchers admit that they have no firm explanation. "The electrons may be shielding the antiprotons from going into the helium nucleus, which they have to do before they can annihilate," says Holzschneider.

Whatever the reason, the finding that, slowed antiprotons are relatively stable means that it should be possible to store antiprotons without the need to keep them at low temperatures using expensive cryogenic equipment, which minimises annihilation. "Antiprotons could then be delivered to laboratories around the world, allowing many different kinds of experiments to be done," says Holzschneider.

Andrew Watson

**'It should be possible to store antiprotons'**



# PORTABLE ANTIPROTON TRAP

# Portable Penning Trap

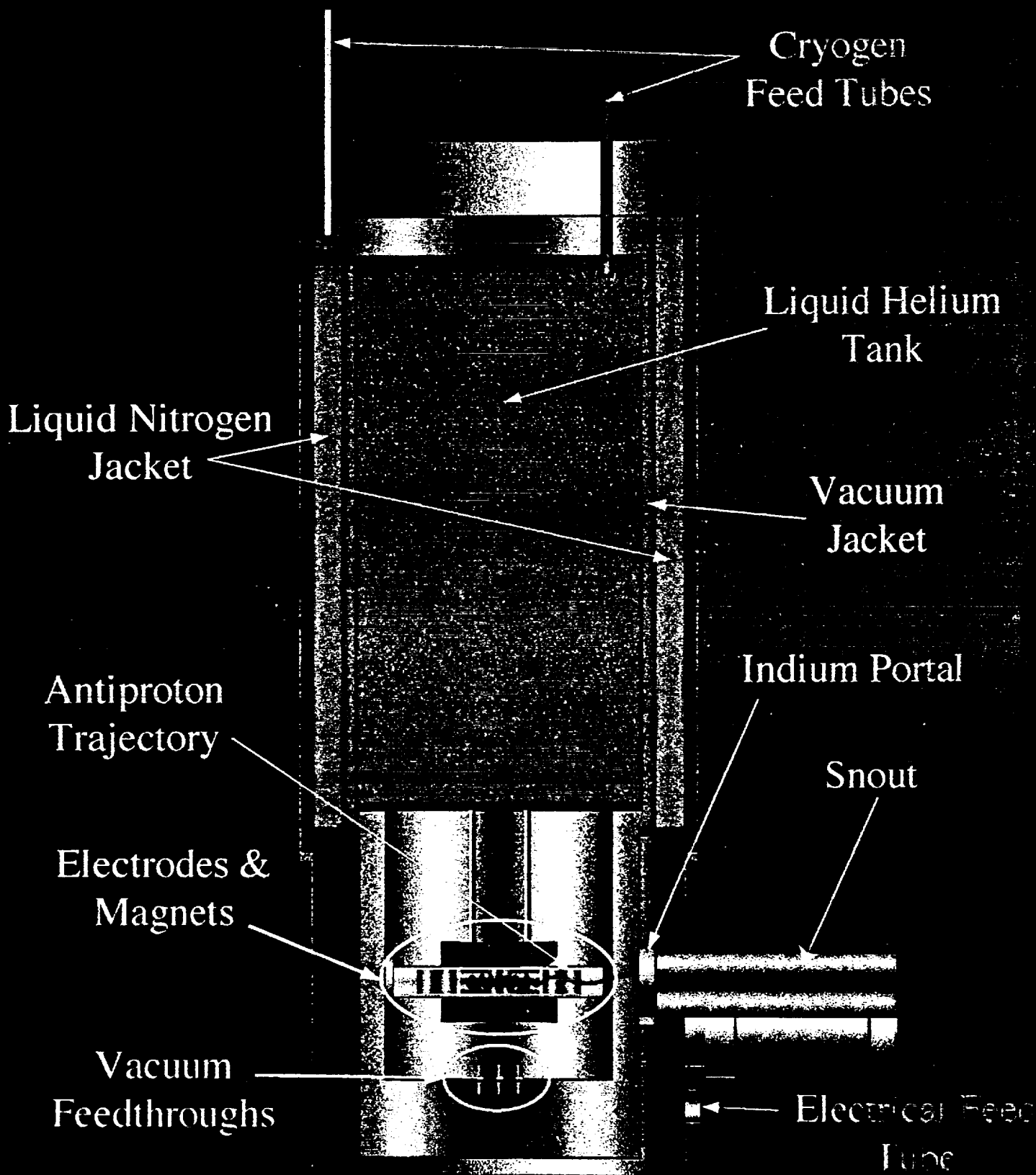

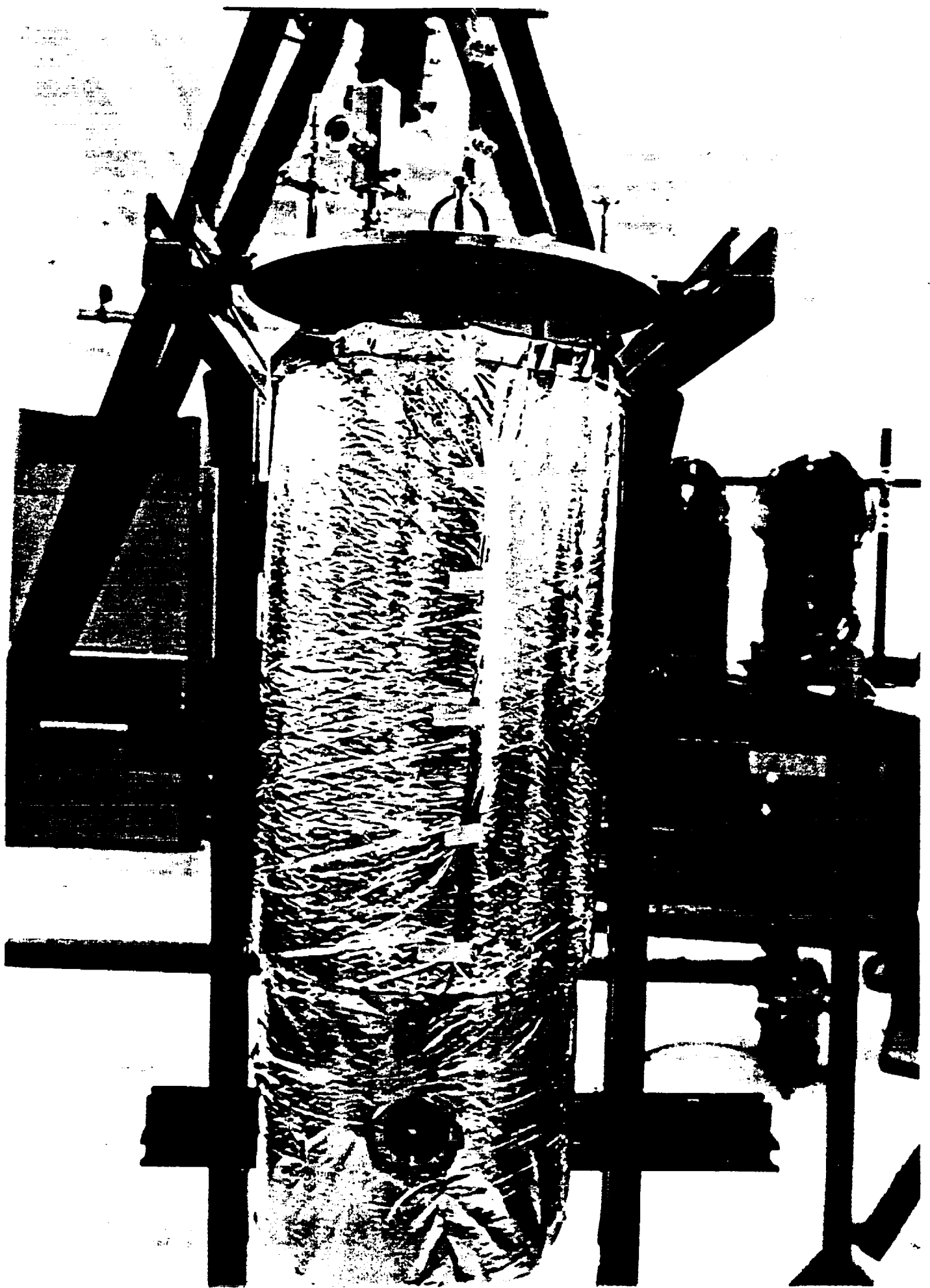

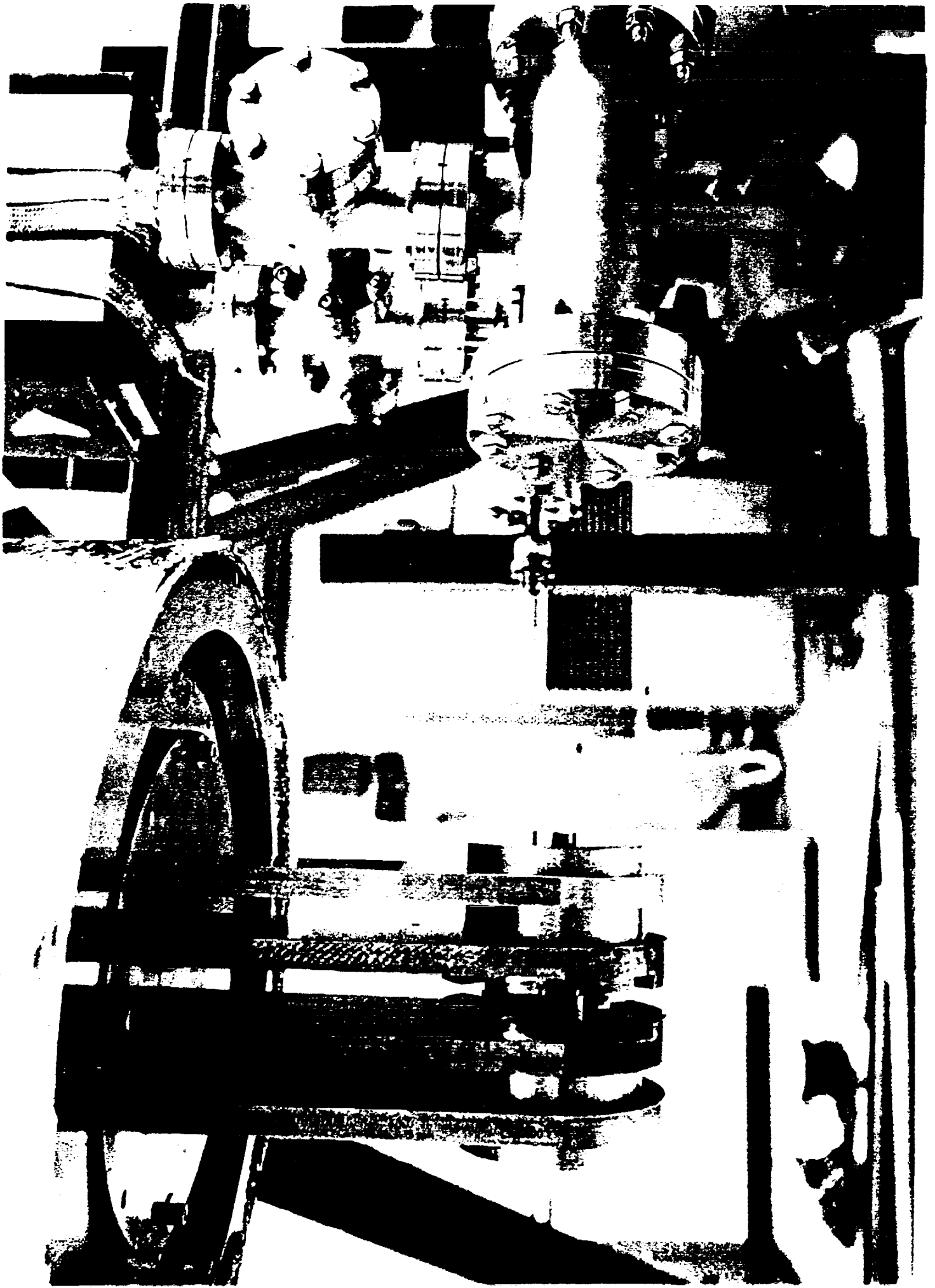

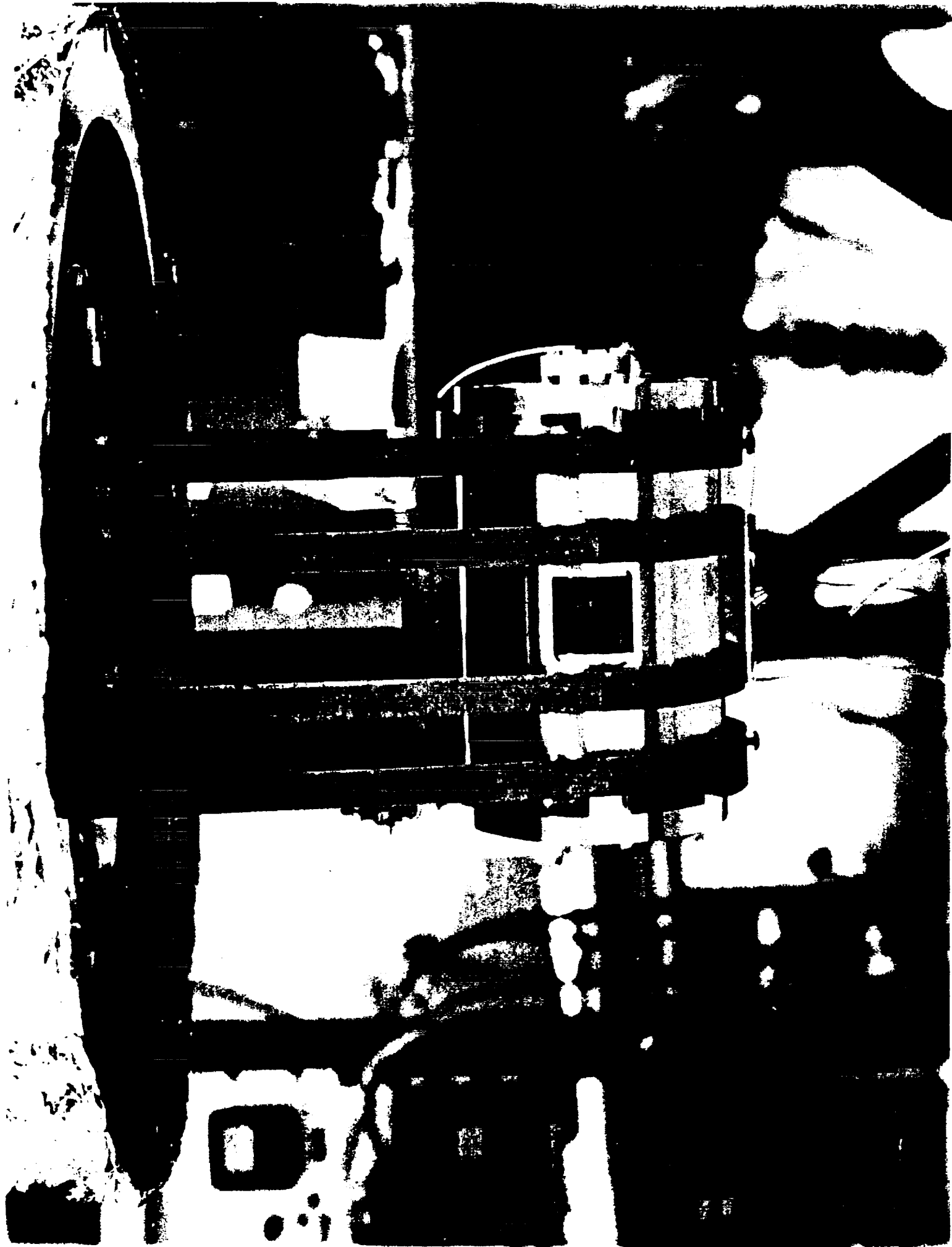

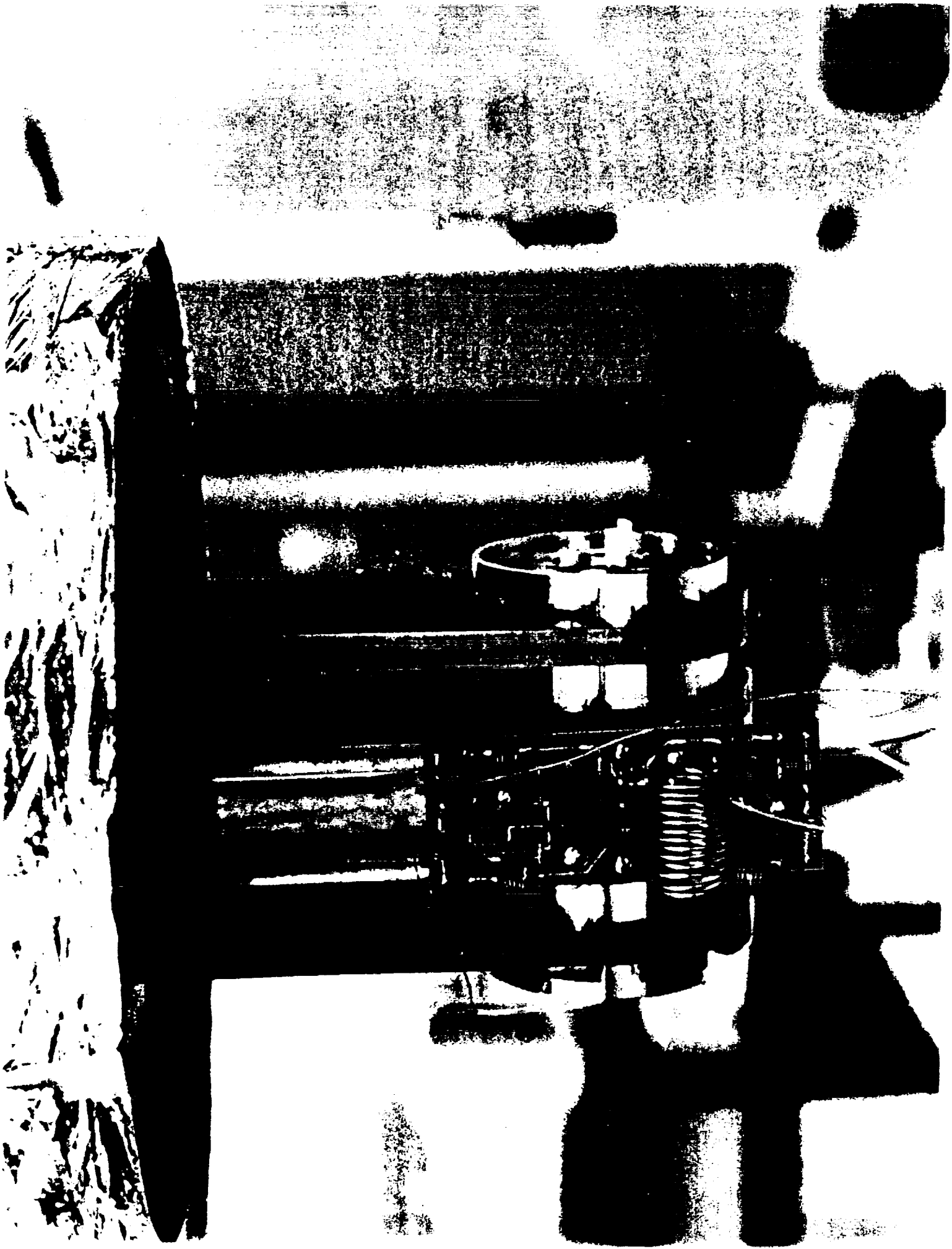

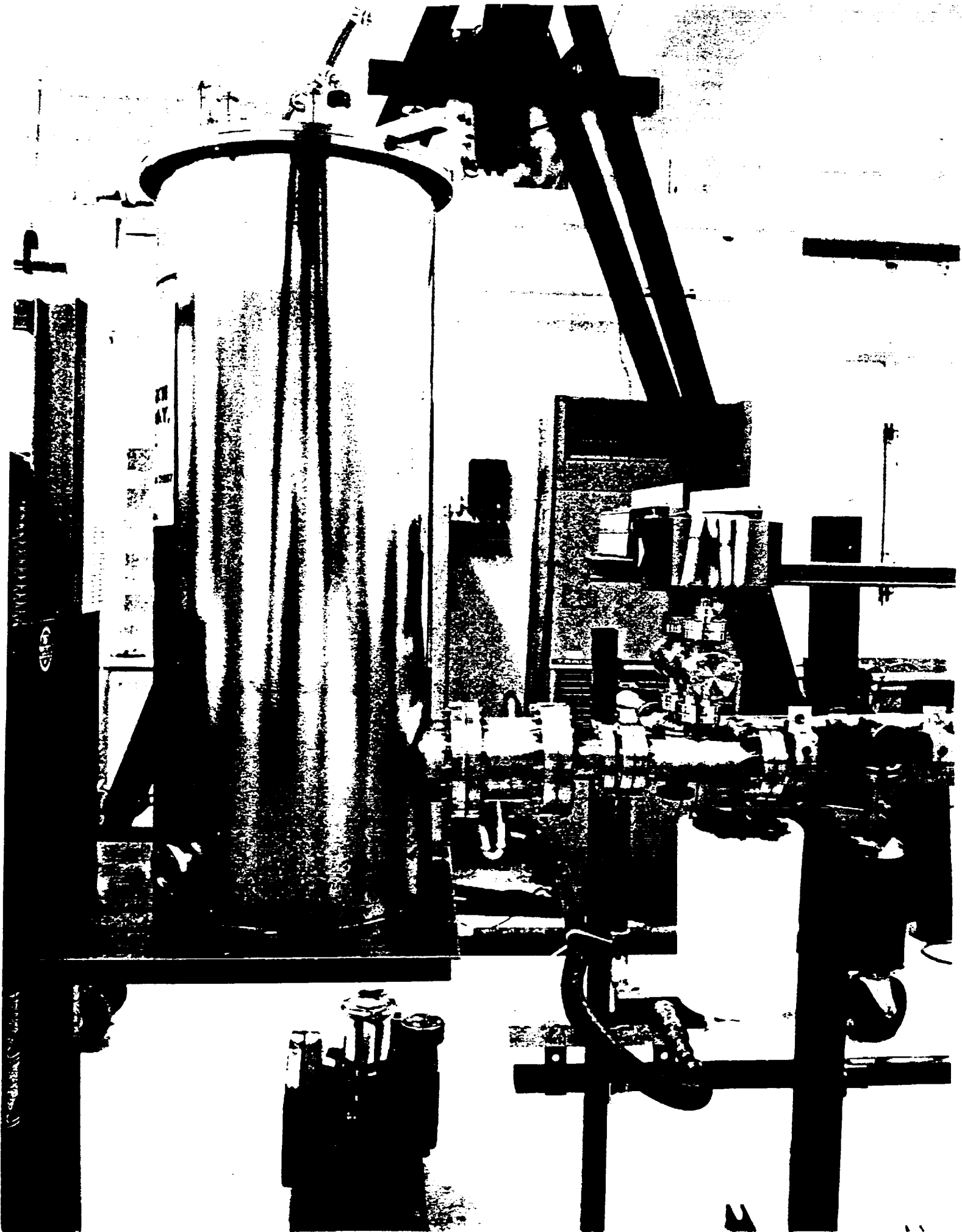

# **ELECTRON TRAPPING**



### Portable trap electrode voltages

Electrode	e <sup>-</sup> storage		H <sup>+</sup> storage		proton extraction:	
	1	2	3	4	loading	dumping
1	-188	-320	320	1200	1200	1200
2	-4.7	-8	8	1005	1005	1005
3	0.0	0	0	1000	1000	1000
4	-4.7	-8	8	1005	0	0
5	-188	-320	320	1200	0	0
6	-188	-320	320	1200	0	0
A	0	0	0	0	410	0
B	0	0	0	0	0	0
C	0	0	0	0	0	0
D	0	0	0	0	410	0
E	0	0	0	0	0	0
F	0	0	0	0	0	0
G	0	0	0	0	0	0
H	0	0	0	0	0	0
I	0	0	0	0	0	0
J	0	0	0	0	0	640

### Electrode structure

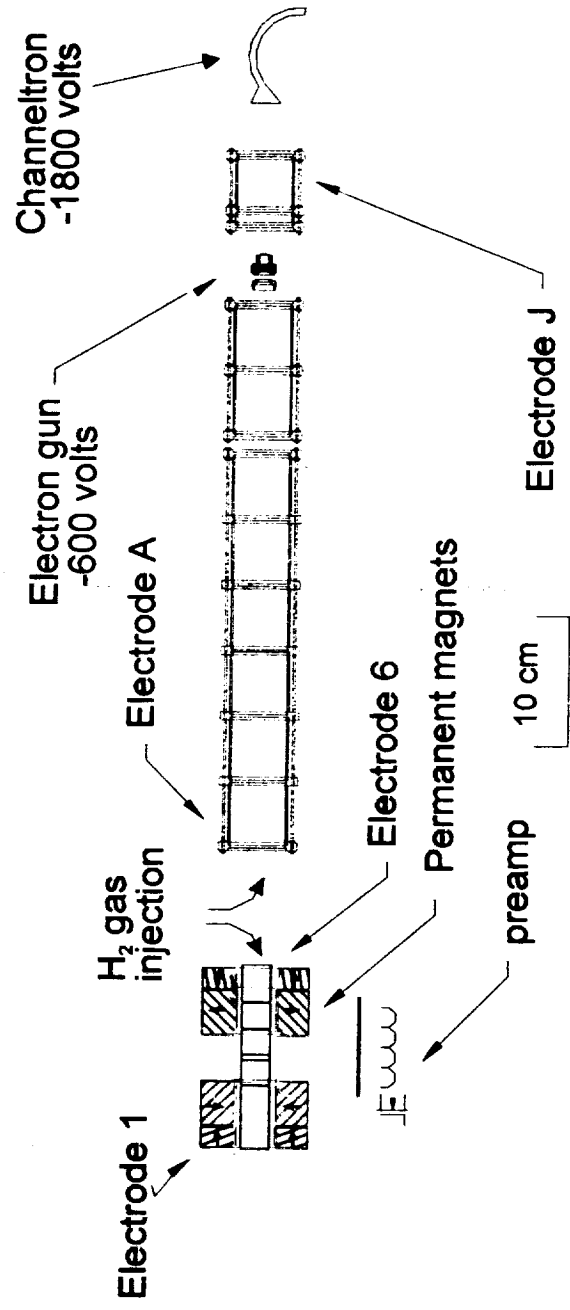
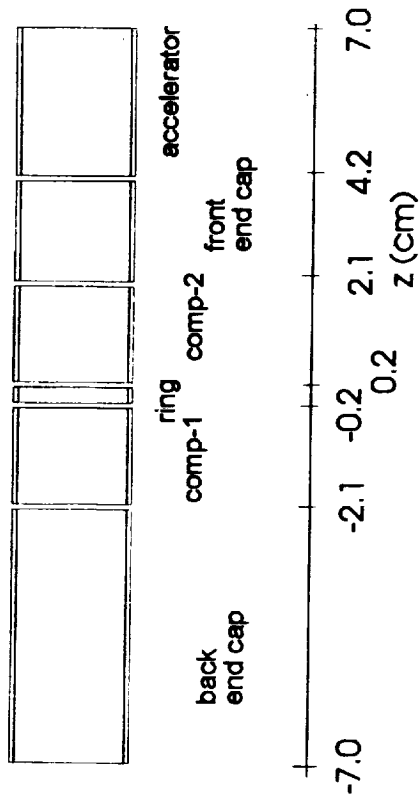

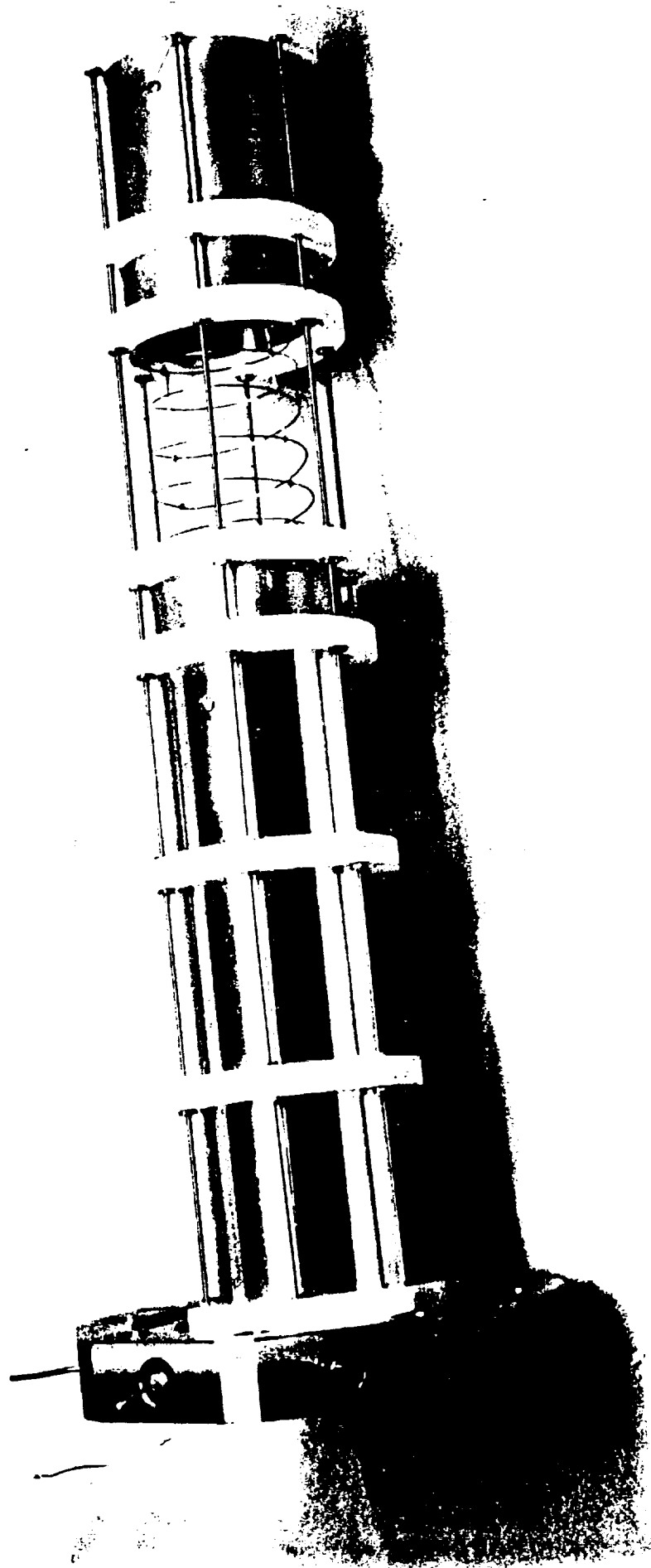

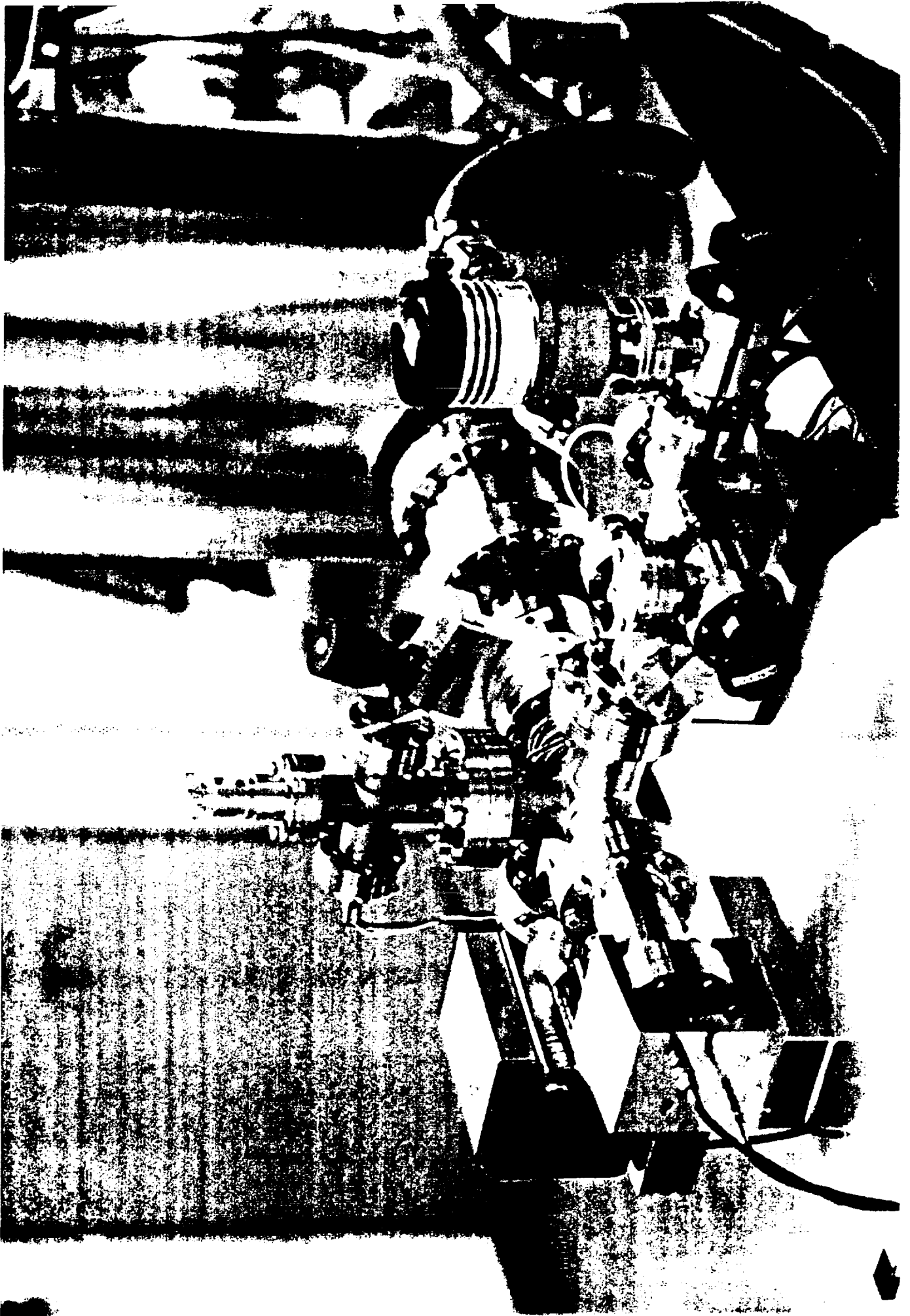

# Principles of the stored ion calorimeter

D.J. Wineland and H.G. Dehmelt

Department of Physics

University of Washington

JULY, 1996

## FIRST PENN STATE ELECTRON TRAP DATA

77K

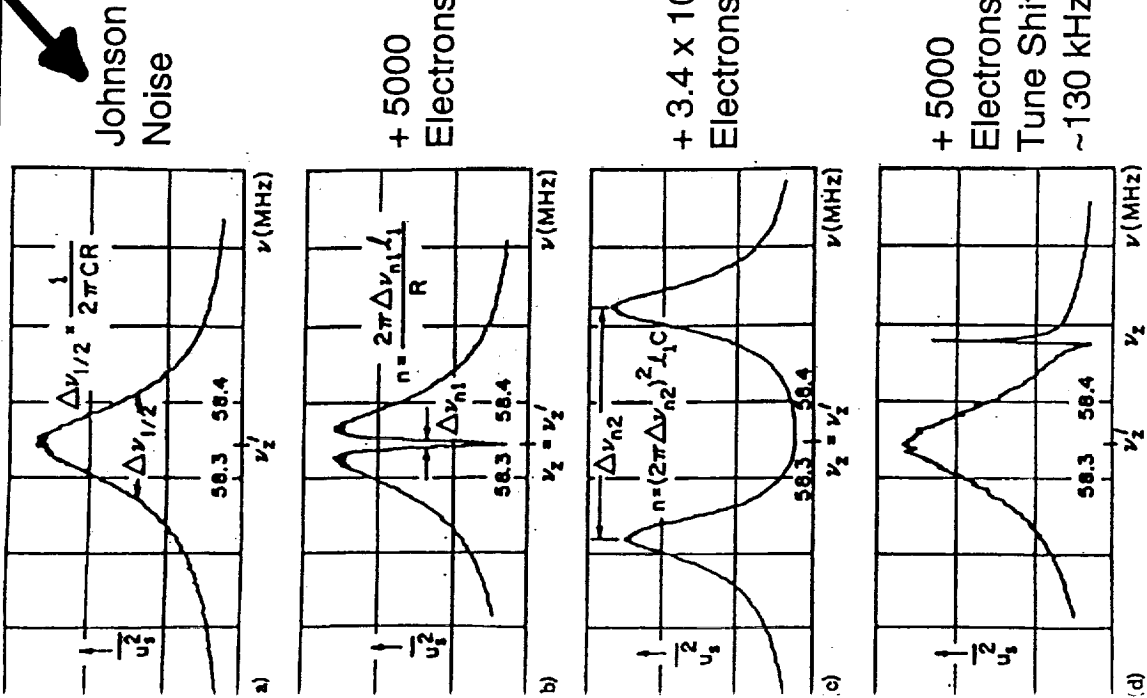

Noise spectra associated with electrons, Penning trap, and external circuitry.

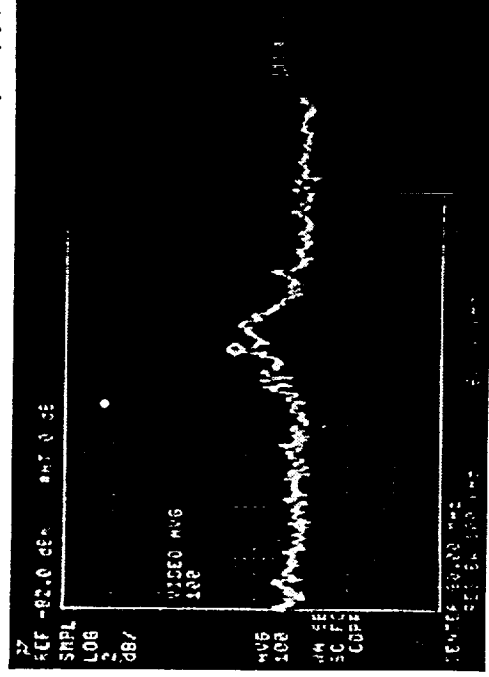

Figure 1 — Response of portable antiproton trap (electron) detector to Johnson noise in the resonant LRC circuit. The peak signal is 1.1 picowatt / 30 kHz at 30.5 MHz

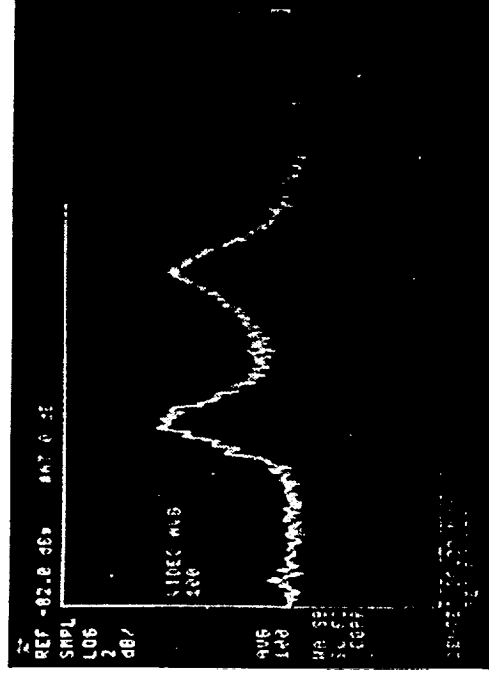
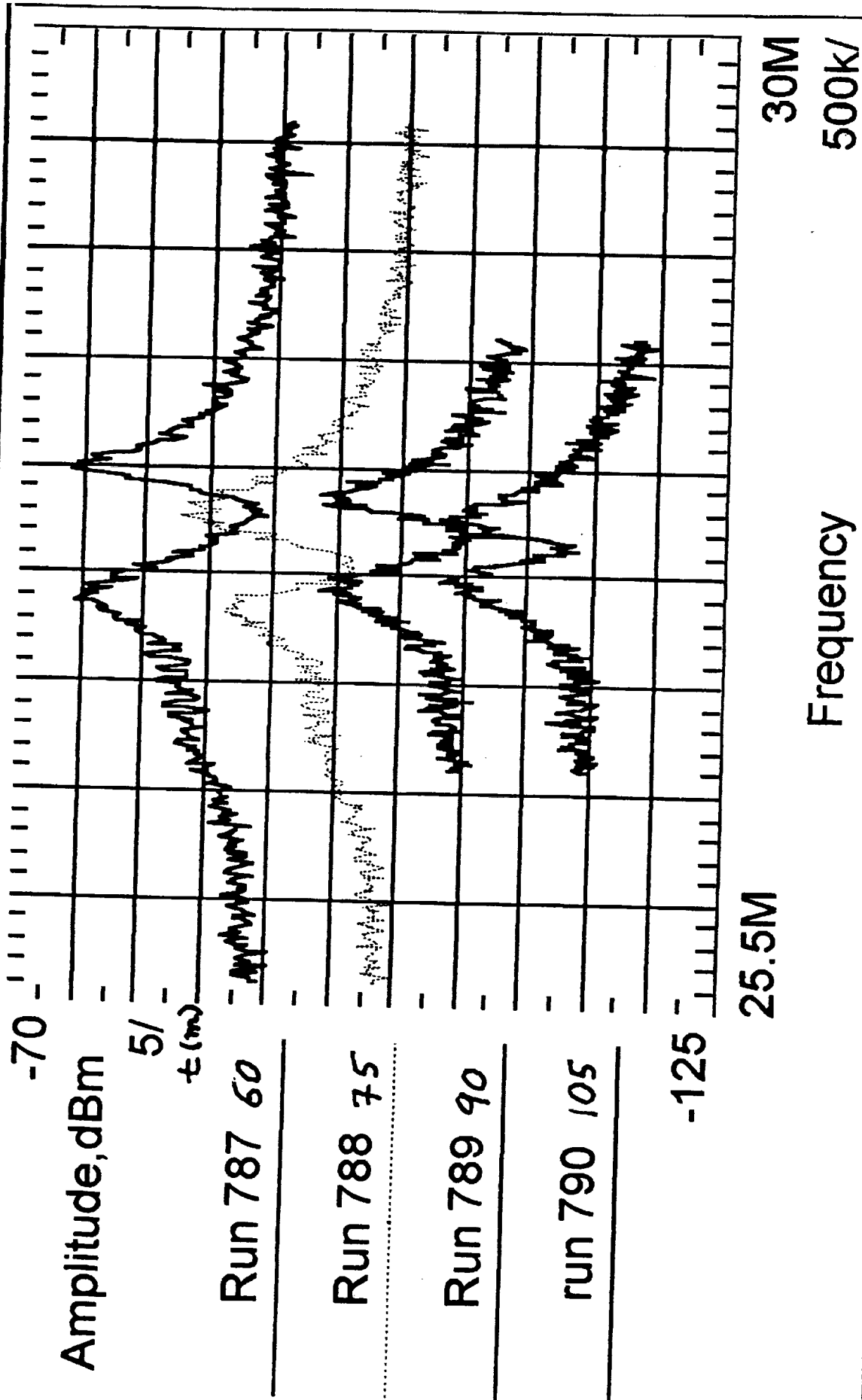
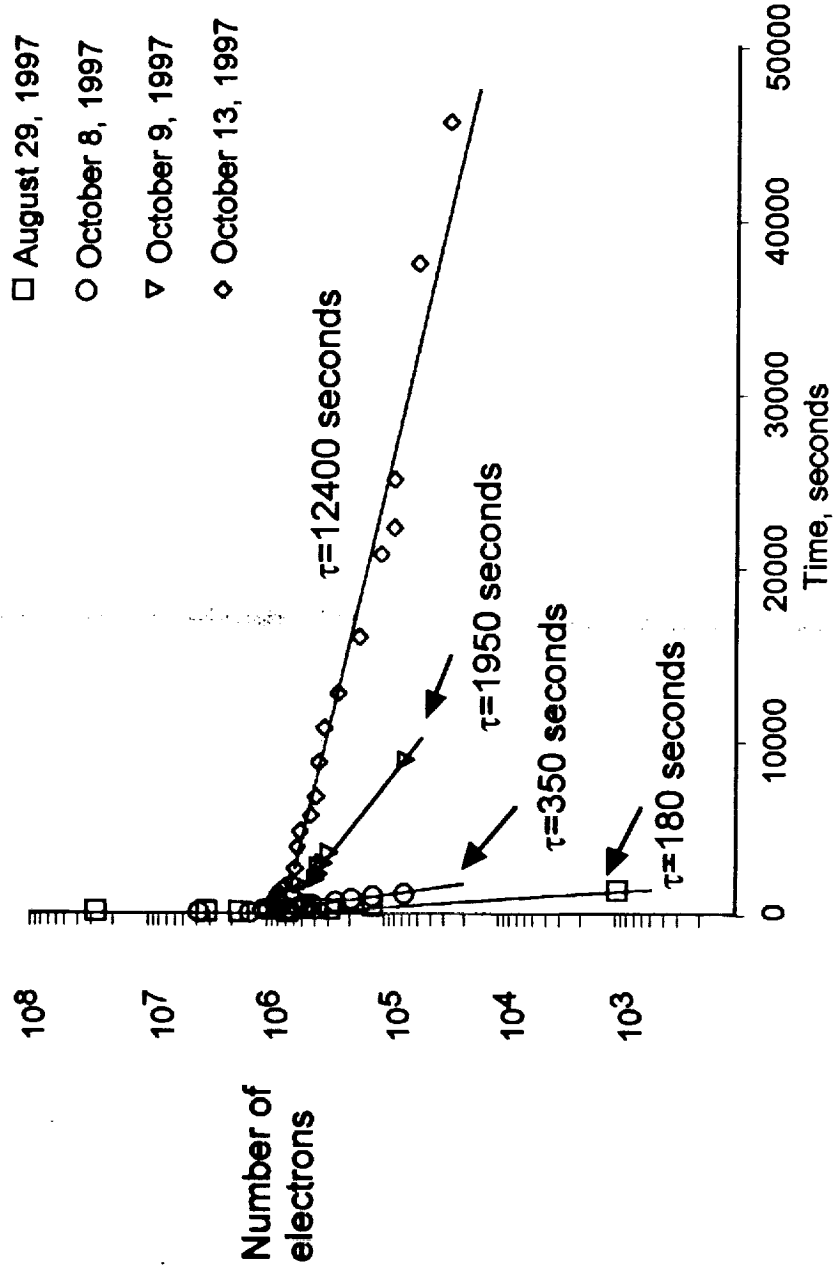

Figure 2 — Interference between signals from axial motion of electrons and Johnson noise. The 3 MHz splitting between the peaks at 28.6 and 31.6 MHz implies  $40 \times 10^6$  trapped electrons. The height of the peaks is 2.5 picowatts / 30 kHz.

e- signals, Dec. 5, 1997



# Electron lifetime in portable trap



# **ION TRAPPING AND EXTRACTION**

# +

## Extraction of H<sup>+</sup> ions

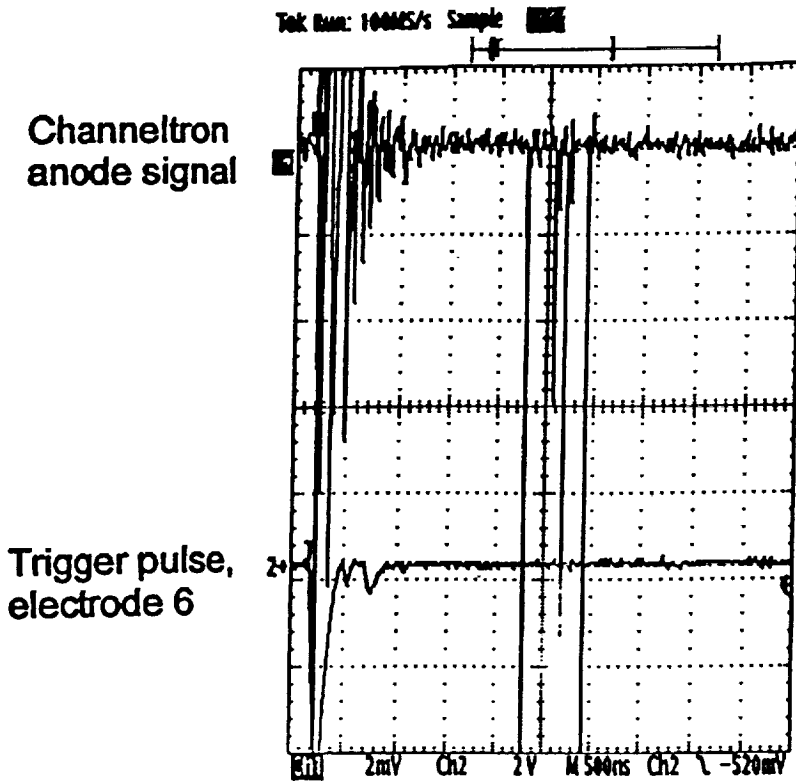

March 20, 1997 (4K)

11:24 – protons extracted

$V_{\text{Channeltron}} = -1800$  volts

$V_{\text{Bertan}} = 1225$  volts

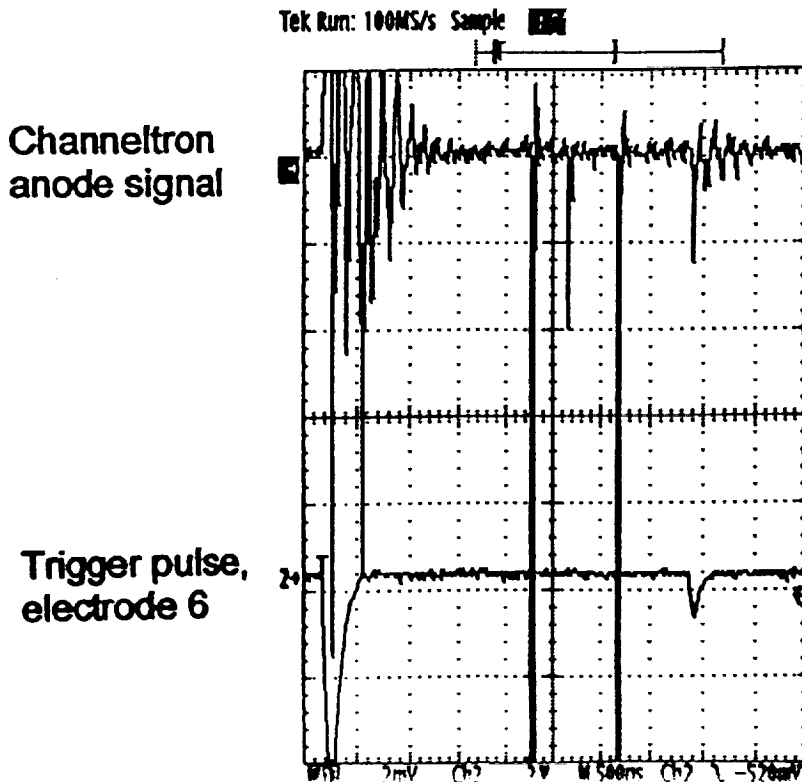

March 20, 1997

11:32 – protons extracted  
after  $10^{16}$  H<sub>2</sub> molecules  
injected into OVC

$V_{\text{Channeltron}} = -1800$  volts

$V_{\text{Bertan}} = 1225$  volts



# Time distribution of positive ions detected

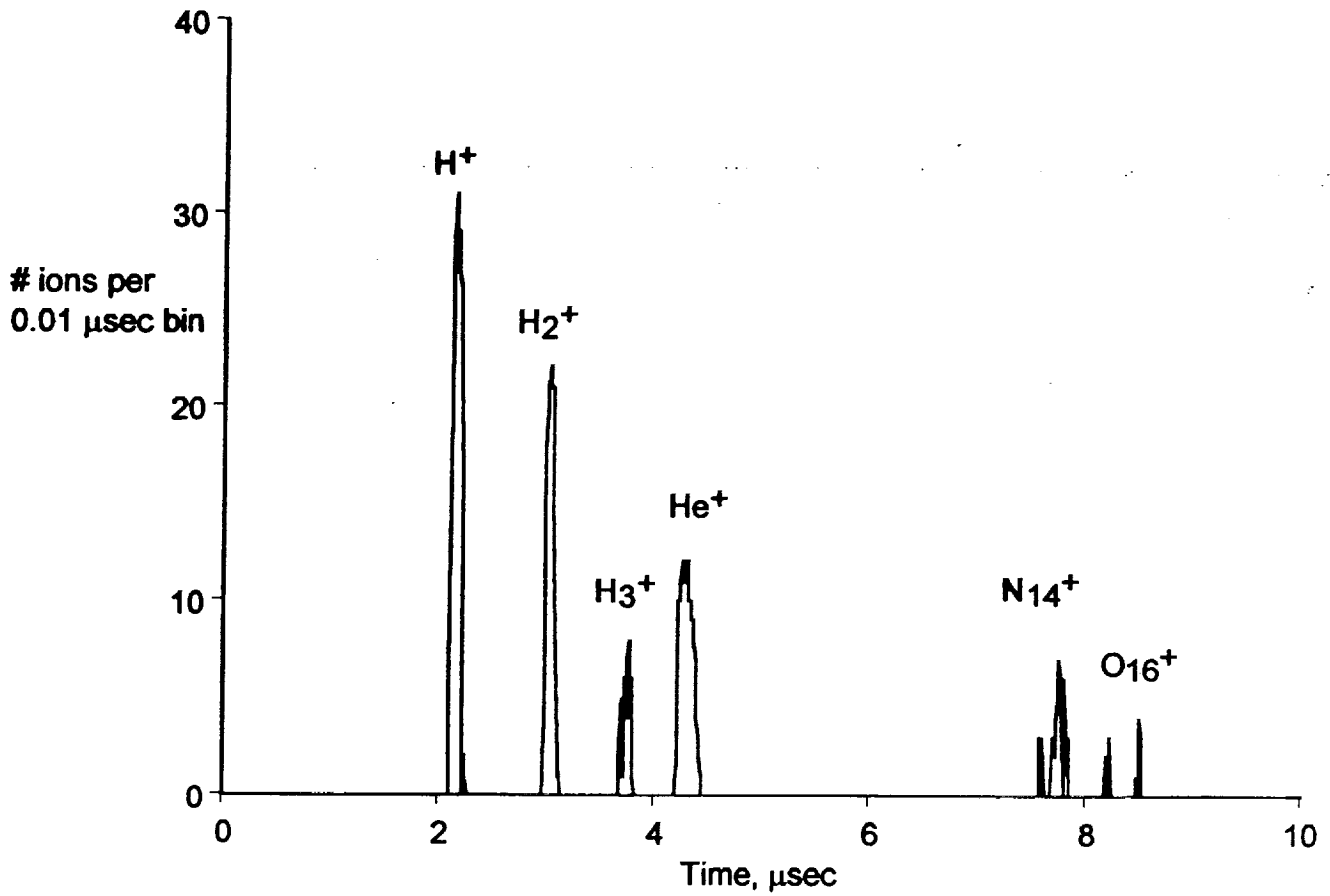

## Yields (4.5 k):

H <sup>+</sup>	281
H <sub>2</sub> <sup>+</sup>	196
H <sub>3</sub> <sup>+</sup>	58
He <sup>+</sup>	148
N <sub>14</sub> <sup>+</sup>	58
O <sub>16</sub> <sup>+</sup>	15

9/9/97  
RAL

# Ion Storage in Portable Trap (Extraction Technique)

December 1997 data

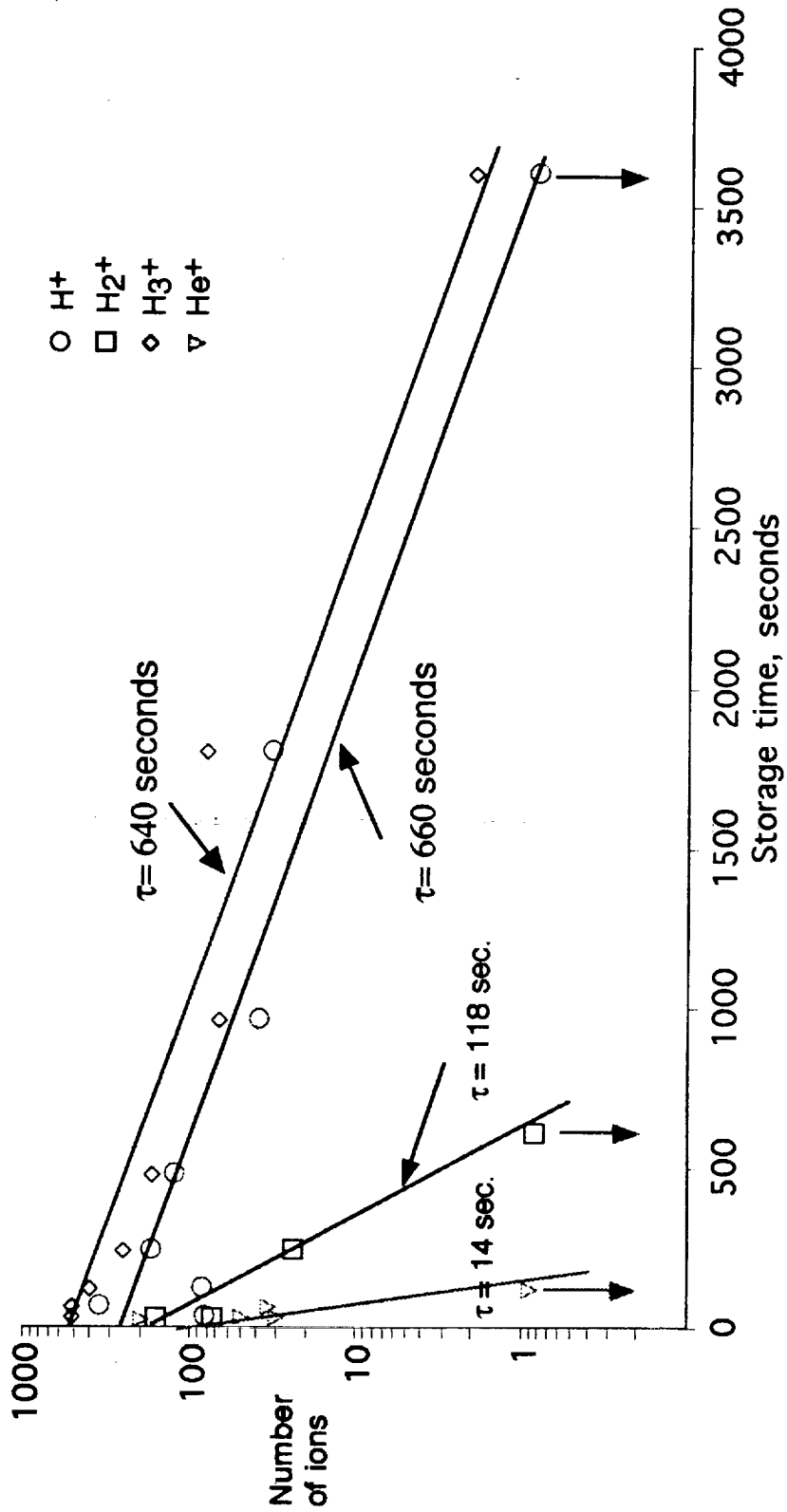

INNER VACUUM PRESSURE DETERMINED FROM PORTABLE  
TRAP POSITIVE ION LIFETIME MEASUREMENTS

1. Assuming that radial diffusion due to neutral gas scattering is responsible for lifetime, i.e.

$$\tau_{\text{diff}} = (1/\text{nov}) (\omega_c/\omega_z)^2,$$

we can scale ( $\tau \propto 1/\sqrt{m}$ ) from  $\tau_{1/2} = 660$  seconds for H<sup>+</sup> ions at 4.5 K to an electron lifetime of 28,300 seconds at 4.5 K. Using Malberg and Driscoll, PRL 44, 654, 1980 results for electrons, this lifetime corresponds to an inner trap neutral gas pressure of

$$P_{\text{it}} = \boxed{2.0 \times 10^{-10} \text{ torr. @ } 4.5 \text{ K.}}$$

consistent within a factor of two with the pressure deduced from independent electron measurements scaled to 4.5 K.

2. From Roth, "Vacuum Technology", we scale  $P_{\text{it}}$  to the outer beam region using

$$P_{\text{it}}/P_{\text{ob}} = (T_{\text{it}}/T_{\text{ob}})^{1/2}$$

With

$$T_{\text{ob}} = 300 \text{ K, } T_{\text{it}} = 4.5 \text{ K}$$

$$P_{\text{ob}} = 1.6 \times 10^{-9} \text{ torr,}$$

in good agreement with readings in the outer beam region.

# First Evidence for $H^-$ Ion Trapping

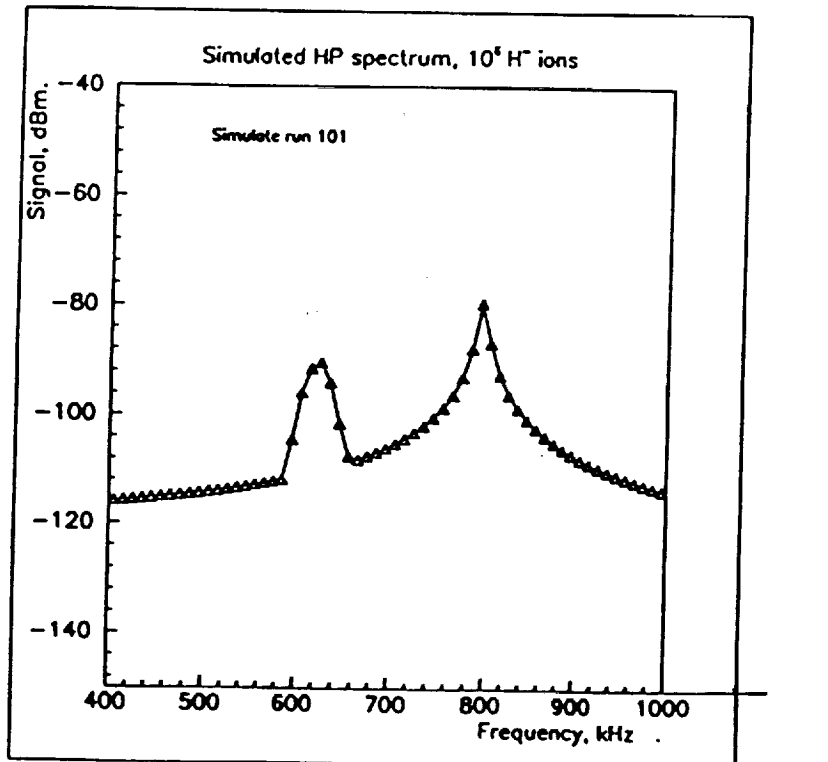
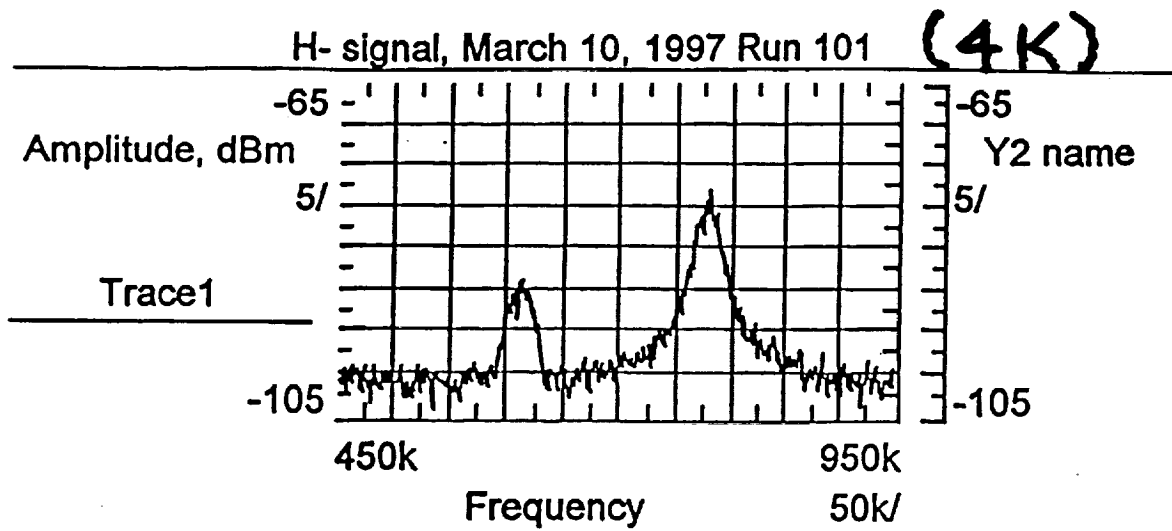

# H<sup>-</sup> Lifetime, Pressure

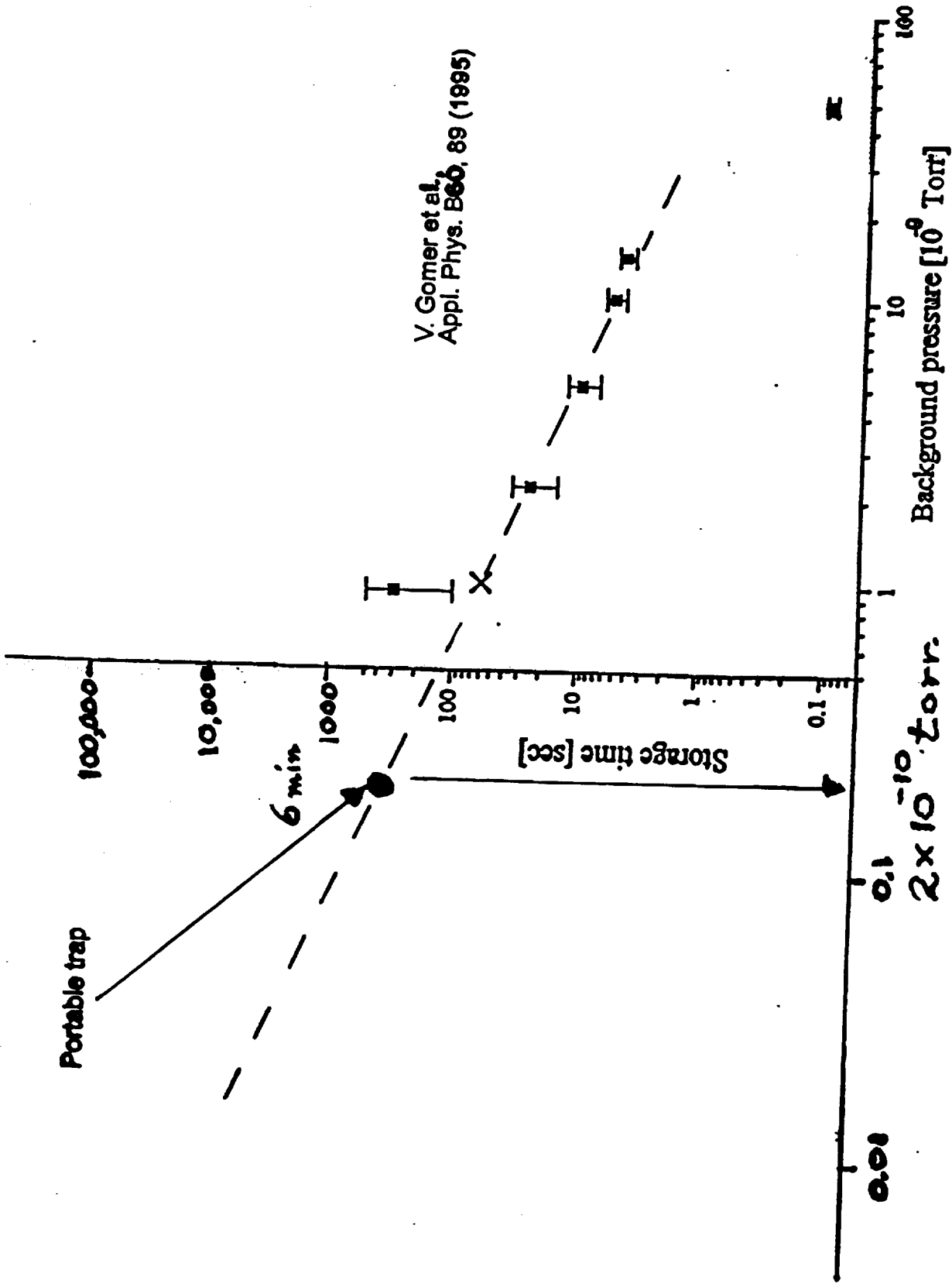
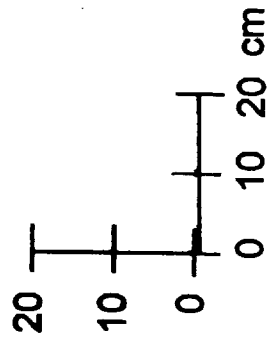
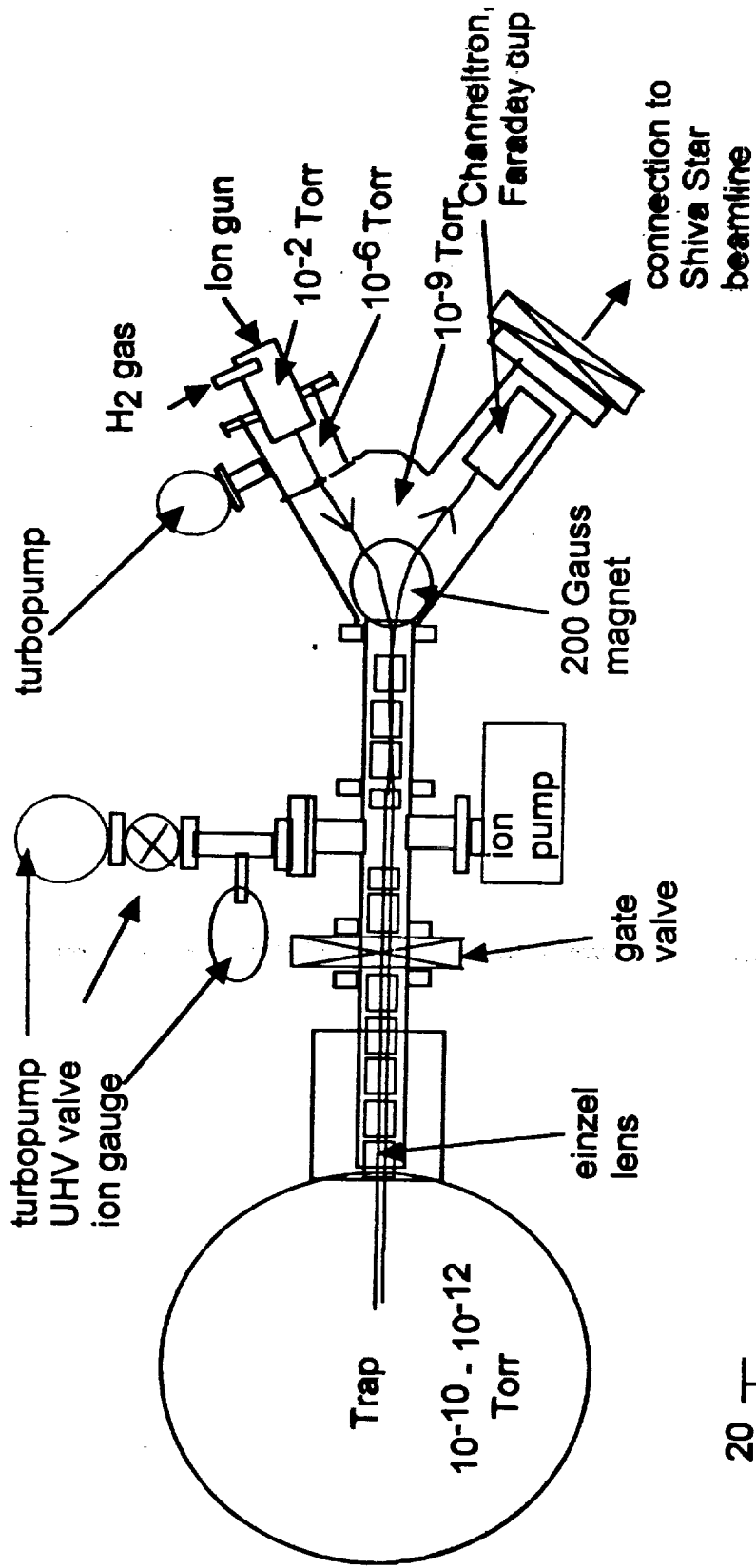

Fig. 10. Measured storage time for protons as a function of background pressure (squares: this work; cross: [13])

# Ion Injection/Extraction into/from Portable Trap



**FORMATION OF ATOMIC ANTIHYDROGEN**

**&**

**PRECISION TESTS OF CPT SYMMETRY  
BY COMPARISON WITH ATOMIC  
HYDROGEN**

# **ATHENA**

## **APPARATUS FOR HIGH PRECISION EXPERIMENTS WITH NEUTRAL ANTIMATTER (ANTIHYDROGEN APPARATUS)**

### **ATHENA COLLABORATION**

Bologna University & INFN, Bologna, Italy  
Brescia University & INFN, Brescia, Italy  
CERN, Geneva, Switzerland  
Escola Tecnica Federal do Ceara, Fortaleza, Brazil  
INFN Genova, Genova, Italy  
Los Alamos National Laboratory, Los Alamos, New Mexico, USA  
Napoli University & INFN, Napoli, Italy  
Pavia University & INFN, Pavia, Italy  
Pennsylvania State University, University Park, Pennsylvania, USA  
Pisa University & INFN, Pisa, Italy  
Rome University "La Sapienza" & INFN, Rome, Italy  
University College London, London, UK  
University of Aarhus, Aarhus, Denmark  
University of California at San Diego, La Jolla, California, USA  
University of Tokyo, Tokyo, Japan



# Antiproton Decelerator (AD)

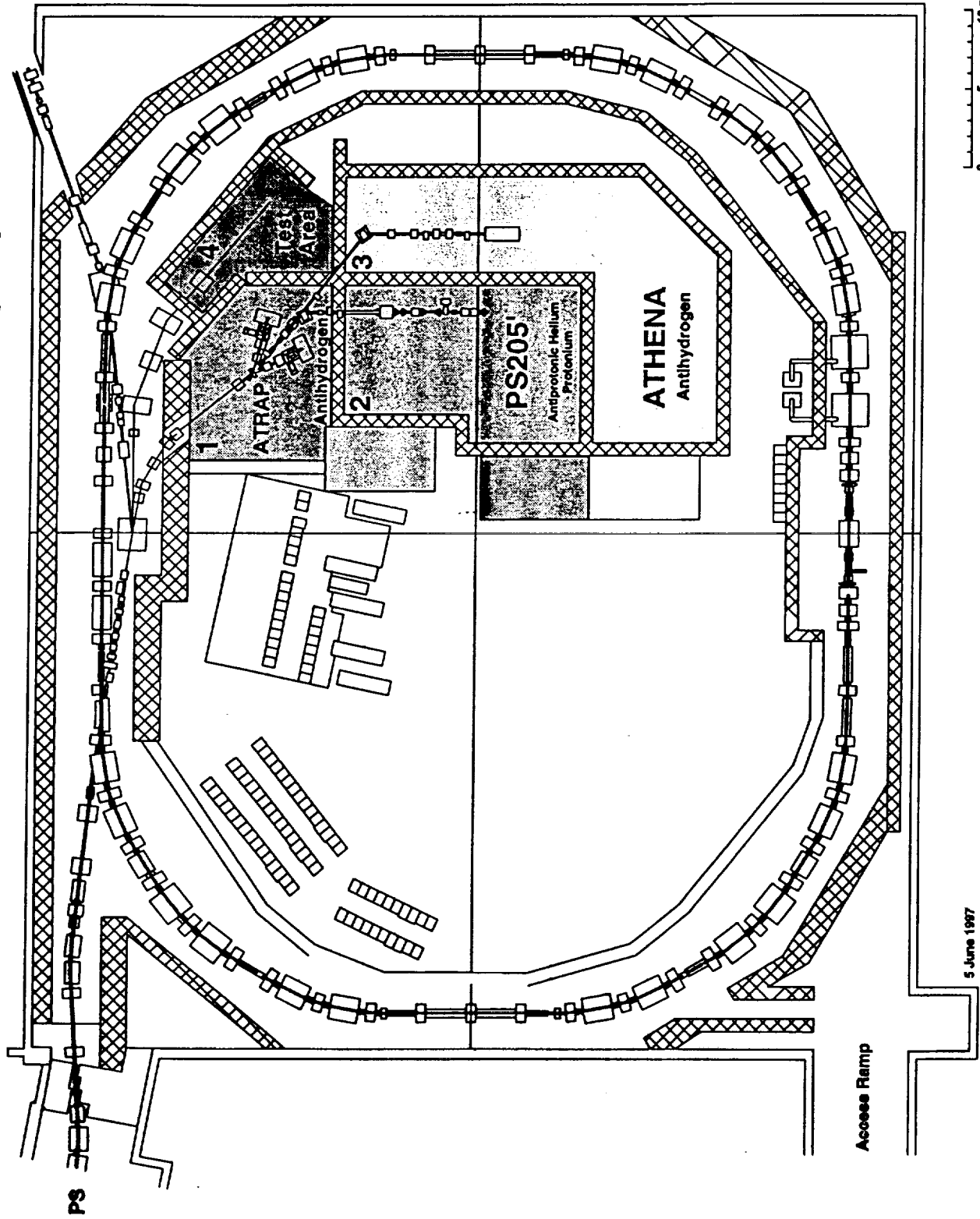

# CPT

- is a fundamental property of quantum field theories in flat space-time.
- Consequences include the predictions that particles and antiparticles have:
  - (a) equal (inertial) masses
  - (b) equal lifetimes
  - (c) equal and opposite electric charge/magnetic moment

# TESTS

Charge-to-mass ratio of  $\bar{p}$  and  $p$ : 1 part in  $10^9$

G. Gabrielse, *et al.*, LEAR Experiment PS196, i. e. PRL 74 (1995) 3544

Magnetic moment of  $e^-$  and  $e^+$ : 1 part in  $10^{12}$

R. S. van Dyck, Jr. *et al.*, PRL 59 (1987) 26

Mass difference of  $K_0$  and  $\bar{K}_0$ : 5 parts in  $10^{18}$

R. Carosi *et al.*, Phys. Lett. B 237 (1990) 303

---

Anti-Rydberg:  $R_{\bar{H}} = \frac{m_{e^+} m_{\bar{p}}}{m_{e^+} + m_{\bar{p}}} \frac{e_{e^+}^2 e_{\bar{p}}^2}{8\epsilon_0 c h^3}$  1 part in  $10^{12}?$

## The 1S-->2S Transition and CPT

$$R_{\bar{H}} = \frac{m_{\bar{p}}m_e}{m_{\bar{p}} + m_e} \frac{e_{\bar{p}}^2 e_e^2}{8\epsilon_0^2 c h^3}$$

A difference of  $R(H)/R(\bar{H})$  from unity would signal CPT violation mixed among masses and charges. In terms of measurable we write:

$$\frac{R_{\bar{H}}}{R_H} = \frac{(m_p/m_e)(\rho_{\bar{p}e}/\rho_{\bar{p}\bar{p}})}{\rho_{\bar{p}e}(e_{\bar{e}}/e) + \rho_{\bar{e}e}(e_{\bar{p}}/e)} \left(\frac{e_{\bar{p}}}{e}\right)^3 \left(\frac{e_{\bar{e}}}{e}\right)^3$$

With ultimate precisions of  $10^{-11}$  for the positron/electron charge ratio (positronium), as well as cyclotron frequency ratios, and

$$R(H)/R(\bar{H}) = 10^{-15}$$

then  $e(\text{antiproton})/e(\text{electron}) = 10^{-11} > 10^{-11}$

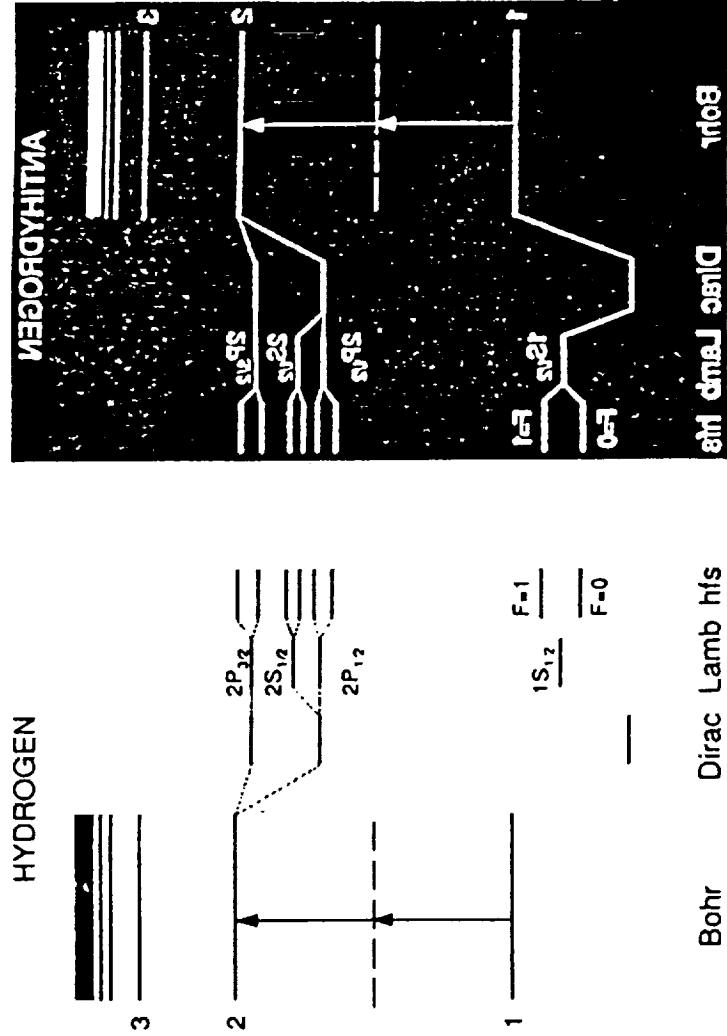
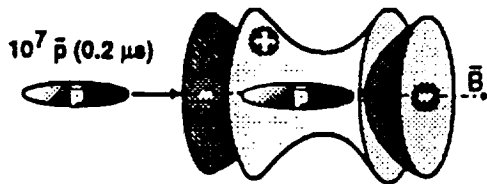
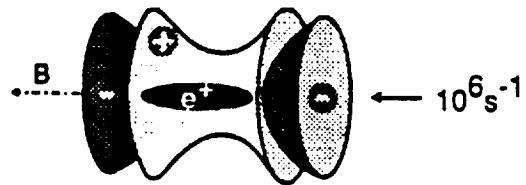

Fig. 1. Energy levels of hydrogen and antihydrogen, showing: the principal structure from Bohr's (nonrelativistic) quantum mechanics; the relativistic corrections from Dirac's theory which splits apart states of different angular momenta; the Lamb shift of quantum field theory which raises the energies of S-states; the hyperfine splitting (hfs) which arises from the magnetic interaction between the (anti)proton and the electron (positron); and the 1S-2S two-photon transition.

**1 Antiproton Capture in Penning Trap**



**2 Positron Accumulation from Na-22 source (Buffer Gas Method)**



**3 Positron-Antiproton Recombination @ 0.5 K**

**Radiative Recombination (with Laser stimulation?)**

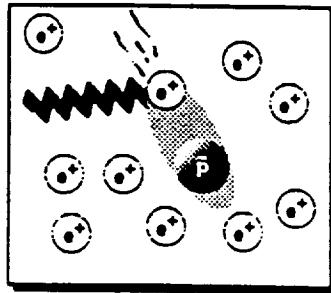

to be explored

**Positronium-Collisions**

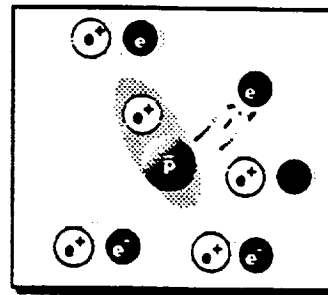

to be explored

or

**4 Antihydrogen Storage and Cooling in Magnetic Bottle Wall depth ~ 0.5 K**

**5 Antihydrogen Detection**

- Annihilation products: Si Pad Detectors
- 511 keV Gammas: Csl crystals + Photodiodes

**6 Lamb Shift - type experiments and 2-Photon Laser Spectroscopy:  $\Delta E$  (1s-2s)**

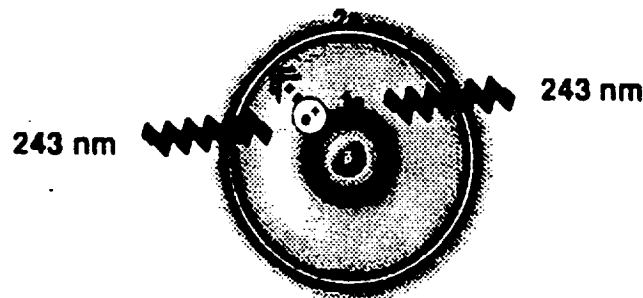

Comparison H :  $\bar{H}$  with precision  $10^{-12} \dots 10^{-16}$

CLAUDIO L. CESAR (THESIS MIT 1996)

$\Delta\nu = 1 \text{ kHz} \Rightarrow 1 \text{ PART IN } 10^{12}$   
(DOMINATED BY LASER LINEWIDTH)

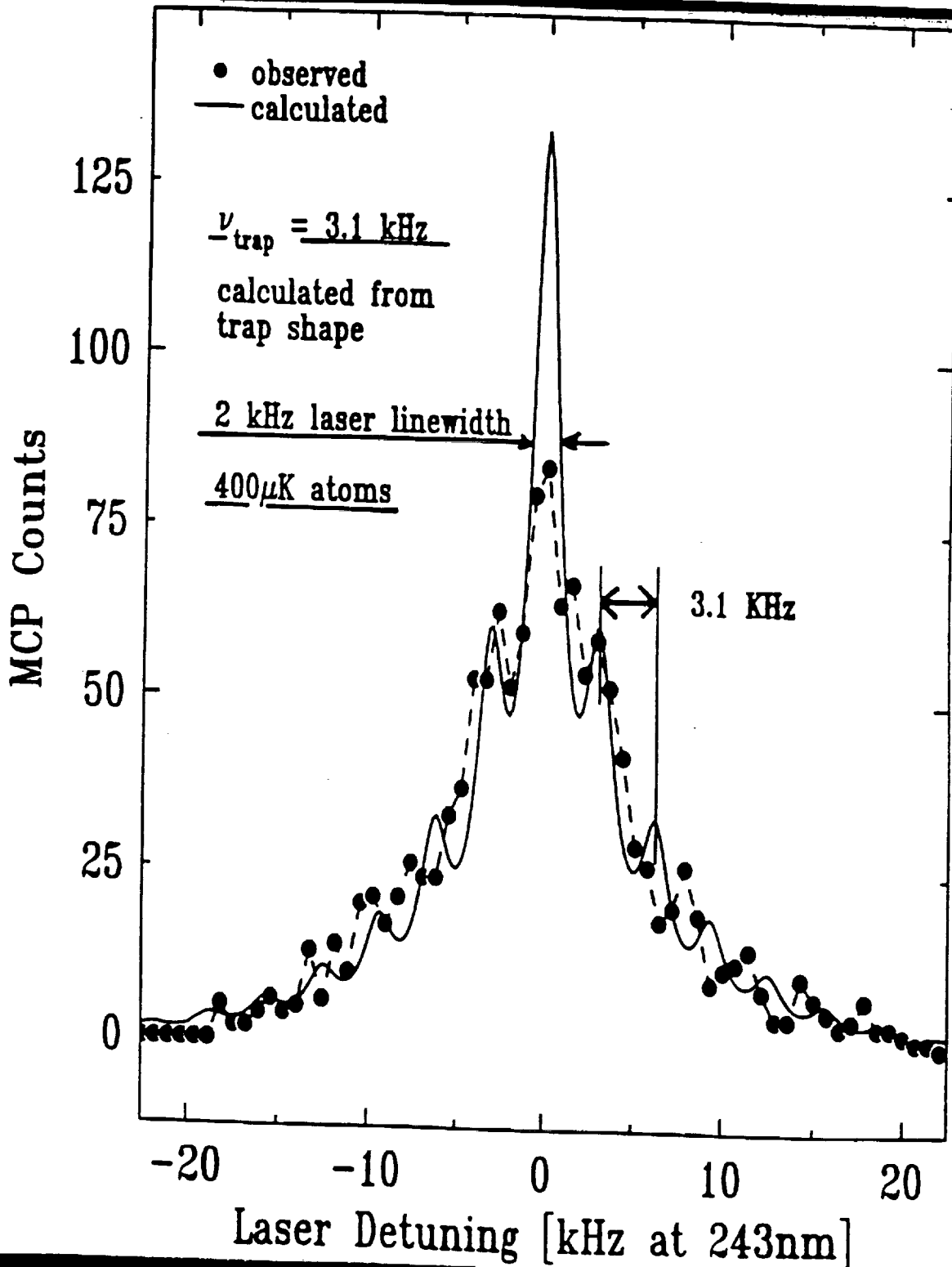

# Recombination of Antiprotons and Positrons

Spontaneous Recombination  
(Overlapping Antiproton-Positron Plasmas)

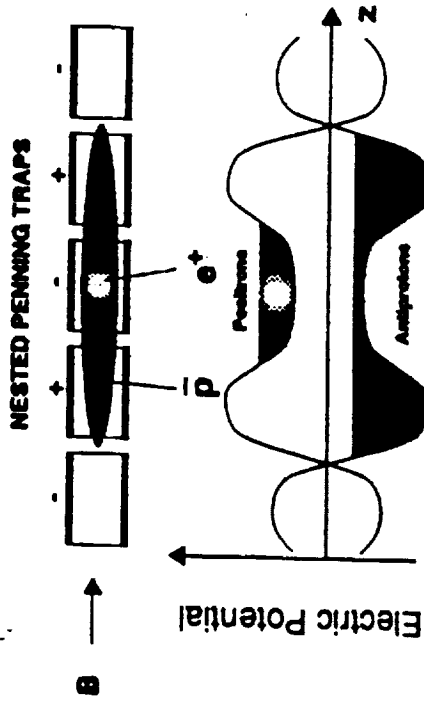

Positronium-Antiproton Recombination  
(Positron Beam Conversion to  $P_s$ )

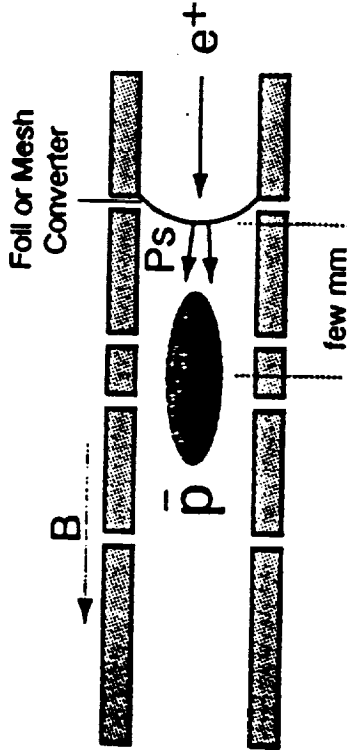

# ANTIHYDROGEN PRODUCTION SCHEMES

## I. (Stimulated) Radiative Recombination

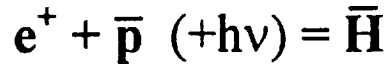

Recombination coefficient:

$$\alpha(\nu) = \langle \sigma(\nu) \nu \rangle = \begin{array}{l} 3.2 \times 10^{-13} \text{ cm}^3 \text{ s}^{-1} \text{ (1eV)} \\ 7.1 \times 10^{-12} \text{ cm}^3 \text{ s}^{-1} \text{ (10 meV)} \\ 0.9 \times 10^{-10} \text{ cm}^3 \text{ s}^{-1} \text{ (0.1 meV)} \end{array}$$

Agrees well with Measurements in Beam for similar relative velocities in the center-of-mass reference frame (A. Wolf *et al.* ; F. B. Yousif *et al.*; U. Schramm *et al.*)

for the ATHENA values  $N_{e^+} = 10^8$ ,  $N_{\bar{p}} = 10^7$ :

$$R(\nu) = a(\nu) \int n_e(\mathbf{r}) n_{\bar{p}}(\mathbf{r}) d^3\mathbf{r} =$$

$$300 \text{ s}^{-1} \text{ (1eV)}, 7000 \text{ s}^{-1} \text{ (10meV)}, 90,000 \text{ s}^{-1} \text{ (0.1meV)}$$

Enhancement by Laser Stimulation:

$$G_{nl}(E_{cm}) = \frac{R_{nl}^{ind}(E_{cm})}{R_{nl}^{spon}(E_{cm})} \approx 10^2$$

TSR Heidelberg:  $G = 70 \pm 2$  with 20MW/cm<sub>2</sub> pulsed Laser



### III. Laser Enhanced Positronium Collisions with Antiprotons

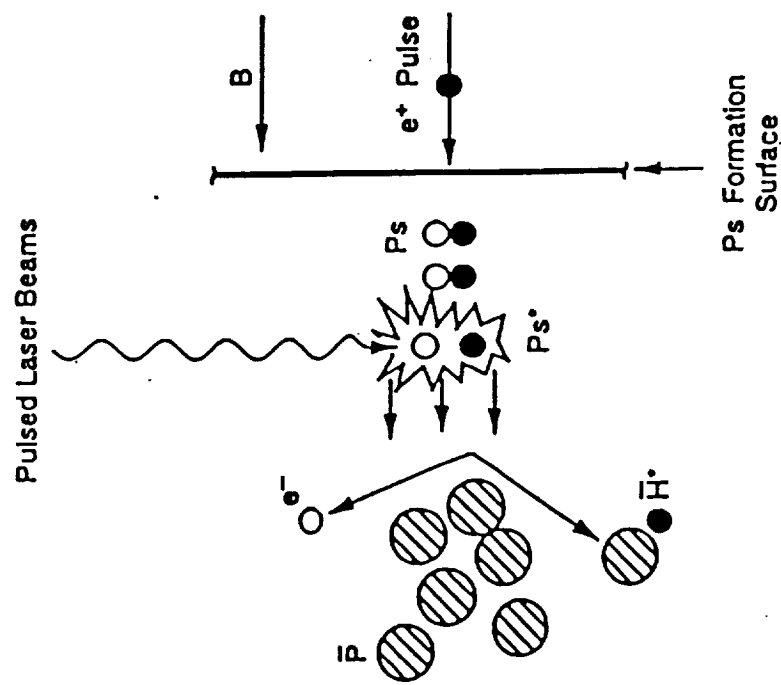
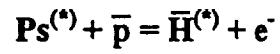

Fig. 15. Laser-enhanced antihydrogen formation on excited positronium [163]. The Ps atoms, formed at the trap walls in ground state, are excited by a laser pulse and form an excited  $\bar{\text{H}}$  atom on an antiproton stored in the Penning trap

### III. Positronium Reaction



Charge conjugate reaction tested in laboratory:

J. P. Merrison *et al.*; sub. to Phys. Rev. Lett.

$$R = 8.1 \pm 3.1 \times 10^{-4} s^{-1} \Rightarrow 10 \bar{H}/10^{10} e^{+}$$

(Ground state reaction rate is low,  $n^4$  enhancement)

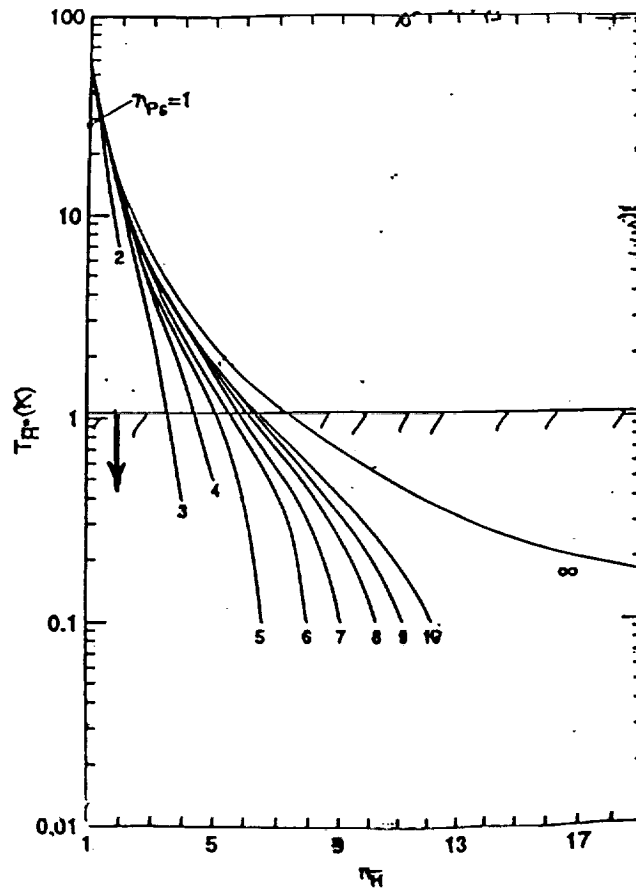
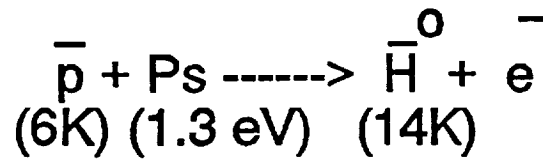

# **ATHENA**

## **APPARATUS FOR HIGH PRECISION EXPERIMENTS WITH NEUTRAL ANTIMATTER (ANTIHYDROGEN APPARATUS)**

### **Phase 1**

**Study formation rates of 1 K antihydrogen atoms and their capture in a magnetic gradient trap by observing annihilation on surrounding walls with CsI crystal and Si pad detectors.**

### **Phase 2**

**Laser cool stored antihydrogen atoms , followed by adiabatic cooling, to the millik regime and investigate Doppler-free two photon spectroscopy.**

# *ATHENA Central Trap Arrangement*

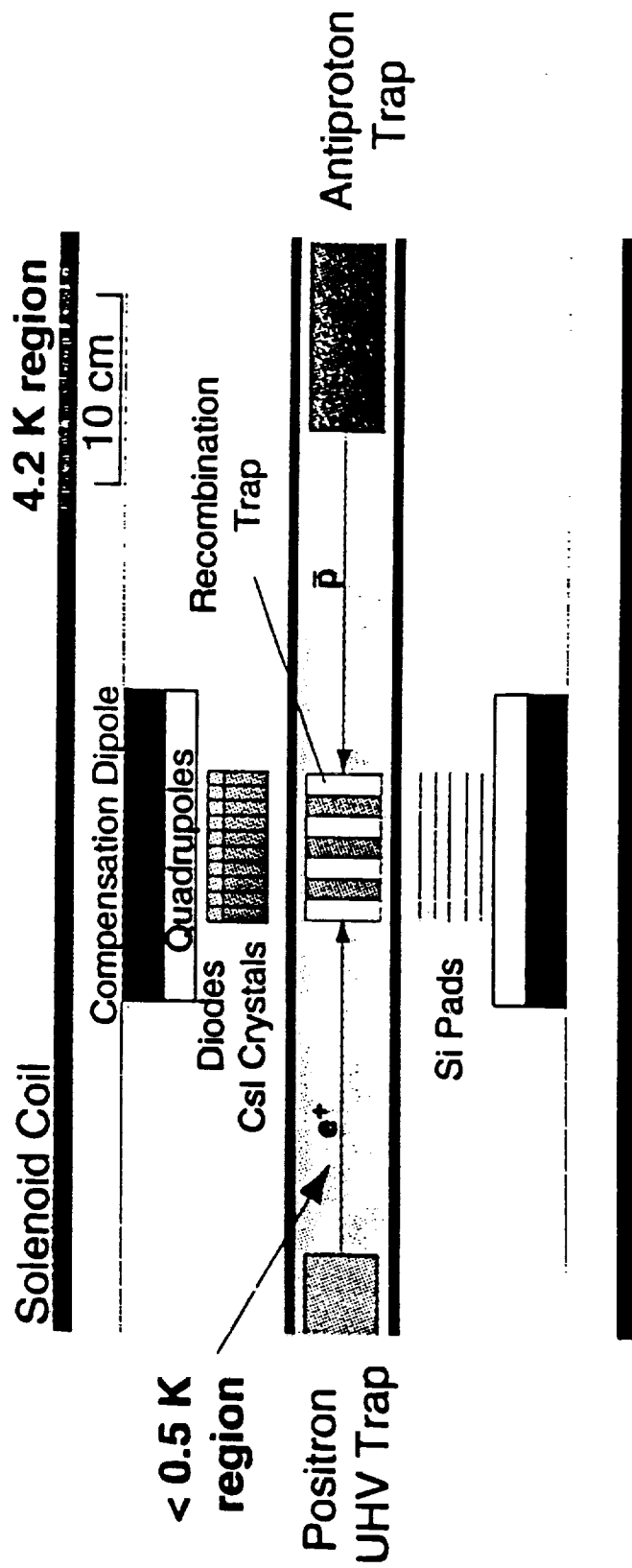

# LASER SPECTROSCOPY OF HYDROGEN AND ANTIHYDROGEN

T.W.Haensch and C. Zimmerman  
Hyperfine Interactions, 76, 47 (1993)

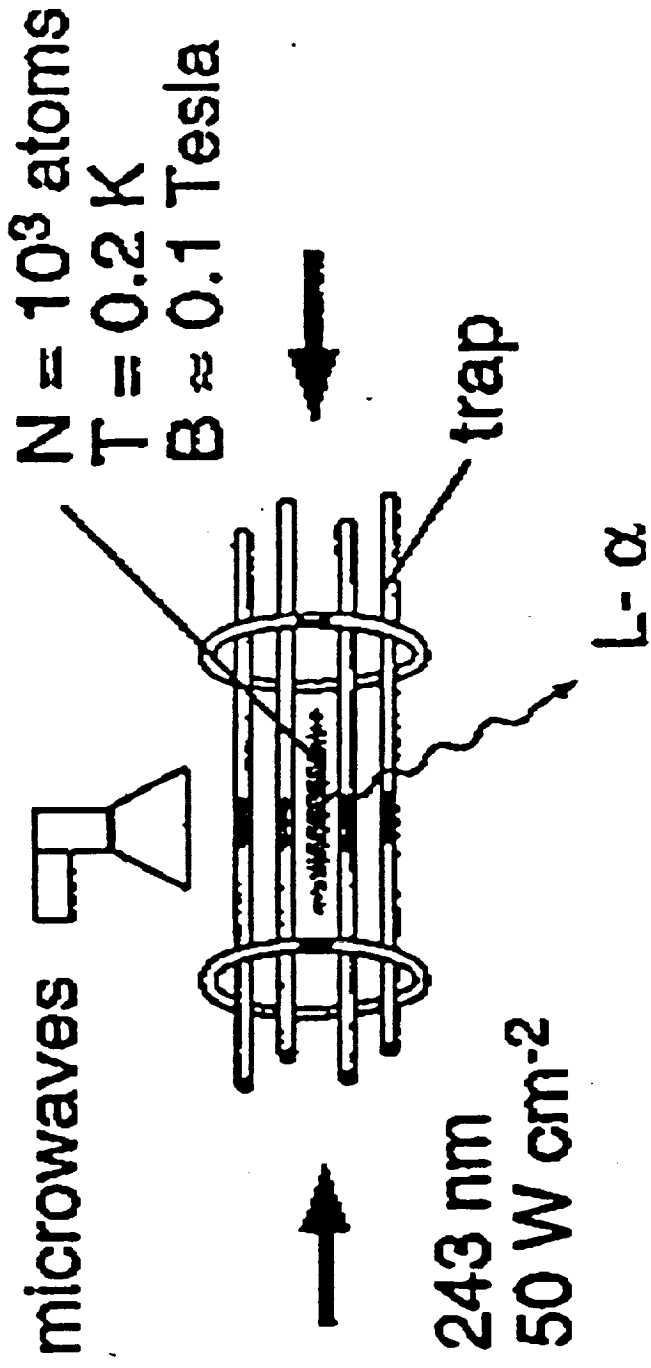

Fig. 5. Scenario for two-photon spectroscopy of trapped antihydrogen.

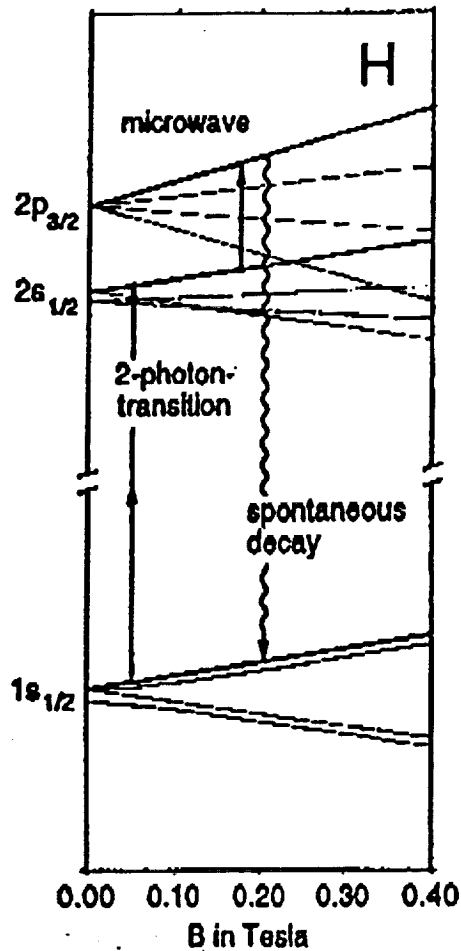

Fig. 4. Scheme of a closed cycle of two-photon excitation and resonance fluorescence for hydrogen atoms in a magnetic trap. Spin flips are avoided with the help of a weak microwave quenching field, so that all states remain low-field seeking.

3  
 1)  $10^3 \bar{H}$  atoms  $\rightarrow$   $\sim 600$  detected L-alphas

2)  $1S \rightarrow 2S$  line center determination limited by Zeeman broadening and statistics:

$$\Delta f/f = \frac{4}{1.23 \times 10^4} \times \sqrt{600} \sim 10^{-12}$$

# TESTING THE WEAK EQUIVALENCE PRINCIPLE OF GRAVITY FOR ANTIMATTER

The Equivalence Principle is a cornerstone of Einstein's Theory of General Relativity. The Weak Equivalence Principle (WEP) applies to mechanical quantities, i.e. are Newton's inertial and gravitational masses the same?

Tests of WEP began with Galileo, proceeded with the work of Eötvös, and presently we know that different macroscopic bodies fall in the gravitational field with the same acceleration to an accuracy of one part in one hundred billion.

## **WHY TEST ANTIMATTER?**

**Modern theories of gravity which conserve CPT symmetry that attempt to unify gravity with the other forces predict that in principle antimatter can fall differently than normal matter in the Earth's field. Some super-gravity theories predict that antimatter will fall faster than matter.**

**The gravitational behavior of antimatter has never been successfully tested experimentally.**



# Antimatter Gravity-is it Different?

THE NEW YORK TIMES INTERNATIONAL FRIDAY, JANUARY 5, 1996

## Physicists Succeed in Creating Atoms Out of Antimatter

By MALCOLM W. BROWNE

"Everyone makes shrewd guesses about the probable behavior of antihydrogen and other antiatoms," Dr. Eades said, "and we don't really expect a big surprise — that an atom of antimatter would fall up instead of down, for instance. But there may be subtle differences of great importance. For instance, an atom and an antiatom might fall at slightly different speeds toward a gravitating object like the sun. Our orbit around the sun is elliptical, so the sun's gravitational pull on the earth varies slightly over a year, and by observing its effect on an antihydrogen atom, we might learn interesting things."

In principle, scientists believe that atoms larger than antihydrogen — the simplest possible atomic form of antimatter — might be created. But each increase in the size and complexity of an atom complicates the assembly problem. Antihelium, the most complicated atom after hydrogen, would have a nucleus of two antiprotons and two antineutrons, with two orbiting antielectrons.

CERN PHYSICIST

"We're especially interested in hydrogen and antihydrogen," Dr. Eades said, "not only because of their structural simplicity, but because 90 percent of the mass of the universe is hydrogen. Even slight differences in the properties of hydrogen and antihydrogen could help explain why the universe, as we know it, consists entirely of matter rather than antimatter."

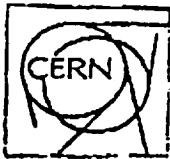

ORGANISATION EUROPÉENNE POUR LA RECHERCHE NUCLÉAIRE  
EUROPEAN ORGANIZATION FOR NUCLEAR RESEARCH

Laboratoire Européen pour la Physique des Particules  
European Laboratory for Particle Physics

Adresse postale / Mailing address:

Johs Ellis

CERN/TH  
CH - 1211 GENEVA 23  
Switzerland

Téléphone / Telephone:

Direct +41 22 767 4142  
General +41 22 767 6111  
Telex / Telex 41 80 80 CER CH  
Electronic mail john.ellis@cern.ch

Geneva, 17 April 1997

The production of antihydrogen and the comparison of its energy levels with hydrogen to very high precision addresses two fundamental issues of particle physics:

1) CPT invariance is a fundamental property of local quantum field theories. Any deviation from exact equality of matter and antimatter - at whatever level - would have profound implications. The comparison of antihydrogen with hydrogen offers the possibility of making far more stringent tests of CPT than those attained so far in other experiments, apart from the neutral kaon system, whose nature is rather different. Even though the final sensitivity will be hard to reach, already the sensitivities which can be reached in the first stage of these experiments should surpass considerably the other particle-antiparticle tests listed in the Review of Particle Properties. As a result of earlier work by Hawking, Page and Wald, the possibility of CPT violation associated with quantum-gravity effects has recently attracted growing interest, and is one of my own personal research interests [see for example the paper Phys. Rev. D53 (1996) 3846 by Mavromatos, Nanopoulos, Lopez and myself, and the review hep-ph/9607434]. Although it is difficult to estimate the order of magnitude of any possible CPT-violating effect, which may well lie beyond experimental reach, this line of research demonstrates that quantized space-time may result in observable CPT-violating effects. It is therefore of utmost importance to devise new experiments to push the present limits to higher precision, in as many different physical systems as possible. Antihydrogen promises to be an extremely sensitive tool in this endeavour.

2) The gravitational force between matter and antimatter has never been measured, apart possibly from an experiment by Fairbanks and Witteborn. As was pointed out some time ago by Scherk, followed by many other authors, in certain models of supergravity there appear additional vector interactions associated with the gravitational field, which would change sign with the baryon number. Therefore, antihydrogen might experience a different gravitational redshift from hydrogen. An experimental test of the equivalence principle with a precision of  $10^{-3}$  or better, as seems to be within reach, would give valuable constraints on such a possible manifestation of such extended gravity theories.

Yours Sincerely,

**Table 1: Predictions of difference between proton, antiproton weights**

Phenomenon	Predicted violation of WEP
Structure of space-time [7]	200 %
Deviation from $1/r^2$ dependence [2]	15 %
Vector, scalar gravity [6]	$10^{-6}$

[2] M.M. Nieto, T. Goldman, J.D. Anderson, E.L. Lau, and J. Perez-Mercader, "Theoretical motivation for gravitation experiments on ultra-low energy antiprotons and antihydrogen", Proceedings of the Third Biennial Conference on Low Energy Antiproton Physics, Bled, Slovenia, G. Kernel, P. Krizan, M. Mikuz editors, World Scientific, 606, 1995.

[6] E.G. Adelberger, B.R. Heckel, C.W. Stubbs and Y. Su, Phys. Rev. Letters 66, 850, 1991.

[7] G. Chardin, Nuclear Physics A 558, 477-496, (1993).

# Ballistic Measurement of Antiprotons

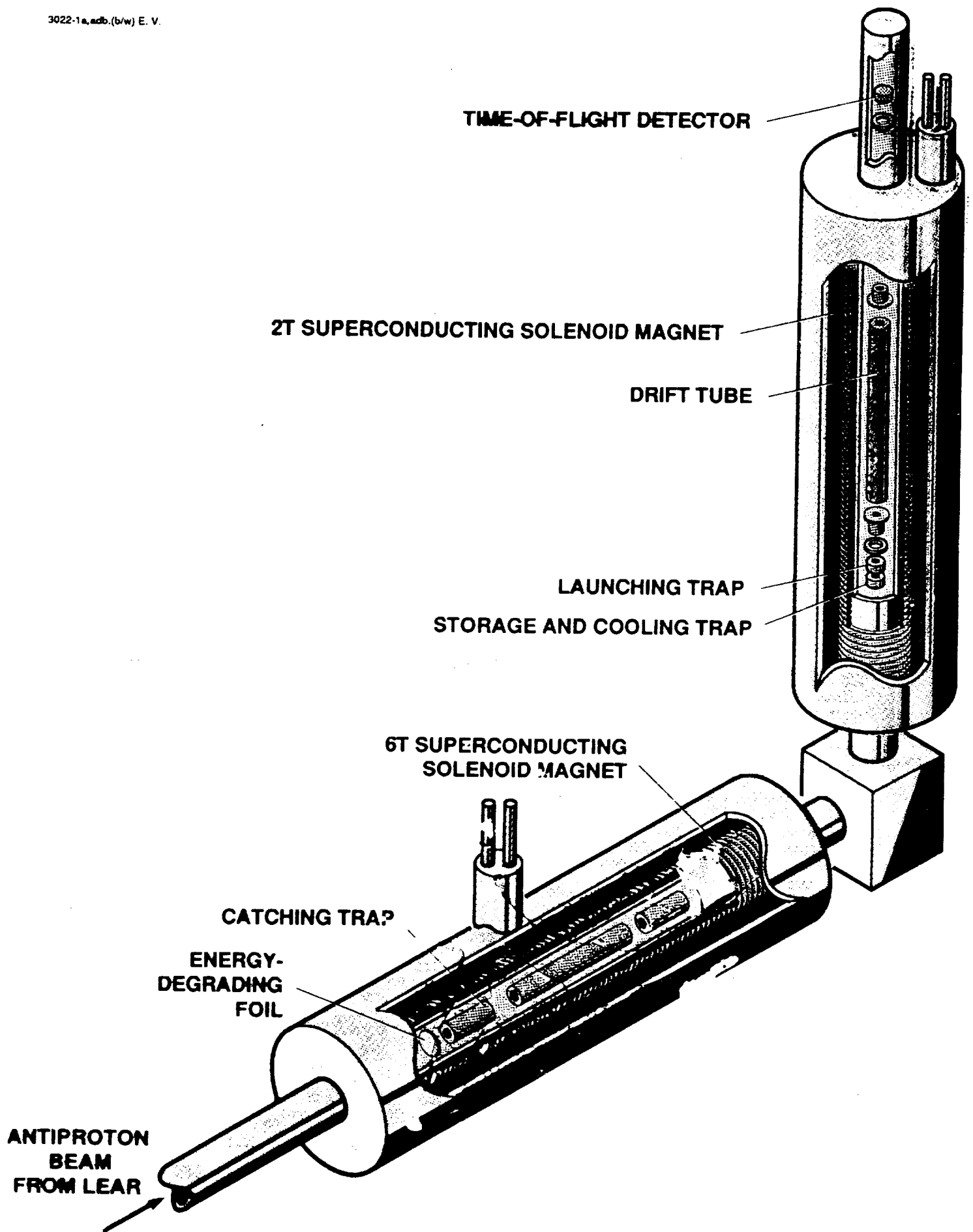

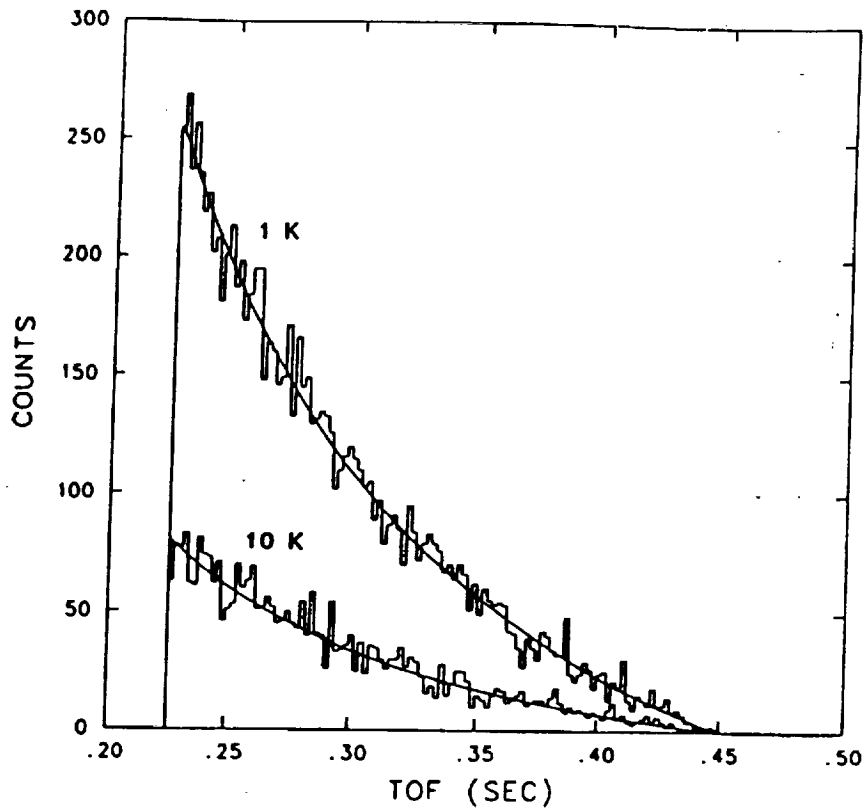

Fig. 3. Monte Carlo results for the late-time portion of the TOF spectrum for upward launch using a MB distribution of initial velocities for the temperatures indicated. The curves are fits to the spectra. Note cutoff (see text also).

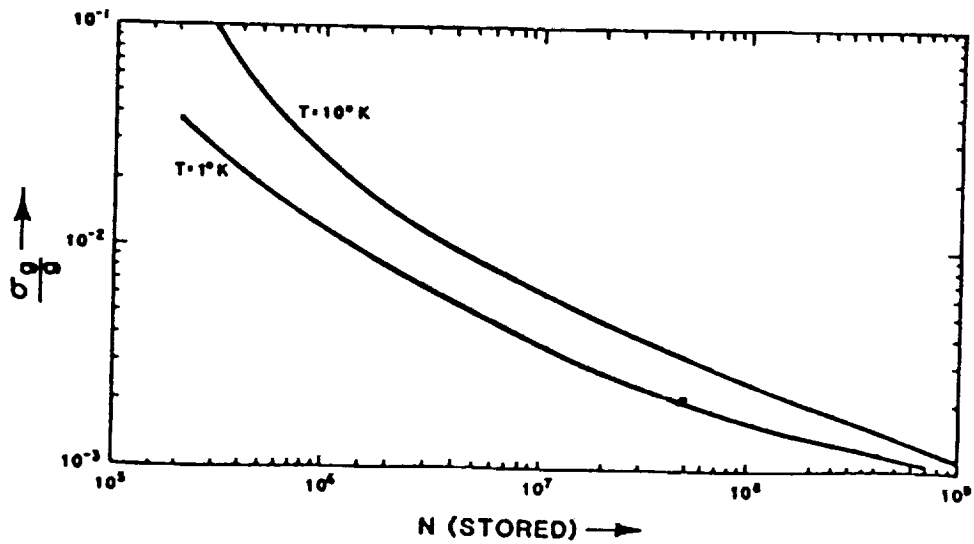

Fig. 4. Relative error in gravitational acceleration versus total number of particles in the measurement.

# **Magnetron Motion of Antiprotons in Microgravity**

## **WHY MEASURE ANTIMATTER GRAVITY IN SPACE?**

- 1. Microgravity provides greater sensitivity than gravity, e.g. stray gravity-induced DMRT, SB electric fields (up to 0.2 mg on Earth) are reduced by six orders of magnitude;**
- 2. The LTMPF of the ISS is ideal for traps, e.g. at 1.5 K Patch fields (up to 200 mg at 300 K) are thought to be one millionth mg, and thermoelectric fields are avoided due to temperature uniformity to  $< 0.001$  K/cm.**



## Evidence for a Temperature-Dependent Surface Shielding Effect in Cut

J. M. Lockhart, F. C. Witteborn,\* and W. M. Fairbank  
 Department of Physics, Stanford University, Stanford, California 94305  
 (Received 11 April 1977)

A large temperature-dependent transition in the magnitude of the ambient axial electric field inside a vertical copper tube has been observed. Above a temperature of 4.5 K the ambient field is  $3 \times 10^{-7}$  V/m or greater. Below 4.5 K, the magnitude of the ambient field drops very rapidly, reaching about  $-5 \times 10^{-11}$  V/m at 4.2 K. We believe that these effects result from the presence of a surface electron layer on the inside wall of the tube which provides a temperature-dependent shielding effect.

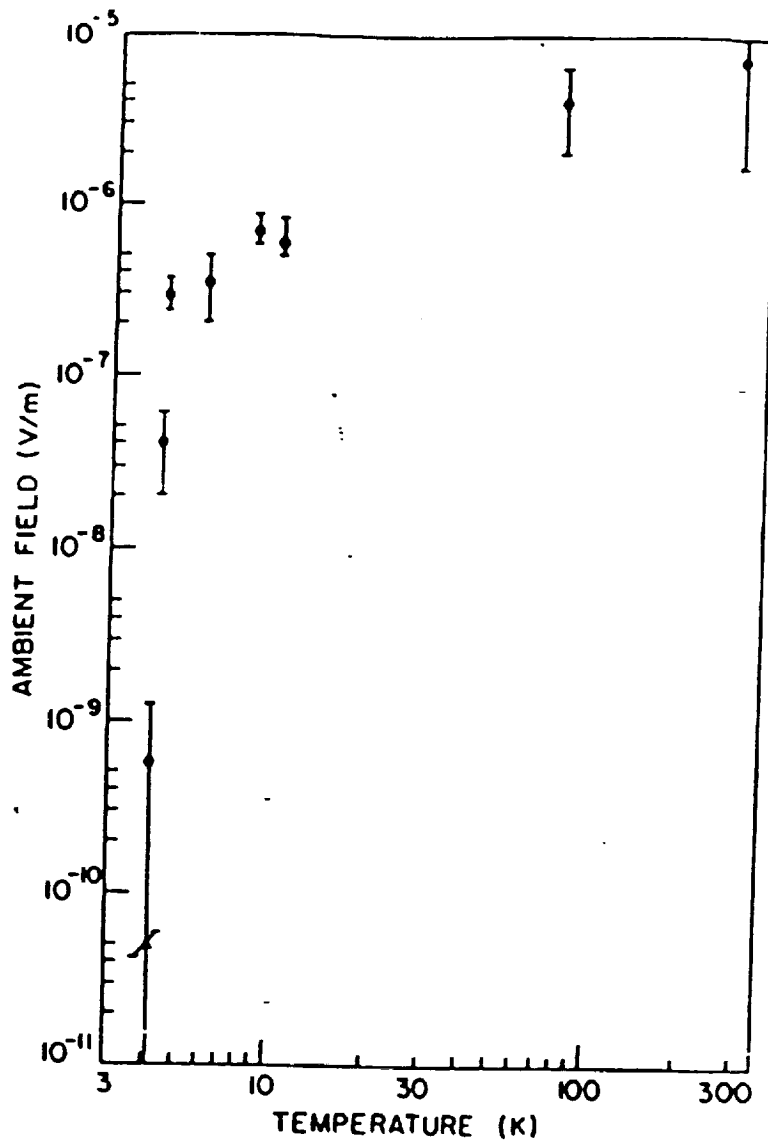

FIG. 2. The ambient electric field in the tube as a function of tube temperature. The closed circles show the present experimental results. The triangle shows the absolute value of the 1967 result of Witteborn and Fairbank, which was  $-5 \times 10^{-11}$  V/m at 4.2 K.

position  
 $m_9 = 5 \times 10^{-11}$  V/m

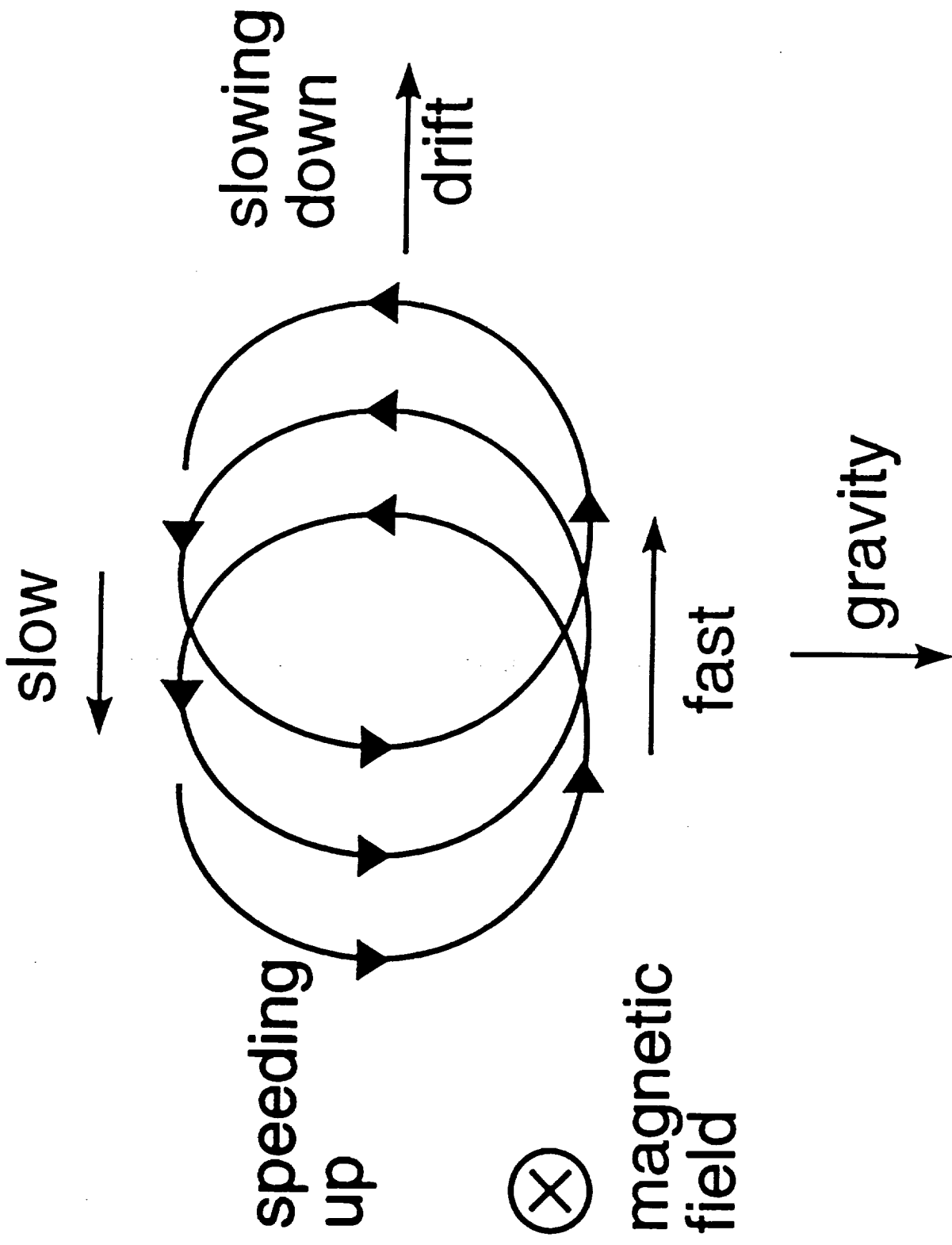

Figure 2:  $m\vec{g} \times \vec{B}$  drift in a uniform magnetic field

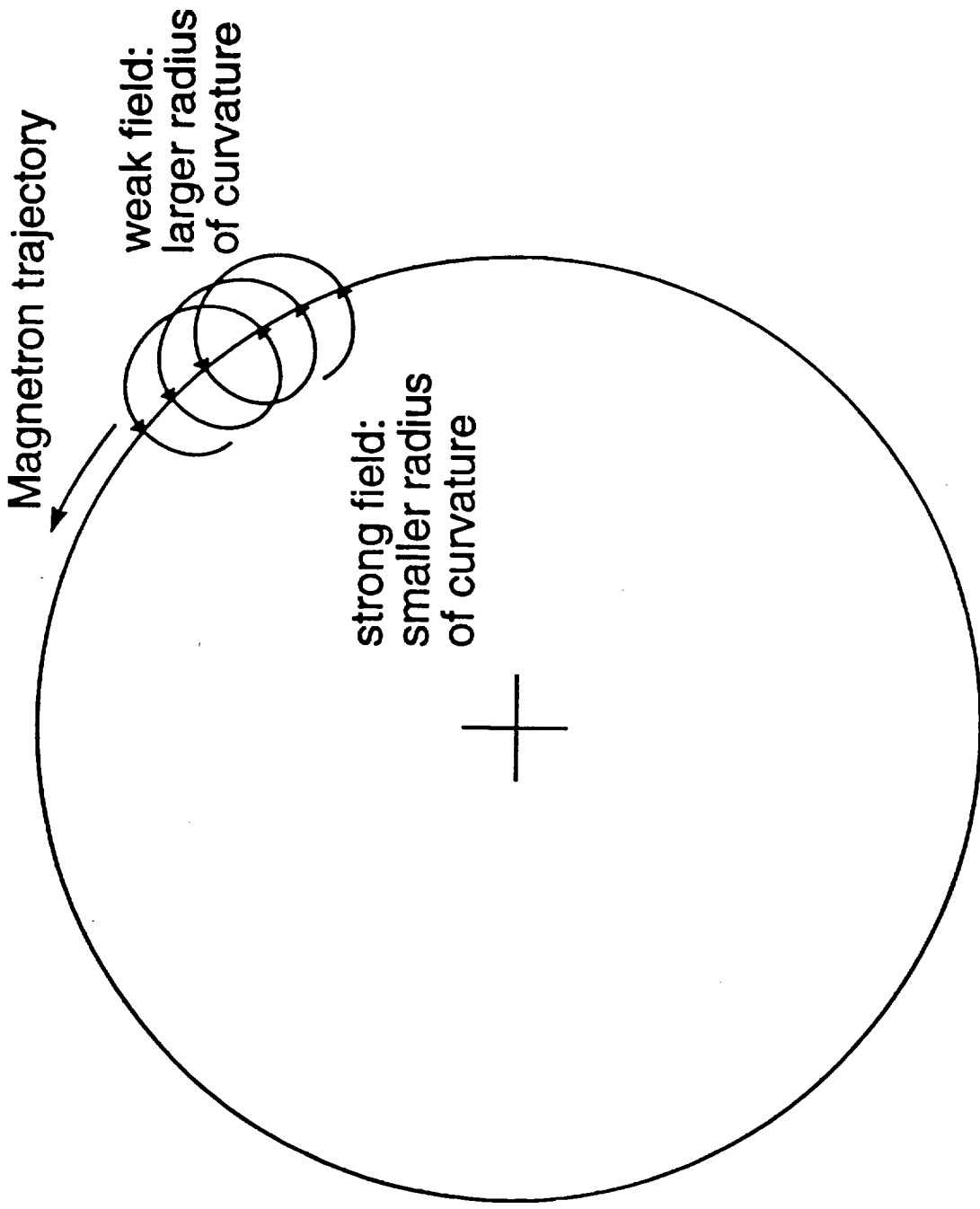

Figure 3: Magnetron drift motion due to the magnetic field gradient, independent of gravity

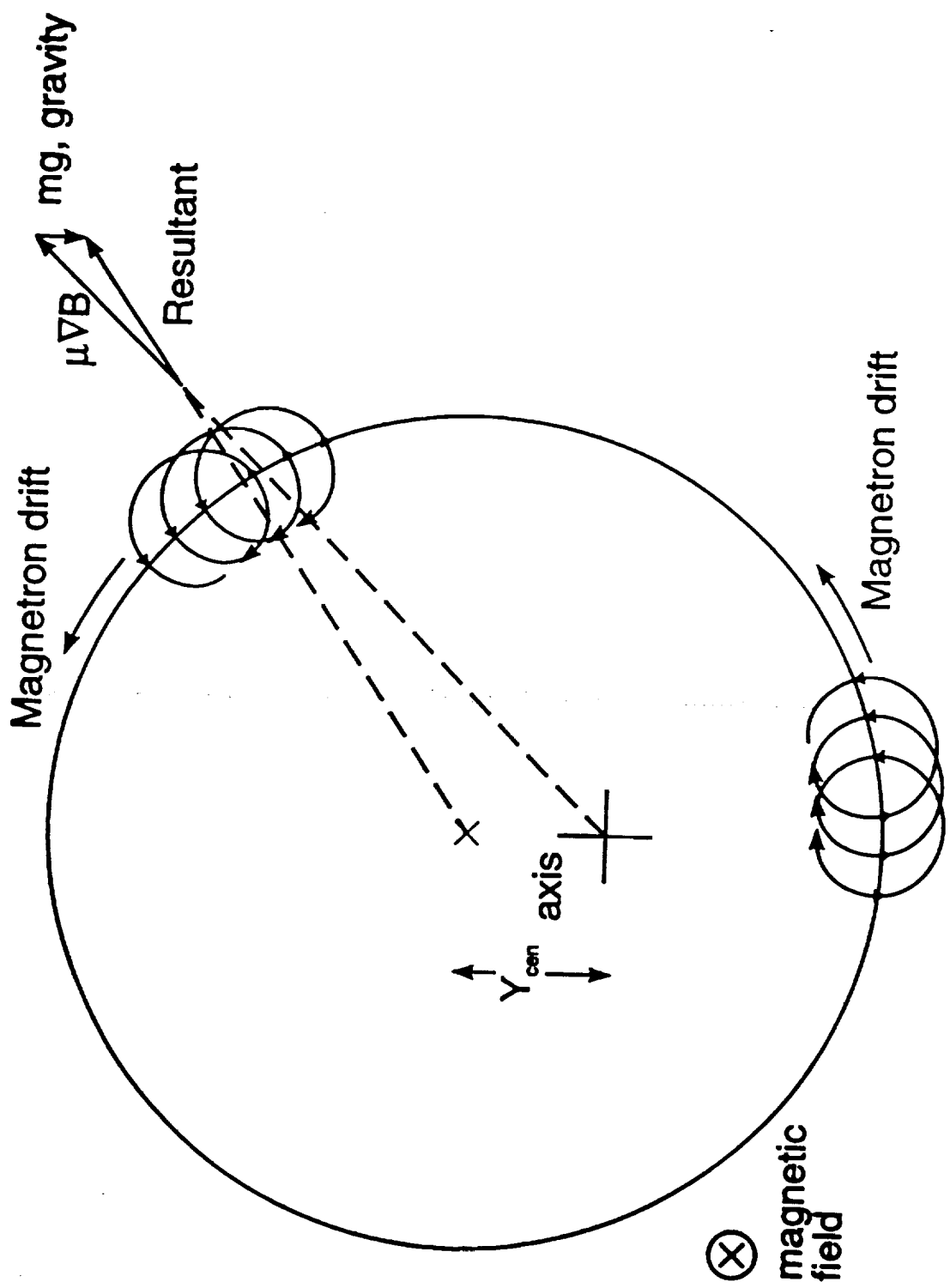
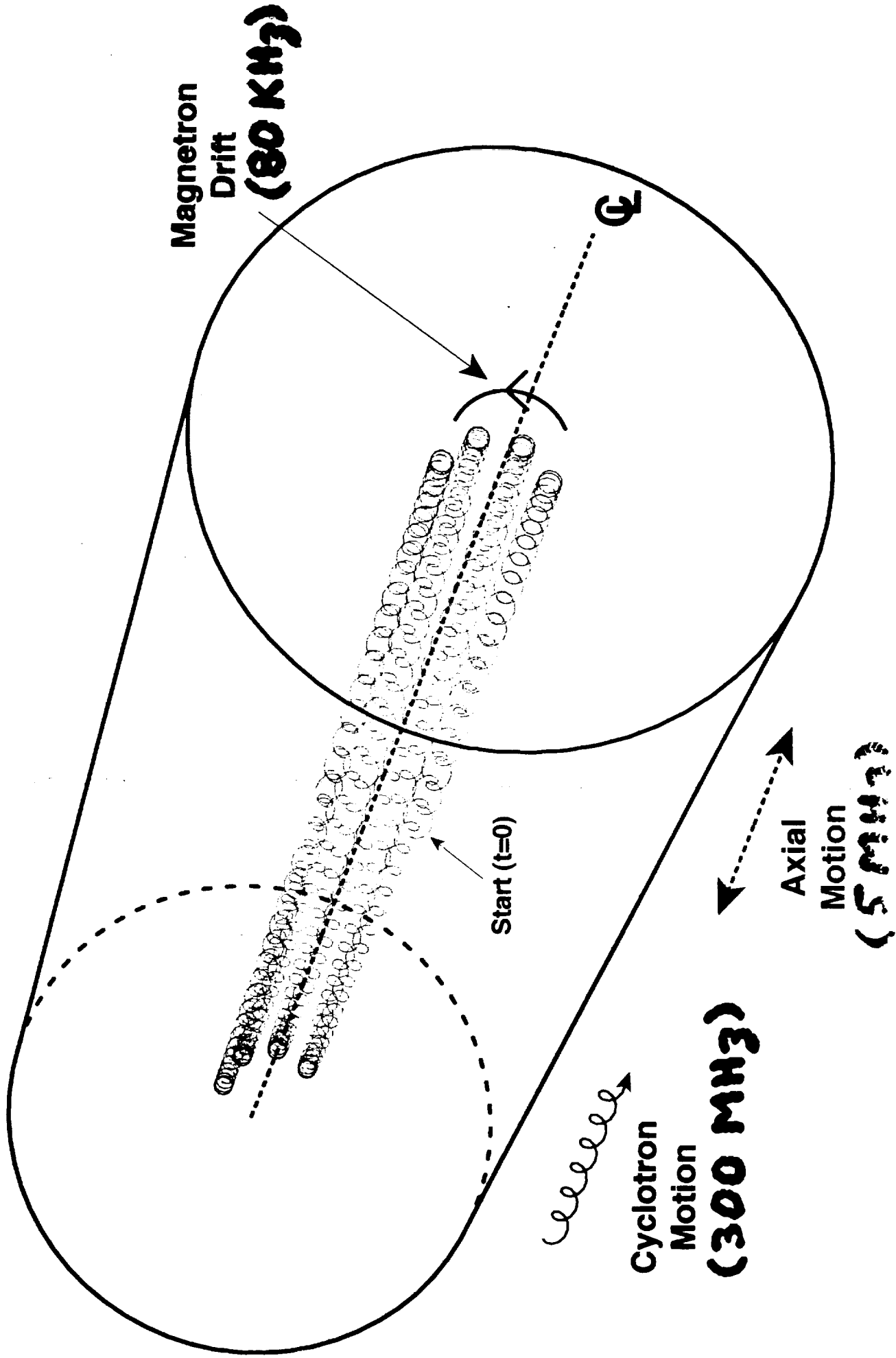

Figure 4: Combined effect of gravity and magnetron drift motions

# Antiproton Trajectory in a Penning Trap



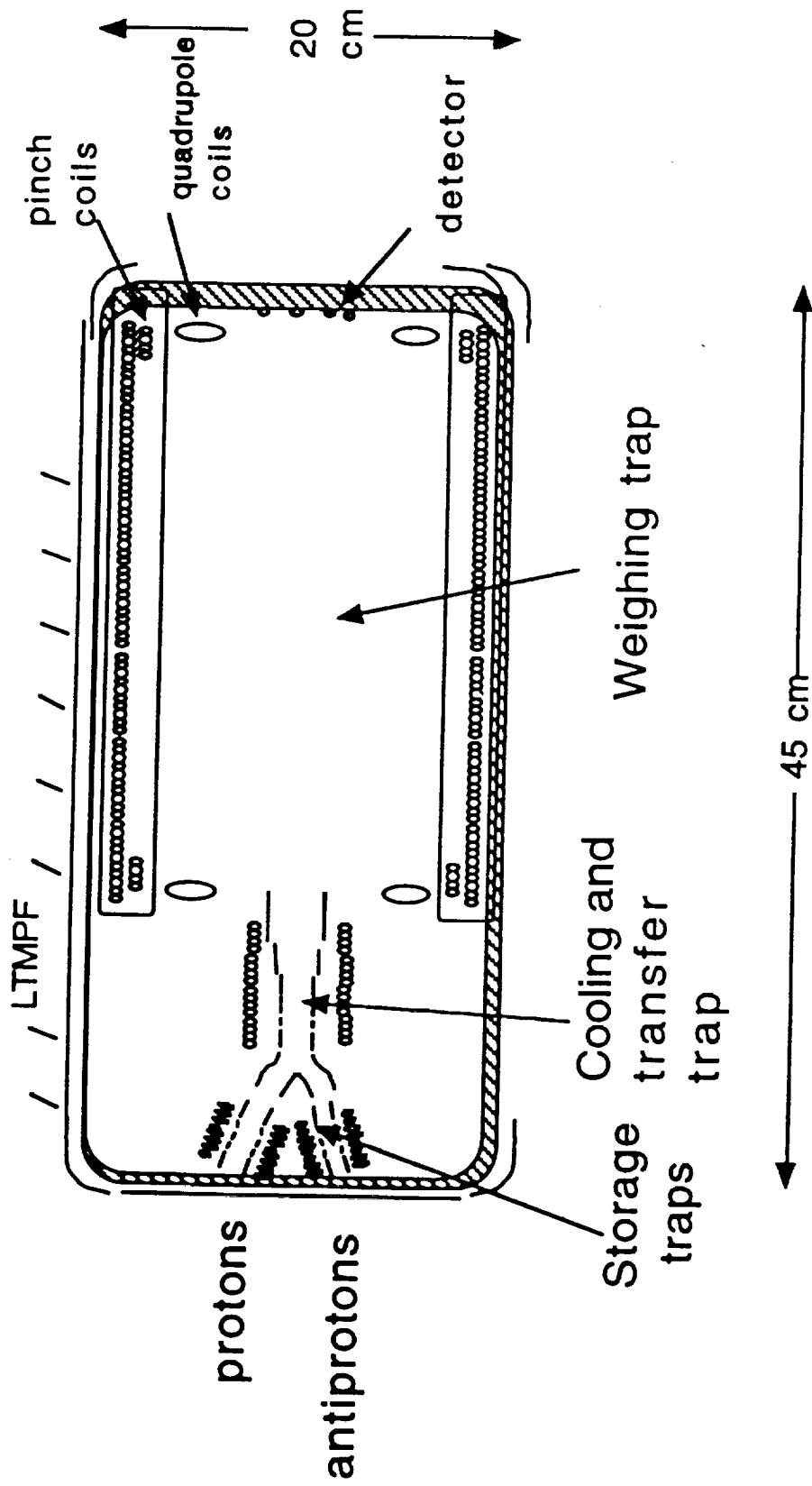

Figure 5: WEAX apparatus

# WEAX Sensitivity

4 dynamical equations, 10 parameters

$$\textcircled{1} \quad W = \frac{\alpha E_z y_{\text{cen}}}{z_{\text{max}}^2}$$
$$\textcircled{2} \quad T_m = \frac{2 \pi e B_0^2 z_{\text{max}}^2}{E_t B_2}$$
$$\textcircled{3} \quad R_c = \frac{\sqrt{2 m E_t}}{e B_0}$$
$$\textcircled{4} \quad B_0 E_z = B_2 E_t$$

6 constrained parameters

$W$ = weight of antiproton	$10^{-6}$ mg $\rightarrow$ mg
$T_m$ = magnetron period	$< 10^6$ sec.
$y_{\text{cen}}$ = center of magnetron motion above symmetry axis	$10 \mu\text{m}$ $\rightarrow$ 1 cm
$R_c$ = cyclotron radius	$\sim 10 \mu\text{m}$
$z_{\text{max}}$ = axial length of trap, consistent with LTMPF	10 cm
$\alpha$ = field shape parameter	0.1 $\rightarrow$ 1

4 unknown parameters

$E_z$  = axial antiproton energy  
 $E_t$  = transverse antiproton energy  
 $B_0$  = central magnetic field  
 $B_2$  = pinch field

**Table 2: Optimum parameters for earth, space measurements of antiproton gravity**

Weighing trap parameter	earth	microgravity
transverse energy of antiproton	$0.4\mu eV$	$0.01\mu eV$
central magnetic field $B_0$	100 Gauss	10 Gauss
pinch field $B_2$	56 Gauss	2 Gauss
cyclotron radius $R_c$	$9\mu m$	$15\mu m$
1/2 magnetron period	6200 sec.	840000 sec



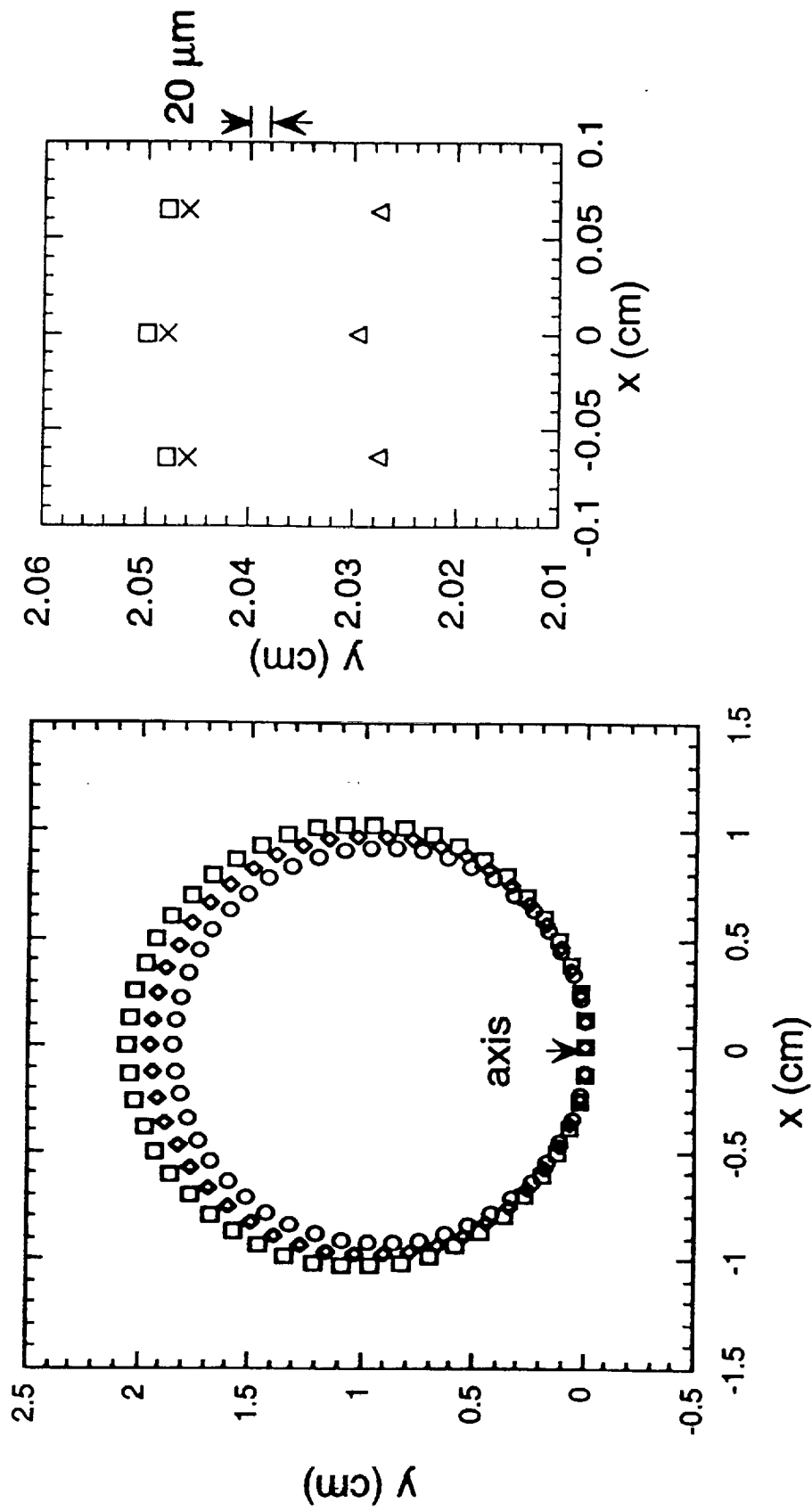

Figure 6: Optimum WEAX trajectories on earth for  $0.4\mu\text{eV}$  antiprotons: 1.0 mg (squares), 0.999 mg (crosses), 0.99 mg (triangles), 0.95 mg (diamonds), 0.90 mg (open circles). An exploded view of the trajectories near  $x=0$ ,  $y=2$  cm is shown at the right.

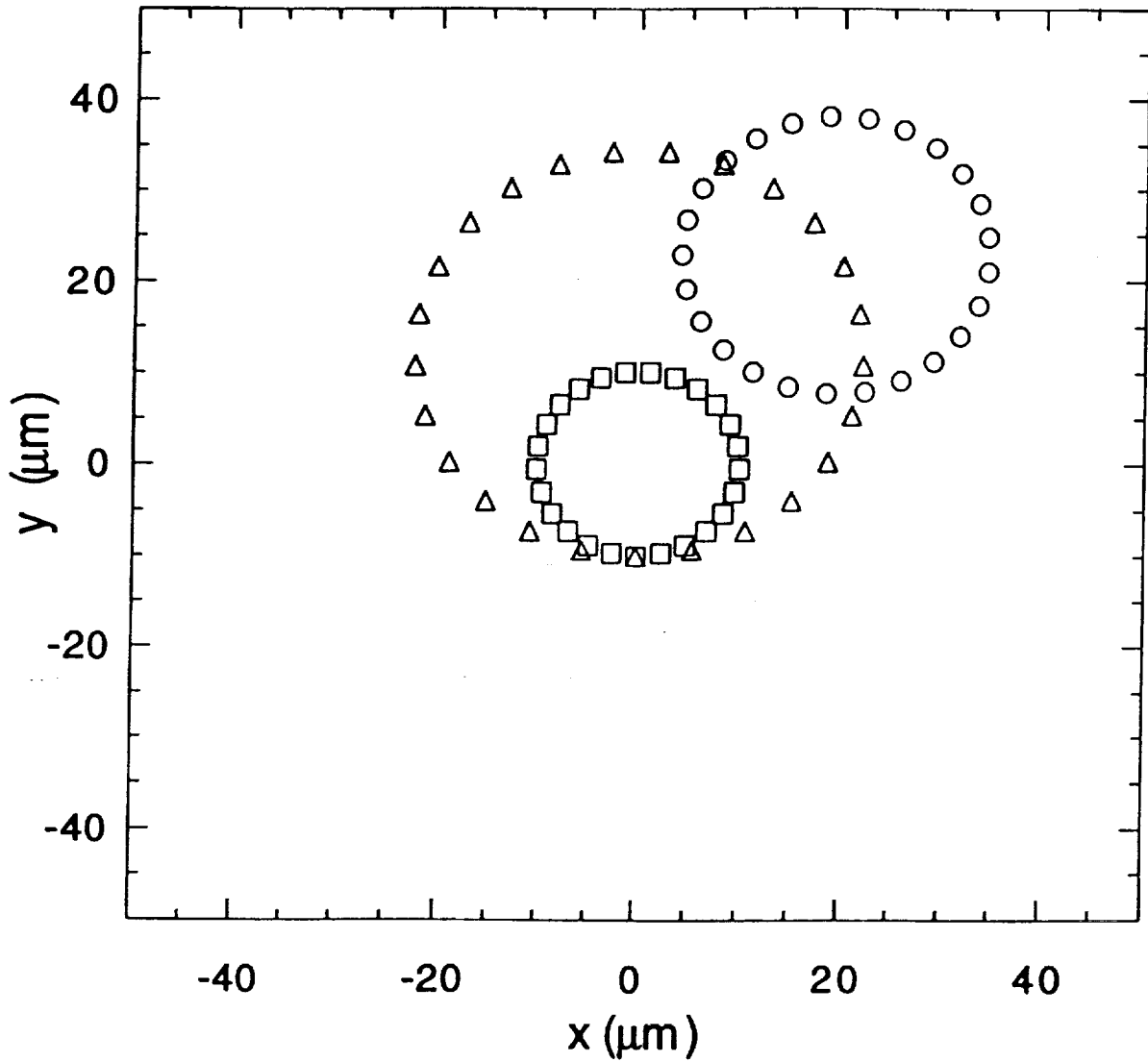

Figure 7: Optimum WEAX trajectories in microgravity for  $0.01\mu eV$  antiprotons:  $10^{-6}$  mg (triangles),  $10^{-8}$  mg (squares). A typical cyclotron orbit (circles) is shown.

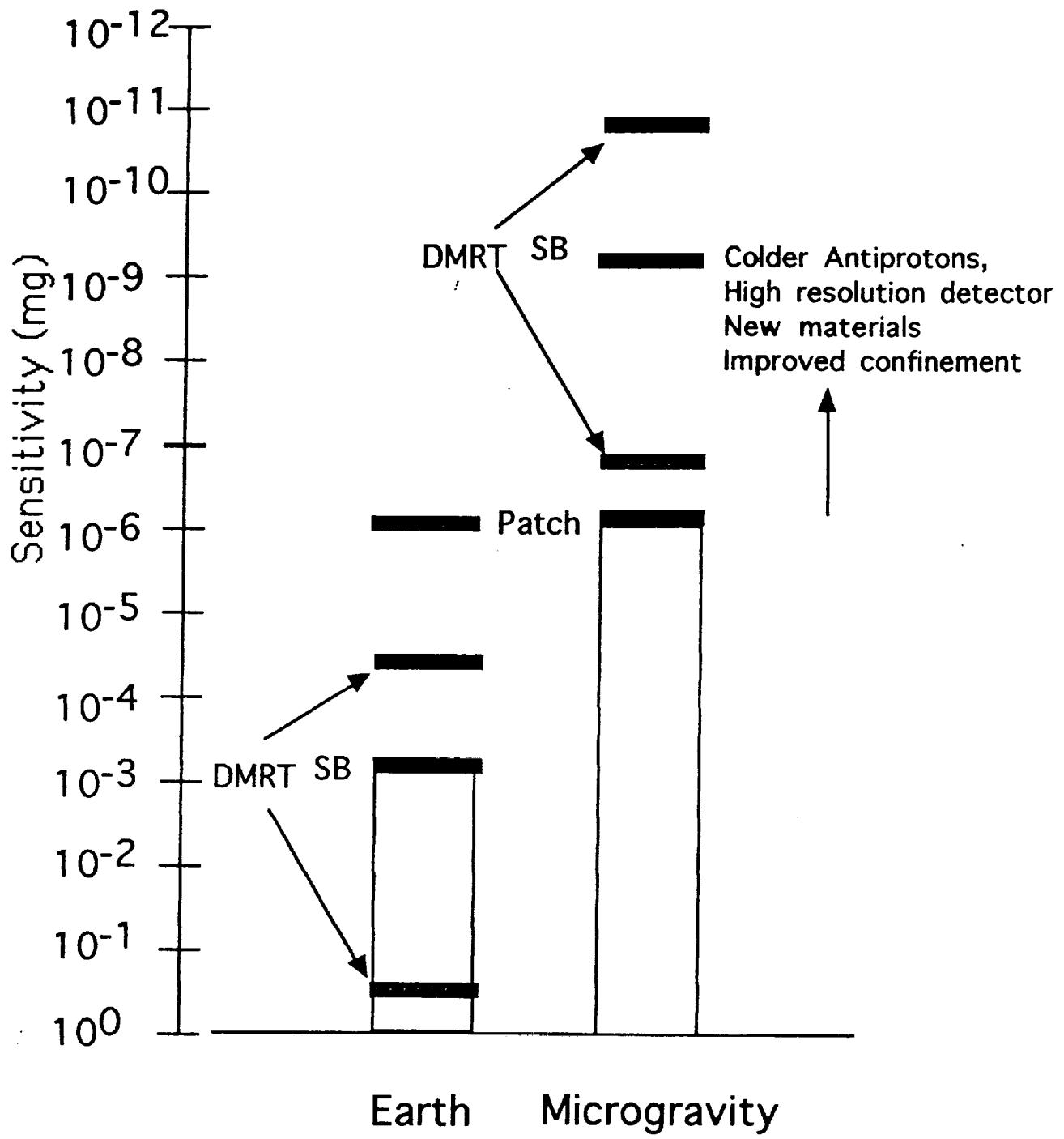

Figure 8 -- WEAX sensitivity

E. Messerschmid, R. Bertrand, F. Pohlemann

# Raumstationen

Systeme und Nutzung

Konzeptversion  
Dezember 1996

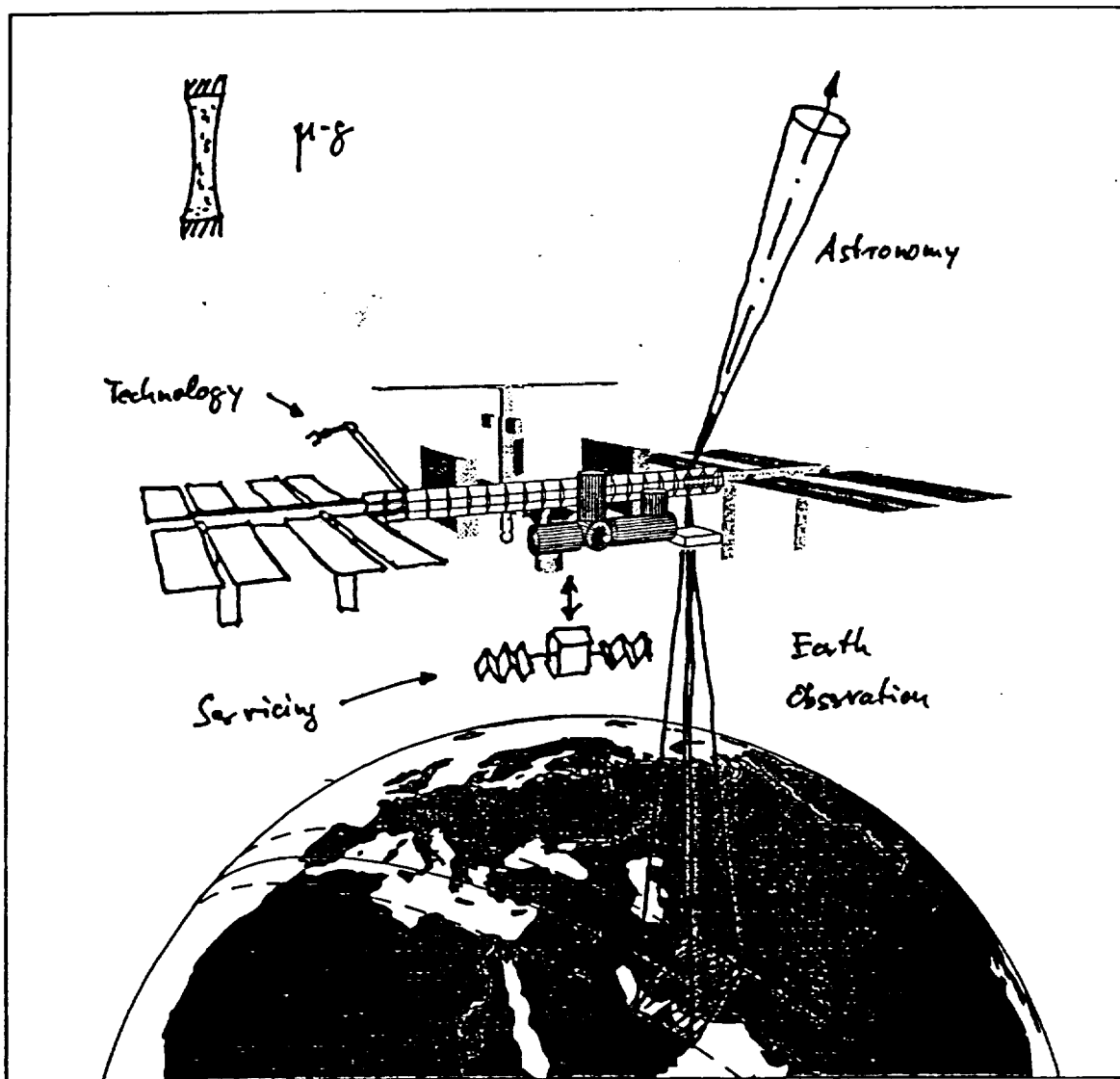

UNIVERSITÄT STUTTGART  
INSTITUT FÜR RAUMFAHRTSYSTEME

**Life On Earth.**

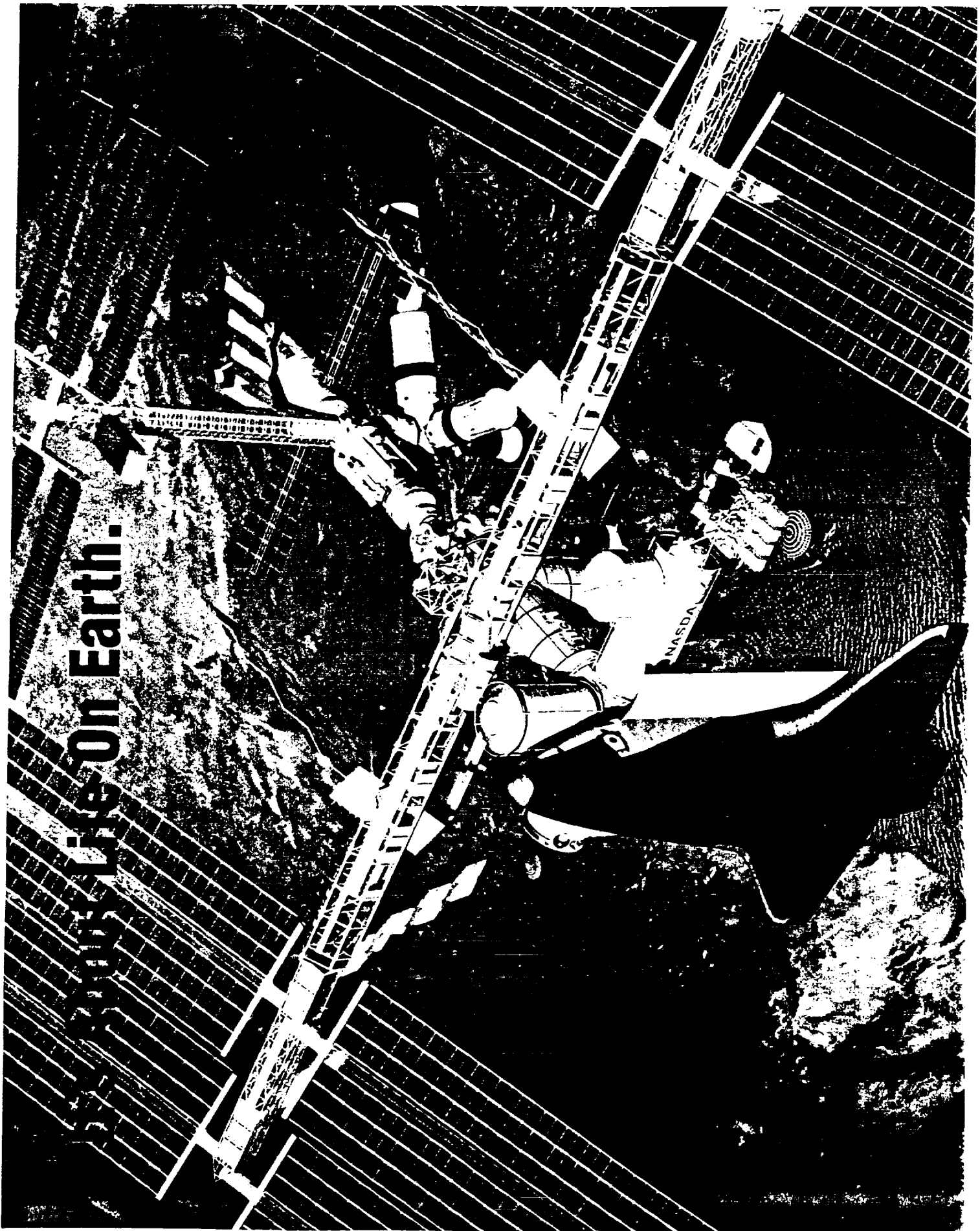

# WEAX on ISS

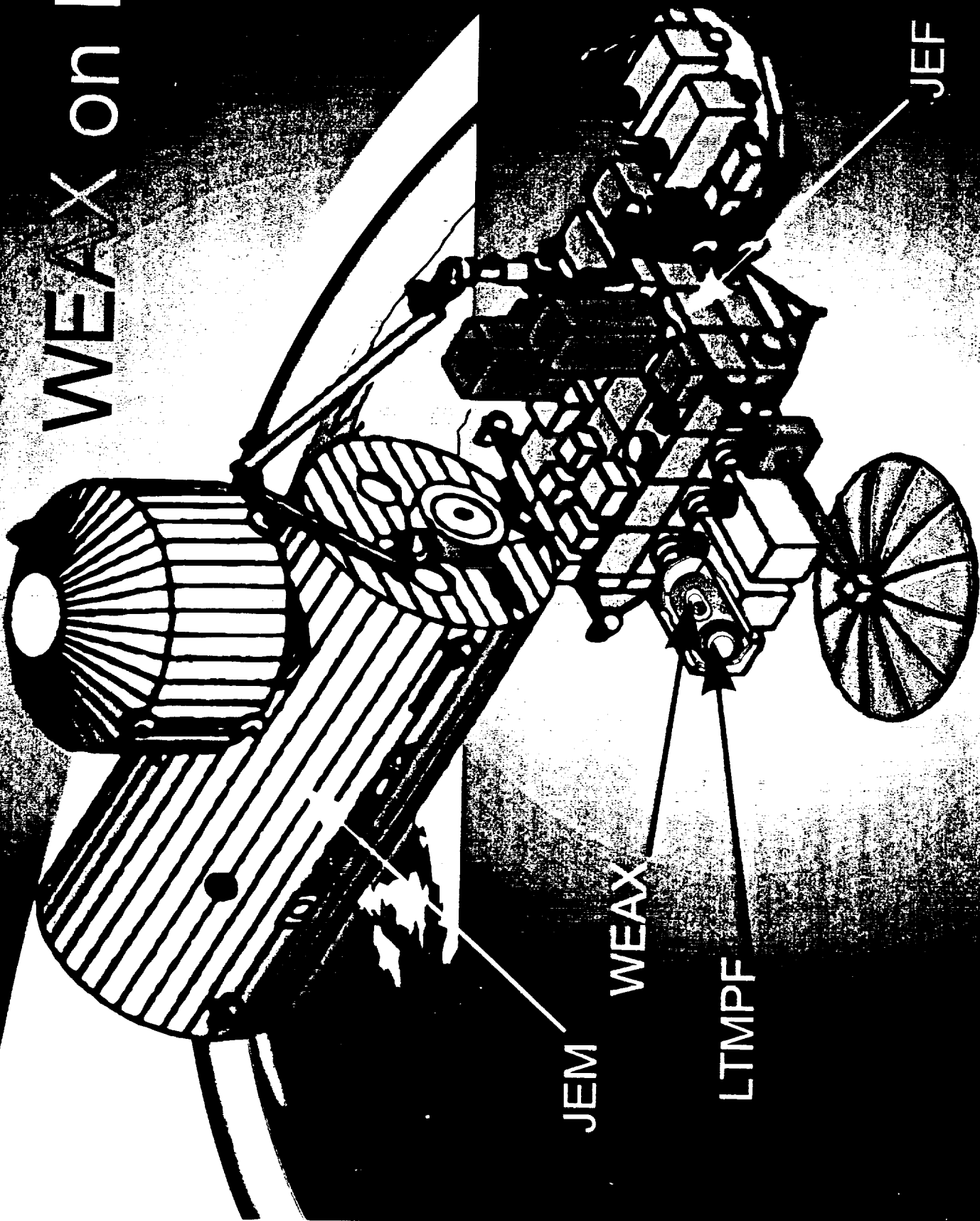

JEM

WEAX

LTMPPF

JEF

# **ANTIMATTER & PROPULSION**

## WHY ANTIMATTER FOR PROPULSION?

	PROPELLANT	ENERGY DENSITY (J/kg)
Chemical	$H_2 + O_2$	$1.3 \times 10^7$
Fission	$U^{235}$	$8.2 \times 10^{13}$
Fusion	$D + D$	$7.9 \times 10^{13}$
Antiproton	$\bar{p} + p$	$9.0 \times 10^{16}$



**J. CALLAS**

1987

[Isp = 5000s - 100000s]

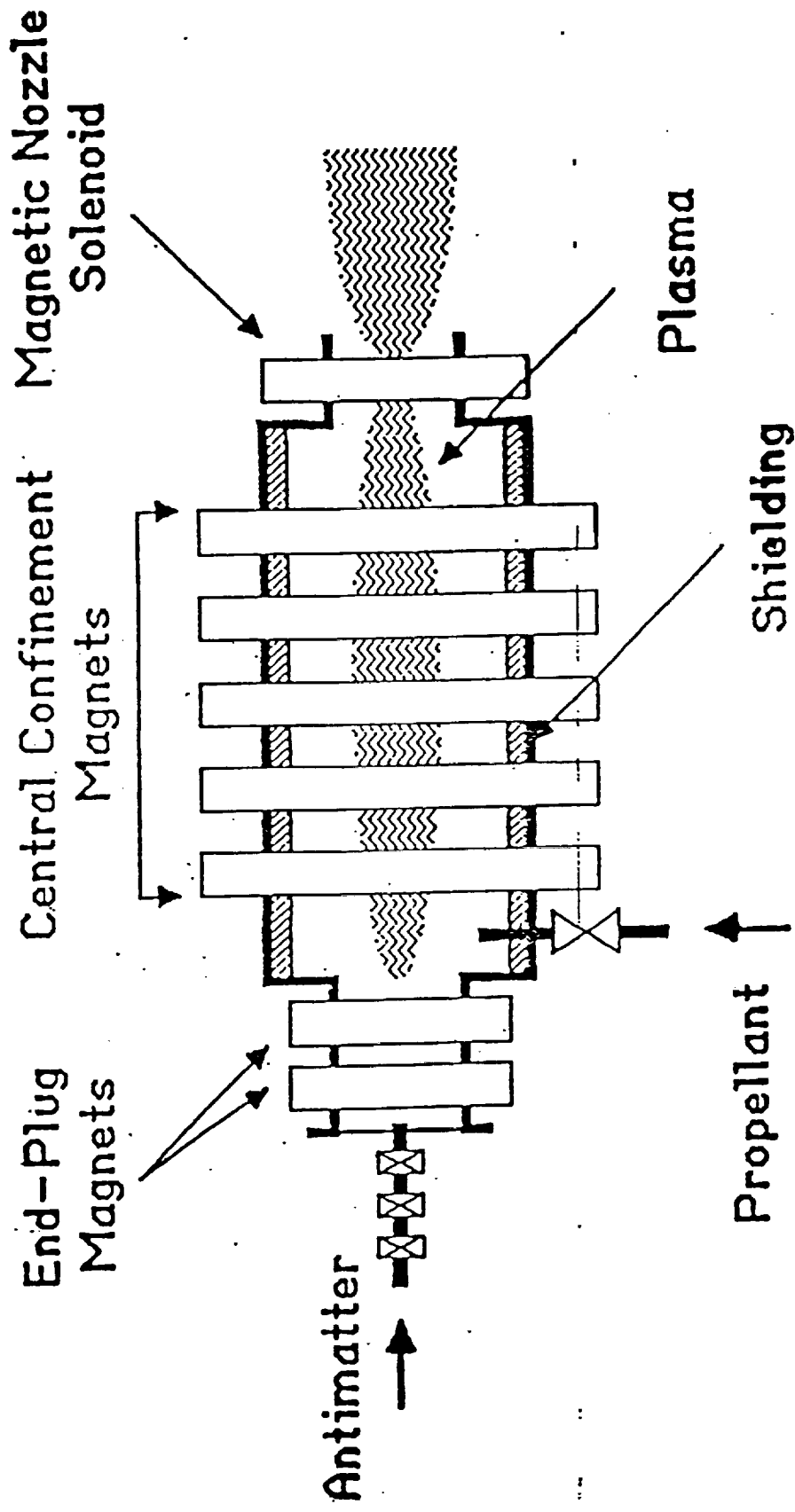

**EFFICIENCY  $\approx$  10 ---> 100 MICROGRAMS PER CYCLE!**

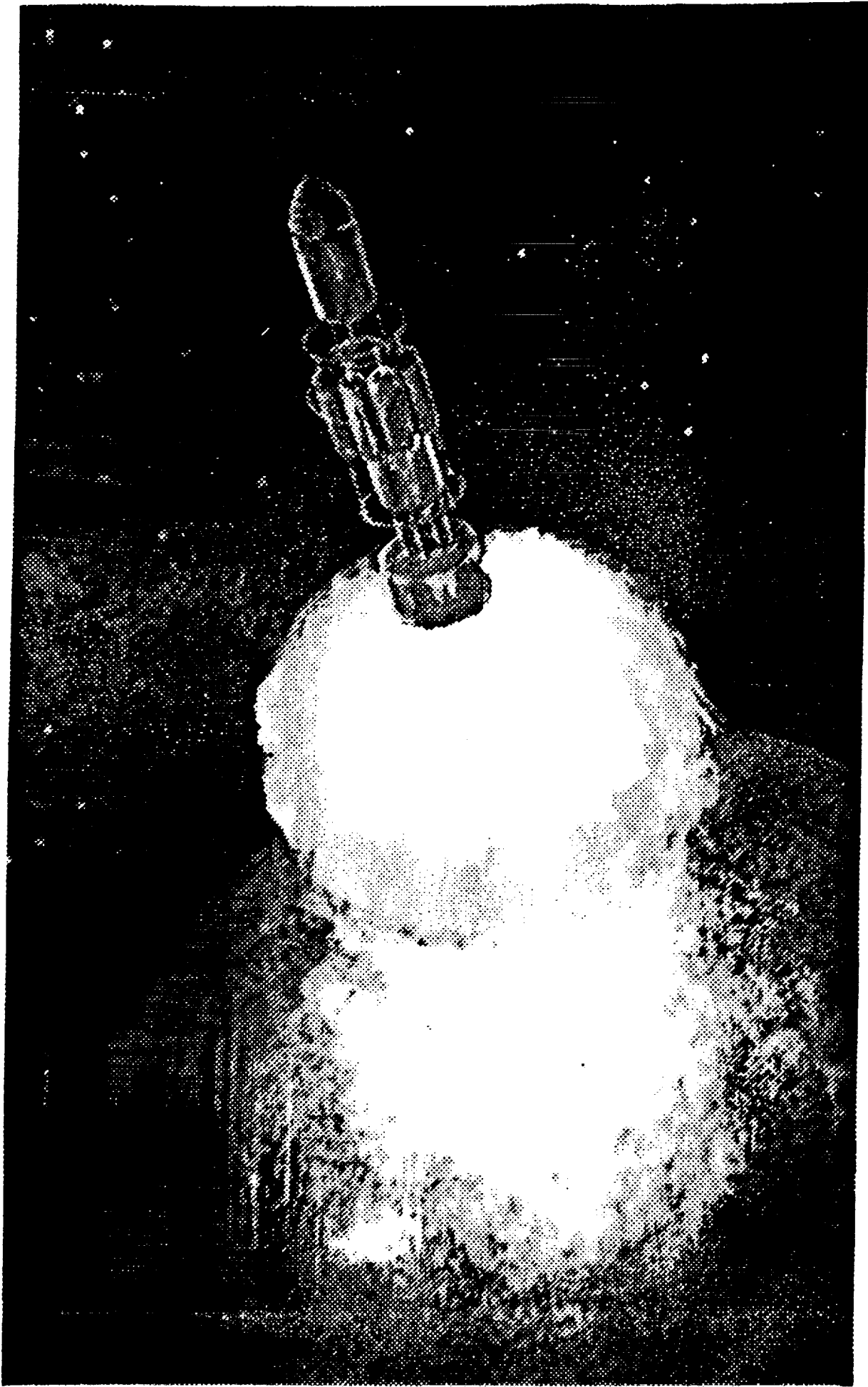

*Yeoman Dyson's Orion Starship on an Interstellar Journey.*

## **AIMStar: A Probe for Deep Space Exploration**

- **Use the large specific energy of portable antimatter to exploit the attractive features (e.g. large Vex) of nuclear fusion:**
- **Create a reliable low mass AIM engine that provides continuous and high specific power;**
- **Demonstrate attractive missions, e.g. 50 years to 10,000 A.U., with practical operating parameters.**

# Aerospace Daily

December 12, 1997

Vol. 184, No. 50; Pg. 397

## JPL studying technologies for interstellar precursor mission

Researchers at NASA's Jet Propulsion Laboratory are studying just what it would take to mount a precursor mission to the stars within 50 years that would send a robotic spacecraft 10,000 times as far away from Earth as Earth is from the sun.

A propulsion workshop at the California facility on Monday produced data on several different propulsion techniques with the potential to carry out the mission Administrator Daniel S. Goldin proposed in a July 3 speech at JPL, the day before Mars Pathfinder landed on the Red Planet. In that speech Goldin asked JPL to evaluate technologies for the "interstellar precursor" mission, which would set the stage for eventual exploration of nearby stars.

Goldin proposed sending a spacecraft 10,000 astronomical units (A.U.) from Earth - roughly one-sixth of a light year or 1/25th of the distance to Proxima Centauri, the nearest star - in 50 years, with 25 years allowed between the start of development and first launch. The trouble is, the technology for even a precursor mission to the stars does not exist today.

"We do not have any propulsion system today that is anywhere near the capability we would need," said JPL's Stephanie Leifer in a telephone interview. "It's a very difficult problem." Leifer and Robert Frisbee of JPL's advanced propulsion technology group are jointly heading up a study of how to meet the propulsion portion of Goldin's challenge. In Monday's workshop advanced propulsion re-

searchers from around the country proposed a half-dozen different concepts for reaching 10,000 A.U., which Leifer and her colleagues will analyze over the remainder of fiscal 1998.

Ultimately the interstellar precursor mission study hopes to produce a breakout of performance parameters for the different concepts, along with research and development roadmaps that could lead to an operational propulsion system. One key to vaulting such large distances within a reasonable time is high energy density in the propulsion system, and the JPL workshop addressed several ways that in theory could provide the densities needed.

Those included nuclear fusion, extremely high power beamed energy and very high-power nuclear electric propulsion. In the last case, even if a nuclear electric plasma propulsion system could be built that could push a spacecraft to 10,000 A.U., its performance would not be up to an interstellar mission, Leifer said.

High-power fusion does hold promise for interstellar propulsion, she said, but despite billions of dollars spent on research, nuclear fusion has never proved a practical energy source on Earth, where efficiency is measured in dollars per kilowatt. The story might be different in space, where the efficiency equation measures kilowatts per kilogram.

As an example of the type of directed research that could grow out of the JPL study, Leifer said

work already underway at Pennsylvania State University on trapping anti-protons could one day lead to anti-matter initiated fusion for space propulsion.

Aside from the value of a 10,000 A.U. mission as a technology demonstrator, valuable science can be conducted at such distances even without reaching another stellar system, Leifer said. Well within the 10,000 A.U. range a spacecraft would pass the heliopause, where the solar wind dies out, while infrared measurements of celestial bodies get better because zodiacal dust thins as the sun recedes.

Astronomy today relies on a baseline of only two A.U. - the distance across the orbit of the Earth around the sun - for parallax measurements of celestial distances. With a baseline of 10,000 A.U., those measurements would be correspondingly more precise, Leifer said.

Even if the precursor mission is never undertaken, the propulsion advances that would make it possible would make travel around the solar system much quicker and more direct, without the need for the time-consuming gravity assists and energy-saving trajectories that characterize today's robotic planetary missions.

"If you ask me today can we go to 10,000 A.U., I'd have to say no," Leifer said. "But given the possible developments we can make in the next 10 to 25 years, the answer is yes."

## Fusion Reactions for Space Applications

### A. The most important fusion reactions for space applications



### B. Other Desired (Aneutronic) Reactions (energetically very difficult)

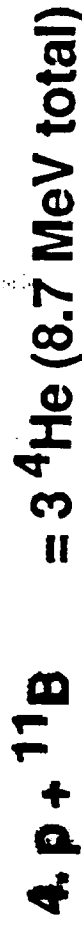

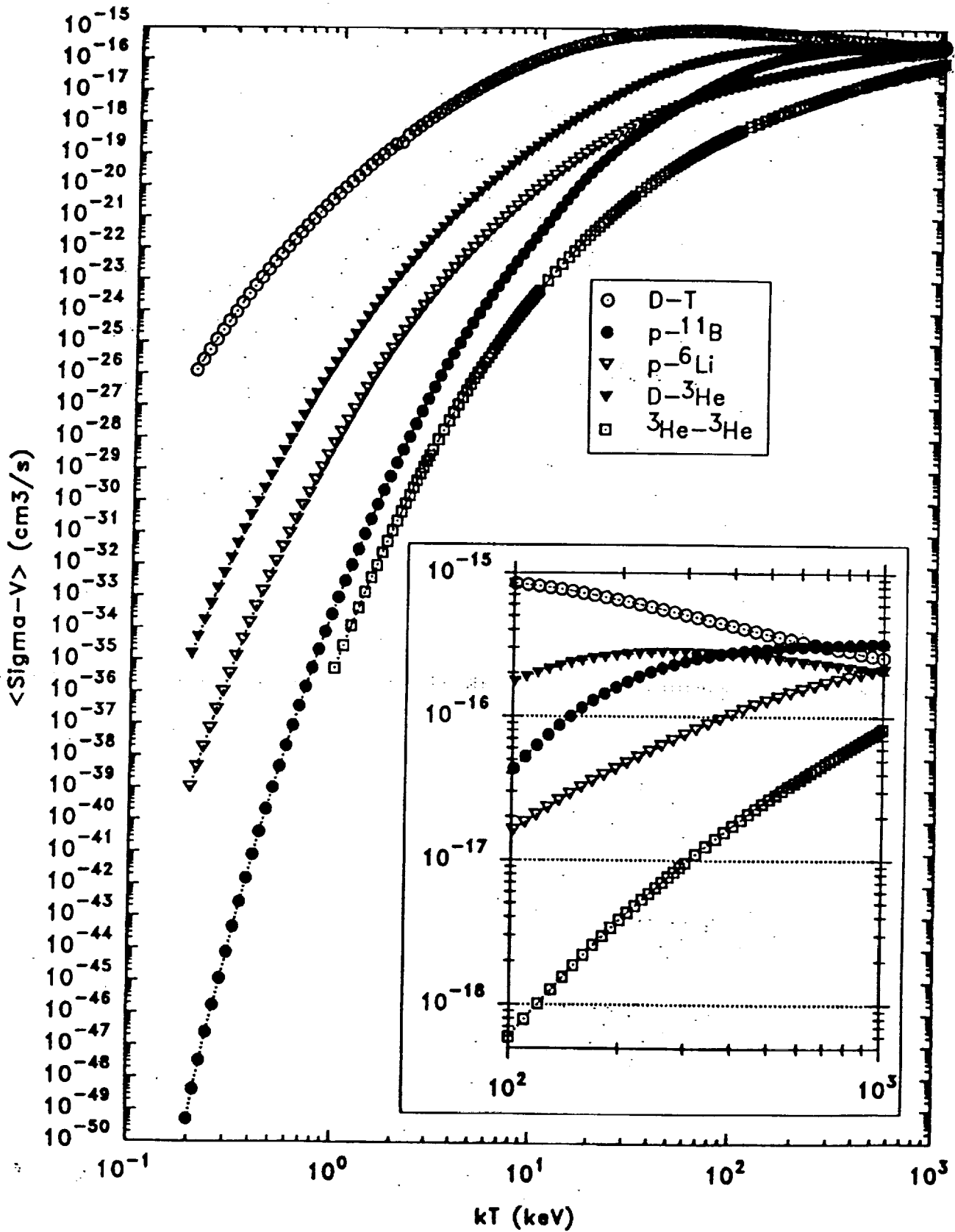

# Reaction trap electrode structure (20 T axial magnetic field)

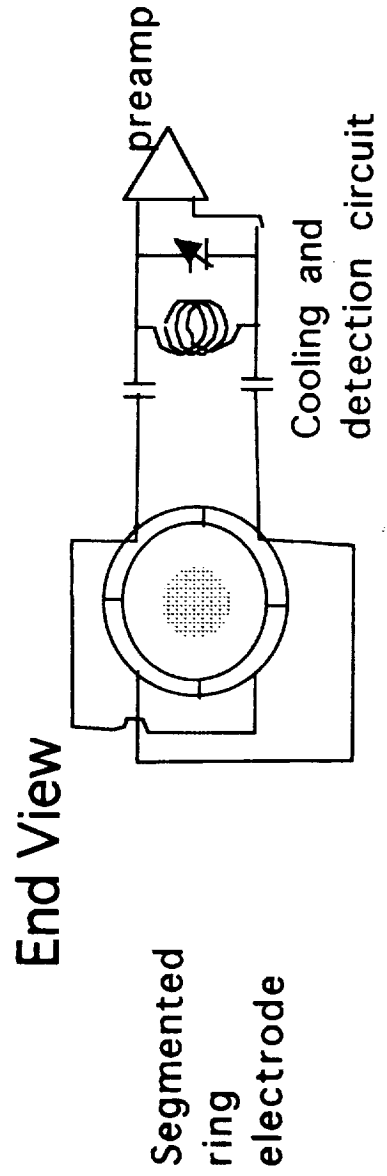
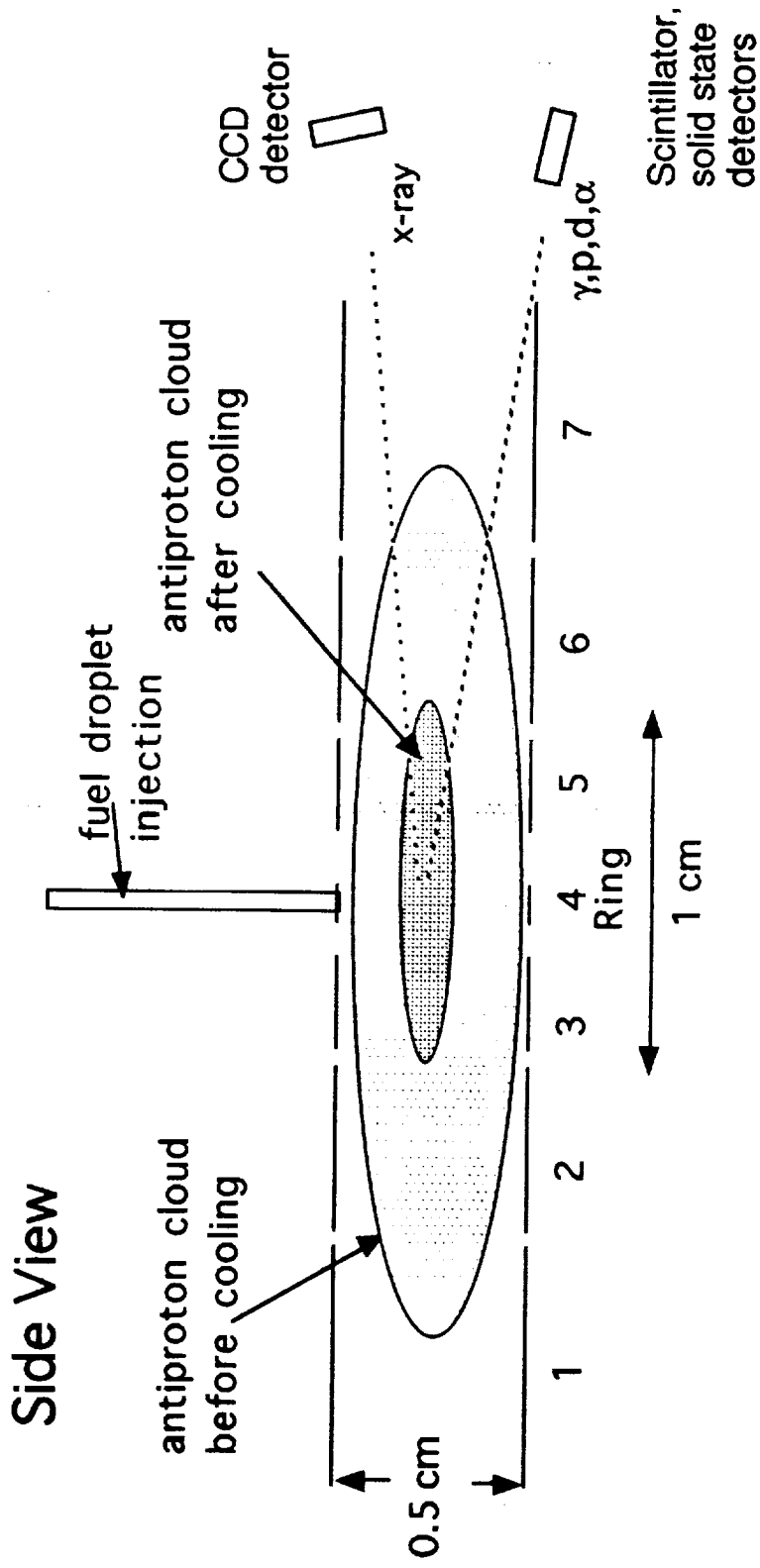

# Fusion cycle, part 1. Injection of fusion fuel

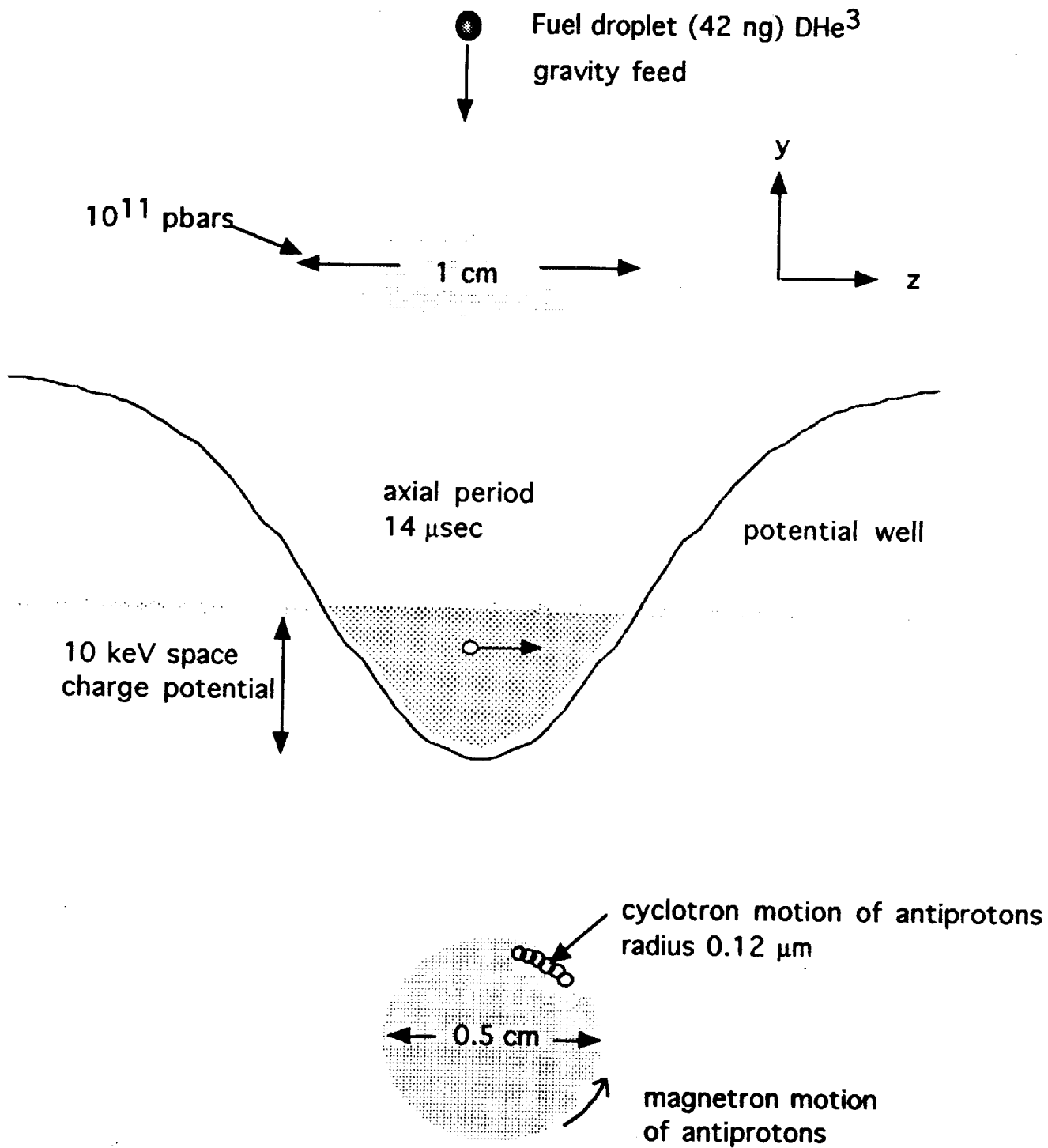



AIM PRE-HEATING POWER DENSITY

42 ng D-He<sup>3</sup> droplet,  $5 \times 10^8 \bar{p}$ 's, 2% molar mix of U<sup>238</sup>

$$PD = 5 \times 10^8 \bar{p}'s \times 200 \times 10^6 \text{ eV}/\bar{p} \times 1.6 \times 10^{-19} \text{ J/eV}$$

$$10^{-9} \text{ sec.} \times (0.44 \times 10^{-2})^3 \text{ cm}^3$$

$$= 1.9 \times 10^{14} \text{ W/cm}^3$$

# Laser ICF Systems



Fig. 1 GEKKO XII glass laser system  
 Output energy 30 kJ in 1.05  $\mu\text{m}$  wavelength, 20 kJ in 0.53  $\mu\text{m}$ ,  
 15 kJ in 0.35  $\mu\text{m}$

$$PD = 5.3 \times 10^{13} \text{ W/cm}^2$$

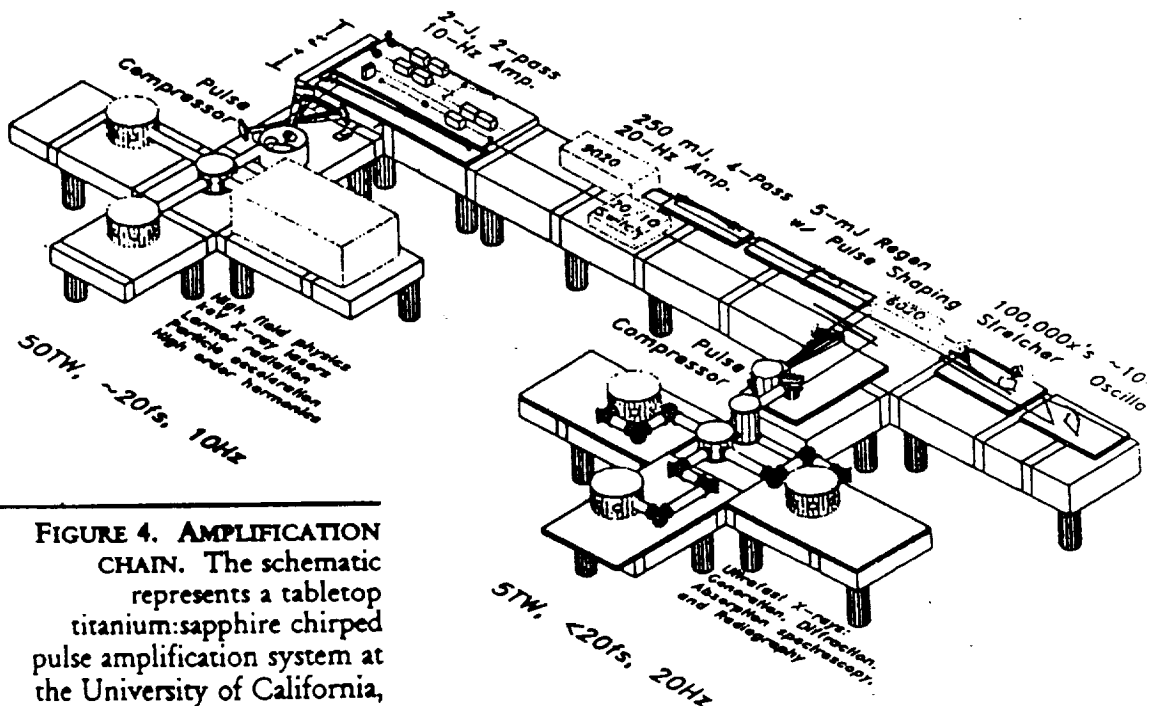

FIGURE 4. AMPLIFICATION CHAIN. The schematic represents a tabletop titanium:sapphire chirped pulse amplification system at the University of California, San Diego, that can produce 5 TW and 50 TW laser pulses.

$$PD \approx 10^{14} - 10^{15} \text{ W/cm}^2$$

# Fusion cycle part 2.

Initial heating and confinement of fusion fuel by pbars

y-z view

②

$5 \times 10^8$  antiprotons annihilated on periphery of cloud in 1 ns.

①

DHe<sup>3</sup> droplet entering antiproton cloud

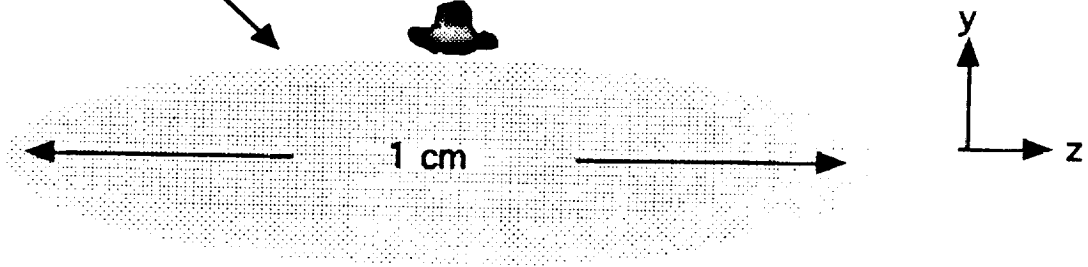

③ Apply weak nested well potential

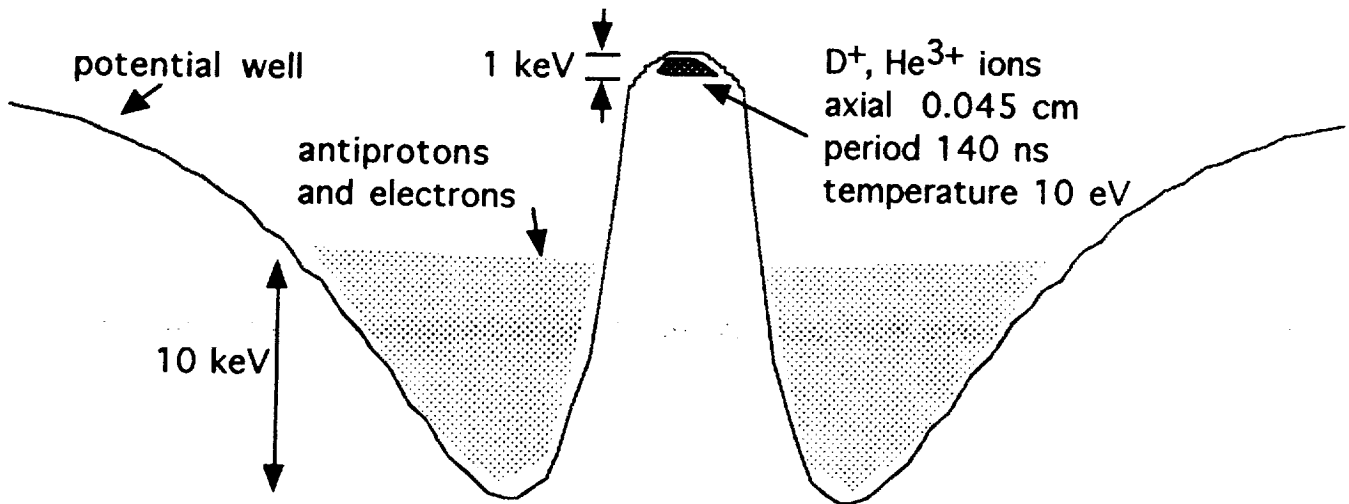

x-y view

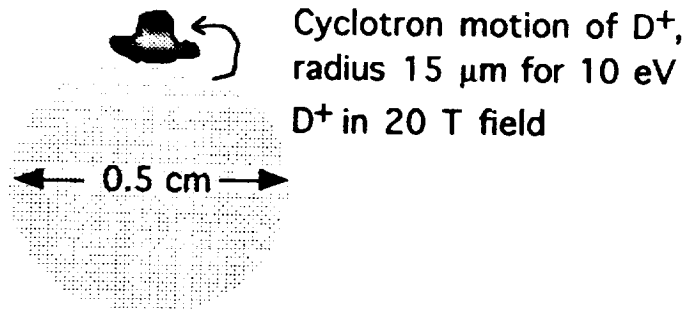

# Fusion cycle part 3.

20 msec fusion burn at 100 keV

① Apply strong nested well potential

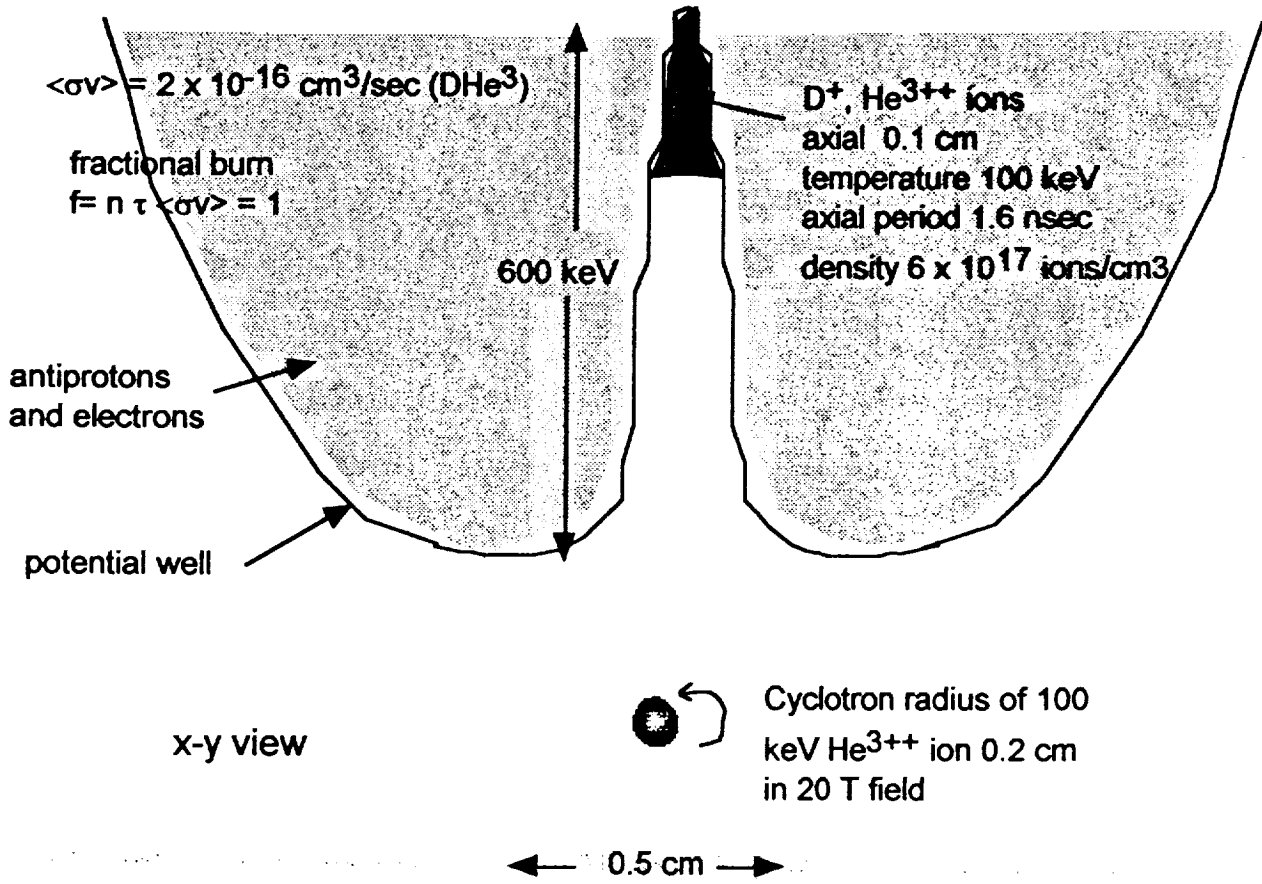

y-z view

②  $\text{D}^+ + \text{He}^{3++} \rightarrow \text{p (14 MeV)} + \alpha \text{ (3 MeV)}$

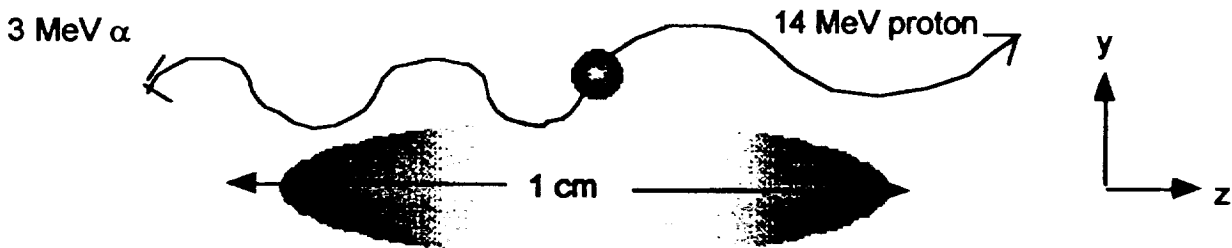

# Summary of Confinement Techniques

	Central density	Well depth for ions	Well depth for electrons	Electric field gradient
AIM nested-well Penning trap	$6 \times 10^{17}/\text{cm}^3$	600 keV	600 keV	1200 keV/cm
Polywell magnetic cusp (R.W. Bussard, Fus. Tech. 19, 273, 1991) (N.A. Krall, Fus. Tech. 22, 42, 1992)	$2 \times 10^{18}/\text{cm}^3$	110 keV	200 keV*	100 keV/cm
Single-well Penning trap (D.C. Barnes, R.A. Nebel, L. Turner and T.N. Tiourine, Plasma Phys. Control. Fusion 35, 929, 1993 )	$2 \times 10^{19}/\text{cm}^3$	60 keV	120 keV	600 keV/cm

\*magnetic

## Dynamical manipulation of electron density in nested-well trap

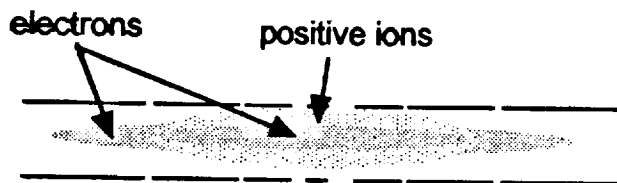

STATIC CONFINEMENT OF BOTH + AND - CHARGES IS IMPOSSIBLE, SINCE CHARGES MOVE TO MAKE  $\Phi = \text{CONSTANT}$  INSIDE A PLASMA. USE DYNAMIC PROCESS:

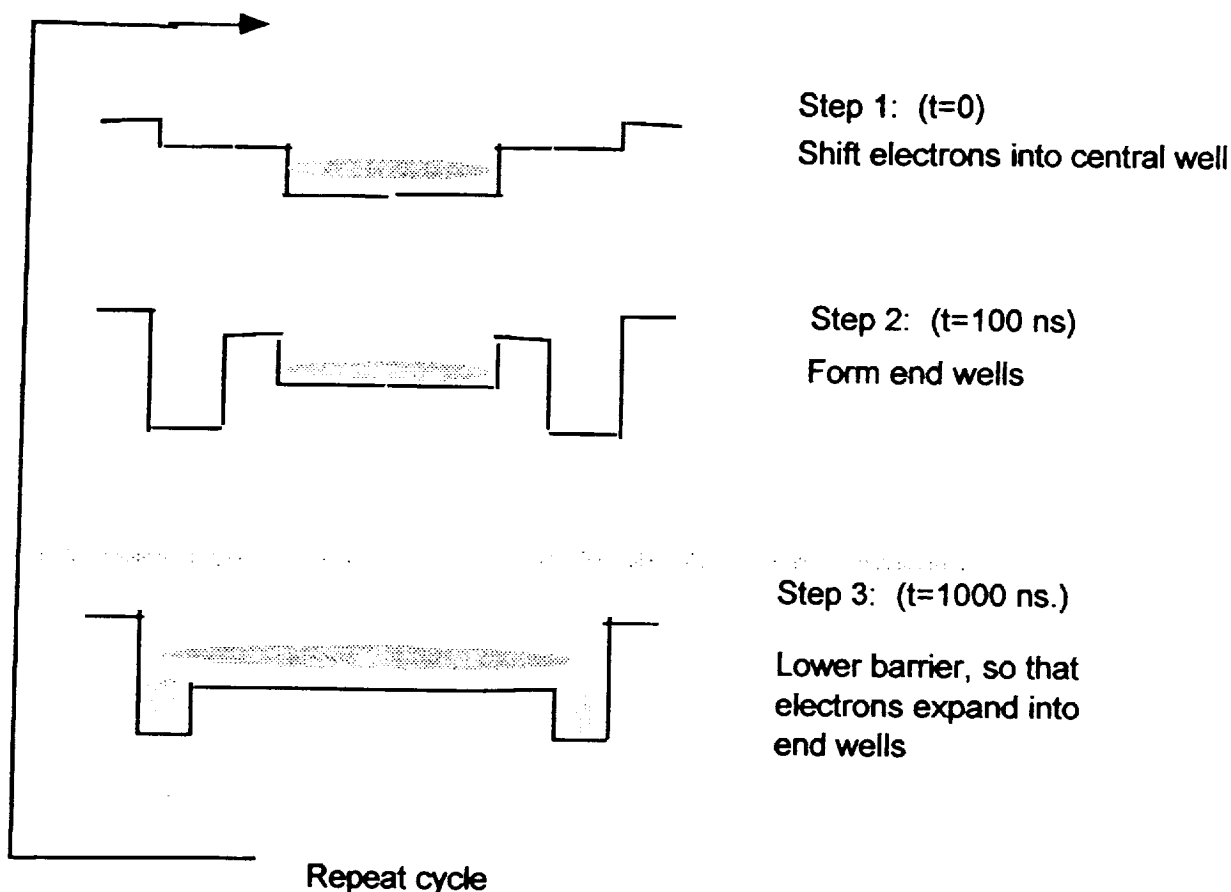

THE ELECTRONS ARE HEATED AS THEY FALL INTO THE END WELLS, MAKING THE ELECTRON DENSITY LOWER THAN IN THE CENTRAL WELL, WITHOUT REPEATING THE CYCLE, THE ELECTRONS WOULD COOL DOWN, INCREASING THE DENSITY IN THE END WELLS AND REDUCING AXIAL CONFINEMENT OF THE POSITIVE IONS.

# Radiation and Power Losses

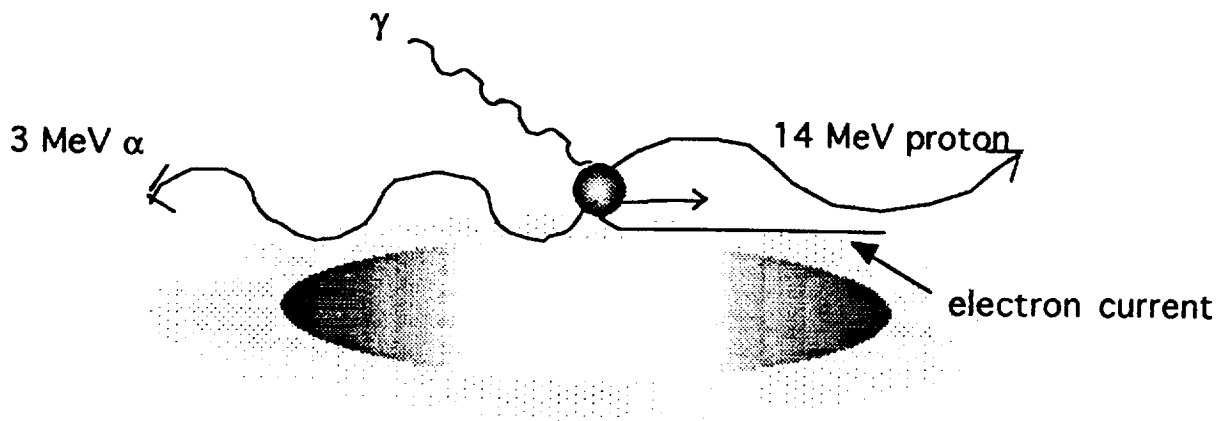

Fusion power	750 kW
Bremsstrahlung loss	24 kW
Synchrotron radiation	2 kW
Electron current (8 A @ 5 keV)	<u>40 kW</u>
Net Power	684 kW

# Fusion cycle, part 4. Restore remaining pbars, expel positive ions

① Restore single well potential

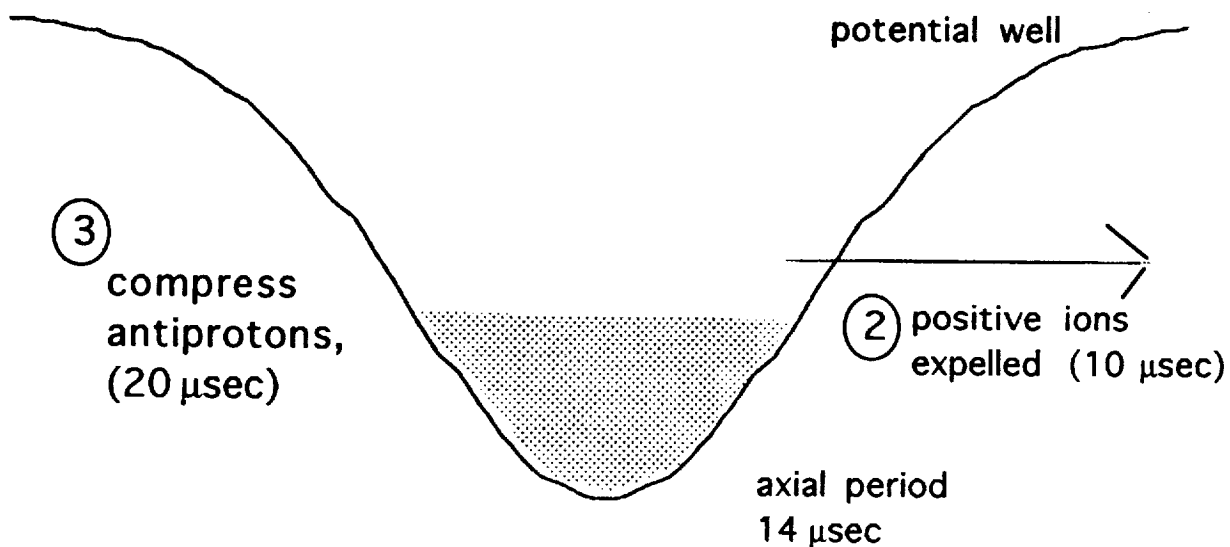

$0.999 \times 10^{11}$  pbars

1 cm

x-y view

0.5 cm



## AIM Four-cycle Aneutronic DHe<sup>3</sup> Fusion Engine

- Role of trapped antiprotons: produce a hot, dense microplasma which ignites fusion reactions.
- Output: 15 kJ per 20 msec cycle => 0.75 MW
- 10<sup>11</sup> antiprotons last for 200 cycles; adiabatic refill in 1 cycle => 99.5% duty factor
- Role: ideal portable space engine

# AIM Four-cycle DT Fusion Engine

- Role of trapped antiprotons: produce a hot, dense microplasma which ignites fusion reactions.
- Output: 80 kJ per 0.6 msec cycle => 133 MW
- $10^{11}$  antiprotons last for 30 cycles; adiabatically refill in 3 cycles => 90% duty factor
- Role: ideal portable, space engine

Table I- AIMStar 50 year Mission to 10,000 A.U.

- 1)  $\Delta V/V_{\text{ex}} = 1.6$  for energy optimization (from rocket eq. this fixes payload to total mass ratio = 0.2);
- 2) 100 kg payload (antiproton storage, reaction traps, micro-sensors and communications systems); propellant mass = 400 kg.

	$\underline{\text{DT}}$ (0.1 yr burn, 49.9 yr coast)	$\underline{\text{DHe}^3}$ (4.4 yr burn, 45.6 yr coast)
$\Delta V$	957 km/sec (0.32% $\circ$ c)	1048 km/sec (0.35% $\circ$ c)
$V_{\text{ex}}$	$5.98 \times 10^5$ m/sec	$6.55 \times 10^5$ m/sec
$I_{\text{sp}}$	61,020 sec	66,837 sec
Power	33 MW ( $\alpha$ 's only)	0.75 MW ( $\alpha$ 's and p's)
$\dot{m}$	$1.27 \times 10^{-4}$ kg/sec	$0.0294 \times 10^{-4}$ kg/sec
$\dot{m}V_{\text{ex}}$	75.9 N	1.9N
$\alpha_{\text{ave}}$	110 kW/kg	2.5 kW/kg
$N_{\text{pbar}}$	26 $\mu\text{g}$	5.7 $\mu\text{g}$

# AIMStar

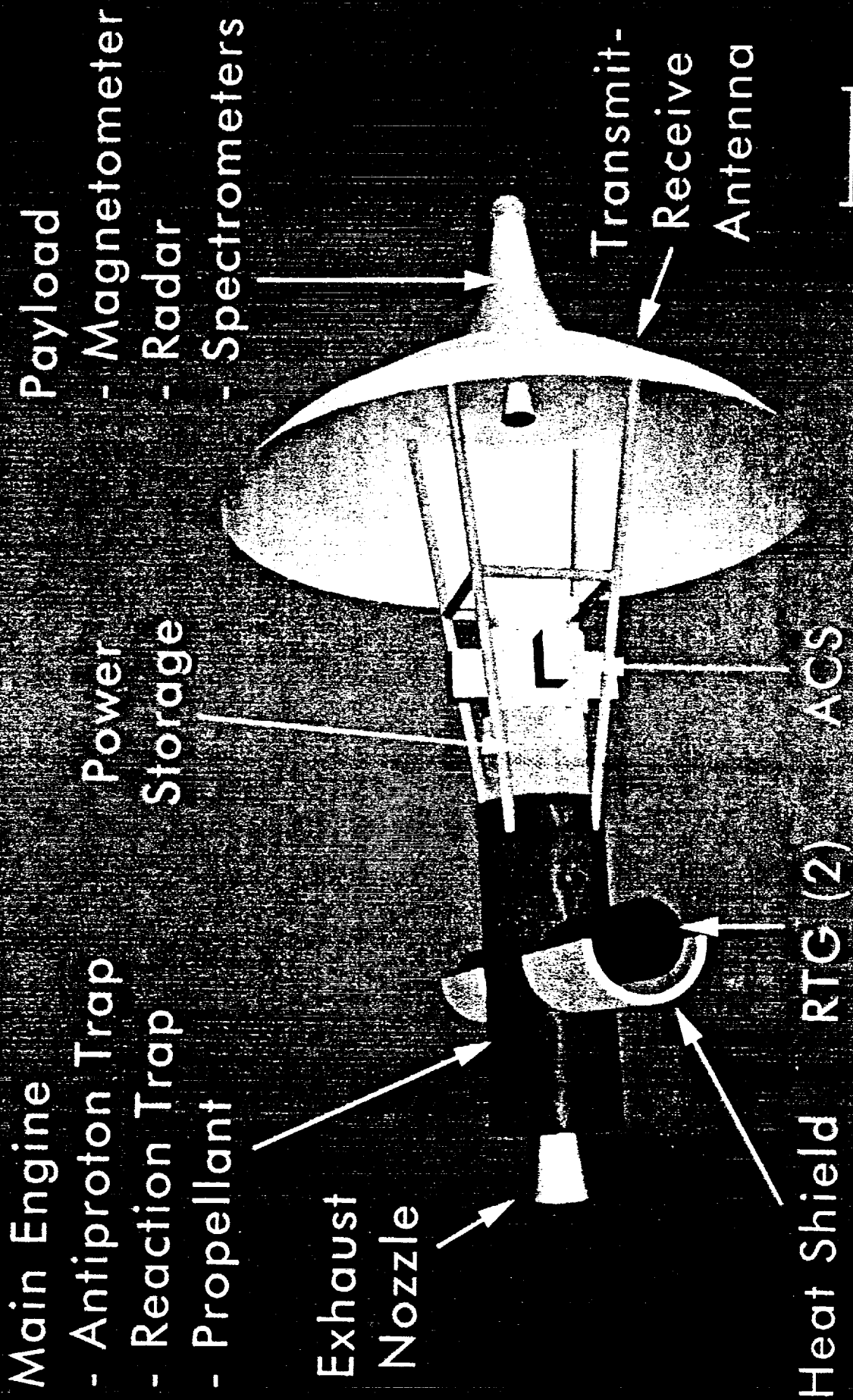

## Preliminary Requirements for AIMStar

<i>Component</i>	<i>Mass (kg)</i>	<i>Power (W)</i>
RTG	55	
Power source (capacitor)	20	
Computer system (C&DH)	10	20
ACS	20	10
Antenna	50	150
Magnetometer*	5	3
Radar*	40	110
Ion-Mass spectrometer*	10	30
IR spectrometer*	40	33
Spacecraft body and nozzle	60	
Hydrogen Tank	25	
Hydrogen prop./antimatter unit	1340	--
<b>TOTAL</b>	<b>1675</b>	<b>356</b>

\*Values for scientific instruments were based from Cassini instruments <<http://www.jpl.nasa.gov/cassini/Science/orbiter.html>>