

NASA/TM—1998-207917



Micro-Coplanar Striplines—New Transmission Media for Microwave Applications

Kavita Goverdhanam
University of Michigan, Ann Arbor, Michigan

Rainee N. Simons
NYMA, Inc., Brook Park, Ohio

Linda P.B. Katehi
University of Michigan, Ann Arbor, Michigan

Prepared for the
1998 International Microwave Symposium
sponsored by the Institute of Electrical and Electronics Engineers
Microwave Theory and Techniques Society
Baltimore, Maryland, June 7–12, 1998

National Aeronautics and
Space Administration

Lewis Research Center

May 1998

Acknowledgments

The authors are grateful to ONR (N00014-95-1-0546) for its support. They would also like to thank Thomas Morthorst of Harris Corp. for discussions on SOG, Allied Signals Inc. for providing the SOG and Thomas Lam of Zeland Software Inc. for providing computed data.

Available from

NASA Center for Aerospace Information
7121 Standard Drive
Hanover, MD 21076
Price Code: A02

National Technical Information Service
5287 Port Royal Road
Springfield, VA 22100
Price Code: A02

MICRO-COPLANAR STRIPLINES - NEW TRANSMISSION MEDIA FOR MICROWAVE APPLICATIONS

Kavita Goverdhanam¹, Rainee N. Simons², Linda P.B. Katehi¹

¹Radiation Laboratory, EECS Department, University of Michigan, Ann Arbor, MI 48109-2122, USA

²NASA Lewis Research Center NYMA Group, Cleveland, OH 44135

Abstract

In this paper a new transmission line for microwave applications, referred to here as the Micro-Coplanar Stripline (MCPS), is introduced. The propagation characteristics, such as, characteristic impedance (Z_o) and effective dielectric constant (ϵ_{eff}) for a range of MCPS geometries have been modeled using the Finite Difference Time Domain (FDTD) Technique and presented here. Also, preliminary experimental results on the performance of an MCPS-Microstrip transition and an MCPS-fed patch antenna are presented. The results indicate several potential applications of the MCPS line in microwave integrated circuit technology.

I Introduction

In recent years, wireless communications for audio, video and data transmission have witnessed tremendous growth. The essential requirements for these wireless systems are low cost for affordability and small size for portability. One approach in addressing low-cost requirements is to combine the available digital silicon processing technology with the high frequency silicon germanium device technology. The size and complexity issues that arise with this integration can be addressed by investigating novel integration techniques which rely on multilayer three dimensional transmission lines constructed using very thin glass or silicon dioxide layers. With appropriate interconnect technology available, customized innovative integrated packages can be realized by micromachining the silicon wafer [1]. These techniques, when realized, have the potential to meet the ever increasing

demand to lower the cost and size of circuit components.

This paper presents a new transmission line, the Micro-Coplanar Stripline (MCPS). Fig. 1 shows the geometry of MCPS. The MCPS is fabricated on a high resistivity silicon (HR Si) wafer and has a very thin spin-on-glass (SOG) as a spacer layer separating two strip conductors. MCPS has several advantages some of which are discussed here: 1) The dimensions of the strip conductors as well as the spacer layer are of the order of a few microns for a 50 Ω transmission line. Thus the transmission line is very compact, resulting in small amount of parasitics when combined with active devices. 2) The strip conductors are on two levels, thus making vertical as well as horizontal integration possible. This can be useful in applications such as mixers using broad-side couplers with tight coupling and wide bandwidth. 3) The spacer layer is very thin, hence making it possible to realize large capacitances in a small area. This feature is very desirable in the design of compact low-pass and bandpass filters. 4) The two strip conductors form a balanced line, making the MCPS an ideal line for feeding integrated antennas, such as, patches, bow-ties and dipoles.

A number of variants of this basic structure, a few of which are shown in Fig. 2, can be used to achieve several advantages. Fig. 2a shows an insulating layer of Silicon dioxide (SiO_2) which can be used to effectively isolate the RF MCPS from the conductive properties of the low resistivity silicon (LR Si) wafer (few Ohms-cm) below. The advantage gained is that CMOS based circuits for signal processing on LR Si can coexist with the RF circuits thereby simplifying integration. Fig. 2b shows a possible configuration us-

ing HR Si wafer (> 3000 ohm-cm). The advantage here is that the HR Si wafer will lower the attenuation and also improve isolation between adjacent circuits. The additional dielectric layer can be used to improve field confinement or for building RF circuits. Fig. 2c shows a geometry where the upper dielectric layer is replaced by an LR Si wafer with an etched groove which can serve as a metal cover or a ground plane for circuits located above. The last configuration, shown in Fig. 2d, is an MCPS which is shielded and suspended inside an enclosure formed by two LR Si wafers with etched grooves. This line is expected to have very low attenuation since the ϵ_{eff} is approximately equal to that of air. Such a transmission line is ideal for constructing feed systems for high gain, high efficiency planar array antennas.

In the following sections, first, a brief description of the fabrication process for the MCPS is presented. Next, the propagation parameters of the MCPS, such as, Z_o and ϵ_{eff} for a range of MCPS geometries is presented. These have been modeled by using the well known FDTD technique [2], [3], [4]. Finally, to demonstrate the applications of this line, preliminary experimental results on an MCPS-Microstrip broadband transition and a feed network for a patch antenna have been presented. The experimental work was performed using a Duroid based MCPS line for the purpose of validating the applicability of the novel transmission line. Fabrication and measurement of SOG-on-Silicon based MCPS lines is currently in progress.

II Fabrication of MCPS:

To begin the fabrication process, the lower strip conductor is fabricated on the substrate (ϵ_{r2}) by a lift-off process [5]. Next, the dielectric spacer layer (ϵ_{r1}) is built-up to the required thickness by multiple spin-coats. Lastly, the upper strip conductor is fabricated using the lift-off process once again. An HR Si (> 3000 ohms-cm) silicon wafer is used as the base substrate and the gold metalization of about $1.0 \mu\text{m}$ thickness is used as the conductor. Accuglass 512 SOG is used as the dielectric spacer layer. The dielectric constant and thickness of the Accuglass used here are 3.1 and $2.5 \mu\text{m}$ respectively. If a higher dielectric constant or thicker layer is required, it is preferable to use other spin coating materials, such as, polyamides.

III Characteristics of MCPS.

A number of MCPS geometries have been characterized using the FDTD technique in order to obtain the characteristic impedance and effective dielectric constant. For these lines, a $400 \mu\text{m}$ thick Silicon substrate ($\epsilon_{r2} = 11.7$) is chosen. The thickness of glass ($\epsilon_{r1} = 3.1$) is $2.5 \mu\text{m}$. Tables 1 and 2 below summarize the Z_o and ϵ_{eff} for SOG-on-Silicon MCPS with line widths (W) $135 \mu\text{m}$ and $94.5 \mu\text{m}$ respectively for overlap (S) ranging from positive ($+27\mu\text{m}$) to negative ($-27\mu\text{m}$). Here, '+' indicates an overlap between the lines and '-' indicates a separation. From the tables, it can be seen that as the overlap distance between the MCP strips increases, the characteristic impedance decreases. This is because with increasing overlap, the coupling (capacitance) between the lines increases, thereby reducing Z_o . Also it is seen that lowering the stripwidth increases Z_o . From these, it is obvious that by varying the parameters involved, a wide range of desired characteristic impedances can be obtained.

While the above line dimensions are useful for feeding patch antennas and transitions, for integrating CMOS with RF circuits, lines with much smaller dimensions are required. It has been found that a line with $W = 10 \mu\text{m}$ and $S = 4 \mu\text{m}$ yields characteristic impedance close to 50Ω . Fabrication of this line on HR Si with a $2.5 \mu\text{m}$ SOG spacer layer is in progress. Although Fig. 1 does not show the probe pads, this line will be characterized using standard on-wafer RF probing equipment.

Table 1: Z_o and ϵ_{eff} of SOG-on-Silicon MCPS: $D_1 = 2.5\mu\text{m}$, $D_2 = 400\mu\text{m}$, $W = 135\mu\text{m}$

Overlap S (μm)	Z_o (Ω)	ϵ_{eff}
+27.0	10.7	3.49
+13.5	14.0	3.67
0.0	22.4	4.02
-13.5	51.2	5.61
-27.0	59.0	5.89

IV Applications of MCPS:

In order to demonstrate the efficacy of this line, a broadband MCPS-Microstrip transition and an MCPS fed Patch antenna have been experimentally charac-

Table 2: Z_o and ϵ_{eff} of SOG-on-Silicon MCPS: $D_1 = 2.5\mu\text{m}$, $D_2 = 400\mu\text{m}$, $W = 94.5\mu\text{m}$

Overlap S (μm)	Z_o (Ω)	ϵ_{eff}
+27.0	11.1	3.40
+13.5	14.6	3.59
0.0	23.9	3.94
-13.5	58.4	5.50
-27.0	66.6	5.79

terized. In doing so, MCPS circuits fabricated on $254\mu\text{m}$ and $127\mu\text{m}$ thick Duroid have been used.

a) **MCPS-Microstrip broadband transition:** The schematic of an MCPS-to-Microstrip back-to-back transition is shown in Fig. 3. In the figure, section A - B corresponds to the microstrip line while section C - D corresponds to the MCPS. The transition consists of a short length of a 50Ω microstrip line of width $254\mu\text{m}$ whose ground plane is abruptly truncated. At this plane, the tapered MCPS strip conductors form a junction with the microstrip line. At the junction, the tapered section of the MCPS conductors form a symmetric parallel plate line. The conductors of the parallel plate are flared out in opposite directions, forming the regular MCPS with $W = 889\mu\text{m}$ while facilitating impedance and mode matching. The relevant parameters of this geometry are as follows:

$D_1 = 254\mu\text{m}$; $\epsilon_{r1} = 10.5$; $\epsilon_{r2} = 1$; $W = 889\mu\text{m}$; $W_1 = 254\mu\text{m}$. Fig. 4 shows the measured S_{11} and S_{21} of this transition. From the figure it can be seen that the insertion loss of the transition is close to 0.7 dB at the center frequency of 7 GHz and has a maximum value of 1.0 dB at 14 GHz. This includes the losses due to the two coaxial launchers of the Wilton test fixture which are of the order of 0.25 dB each. Thus it can be seen that deembedding will further reduce the insertion loss to 0.2 dB at 7 GHz, with the maximum loss being 0.5 dB at 14 GHz. These results indicate that the transition has excellent characteristics over a broad range of operation.

b) **MCPS Feed for a Patch Antenna:** The schematic of an MCPS fed patch antenna which is designed to operate at 19 GHz is shown in Fig. 5. In this circuit, power is coupled to the patch radiator through an

MCPS-to-Microstrip transition. An interesting feature of this feeding network is that it can provide an optimum substrate for a given frequency band of operation by proper choice of the spacer layer thickness D_1 and dielectric constant ϵ_{r1} . The parameters of this circuit are given below:

$D_1 = 127\mu\text{m}$; $\epsilon_{r1} = 10.8$; $D_2 = 762\mu\text{m}$; $\epsilon_{r2} = 10.2$; $a = 3429\mu\text{m}$; $b = 2286\mu\text{m}$. The measured return loss S_{11} of the antenna using an RF wafer probe (10 mil pitch) is shown in Fig. 6. As seen from the figure, the patch antenna resonates at 18.1 GHz while it is designed to resonate at 19.0 GHz. This shift is due to the parasitics added by the MCPS section which have not been deembedded. It can be seen from the figure that the antenna is well matched to the feed. This demonstrates the feasibility of using MCPS as feed lines in the design of antenna arrays for wireless applications.

V Conclusion

A new transmission line, the MCPS, which has the potential to provide extremely compact and low cost circuits with wide design flexibility has been introduced. The propagation characteristics for a wide range of circuit parameters have been presented. Also, the applications of this line has been demonstrated by characterizing an MCPS-Microstrip transition and an MCP-fed Patch antenna.

VI Acknowledgments

The authors are grateful to ONR (N00014-95-1-0546) for its support. They would also like to thank Thomas Morthorst of Harris Corp. for discussions on SOG, Allied Signals Inc. for providing the SOG and Thomas Lam of Zeland Software Inc. for providing computed data.

References

- [1] R. F. Drayton and L. P. B. Katehi, "Development of Self-Packaged High Frequency Circuits Using Micromachining Techniques", *IEEE Trans. Microwave Theory Tech.*, Vol. 43, No. 9, pp. 2073 - 2080, Sept. 1995.
- [2] X. Zhang and K. K. Mei, "Time-Domain Finite Difference Approach to the Calculation of the Frequency-Dependent Characteristics of Microstrip Discontinuities", *IEEE Trans. Microwave Theory Tech.*, Vol. 36, pp. 1775 - 1787, Dec 1988.
- [3] K. Goverdhanam, R. N. Simons and L. P. B. Katehi, "Coplanar Stripline Propagation Characteristics and Band-pass Filter", *IEEE Microwave and Guided Wave Letters*, Vol. 7, No. 8, pp. 214-216, August 1997.

- [4] K. Goverdhanam, R. N. Simons and L. P. B. Katehi, "Coplanar Stripline Components for High-Frequency Applications", IEEE Trans. on Microwave Theory and Techniques, Vol. 45, No. 10, pp. 1725-1729, October 1997.
- [5] R. Williams, "Modern GaAs Processing Methods", 2nd ed., Ch. 6, pp. 116, Artech House Inc., MA: Dedham, 1990.

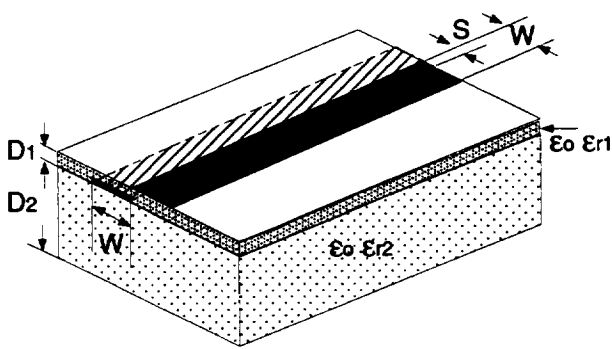

Figure 1: Geometry of MCPS line

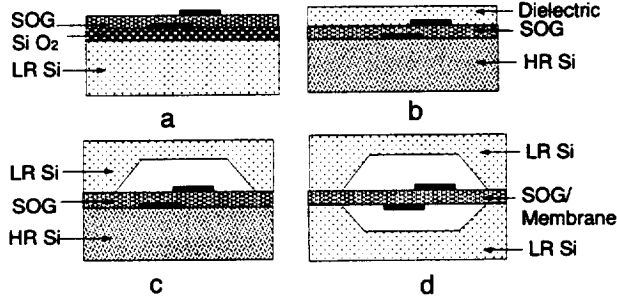

Figure 2: MCPS Variants.

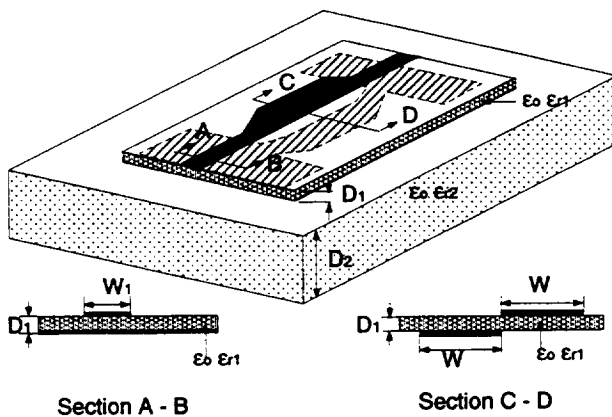

Figure 3: MCPS-Microstrip Transition.

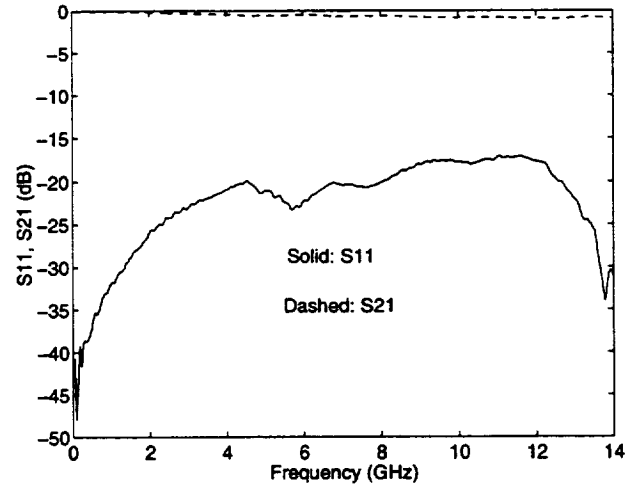

Figure 4: S_{11} and S_{21} of MCPS-Microstrip Transition.

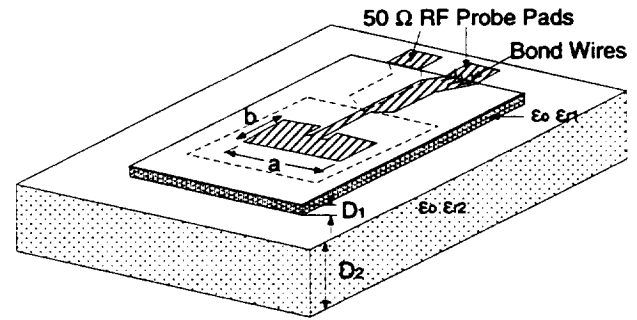

Figure 5: Patch Antenna with MCPS Feed.

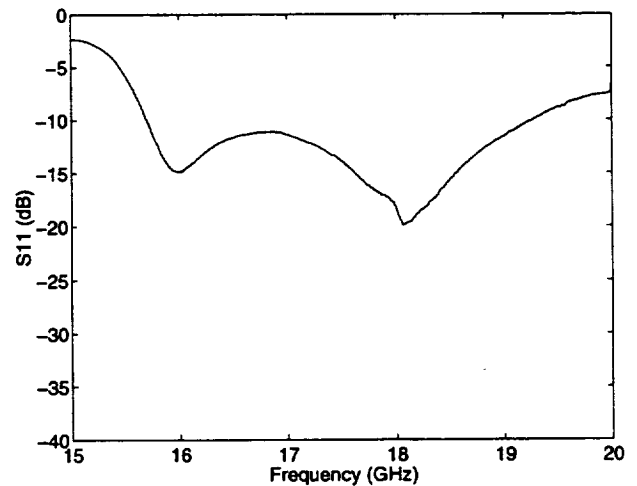

Figure 6: Return loss on MCPS-fed Patch Antenna.

REPORT DOCUMENTATION PAGE

Form Approved
OMB No. 0704-0188

Public reporting burden for this collection of information is estimated to average 1 hour per response, including the time for reviewing instructions, searching existing data sources, gathering and maintaining the data needed, and completing and reviewing the collection of information. Send comments regarding this burden estimate or any other aspect of this collection of information, including suggestions for reducing this burden, to Washington Headquarters Services, Directorate for Information Operations and Reports, 1215 Jefferson Davis Highway, Suite 1204, Arlington, VA 22202-4302, and to the Office of Management and Budget, Paperwork Reduction Project (0704-0188), Washington, DC 20503.

1. AGENCY USE ONLY (Leave blank)		2. REPORT DATE May 1998	3. REPORT TYPE AND DATES COVERED Technical Memorandum	
4. TITLE AND SUBTITLE Micro-Coplanar Striplines—New Transmission Media for Microwave Applications			5. FUNDING NUMBERS WU-632-50-5B-00	
6. AUTHOR(S) Kavita Goverdhanam, Rainee N. Simons, and Linda P.B. Katehi				
7. PERFORMING ORGANIZATION NAME(S) AND ADDRESS(ES) National Aeronautics and Space Administration Lewis Research Center Cleveland, Ohio 44135-3191			8. PERFORMING ORGANIZATION REPORT NUMBER E-11192	
9. SPONSORING/MONITORING AGENCY NAME(S) AND ADDRESS(ES) National Aeronautics and Space Administration Washington, DC 20546-0001			10. SPONSORING/MONITORING AGENCY REPORT NUMBER NASA TM-1998-207917	
11. SUPPLEMENTARY NOTES Prepared for the 1998 International Microwave Symposium sponsored by the Institute of Electrical and Electronics Engineers Microwave Theory and Techniques Society, Baltimore, Maryland, June 7-12, 1998. Kavita Goverdhanam and Linda P.B. Katehi, Radiation Laboratory, EECS Department, University of Michigan, Ann Arbor, Michigan 48109-2122; Rainee N. Simons, NYMA, Inc., 2001 Aerospace Parkway, Brook Park, Ohio 44142 (work funded by NASA Contract NAS3-98022). Responsible person, Rainee N. Simons, organization code 5640, (216) 433-3462.				
12a. DISTRIBUTION/AVAILABILITY STATEMENT Unclassified - Unlimited Subject Category: 33 This publication is available from the NASA Center for AeroSpace Information, (301) 621-0390.			12b. DISTRIBUTION CODE Nonstandard	
13. ABSTRACT (Maximum 200 words) In this paper a new transmission line for microwave applications, referred to here as the Micro-Coplanar Stripline (MCPS), is introduced. The propagation characteristics, such as, characteristic impedance (Z_0) and effective dielectric constant (ϵ_{eff}) for a range of MCPS geometries have been modeled using the Finite Difference Time Domain (FDTD) Technique and presented here. Also, preliminary experimental results on the performance of an MCP-Microstrip transition and an MCPS-fed patch antenna are presented. The results indicate several potential applications of the MCPS line in microwave integrated circuit technology.				
14. SUBJECT TERMS			15. NUMBER OF PAGES 00	
			16. PRICE CODE A00	
17. SECURITY CLASSIFICATION OF REPORT Unclassified	18. SECURITY CLASSIFICATION OF THIS PAGE Unclassified	19. SECURITY CLASSIFICATION OF ABSTRACT Unclassified	20. LIMITATION OF ABSTRACT	